



**Under Fryer Filter (UFF) and
Single Under Fryer Filter (SUFF)**

SUFF/UFF Filtration Systems
 Installation & Operation Manual

PARTS LIST
INCLUDED



Frymaster/Dean, a member of the Commercial Food Equipment Service Association, recommends using CFESA Certified Technicians.

PRINTED IN THE USA

24-Hour Service Hotline
1-800-551-8633

OCTOBER 2011
*** 8195809A ***

Please read all sections of this manual and retain for future reference.

Installation, maintenance, and repairs should be performed by your Frymaster/Dean Factory Authorized Servicer.

 WARNING

Safe and satisfactory operation of your equipment depends on its proper installation. Installation MUST conform to local codes, or in the absence of local codes, with the latest edition of the National Electric Code, N.F.P.A. 70.

 WARNING

ELECTRICAL GROUNDING INSTRUCTIONS

This filter is equipped with a three-prong, grounded plug for your protection against shock hazard and should be plugged directly into a properly grounded, three-hole receptacle. Do not cut off, remove or otherwise bypass the grounding prong on this plug.

If it is necessary to use an extension cord, it MUST be a three-conductor, grounded cord of 16 gauge or greater.

 DANGER

Do not filter more than one fry tank at a time.

Hot fluid – Do not fill above a point 1½ inches below the OIL CONTAINER RIM.

 WARNING

This filter unit is not suitable for outdoor use. When operating this unit, it MUST be placed on a horizontal surface.

 WARNING

This filter unit is not suitable for installation in an area where a water jet can be used, and this appliance MUST NOT be cleaned with a water jet.

NOTICE:

If this filter unit is cleaned with water, disconnect the unit from power source before cleaning and thoroughly dry the filter unit before reconnecting to electrical power source.

 **DANGER**

The crumb tray (if equipped) in portable filter systems must be emptied into a fireproof container at the end of frying operations each day. Some food particles can spontaneously combust if left soaking in certain shortening material.

NOTICE:

Drawings and photos used in this manual are intended to illustrate operational, cleaning and technical procedures and may not conform to on-site management operational procedures.

NOTICE

IF, DURING THE WARRANTY PERIOD, THE CUSTOMER USES A PART FOR THIS MANITOWOC FOOD SERVICE EQUIPMENT OTHER THAN AN UNMODIFIED NEW OR RECYCLED PART PURCHASED DIRECTLY FROM FRYMASTER/DEAN, OR ANY OF ITS AUTHORIZED SERVICERS, AND/OR THE PART BEING USED IS MODIFIED FROM ITS ORIGINAL CONFIGURATION, THIS WARRANTY WILL BE VOID. FURTHER, FRYMASTER/DEAN AND ITS AFFILIATES WILL NOT BE LIABLE FOR ANY CLAIMS, DAMAGES OR EXPENSES INCURRED BY THE CUSTOMER WHICH ARISE DIRECTLY OR INDIRECTLY, IN WHOLE OR IN PART, DUE TO THE INSTALLATION OF ANY MODIFIED PART AND/OR PART RECEIVED FROM AN UNAUTHORIZED SERVICER.



TABLE OF CONTENTS



SUFF/UFF FILTRATION SYSTEMS INSTALLATION & OPERATION MANUAL

Chapter 1.	INTRODUCTION.....	1-1
1.1	Ordering Parts.....	1-1
1.2	Service Information.....	1-1
1.3	After Purchase.....	1-2
1.4	Safety Information.....	1-2
Chapter 2	IMPORTANT INFORMATION.....	2-1
2.1	General.....	2-1
2.2	Rating Plate.....	2-1
2.3	Pre-installation.....	2-2
2.4	Unpacking the Filter System.....	2-2
Chapter 3	INSTALLATION AND OPERATION INSTRUCTIONS.....	3-1
3.1	General.....	3-1
3.2	Filter Prep.....	3-2
3.2.1	Filter Unit Identification.....	3-2
3.2.2	Assembling the Filter.....	3-6
3.2.3	Installing the Filter.....	3-12
3.3	Daily Filtration Operation.....	3-13
3.3.1	General Overview.....	3-13
3.3.2	Filtering Tools.....	3-13
3.4	Operating the Filter.....	3-14
3.4.1	Pan Preparation and Operation.....	3-14
3.4.2	Filter Operation.....	3-16
3.4.3	Hose and Wand Operation.....	3-19
Chapter 4	CLEANING AND MAINTENANCE.....	4-1
4.1	General.....	4-1
4.2	Each Filter Use.....	4-1
4.3	Daily (Close of Business).....	4-3
4.4	Weekly.....	4-3
Chapter 5	TROUBLESHOOTING.....	5-1
Chapter 6	PARTS LIST.....	6-1
6.1	SUFF 80 BID80 Series.....	6-1
6.2	SUFF 80 Domestic (Early Style).....	6-2
6.3	SUFF 80 Domestic (Current).....	6-3
6.4	SUFF 60 (Current Production-Domestic and 18UE/BIH1721).....	6-4
6.5	SUUF 50 (Early Style).....	6-5
6.6	SUFF 50 (Current Style).....	6-6
6.7	Super Cascade 75 (Early Style).....	6-7
6.8	UFF Components D50 and D60 Series Fryers (Current Production).....	6-9
6.9	UFF Components D50 and D60 Series Fryers (Previous Production).....	6-10
6.10	KFC 218G/E UFF (2002).....	6-12
6.11	UFF 80 (Current Style).....	6-14
6.12	UFF 85 Filter-leaf Equipped Flatbottom (2424).....	6-15
6.13	Caster and Accessories.....	6-17

SUFF/UFF FILTRATION SYSTEMS

CHAPTER 1: INTRODUCTION

1.1 Ordering Parts

Customers may order parts directly from their local Factory Authorized Servicer (FAS). See the numbers listed in section 1.2 to find your nearest FAS.

To speed up your order, the following information is required:

Model Number		Type	
Serial Number			
Optional Features			
Item Part Number		Quantity Needed	

1.2 Service Information

Call the 1-800-551-8633 or (318) 865-1711 Service Hotline number for the location of your nearest Factory Authorized Servicer. Always give the model and serial numbers of your filter unit.

To assist you more efficiently, the following information will be needed:

Model Number		Type	
Serial Number			
Optional Features			
Nature of Problem:			

Additional information (i.e. oil temperature at filter time, time of day and other pertinent information) may be helpful in solving your service problem.

**SUFF/UFF FILTRATION SYSTEMS
CHAPTER 1: INTRODUCTION**

1.3 After Purchase

In order to improve service, have the following chart filled in by the Frymaster/Dean Authorized Service r who installed this equipment.

Authorized Servicer/FAS	
Address	
Telephone/Fax	
Model Number	
Serial Number	

1.4 Safety Information

Before attempting to operate your unit, read the instructions in this manual thoroughly.

Throughout this manual, you will find notations enclosed in double-bordered boxes similar to the ones below.

CAUTION boxes contain information about actions or conditions that *may cause or result in a malfunction of your system.*



WARNING boxes contain information about actions or conditions that *may cause or result in damage to your system,* and may cause your system to malfunction.



DANGER boxes contain information about actions or conditions that *may cause or result in injury to personnel,* and may cause damage to your system and/or cause your system to malfunction.



SUFF/UFF FILTRATION SYSTEMS

CHAPTER 2: IMPORTANT INFORMATION

2.1 General

Multi-battered frying systems can come equipped with the Under Fryer Filter (UFF) system. Single fryers can come equipped with the Single Under Fryer Filter (SUFF) system. Filter design varies according to the model of the fryer/frying system.

Oil or shortening is drained from the fryer into the filter pan, then pumped back into the frypot by means of oil-return plumbing built into the fryer.

Filtering is accomplished with one sheet of replaceable filter paper and filter powder, or by means of a filter-leaf assembly (see photos below).



Applying filter powder to filter paper.

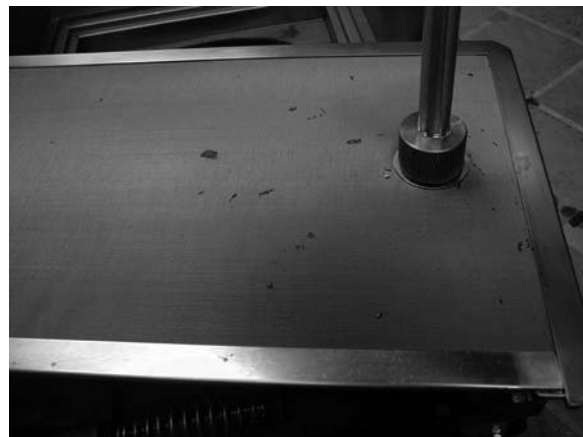

Optional filter-leaf used in place of filter paper.

CAUTION

The on-site supervisor is responsible for ensuring that operators are made aware of the inherent dangers of operating a hot oil filter system, particularly the aspects of oil filtration, and draining/cleaning procedures.

2.2 Rating Plate

Information on the rating plate includes model and serial numbers, as well as electrical requirements. Have the rating plate information handy when communicating with the factory about a unit or requesting special parts or information. Without this information, proper identification of the unit cannot be confirmed.

SUFF/UFF FILTRATION SYSTEMS
CHAPTER 2: IMPORTANT INFORMATION

2.3 Pre-installation

NOTE: Failure to use qualified service personnel will void the Dean warranty.

- A. Standards: Usage of this filter unit must be in accordance with all applicable state and local codes.
- B. Electrical Connections: SUFF/UFF filter systems require connection to a 120V, 60-cycle, 15-amp power supply, or a 220V, 50-cycle, 7-amp power supply. Units are equipped with a grounded male receptacle for use with a 3-wire, 16 AWG power-cord set. If an extension cord is required, it must be a three-conductor, grounded power cord of at least 16 gauge.
- C. Safety Features: A 5-amp (230V) or a 7-amp (115V) circuit breaker switches the power OFF if an overload occurs. In addition, a thermal-overload circuit breaker is built into the filter motor. If an overload occurs, allow the motor to cool for 45 minutes, then press the reset button to reset the thermal-overload circuit.

NOTE: If the circuit breaker is triggered, depress the reset button to activate the circuit after the failure has been detected and repaired.

2.4 Unpacking the Filter System

Ensure the container is upright. Unpack the filter carefully and remove all accessories (if included) from the carton. Do not discard or misplace parts and/or accessories; they will be needed. Any accessories or starter kits included with the unit will be packaged inside the filter tank strapped to the shipping frame.

After unpacking, immediately check the equipment for visible signs of shipping damage. If such damage has occurred, contact the carrier and file the appropriate freight claims. Do not contact the factory, as the responsibility of shipping damage is between the carrier and dealer or end user.

If your equipment arrives damaged:

- a. File claim for damages immediately – Regardless of extent of damage.
- b. Visible loss or damage – Be sure this is noted on the freight bill or express receipt and is signed by the person making the delivery.
- c. Concealed loss or damage – If damage is unnoticed until equipment is unpacked, notify freight company or carrier immediately, and file a concealed damage claim. This should be done within 15 days of date of delivery. Retain the shipping container for inspection.

NOTE: Dean does not assume responsibility for damage or loss incurred in transit.

SUFF/UFF FILTRATION SYSTEMS

CHAPTER 3: INSTALLATION AND OPERATION

WARNING

Drawings and photos used in this manual are intended to illustrate operational, cleaning and technical procedures and may not conform to on-site management operational procedures.

3.1 General

Most SUFF/UFF systems use filter paper as the filter medium. Some filter systems can be special ordered with a filter-leaf assembly, which eliminates the need for filter paper. Both types require the use of filter powder to enhance the filtration process. Photos used in the procedural illustrations may or may not resemble the filter unit that came with the frying system. The following procedures apply to all fryers equipped with SUFF/UFF filter systems. Filter system design depends on the frying system configuration (single or multi-battered systems- see photos below).

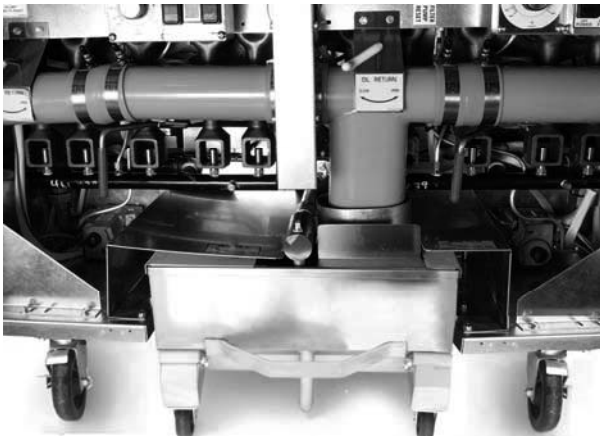

Typical Under Fryer Filter (UFF) installed in a multi-battered frying system.

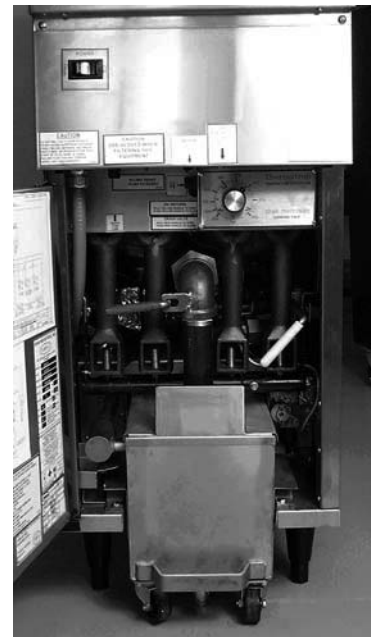

Typical Single Under Fryer Filter (SUFF) installed in a single fryer.

SUFF/UFF FILTRATION SYSTEMS

CHAPTER 3: INSTALLATION AND OPERATION

3.2 Filter Preparation

On initial installation and before each use, clean the filter:

- a. remove all loose parts from the filter,
- b. wash the filter pan and all accessories in hot, soapy water,
- c. and dry thoroughly.

3.2.1 Filter Unit Identification

Current Production

SUFF/UFF filtration systems use filter paper or a filter-leaf to remove impurities. Filter paper is held in place by a hold-down ring.

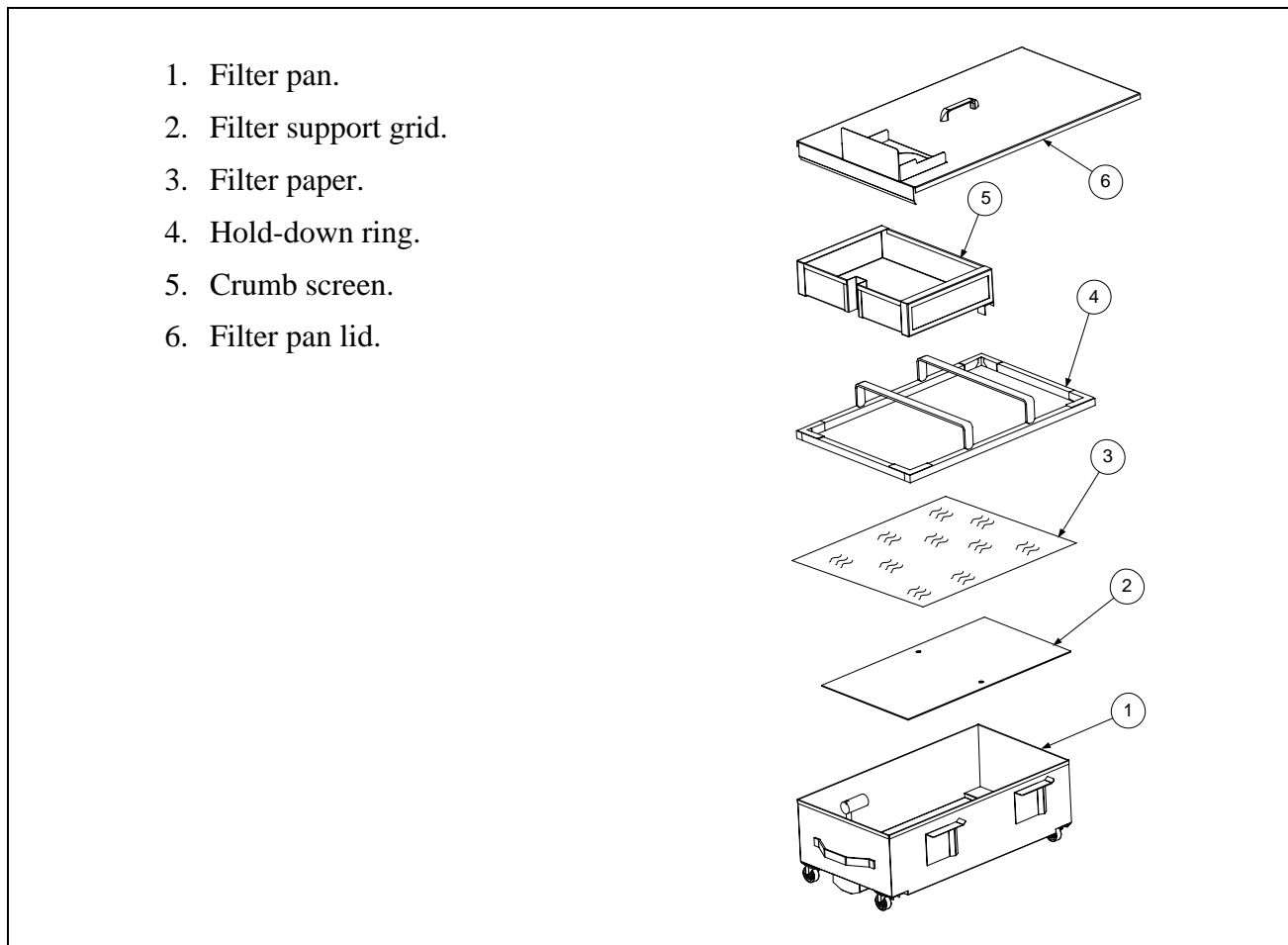

Latchless or weighted hold-down ring filter assembly (current production).

SUFF/UFF FILTRATION SYSTEMS

CHAPTER 3: INSTALLATION AND OPERATION

Previous Production

Previous production filter units differed slightly from current production units. There were two types of hold-down rings: the latchless or weighted hold-down ring (similar to current production) and the latching hold-down ring.

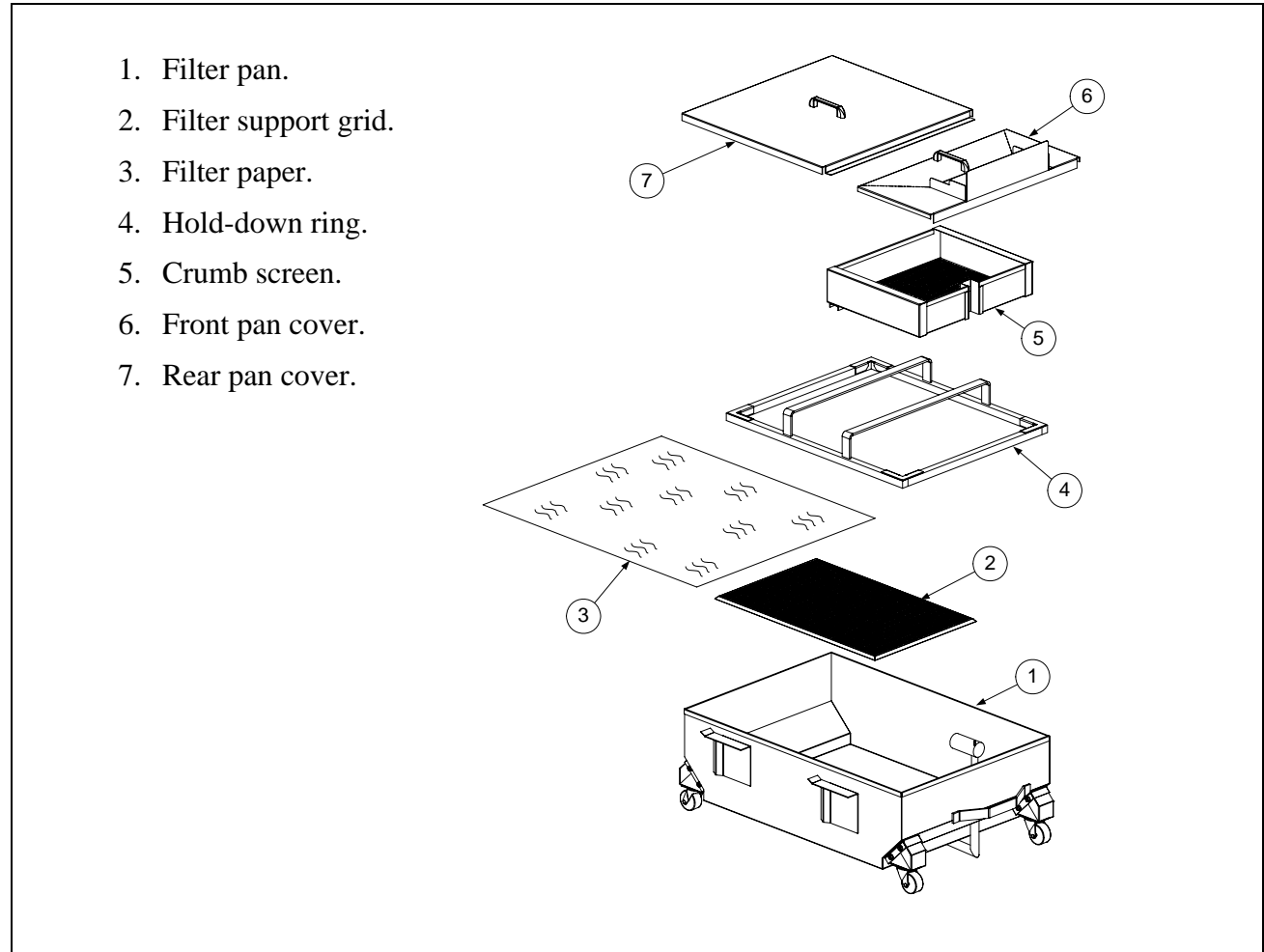

Latchless or weighted hold-down ring filter assembly (previous production).

SUFF/UFF FILTRATION SYSTEMS CHAPTER 3: INSTALLATION AND OPERATION

3.2.1 Filter Unit Identification (cont.)

A latching hold-down ring filter assembly is shown below:

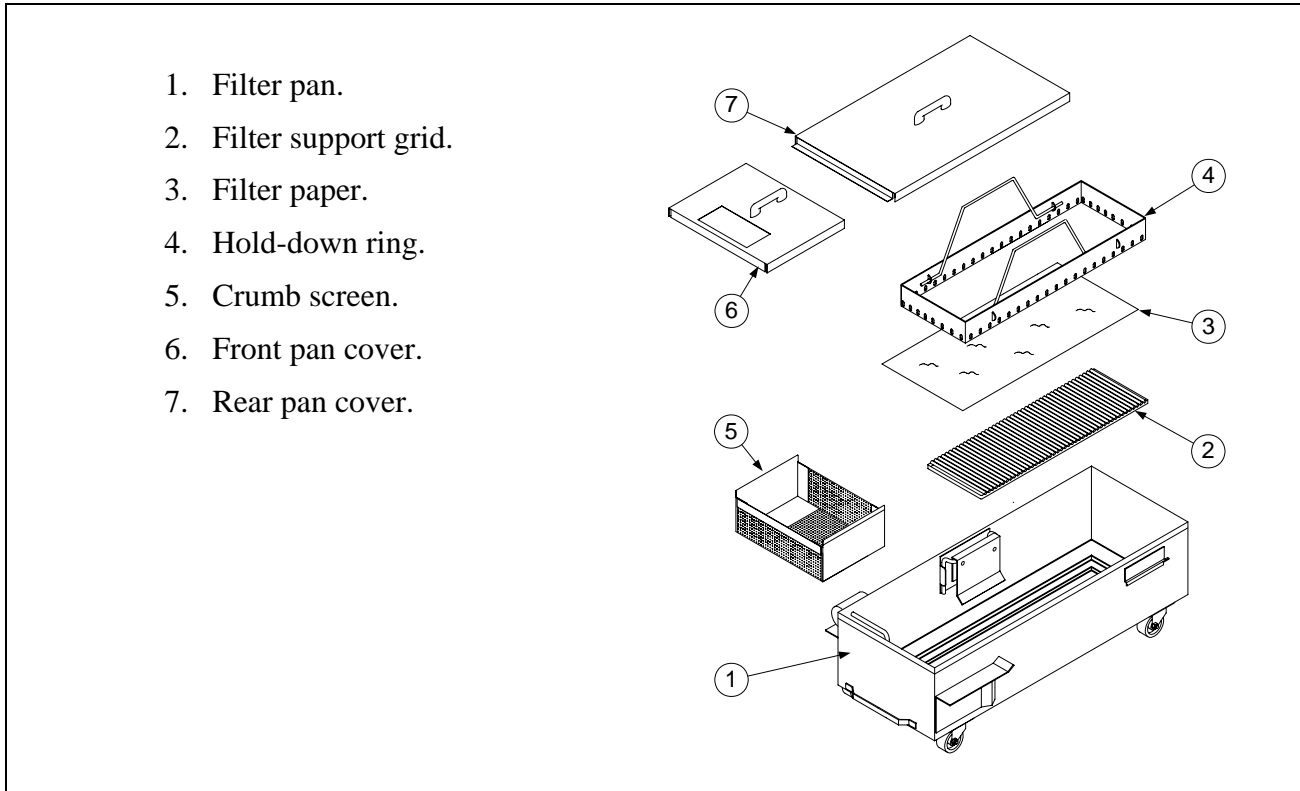

Latching hold-down ring filter assembly (previous production).

SUFF/UFF FILTRATION SYSTEMS

CHAPTER 3: INSTALLATION AND OPERATION

3.2.1 Filter Unit Identification (cont.)

SUFF/UFF systems incorporating a filter-leaf assembly use a fine mesh screen to filter impurities and debris from the oil. The oil is pumped through the screen and then returned to the frypot. The advantages of the filter-leaf include unlimited re-use and the elimination of paper cost.

Filter pans with filter-leaf assemblies are assembled as illustrated below:

1. Filter pan with caddy assembly.
2. Compression cap and riser intake assembly.
3. Filter-leaf assembly.
4. Crumb screen.
5. Filter pan cover.

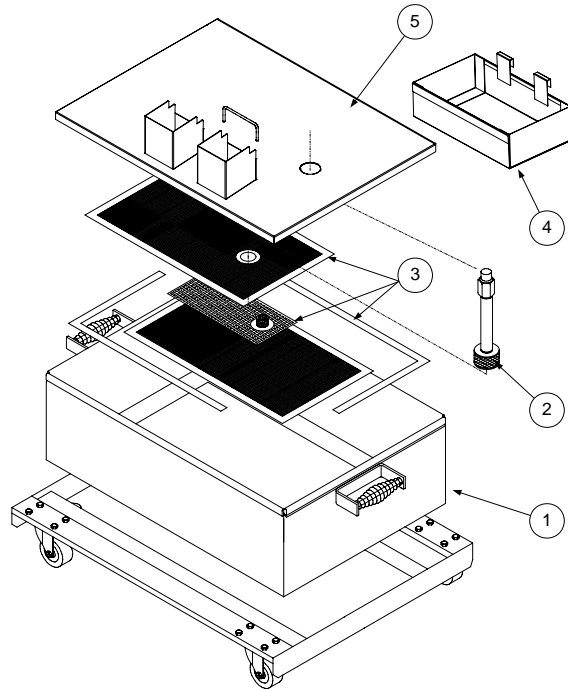

Filter-leaf assembly.

SUFF/UFF FILTRATION SYSTEMS

CHAPTER 3: INSTALLATION AND OPERATION

3.2.2 Assembling the Filter

Assembling Filter Units with Latchless Hold-down Rings

1. Place the support grid in the bottom of filter pan.

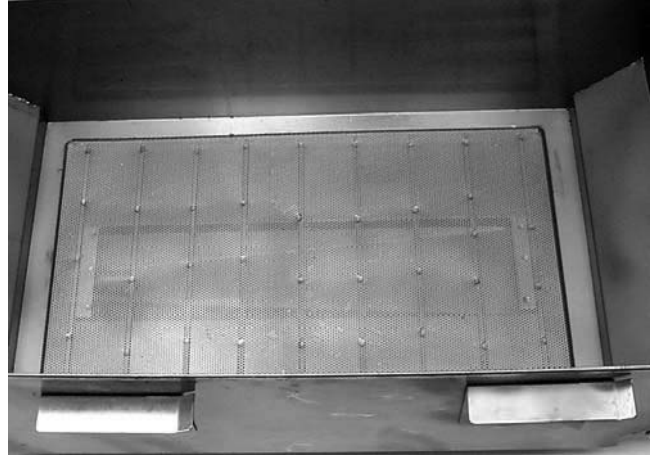

Support grid properly placed in filter pan.

2. Put one filter paper sheet on top of the support grid. Be sure the paper covers the filter pan bottom and laps two inches onto the pan wall.

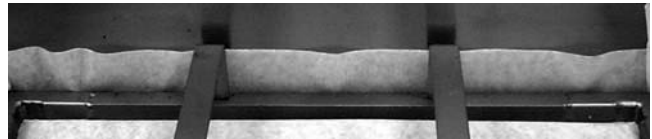

Ensure filter paper overlaps two inches on all sides and is evenly distributed under the hold-down ring.

3. Position the hold-down ring on top of the filter paper. Ensure the hold-down ring seals around the support grid. This prevents air from getting into the system.



Hold-down ring positioned correctly over filter paper in filter pan.

SUFF/UFF FILTRATION SYSTEMS

CHAPTER 3: INSTALLATION AND OPERATION

3.2.2 Assembling the Filter (cont.)

4. Sprinkle 8 ounces of filter powder on the filter sheet. Ensure the powder covers the filter paper evenly.



Sprinkle the proper amount of filter powder evenly over the paper.

5. Place the crumb screen in the filter pan. Allow the crumb screen to rest on the top edges of the hold-down ring.



Crumb screen properly placed.

6. Place filter pan cover onto the filter pan assembly. Ensure the cover is correctly positioned over the slip fitting.

NOTE: Previous production units had two covers (front and back). If this is the case, place both covers on the filter pan and ensure that the front cover is correctly positioned over the slip fitting.



Fully assembled pan with proper placement of lid over slip fitting (slip-fitting orientation may vary according to fryer system).

SUFF/UFF FILTRATION SYSTEMS

CHAPTER 3: INSTALLATION AND OPERATION

3.2.2 Assembling the Filter (cont.)

Assembling Filter Units with Latching Hold-down Rings

1. Place the filter screen in the pan. Ensure it is properly seated in the bottom recess.



Placing filter screen (pan grid) in filter pan.

2. Place one sheet of filter paper over the filter screen.



3. Install the hold-down ring over the filter paper. Ensure the hold-down ring is properly seated in the bottom recess.

Note: When placing the hold-down ring over the filter paper, use care not to tear the filter paper when locking the ring down. Sediment can get into the filter system through tears in the filter paper.

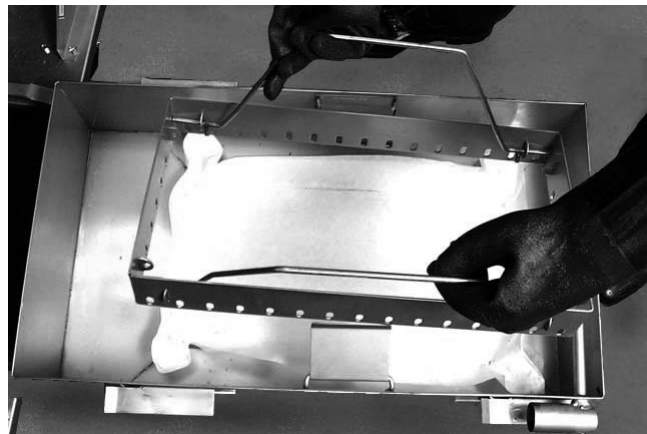

Installing hold-down ring over filter paper.

SUFF/UFF FILTRATION SYSTEMS

CHAPTER 3: INSTALLATION AND OPERATION

3.2.2 Assembling the Filter (cont.)

4. Latch the hold-down ring to lock the filter paper in place. Simultaneously lock both clamps in place by pressing down and in on each clamp (see photo at right).



Locking hold-down ring in place.

5. Sprinkle 1-cup (8 ounces/227 grams) evenly over the paper.



Applying filter powder to filter paper.

6. Install crumb screen after applying the proper amount of filter powder.

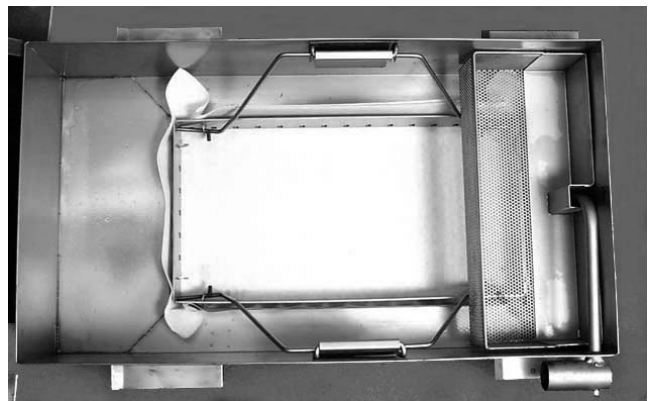

Crumb screen properly installed in filter pan.

SUFF/UFF FILTRATION SYSTEMS

CHAPTER 3: INSTALLATION AND OPERATION

3.2.2 Assembling the Filter (cont.)

7. Place filter pan covers (2) onto the filter pan assembly. Ensure the front cover is correctly positioned over the slip fitting (if applicable). Slip fitting orientation may vary according to fryer system.



Pan covers properly placed on filter pan.

Assembling Filter Units with the Filter-Leaf

1. Remove the filter pan lid.



Filter pan with cover removed.

2. Place the filter-leaf assembly in the bottom of the filter pan.

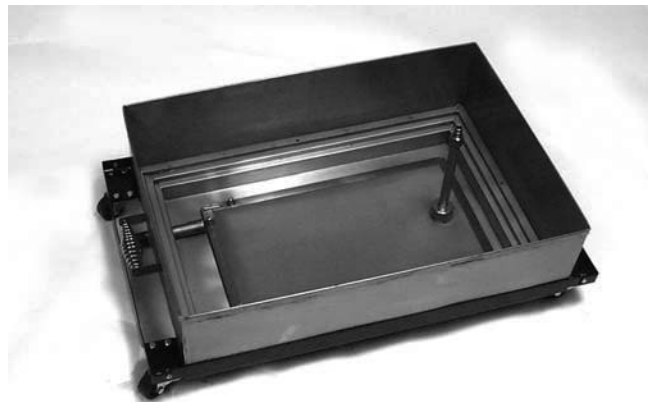

Filter leaf properly positioned in filter pan.

SUFF/UFF FILTRATION SYSTEMS
CHAPTER 3: INSTALLATION AND OPERATION

3.2.2 Assembling the Filter (cont.)

3. Apply the proper amount of filter powder to the filter-leaf, using the manufacturer's recommended amount.

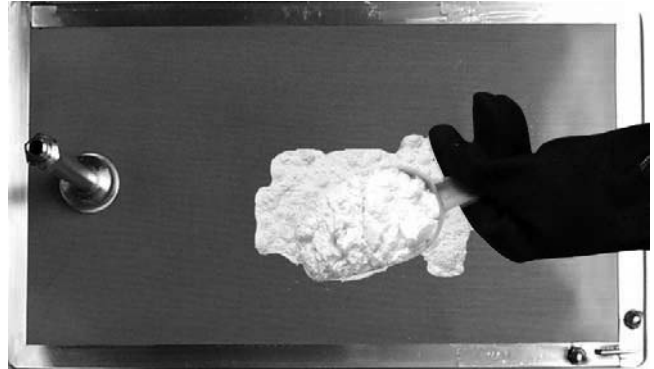

Applying filter powder to filter-leaf.

4. Place the crumb tray in pan after filter powder application.



Crumb screen properly placed in filter pan.

5. Replace the pan lid. Ensure the pickup tube is properly positioned in pan lid opening.



Pickup tube properly positioned in pan lid access hole.

SUFF/UFF FILTRATION SYSTEMS

CHAPTER 3: INSTALLATION AND OPERATION

3.2.3 Installing the Filter

1. Slide the filter inside the fryer cabinet. For latchless and latching hold-down ring equipped filters, ensure the male-female slip-fitting coupling is fully engaged. Ensure the filter pan opening is directly under the center dump tube (current) or angled drain tubes (previous) to avoid splashing hot oil.

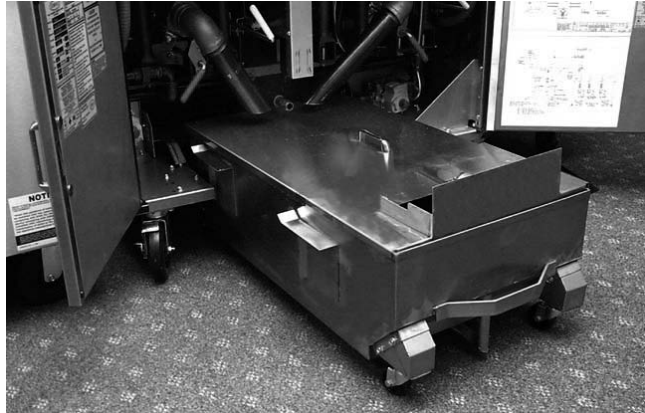

The filter pan slides under the fryer (above), connecting with a slip fitting (right). Slip fitting location will vary (above or to the side of the filter pan), according to fryer system.



2. On filter-leaf equipped filters, ensure the filter system hose disconnect is properly attached to the filter-leaf disconnect. Ensure the filter pan openings are properly positioned under the drain tubes to avoid splashing hot oil.

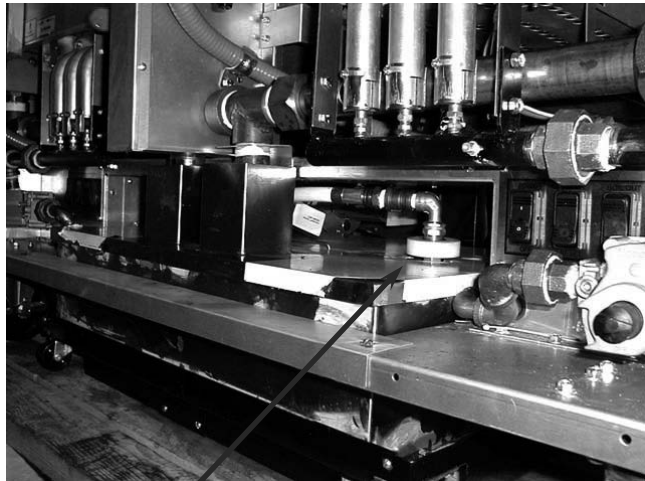

Filter-leaf disconnect properly attached to filter system hose disconnect.

SUFF/UFF FILTRATION SYSTEMS
CHAPTER 3: INSTALLATION AND OPERATION

3.3 Daily Filtration Operation

⚠ WARNING

Use caution and wear proper protective clothing. The oil to be filtered is at or near 350°F (177°C). Ensure all hoses are connected properly and drain handles are in their proper position prior to operating any switches or valves. Failure to do this can result in severe burns.

⚠ WARNING

Drawings and photos used in this manual are intended to illustrate operational, cleaning and technical procedures and may not conform to on-site management operational procedures.

3.3.1 General Overview

Only filter oil at operating temperature (~350°F/~177°C). When filtering begins, the filter motor is engaged and oil is drawn through filter paper or a filter-leaf assembly and pumped back into the frypot. The frypot's drain remains open during the filtering process. Allow the oil to cycle through the filter process for approximately 5 minutes. At the end of 5 minutes, close the drain valve and allow the pump to fill the frypot to the top OIL LEVEL line. Leave the pump running for 10-15 seconds after bubbles appear in the frypot to ensure all oil is pumped from the drain pan and the lines.

3.3.2 Filtering Tools

Assemble tools to be used for filtering. These are supplied with the filter starter kit included with the fryer/filter system:

- Frypot/Filter Brush - used to clean frypot and filter pan sides and bottom, heating elements, and to dislodge sediment during filtration or oil change.
- Clean-out Rod (design may vary) - used to dislodge heavy debris in the drain tube (when needed).
- Filter Powder.
- Filter Paper (not used in filter-leaf equipped filter systems).

The following tools are not required, but are recommended to make the filtering task easier.

- Measuring Cup - used to measure filter powder.
- Stainless Steel Crumb Scoop - for removing large debris from oil prior to filtering.

Note: Always wear oil-resistant, insulated gloves and/or protective gear when working with hot oil.

SUFF/UFF FILTRATION SYSTEMS
CHAPTER 3: INSTALLATION AND OPERATION

3.4 Operating the Filter

3.4.1 Pan Preparation and Operation

See Section 3.2.1, *Assembling the Filter*, and Section 3.2.2, *Installing the Filter*, for the appropriate filter preparation procedure.

⚠ CAUTION

NEVER operate the filter unit unless cooking oil is at operating temperature (~350°F/ ~177°C).

1. Ensure the filter pan assembly is prepared as described in Section 3.2.1, *Assembling the Filter*, and turn fryer off.

2. Remove fry baskets from frypot and skim any large debris from the oil. Use extreme caution, as oil is at or near operating temperature (~350°F/~177°C).



Prior to filtering, skim any large debris from oil in frypot.

3. Remove the support grid from the frypot using the clean-out rod. Stir the oil with the frypot/filter brush to suspend debris prior to draining.



Removing support grid from fry vessel prior to filtering.

SUFF/UFF FILTRATION SYSTEMS
CHAPTER 3: INSTALLATION AND OPERATION

3.4.1 Pan Preparation and Operation (cont.)

4. After ensuring the filter pan is correctly positioned under the drain tubes, move the red handle into the open position to drain the frypot into the filter pan. Drain **ONLY** one frypot at a time. The filter pan is designed to hold the contents of one frypot only.

Note: A drain-flush option is available on some 3-battery and larger frying systems, according to model. The drain-flush prevents sediment from clogging the drain line in multi-battered systems. After draining the third (or fourth) frypot, close the drain valve (red handle) to all frypots. Ensure all other valves (red and yellow handles) are closed. Pull the blue handle to open the flush valve. After the drain line is clear of sediment (approximately 2 minutes), push the blue handle to close flush valve. Re-open the drain valve (red handle) on the drained frypot and continue with Step 5.

5. After all oil has drained from the frypot into the filter pan, pull the yellow handle to open the oil return lines and activate the filter pump.



Move the red drain valve handle into the open position.

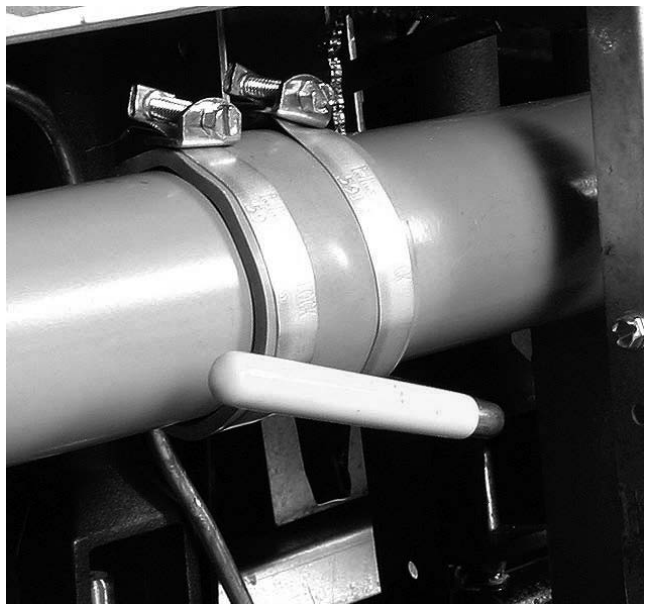

Pull the yellow handle to open the oil return valve and activate the filter pump.

SUFF/UFF FILTRATION SYSTEMS

CHAPTER 3: INSTALLATION AND OPERATION

3.4.2 Filter Operation

- Oil will begin to pump from the filter pan into the frypot. If the frypot tubes, sides and bottom have sediment deposits, clean the frypot with the cleaning brush included with the fryer. Clean beneath and under the burner tubes, using care not to disturb the probes (arrow).

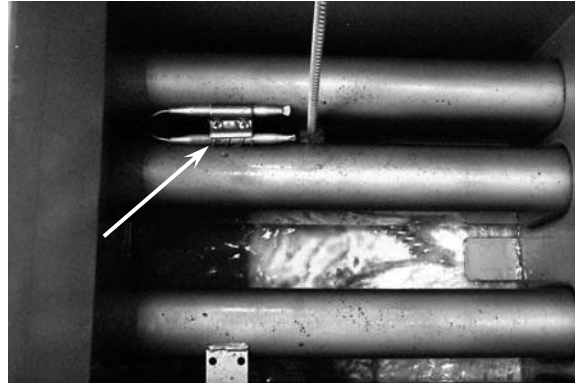

Clean all sediment and suspended particles from the burner tubes and frypot as the oil begins to circulate. Use care not to disturb the probes (arrow) on the burner tube.

- Allow the oil to circulate for approximately 5 minutes (process known as "polishing") to remove suspended particles.

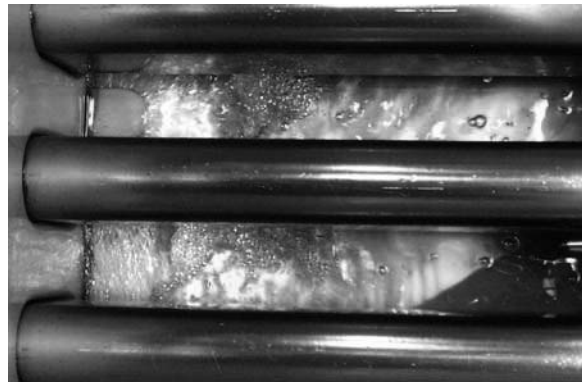

Polishing the oil removes suspended particles, which increases the life of the oil.

- After the filter cycle is complete, close the drain valve (push the red handle into the closed position until it stops) and allow the fryer to refill (see Step 4 above for additional reference).



After filtering is complete, close the red drain handle to start refilling the frypot.

SUFF/UFF FILTRATION SYSTEMS
CHAPTER 3: INSTALLATION AND OPERATION

3.4.2 Filter Operation (cont.)

9. After all oil is pumped back into the frypot, bubbles will form, indicating air in the oil return lines. Allow the oil to bubble for 10-15 seconds to ensure all oil is evacuated from the return lines. Push the yellow handle to close the oil return valve and deactivate the filter pump (see Step 5 above for additional reference).



Allow the oil to bubble for 10-15 seconds to ensure evacuation of all oil in the return lines.

10. If the oil level is low, add oil until the level is at the top OIL LEVEL line.

DO NOT OVERFILL THE FYPOT. This will cause oil to splash out of the frypot during cooking and may cause burns or damage.

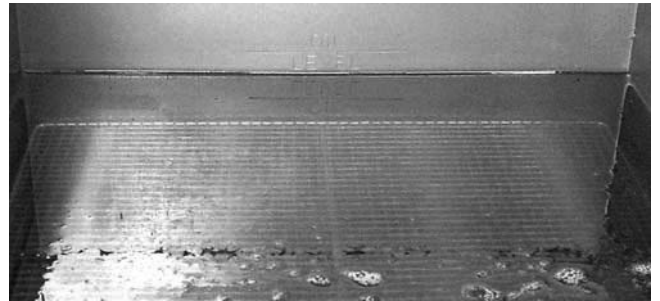

Add oil/shortening until the oil level is at the top OIL LEVEL line. DO NOT OVERFILL THE FRYPOT.

11. Replace the frypot grid, using care not to splash hot oil. Turn the fryer on.



Replace the frypot grid, using care not to splash hot oil.

SUFF/UFF FILTRATION SYSTEMS
CHAPTER 3: INSTALLATION AND OPERATION

3.4.2 Filter Operation (cont.)

12. Do not allow crumbs to accumulate in the crumb tray. The crumb tray **MUST** be emptied into a fireproof container at the end of frying operations **EACH DAY** (see **DANGER** statement below).

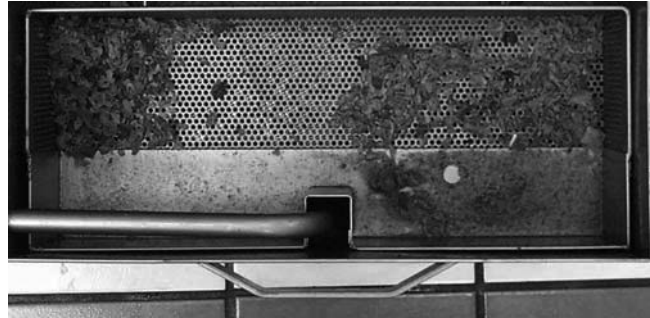

Empty the filter pan crumb tray into a fire-proof container at the end of frying operations each day. **DO NOT ALLOW CRUMBS TO ACCUMULATE IN TRAY.**

⚠ DANGER

The crumb tray in fryers equipped with a filter system must be emptied into a fireproof container at the end of frying operations each day. Some food particles can spontaneously combust if left soaking in certain shortening material.

⚠ WARNING

Do not bang fry baskets or other utensils on the fryer's joiner strip. The strip is present to seal the joint between the fry vessels. Banging fry baskets on the strip to dislodge shortening will distort the strip, adversely affecting its fit. It is designed for a tight fit and should only be removed for cleaning.

SUFF/UFF FILTRATION SYSTEMS

CHAPTER 3: INSTALLATION AND OPERATION

3.4.3 Hose and Wand Operation

Some frying systems come equipped with a hose/wand to facilitate the removal of debris from the frypot. On some systems, a blue handle activates the hose/wand flush. On other systems, the quick-disconnect is under positive pressure and has no ON/OFF valve. Plugging the hose into the disconnect activates the flush. On positive pressure systems, the oil flow can be moderated with the oil return valve (yellow handle). On blue-handle equipped systems, adjusting both the yellow and blue handles will moderate the oil flow. With partial pressure directed to the hose/wand, oil flows through both the filter pan and frypot.

1. Ensure the oil is at operating temperature (~350°F/~177°C). Turn the fryer off and open the fryer drain valve. Allow the oil to drain into the filter pan.

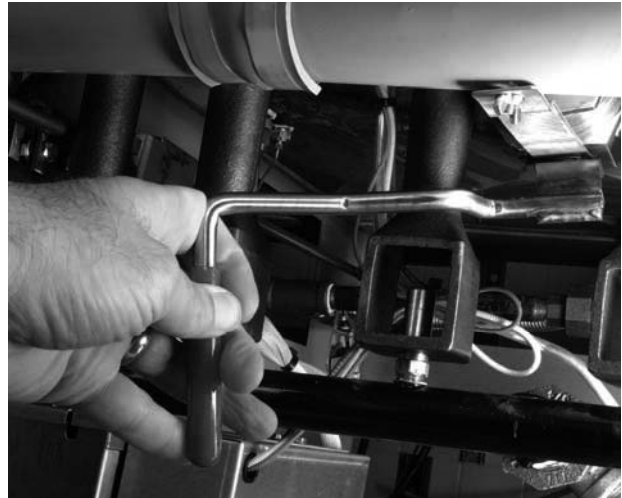

Moving the red drain valve handle to open the drain valve, allowing hot oil to drain into the filter pan.

2. When all the oil has drained from the frypot, connect the hose/wand assembly to the disconnect valve in the fryer cabinet. Ensure the disconnect is properly connected before proceeding.



Hose/wand disconnect properly connected to disconnect valve in fryer cabinet.

3. Place the wand into the open frypot and activate the filter with the auxiliary switch (rocker switch) inside the cabinet.

DO NOT PROCEED UNLESS THE WAND IS INSIDE THE FRYPOT. Hot oil can immediately flow from the wand when it is attached, causing burns if the wand is not in the frypot.



After the hose/wand end is properly positioned in the frypot, activate the filter pump with the auxiliary switch inside the cabinet (arrow).

SUFF/UFF FILTRATION SYSTEMS

CHAPTER 3: INSTALLATION AND OPERATION

3.4.3 Hose and Wand Operation (cont.)

4. If the quick-disconnect is under positive pressure (no ON/OFF valve), the oil will start to flow immediately into the frypot. If the flush valve is operated with a blue handle, pull the handle out to start oil flowing. **Keep the wand inside the frypot at all times while the filter pump is activated.**

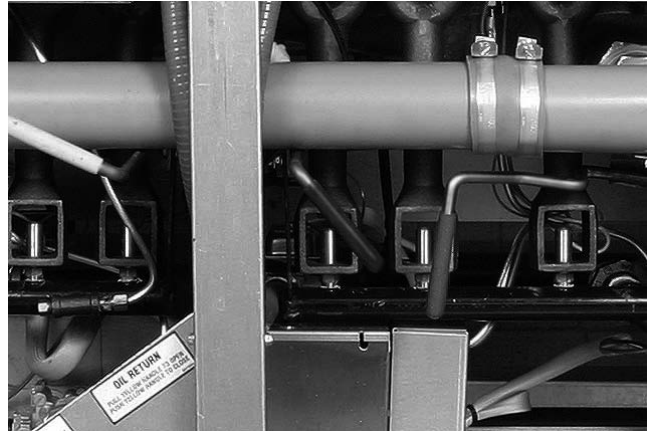

Pulling the blue handle opens the flush valve on fryers so equipped.

5. Rinse debris from the frypot into the filter pan with the wand. When cleanup is complete, push in the blue handle (if applicable), close the drain valve (red handle), and turn the auxiliary switch OFF. Allow hose/wand to drain into the filter pan.



Use the wand to rinse debris from the frypot into the filter pan. Maintain a firm grip on the wand handle at all times.

6. Refill the frypot by pulling the yellow handle to open the oil-return valve (this activates the filter pump automatically).

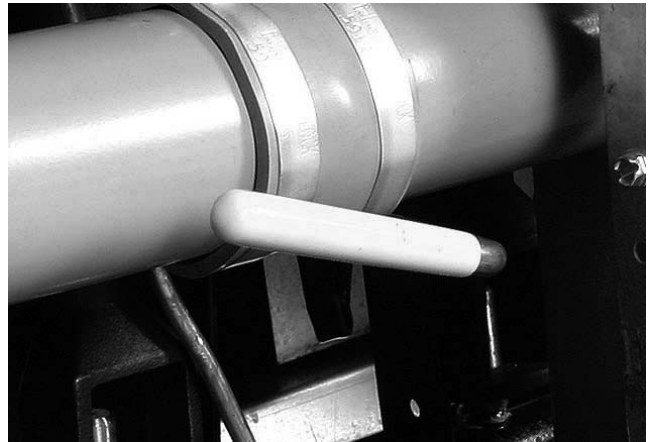

Return filtered oil to the frypot by pulling yellow handle to open oil return valve.

SUFF/UFF FILTRATION SYSTEMS

CHAPTER 3: INSTALLATION AND OPERATION

3.4.3 Hose and Wand Operation (cont.)

7. After the frypot refills, allow the oil to bubble for 10-15 seconds to ensure evacuation of all oil from the oil return lines. Push in the yellow handle to close the oil-return valve and de-activate the filter pump. Filtration is complete. Filter another frypot or return the fryer to operation.



Bubbling oil indicates air flowing through the oil return lines. Do this for 10-15 seconds to ensure evacuation of oil from the return lines.

SUFF/UFF FILTRATION SYSTEMS

CHAPTER 4: CLEANING AND MAINTENANCE

4.1 General

Cleaning operations fall into three general categories:

- Wiping unit clean after each filter session;
- Cleaning filter or filter-leaf assembly, changing filter paper (systems without filter-leaf), and preparing the unit for the next day's business.
- Weekly cleaning to remove oil deposits and other particles.



Never operate the filter unit unless cooking oil is at operating temperature.

4.2 Each Filter Use

Every time the SUFF/UFF filter system is used:

- Wash down the insides of the filter pan with hot oil.
- Change the filter paper (not applicable to filter-leaf equipped systems; see CLEANING THE FILTER-LEAF ASSEMBLY below) after each filter session or at the end of the day. Scrape sediment from the filter paper after each frypot is filtered and dispose of it in a fireproof container.
- Wipe away any oil.
- Wipe all exterior surfaces of the filter unit.

CLEANING THE FILTER-LEAF ASSEMBLY

Filters equipped with a filter-leaf require specific cleaning and assembly procedures. In the absence of cleaning and disassembly/reassembly instructions shipped with the filter-leaf, use the following procedure (see illustration on next page):

Grasp the seal frame near each corner at the locking tab (①) and pull frame apart. The seal frame will separate into two pieces. Separate the top and bottom screens (② and ③) and remove the grid (④). Assemble in reverse order (see illustration on next page).

Clean the two seal frame pieces, screens and grid using a good quality degreaser and hot water from a spray nozzle. The groove in the seal frame pieces can be cleaned with the edge of a Scotch-Brite™ type cleaning pad.

SUFF/UFF FILTRATION SYSTEMS CHAPTER 4: CLEANING AND MAINTENANCE

4.2 Each Filter Use (cont.)

At each scheduled boil-out, disassemble the filter-leaf as described and place in the frypot filled with boil-out solution (where applicable). Follow the boil-out procedure in the Installation and Operation manual included with the fryer. After boil out is complete, place the filter-leaf in a vinegar solution (1 pint vinegar to 1/2 gallon water) to neutralize boil-out residue. Rinse the filter-leaf in clean water to rinse away vinegar residue.

Allow all filter-leaf components to air dry or thoroughly dry with paper towels.

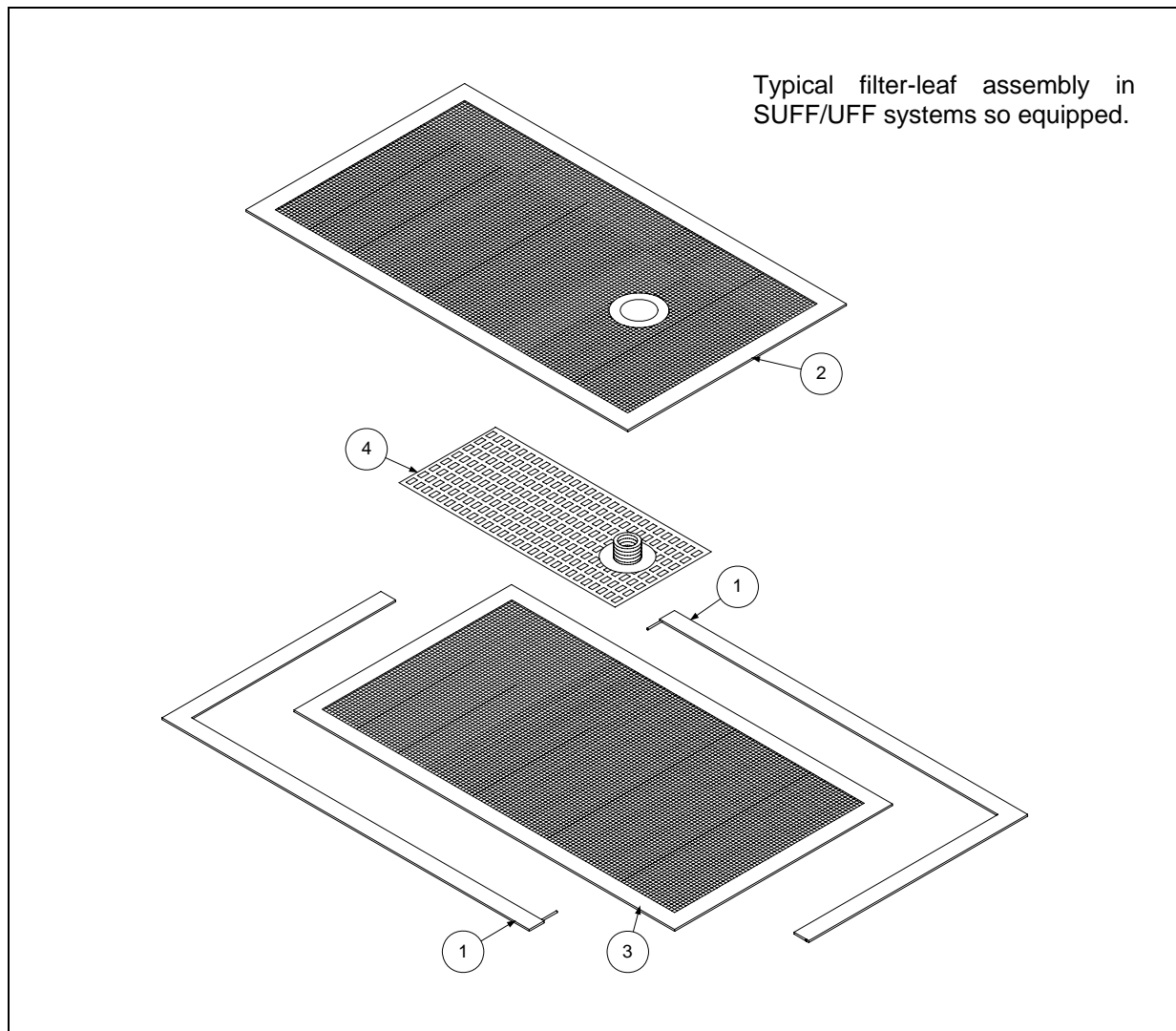

⚠ CAUTION

Do not run water or boil-out solution through the filtration system. Doing so will cause irreparable damage to the pump, and the warranty will be voided.

SUFF/UFF FILTRATION SYSTEMS CHAPTER 4: CLEANING AND MAINTENANCE

4.3 Daily (Close of Business)

At the close of a working day, oil in all fryers should be filtered. When the last fryer is finished, follow these steps:

1. Ensure the flexible hose and pump lines are clear by running the filter pump for an additional 10–15 seconds after air bubbles start coming from the oil return line. Then drain the flexible hose into the filter pan (if equipped with a flush option).
2. Remove the filter pan cover and hold-down ring assembly (see Section 4.2 for filter-leaf instructions), then remove the filter paper and filter support screen.
3. Discard the filter paper into a fireproof container.
4. Wash all filter components with soapy water and rinse.
5. Dry all filter parts and filter pan thoroughly before reassembling.
6. Check all fittings at the rear of the filter unit; ensure that all fittings are properly tightened.

 **DANGER**

The crumb tray in SUFF/UFF filter systems MUST be emptied into a fireproof container at the end of frying operations each day. Some food particles can spontaneously combust if left soaking in certain shortening material.

4.4 Weekly

Follow the same procedure as for Daily (Close of Business), with these additional steps:

- Wash the filter pan with hot, soapy water and a brush. Dry and reassemble with new filter paper.
- Clean thoroughly under, around, and behind the fryers and filtering area.
- Do not operate motor/pump until all traces of water have been removed from the pan. Under no circumstances should water or boil-out solution be allowed to enter the pump housing; irreparable damage will result, and all warranties will be voided.
- Check the connections of the inlet lines and tighten if lines become loose or start to leak oil.

SUFF/UFF FILTRATION SYSTEMS

CHAPTER 5: TROUBLESHOOTING

5.1 Troubleshooting Guide

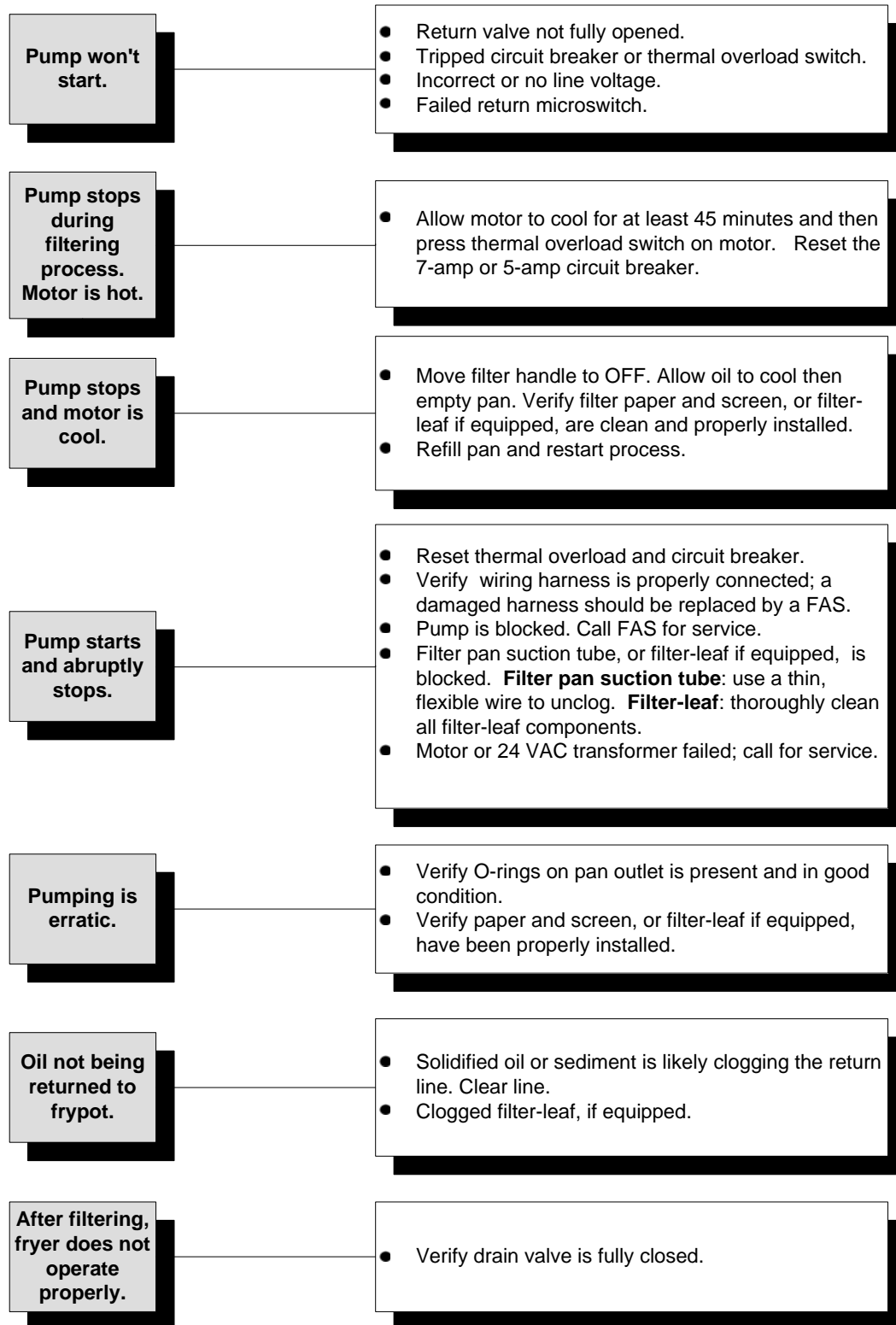

SUFF/UFF FILTRATION SYSTEMS

CHAPTER 6: PARTS LIST

6.1 SUFF 80 BID80 Series

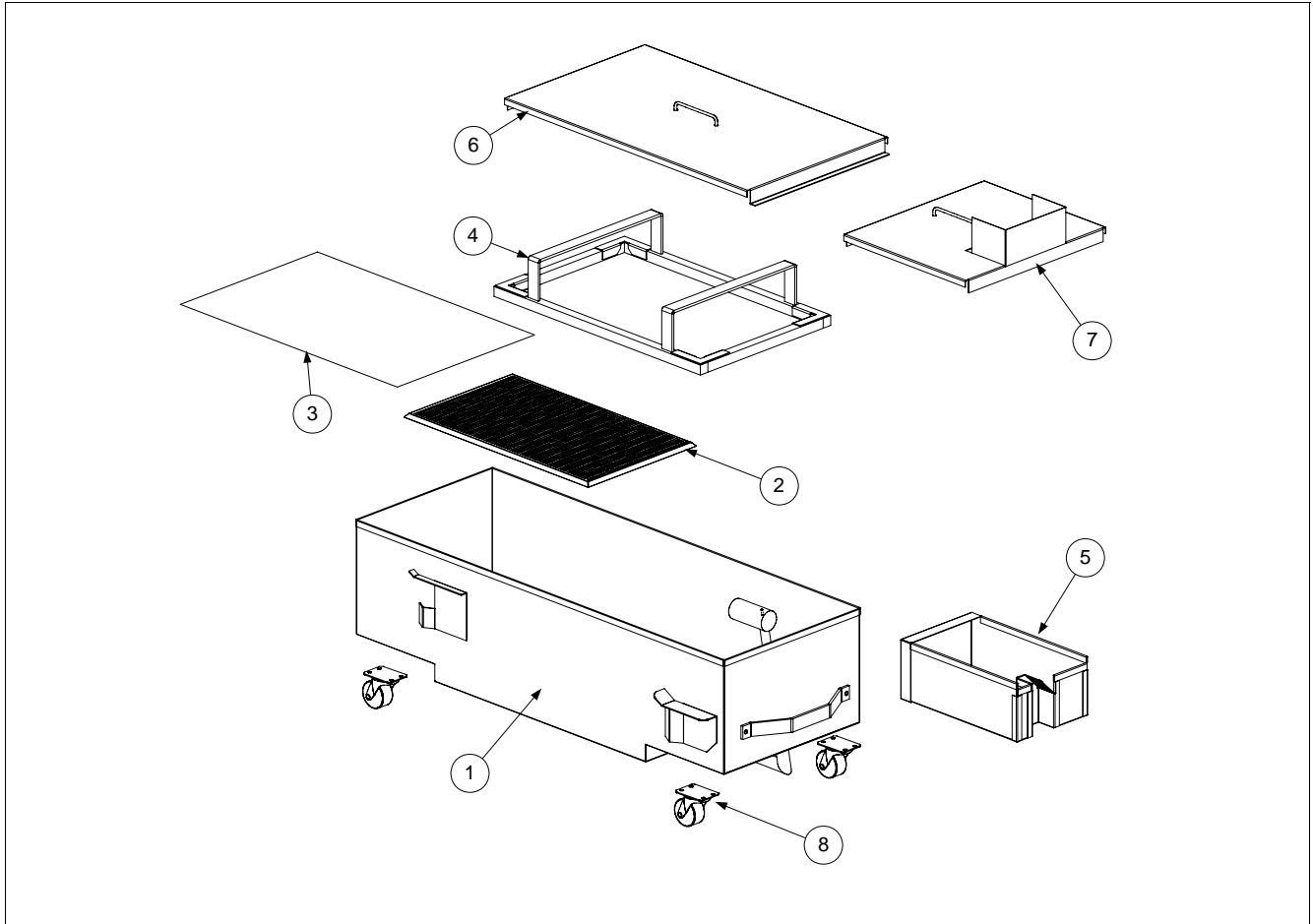

ITEM	PART #	COMPONENT
1	823-3750SP	Filter Pan Assembly- BID80 SUFF 80
*	813-0684	Plug, Hex Socket, 3/8" NPT
*	813-0679	Plug, 1/8" SS Square Head (Female Disconnect)
2	823-3748	Grid, Bottom- Filter Pan- BID80 SUFF 80
3	803-0289	Paper, Filter- 22 x 34"
4	823-3742	Ring, Hold-Down (Weighted)- BID80 SUFF 80
5	823-3736	Basket (Tray), Crumb
6	823-3741	Lid, Pan- Rear- SUFF 80
7	823-3739	Lid, Pan- Front- SUFF 80
8	810-2141	Caster, Swivel- 2"

* Not Illustrated

**SUFF/UFF FILTRATION SYSTEMS
CHAPTER 6: PARTS LIST**

6.2 SUFF 80 Domestic (Early Style)

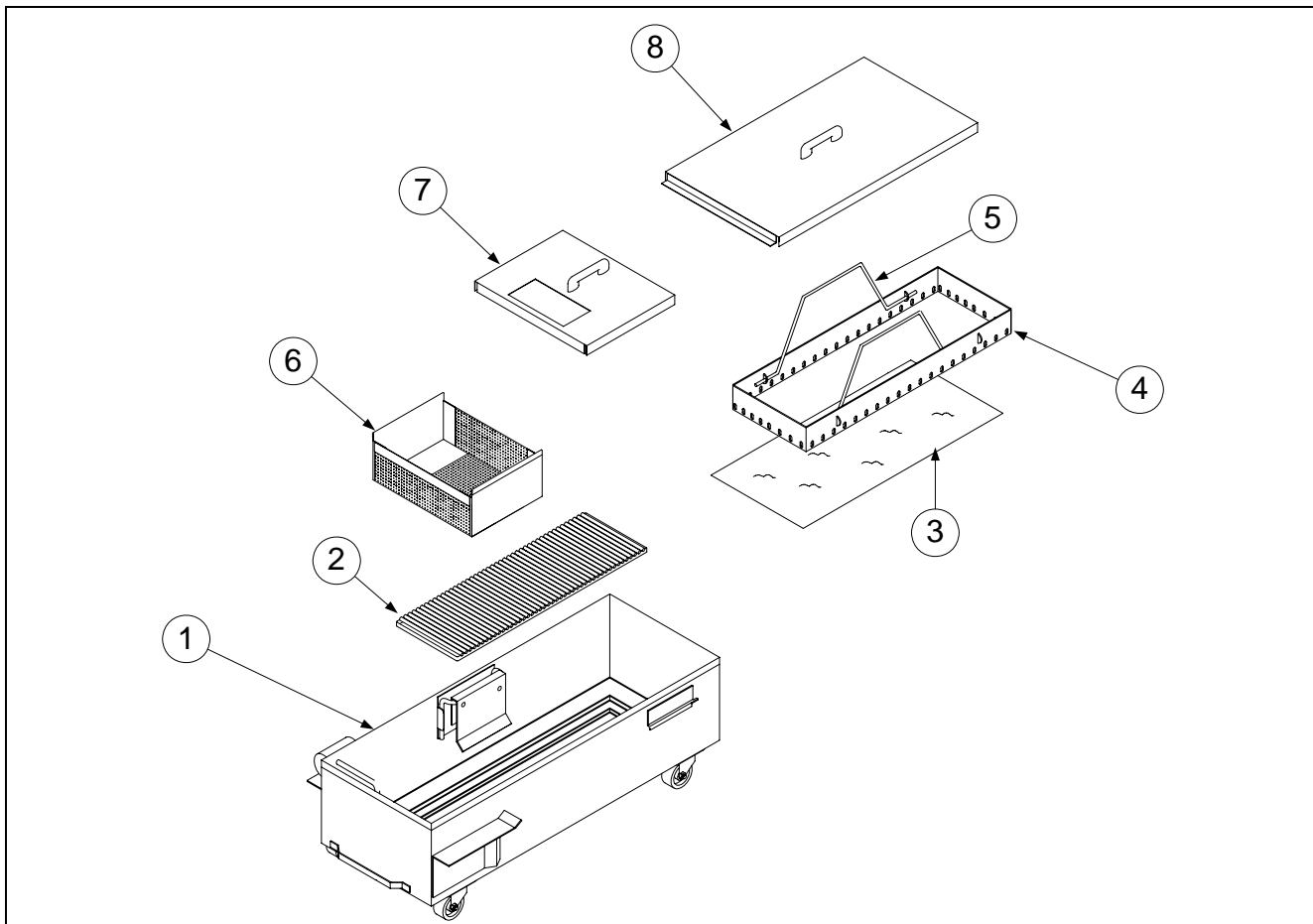

ITEM	PART #	COMPONENT
1	823-3388	Filter Pan Assembly
*	813-0679	Plug, 1/8 S/S
*	810-2141	Caster, Swivel- 2"
2	810-2212	Grid, Bottom- Filter Pan
3	803-0289	Paper, Filter- 22 x 34"
4	823-3387	Ring, Hold-Down (Without Handles)
5	823-3202	Handle, Hold-Down Ring
6	823-3392	Crumb Screen
7	106-1457SP	Lid, Pan- Front
8	106-1458SP	Lid, Pan- Rear

* Not Illustrated

**SUFF/UFF FILTRATION SYSTEMS
CHAPTER 6: PARTS LIST**

6.3 SUFF 80 Domestic (Current Style)

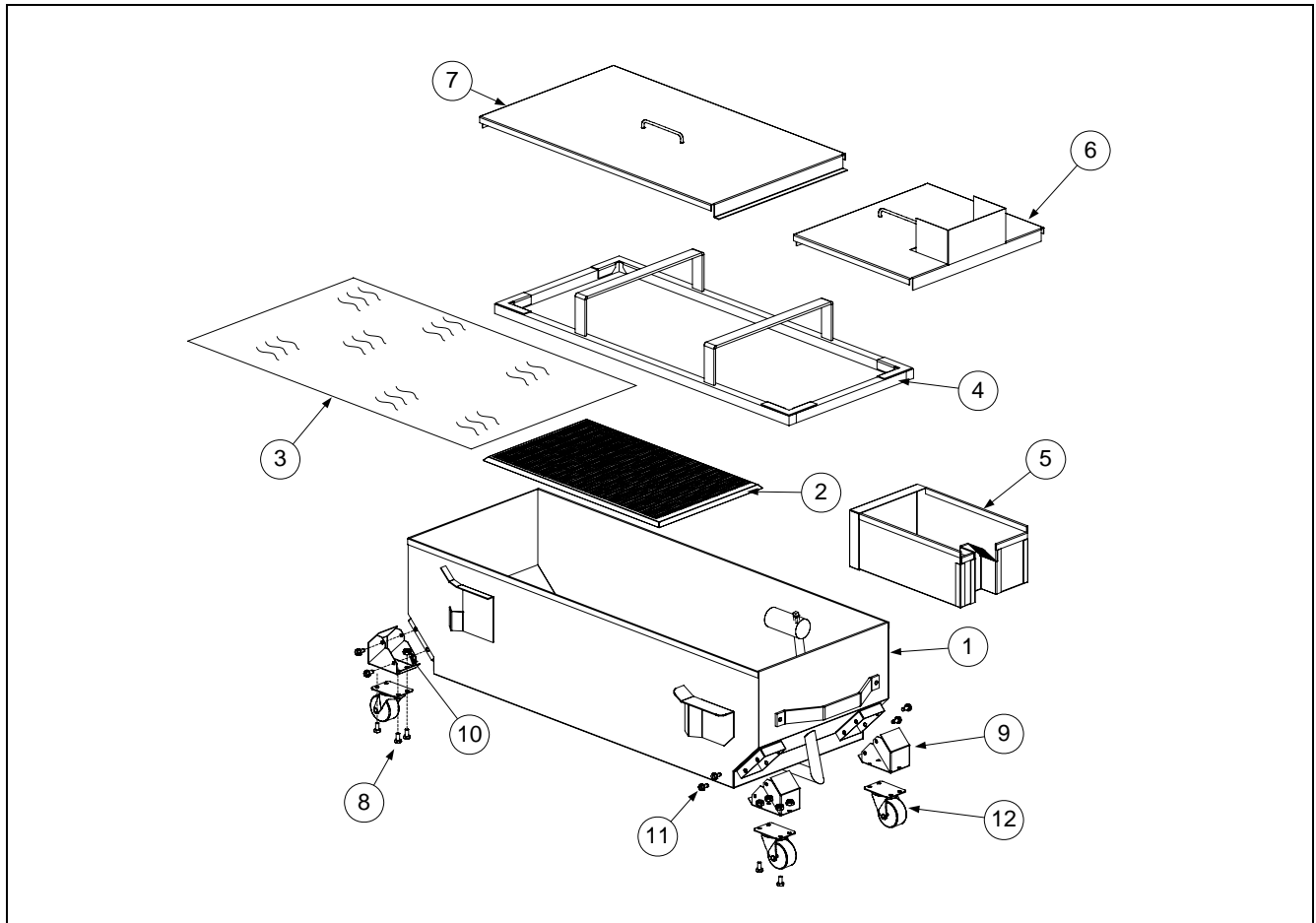

ITEM	PART #	COMPONENT
1	823-3821	Filter Pan, SUFF 80 Domestic
*	813-0684	Plug, Hex Socket, 3/8" NPT
*	813-0679	Plug, 1/8" SS Square Head (Female Disconnect)
2	823-3768	Support Grid (Bottom Pan Screen)
3	803-0289	Paper, Filter- 22 x 34"
4	823-3849	Hold-down Ring, Weighted
5	823-3736	Crumb Basket
6	823-3739	Filter Pan Cover, Front
7	823-3741	Filter Pan Cover, Back
8	809-0822	Bolt, 1/4-20 x 1/2" Steel
9	210-2291	Insert, Caster
10	809-0820	Nut, Oval Locking- 1/4-20
11	809-0805	Screw, 1/4-20 x 1/2"
12	▶▶▶	See Section 6.12 for Correct Caster Identification
* Not Illustrated		

**SUFF/UFF FILTRATION SYSTEMS
CHAPTER 6: PARTS LIST**

6.4 SUFF 60 (Current Production - Domestic and 18UE/BIH1721)

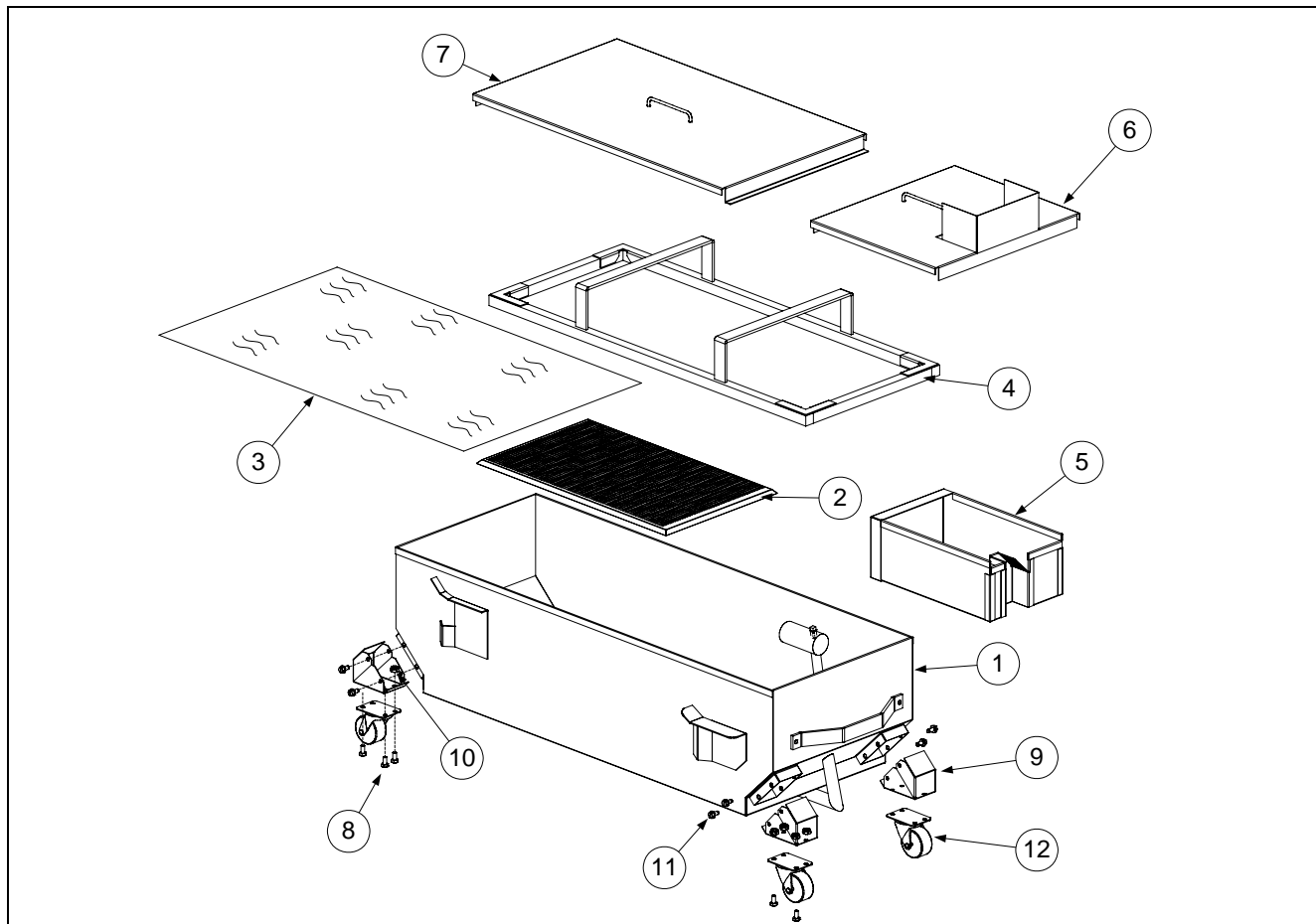

ITEM	PART #	COMPONENT
1	106-2228SP	Filter Pan, SUFF 60 Domestic
*	106-2225SP	Filter Pan, SUFF 60 18UE/BIH1721
*	813-0684	Plug, Hex Socket, 3/8" NPT
*	813-0679	Plug, 1/8" SS Square Head (Female Disconnect)
2	823-3768	Support Grid (Bottom Pan Screen)- SUFF 60 Domestic
*	823-3769	Support Grid (Bottom Pan Screen)- SUFF 60 18UE/BIH1721
3	803-0289	Paper, Filter- 22 x 34"
4	823-3768	Hold-Down Ring, Weighted- SUFF 60 Domestic
*	823-3768	Hold-Down Ring, Weighted- SUFF 60 18UE/BIH1721
5	823-3736	Crumb Basket, All SUFF 60
6	823-3766	Filter Pan Cover, Front- All SUFF 60
7	823-3767	Filter Pan Cover, Back- All SUFF 60
8	809-0822	Bolt, 1/4-20 x 1/2" Steel (SUFF 60 Domestic)
9	210-2291	Insert, Caster (SUFF 60 Domestic)
10	809-0820	Nut, Oval Locking- 1/4-20
11	809-0805	Screw, 1/4-20 x 1/2" (SUFF 60 Domestic)
12	▶▶▶	See Section 6.12 for Correct Caster Identification

* Not Illustrated

**SUFF/UFF FILTRATION SYSTEMS
CHAPTER 6: PARTS LIST**

6.5 SUFF 50 (Early Style)

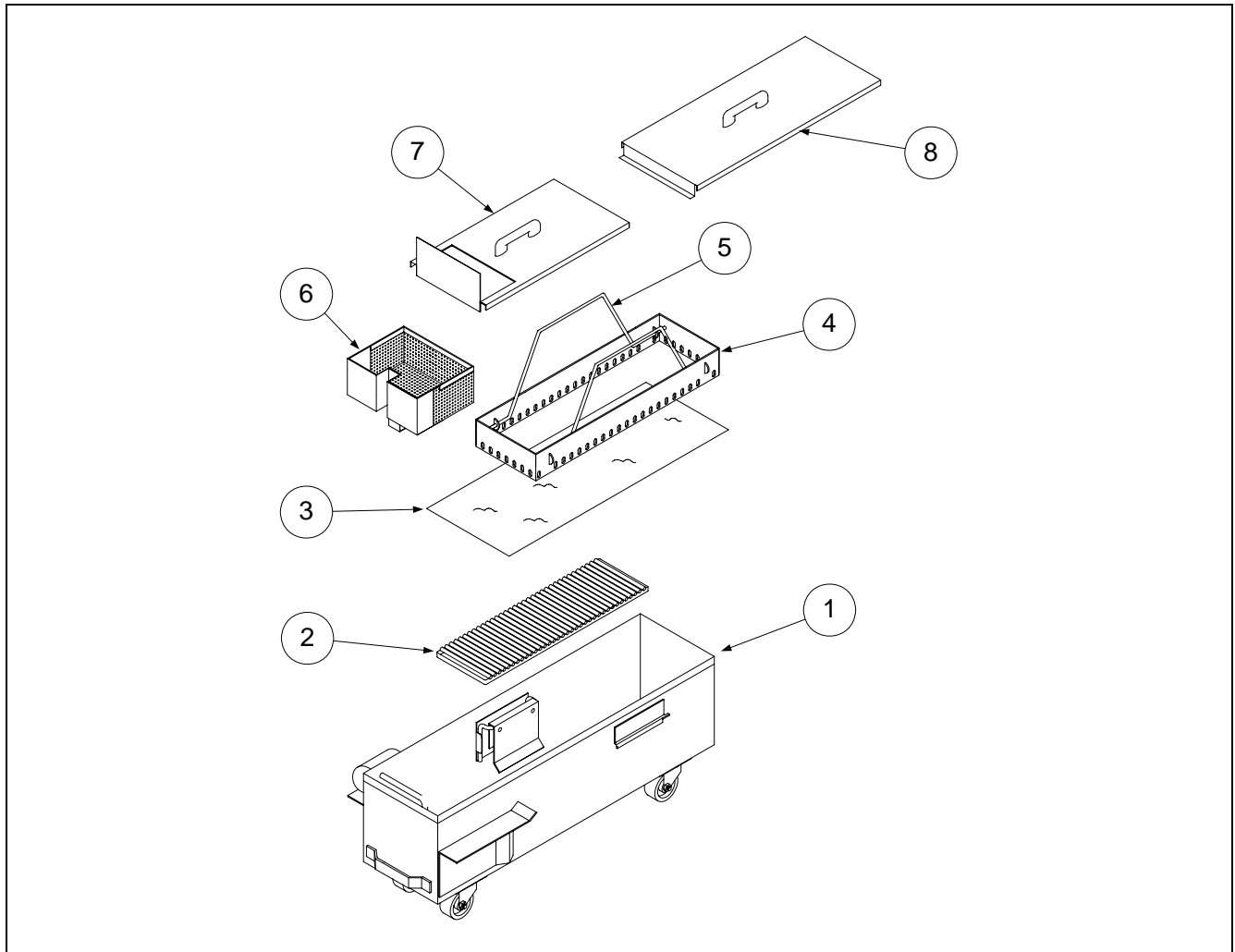

ITEM	PART #	COMPONENT
1	55548-1	Filter Pan Assembly
*	813-0679	Plug, 1/8 S/S
2	803-0330	Grid, Bottom- Filter Pan
3	803-0317	Paper, Filter- 8- $\frac{1}{4}$ x 25- $\frac{3}{4}$ "
4	55559	Ring, Hold-Down (Without Handles)
5	823-3736	Handle, Hold-Down Ring
6	55561	Crumb Screen
7	55557	Lid, Pan- Front
8	210-1905	Lid, Pan- Rear
*	810-2105	Handle, Pan Lid- Front and Rear (With Screws)
*	810-2141	Caster, Swivel- 2"

* Not Illustrated

**SUFF/UFF FILTRATION SYSTEMS
CHAPTER 6: PARTS LIST**

6.6 SUFF 50 (Current Style)

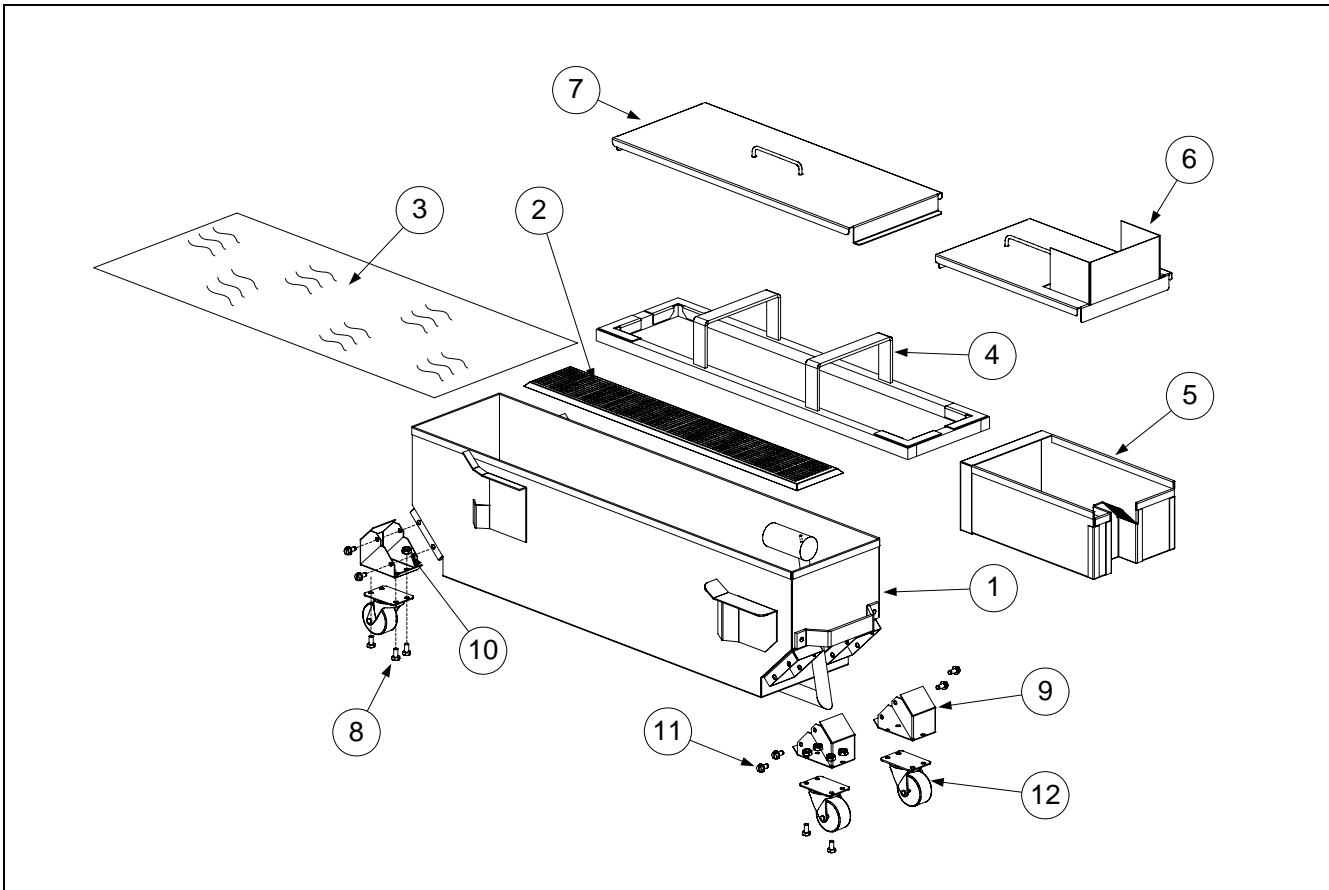

ITEM	PART #	COMPONENT
1	823-3796	Filter Pan, SUFF 50
*	813-0684	Plug, Hex Socket, 3/8" NPT
*	813-0679	Plug, 1/8" SS Square Head (Female Disconnect)
2	823-3790	Support Grid (Bottom Pan Screen)
3	803-0317	Paper, Filter- 8- ¹ / ₄ x 25- ³ / ₄ "
4	823-3795	Hold-Down Ring, Weighted
5	823-3736	Crumb Basket
6	823-3797	Filter Pan Cover, Front
7	823-3798	Filter Pan Cover, Back
8	809-0822	Bolt, 1/4-20 x 1/2" Steel
9	210-2291	Insert, Caster
10	809-0820	Nut, Oval Locking- 1/4-20
11	809-0805	Screw, 1/4-20 x 1/2"
12	▶▶▶	See Section 6.12 for Correct Caster Identification

* Not Illustrated

SUFF/UFF FILTRATION SYSTEMS
CHAPTER 6: PARTS LIST

6.7 Super Cascade 75 (Early Style)

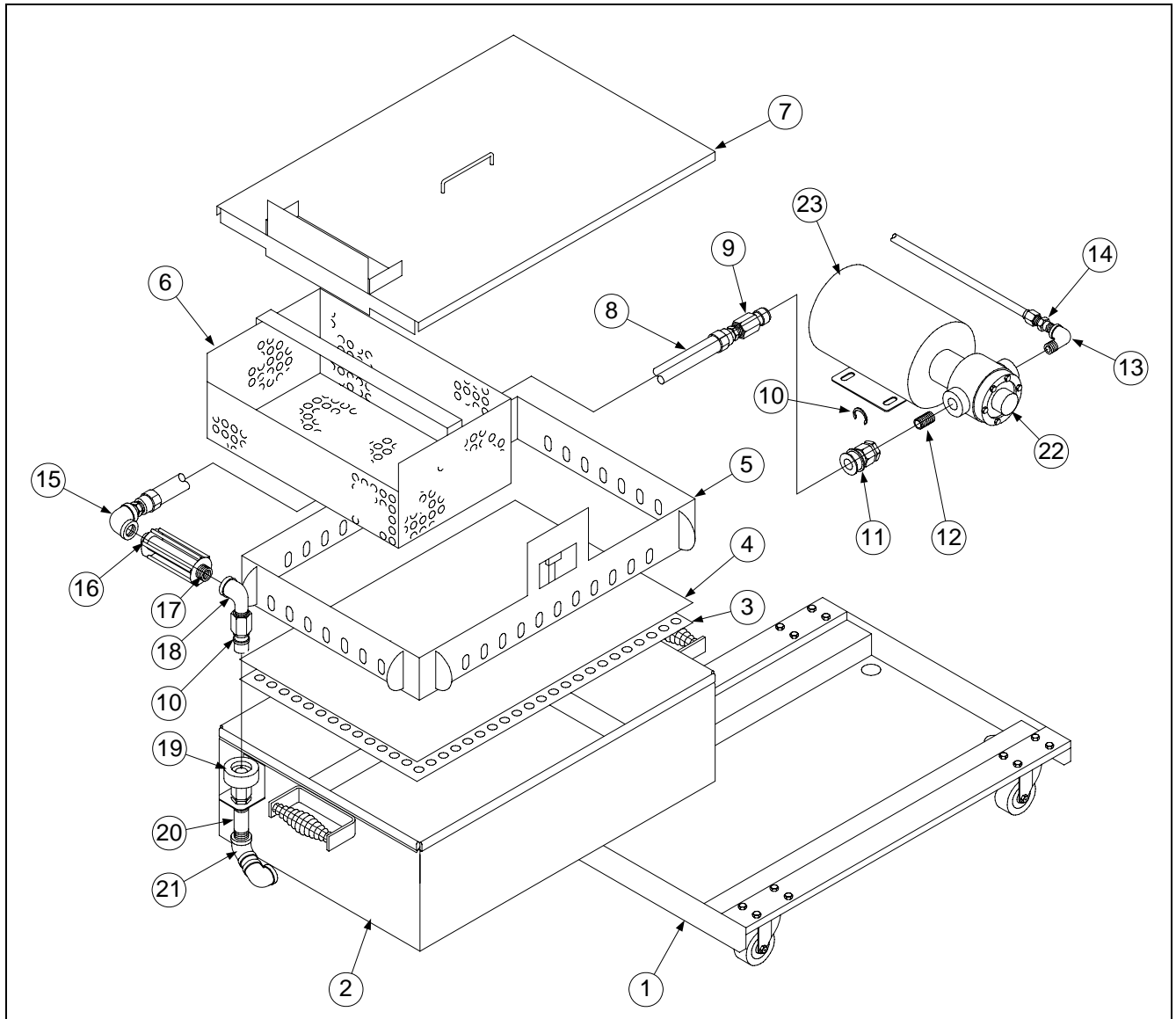

**SUFF/UFF FILTRATION SYSTEMS
CHAPTER 6: PARTS LIST**

6.7 Super Cascade 75 (Early Style) (cont.)

ITEM	PART #	COMPONENT
1	106-2613SP	Caddy Assembly, Filter Pan
*	200-3992	Caddy, Filter Pan
*	810-0006	Caster, Swivel
*	809-0822	Bolt, ¼-20 x ½" Hex
*	809-0823	Nut, Nylock- ¼-20
*	809-0816	Screw, 10-16 x ½"
2	823-3984	Pan, Filter
3	810-2329	Grid, Wire- Bottom
4	803-0170	Paper, Filter- 16-½ x 25-¾"
5	823-3632	Ring, Hold-Down
6	823-3720	Screen (Basket), Crumb
7	823-3985	Lid, Filter Pan
8	810-2372	Hose Assembly
9	810-2170	Disconnect, Male- ½"
10	810-2246	Ring, Retaining- 1"
11	810-2173	Disconnect, Female- ½"
*	816-0545	O-ring, Female Disconnect
12	813-0022	Nipple, ½" x Close
13	813-0165	Elbow, Street- ½" x 90° NPT BM
14	813-0613	Flare Fitting, ½-37° x ½"
15	1011SS	Elbow, ½" x 90° S/S
16	44681	Handle Assembly, Oil Return
17	813-0761	Nipple, ½ x 5" NPT S/S
18	813-0616	Elbow, Street- ½" x 90° NPT S/S
19	809-0807	Collar, Disconnect (See Item #12 For Disconnect)
20	813-0265	Nipple, ½ x 2-½" BM NPT
21	813-0345	Elbow, ½" x 45° BM NPT
*	813-0281	Nipple, ½ x 5" BM NPT
22	810-2098	Pump, Filter- 8 GPM
*	810-2252	Pump, Filter- 5 GPM
23	810-2100	Motor, Filter Pump- 120/230V 1/3 HP

* Not Illustrated

**SUFF/UFF FILTRATION SYSTEMS
CHAPTER 6: PARTS LIST**

6.8 UFF Components D50 and D60 Series Fryers (Current Production)

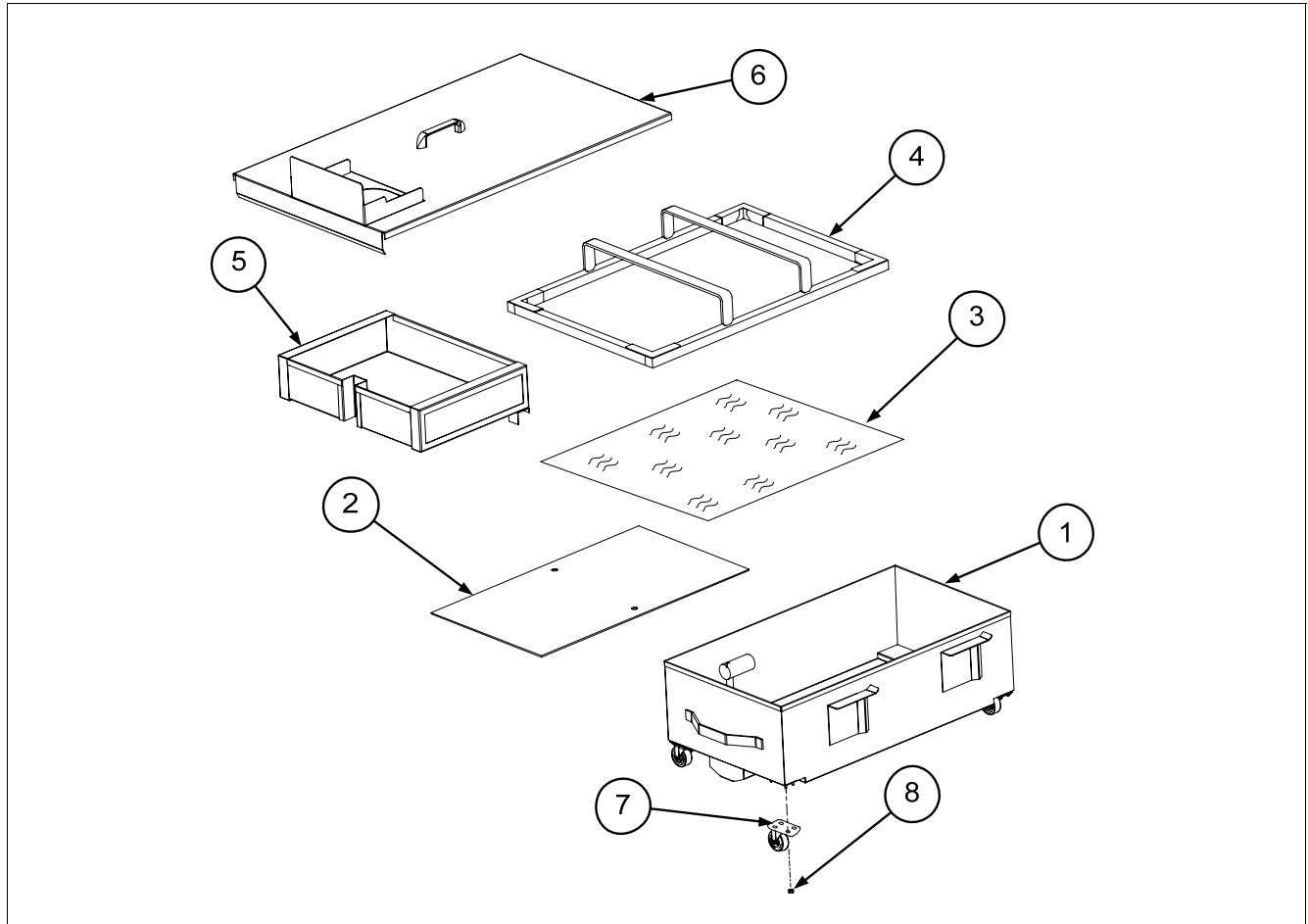

ITEM	PART # (3" drains)	PART # (1.5" drains)	COMPONENT
1		823-3576	Filter Pan (UFF 50)
*	106-5517	106-0749SP	Filter Pan (UFF 60)
2		823-3574	Support Grid, Bottom Pan Screen (UFF 50)
*	200-5726	823-3365	Support Grid, Bottom Pan Screen (UFF 60)
3	803-0289	803-0289	Filter Paper, 22" x 34", qty: 100 sheets/box (UFF 50/60)
4		823-3573	Hold-down Ring, Weighted (UFF 50)
*	823-3361	823-3361	Hold-down Ring, Weighted (UFF 60)
5	823-4320	823-4320	Crumb Basket (UFF 50/60)
6	106-4725		Lid Assembly, One Piece (UFF SCFD)
*		106-0752SP	Lid Assembly, Front (UFF 50/60)
*		106-1755SP	Lid Assembly, Rear (UFF 50)
*		106-0753SP	Lid Assembly, Rear (UFF 60)
7	810-2805	810-2805	Caster, 2" Swivel
*		823-4794	Insert, Caster
8	809-0070		Nut, 1/4-20 Hex SS
*		809-0805	Screw, 1/4-20 x 1/2"
*		809-0428	Bolt, 1/4-20 x 1/2" Steel
*		809-0820	Nut, 1/4-20 Locking

* Not illustrated.

SUFF/UFF FILTRATION SYSTEMS
CHAPTER 6: PARTS LIST

6.9 UFF Components D50 and D60 Series Fryers (Previous Production)

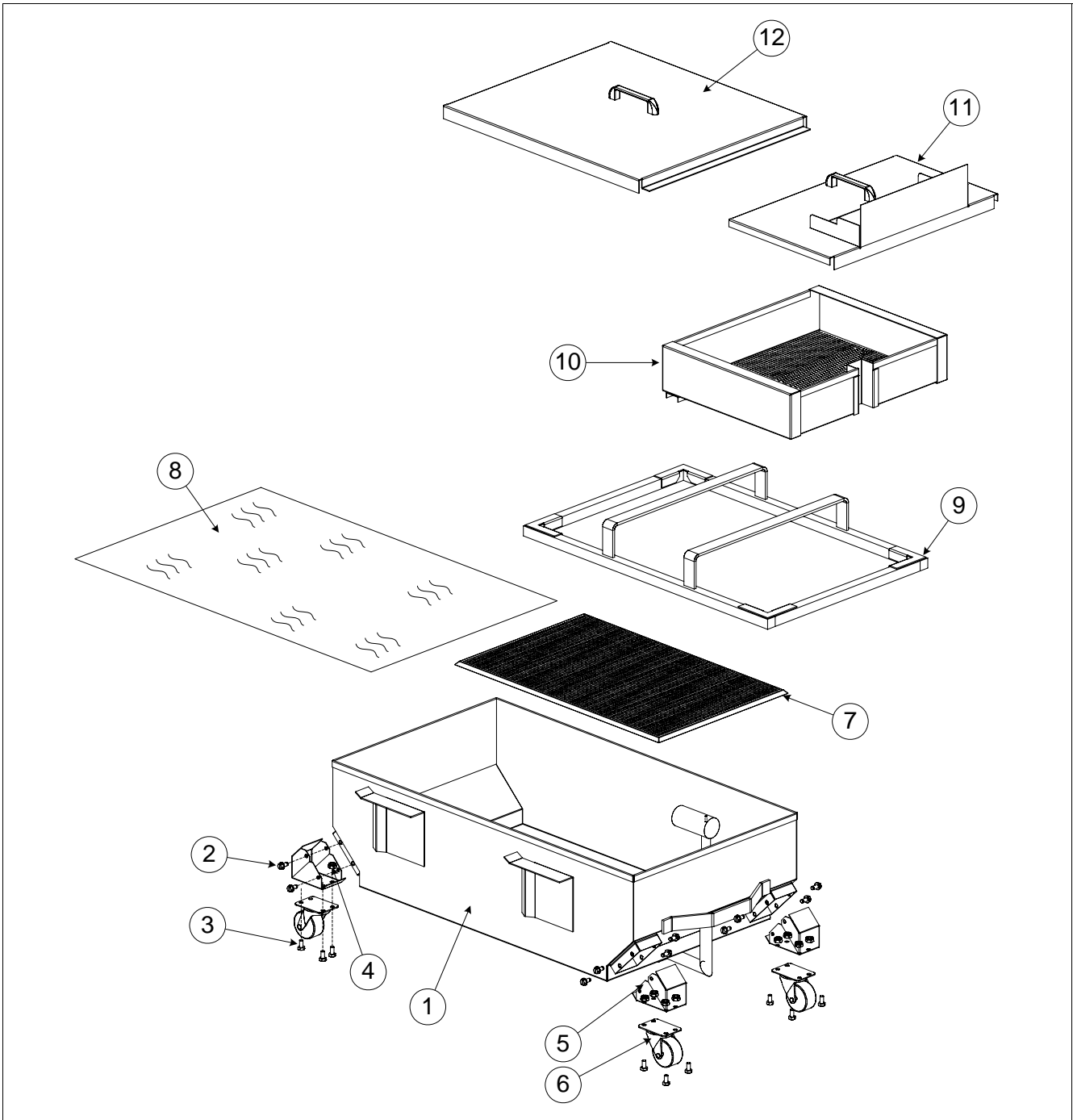

**SUFF/UFF FILTRATION SYSTEMS
CHAPTER 6: PARTS LIST**

**6.9 UFF Components D50 and D60 Series Fryers (Previous Production)
(cont.)**

ITEM	PART #	COMPONENT
1	106-2115SP	Filter Pan- UFF 50 (Includes Items 2-6)
*	106-2109SP	Filter Pan- UFF 50 IHOP (Includes Casters)
*	106-0749SP	Filter Pan- UFF 60 (Includes Items 2-6)
2	809-0805	Screw, ¼-20 x ½"
3	809-0822	Bolt, ¼-20 x ½" Steel
4	809-0820	Nut, Oval Locking- ¼-20
5	210-2291	Insert, Caster
6	▶▶▶	See Section 6.12 for Correct Caster Identification
7	823-3574	Support Grid (Bottom Pan Screen)- UFF 50
7	823-3365	Support Grid (Bottom Pan Screen)- UFF 60
8	803-0289	Filter Paper, 22 x 34"- UFF 50/60 (100 Sheets)
*	810-2350	Magnesol Filter Screen, UFF 50 IHOP
*	810-2351	Handle, Magnesol Filter Screen Tee, UFF 50 IHOP
9	823-3573	Hold-down Ring, Weighted- UFF 50 (Not Required On IHOP)
*	823-3361	Hold-down Ring, Weighted- UFF 60
10	823-3175	Crumb Basket, UFF 50/60
*	823-3872	Crumb Basket, UFF 50 IHOP
11	106-0752SP	Lid Assembly, Front- UFF 50/60- All
12	106-1755SP	Lid Assembly, Rear- UFF 50 (Except IHOP)
*	106-0753SP	Lid Assembly, Rear- UFF 60 & UFF 50 IHOP

* Not Illustrated

SUFF/UFF FILTRATION SYSTEMS
CHAPTER 6: PARTS LIST

6.10 KFC 218G/E UFF (2002)

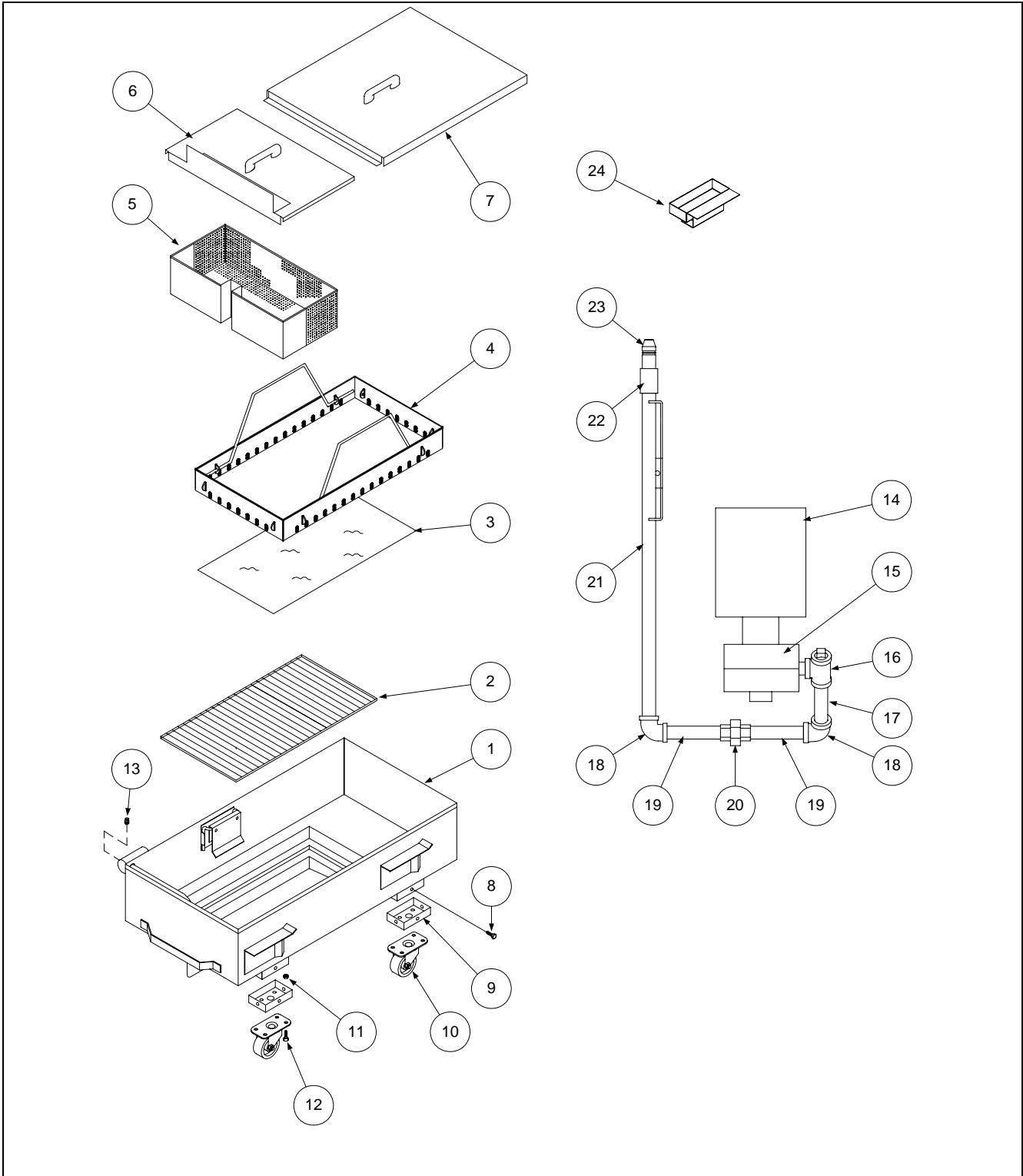

**SUFF/UFF FILTRATION SYSTEMS
CHAPTER 6: PARTS LIST**

6.10 KFC 218G/E UFF (2002) (cont.)

ITEM	PART #	COMPONENT
1	823-3240	Pan, Filter- KFC 18G/E
2	810-2119	Grid, Filter- KFC 18G/E
3	803-0170	Paper, Filter- 16- $\frac{1}{2}$ x 25- $\frac{3}{4}$ "
4	823-3201	Ring, Hold-Down (No Handles)- KFC 18G/E
*	823-3202	Handle, Hold-Down Ring- KFC 18G/E
5	823-3204	Crumb Basket- KFC 18G/E
6	106-0903SP	Lid, Filter Pan- Front
7	106-0905SP	Lid, Filter Pan- Back
8	809-0866	Screw, SS- $\frac{1}{4}$ -10 x $\frac{1}{2}$ " Phillips Head
9	210-1293	Insert, Mounting Plate- Caster
10	810-0006	Caster, 2"
11	809-0823	Nut, Nylock- $\frac{1}{4}$ -20
12	809-0822	Bolt, $\frac{1}{4}$ -20 x $\frac{1}{2}$ " Hex Head
13	813-0679	Plug, SS- 1/8 Square Head
14	810-2100	Motor, Filter Pump
15	810-2098	Pump, Filter
16		Fitting, Oil Suction Start
*	813-0022	Nipple, $\frac{1}{2}$ " NPT x Close BM
*	813-0003	Tee, $\frac{1}{2}$ " NPT BM
*	813-0156	Plug, $\frac{1}{2}$ " NPT BM
17	813-0674	Nipple, $\frac{1}{2}$ " NPT x 7- $\frac{1}{4}$ "
18	813-0062	Elbow, $\frac{1}{2}$ " x 90°
19	813-0247	Nipple, $\frac{1}{2}$ " NPT x 3- $\frac{1}{2}$ "
20	813-0173	Union, $\frac{1}{2}$ " NPT BM
21	823-3282	Tube, Suction Assembly
22	813-0608	Coupling, Full
23	810-0697	Disconnect, Male
*	826-1392	O-Ring, Disconnect (Qty: 5)
24	106-0820SP	Drip Cup Assembly

* Not Illustrated

**SUFF/UFF FILTRATION SYSTEMS
CHAPTER 6: PARTS LIST**

6.11 UFF 80 (Current Style)

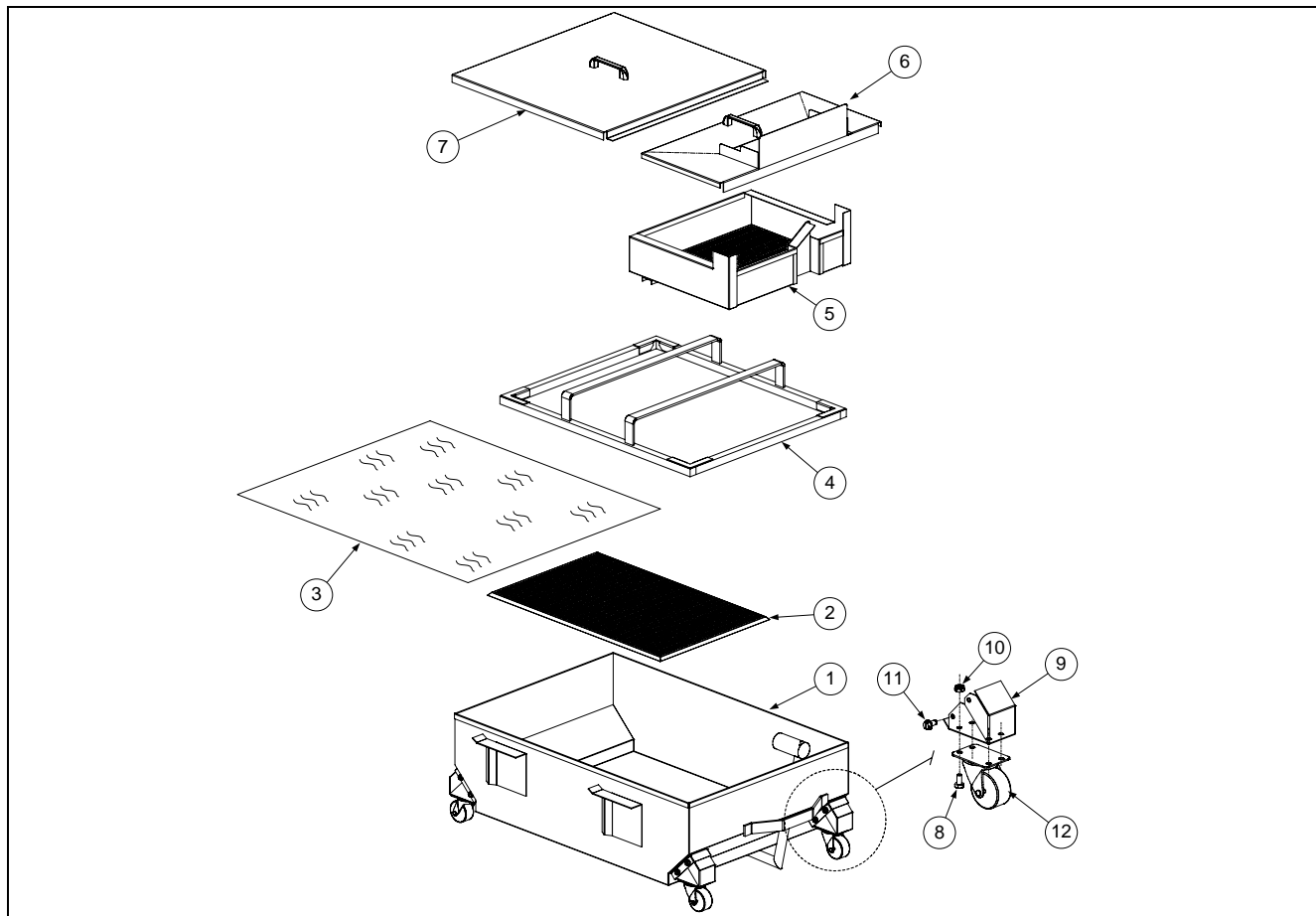

ITEM	PART #	COMPONENT
1	106-1584SP	Filter Pan, UFF 80
2	823-3365	Support Grid (Bottom Pan Screen)
3	803-0303	Filter Paper, 26 x 34" (100 Sheets)
4	823-3439	Hold-down Ring, Weighted
5	823-3443	Crumb Basket
6	106-1587SP	Filter Pan Cover, Front
7	106-1588SP	Filter Pan Cover, Back
8	809-0822	Bolt, ¼-20 x ½" Steel
9	210-2291	Insert, Caster
10	809-0820	Nut, Oval Locking- ¼-20
11	809-0805	Screw, ¼-20 x ½"
12	▶▶▶	See Section 6.12 for Correct Caster Identification

* Not Illustrated

SUFF/UFF FILTRATION SYSTEMS
CHAPTER 6: PARTS LIST

6.12 UFF 85 Filter-leaf Equipped Flatbottom (2424)

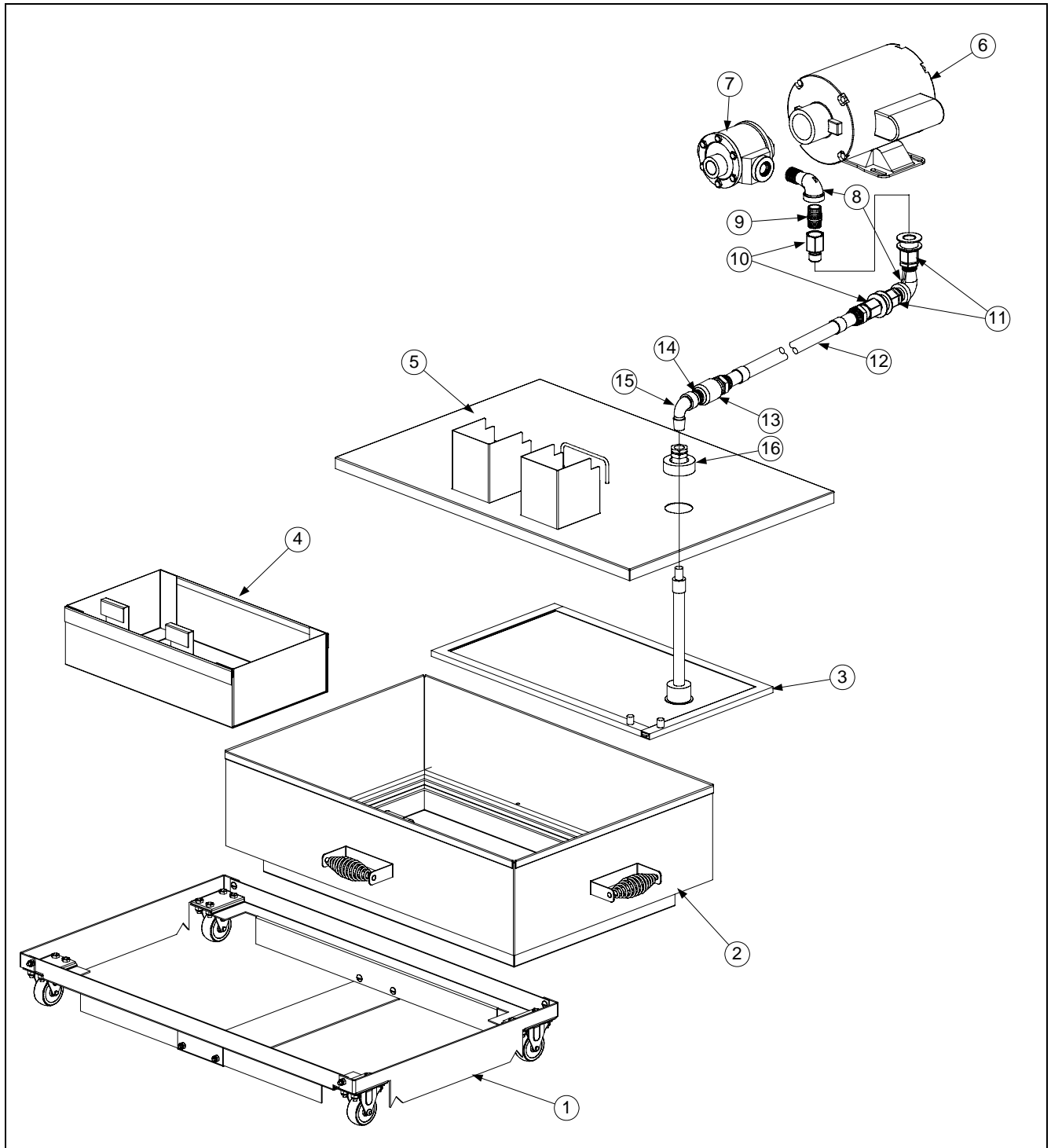

**SUFF/UFF FILTRATION SYSTEMS
CHAPTER 6: PARTS LIST**

6.12 UFF 85 Filter-leaf Equipped Flatbottom (2424) (cont.)

ITEM	PART #	COMPONENT
1	106-1693SP	Filter Pan Caddy Assembly
	810-0005	Caster, Rigid- 2"
	809-0822	Bolt, ¼-20 x ½" Hex Head
	809-0823	Lock Nut, ¼-20
*	106-2837SP	Bracket Assy, Filter Pan Holding
2	823-3480SP	Filter Pan With Fittings
3	810-2237	Filter Leaf with Compression Cap
	810-2172	Quick Disconnect, Male- 3/8"
4	823-3509	Crumb Basket, 85 UFF
5	823-3492	Lid Assembly, Filter Pan
6	810-2100	Motor, Pump- 1/3HP 230/120V/50/60HZ
7	810-2098	Pump, Filter- 8GPM
8	813-0165	Elbow, Street- ½" NPT 90° BM
9	813-0022	Nipple, ½" x Close NPT BM
10	810-2170	Disconnect, Male- ½"
11	810-2173	Disconnect, Female- ½"
12	810-2245	Hose Assembly- 16-¾"
13	813-0735	Reducer, Bell- ½ To 3/8"
14	813-0625	Nipple, 3/8" NPT x Close BM
15	813-0695	Elbow, Street- 3/8" NPT 90° BM
16	106-1831SP	Coupler Assembly, Female- 3/8"
	809-0807	Collar, Quick Disconnect
	810-2171	Quick Disconnect, Female- 3/8"
* Not Illustrated		

SUFF/UFF FILTRATION SYSTEMS CHAPTER 6: PARTS LIST

6.13 Casters and Accessories

Use the following diagram to properly replace casters on SUFF/UFF filter pans. Part number 810-0006 (Swivel Caster, 2-inch) was used in all SUFF/UFF applications except for BID80 SUFF 80, 18UE SUFF 60, BIH1721 SUFF 60 and IHOP UFF 50 *prior to June 1, 2002*. Part number 810-2141 (Swivel Caster, 2-inch) is used in all current production SUFF/UFF applications except for KFC 18G/E UFF filtration systems *after June 1, 2002*. *Beginning October, 2005*, part number 810-2805 is used for 50/60 UFF filtration systems casters. When in doubt, measure the distance between the mounting holes of the caster mounting plate and compare it to the illustrations below. Part number 810-0005 (Rigid Caster, 2-inch) is used exclusively in Flatbottom (24G) UFF filtration systems.

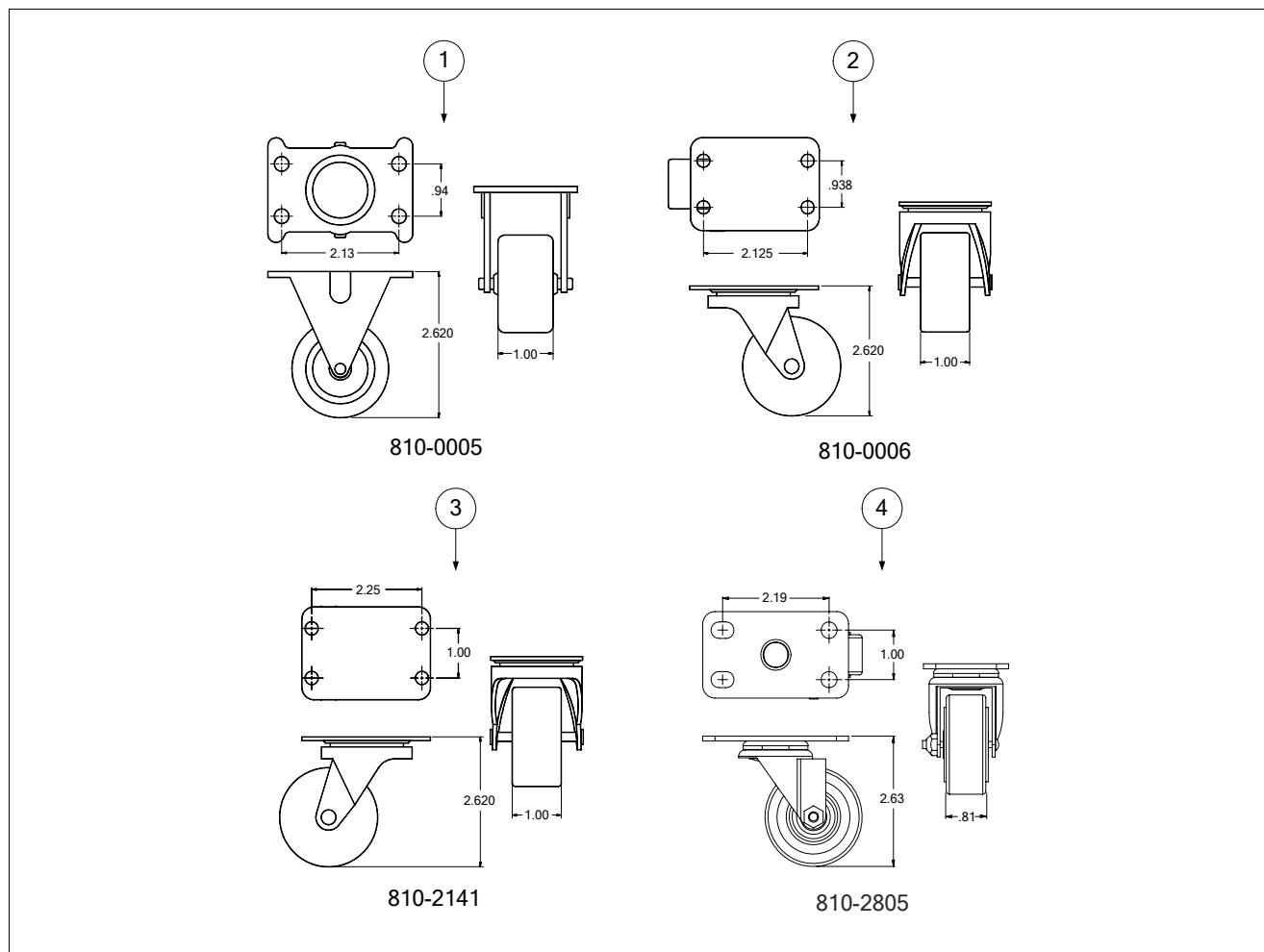

ITEM	PART #	COMPONENT
1	810-0005	Caster, Rigid- 2-inch
2	810-0006	Caster, Swivel- 2-inch
3	810-2141	Caster, Swivel- 2-inch
4	810-2805	Caster, Swivel- 2-inch
*	803-0002	Powder, Filter- Box (100 1-Cup Applications)
*	803-0209	Brush, Cleaning

* Not Illustrated

THIS PAGE INTENTIONALLY LEFT BLANK

 **Frymaster**  **Dean**

 **Manitowoc**

Frymaster L.L.C., 8700 Line Avenue, Shreveport, Louisiana 71106

TEL 1-318-865-1711

FAX (Parts) 1-318-688-2200

FAX (Tech Support) 1-318-219-7135

PRINTED IN THE UNITED STATES

SERVICE HOTLINE
1-800-551-8633

819-5809A
OCTOBER 2011