

# VT SERIES VERTICAL TOASTER SERVICE MANUAL

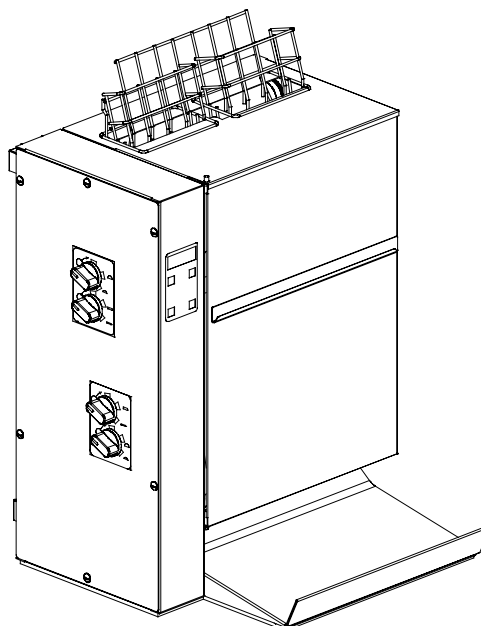

This equipment chapter is to be inserted in  
the Equipment Manual

**MANUFACTURED  
EXCLUSIVELY FOR  
McDONALD'S®  
BY FRYMASTER, L.L.C.  
P.O. BOX 51000  
SHREVEPORT, LOUISIANA 71135-1000  
PHONE 1 (318) 865-1711  
1 (800) 24 FRYER**



## TABLE OF CONTENTS

<b>1. WARRANTY STATEMENT</b> .....	<b>1</b>
1.1 WARRANTY PROVISIONS – VERTICAL TOASTER.....	1
1.2 PARTS RETURN.....	1
1.3 WARRANTY EXCLUSIONS.....	1
<b>2. PARTS ORDERING AND SERVICE INFORMATION</b> .....	<b>2</b>
<b>3. VERTICAL TOASTER OPERATIONAL DESCRIPTION</b> .....	<b>3</b>
<b>4. INSTALLATION/SETUP</b> .....	<b>3</b>
<b>5. OPERATION</b> .....	<b>3</b>
<b>6. VIEWING AND ADJUSTING THE SETPOINT</b> .....	<b>4</b>
<b>7. ADJUSTING BUN COMPRESSION</b> .....	<b>4</b>
<b>8. CHANGING BELTS</b> .....	<b>5</b>
<b>9. OPERATOR TROUBLESHOOTING</b> .....	<b>6</b>
<b>10. PREVENTIVE MAINTENANCE</b> .....	<b>6</b>
<b>11. SERVICE INFORMATION</b> .....	<b>7</b>
11.1 INTRODUCTION.....	7
11.2 PARTS LIST.....	8
11.3 SERVICE PROCEDURES.....	17
11.4 TECHNICIAN TROUBLESHOOTING.....	22
11.5 PROBE RESISTENCE CHART.....	24
11.6 WIRING DIAGRAMS.....	25
11.7 SCHEMATIC.....	27

Frymaster L.L.C., 8700 Line Avenue 71106, P.O. Box 51000, Shreveport, Louisiana 71135-1000  
TEL 318-865-1711 FAX (Parts) 318-219-7140 (Tech Support) 318-219-7135

## **FOR YOUR SAFETY:**

**DO NOT STORE OR USE GASOLINE OR OTHER FLAMMABLE VAPORS AND LIQUIDS IN THE VICINITY OF THIS OR ANY OTHER APPLIANCE.**

**DO NOT OPERATE OR SERVICE THE VERTICAL TOASTER WITHOUT FIRST READING THIS MANUAL**

**DO NOT OPERATE THE VERTICAL TOASTER UNLESS IT HAS BEEN PROPERLY INSTALLED AND CHECKED.**

**DO NOT OPERATE THE VERTICAL TOASTER UNLESS ALL COVERS AND ACCESS PANELS ARE IN PLACE AND PROPERLY SECURED.**

**DO NOT ATTEMPT TO REPAIR OR REPLACE ANY COMPONENT OF THE VERTICAL TOASTER UNLESS ALL POWER TO THE UNIT HAS BEEN DISCONNECTED.**

**USE CAUTION WHEN SETTING UP, OPERATING, OR CLEANING THE VERTICAL TOASTER TO AVOID CONTACT WITH HEATED SURFACES.**

**HAZARD COMMUNICATION STANDARD (HCS) – THE PROCEDURES IN THIS MANUAL INCLUDE THE USE OF CHEMICAL PRODUCTS. THESE CHEMICAL PRODUCTS WILL BE PRINTED IN BOLD FACE, FOLLOWED BY THE ABBREVIATION (HCS) IN THE TEXT PORTION OF THE PROCEDURE. SEE THE HAZARD COMMUNICATION STANDARD (HCS) MANUAL FOR THE APPROPRIATE MATERIAL SAFETY DATA SHEET(S) (MSDS).**

# 1. WARRANTY STATEMENT

The Frymaster Corporation makes the following limited warranties to the original purchaser only for this equipment and replacement parts:

## 1.1 WARRANTY PROVISIONS – VERTICAL TOASTER

- A. The Frymaster Corporation warrants all components against defects in material and workmanship for a period of 1 year.
- B. All parts, with the exception of belts, are warranted for 1 year after installation date of toaster. (Belts are consumable items.)
- C. If any parts become defective during the first year after installation date, Frymaster will also pay straight-time labor costs to replace the part, plus up to 100 miles/160 km of travel (50 miles/80 km each way).

## 1.2 PARTS RETURN

All defective in-warranty parts must be returned to a Frymaster Factory Authorized Service Center within 60 days for credit. After 60 days, no credit will be allowed.

## 1.3 WARRANTY EXCLUSIONS

This warranty does not cover equipment that has been damaged due to misuse, abuse, alteration, or accident such as:

- improper or unauthorized repair;
- failure to follow proper installation instructions and/or scheduled maintenance procedures as prescribed in your MRC cards;
- improper maintenance;
- damage in shipment;
- abnormal use;
- removal, alteration, or obliteration of the rating plate.

This warranty also does not cover:

- transportation or travel over 100 miles/160 km (50 miles/80 km each way), or travel time over two (2) hours.
- overtime or holiday charges;
- consequential damages (the cost of repairing or replacing other property which is damaged); loss of time, profits, use or any other incidental damages of any kind.

There are no implied warranties of merchantability or fitness for any particular use or purpose.

For international warranty, the above procedures apply, except that the customer is responsible for freight and duty charges.

### **NOTICE**

**IF, DURING THE WARRANTY PERIOD, THE CUSTOMER USES A PART FOR THIS ENODIS EQUIPMENT OTHER THAN AN UNMODIFIED NEW OR RECYCLED PART PURCHASED DIRECTLY FROM FRYMASTER/DEAN, OR ANY OF ITS AUTHORIZED SERVICE CENTERS, AND/OR THE PART BEING USED IS MODIFIED FROM ITS ORIGINAL CONFIGURATION, THIS WARRANTY WILL BE VOID. FURTHER, FRYMASTER/DEAN AND ITS AFFILIATES WILL NOT BE LIABLE FOR ANY CLAIMS, DAMAGES OR EXPENSES INCURRED BY THE CUSTOMER WHICH ARISE DIRECTLY OR INDIRECTLY, IN WHOLE OR IN PART, DUE TO THE INSTALLATION OF ANY MODIFIED PART AND/OR PART RECEIVED FROM AN UNAUTHORIZED SERVICE CENTER.**

## 2. PARTS ORDERING AND SERVICE INFORMATION

Parts orders may be placed directly with your local Frymaster Factory Authorized Service Center (FASC)/Distributor. A list of Frymaster FASCs was included with the unit when shipped from the factory. If you do not have access to this list, contact the Frymaster Service Department at 1-800-24-FRYER or 1-318-865-1711.

To speed up your order, the following information is required:

Model Number \_\_\_\_\_  
Serial Number \_\_\_\_\_  
Voltage \_\_\_\_\_  
Part Number \_\_\_\_\_  
Quantity Needed \_\_\_\_\_

Service may be obtained by contacting your local FASC or Distributor. Service information may be obtained by calling the Frymaster Service Department. The following information will be needed in order to assist you quickly and efficiently.

Model Number \_\_\_\_\_  
Serial Number \_\_\_\_\_  
Nature of Problem \_\_\_\_\_  
\_\_\_\_\_  
\_\_\_\_\_  
\_\_\_\_\_

Also include any other information which may be helpful in solving your service problem.

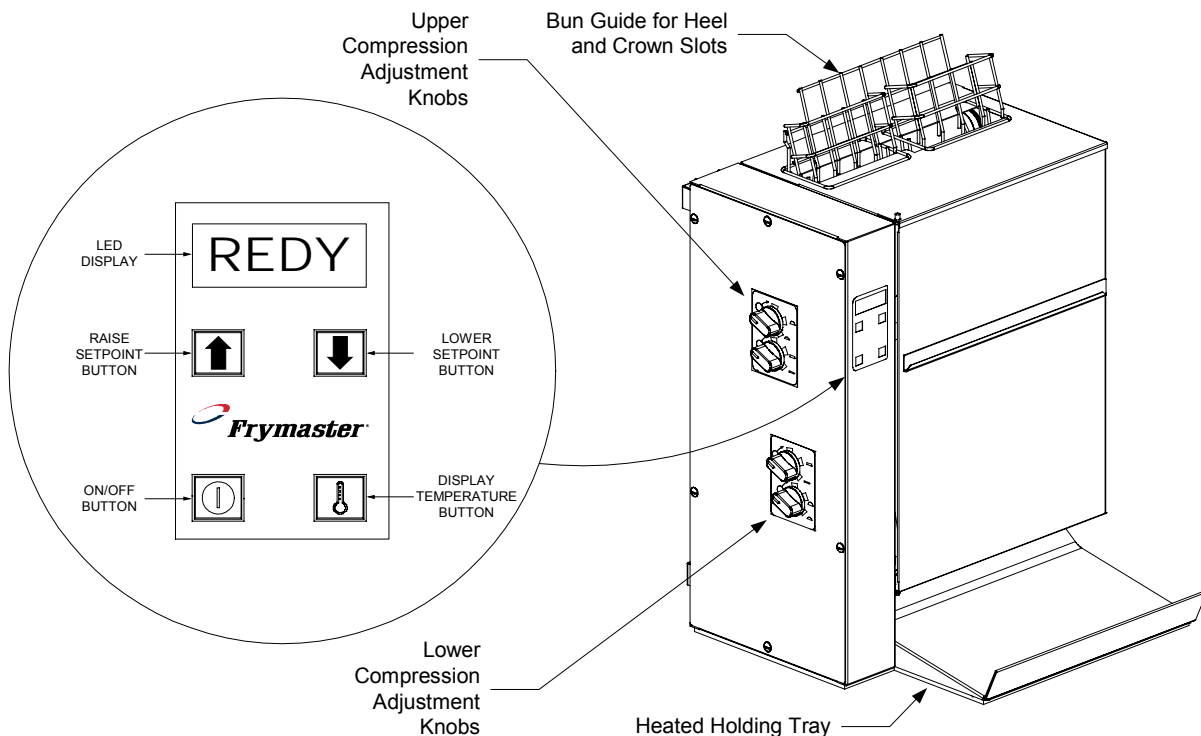

### 3. VERTICAL TOASTER OPERATIONAL DESCRIPTION

The Vertical Toaster is designed to produce fresh, uniformly toasted buns on an "as needed" basis. The countertop-mounted unit consists of a cabinet, a computer, a heating element and a pair of conveyor assemblies.

When the unit is turned on, an electrical heating element (called a *platen*) is energized. The platen heats up to a programmed temperature referred to as the *setpoint*. At the same time, both conveyor assemblies are activated. When a bun is placed into one of the slots at the top of the cabinet, the conveyor belts gently carry it through the unit, with the cut face of the bun passing over the heated platen. As the bun passes over the platen, it is toasted. At the end of the process, the bun is deposited onto a heated holding tray that keeps it warm until it is used in a sandwich.

The computer allows the operator to adjust the setpoint to obtain desired toasting characteristics. Compression adjustment knobs also allow the operator to adjust the compression of heels and crowns as they pass through the toaster.

### 4. INSTALLATION/SETUP

Upon arrival, inspect the toaster for concealed damage. Immediately report any damage to the delivering freight company. Claims must be filed within 15 days after receipt of the unit.

#### **Power Requirements:**

ALL ELECTRICALLY OPERATED APPLIANCES MUST BE ELECTRICALLY GROUNDED IN ACCORDANCE WITH LOCAL CODES, OR IN THE ABSENCE OF LOCAL CODES, WITH THE NATIONAL ELECTRICAL CODE (ANSI/NFPA NO. 70-1990) OR THE CORRESPONDING NATIONAL CODE OF THE COUNTRY IN WHICH INSTALLED.

THIS APPLIANCE IS EQUIPPED WITH A GROUNDING PLUG FOR YOUR PROTECTION AGAINST SHOCK HAZARD AND MUST BE PLUGGED INTO A PROPERLY GROUNDED RECEPTACLE. DO NOT CUT OR REMOVE THE GROUNDING PRONG FROM THIS PLUG!

- Voltage: 208VAC or 240VAC depending on model ordered
- Frequency: 60 Hz (non-CE )or 50 Hz (CE and Australian models)
- Phase: Single
- Service: 20 Amp

#### **Setup:**

Setup of the toaster consists of unpacking the unit, placing it on a sturdy table or countertop adjacent to a properly grounded AC outlet of appropriate voltage, removing the cardboard packing inserts, installing the bun feeder in the slot on top of the cover, and plugging it in. **NOTE:** The cover must be closed to install the bun feeder, and the bun feeder must be removed to open the cover.



The unit is shipped with a programmed setpoint of 550°F (288°C), upper crown compression knob set to **4**, lower crown compression knob set to **5**, upper heel compression knob set to **D**, and lower compression knob set to **E**. The operator may change these settings to attain desired toasting.

### 5. OPERATION









1. Press the ON/OFF  button. The word **LOW** will appear in the green LED display window. The unit will take about 10 minutes to reach operating temperature, at which time the display will change to **REDY**, indicating the toaster is ready for use.

2. Load buns into the appropriate slots (Heel or Crown) one at a time, with the cut faces toward the rear of the unit. The unit will toast the buns and transfer them to the heated holding tray.
3. Adjust the setpoint and bun compression as necessary to achieve desired toasting.

## 6. VIEWING AND ADJUSTING THE SETPOINT

To view the platen temperature, press the  button once. The temperature in degrees Fahrenheit will appear in the green LED display window. To view the current setpoint, press the  button twice. The setpoint in degrees Fahrenheit will be displayed in the green LED display window. To toggle the display to Celsius, unplug the unit, then press and hold the  button as the unit is plugged back in.

### To change the setpoint:

1. Turn the unit OFF (press the  button). Enter the setpoint programming mode by pressing the , , ,  buttons in that order. The current setpoint will appear in the LED display. To increase the setpoint, press the  button; to decrease it, press the  button.
2. When the desired setpoint is displayed, press the  button once. Press the ON/OFF  button. If the platen is within 20°F (11°C) of the setpoint, the display will show REDY. Otherwise, the display will show LOW or HIGH until the platen is within 20°F (11°C) of the setpoint, at which time the display will change to REDY.

## 7. ADJUSTING BUN COMPRESSION

1. There are two pairs of compression adjustment knobs (one pair numbered 1-5, the other lettered A-E), as shown in the accompanying illustration. Factory settings are circled.

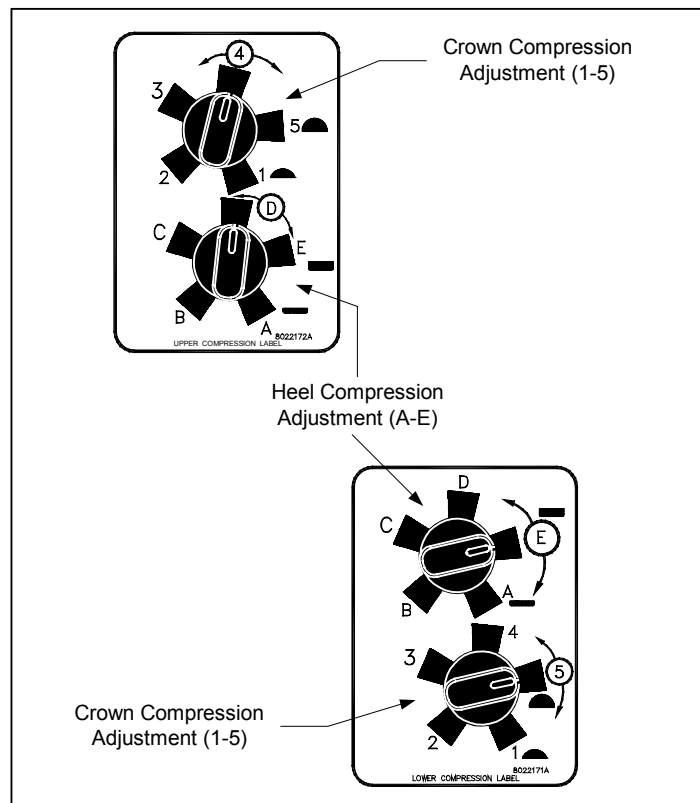

2. Settings A and 1 cause the greatest bun compression (that is, the thinnest bun after toasting).

## 8. CHANGING BELTS

1. Turn the unit off (press the ON/OFF  button) then unplug it. If the unit has been in operation, allow it to cool for about 1½ hours. **TIP:** Change belts in the morning, prior to turning the toaster on.
2. **Remove the bun feeder**, and then open the cover.
3. Set the bun compression knobs to positions **E** and **5**.
4. Press down on the top roller and move it to the retracted (down) position. (**NOTE:** Each side of the roller must be locked down.)



5. Rotate the tray stabilizer latch upward to unlatch it.

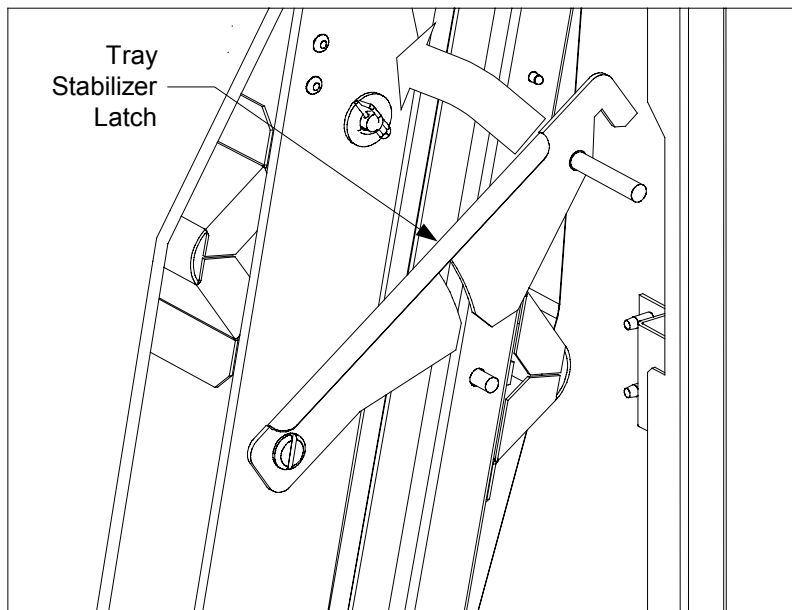

6. Slip the old belt off the rollers and slip the new belt on. When the replacement belt has been properly positioned between the raised edges of its rollers, rotate the tray stabilizer latch to the latched position.
7. Press down on the top roller to unlock it and allow it to extend.
8. Close the cover. Return the bun compression knobs to their previous settings.

## 9. OPERATOR TROUBLESHOOTING

PROBLEM	PROBABLE CAUSES	CORRECTIVE ACTION
PRO1 in LED display.	A. Indicates failure of main platen probe or associated circuitry.	A. Call FASC.
PRO2 in LED display.	A. Indicates failure of tray heater probe or associated circuitry.	A. Call FASC.
Bun conveyors do not start when ON/OFF button is pressed.	A. Cover not properly installed.	A. Make sure cover is correctly positioned so that the cover interlock switch is depressed.
	B. Toaster not plugged in.	B. Plug toaster in.
	C. Store circuit breaker tripped.	C. Reset circuit breaker.
	D. Failed cover interlock switch, failed high limit, failed motor, or failed controller.	D. Call FASC.
Toasting is consistently too dark or too light.	A. Improper setpoint programmed and/or incorrect compression knob setting.	A. If toasting is too dark, lower the setpoint and/or compression setting until desired toasting is achieved.  If toasting is too light, increase setpoint and/or compression setting until desired toasting is achieved.
Buns are too thick or too thin.	A. Compression knobs on an improper setting for desired compression.	A. Adjust the compression knobs to achieve desired compression. Moving them to a lower setting will increase compression. Moving them to a higher setting will decrease compression. Make sure both pairs of knobs are on the same setting.
Buns are toasting inconsistently.	A. Belt slippage.	A. Shut down and clean unit, paying particular attention to grooves in rollers and condition of belts.
	B. Incorrect belt speed, faulty platen heater, or faulty controller.	B. Call FASC.

## 10. PREVENTIVE MAINTENANCE

A separate set of Maintenance Requirement Cards (MRCs) is furnished with this manual. In addition to the checks and services contained in the MRCs, Frymaster recommends that this appliance be inspected by a Frymaster Factory Authorized Service Technician at least annually as follows:

- Inspect all wiring for signs of chafing, kinking, and/or loose connections.
- Verify that all mechanical and electronic components are securely mounted (i.e., screws and nuts and bolts are tight.)
- Verify that idler roller springs are in serviceable condition (i.e., rollers are held securely in the top of the J-slots and belts do not slip).



## 11. SERVICE INFORMATION

### 11.1 INTRODUCTION

Vertical toasters manufactured for use in the European Union (CE) and those manufactured for use elsewhere are identical in most respects, but there are some important differences. The paragraphs that follow summarize the differences and provide a list of the parts that are unique to each model.

The most significant differences are in the electronic components. Units built for the CE and Australian markets have a 50 Hz motor; all others have a 60 Hz motor. Non-CE and CE/Australian units also use different transformers, and CE/Australian units have a line filter built into the electrical power supply system. The line filter and cover are attached to the rear of the cabinet.

Because of the difference in the power cycle frequency (50 Hz vs. 60 Hz), CE and Australian units are equipped with 10-tooth drive pulleys and a 28-Tooth motor pulley. Standard units have 17-tooth drive pulleys and an 18-tooth motor pulley. The different pulleys on the CE and Australian units maintain the correct belt speed even though the RPM of the motor at 50 Hz is slightly slower than that of the motor at 60 Hz.

The table below identifies the components that are unique to each configuration.

Components Unique to CE and Australian Units		Components Unique to Non-CE Units	
P/N	Description	P/N	Description
807-2191	Transformer (208-240V/12V)	807-0979	Transformer (208-240V/12V)
807-0910	Transformer Fuse, 250V/3A	N/A	Not used.
106-0781	Transformer and Bracket Assembly	N/A	Not used.
807-3472	Line Filter	N/A	Not used.
824-0896	Line Filter Cover	N/A	Not used.
106-2143	Tensioner Assembly, Drive Belt	106-2723	Tensioner Assembly, Drive Belt
810-2300	28-Tooth Motor Driven Pulley	810-2565	18-Tooth Motor Driven Pulley
810-2301	10-Tooth Dual Belt Drive Pulley	810-2566	17-Tooth Dual Belt Drive Pulley
810-2332	10-Tooth Toasting Belt Drive Pulley	810-2564	17-Tooth Toasting Belt Drive Pulley

The illustrations in the parts list that follows also identify the CE/Australian and Non-CE components.

# 11.2 PARTS LIST

## CABINETRY

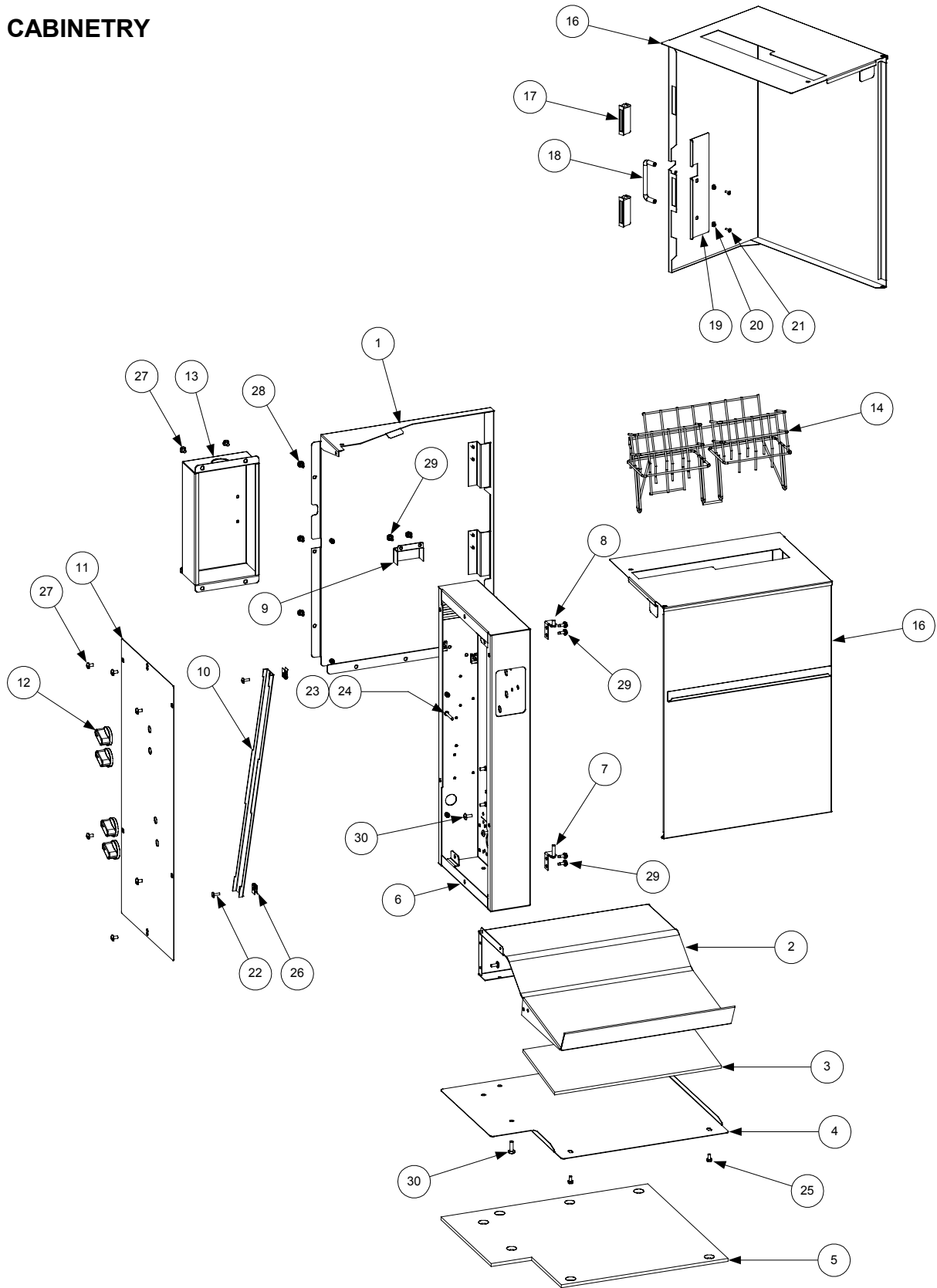

ITEM	PART #	COMPONENT
1	106-2720	Back Cover Assembly
2	824-1117	Tray Assembly, Toast
3	816-0573	Insulation, Toast Tray
4	200-4270	Bottom, Toaster
5	816-0589	Seal, Toaster Base
6	823-3988	Housing, Component
7	823-2940	Bracket, Lower Hinge
8	823-2941	Bracket, Upper Hinge
9	210-3434	Cover, Air Inlet
10	200-2877	Brace, Component Housing
11	210-2876	Cover, Component Housing
12	810-2331	Knob, Compression Adjustment
13	824-0896	Cover, Line Filter (used on CE and Australian units only)
14	810-2278	Guide, Bread (Wireform Feeder)
15	106-2158	Cover Assembly, Toaster (includes Items 16-21)
16	823-3656	Cover (does not include Items 17-21)
17	810-0066	Magnet
18	810-1683	Handle, Cover
19	910-9458	Reinforcement, Cover Side
20	809-0184	Washer, #10 Lock
21	809-0107	Screw, 8-32 x $\frac{3}{8}$ -inch Slotted Round Head
22	809-0104	Screw, 8-32 x $\frac{1}{2}$ -inch Slotted Truss Head
23	809-0112	Screw, 8-32 x 1 $\frac{1}{4}$ -inch Slotted Truss Head
24	809-0247	Nut, 8-32 Hex
25	809-0434	Screw, #10 x $\frac{3}{8}$ -inch Hex Washer Head
26	809-0448	Clip, Tinnerman
27	826-1330	Screw, 10-32 x $\frac{3}{8}$ -inch Slotted Truss Head (Pkg. of 25)
28	826-1374	Screw, #10 x $\frac{1}{2}$ -inch Hex Head (Pkg. of 25)
29	826-1379	Screw, #10 x $\frac{1}{2}$ -inch Philips Truss Head (Pkg. of 10)
30	826-1389	Screw, $\frac{1}{4}$ -20 x $\frac{3}{4}$ -inch Hex Head (Pkg. of 10)
*	810-1712	Clip, Adhesive-backed Wire Routing

\* Not illustrated

# CONVEYOR ASSEMBLY, DUAL BELT

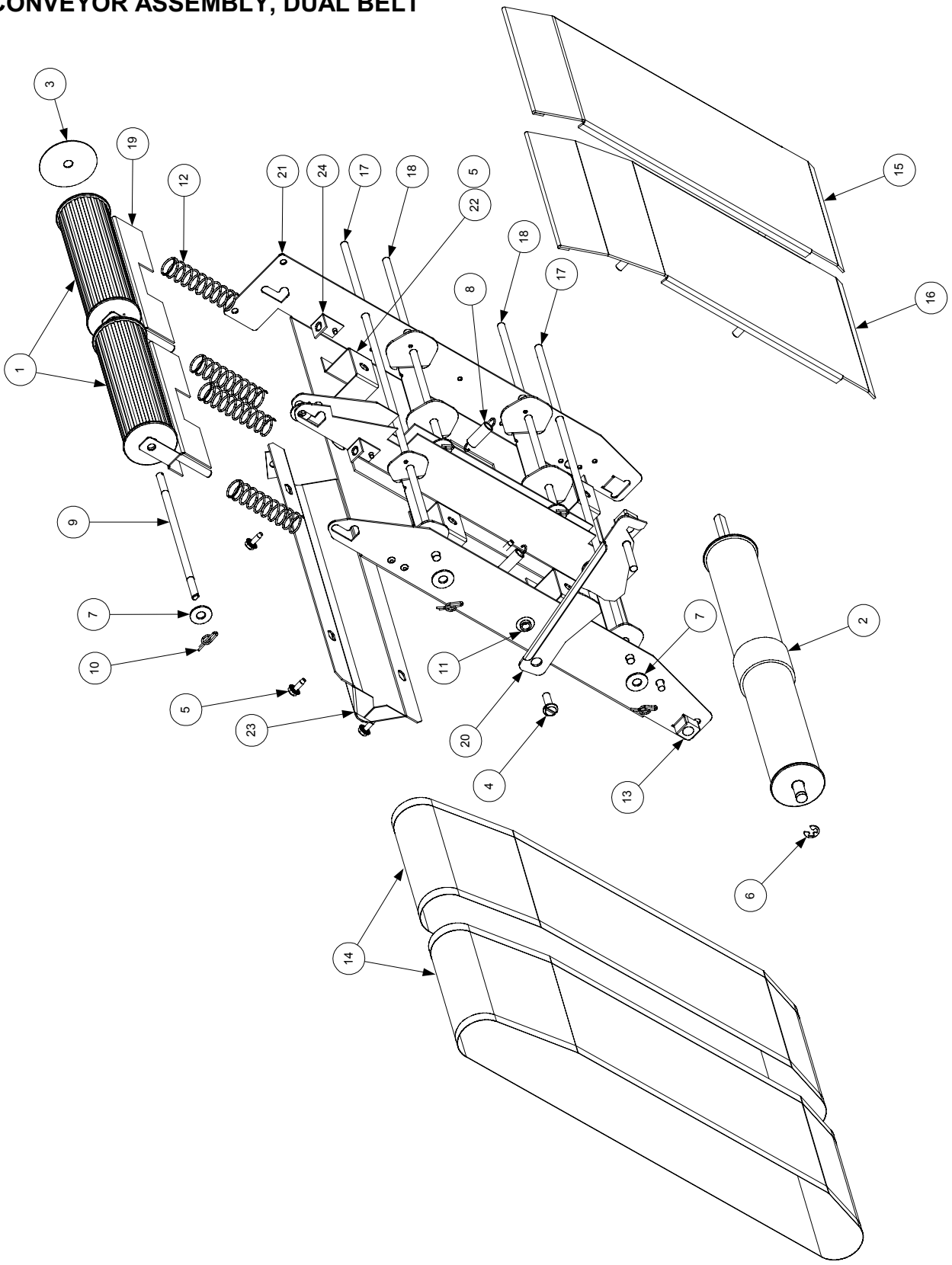

<b>ITEM</b>	<b>PART #</b>	<b>COMPONENT</b>
1	806-9200	Roller Assembly, Dual Belt Idler
2	806-9318	Roller Assembly, Dual Belt Drive
3	810-2303	Washer, Teflon Crumb
4	809-0132	Screw, ¼-20 x ¾-inch Slotted Pan Head
5	826-1374	Screw, #10 x ½-inch Hex Head (Pkg. of 25)
6	809-0647	E-Ring
7	809-0745	Washer, ¼-inch Flat
8	810-1672	Spring, Compression Plate
9	810-1718	Shaft, Short Dual Belt Roller
10	810-1776	Pin, VT Cotter
11	810-1802	Bushing, Tray Stabilizer Latch Support
12	810-1818	Spring, 3.00-inch Long, 4.6 Lbs./Inch
13	810-2305	Bushing
14	816-0389	Belt, Dual Conveyor
15	823-2719	Plate Assembly, VT Right Pressure
16	823-3578	Plate Assembly, VT Left Pressure
17	823-2722	Cam Assembly, VT Long
18	823-2723	Cam Assembly, VT Short
19	823-2798	Cover Assembly, VT Spring
20	823-2838	Latch Assembly, VT Tray
21	823-3989	Tray Assembly, Dual Belt
22	900-8155	Bracket, Guide Rod
23	910-8254	Brace, Dual Belt Tray
24	910-8512	Bracket, Spring Guide Receiver
25	210-4245	Bracket, Left Center Support
26	210-4246	Bracket, Right Center Support

# CONVEYOR ASSEMBLY, TOASTING

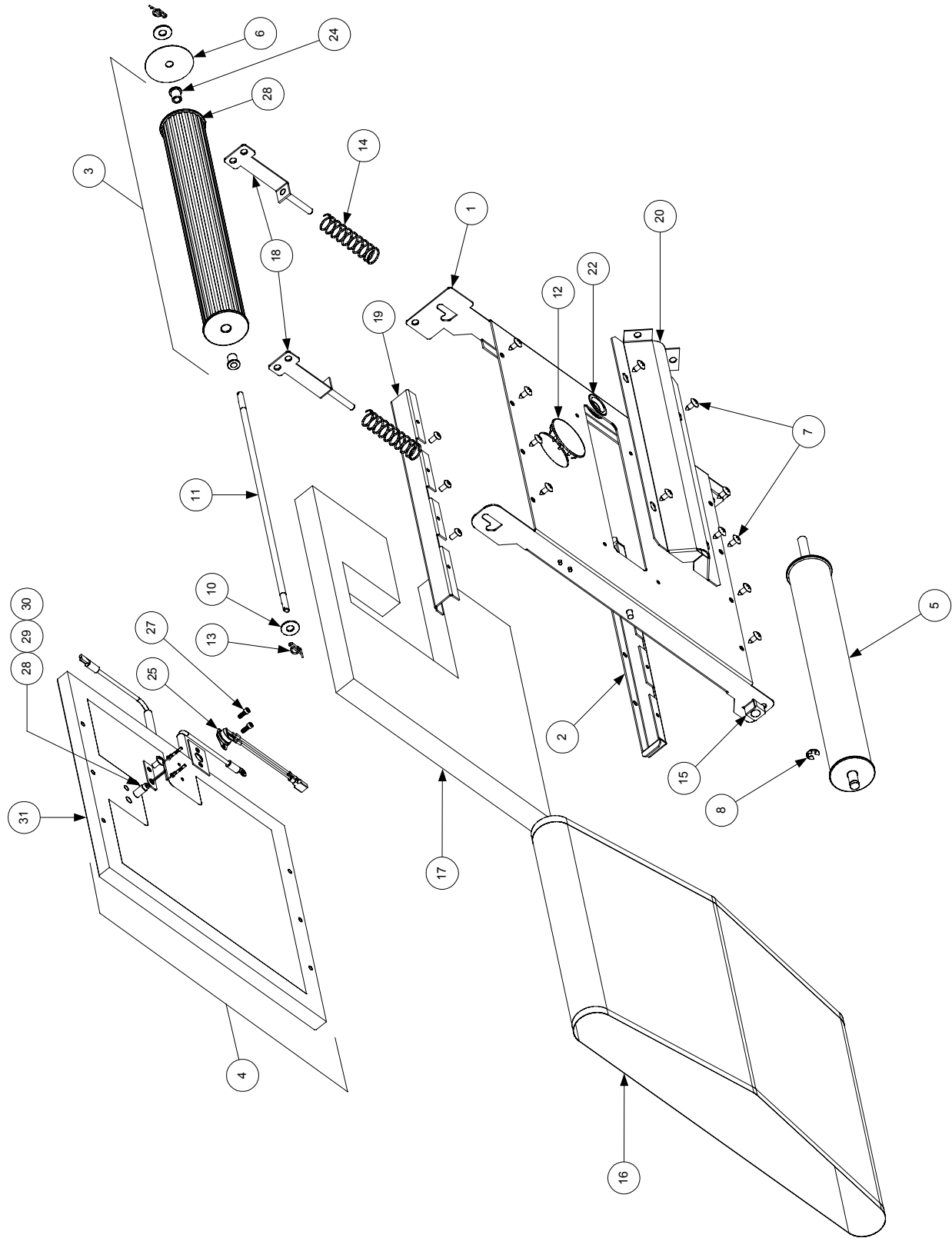

ITEM	PART #	COMPONENT
1	106-2123	Tray with Grommet, VT Platen
2	210-0318	Crumb Shield, Toasting Conveyor
3	806-9195	Roller, VT Toasting Belt Idler
4	806-9196	Platen Assembly, VT
5	810-2017	Roller, VT Toasting Belt Drive
6	810-2103	Washer, Teflon Crumb
7	809-0266	Screw, #10 x 1/2-inch Philips Truss Head
8	809-0647	E-Ring
9	809-0650	Screw, 10-32 x 3/8-inch Button Socket Head
10	809-0745	Washer, 1/4-inch Flat
11	810-1721	Shaft, Long Roller
12	810-1736	Plug, 1.75-inch Stainless Button
13	810-1776	Pin, VT Cotter
14	810-1818	Spring, 3-inches Long, 4.6 Lbs./Inch
15	810-2305	Bushing, Roller
16	816-0379	Belt, Toasting
17	816-0403	Insulation, Platen
18	823-2726	Slide Assembly, Belt Tension
19	910-8246	Guide, Crumb Shield
20	910-8254	Brace, VT Platen Tray
21*	910-8512	Bracket, Slide Assembly Receiver
22	810-1722	Grommet, .5-inch I.D. x 1.05-inch O.D. (Integral component of Item 1)
23	810-2013	Roller, VT Drive (Integral component of Item 3)
24	810-1810	Bushing, Teflon (Integral component of Item 3)
25	807-3037	Thermostat, High-Limit (Integral component of Item 4)
26	910-8637	Spacer, High-Limit Thermostat (Integral component of Item 4)
27	809-0729	Capscrew, 6-32 x 1/4-inch Socket Head (Integral component of Item 4)
28	807-3247	Probe, Heater (Integral component of Item 4)
29	910-8757	Retainer, Heater Probe (Integral component of Item 4)
30	826-1330	Screw, 10-32 x 3/8-inch Slotted Truss Head (Integral component of Item 4)
31	810-1658	Platen, 5000W (Integral component of Item 4)

\* Obscured by Item 1. See Item 24 on Page 10 for illustration.

# ELECTRONIC COMPONENTS

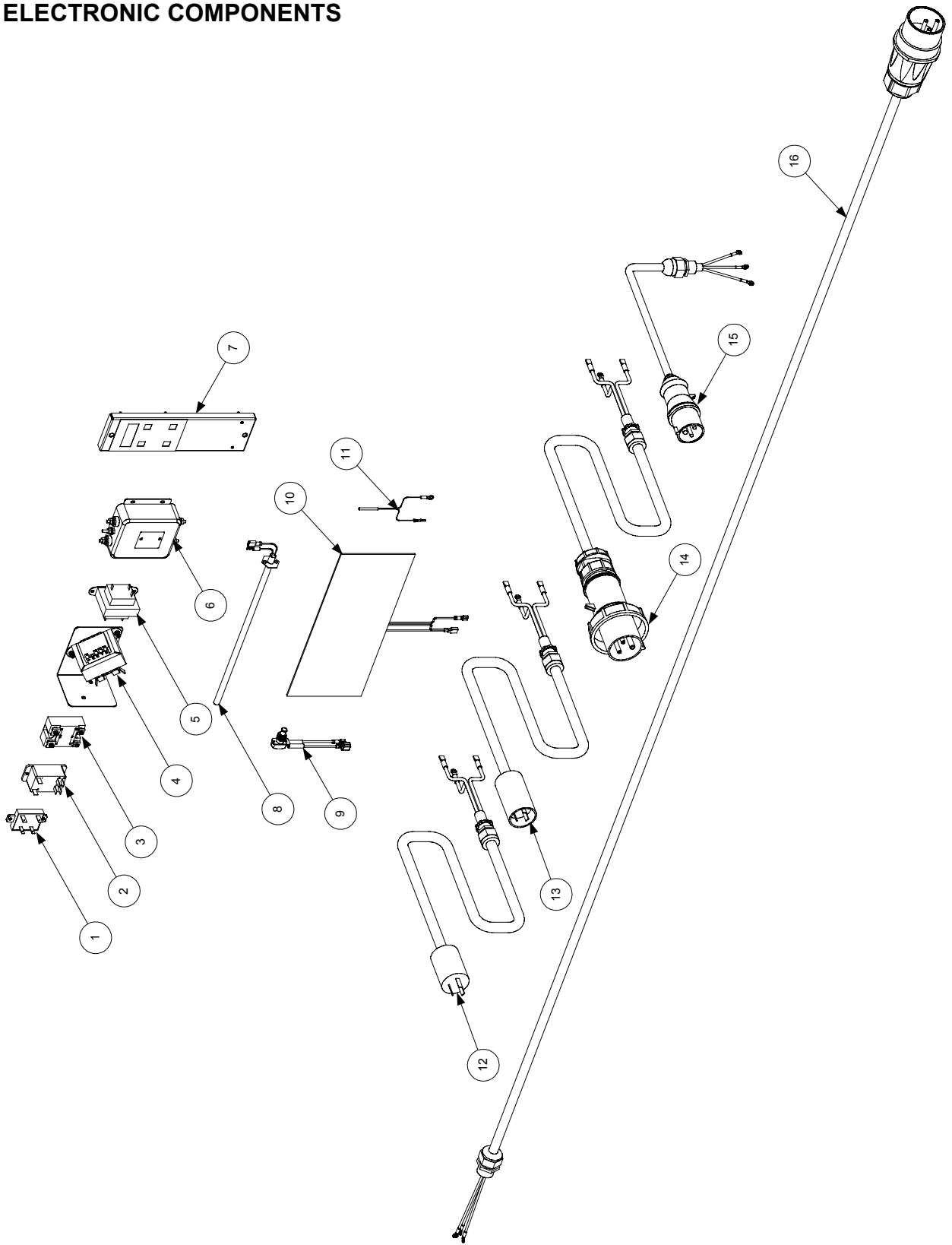



ITEM	PART #	COMPONENT
1	807-3213	Relay, Solid State 5A 3/16 Control Terminals
2	807-3021	Relay, 30A 12VDC DPST NO
3	826-1562	Relay, Solid State 40A 280V SPST NO
4	106-0781	Transformer and Bracket Assembly, CE and Australian
*	807-0910	Fuse, 250V 3A (fuse for CE/Australian transformer)
5	807-0979	Transformer, 208-240VAC/12VAC, 50/60 Hz, 43VA
7	806-9296	Computer Assembly, VT
8	807-3196	Heater, 240V 165W Cartridge
9	807-3064	Switch, Cover Interlock
10	806-9579	Heater Assembly, VT Tray
11	807-3132	Probe, VT Tray Heater
*	816-0573	Insulation, VT Tray Heater (See Pages 8 and 21 for illustrations.)
*	811-0746	Tape, Aluminum (secures probe, tray heater, and insulation to tray)
12	807-3243	Cordset, Standard Twist-Lock
13	807-3198	Cordset, Hooded Twist-Lock
14	807-3242	Cordset, Pin and Sleeve
15	807-3529	Cordset, CE VT
16	807-3850	Cordset, Australian VT

\*Not illustrated.

# MOTOR, DRIVE TRAIN AND FAN COMPONENTS

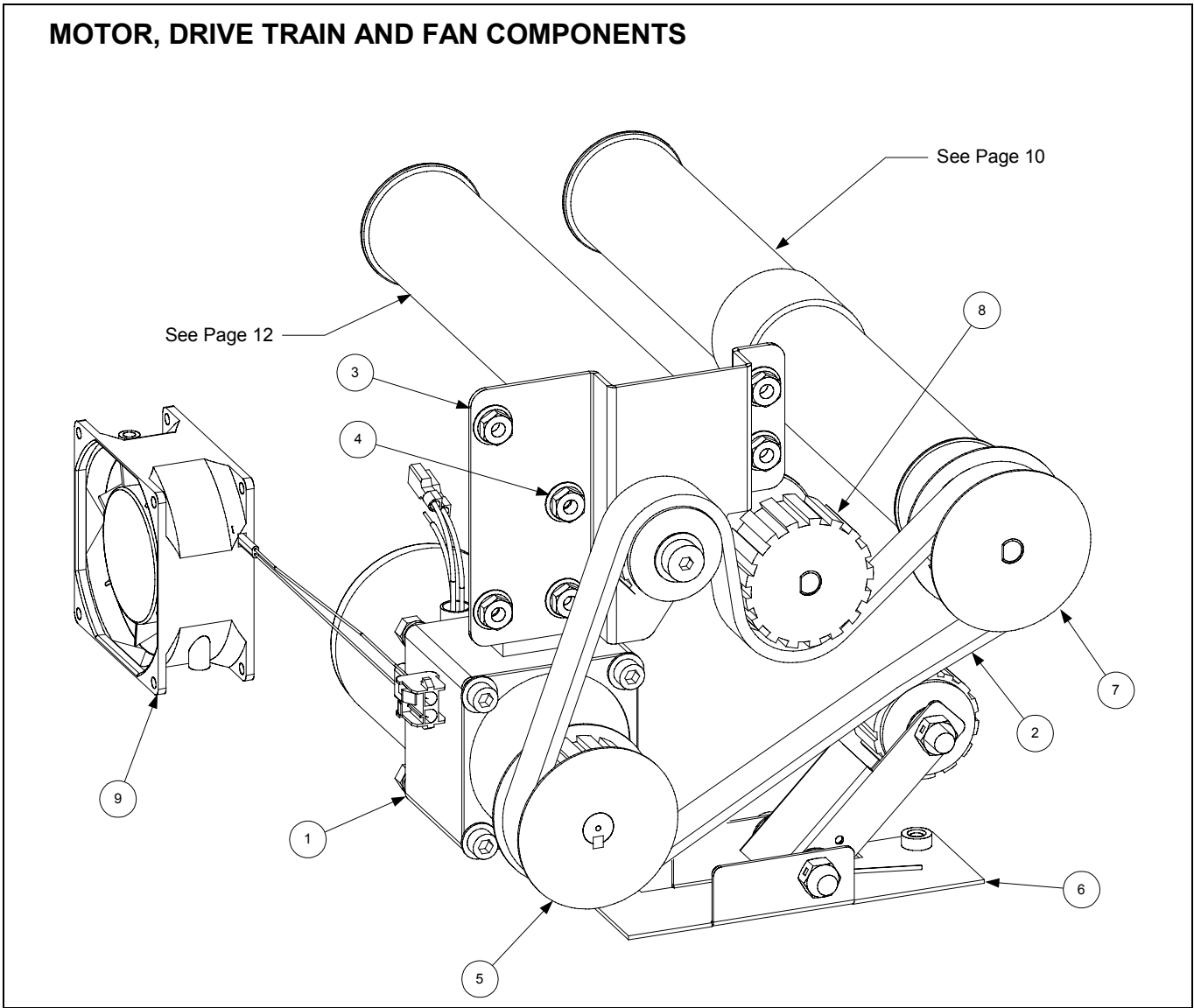

ITEM	PART #	COMPONENT
1		Motor Assembly, 50/60 Hz
	106-3052	200-208V VT Drive
	106-2841	220-250V VT Drive
2	810-2302	Drive Belt
3	106-2128	Bracket Assembly, VT Idler Pulley
4	826-1368	Nut, 1/4-20 Serrated Flange (Pkg. of 10)
5		Pulley, Motor Driven
	810-2565	18-Tooth (Non-CE)
	810-2300	28-Tooth (CE and Australian)
6		Tensioner Assembly, Drive Belt
	106-2723	Non-CE
	106-2143	CE and Australian
7		Pulley, Dual Belt Drive
	810-2566	17-Tooth (Non-CE)
	810-2301	10-Tooth (CE and Australian)
8		Pulley, 17-Tooth Toasting Belt Drive
	810-2564	17-Tooth (Non-CE)
	810-2332	10-Tooth (CE and Australian)
9	106-2703	Fan Assembly, VT Motor Cooling

## 11.3 SERVICE PROCEDURES

**NOTE:** Unless power is necessary for troubleshooting, turn the unit off and unplug it whenever performing service on this equipment.

### Accessing the Electronics

1. Pull the bun compression knobs off their shafts.
2. Remove the screws around the edge of the component housing cover and remove the cover.

### Accessing the Drive Motor, Tray Heater, and Auxiliary Transformer

Carefully lay the unit on its back and remove the seven screws that secure the bottom cover in place.

### Removing the Conveyor Assemblies

1. Turn off and unplug the unit.
2. Remove the bun feeder then remove the cover by lifting it straight up until it is clear of its hinge pins.
3. Rotate the bun compression knobs to positions **5** and **E**.
4. Press down on the top roller(s) of the conveyor assembly to be removed to lock it (them) in the down position.
5. Rotate the tray stabilizer latch upward, then remove the belt(s). Return the tray stabilizer latch to the latched position.
6. Pull the bun compression knobs from their shafts.
7. Remove the screws around the edge of the component housing cover and remove the cover.
8. Remove the diagonal brace.
9. Release the tension on the drive belt by pressing down on the belt tensioner arm and remove the belt from the pulleys.
10. **To remove the dual-belt conveyor assembly:**  
(See illustration on following page.)
  - a. Loosen the setscrew in the forward-most drive pulley and remove the pulley.
  - b. Remove the cartridge heater, marking the leads to facilitate reconnection.
  - c. Remove the four hex-head screws and two flange nuts that secure the conveyor assembly to the component housing from the inside.
  - d. Rotate the tray stabilizer latch upward and, while supporting the conveyor assembly, remove the two hex-head screws securing the top of the conveyor assembly from the outside (conveyor side) of the component housing and carefully pull the conveyor assembly away from the housing.
  - e. Reinstall the conveyor assembly by reversing the steps performed, being sure to reattach the ground wire with the top hex head screw.

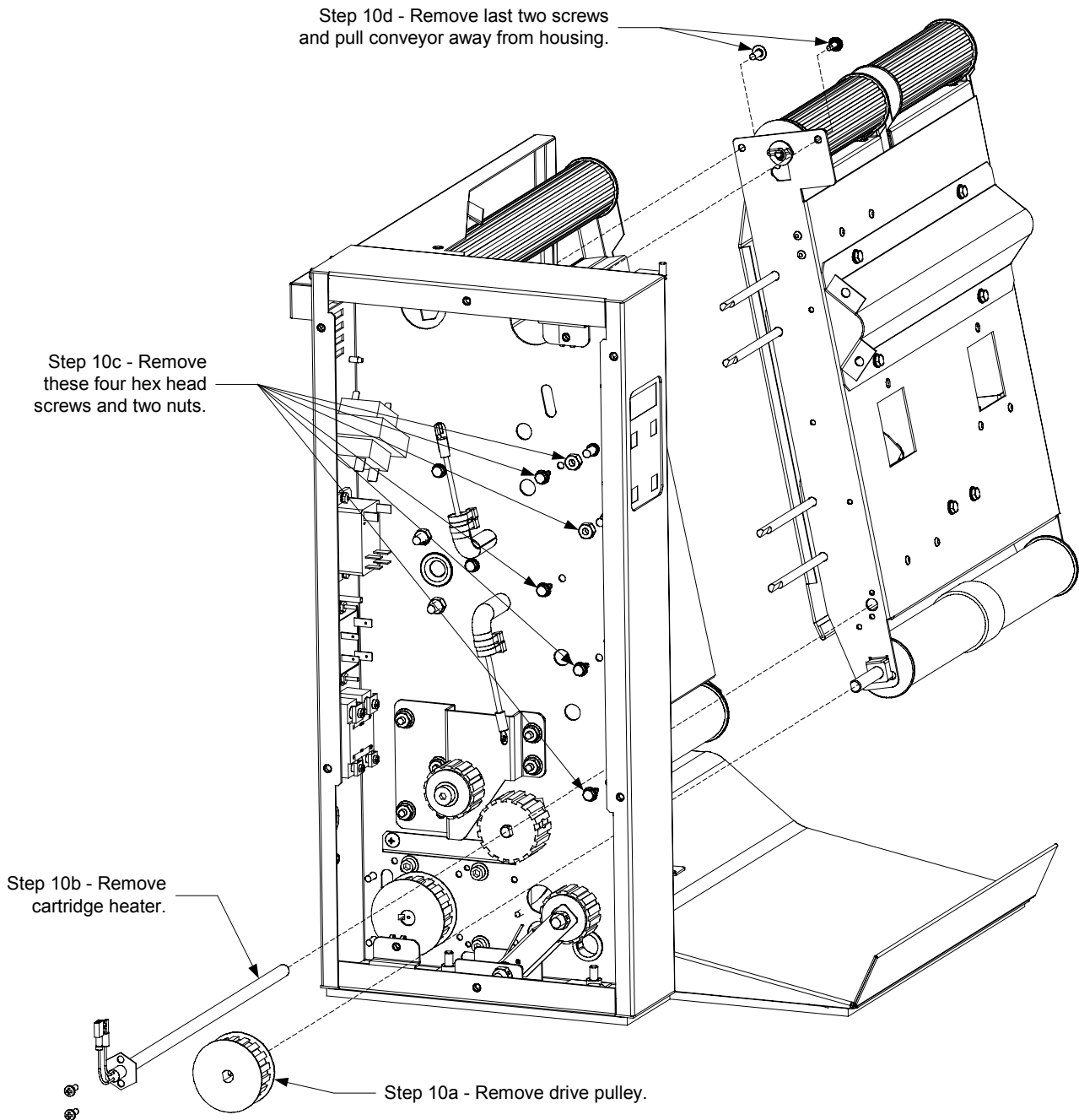

**11. To remove the toasting conveyor assembly:**

(See illustration on following page.)

- a. Detach the platen and probe wiring from the relay, high-limit, and 9-pin connector.
- b. Loosen the setscrew in the second drive pulley from the front and remove the pulley.
- c. Remove the five flange nuts that secure the idler assembly to the housing and remove the idler assembly.
- d. Remove the two hex head screws shown in Step 11d of the illustration on the following page.

- e. Rotate the tray stabilizer latch upward and, while supporting the conveyor assembly, remove the hex-head screw securing the top of the assembly from the outside (conveyor side) of the component housing and carefully pull the assembly away from the housing.

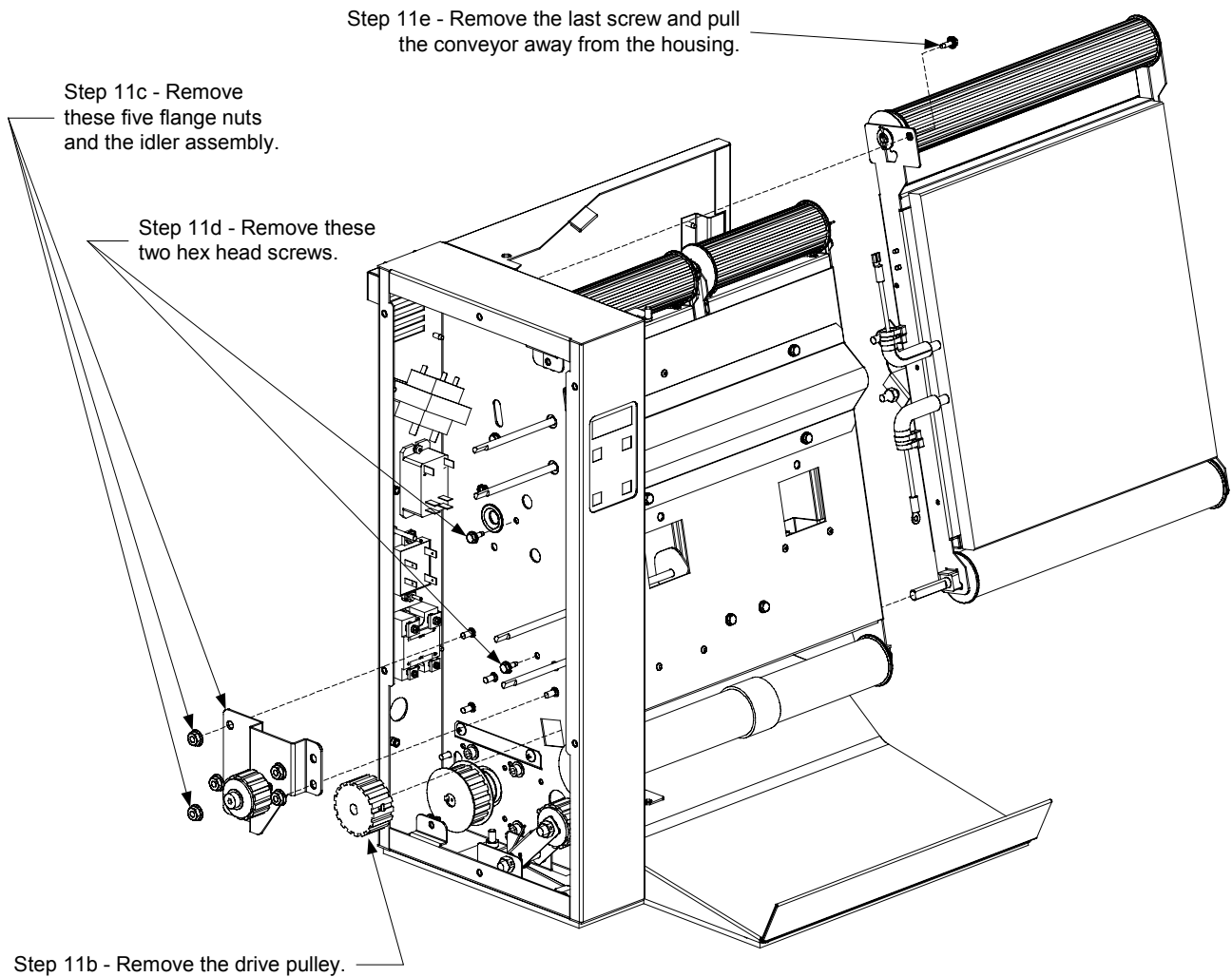

- f. Reinstall the conveyor assembly by reversing the steps performed, being sure to reattach the two ground wires with the lower of the two hex head screws removed in Step 11d.

### Replacing the High-Limit Thermostat or Heater Probe

(See illustration on following page.)

1. Turn off and unplug the unit, and remove toasting conveyor in accordance with the instructions on Pages 18-19.
2. **To replace the high-limit thermostat**, remove the platen tray brace to expose the thermostat and remove the screws securing it in place.
3. **To replace the heater probe**, remove the plug over the probe to expose the component. Remove the screw securing the probe retainer and remove the probe.

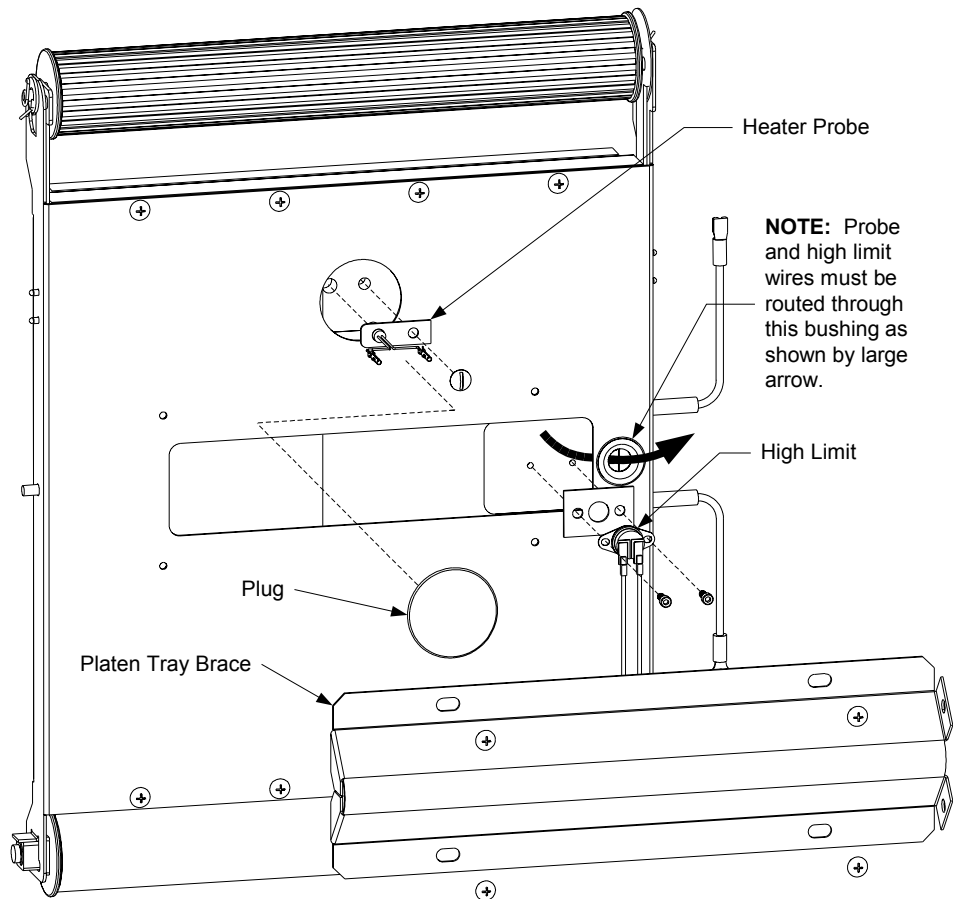

4. Replace the failed component, being sure to route the component wires through the bushing as shown in the illustration above. Reassemble by reversing the steps performed and reconnect the wiring in accordance with the wiring diagram on the inside of the component housing cover.

### Replacing the Drive Motor, Auxiliary Transformer, Tray Heater or Tray Heater Probe

1. Turn off and unplug the unit.
2. Pull the bun compression knobs from their shafts.
3. Remove the screws around the edge of the component housing cover.
4. Disconnect the failed component's wiring, then carefully lay the unit on its back.
5. Remove the screws that secure the bottom cover in place and remove the cover. **NOTE:** The two cap screws that pass through the bottom of the component housing also hold the belt tensioner assembly in place.
6. **To replace the drive motor**, remove the screws that secure the diagonal brace to the component housing. Remove the drive belt. Loosen the setscrew securing the motor pulley to the motor shaft and remove the pulley. Hold the replacement motor next to the failed motor and transfer the wiring connections to the replacement. Remove the four screws that secure the motor to the cabinet and install the replacement.
7. **To replace the auxiliary transformer** (present only in 200V and 208V units), hold the replacement next to the failed transformer and, one at a time, disconnect the wires from the failed transformer and connect them to the replacement. When all wiring has been transferred, remove the screws

and nuts that secure the transformer to the back wall of the motor compartment and install the replacement.

8. **To replace the probe**, use a sharp knife to cut the aluminum tape that secures the foil-backed insulation to the bottom of the tray and remove the insulation. Cut the aluminum tape that secures the heater to the tray and peel back the heater to expose and remove the probe. **To replace the tray heater**, peel it completely off.

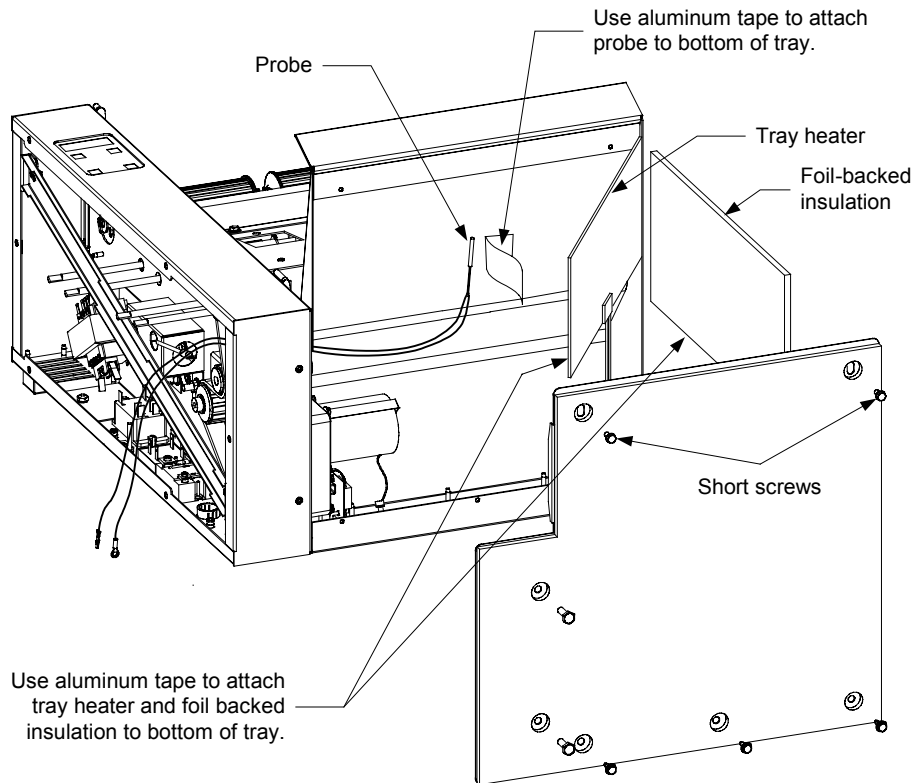

9. Reverse the steps performed to reassemble unit.

### Replacing the Dual Belt Conveyor Cartridge Heater

1. Turn off and unplug the unit.
2. Pull the bun compression knobs off their shafts.
3. Remove the screws in the edge of the component housing cover.
4. Disconnect the heater leads. Remove the hex-head screws securing the heater in place and remove the heater (see illustration on Page 18).
5. Reverse steps 1-4 to reassemble the unit.

### Replacing the Transformer or Relays

1. Turn off and unplug the unit.
2. Pull the bun compression knobs from their shafts.
3. Remove the screws in the edge of the component housing cover.
4. Hold the replacement component next to the component to be replaced and, one at a time, disconnect the wires from the failed component and connect them to the replacement component.

5. Remove the screws and/or nuts securing the failed component to the component housing and install the replacement.
6. Reverse steps 1-3 to reassemble the unit.

## 11.4 TECHNICIAN TROUBLESHOOTING

PROBLEM	PROBABLE CAUSES	CORRECTIVE ACTION
Display remains blank when unit turned on.	A. Failed transformer.	A. Check for line voltage on the primary (line) side of transformer and 12VAC on secondary (load) side of transformer. If line voltage is present but secondary voltage is not 12VAC, the transformer has failed.
	B. Failed computer.	B. Check continuity between right terminal of secondary (load) side of transformer and Pin 9 of the 9-pin connector when the cover interlock switch is closed. If resistance is zero, replace the computer.
	C. Failed cover interlock switch or failed high limit.	C. Check continuity between switch terminals when the switch is closed. If resistance is infinite, replace switch. If resistance is zero, replace high limit.
Computer display is on, but motor is not running	A. Failed motor.	A. If platen is heating, replace motor.
	B. Broken/loose wire between computer and latch relay or failed latch relay.	B. Check for 12VDC on Pins 6 & 7 of computer. If present and wiring is intact, replace latch relay. If not present, replace computer.
Motor is running at wrong speed (i.e. average time for three individual buns to pass through toaster is <b>NOT</b> between 15 and 18 seconds).	A. Toaster improperly configured for power supply.	A. Check data plate for voltage rating, and verify that power supply and toaster match.
Platen heats, but unit does not reach setpoint.	A. Improper power-supply.	A. Verify that the power supply is 20 amp single-phase 200, 208 or 240VAC (depending upon model).
	B. Failed temperature probe.	B. Use a temperature-measuring device to determine actual platen temperature. If measured temperature is within 10 degrees of the temperature displayed on the computer and the probe resistance at pins 3 and 5 of the 9-pin connector <b>does not</b> correspond to the appropriate value in the probe resistance chart on Pages 24 and 25, replace the probe.
	C. Failed computer.	C. Use a temperature-measuring device to determine actual platen temperature. If measured temperature is within 10 degrees of the temperature displayed on the computer and probe resistance at pins 3 and 5 of the 9-pin connector corresponds to the value in the probe resistance chart on Pages 24 and 25, replace the computer.



PROBLEM	PROBABLE CAUSES	CORRECTIVE ACTION
Platen does not heat, but computer display is on.	A. Failed computer.	A. Check for 12VDC on computer pins 6 & 7. If NOT present AND motor is running, replace computer. Check for 5VDC on terminals 3 & 4 of main heater relay and pins 1 and 6 of computer. If NOT present at either point AND motor is running, replace computer.
	B. Broken/loose wire between computer and latch relay, or failed latch relay.	B. Check for 12VDC on computer pins 6 & 7. If present and wiring is intact, replace latch relay.
	C. Failed main heater probe.	C. Determine temperature of platen then measure main heater probe resistance at pins 3 & 5 of 9-pin connector. If the probe resistance is NOT approximately equal to the corresponding resistance in the chart on Pages 24 and 25, replace the probe.
	D. Broken/loose wire between computer and main heater relay, or failed main heater relay.	D. Check for 5VDC on terminals 3 & 4 of main heater relay AND on computer pins 1 & 6. If present on pins 1 & 6, but NOT on terminals 3 & 4, and wiring is intact, replace the main heater relay.
	E. Failed platen.	E. Check for 5VDC on terminals 3 & 4 of main heater relay and for line voltage on terminal 2 of main heater relay and terminal 4 of latch relay. If expected voltage is present at all three points, replace the platen.
Tray heater does not heat, but computer display is on.	A. Failed computer.	A. Check for 12VDC on computer pins 6 & 7. If NOT present AND motor is running, replace computer. Check for 5VDC on terminals 3 & 4 of main heater relay and pins 2 and 6 of computer. If NOT present at either point AND motor is running, replace computer.
	B. Broken/loose wire between computer and latch relay, or failed latch relay.	B. Check for 12VDC on computer pins 6 & 7. If present and wiring is intact, replace latch relay.
	C. Failed tray heater probe.	C. Determine temperature of tray heater then measure tray heater probe resistance at pin 4 of 9-pin connector and ground. If the probe resistance is NOT approximately equal to the corresponding resistance in the chart on Pages 24 and 25, replace the probe.
	D. Broken/loose wire between computer and tray heater relay, or failed tray heater relay.	D. Check for 5VDC on terminals 3 & 4 of tray heater relay AND on computer pins 2 & 6. If present on pins 2 & 6, but NOT on terminals 3 & 4, and wiring is intact, replace the tray heater relay.
	E. Failed tray heater.	E. Check for 5VDC on terminals 3 & 4 of main heater relay and for line voltage on terminal 2 of tray heater relay and terminal 4 of latch relay. If expected voltage is present at all three points, replace the tray heater.

## 11.5 PROBE RESISTANCE CHART

<h3 style="text-align: center;">Probe Resistance Chart</h3> <p style="text-align: center;"><i>For use with VT Series toasters manufactured with Minco Thermistor probes only.</i></p>																	
F	OHMS	C	F	OHMS	C	F	OHMS	C	F	OHMS	C	F	OHMS	C	F	OHMS	C
60	1059	16	160	1268	71	260	1473	127	360	1674	182	460	1872	238			
65	1070	18	165	1278	74	265	1483	129	365	1684	185	465	1882	241			
70	1080	21	170	1289	77	270	1493	132	370	1694	188	470	1892	243			
75	1091	24	175	1299	79	275	1503	135	375	1704	191	475	1901	246			
80	1101	27	180	1309	82	280	1514	138	380	1714	193	480	1911	249			
85	1112	29	185	1320	85	285	1524	141	385	1724	196	485	1921	252			
90	1122	32	190	1330	88	290	1534	143	390	1734	199	490	1931	254			
95	1133	35	195	1340	91	295	1544	146	395	1744	202	495	1940	257			
100	1143	38	200	1350	93	300	1554	149	400	1754	204	500	1950	260			
105	1154	41	205	1361	96	305	1564	152	405	1764	207	505	1960	263			
110	1164	43	210	1371	99	310	1574	154	410	1774	210	510	1969	266			
115	1174	46	215	1381	102	315	1584	157	415	1783	213	515	1979	268			
120	1185	49	220	1391	104	320	1594	160	420	1793	216	520	1989	271			
125	1195	52	225	1402	107	325	1604	163	425	1803	218	525	1998	274			
130	1204	54	230	1412	110	330	1614	166	430	1813	221	530	2008	277			
135	1216	57	235	1422	113	335	1624	168	435	1823	224	535	2018	279			
140	1226	60	240	1432	116	340	1634	171	440	1833	227	540	2029	282			
145	1237	63	245	1442	118	345	1644	174	445	1843	229	545	2039	286			
150	1247	66	250	1453	121	350	1654	177	450	1852	232	550	2049	288			
155	1258	68	255	1463	124	355	1664	179	455	1862	235						

# 11.6 WIRING DIAGRAMS

**NOTE:** These diagrams depict wiring as of the date of manual publication. They may not reflect design changes made to the equipment after publication. Always refer to the wiring diagram affixed to the unit when actually troubleshooting or servicing this equipment.

## NON-CE TOASTERS

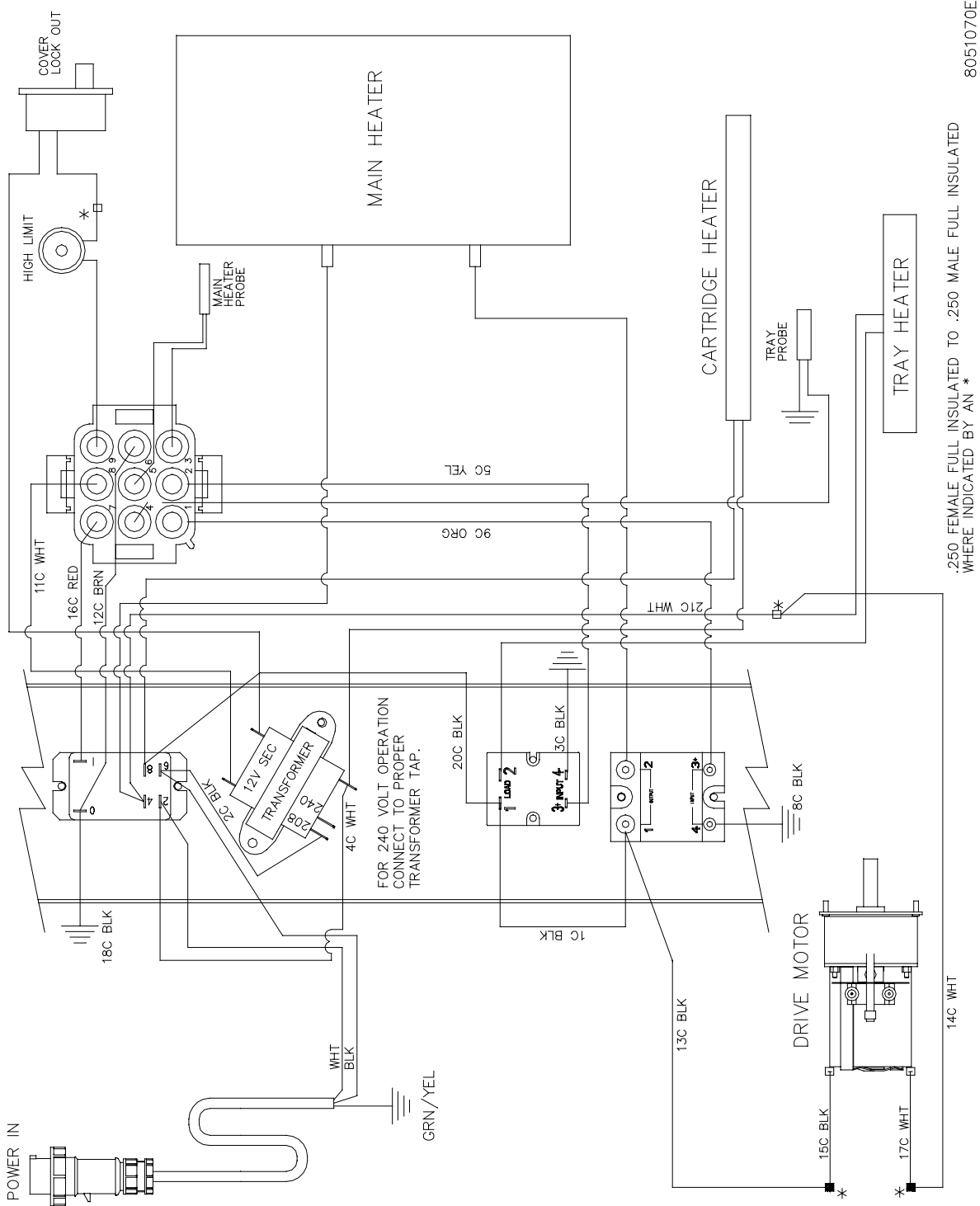

8051070E

# CE AND AUSTRALIAN TOASTERS

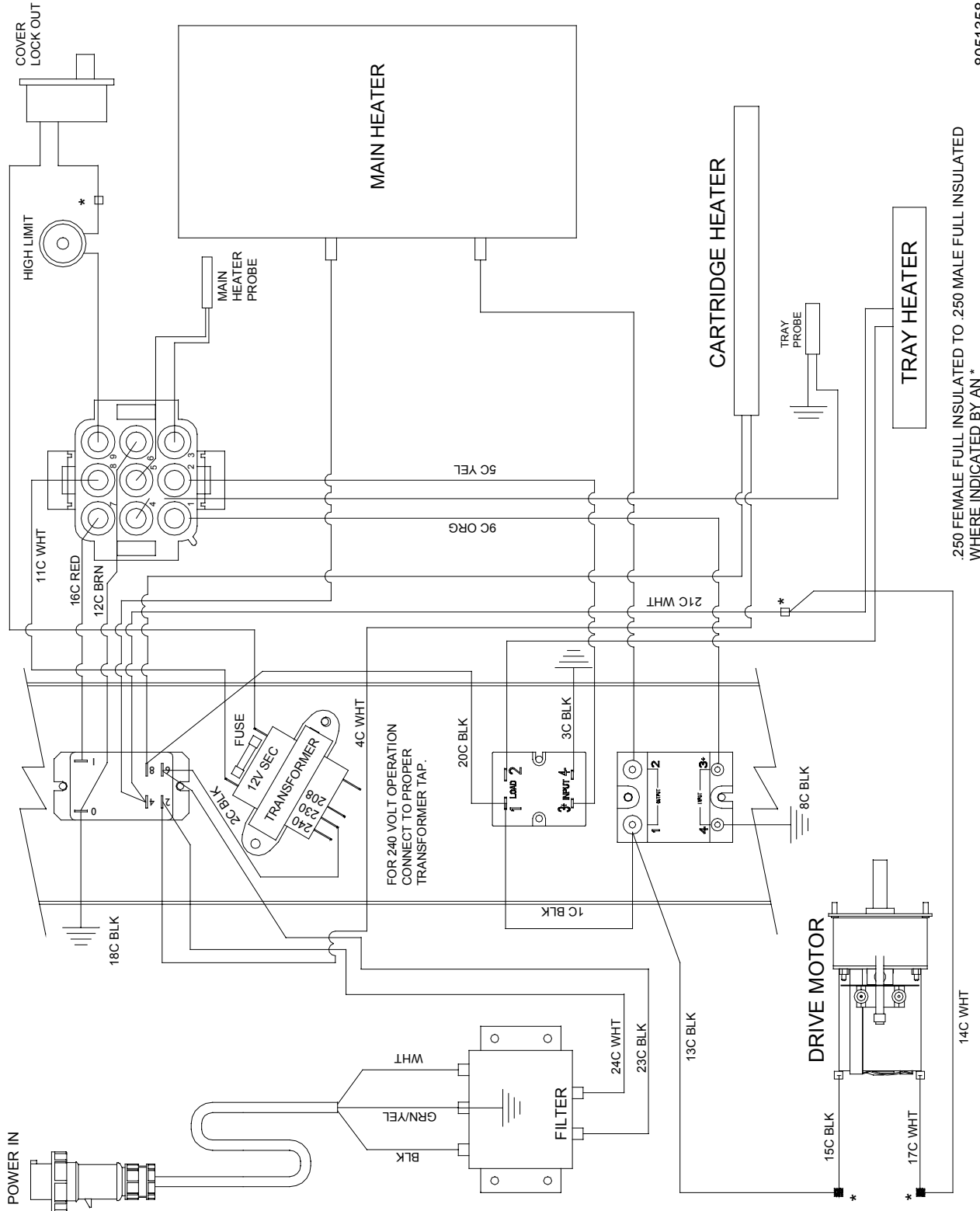

8051358A

# 11.7 SCHEMATIC

