



YFPRE SERIES ELECTRIC FRYERS

Service & Parts Manual



Frymaster, a member of the Commercial Food Equipment Service Association, recommends using CFESA Certified Technicians.

24-Hour Service Hotline 1-800-551-8633

www.frymaster.com

E-mail: service@frymaster.com

MAR 2013



8 1 9 6 4 2 8

NOTICE

IF, DURING THE WARRANTY PERIOD, THE CUSTOMER USES A PART FOR THIS MANITOWOC EQUIPMENT OTHER THAN AN UNMODIFIED NEW OR RECYCLED PART PURCHASED DIRECTLY FROM FRYMASTER DEAN, OR ANY OF ITS AUTHORIZED SERVICE CENTERS, AND/OR THE PART BEING USED IS MODIFIED FROM ITS ORIGINAL CONFIGURATION, THIS WARRANTY WILL BE VOID. FURTHER, FRYMASTER DEAN AND ITS AFFILIATES WILL NOT BE LIABLE FOR ANY CLAIMS, DAMAGES OR EXPENSES INCURRED BY THE CUSTOMER WHICH ARISE DIRECTLY OR INDIRECTLY, IN WHOLE OR IN PART, DUE TO THE INSTALLATION OF ANY MODIFIED PART AND/OR PART RECEIVED FROM AN UNAUTHORIZED SERVICE CENTER.

⚠ DANGER

Copper wire suitable for at least 167°F (75°C) must be used for power connections.

⚠ DANGER

The electrical power supply for this appliance must be the same as indicated on the rating and serial number plate located on the inside of the fryer door.

⚠ DANGER

This appliance must be connected to the voltage and phase as specified on the rating and serial number plate located on the inside of the fryer door.

⚠ DANGER

All wiring connections for this appliance must be made in accordance with the wiring diagrams furnished with the equipment. Wiring diagrams are located on the inside of the fryer door.

⚠ DANGER

Do not store or use gasoline or other flammable vapors and liquids in the vicinity of this or any other appliance.

⚠ WARNING

Do not attach accessories to this fryer unless fryer is secured from tipping. Personal injury may result.

⚠ WARNING

Frymaster fryers equipped with legs are for permanent installations. Fryers fitted with legs must be lifted during movement to avoid damage and possible bodily injury. For a moveable or portable installation, Frymaster optional equipment casters must be used. Questions? Call 1-800-551-8633 or email at service@frymaster.com.

⚠ WARNING

Do not use water jets to clean this equipment.

⚠ WARNING

This equipment is intended for indoor use only. Do not install or operate this equipment in outdoor areas.

⚠ DANGER

Adequate means must be provided to limit the movement of this appliance without depending on or transmitting stress to the electrical conduit. A restraint kit is provided with the fryer. If the restraint kit is missing contact your local Factory Authorized Servicer (FAS) for part number 826-0900.

⚠ DANGER

Prior to movement, testing, maintenance and any repair on your Frymaster fryer, disconnect all electrical power from the fryer.

YFPRE SERIES ELECTRIC FRYERS

TABLE OF CONTENTS

CAUTIONARY STATEMENTS.....	i
----------------------------	---

CHAPTER 1: Service Procedures

1.1	General	1-1
1.2	Replacing a Controller.....	1-1
1.3	Replacing Component Box Components	1-1
1.4	Replacing a High-Limit Thermostat.....	1-2
1.5	Replacing a Temperature Probe	1-3
1.6	Replacing a Heating Element	1-5
1.7	Replacing Contactor Box Components	1-6
1.8	Replacing a Frypot	1-7
1.9	Built-In Filtration System Service Procedures	1-9
1.9.1	Filtration System Problem Resolution	1-9
1.9.2	Replacing the Filter Motor, Filter Pump and Related Components	1-10
1.9.3	Replacing the Filter Transformer or Filter Relay	1-12
1.10	Interface Board Diagnostic Chart.....	1-13
1.11	Probe Resistance Chart.....	1-14
1.12	Wiring Diagrams	1-15
1.12.1	Standard Wiring YFPRE	1-15
1.12.2	Tilt Switch Wiring.....	1-16
1.12.3	Terminal Block Wiring	1-16
1.12.4	Contactor Box - 3 Phase/Delta Configuration.....	1-17
1.12.5	Contactor Box - Single Phase Configuration	1-18

CHAPTER 2: Parts List

2.1	Accessories	2-1
2.2	Cabinetry	2-2
2.3	Drain Valve	2-4
2.4	Electronics and Electrical Components.....	2-5
2.4.1	Element Assembly and Hardware	2-5
2.4.2	Tilt Switch Assembly	2-6
2.4.3	Controllers	2-7
2.4.4	Contactor Boxes	2-8
2.4.5	Component Boxes	2-9
2.5	Wiring	2-10
2.5.1	Contactor Box Wiring Assembly, 12-Pin (Control).....	2-10
2.5.2	Contactor Box Wiring Assembly, MDI, 6-Pin (Left Element)	2-10
2.5.3	Contactor Box Wiring Assembly, MDI, 9-Pin (Right Element).....	2-10
2.5.4	Component Box to Filter Pump Harness.....	2-11
2.5.5	Main Wiring Harnesses	2-11
2.5.6	Component Box and Filter Pump.....	2-11
2.6	Filtration System Components	2-12
2.7	Frypots and Associated Components	2-14
2.8	Wiring and Pin Connectors	2-14
2.9	Fasteners	2-15

YFPRE SERIES ELECTRIC FRYERS

CHAPTER 1: SERVICE PROCEDURES

1.1 General

Before performing any maintenance on your Frymaster fryer, disconnect the fryer from the electrical power supply.

When electrical wires are disconnected, it is recommended that they be marked to facilitate re-assembly.

1.2 Replacing a Controller

1. Disconnect the fryer from the electrical power supply.
2. The controller bezel is held in place by tabs at the top and bottom. Slide the metal bezel up to disengage the lower tabs. Then slide the bezel down to disengage the upper tabs.
3. Remove the two screws from the upper corners of the control panel. The control panel is hinged at the bottom and swings open from the top.
4. Unplug the wiring harness from the connector on the back of the controller and disconnect the grounding wire from terminal adjacent to the connector. Remove the control panel assembly by lifting it from the hinged slots in the control panel frame.



5. Remove the controller from the control panel assembly and install the replacement controller. Reinstall the control panel assembly by reversing Steps 1 and 2.

1.3 Replacing Component Box Components

1. Disconnect the fryer from the electrical power supply.

2. The controller bezel is held in place by tabs at the top and bottom. Slide the metal bezel up to disengage the lower tabs. Then slide the bezel down to disengage the upper tabs.
3. Remove the two screws from the upper corners of the control panel and allow the control panel to swing down.
4. Unplug the wiring harness from the 15-pin connector on the interface board and disconnect the grounding wire from terminal adjacent to the 15-pin connector on the back of the controller. Remove the control panel assembly by lifting it from the hinge slots in the control panel frame.
5. Disconnect the wiring from the component to be replaced, being sure to make a note of where each wire was connected.
6. Dismount the component to be replaced and install the new component, being sure that any required spacers, insulation, washers, etc. are in place.

NOTE: If more room to work is required, the control panel frame assembly may be removed by removing the hex head screws that secure it to the fryer cabinet (see illustration below). *Removing the component box itself from the fryer is not recommended due to the difficulty involved in disconnecting and reconnecting the oil-return valve rods, which pass through openings in the component box.*

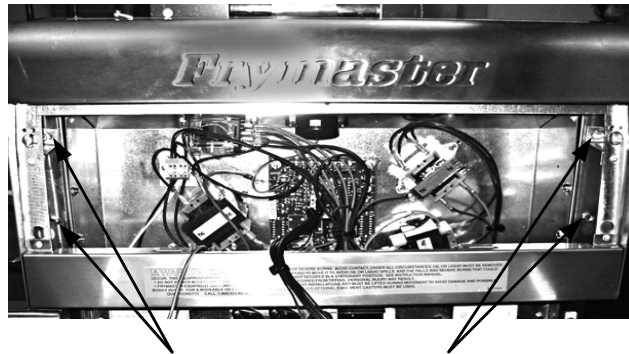

Removing the Control Panel Frame and Top Cap Assembly

7. Reconnect the wiring disconnected in Step 3, referring to your notes and the wiring diagrams on the fryer door to ensure that the connections are properly made. Also, verify that no other wiring was disconnected accidentally during the replacement process.
8. Reverse Steps 1 through 4 to complete the replacement and return the fryer to service.

1.4 Replacing a High-Limit Thermostat

1. Remove the filter pan and lid from the unit. Drain the frypot into a Shortening Disposal Unit (SDU) or other appropriate metal container.

⚠ DANGER

DO NOT drain more than one full frypot or two split frypots into the SDU at one time.

2. Disconnect the fryer from the electrical power supply and reposition it to gain access to the rear of the fryer.
3. Remove the four screws from both the left and right sides of the lower back panel.
4. Locate the high-limit that is being replaced and follow the two-black wires to the 12-pin connector C-6. Note where the leads are connected prior to removing them from the connector. Unplug the 12-pin connector C-6 and using a pin-pusher push the pins of the high-limit out of the connector.
5. Using a wrench, carefully unscrew the high-limit thermostat to be replaced.
6. Apply Loctite™ PST 567 or equivalent sealant to the threads of the replacement and screw it securely into the frypot.
7. Insert the leads into the 12-pin connector C-6 (see illustration below). For full-vat units, the leads go into positions 1 and 2 of the connector and polarity does not matter.

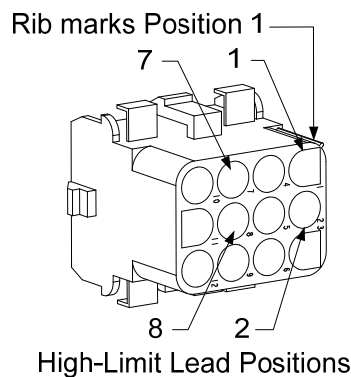

8. Reconnect the 12-pin connecting plug C-6. Use wire ties to secure any loose wires.
9. Reinstall the back panels reposition the fryer under the exhaust hood, and reconnect it to the electrical power supply to return the fryer to service.

1.5 Replacing a Temperature Probe

1. Remove the filter pan and lid from the unit. Drain the frypot into a Shortening Disposal Unit (SDU) or other appropriate metal container.

⚠ DANGER

DO NOT drain more than one full frypot or two split frypots into the SDU at one time.

2. Disconnect the fryer from the electrical power supply and reposition it to gain access to the rear of the fryer.
3. Remove the four screws from both sides of the lower back panel. Then remove the two screws on both the left and right sides of the back of the tilt housing. Lift the tilt housing straight up to remove from the fryer.

4. Locate the red and white wires of the temperature probe to be replaced. Note where the leads are connected prior to removing them from the connector. Unplug the 12-pin connector C-6 and using a pin-pusher push the pins of the temperature probe out of the connector.
5. Raise the element and remove the securing probe bracket and metal tie wraps that secure the probe to the element (see illustration below).

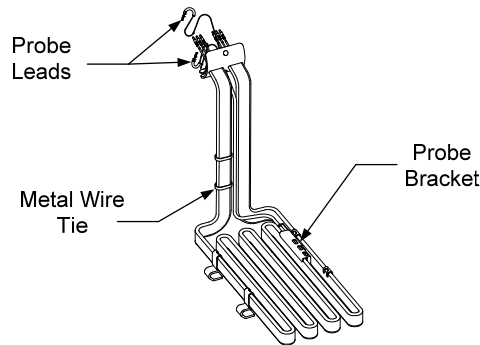

6. Gently pull on the temperature probe and grommet, pulling the wires up the rear of the fryer and through the element tube assembly.
7. Insert the replacement temperature probe (wires first) into the tube assembly ensuring that the grommet is in place. Secure the probe to the elements using the bracket which was removed in Step 5 and the metal tie wraps which were included in the replacement kit.
8. Route the probe wires out of the tube assembly following the element wires down the back of the fryer through the Heyco bushings to the 12-pin connector C-6. Secure the wires to the sheathing with wire ties.
9. Insert the temperature probe leads into the 12-pin connector C-6 (see illustration below). For full-vat units, the red lead goes into position 3 and the white lead into position 4 of the connector.

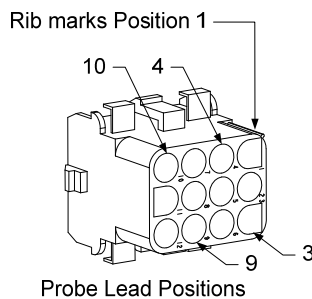

10. Secure any loose wires with wire ties making sure that the lead wires will not interfere with the movement of the springs. Rotate the elements up and down making sure that movement is not restricted and that the wires are not pinched.
11. Reinstall the tilt housing and back panels, reposition the fryer under the exhaust hood, and reconnect it to the electrical power supply to return the fryer to service.

1.6 Replacing a Heating Element

1. Perform Steps 1-3 of section 1.5, *Replacing a Temperature Probe*.
2. On full-vat fryers where the temperature probe is attached to the element being replaced, disconnect the wire harness containing the probe wiring. Using a pin pusher, disconnect the probe wires from the 12-pin connector C-6.
3. In the rear of the fryer directly behind the frypot, disconnect the 6-pin connector for the left element (as viewed from the front of the fryer) or the 9-pin connector for the right element. Press in on the tabs on each side of the connector while pulling outward on the free end to extend the connector and release the element leads (see photo below). Pull the leads out of the connector and out of the wire sleeving.

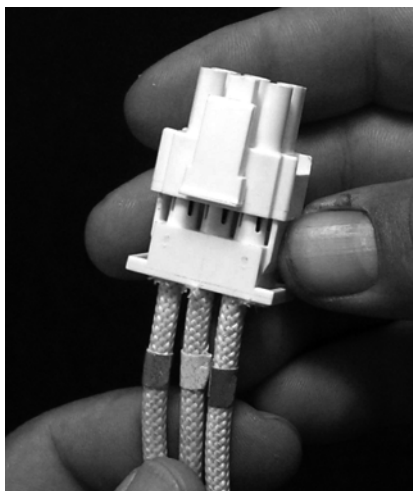

4. Raise the element to the full up position and support the elements.
5. Remove the hex head screws and nuts that secure the element to the tube assembly and pull the element out of the frypot. **NOTE:** Full-vat elements consist of two dual-vat elements clamped together. For full-vat units, remove the element clamps before removing the nuts and screws that secure the element to the tube assembly.
6. If applicable, recover the probe bracket and probe from the element being replaced and install them on the replacement element. Install the replacement element in the frypot, securing it with the nuts and screws removed in Step 5 to the tube assembly. Ensure the gasket is between the tube and element assembly.
7. Route the element leads through the element tube assembly and into the wire sleeving to prevent chafing. Ensure that the wire sleeving is routed back through the Heyco bushing keeping it clear from the lift springs. Also, ensure that the wire sleeving extends into the tube assembly to prevent the edge of the tube assembly from chafing the wires. Press the pins into the connector in accordance with the diagram below, and then close the connector to lock the leads in place. **NOTE:** It is critical that the wires be routed through the sleeving to prevent chafing.

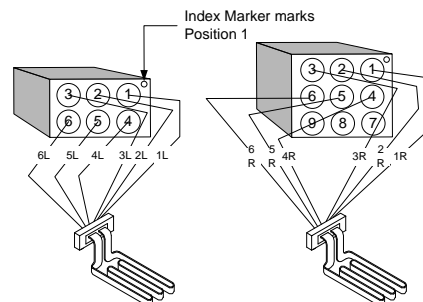

8. Reconnect the element connector ensuring that the latches lock.
9. Insert the temperature probe leads into the 12-pin wiring harness connector C-6 (see illustration below). For full-vat, the red lead goes into position 3 and the white into position 4.

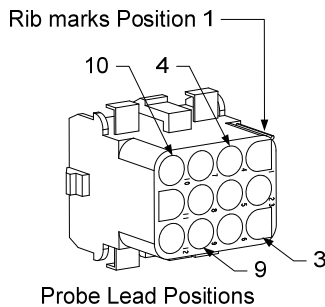

10. Reconnect the 12-pin connector C-6 of the wiring harness disconnected in Step 2.
11. Lower the element down onto the basket rack.
12. Reinstall the tilt housing and back panels, reposition the fryer under the exhaust hood, and reconnect it to the electrical power supply.

1.7 Replacing Contactor Box Components

1. Remove the filter pan and lid from the unit.
2. Disconnect the fryer from the electrical power supply.
3. Remove lower back of fryer.
4. Remove the two screws in the element wire bracket (white arrow) and the six screws on the contactor box (black arrows). Remove the back of the contactor box, leaving the lid and box in place.

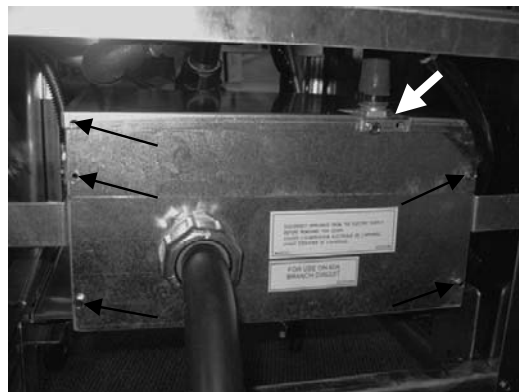

Remove the two screws in the element bracket (white arrow) and six screws on the contactor box (black arrows) before attempting to remove the box.

5. Unplug the elements wires (white wires with plugs) inside component box.
6. Remove the lid.
7. Remove the screw (white arrows below) from each of the tabs on either side of the contactor box.



Remove the screws (white arrows) from the tabs on either side of the contactor box.

8. Unplug the 12-pin control cord inside the box.
9. Carefully lower the contactor box out of the fryer cabinet. Ensure no wires are pulled or damaged in the process.
10. The contactors and relays are held on by threaded pin studs so that only removal of the nut is required to replace the component.
11. To reinstall the contactor box, reverse Steps 1-7 to return the fryer to operation.

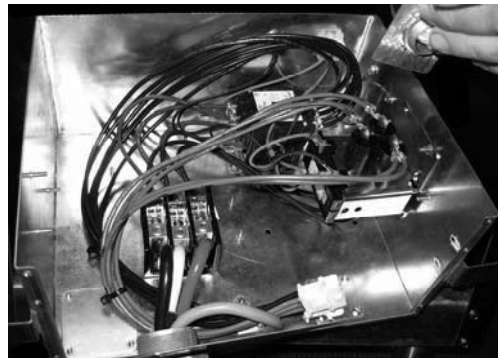

Contactor box components.

1.8 Replacing a Frypot

1. Drain the frypot into a Shortening Disposal Unit (SDU) or other appropriate metal container. Remove the filter pan and lid from the unit.

⚠ DANGER
DO NOT drain more than one full frypot or two split frypots into the SDU at one time.

2. Disconnect the fryer from the electrical power supply and reposition it to gain access to both the front and rear.
3. Slide the metal bezel up to release the bottom tabs, then slide the bezel down to disengage the upper tabs.
4. Remove the two screws from the upper corners of the control panel and allow it to swing down (see illustration and photo on page 1-1).
5. Unplug the wiring harnesses and ground wire from the back of the controller. Remove the controller by lifting it from the hinge slots in the control panel frame.
6. Remove the tilt housing and back panels from the fryer. The tilt housing must be removed first in order to remove the upper back panel.
7. To remove the tilt housing, remove the hex head screws from the rear edge of the housing. The housing can be lifted straight up and off the fryer.
8. Remove the control panel by removing the screw in the center and the nuts on both sides.
9. Loosen the component box by removing the screws that secure them in the cabinet.
10. Dismount the top cap by removing the nuts at each end that secure it to the cabinetry.
11. Remove the hex head screw that secures the front of the frypot to the cabinet cross brace.
12. Remove the piece of drain tubing attached to the drain valve.
13. Remove the cover from the drain safety switch and disconnect the switch wiring at the switch.
14. At the rear of the fryer, unplug the 12-pin connector C-6 and, using a pin pusher, disconnect the high-limit thermostat leads.
15. Disconnect the oil return flexline(s) at the frypot end.
16. Raise the elements to the “up” position and disconnect the element springs.
17. Remove the machine screws and nuts that secure the element tube assembly to the frypot. Carefully lift the element assembly from the frypot and secure it to the cross brace on the rear of the fryer with wire ties or tape.
18. Carefully lift the frypot from the fryer and place it upside down on a stable work surface.
19. Recover the drain valve, oil return flexline connection fitting, and high-limit thermostat from the frypot. Clean threads and apply Loctite™ PST 567 or equivalent sealant to the threads of the recovered parts and install them in the replacement frypot.
20. Carefully lower the replacement frypot into the fryer. Reinstall the hex head screw removed in Step 7 to attach the frypot to the fryer.

21. Position the element tube assembly in the frypot and reinstall the machine screws and nuts removed in Step 14.
22. Reconnect the oil return flexline(s) to the frypot, and replace aluminum tape, if necessary, to secure heater strips to the flexline(s).
23. Insert the high-limit thermostat leads disconnected in Step 13 (see illustration on page 1-3 for pin positions).
24. Reconnect the drain safety switch wiring to the switch in accordance with the diagram below then reinstall the switch cover.

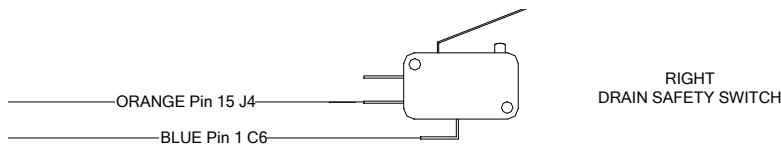

25. Reinstall the drain tube assembly.
26. Reinstall the top cap, control panel, component box, tilt housing and back panels.
27. Reinstall the controller in the control panel frame and reconnect the wiring harnesses and ground wire.
28. Reposition the fryer under the exhaust hood and reconnect it to the electrical power supply.

1.9 Built-in Filtration System Service Procedures

1.9.1 Filtration System Problem Resolution

One of the most common causes of filtration problems is placing the filter paper on the bottom of the filter pan rather than over the filter screen.

⚠ CAUTION
Ensure that filter screen is in place prior to filter paper placement and filter pump operation. Improper screen placement is the primary cause of filtration system malfunction.

Whenever the complaint is “the pump is running, but no oil is being filtered,” check the installation of the filter paper, and ensure that the correct size is being used. While you are checking the filter paper, verify that the O-rings on the pick-up tube of the filter pan are in good condition. Missing or worn O-rings allow the pump to take in air and decrease its efficiency.

If the pump motor overheats, the thermal overload will trip and the motor will not start until it is reset. If the pump motor does not start, press the red reset switch (button) located on the rear of the motor at the front of the fryer.

If the pump starts after resetting the thermal overload switch, then something is causing the motor to overheat. A major cause of overheating is when several frypots are filtered sequentially, overheating the pump and motor. Allow the pump motor to cool at least 30 minutes before resuming operation. Pump overheating can be caused by:

- Solidified shortening in the pan or filter lines, or
- Attempting to filter unheated oil (cold oil is more viscous, overloading the pump motor and causing it to overheat).

If the motor runs but the pump does not return oil, there is a blockage in the pump. Incorrectly sized or installed paper/pads will allow food particles and sediment to pass through the filter pan and into the pump. When sediment enters the pump, the gears bind, causing the motor to overload, again tripping the thermal overload. Shortening that has solidified in the pump will also cause it to seize, with the same result.

A pump seized by debris or hard shortening can usually be freed by manually moving the gears with a screwdriver or other instrument.

Disconnect power to the filter system, remove the input plumbing from the pump, and use a screwdriver to manually turn the gears.

- Turning the pump gears in reverse will release a hard particle.
- Turning the pump gears forward will push softer objects and solid shortening through the pump and allow free movement of the gears.

Incorrectly sized or installed paper/pads will also allow food particles and sediment to pass through and clog the suction tube on the bottom of the filter pan. Particles large enough to block the suction tube may indicate that the crumb tray is not being used. Pan blockage can also occur if shortening is left in the pan and allowed to solidify. Blockage removal can be accomplished by forcing the item out with an auger or drain snake. Compressed air or other pressurized gases should not be used to force out the blockage.

1.9.2 Replacing the Filter Motor, Filter Pump, and Related Components

1. Remove the filter pan and lid from the unit. Drain the frypot into a Shortening Disposal Unit (SDU) or other appropriate metal container.

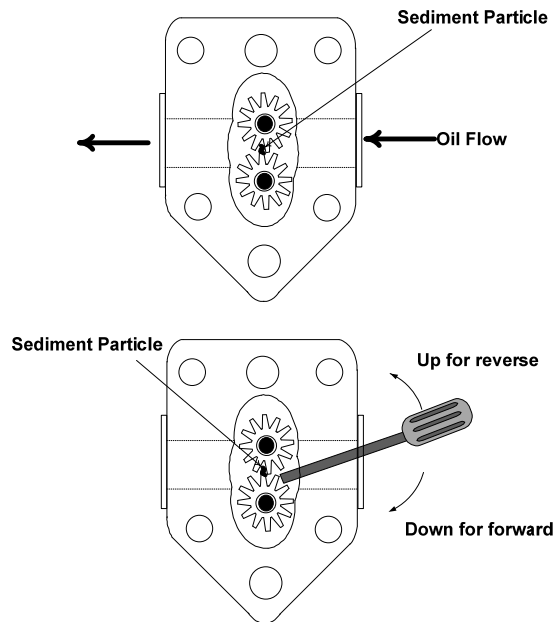

⚠ DANGER
DO NOT drain more than one full frypot or two split frypots into the SDU at one time.

2. Disconnect the fryer from the electrical power supply and reposition it to gain access to both the front and rear.
3. Disconnect the flexlines running to the oil-return manifold at the rear of the fryer as well as the pump suction flexlines at the end of the filter pan connection (see photos below).



Disconnect flexlines indicated by the arrows.

4. Loosen the nut and bolt that secures the bridge to the oil-return manifold.
5. Remove the cover plate from the front of the motor and disconnect the motor wires.
6. Unplug the pump motor assembly 6-pin connector C-2 and, using a pin pusher, disconnect the vent vacuum-breaker solenoid (pins 2 and 5) that is attached to the oil return manifold.
7. Remove the two nuts and bolts that secure the front of the bridge to the cross brace and carefully slide the bridge rearward off the cross brace until its front end can be lowered to the floor. Undo the single nut holding it in place in back. Be careful not to let the rear of the bridge slip off the manifold at this point.
8. Get a good grip on the bridge, carefully pull it forward off the oil-return manifold, and lower the entire assembly to the floor. Once on the floor, pull the assembly out the front of the fryer.
9. When required service has been completed, reverse Steps 6-12 to reinstall the bridge.

NOTE: The black motor wires go on the top terminal, the white on the bottom. The pump solenoid valve wires go in positions 1 and 4 of the 6-pin connector C-2; the vent vacuum-breaker solenoid valve wires go in positions 2 and 5; the red/black heater tape wires go into position 3 and the violet/white wires go into position 6 (see illustration on the following page).

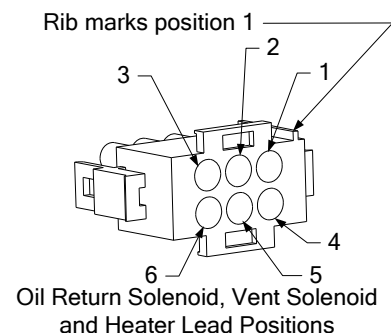

10. Reconnect the unit to the electrical power supply, and verify that the pump is functioning correctly (i.e., when a filter handle is placed in the ON position, the motor should start and there should be strong suction at the intake fitting and outflow at the rear flush port.)
11. When proper operation has been verified, reinstall the back panels and the filter pan and lid.
12. Reposition the fryer under the exhaust hood and reconnect it to the electrical power supply to return the fryer to service.

1.9.3 Replacing the Filter Transformer or Filter Relay

Disconnect the fryer from the electrical power supply. Remove the controller from the fryer to expose the interior of the component box. The filter transformer and relay are located as shown in the illustration on the next page. The components are held on by threaded pin studs so that only removal of the nut is required to replace the component.

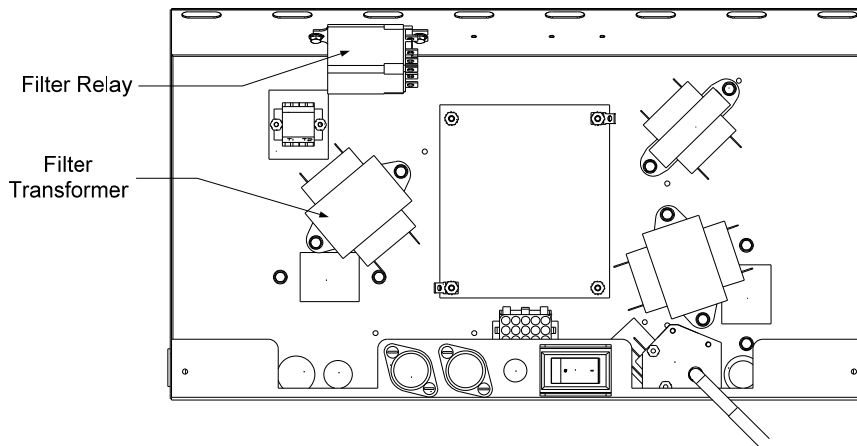

1.10 Interface Board Diagnostic Chart

The following diagram and charts provide ten quick system checks that can be performed using only a multimeter.

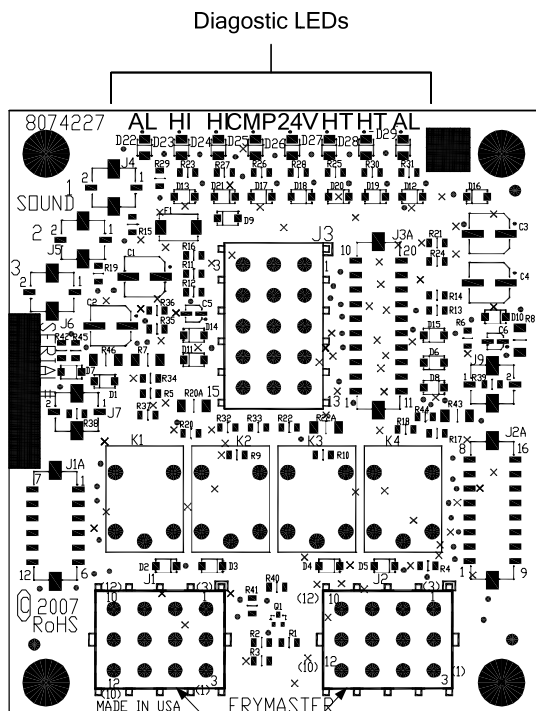

Diagnostic LED Legend

- CMP indicates power from 12V transformer
- 24V indicates power from 24V transformer
- HI (RH) indicates output (closed) from right latch relay
- HI (LH) indicates output (closed) from left latch relay (if present)
- HT (RH) indicates output from right heat relay
- HT (LH) indicates output from left heat relay (if present)
- AL (RH) indicates output (open) from right latch relay
- AL (LH) indicates output (open) from left latch relay (if present)

NOTE - When testing on J1 and/or J2, use the illustration above. Pin 1 is located on the bottom right corner of both J1 and J2. **Disregard any silk-screened or painted numbers on the board showing the location of Pin1.**

Meter Setting	Test	Pin	Pin	Results
12 VAC Power	50 VAC Scale	3 of J2	1 of J2	12-16 VAC
24 VAC Power	50 VAC Scale	2 of J2	Chassis	24-30 VAC
*Probe Resistance	R X 1000 OHMS	11 of J2	10 of J2	See Chart
High-Limit Continuity	R X 1 OHMS	9 of J2	6 of J2	0 - OHMS
Latch Contactor Coil	R X 1 OHMS	8 of J2	Chassis	3-10 OHMS
Heat Contactor Coil	R X 1 OHMS	7 of J2	Chassis	11-15 OHMS

* **Disconnect 15-Pin harness from the computer/controller before testing the probe circuit.**

1.11 Probe Resistance Chart

<h3 style="text-align: center;">Probe Resistance Chart</h3> <p style="text-align: center;"><i>For use with fryers manufactured with Minco Thermistor probes only.</i></p>																	
F	OHMS	C	F	OHMS	C	F	OHMS	C	F	OHMS	C	F	OHMS	C			
60	1059	16	130	1204	54	200	1350	93	270	1493	132	340	1634	171			
65	1070	18	135	1216	57	205	1361	96	275	1503	135	345	1644	174			
70	1080	21	140	1226	60	210	1371	99	280	1514	138	350	1654	177			
75	1091	24	145	1237	63	215	1381	102	285	1524	141	355	1664	179			
80	1101	27	150	1247	66	220	1391	104	290	1534	143	360	1674	182			
85	1112	29	155	1258	68	225	1402	107	295	1544	146	365	1684	185			
90	1122	32	160	1268	71	230	1412	110	300	1554	149	370	1694	188			
95	1133	35	165	1278	74	235	1422	113	305	1564	152	375	1704	191			
100	1143	38	170	1289	77	240	1432	116	310	1574	154	380	1714	193			
105	1154	41	175	1299	79	245	1442	118	315	1584	157	385	1724	196			
110	1164	43	180	1309	82	250	1453	121	320	1594	160	390	1734	199			
115	1174	46	185	1320	85	255	1463	124	325	1604	163	395	1744	202			
120	1185	49	190	1330	88	260	1473	127	330	1614	166	400	1754	204			
125	1195	52	195	1340	91	265	1483	129	335	1624	168	405	1764	207			

1.12 Component Wiring

1.12.1 Standard Wiring YFPRE

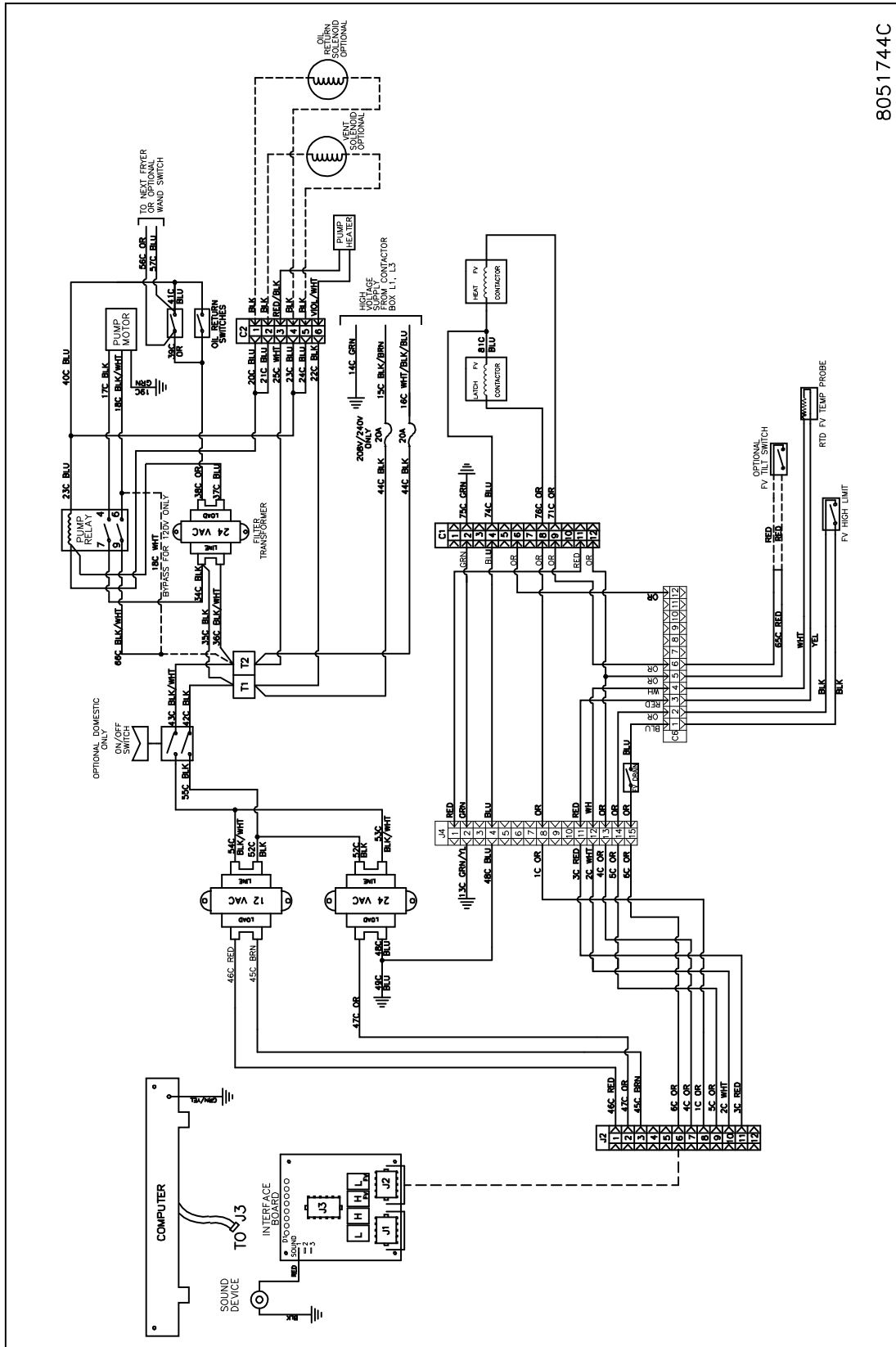

8051744C

1.12.2 Tilt Switch Wiring

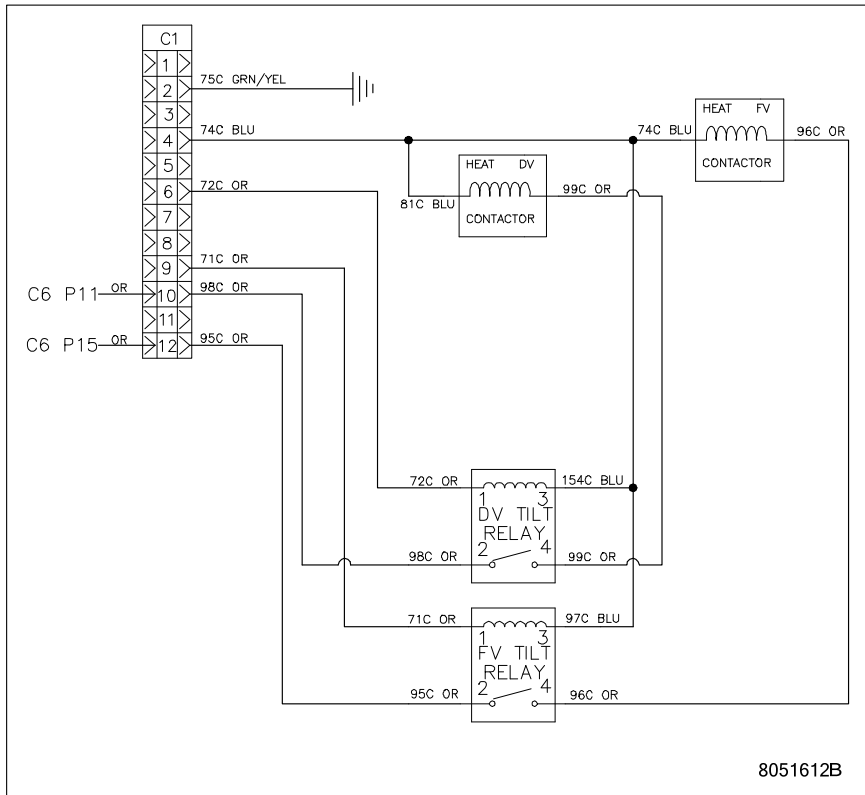

1.12.3 Terminal Block Wiring

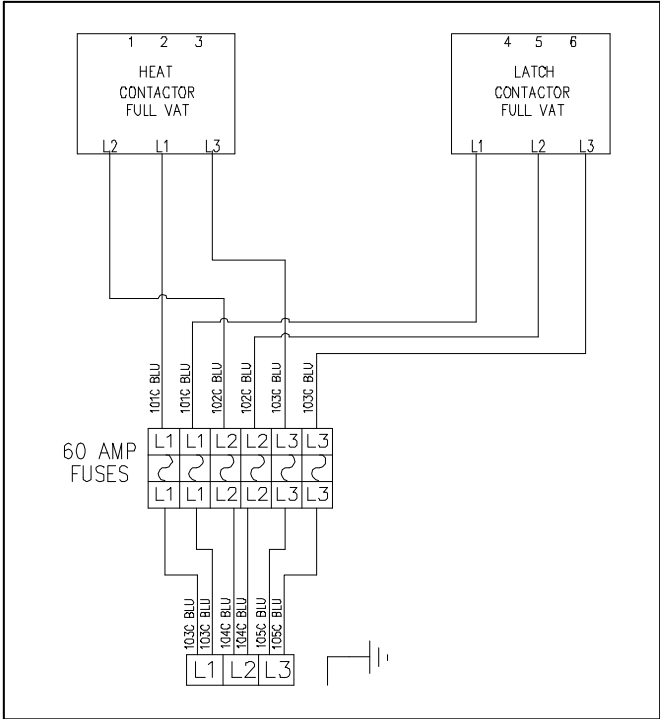

1.12.4 Contactor – DELTA Configuration, 3 Phase

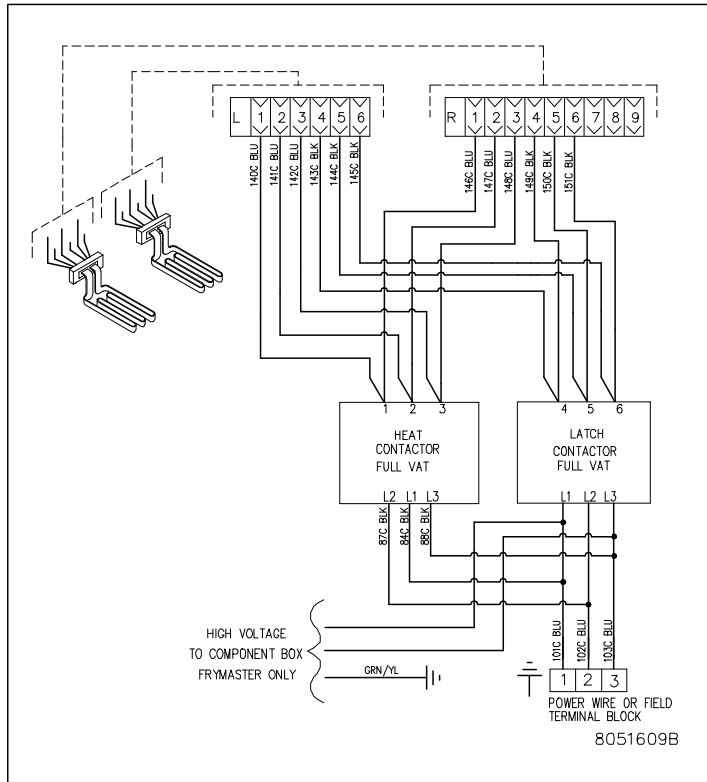

1.12.5 Contactor – WYE Configuration, 3 Phase

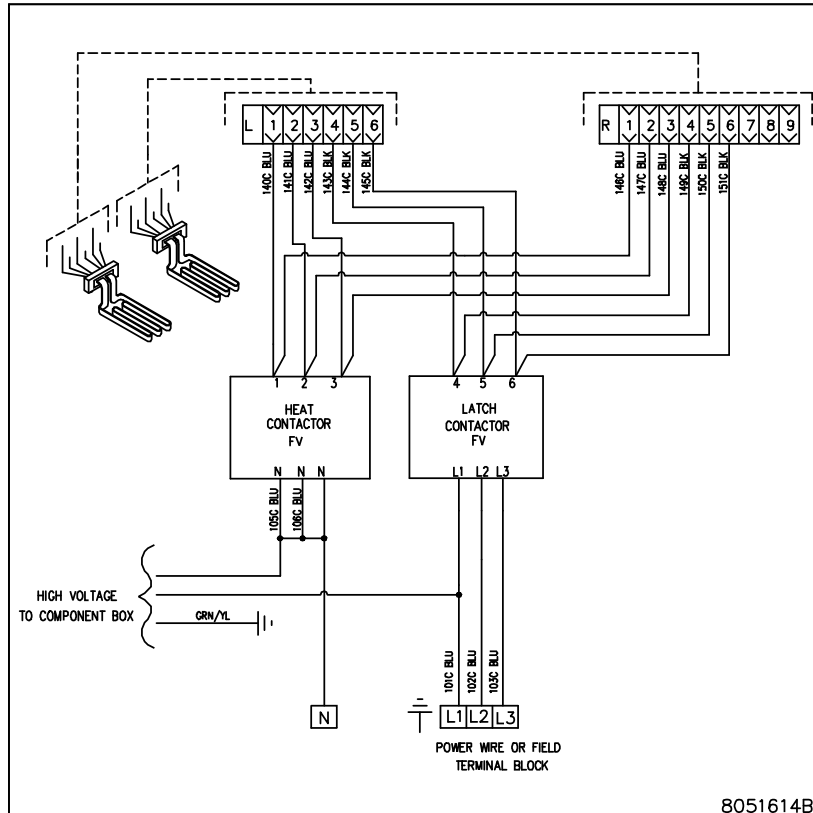

1.12.6 Contactor – Single Phase

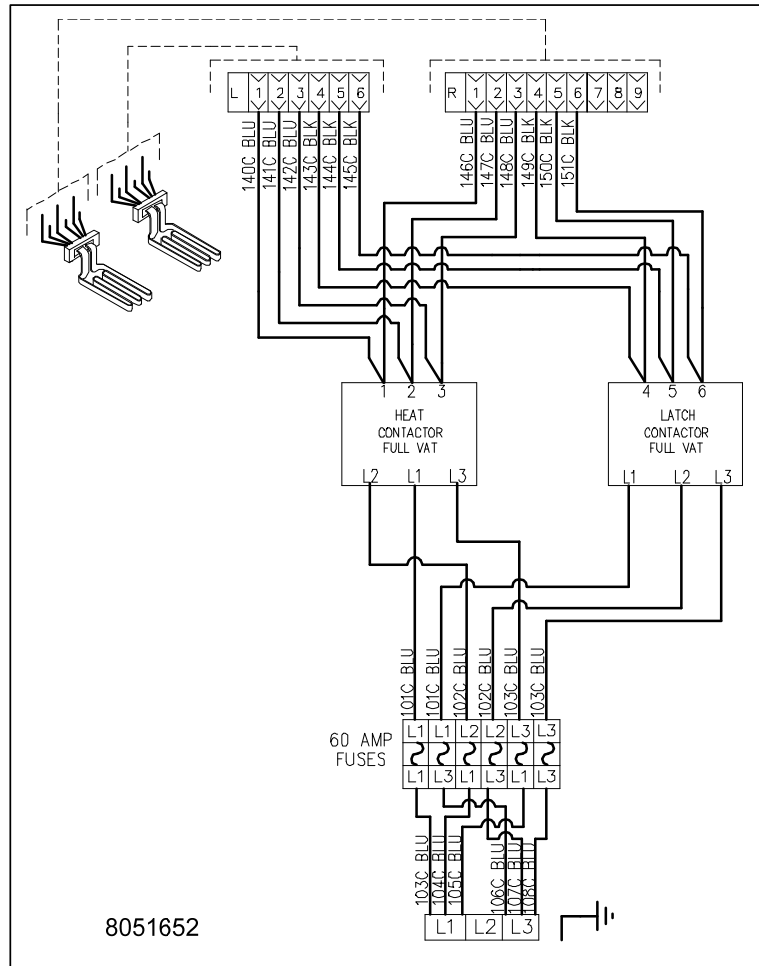

YFPRE SERIES ELECTRIC FRYERS

CHAPTER 2: PARTS LIST

2.1 Accessories

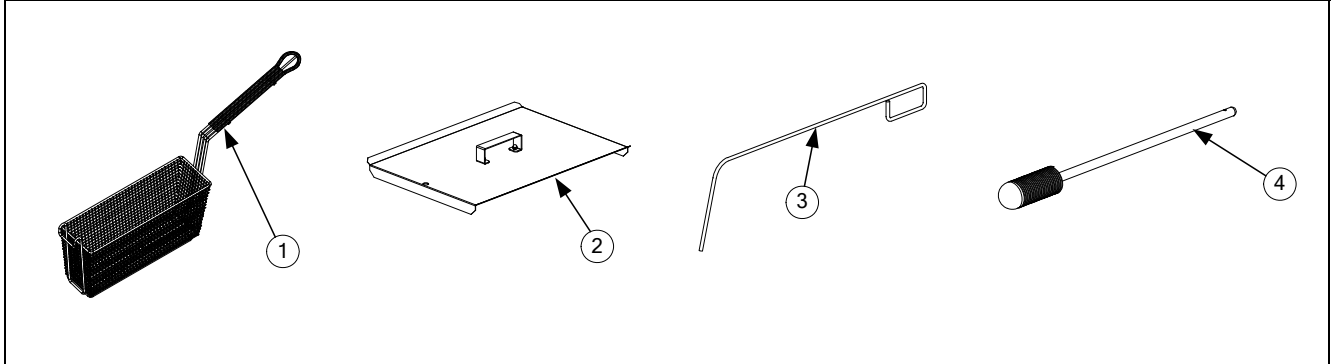

ITEM	PART #	COMPONENT
1	803-0366	Basket, 4-Lane Cooking
2	106-9620	Cover, Full-Vat Frypot
3	803-0278	Brush, Frypot, Teflon
4	803-0197	Cleanout Rod, 27-inch
*	803-0380	Rack, Full-Vat Basket Support
*	803-0002	Powder, Filter (80 1-Cup Applications)
*	803-0170	Pack, 100-Sheet Filter Paper
*	803-0293	Gloves, Hot Oil

* Not illustrated.

2.2 Cabinetry

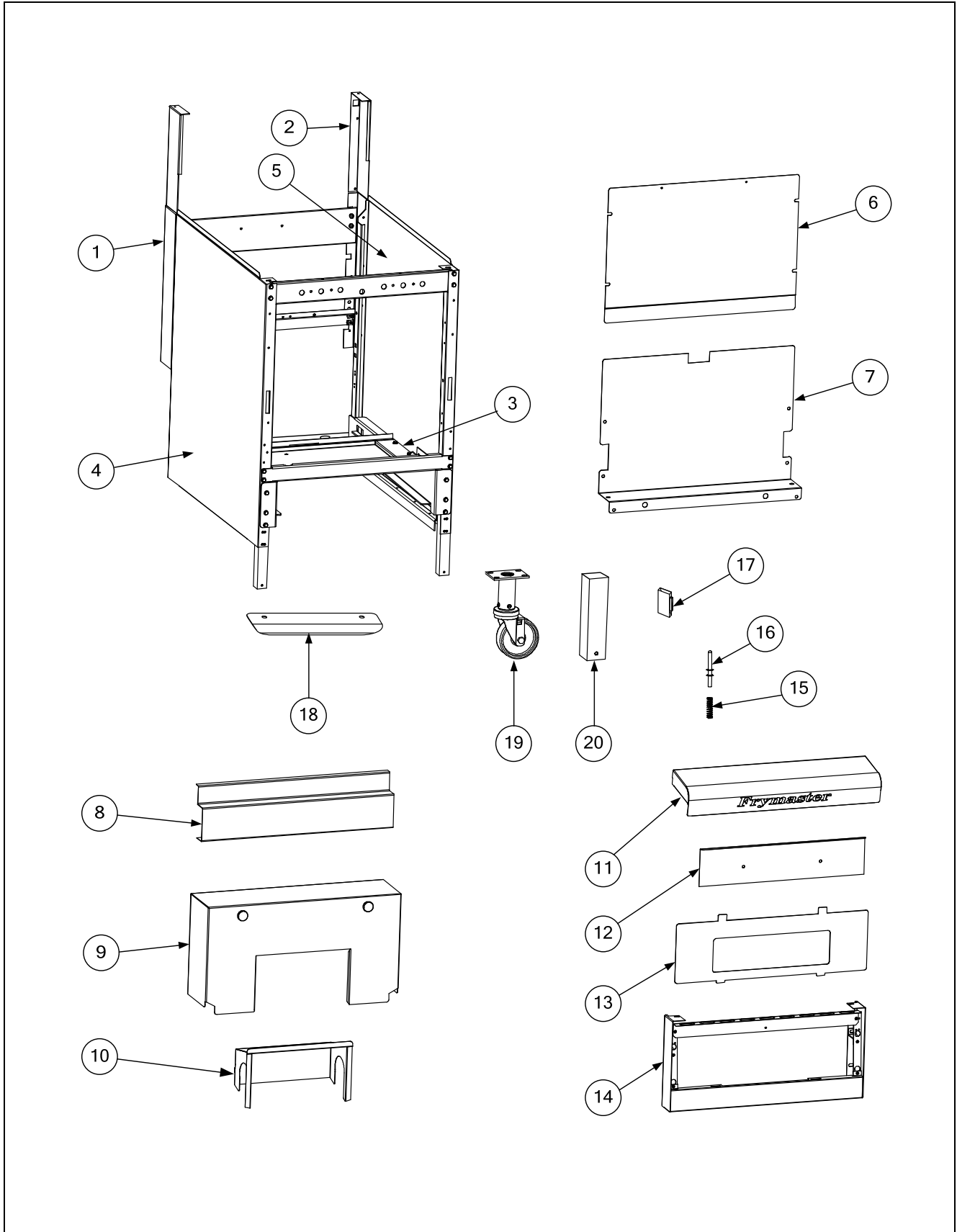

2.2 Cabinetry (cont.)

ITEM	PART #	COMPONENT
	106-9311	Cabinet Assembly
1	106-9431	Upright Assembly, LT Enclosure
2	106-9432	Upright Assembly, RT Enclosure
3	824-1920	Bridge Weldment, Pump/Motor
4	232-4568	Side, RT, Cabinet
5	231-4568	Side, LT, Cabinet
6	220-4316	Back Panel, Upper
7	220-4317	Back Panel, Lower
8	230-4318	Basket Hanger, Wingstreet
9	823-6716	Tilt Housing Single Station
10	823-5440	Cove, Element Tilt Housing
11	108-1722	Top Cap
12	220-4328	Heat Shield, Top Cap
13	230-4332	Bezel, One-Controller
14	106-9346	Frame, Control Panel
	106-7710	Door Assembly
	108-1294	Door Assembly, Heinami
15	810-0275	Spring, Door Pin
16	106-4067	Pin Assembly, Door
17	810-1105	Magnet, Door
18	210-8077	Handle, Eurolook Door
19	812-2227	Rear Caster, without brake
20	810-3010	Leg
*	823-2844	Caster, with brake

2.3 Drain Components

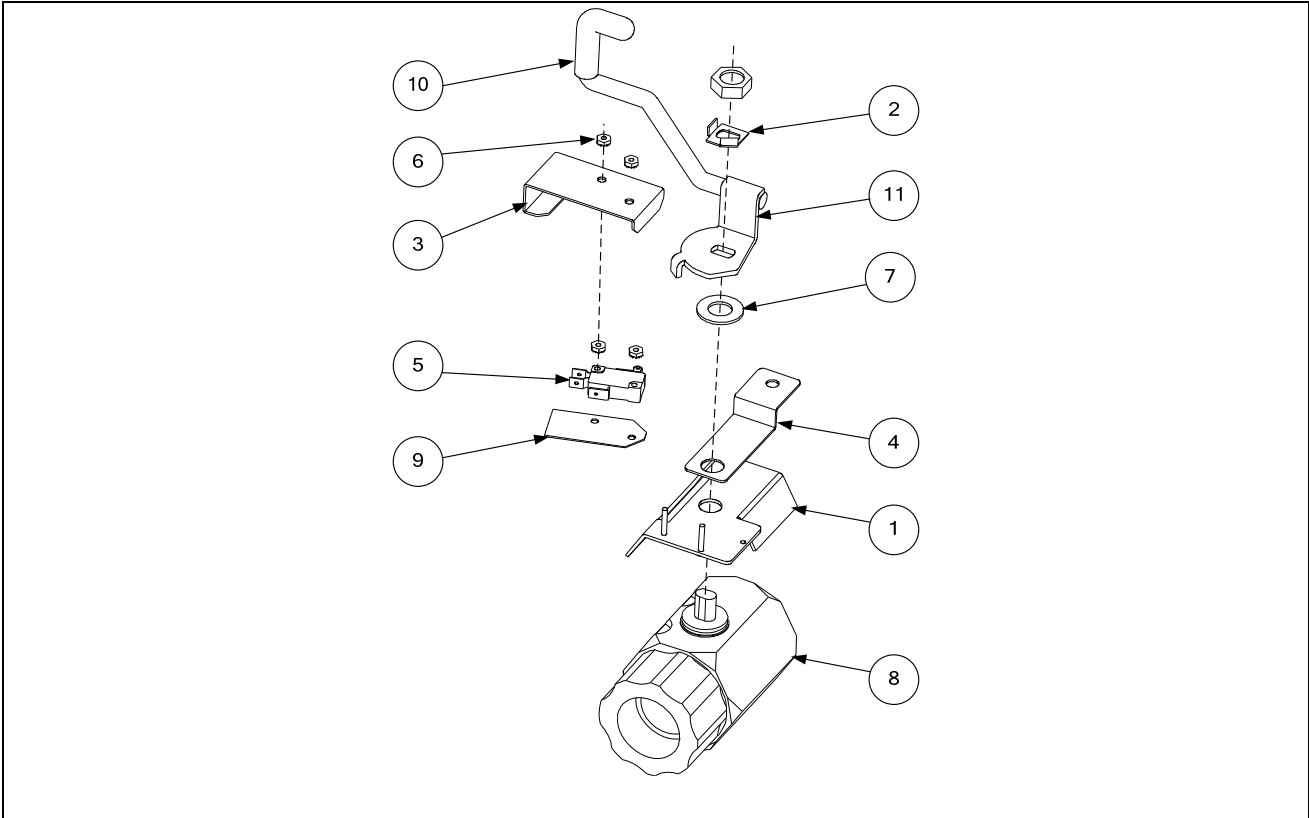

ITEM	PART #	COMPONENT
	106-9351	Drain Valve Assembly
1	106-6020	Bracket, Assembly, 1-1/4" Drain Valve Microswitch
2	200-1257	Retainer, Drain Valve Nut
3	220-0143	Guard, Microswitch Drain
4	220-4497	Strap, 1-1/4" Drain Valve
5	807-2104	Microswitch
6	809-0237	Nut, 4-40 Keps Hex with Extended Tooth
7	809-0988	Washer, 1" OD x .525" ID, Teflon
8	810-2784	Valve, Drain, 1-1/4" Full Port with O-ring
9	816-0220	Insulation, RF Switch
10	816-0549	Cap, Blue Vinyl
11	823-6262	Handle, Drain Valve
*	823-6712	Drain Tube, Downspout

* Not illustrated.

2.4 Electronics and Wiring Components

2.4.1 Heating Elements and Associated Parts

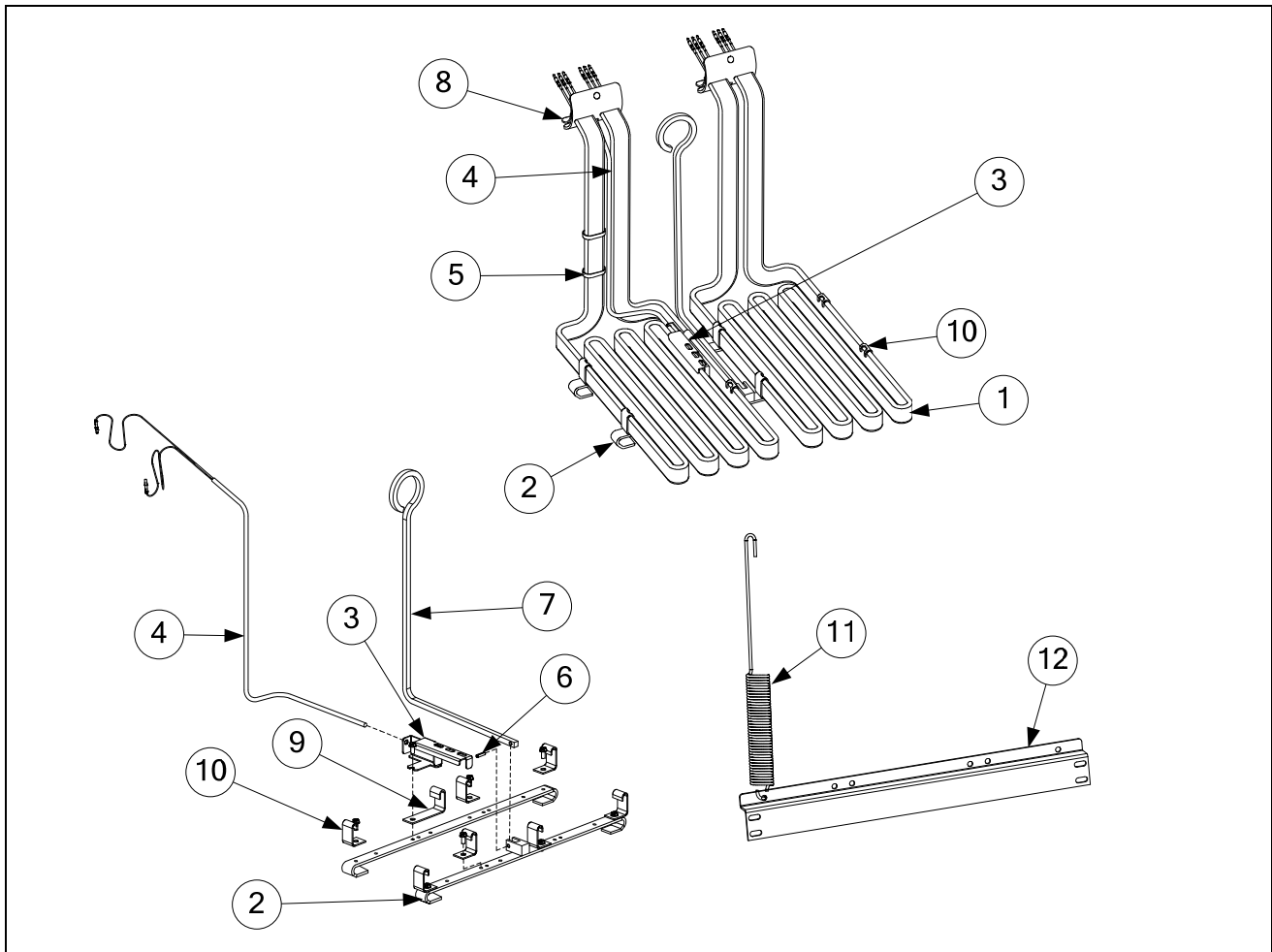

ITEM	PART #	COMPONENT
1	826-2557	Element Kit, 208V (includes items 2-12)
	826-2558	Element Kit, 240V (includes items 2-12)
	826-2707	Element Kit 230V (includes items 2-12)
	807-4653	Element, 208V 8.5 kw (does not include Items 2-12)
	807-4841	Element, 230V 8.5 kw (does not include Items 2-12)
	807-4688	Element, 240V 8.5 kw (does not include Items 2-12)
2	823-6711	Bracket, Element
3	230-0784	Bracket, Temperature Probe
4	826-2652	Probe, Temperature, Wingstreet
5	809-0567	Tie-Wrap, Metal
6	810-1212	Pin, .125 X .5-inch Split
7	810-1233	Handle, Element Lift
8	816-0688	Gasket, Element
9	230-0781	Clamp, Element (Long)
10	910-2042	Clamp, Element (Short)
11	810-3030	Spring, Element Lift, Left
*	810-3031	Spring, Element Lift, Right
12	220-4302	Bracket, Lower Spring
*	816-0681	Grommet, Probe

* Not illustrated.

2.4.2 Tilt Switch Assembly

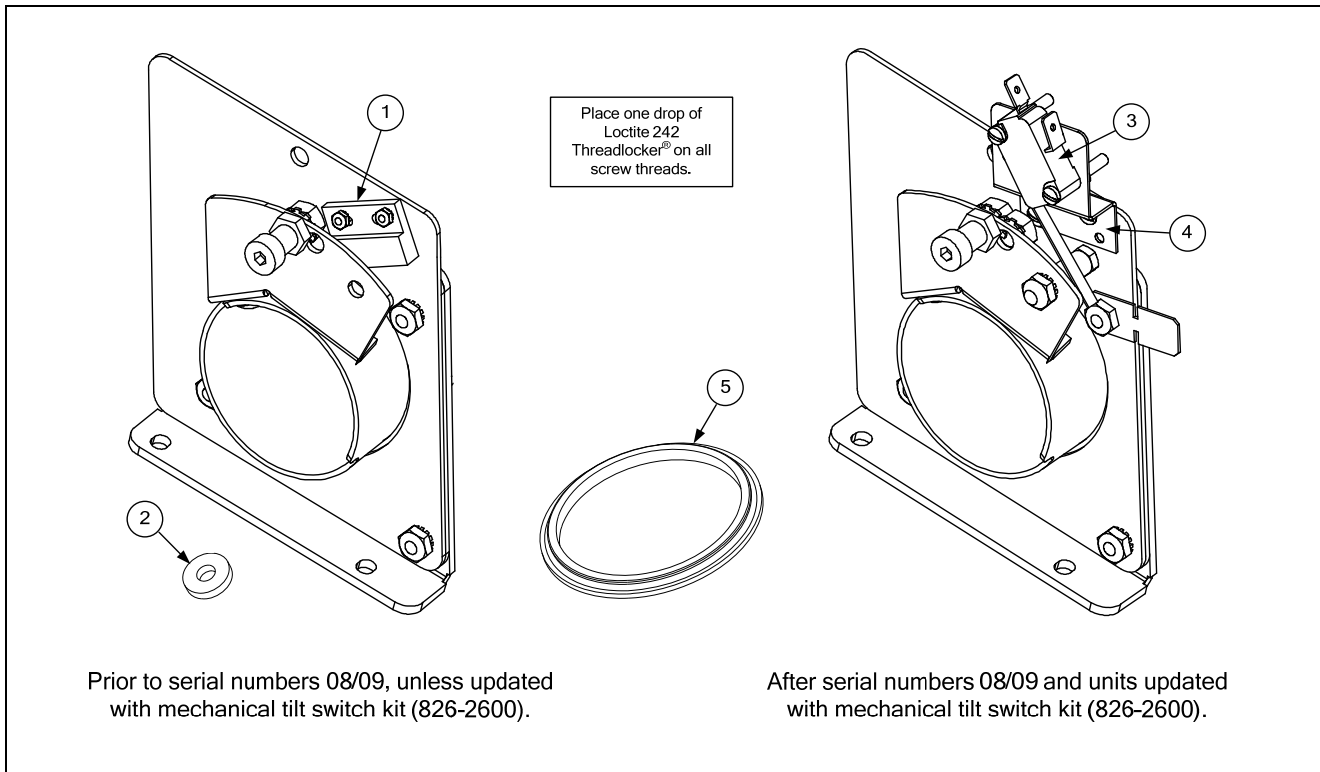

ITEM	PART #	COMPONENT
1**	106-5876SP	Sensory Assembly, Magnetic Positioning
2**	810-3007	Magnet, Magnetic Positioning (<i>used with Item 1</i>)
*	826-2600	Tilt Switch Kit, Mechanical (<i>includes Items 3 and 4</i>)
3***	807-4742	Tilt Switch, Mechanical, Hi-Temp/Long Lever
4***	220-5352	Bracket, Mechanical Tilt Switch
5	810-2993	Bushing, Element Tube, Teflon

* Not illustrated.

** Fryers with serial numbers prior to 08/09, unless already updated with mechanical tilt switch kit (826-2600).

*** Fryers with serial numbers after 08/09 or older units updated with mechanical tilt switch kit (826-2600).

2.4.3 4-Lane Controller

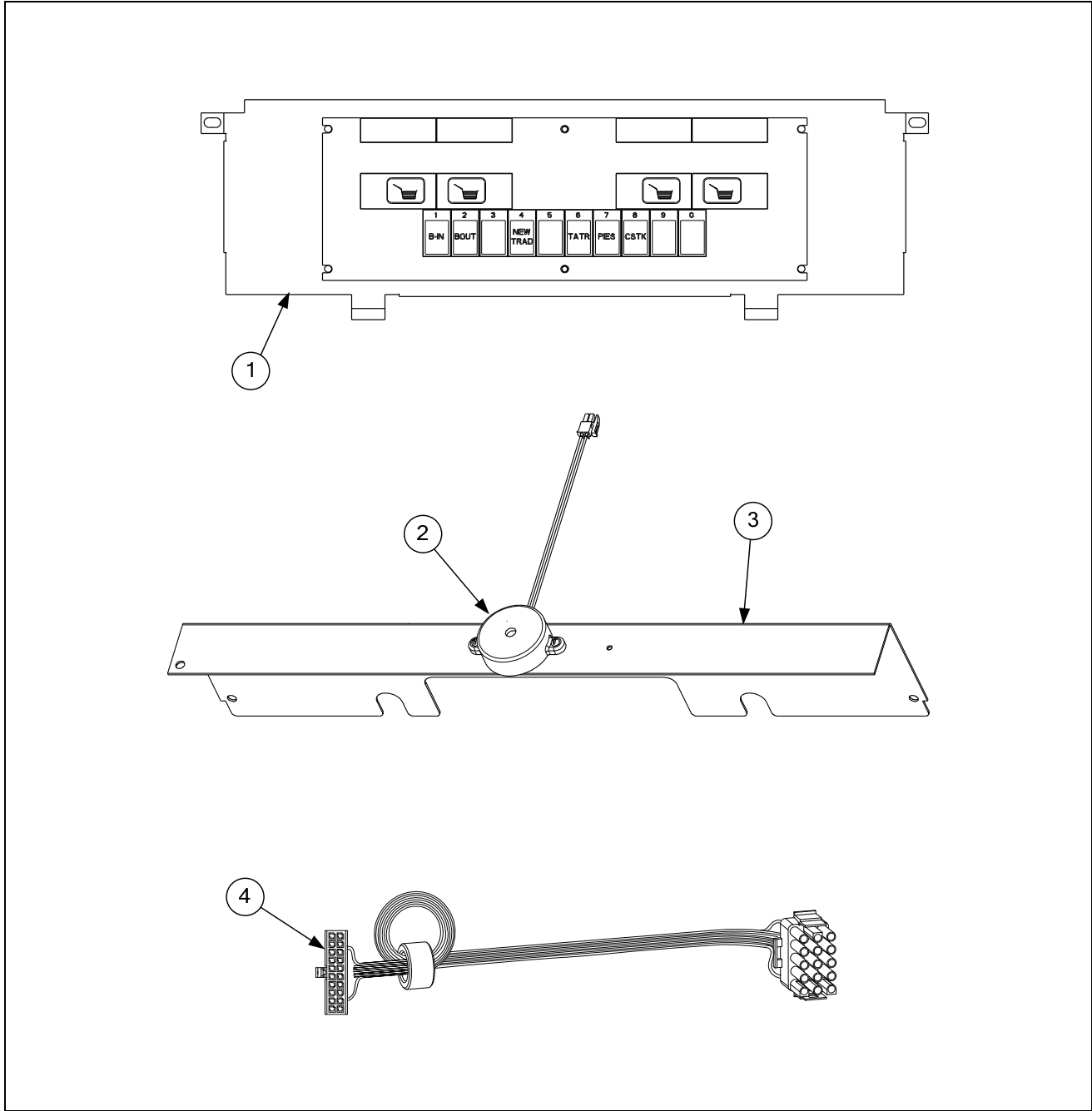

ITEM	PART #	COMPONENT
1	826-2859	Wingstreet 4-lane Computer
2	810-3141	Sound Device
3	220-4284	Guard
4	807-4199	SMT Cable

2.4.4 Contactor Box

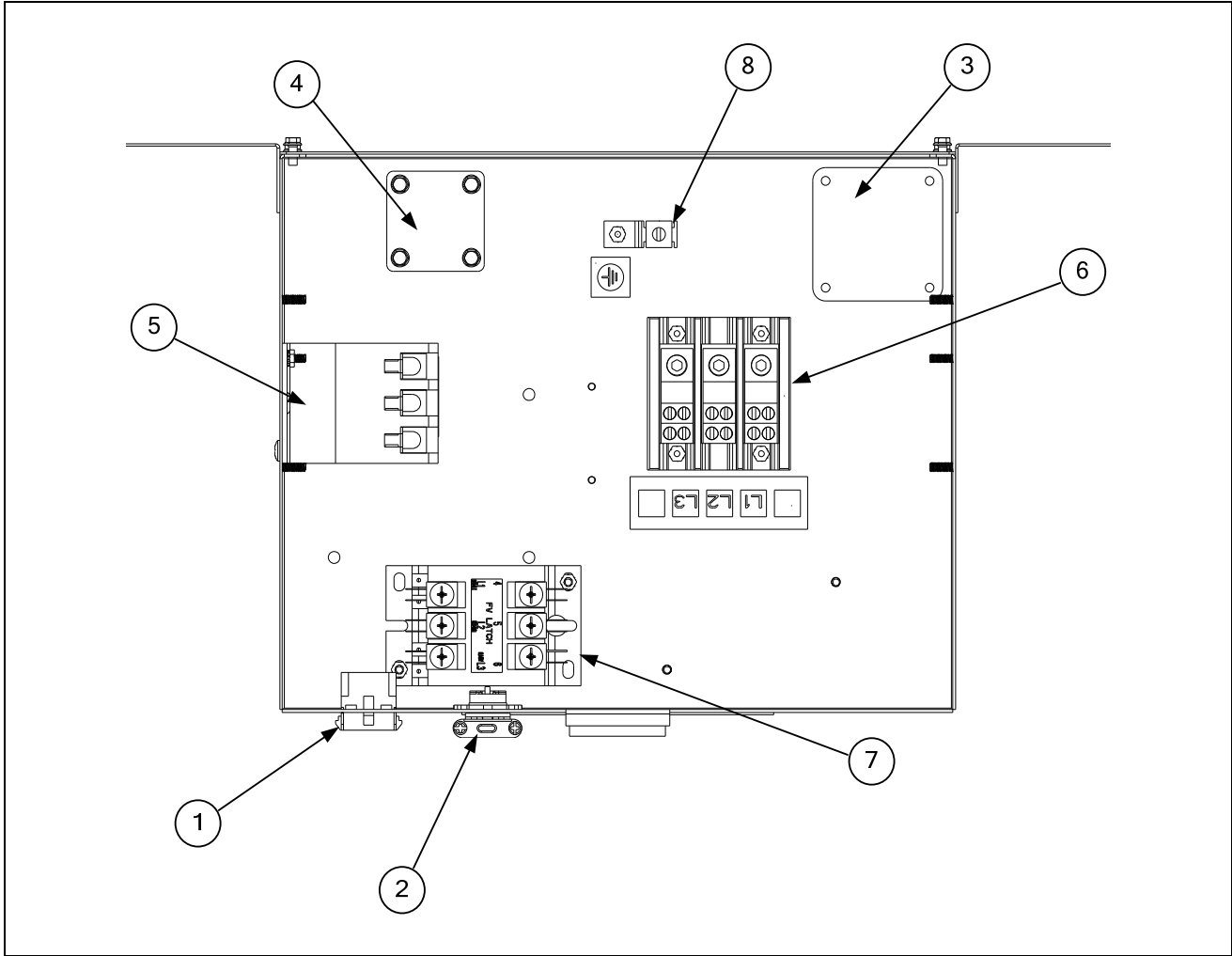

ITEM	PART #	COMPONENT
1	108-0159	Harness Assembly, FV Contactor Box Control
2	108-0158	Harness Assembly, 208/240 Contactor Box Power
*	108-1047	Harness Assembly, Contactor Box Power, CE
3	220-4489	Plate, Contactor Box Cordset Cover
4	220-6878	Plate, Power Cord Cover
5	807-2284	Heat Contactor, 50 Amp Mechanical, 24V Coil
6	807-3970	Block, 3 Pole, 600V, 175 Amp Terminal
7	810-1202	Latch Contactor, 3 Pole, 600V, 40 Amp
8	807-0070	Ground Lug Terminal
*	106-8744	Harness Assembly, MDI Contactor Box, 6 Pin (below Item 5)
*	106-8745	Harness Assembly, MDI Contactor Box, 9 Pin (below Item 5)
*	807-4658	Cordset, 4GA, 3 Phase, 4 Wire with Plug with Strain Relief
*	807-3835	Cable, 5-wire, export

* Not illustrated.

2.4.5 Component Box

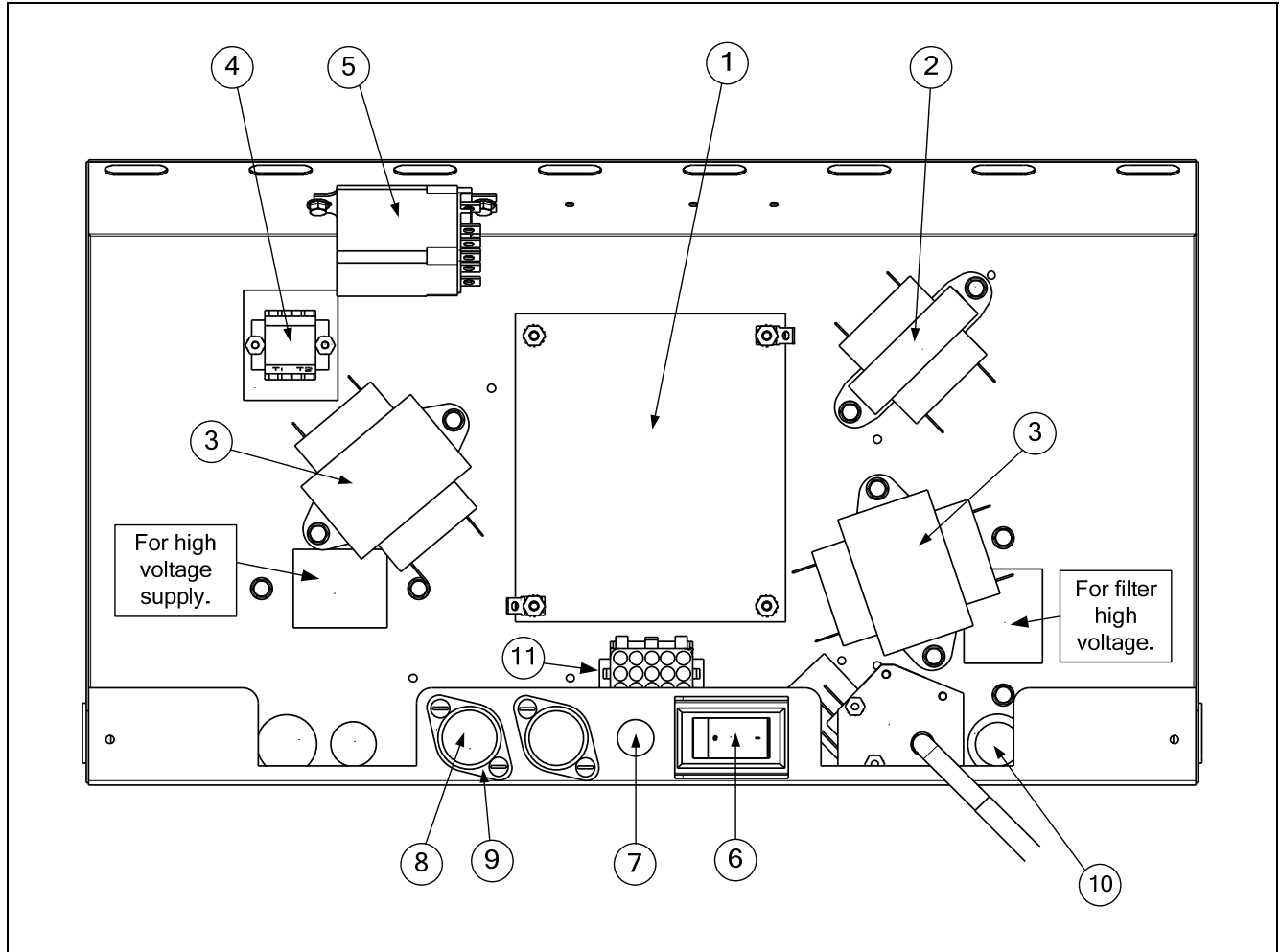

ITEM	PART #	COMPONENT
	106-9227	Component Box, 208/240V FV
	108-1043	Component Box, 208/240V FV CE
1	826-2260	PCB Assembly, Interface Board, SMT
2	807-0979	Transformer, 208/240/12VAC, 50/60 Hz, 43 VA
*	807-2191	Transformer, 208/230/240/12V (30VA) CE
*	807-1597	Fuse, 3 Amp, on 807-2191 Transformer
3	807-0680	Filter Transformer, 208/240/24V, 50/60 Hz, 20 VA
*	807-2180	Transformer, 208/240/24V (50VA) CE
4	810-1164	Block, 1 PLC Screwless Terminal
5	807-0670	Filter Relay, Midtex DPDT 24V
*	807-0012	Relay, 18 amp CE
6	807-4036	Switch, Power
7	810-2446	Plug, .50 Heyco Double "D"
8	807-2278	Fuse, 20 Amp
9	807-0922	Holder, Buss Fuse HPS
10	810-0045	Bushing, .875 Diameter Hole, 11/16
11	106-5750SP	Harness Assembly, Controls

2.5 Wiring

2.5.1 Contactor Box Harness Assembly, 12-Pin (Control)

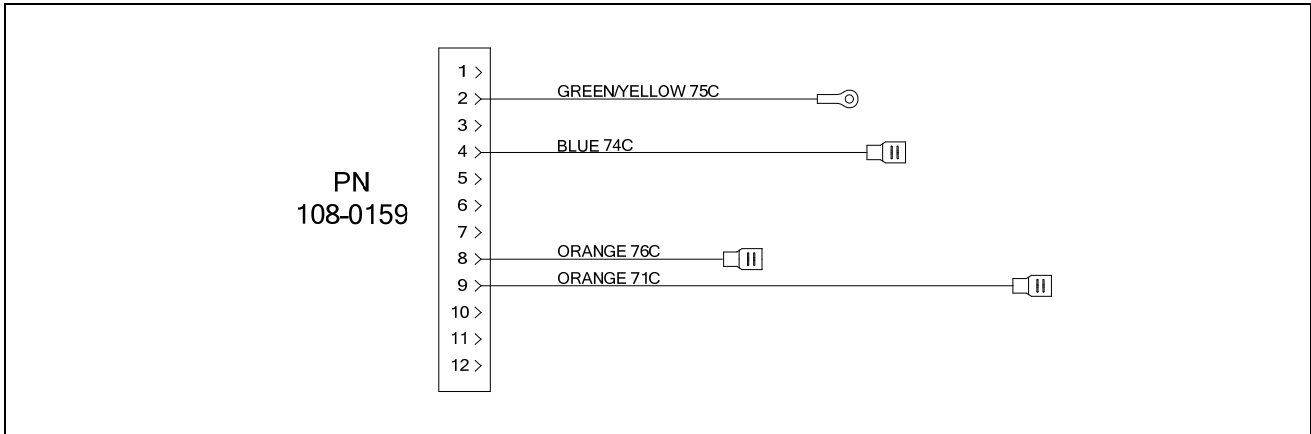

2.5.2 Contactor Box Harness Assembly, MDI, 6-Pin (Left Element)

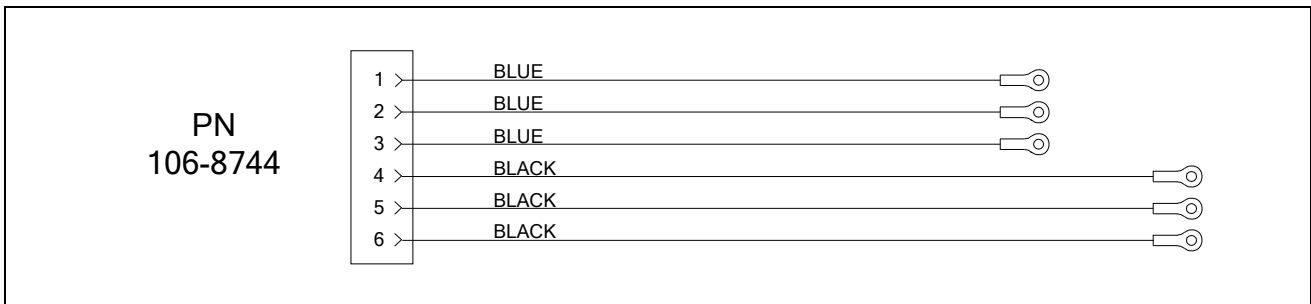

2.5.3 Contactor Box Harness Assembly, MDI, 9-Pin (Right Element)

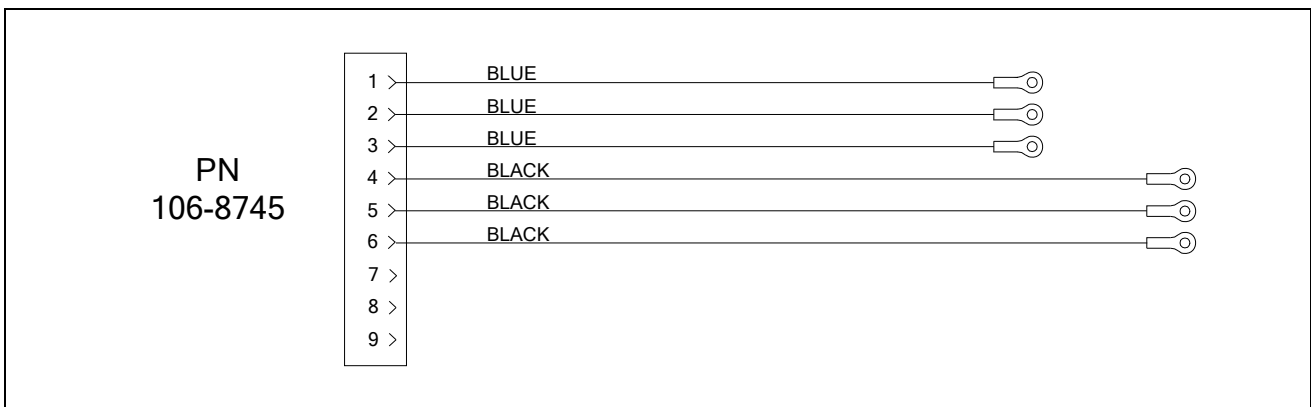

2.5.4 Component Box to Filter Pump Harness

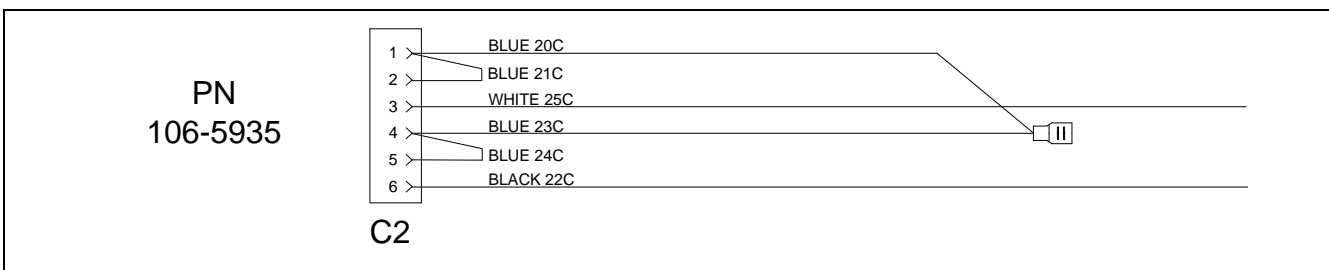

2.5.5 Main Wiring Harnesses

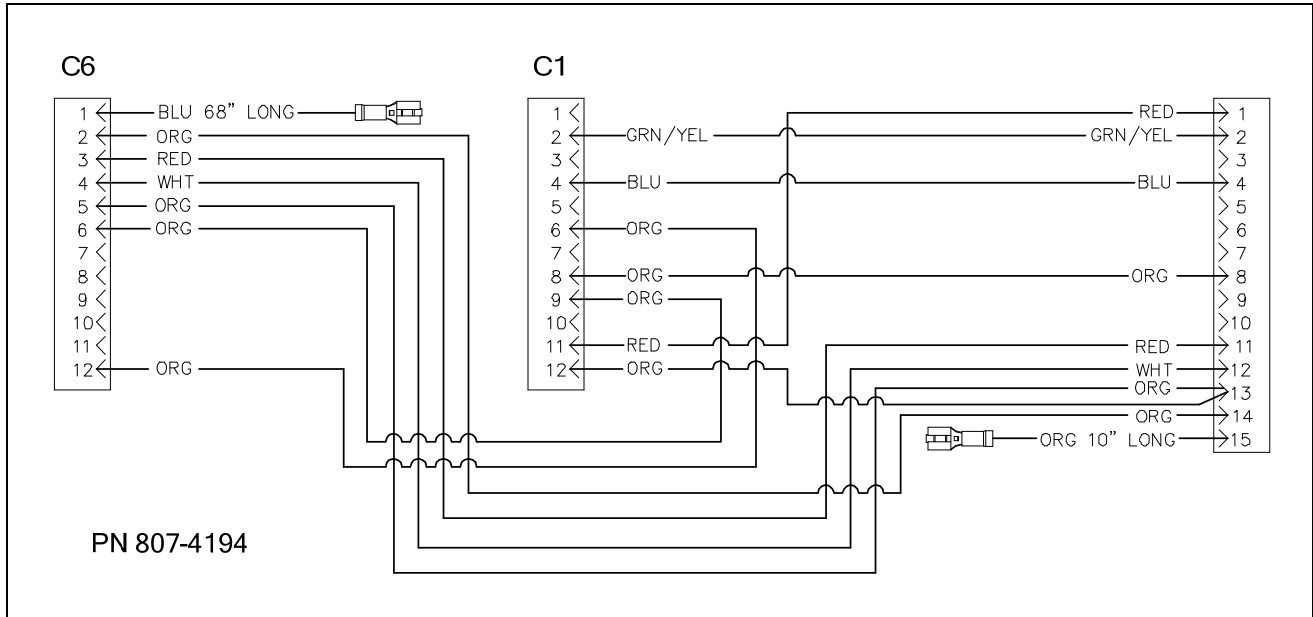

2.5.6 Component Box and Filter Pump

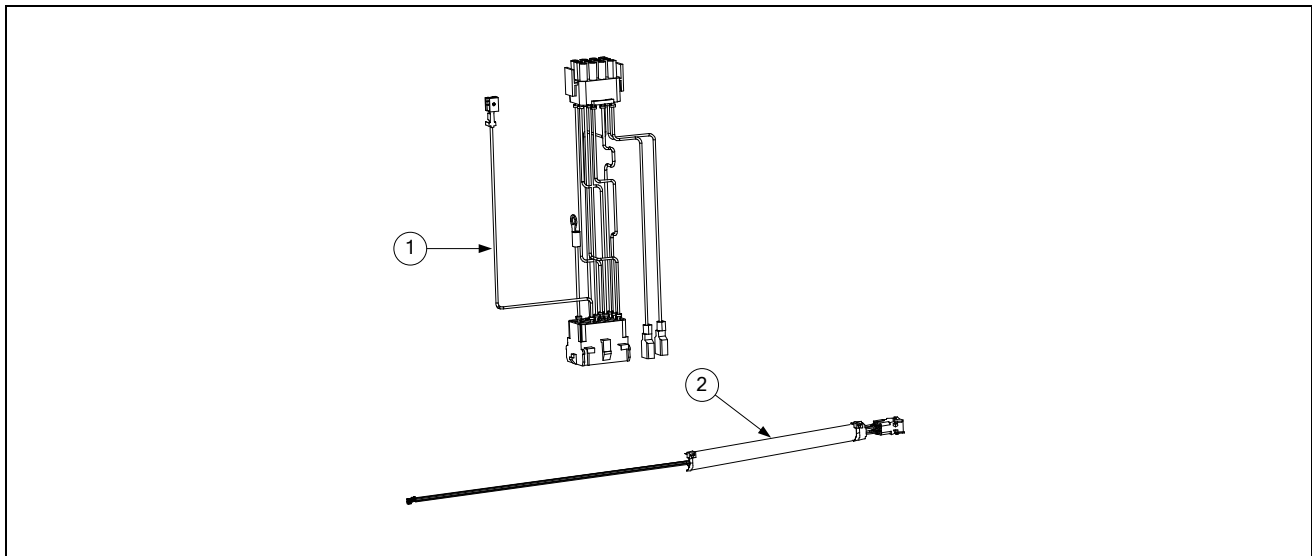

ITEM	PART #	COMPONENT
1	106-5750SP	Full Vat Control Harness J4 to J2 (Standard)
2	106-5935SP	Filter Pump C2 to Component Box Wiring Harness

2.6 Filtration System Components

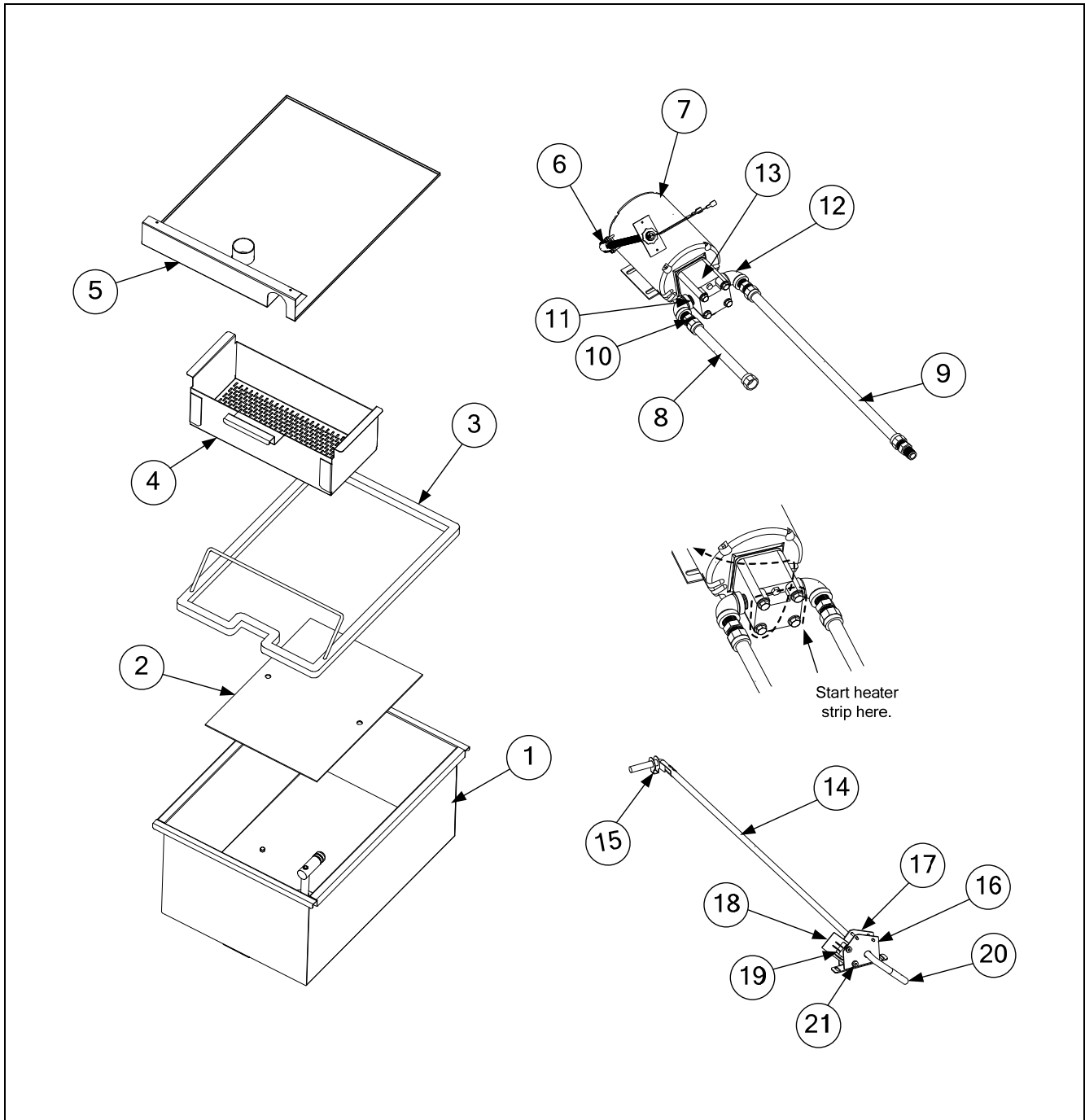

2.6 Filtration System Components (cont.)

ITEM	PART #	COMPONENT
	106-9313	Filter Pan Assembly
1	823-7086	Filter Pan
2	220-4446	SanaGrid Filter Screen
3	810-3414	Ring, Wireform Holddown
4	824-1957	Crumb Basket
*	826-1392	O-ring (<i>Pkg. of 5; used with Item 1</i>)
5	823-6714	Lid, Filter Pan
6	106-5906	Wiring Harness Assembly, Filter Pump, 208/240V
*	106-5912SP	Heater Strip Assembly, 18" 240V 25W
7	826-1756	Motor, 208V 50/60 Hz (<i>Gasket, 816-0093, included.</i>)
*	826-1270	Motor, 230V 50/60 Hz (<i>Gasket, 816-0093, included.</i>)
8	810-1055	Flexline, 5/8" OD x 11.5" long
9	810-1068	Flexline, 5/8" OD x 21.5" long
10	810-1668	Adaptor, Male 5/8" OD x 1/2"
11	813-0022	Nipple, 1/2" x Close NPT
12	813-0062	Elbow, 1/2" Black 90°
13	826-2795	Pump, Viking 4 GPM (<i>Gasket, 816-0093, included.</i>)
	106-9255	Oil Return Handle
14	810-3615	Rod, Rear Flush Oil Return
15	809-0601	Clip, Clevis, Rod End
16	220-5218	Bracket, Rod Retainer
17	108-0078	Bracket Stud Assembly
18	816-0220	Insulation, Switch
19	807-2103	Microswitch (Straight Lever)
20	810-0677	Grip, Drain Handle, Yellow Vinyl
21	809-0237	Nut, 4-40 Keps Hex with Extended Tooth

* Not illustrated.

2.7 Frypot and Associated Parts

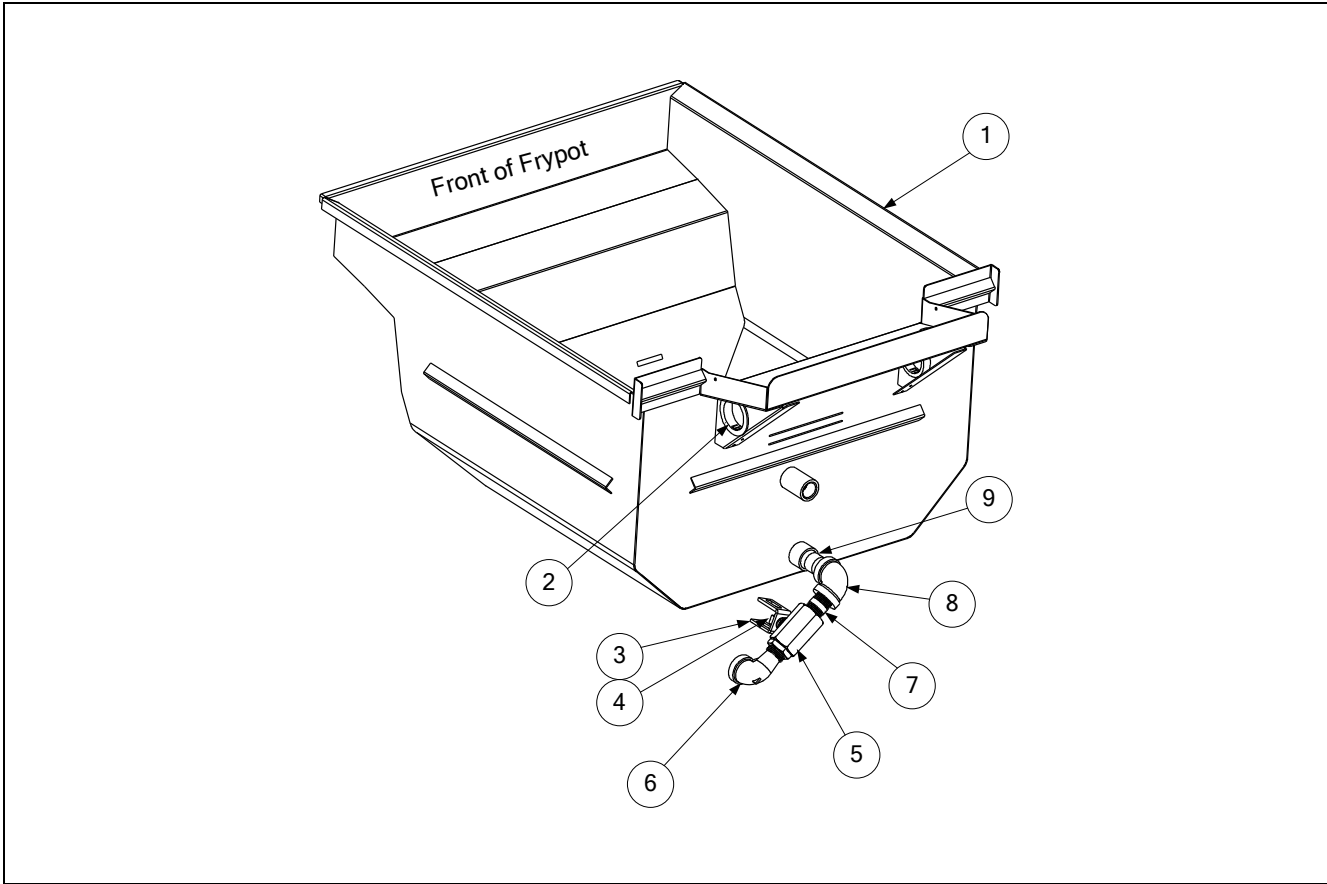

ITEM	PART #	COMPONENT
		Frypot Assembly
1	823-6706	Frypot
2	807-0128	Bushing, Insulating, Heyco
3	220-4564	Handle, Oil Return
4	900-2935	Retainer Nut, Oil Return Valve
5	810-0278	Valve, 1/2" Ball
6	813-0165	Elbow Street, 1/2" x 2" NPT
7	813-0087	Nipple, 1/2" x 1.50"
8	813-0062	Elbow, 1/2" 90°
9	813-0298	Nipple, 1/2" x 2" NPT
*	826-2454	Hi-limit Thermostat, 425°F
*	106-5876SP	Tilt Switch (See Page 2-6)

2.8 Wiring Connectors and Pin Connectors

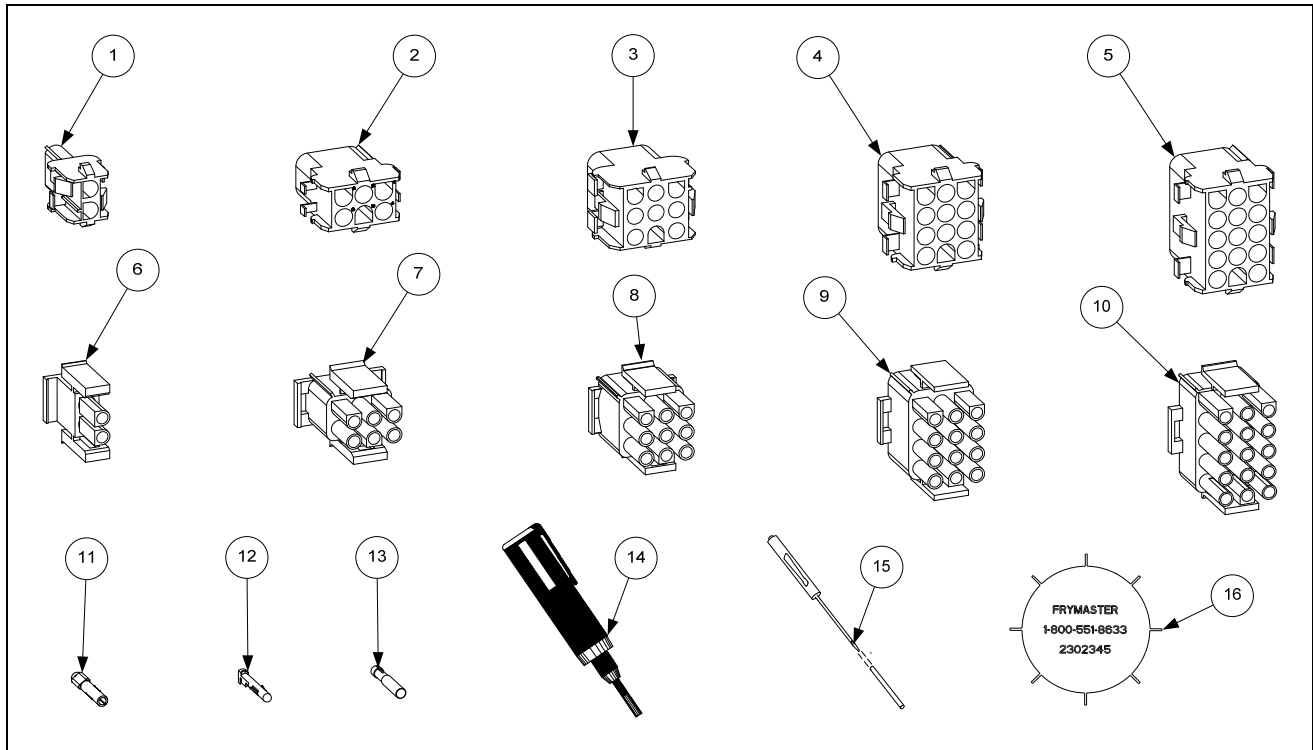

ITEM	PART #	COMPONENT
1	807-1068	2-Pin Female
2	807-2136	6-Pin Female, Hi Amp
3	807-2138	9-Pin Female, Hi Amp
4	807-0159	12-Pin Female
5	807-0875	15-Pin Female
6	807-1067	2-Pin Male
7	807-0157	6-Pin Male
8	807-0155	9-Pin Male
9	807-0160	12-Pin Male
10	807-0804	15-Pin Male
11	826-1341	Terminal, Female Split Pin (pkg. of 25)
12	826-1342	Terminal, Male Split Pin (pkg. of 25)
13	807-2518	Plug, Mate-N-Lock (Dummy Pin)
14	807-0928	Extract Tool Pin Pusher
15	806-4855	Pin Pusher Screwdriver Assembly
16	230-2345	SMT Pin Extractor
*	807-4660PK	SMT Pin Service Repair Kit

* Not illustrated.

2.9 Fasteners (Nuts, Bolts, Screws, Washers)

ITEM	PART #	COMPONENT
*	809-0514	Capscrew, 5/16-inch-18 NC Hex
*	809-0448	Clip, Tinnerman
*	826-1366	Nut, 4-40 Keps Hex (Pkg. of 25) (809-0237)
*	809-0247	Nut, 8-32 Keps Hex
*	826-1376	Nut, 10-32 Keps Hex (Pkg. of 10) (809-0256)
*	809-0766	Nut, 10-32 Keps Hex SS
*	809-0020	Nut Cap 10-24 NP
*	826-1359	Screw, 4-40 x 3/4-inch Slotted Round Head (Pkg. of 25) (809-0354)
*	826-1365	Screw, 6-32 x 3/8-inch Slot Head (Pkg. of 25) (809-0095)
*	809-0357	Screw, 6 x 3/8-inch Phillips Head NP
*	809-0359	Screw, 8 x 1/4-inch Hex Washer Head
*	809-0360	Screw, 8 x 3/8-inch Hex Washer Slot Head
*	826-1371	Screw, 8 x 1/2-inch Hex Head ZP (Pkg. of 25) (809-0361)
*	809-0518	Screw, 8-32 x 3/8-inch Hex Washer Slotted Head SS
*	826-1363	Screw, 8-32 x 1/2-inch NP (Pkg. of 25) (809-0103)
*	826-1360	Screw, 10-24 x 5/16-inch Round Slot Head ZP (Pkg. of 25) (809-0024)
*	826-1330	Screw, 10-32 x 3/8-inch Slot Head SS (809-0117)
*	809-1003	Screw, 10-32 x 3/8-inch Hex Trim Head SS
*	826-1375	Screw, 10-32 x 3/4-inch Hex Trim Head SS (Pkg. of 5) (809-0401)
*	826-1374	Screw, 10 x 1/2-inch Hex Head (Pkg. of 25) (809-0412)
*	809-0266	Screw, 10 x 1/2-inch Phillips Head ZP
*	826-1389	Screw, 1/4-20 x 3/4-inch Hex Head ZP (Pkg. of 10) (809-0131)
*	809-0184	Washer, #10 LK ZP
*	809-0191	Washer, Lock 1/4 Spring ZP
*	809-0193	Washer, Flat 1/4 Nylon
*	809-0194	Washer, Flat 5/16 ZP

* Not illustrated.



Frymaster, L.L.C
8700 Line Avenue, Shreveport, Louisiana 71106

TEL 1-318-865-1711

FAX (Parts) 1-318-219-7140

(Tech Support) 1-318-219-7135

PRINTED IN THE UNITED STATES

SERVICE HOTLINE
1-800-551-8633

819-6428
MAR 2013