



Models YSCFC 1824G, 2424G, and 24/24/15 Systems  
with Built-In Filtration

**YSCFC24G Series**  
**Flatbottom Gas Fryers**  
**Service & Parts Manual**

 **Frymaster**

 **Dean**



Frymaster Dean, a member of the Commercial Food Equipment Service Association, recommends using CFESA Certified Technicians.

PRINTED IN THE USA

**24-Hour Service Hotline**  
**1-800-551-8633**

[service@frymaster.com](mailto:service@frymaster.com)

[www.frymaster.com](http://www.frymaster.com)

FEBRUARY 2009  
\* 8196472 \*

**Please read all sections of this manual and retain for future reference.**

This product has been certified as commercial cooking equipment and **MUST** be installed by professional personnel as specified. Installation, maintenance and repairs should be performed by your **FRYMASTER DEAN FACTORY AUTHORIZED SERVICE CENTER**.

 **DANGER**

Do not store or use gasoline or other flammable vapors and liquids in the vicinity of this or any other cooking appliance.

 **DANGER**

Instructions explaining procedures to be followed **MUST** be posted in a prominent location in the event the operator detects a gas leak. This information can be obtained from the local gas company or gas supplier.

 **WARNING**

Improper installation, adjustment, alteration, service or maintenance can cause property damage, injury or death. Read the installation, operating and maintenance instructions thoroughly before installing or servicing this equipment.

 **DANGER**

Safe and satisfactory operation of your equipment depends on proper installation. Installation **MUST** conform with local codes, or in absence of local codes, with the National Fuel Gas Code, ANSI Z223.1; The Natural Gas Installation Code, CAN/CGA-B149.1; The Propane Installation Code, CAN/CGA-B149.2; or The latest edition of the National Electric Code, N.F.P.A. 70.

**NOTICE**

**IF, DURING THE WARRANTY PERIOD, THE CUSTOMER USES A PART FOR THIS ENODIS EQUIPMENT OTHER THAN AN UNMODIFIED NEW OR RECYCLED PART PURCHASED DIRECTLY FROM FRYMASTER DEAN, OR ANY OF ITS AUTHORIZED SERVICE CENTERS, AND/OR THE PART BEING USED IS MODIFIED FROM ITS ORIGINAL CONFIGURATION, THIS WARRANTY WILL BE VOID. FURTHER, FRYMASTER DEAN AND ITS AFFILIATES WILL NOT BE LIABLE FOR ANY CLAIMS, DAMAGES OR EXPENSES INCURRED BY THE CUSTOMER WHICH ARISE DIRECTLY OR INDIRECTLY, IN WHOLE OR IN PART, DUE TO THE INSTALLATION OF ANY MODIFIED PART AND/OR PART RECEIVED FROM AN UNAUTHORIZED SERVICE CENTER.**

 **DANGER**

The crumb tray in fryers equipped with a filter system must be emptied into a fireproof container at the end of frying operations each day. Some food particles can spontaneously combust if left soaking in certain shortening material. Additional information can be obtained in the filtration manual included with the system.

**⚠ DANGER**

The front ledge of the fryer is not a step. Do not stand on the fryer. Serious injury can result from slips or contact with the hot oil.

**⚠ WARNING**

Drawings and photos used in this manual are intended to illustrate operational, cleaning and technical procedures and may not conform to on-site management operational procedures.

**⚠ WARNING**

No structural material on the fryer should be altered or removed to accommodate placement of the fryer under a hood. Questions? Call the Frymaster Dean Service Hotline at 1-800-551-8633.

This equipment is to be installed in compliance with the basic plumbing code of The Building Officials and Code Administrators International, Inc. (BOCA) and the Food Service Sanitation Manual of the Food and Drug Administration.

**COMPUTERS (WHERE APPLICABLE)**

**FCC**

This device complies with Part 15 of the FCC rules. Operation is subject to the following two conditions:

1) This device may not cause harmful interference, and 2) This device must accept any interference received, including interference that may cause undesired operation. While this device is a verified Class A device, it has been shown to meet the Class B limits.

**CANADA**

This digital apparatus does not exceed the Class A or B limits for radio noise emissions as set out by the ICES-003 standard of the Canadian Department of Communications.

Cet appareil numérique n'émet pas de bruits radioélectriques dépassant les limites de classe A et B prescrites dans la norme NMB-003 édictée par le Ministre des Communications du Canada.

**⚠ DANGER**

**THIS PRODUCT CONTAINS CHEMICALS KNOWN TO THE STATE OF CALIFORNIA TO CAUSE CANCER AND/OR BIRTH DEFECTS OR OTHER REPRODUCTIVE HARM.**

Operation, installation, and servicing of this product could expose you to airborne particles of glasswool or ceramic fibers, crystalline silica, and/or carbon monoxide. Inhalation of airborne particles of glasswool or ceramic fibers is known to the State of California to cause cancer. Inhalation of carbon monoxide is known to the State of California to cause birth defects or other reproductive harm.

**⚠ WARNING**

Do not bang fry baskets or other utensils on the fryer's joiner strip. The strip is present to seal the joint between the fry vessels. Banging fry baskets on the strip to dislodge shortening will distort the strip, adversely affecting its fit. It is designed for a tight fit and should only be removed for cleaning.

# YSCFC Series Flatbottom Gas Fryers

## Service & Parts Manual

### TABLE OF CONTENTS

	PAGE #
<b>1. SERVICE PROCEDURES</b> .....	<b>1-1</b>
1.1 Functional Description.....	1-1
1.2 Accessing Fryers for Servicing.....	1-3
1.3 Cleaning Gas Valve Vent Tube.....	1-4
1.4 Adjusting Burner Manifold Gas Pressure.....	1-4
1.5 Calibrating the Thermatron Temperature Controller.....	1-5
1.6 Replacing Fryer Components.....	1-6
1.6.1 Remove/Replace Temperature Probe or High-Limit Thermostat.....	1-6
1.6.2 Removing/Replacing Rocker Switches.....	1-8
1.6.3 Replacing the Gas Valve.....	1-9
1.6.4 Replacing the Direct Spark Ignitor.....	1-9
1.6.5 Removing/Replacing Blower Assembly or Air Prover Switch.....	1-10
1.6.6 Replacing the Frypot.....	1-11
1.7 Troubleshooting and Problem Isolation.....	1-15
1.7.1 Ignition Failures.....	1-16
1.7.2 Improper Burner Functioning.....	1-17
1.7.3 Improper Temperature Control.....	1-19
1.7.4 Filtration Problems.....	1-19
1.7.5 Leakage.....	1-21
1.8 Troubleshooting Guides.....	1-22
1.8.1 Main Burner Malfunctions.....	1-22
1.8.2 Indicator Lights.....	1-23
1.9 Wiring Diagrams.....	1-24
1.9.1 Wiring for Common Cabinet Flatbottom without Boil Out.....	1-24
1.9.2 24/24 Filter Wiring.....	1-25
1.9.3 18/24 Common Cabinet Transformer Box.....	1-26

# YSCFC Series Flatbottom Gas Fryers

## Service & Parts Manual

### TABLE OF CONTENTS (cont.)

	PAGE #
2. PARTS LIST .....	2-1
2.1 Blower Assembly, Combustion Air .....	2-1
2.2 Burner Manifold and Related Components .....	2-2
2.3 Flue Caps, Top Caps, and Related Components .....	2-4
2.4 Cabinetry .....	2-6
2.5 Door Assemblies and Component Parts .....	2-8
2.6 Control Panels, Wireways, and Related Components .....	2-9
2.7 Oil Return and Suction Manifold .....	2-11
2.8 Filter Unit .....	2-13
2.9 Frypot, Drain, and Oil Return Components .....	2-14
2.10 Drain Valve and Components .....	2-16
2.11 Wiring Connectors, Pin Terminals, and Power Cords .....	2-17
2.12 Screws, Nuts, Fasteners .....	2-18

# YSCFC SERIES FLATBOTTOM GAS FRYERS

## CHAPTER 1: SERVICE PROCEDURES

---

### 1.1 Functional Description

YSCFC Series Flatbottom gas fryers contain a welded steel frypot (mild steel) with heat-transfer ducting on the frypot bottom for efficient heating of oil without scorching. A draft inducer draws air over the burners for combustion. Air movement directs the combustion products back and forth across the frypot bottom by means of a set of baffles, transferring the heat evenly. Cold air is prevented from entering the combustion chamber and cooling the oil during the coasting cycle.

Flames originate from orifices in three tubular burners positioned beneath the frypot. The diameter of the orifices differs for Natural (CE:G20/G25) and LP (CE:G31) gas as indicated in the table below.

<b>NON-CE (Altitudes of 2000 feet or less)</b>							
MODEL	INPUT (BTU)	GAS TYPE	ORIFICE [DRILL SIZE (MM)]	ORIFICE PART #	QTY	EQUIPMENT PRESSURE	
						MBAR	INCH W.C.
1824/24YSCFC	120	NAT LP	#34 (2.82) #50 (1.78)	810-2051 810-2317	3 3	10	4
						27.5	11

An electromechanical gas valve regulates gas flow to the manifold. YSCFC Series Flatbottom gas fryers are equipped with a 24-volt valve system and an electronic ignition system (direct spark ignition).

### Electronic Ignition Configuration

In units configured for electronic ignition, an ignition module connects to an ignitor assembly. The ignition module performs three important functions: it provides an ignition spark, supplies voltage to the gas valve, and proofs the burner flame.

The module contains a time delay circuit and a coil that activates the gas valve. The ignitor assembly consists of a spark plug and a flame sensor element.

At start-up the ON/OFF switch is placed in the "ON" position, supplying 115 VAC or 230 VAC, according to system configuration, to the Thermatron interface board. The voltage is stepped down via transformer to 24 VAC before entering the ignition module. If resistance in the temperature probe indicates the temperature in the frypot is below 150°F (66°C), the current flows through a melt cycle circuit where a switch alternately closes for approximately 4 seconds and opens for approximately 20 seconds. If the temperature is 150°F (66°C) or above, the current flows through a heat circuit, bypassing the timer switch. In either case, current is supplied to the other leg of the heat relay coil, which then closes an electronic switch in the 24 VAC circuit to provide current to the ignition module.

Circuitry in the ignition module sends 24 VAC current to the gas valve via a normally closed high-limit switch and a drain safety switch. Simultaneously, the module causes the ignitor to spark for up

# YSCFC SERIES FLATBOTTOM GAS FRYERS

## CHAPTER 1: SERVICE PROCEDURES

to 11 seconds to light the burner flame. A flame sensor verifies that the burner is lit by measuring the flow of microamps through the flame. If the burner does not light (or is extinguished), current to the ignition module is interrupted, preventing the main valve from opening, and the ignition module "locks out" until the power switch is turned "OFF", then back "ON".

A temperature probe monitors the temperature in the frypot. When the programmed setpoint temperature is reached, resistance in the probe causes the heat cycle circuitry in the controller to interrupt current flow through the heat relay. This in turn interrupts the 24 VAC to the ignition module, resulting in closure of the gas valve.

### Control Options

YSCFC Series Flatbottom gas fryers are equipped with Thermatron temperature controller. The fryer is turned on and off by means of a rocker switch and the temperature is set by adjusting a potentiometer. The Thermatron board is located in the wireway box behind the control panel, or in a component box inside the cabinet (depending on fryer configuration).

The Thermatron temperature controller operates by comparing resistance between the potentiometer setting and the temperature probe. If the resistance values don't match, an on-board relay energizes, sending voltage to the gas valve that supplies fuel to the burners. When the resistance values are equal, the on-board relay de-energizes, interrupting voltage to the gas valve, which stops the fuel flow.

Depending on the system configuration and destination, 115VAC controller boards are used.

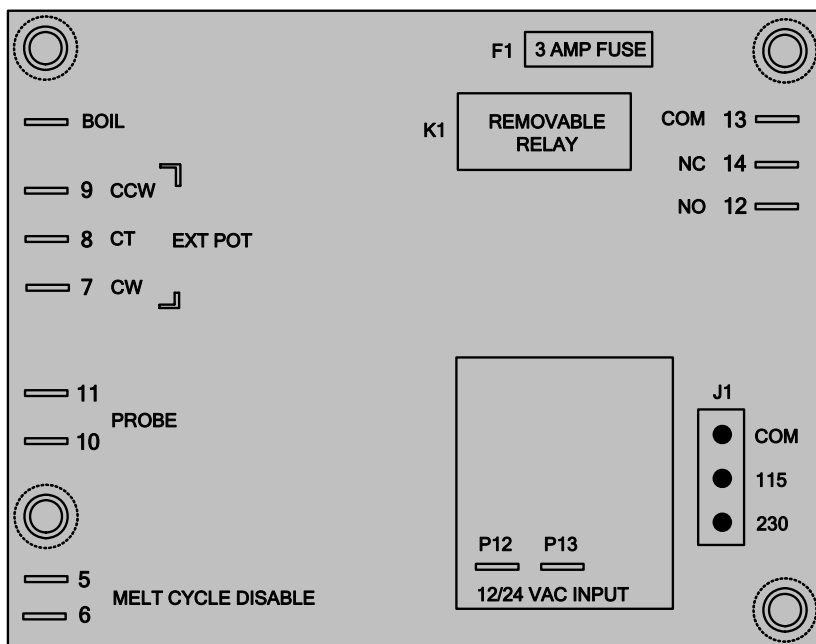

Line voltage enters the interface board at J1. The temperature controls (potentiometer) are connected to terminals 7, 8 and 9. The sensor probe circuit is connected to terminals 10 and 11. The high-limit and gas valve route through terminal 12. Terminals 5 and 6 are the melt-cycle disable circuit. The melt cycle is enabled unless terminals 5 and 6 are jumped out.

**Thermatron Controller Board**

# YSCFC SERIES FLATBOTTOM GAS FRYERS

## CHAPTER 1: SERVICE PROCEDURES

---

### Safety Components

All YSCFC Series Flatbottom gas fryers are equipped with a *high-limit thermostat*. In the event that the fryer fails to properly control the oil temperature, the high-limit thermostat prevents the fryer from overheating to flash point. The high-limit thermostat acts as a normally closed power switch that opens when exposed to temperatures above 410°F [(210°C) - CE] to 450°F [(232°C) - Non-CE]. CE and non-CE high-limits are not interchangeable.

Frying systems with built-in filtration are equipped with drain microswitches that disable the fryer if the drain valves are not completely closed. Opening a drain valve (i.e. filtering or draining the fryer) automatically opens the reset switch circuit. The drain valve must be fully closed prior to resetting the safety switch.

### 1.2 Accessing Fryers for Servicing



**Moving a fryer filled with cooking oil/shortening may cause spilling or splattering of the hot liquid. Follow the draining instructions included with the fryer before attempting to relocate a fryer for servicing.**

**NOTE:** Perform the following only if the fryer cannot be serviced in its installed location. Some of the following service procedures require the fryer to be connected to the gas and/or electrical supply.

1. Shut off the gas supply to the unit. Unplug the power cords. Remove any attached restraining devices.
2. Disconnect the unit from the gas supply.
3. Relocate the fryer for service accessibility.
4. After servicing is complete, reconnect the unit to the gas supply, reattach restraining devices, and plug in the electrical cords.



# YSCFC SERIES FLATBOTTOM GAS FRYERS

## CHAPTER 1: SERVICE PROCEDURES

---

### 1.3 Cleaning the Gas Valve Vent Tube (if applicable)

1. Set the fryer power switch and the gas valve to the "OFF" position.
2. Carefully unscrew the vent tube from the gas valve. **NOTE:** The vent tube may be straightened for ease in removal.
3. Pass a piece of wire through the tube to remove any obstruction. Remove the wire and blow through the tube to ensure it is clear.
4. Reinstall tube and bend so that the opening is pointing downward.

### 1.4 Adjusting Burner Manifold Gas Pressure

#### **WARNING**

**This task should be performed by qualified service personnel only.**

1. Ensure that the gas valve knob is in the "OFF" position.
2. Remove the pressure tap plug from the burner manifold.
3. Insert the fitting for a gas pressure-measuring device into the pressure tap hole.

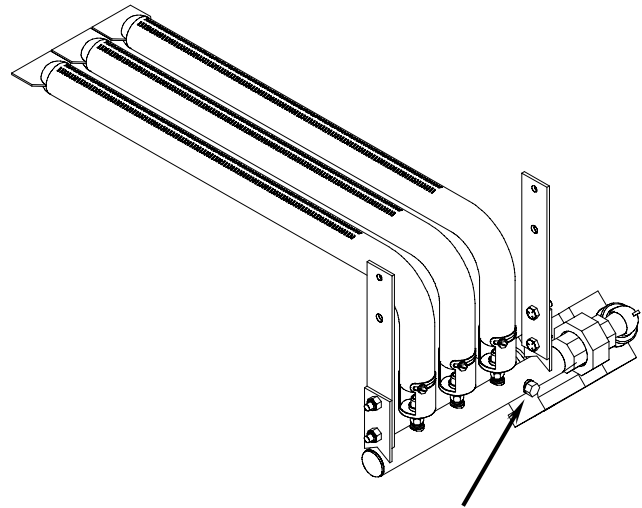

Remove pressure tap from burner manifold to check burner manifold pressure.

4. Place the gas valve in the "ON" position then place the fryer power switch in the "ON" position. When the burner lights and continues to burn, note gas pressure reading for correct pressure in accordance with the table on page 1-1.

# YSCFC SERIES FLATBOTTOM GAS FRYERS

## CHAPTER 1: SERVICE PROCEDURES

5. To adjust burner gas pressure, remove the cap from the gas valve regulator and adjust to correct pressure (arrow shown at right).
6. Place the fryer power switch and the gas valve in the "OFF" position. Remove the pressure-measuring device fitting from the pressure tap hole and reinstall the pressure tap plug.

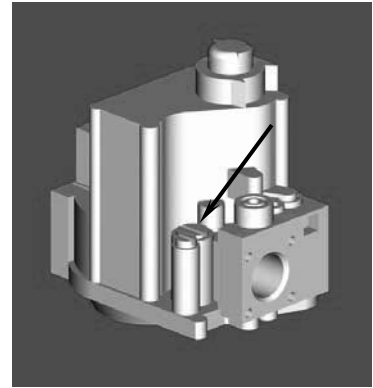

Non-CE Electronic Ignition Valve

### 1.5 Calibrating the Thermatron Temperature Controller

1. Ensure the fryer ON/OFF switch is in the "OFF" position. Fill the frypot to the proper oil-level line with cooking oil/shortening. If solid shortening is used, ensure that the shortening is properly packed and melted in the frypot before proceeding.
2. Place the fryer ON/OFF switch in the "ON" position. Set the Thermatron dial to 325°F (162°C).
3. Allow the oil/shortening to stabilize at setpoint temperature. This is evident when the burners have cycled on and off several times.
4. Insert a thermometer or pyrometer into the frypot within ½ inch (1.25 cm) of the probe tip. Ensure the tip of the thermometer/pyrometer does not touch the bottom or sides of the frypot.
5. If the temperature on the thermometer is higher or lower than 325°F (162°C), the dial is out of calibration.
6. Calibrate the dial by first loosening two setscrews in the dial (arrows). After loosening both setscrews, slowly turn the dial to match the temperature reading of the thermometer. Tighten each setscrew, ensuring the dial does not move on the shaft during tightening.
7. Allow burners to cycle on and off several times, then recheck oil temperature as described in step #5. If the Thermatron dial temperature matches the thermometer temperature, the controller is calibrated. If not, repeat step #7.
8. After calibration is complete, place the fryer power switch in the "OFF" position and disconnect the fryer from the electrical supply.

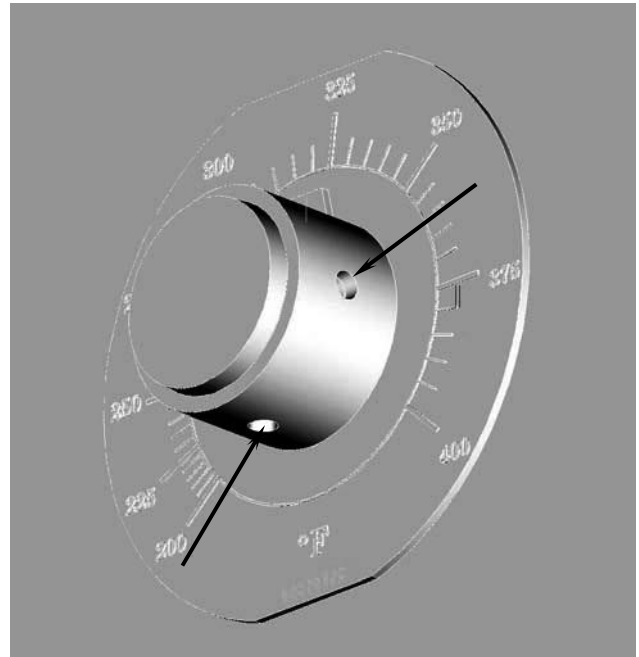

Loosen two setscrews in dial (arrows) to recalibrate controller.

# YSCFC SERIES FLATBOTTOM GAS FRYERS

## CHAPTER 1: SERVICE PROCEDURES

---

### 1.6 Replacing Fryer Components

#### 1.6.1 Remove/Replace Temperature Probe or High-Limit Thermostat

1. Disconnect the fryer from the electrical supply.
2. Allow the frypot to cool for 10 minutes before draining. Drain cooking oil/shortening from the frypot. Allow the frypot to cool completely before proceeding.
3. Remove the fryer door(s) for access to control panel screws. Lift door up, disengage rod from lower door bracket, and then remove door. (Current production models have spring-loaded door pins. Disengage bottom pin from the hinge, and then remove door.)
4. Remove the marine edge (where applicable) from the topcap.

5. Support the control panel and remove screws securing the panel to the wireway box. Remove the control panel.

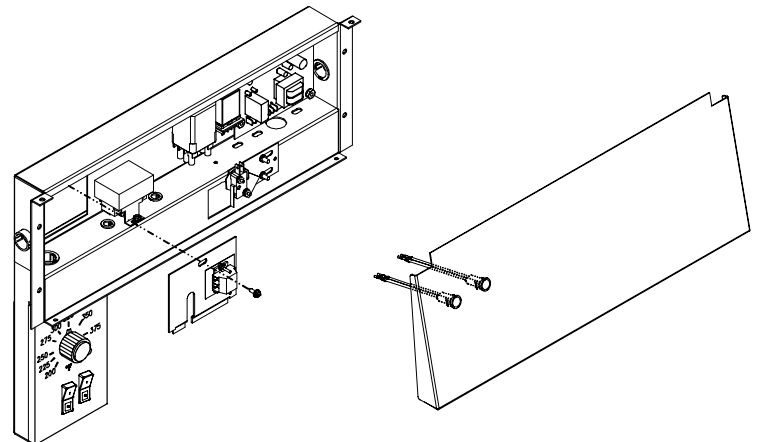

6. On units with indicator lights on the control panel, mark and unplug the wiring, and then remove the control panel.

7. Remove screw securing probe/high-limit access cover to wireway box. Remove access cover and set aside.

**NOTE:** Some systems have a wiring terminal block mounted on the access cover. Mark and disconnect the wiring to the terminal block before removing access cover.

# YSCFC SERIES FLATBOTTOM GAS FRYERS

## CHAPTER 1: SERVICE PROCEDURES

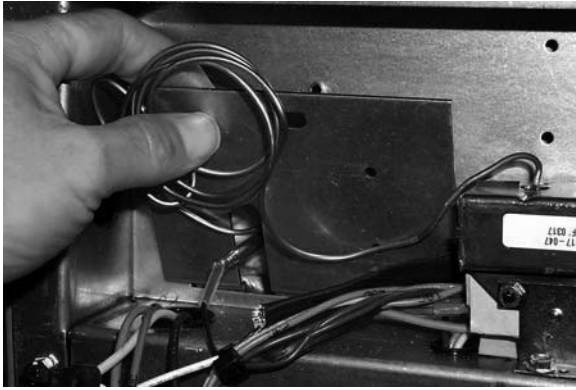

8. Remove the sensor bulb guard to access the probe and high-limit (pictured above). Current production systems have a sensor bulb clamp that must be removed prior to removing the probe or high-limit from the frypot (pictured top right).

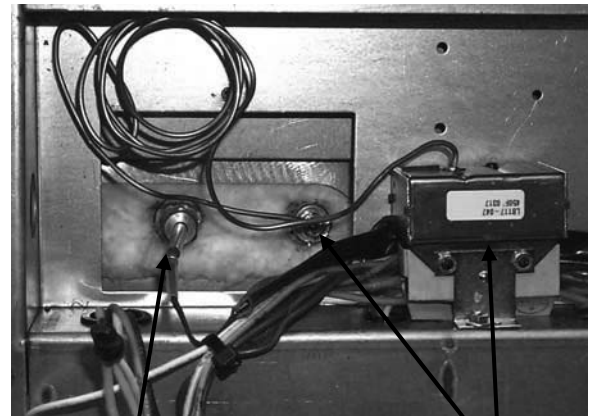

Temperature probe.

High-limit.

9. On the sensor bulb being removed, loosen and unscrew completely the compression nut, then the pass-through nut from the frypot. Carefully remove the sensor bulb from the frypot, being careful not to damage the remaining sensor bulb.

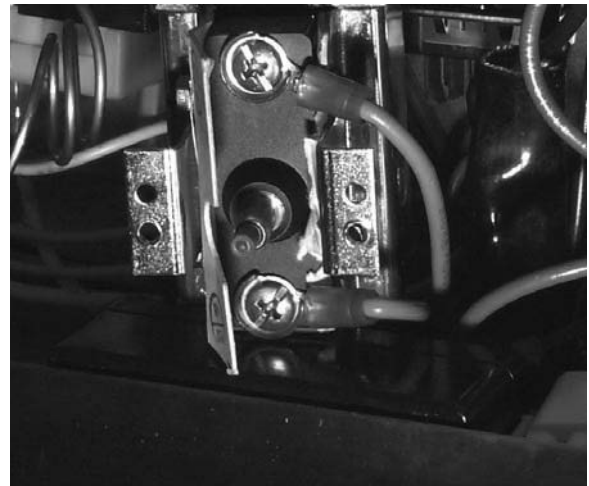

High-limit.

10. If removing the high-limit, remove the screws securing it to the wireway box. Mark and remove the wiring from the high-limit housing.

# YSCFC SERIES FLATBOTTOM GAS FRYERS

## CHAPTER 1: SERVICE PROCEDURES

- Reverse steps to install new temperature probe or high-limit. If reinstalling high-limit, ensure the capillary tube is properly routed around the temperature probe before tightening (see photo, Step #8). Reconnect wiring removed from defective high-limit.

**IMPORTANT (High-Limit):** When installing new high-limit, ensure the capillary tube and bulb are positioned properly with the mounting hardware installed prior to tightening the compression nut. **Once tightened, the capillary tube cannot be repositioned.**

**IMPORTANT (Temperature Probe):** When installing new temperature probe, ensure probe is positioned properly with the mounting hardware installed (current production systems), or 1/8" from frypot bottom (older systems), prior to tightening the compression nut. **Once tightened, the probe cannot be repositioned.**

In older fryers, ensure probe tip is 1/8" from frypot bottom for proper temperature sensing.

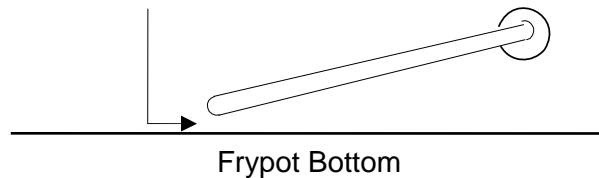

### 1.6.2 Removing/Replacing Rocker Switches

- Disconnect the fryer from the electrical supply.
- The switches are located on a control box inside the unit. Remove the screws securing the front panel of the control box. Do not allow the panel to hang by the switch wiring harness wiring; use some type of support.
- Depress the retaining clips (see illustration below) and push the switch out of the slot. If there is a switch-guard present, retain it for installation of the replacement switch.

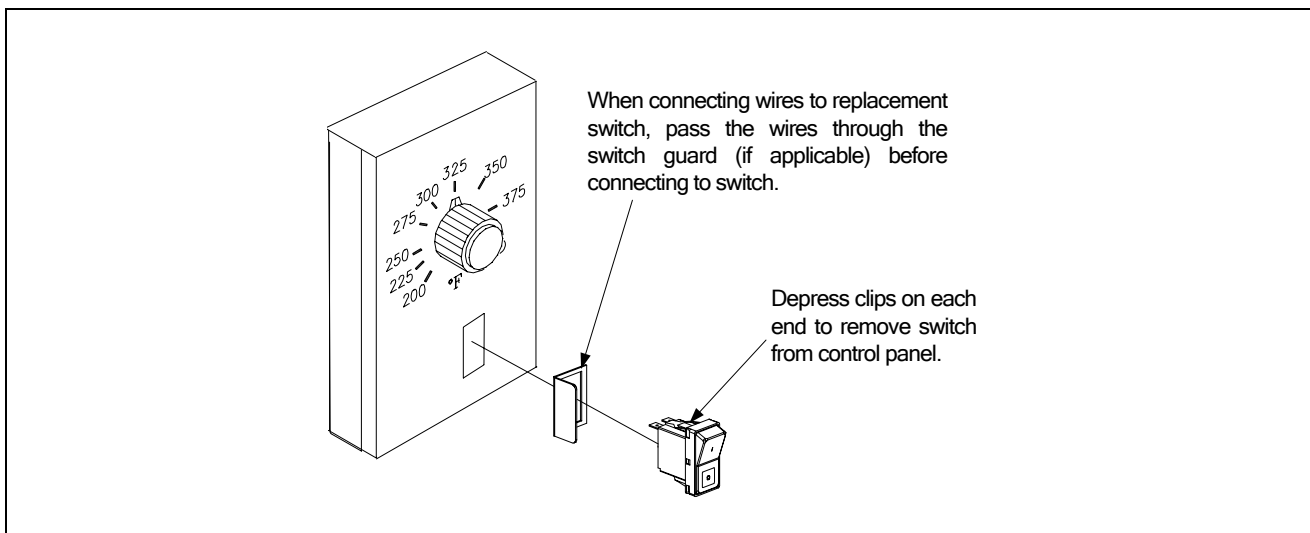

- Remove wires one at a time from the switch being removed and connect to the replacement switch until all wires are transferred.

# YSCFC SERIES FLATBOTTOM GAS FRYERS

## CHAPTER 1: SERVICE PROCEDURES

5. Reverse the above steps for reassembly.

### 1.6.3 Replacing the Gas Valve



**DANGER**

**Drain the frypot or remove drain valve handle to prevent accidental opening before proceeding further.**

1. Disconnect fryer from electrical and gas supplies.
2. Disconnect the wires from the gas valve terminal block, marking each wire to facilitate reconnections.
3. Remove the high-limit thermostat wire from the gas valve coil (CE only).
4. Remove gas lines and pipe union collars from the gas valve and remove the valve.
5. Remove the pipefitting from the old gas valve and install on the replacement valve, using Loctite PST567 or equivalent pipe thread sealant on threads. Do not apply sealant to the first two pipe threads. Doing so will clog and damage the gas valve.
6. Reverse steps 1-5 to install the replacement gas valve.

### 1.6.4 Replacing Direct-Spark Ignitor Assembly (Units with Electronic Ignition Only)

1. Remove the burner shield from the burner-box slots.
2. Disconnect sense wire and ignition cable from the ignitor.
3. Remove the mounting screw from the ignitor mounting-bracket and remove the ignitor.
4. Reverse the procedure to replace the ignitor assembly. Ensure the ignitor is properly positioned in relation to the center burner before tightening mounting screw.

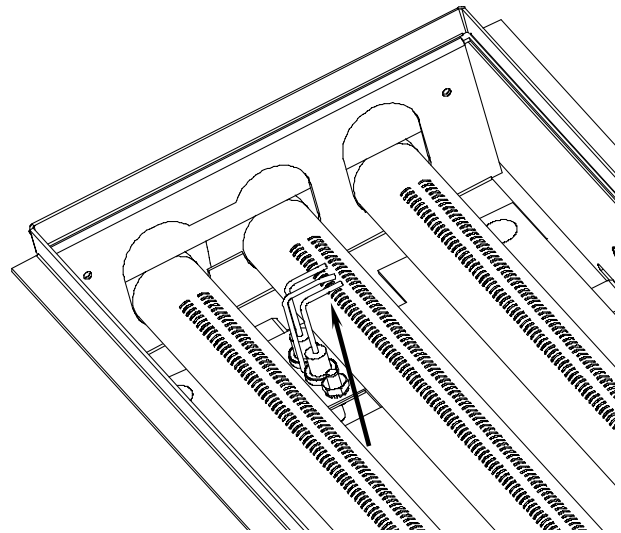

**NOTE:** The above procedure is applicable to fryers equipped with electronic ignition systems only.

Ensure ignitor is properly positioned (arrow) over the center burner prior to tightening the mounting screw.

# YSCFC SERIES FLATBOTTOM GAS FRYERS

## CHAPTER 1: SERVICE PROCEDURES

### 1.6.5 Removing/Replacing Blower Assembly or Air Prover Switch

1. Remove back panel. On systems with built-in filtration, use care not to damage the oil-return heat-tape wiring insulation when removing backs (multi-battered systems after 02/03 have two-piece back panels; remove both to access blower assembly).
2. Remove blower assembly by removing four screws (two screws securing the flue outlet to the firebox, and two screws securing the blower inlet housing to the firebox). Pull the assembly out of the slot and lower to the side. Do not remove the electrical connections at this time.
3. Remove junction box cover and mark and disconnect wiring to the switch. Unscrew fitting connecting sampling tube to air prover switch, being careful not to kink the tube. Remove two screws from bracket that attaches switch to junction box to remove switch. Install new air prover switch with bracket. Reattach sampling tube and wires removed from old switch and replace junction box cover.
4. If replacing blower, remove junction box cover, mark and disconnect each wire, and remove conduit fitting from junction box. Reinstall conduit fitting on new blower and reconnect wiring. Replace box cover.
5. Reverse steps 1 – 2 to reinstall blower assembly.



Multi-battered systems after have upper and lower back panels, which must be removed to access the blower assembly. (fryer at left shown with upper back panel removed).

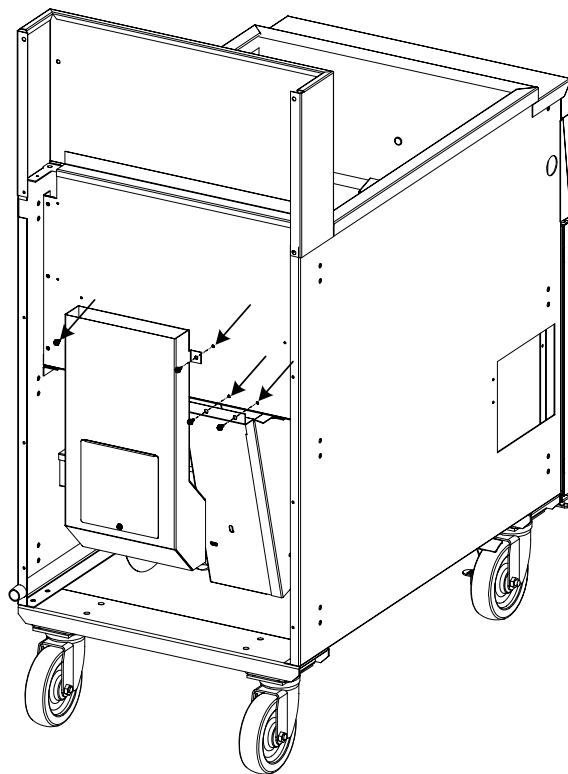
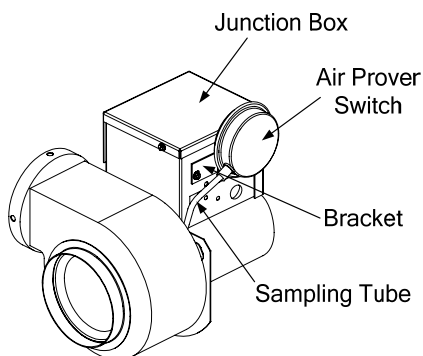

After removing screws (arrows), remove blower assembly from firebox by pulling outward.

# YSCFC SERIES FLATBOTTOM GAS FRYERS

## CHAPTER 1: SERVICE PROCEDURES

---

### 1.6.6 Replacing the Frypot

Unit should be at room temperature, disconnected from gas and electrical service, and empty of oil or shortening prior to beginning procedure.

#### 1.6.6.1 Frypot Baffle Inspection

1. Remove cabinet door(s) by holding door and lifting up on hinge pin. Current production model doors have spring-loaded pins that must be disengaged from the control panel and the bottom hinge. Remove marine edge (if applicable) by lifting up and off topcap and set aside.
2. The burner-tube retainer strip and burner tubes must be removed from the frypot/firebox being inspected. Remove the burner-tube shield and the burner-tube retainer from the burner-box and set aside. Lift the burner tubes up over each orifice and then pull outward to remove.

3. Disconnect the sense wire and ignition cable and remove the direct-spark ignitor assembly (with electronic ignition). Inspect frypot baffles for signs of burn-through or damage. If baffle burn-through or damage is visible, proceed to the next section. If not, and no further service to frypot/firebox is required, reverse the above steps to reassemble the fryer.

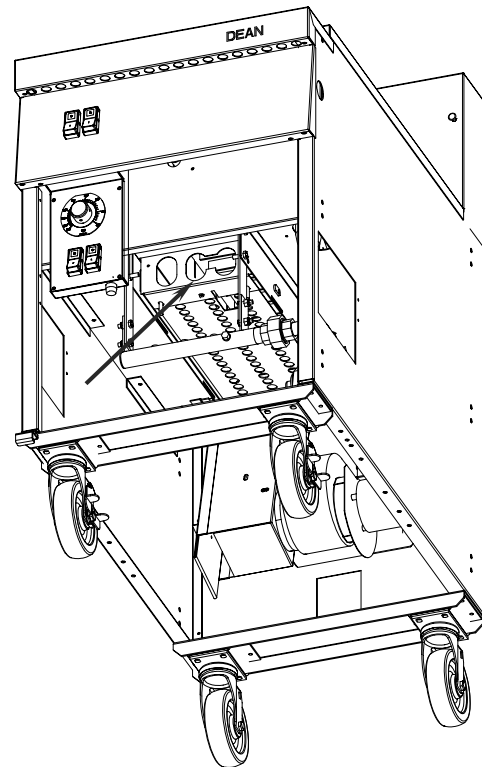

Inspect frypot baffles through burner tube opening (arrow) for signs of burn-through or damage.



# YSCFC SERIES FLATBOTTOM GAS FRYERS

## CHAPTER 1: SERVICE PROCEDURES

### 1.6.6.2 Frypot/Firebox Removal/Replacement Procedure

1. Perform Procedure 1.6.5, *Removing/Replacing Blower Assembly or Air Prover Switch*, Steps 1 – 4.
2. Disconnect the union at the gas valve. Remove four bolts connecting the burner manifold brackets to the burner box. Remove the burner manifold assembly and set aside.
3. Mark and disconnect the drain-valve microswitch wiring. Remove elbow or drain-tee assembly, and then remove the drain valve/microswitch assembly.

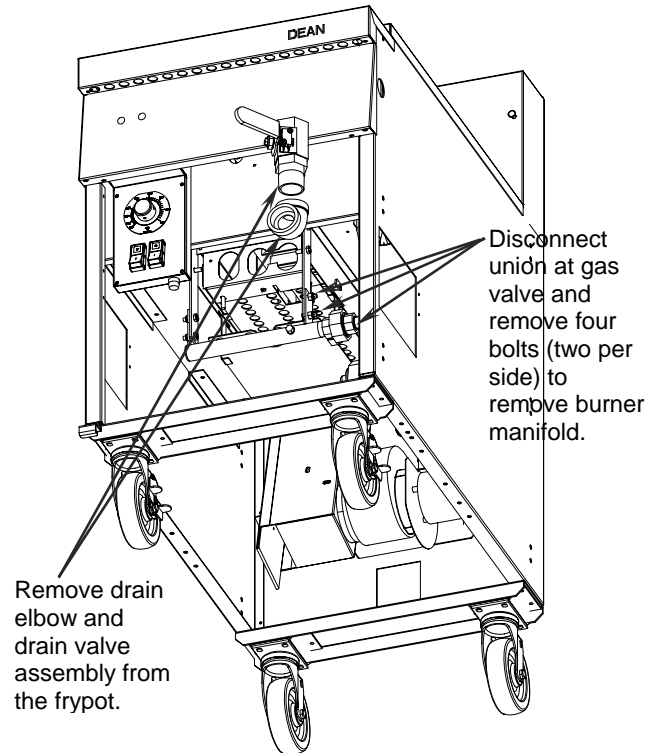

Disconnect union at gas valve and remove four bolts connecting burner manifold brackets to firebox and drain valve assembly from frypot.

4. Remove two screws from control panel and lower, using care not to stretch or distort indicator light wiring (if applicable). If control panel is equipped with indicator lights, mark and disconnect wiring and set control panel aside.

**If equipped with indicator lights, use a pin-pusher to remove pins from main-harness connector, and then remove control panel.**

5. Perform Procedure 1.6.1, *Remove/Replace Temperature Probe or High-Limit Thermostat*, Steps 7 – 11.

# YSCFC SERIES FLATBOTTOM GAS FRYERS

## CHAPTER 1: SERVICE PROCEDURES

---

6. Remove two screws securing topcap to wireway box. Remove topcap. Remove four screws securing wireway box to fryer cabinet (arrows) and carefully lower wireway box out of the way. Use care not to stretch or distort the wiring.
7. Remove two screws from the firebox heat shield (arrows), remove heat shield and set aside.

**NOTE: Steps 8 and 9 must be performed prior to frypot removal, especially on systems with built-in filtration. Failure to perform these steps will make frypot removal extremely difficult, and cause possible damage to firebox components during removal.**

8. Remove the burner box baffle by pushing the baffle up into the burner box until the baffle studs are clear of the slots. Tilt the baffle at an angle and remove it from the burner box.
9. Remove screws (two) securing the flame spreader to the burner box. Allow the spreader to drop down to clear the frypot baffles.

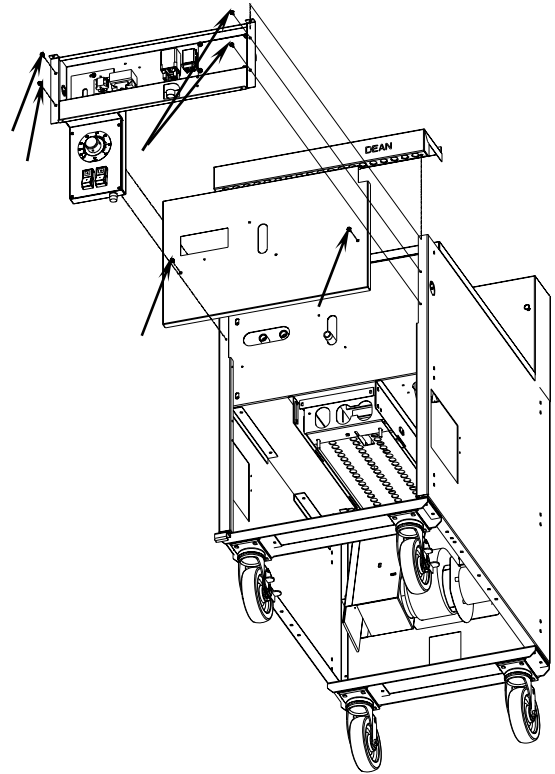

Remove topcap, wireway box and front heat shield to access firebox and frypot.

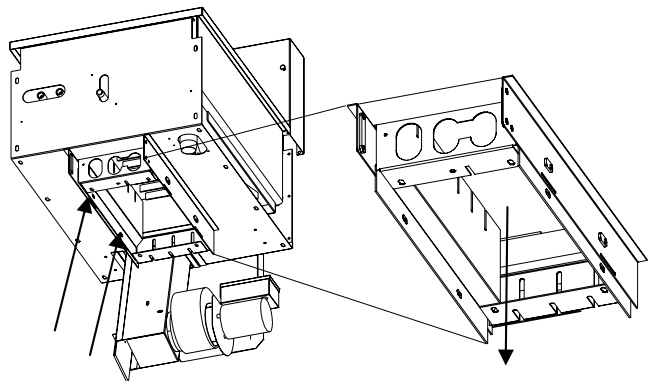

After removing burner-box baffle, remove screws (two) securing the flame spreader to the burner box. Allow the flame spreader to drop down in the burner box to clear the frypot baffles. Repeat for both sides.

## YSCFC SERIES FLATBOTTOM GAS FRYERS CHAPTER 1: SERVICE PROCEDURES

10. Remove firebox back, along with insulation from back of frypot. From the rear of the unit, use a prying bar to carefully pry the top assembly from the frypot and cabinet frame (single units only), and set aside. (The top assembly is secured to the frypot with high-temp silicone sealant.) On systems, remove individual pieces on the frypot being removed.

11. Pull the frypot back and up to remove. On fryers with built-in filtration systems, ensure the front oil-return inlet is clear of the firebox front before lifting frypot out of cabinet.

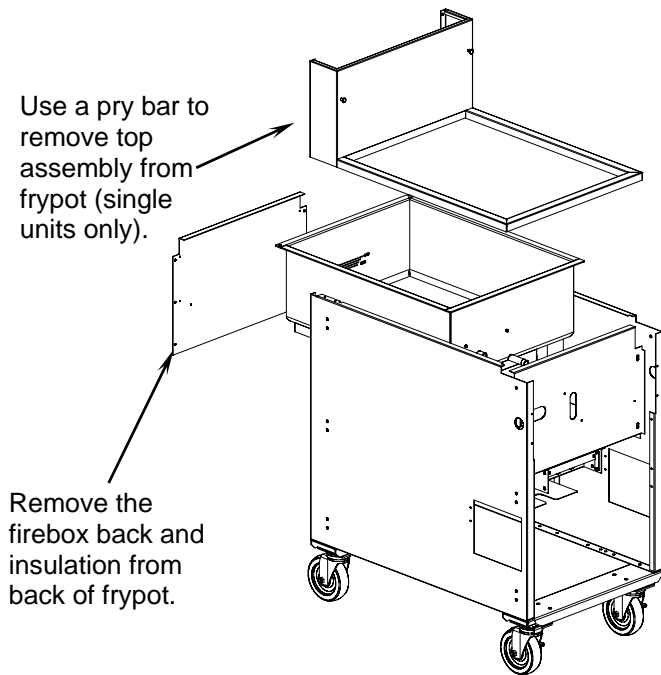

### If the Firebox Requires Replacement:

12. Remove screws (12) securing the firebox to the cabinet braces (arrows). Lift the firebox assembly back and up to remove from cabinet.



Remove screws (arrows) securing the firebox to the cabinet.

# YSCFC SERIES FLATBOTTOM GAS FRYERS

## CHAPTER 1: SERVICE PROCEDURES

13. Install new firebox into cabinet. Replace screws (12) removed during removal of the old firebox. Use spray adhesive (Zep Aero Tac High-Strength Spray Adhesive or equivalent) to install new insulation in firebox bottom as shown. The insulation must not go above the top of the burner-box center flange.

**NOTE:** Ensure the strip of insulation is properly affixed to the front blower-housing flange (arrow) prior to installing frypot. Failure to install the insulation strip will result in frypot-baffle burnout, blower damage and fryer malfunction, and will void all applicable warranties.

14. Install new frypot, using care not to damage the firebox insulation. Ensure the blower-housing insulation strip remains in place after installing the new frypot (arrow).

Reverse the above steps to reassemble the fryer. Use high-temp silicone to re-install the top assembly (single fryers) or joiner strips, flue caps, etc. (systems).



Install new insulation in firebox using spray adhesive, ensuring good contact between insulation and metal surfaces.



Ensure blower-housing insulation strip remains in place after installing the new frypot (arrow).

## 1.7 Troubleshooting and Problem Isolation

This section is intended to provide technicians with a general knowledge of the broad problem categories associated with this equipment, and the probable causes of each. With this knowledge, the technician should be able to isolate and correct any problem encountered.

Problems you are likely to encounter with YSCFC Series Flatbottom fryers can be grouped into five categories:

1. Ignition failures
2. Improper burner functioning
3. Improper temperature control
4. Filtration problems
5. Leakage

# YSCFC SERIES FLATBOTTOM GAS FRYERS

## CHAPTER 1: SERVICE PROCEDURES

---

The probable causes of each category are discussed in the following sections. Troubleshooting guides are included in **Section 1.8** to assist in identifying some of the more common problems.

### 1.7.1 Ignition Failures

Ignition failure occurs when the ignition module fails to sense a flame within the 11-second time delay period and locks out. Turn the fryer off, locate and correct the problem, then turn fryer back on to clear the module lock.

There are three primary reasons for ignition failure, listed in order of probability:

1. Problems related to the gas and/or electrical power supplies.
2. Problems related to the electronic circuits.
3. Problems related to the gas valve.

#### Problems Related to the Gas and/or Electrical Power Supplies

The main indicator is that an entire battery of fryers fails to light. Verify that the quick disconnect hose is properly connected, the fryer is connected to power, the main gas supply valve is open, and the circuit breaker for the fryer electrical supply is not tripped. Some fryers are equipped with a fryer reset-switch that must be reset each time the fryer is turned off.

#### Problems Related to the Electronic Circuits

If gas and electrical power are supplied to the fryer, the next most likely cause of ignition failure is a problem in the 24 VAC circuit of electronic ignition systems. If the fryer is equipped with a filtration system, first verify that the drain valve is fully closed. (The valve is equipped with a microswitch that must be closed for power to reach the gas valve. Often, although the valve handle appears to be in the closed position, the microswitch is still open.) If the valve is fully closed, or the fryer does not have a filtration system, refer to the troubleshooting guides in this chapter.

#### Problems Related to the Gas Valve

If the problem is not in the 24 VAC circuit, it is most likely in the gas valve itself, but before replacing the gas valve, refer to the troubleshooting guides in this chapter.

# YSCFC SERIES FLATBOTTOM GAS FRYERS

## CHAPTER 1: SERVICE PROCEDURES

---

### 1.7.2 Improper Burner Functioning

With problems in this category, the burner ignites but exhibits abnormal characteristics such as "popping", incomplete lighting of burner, fluctuating flame intensity, and flames "rolling" out of the fryer.

**"Popping"** indicates delayed ignition. In this condition, the main gas valve is opening but the burner is not immediately lighting. When ignition does take place, the excess gas "explodes" into flame, rather than smoothly igniting.

The primary causes of popping are:

- Incorrect or fluctuating gas pressure
- Clogged burner orifices
- Clogged burners
- Inadequate make-up air
- Heat damage to the controller or ignition module
- An out-of-adjustment ignitor or broken ignition wire
- A defective ignition module

If popping occurs only during peak operating hours, the problem may be incorrect or fluctuating gas pressure. Verify that the incoming gas pressure (pressure to the gas valve) is in accordance with the appropriate CE or Non-CE requirements listed in the Installation and Operation manual that came with the fryer, and that the pressure remains constant throughout all hours of usage. Refer to **Adjusting Burner Manifold Pressure** in Section 1.4 if burner manifold pressure is suspected of being incorrect.

On systems equipped with electronic ignition, verify that the ignitor is properly adjusted (electrode tip and ignitor positioned properly over middle burner).

Clogged burners and burner orifices are also likely causes of delayed ignition. Clogged burners are indicated by uneven flame or partial flame on the burner face. Clogged orifices are indicated by no flame.

Another cause of popping is an insufficient air supply or drafts. Check for "negative pressure" conditions in the kitchen area. If air is flowing into the kitchen area, more air is being exhausted than is being replenished and the burners may be starved for air.

If the fryer's gas and air supplies are okay, the problem most likely is with one of the electrical components. Examine the ignition module for signs of melting/distortion and/or discoloration due to excessive heat build-up in the fryer. (This condition usually indicates improper flue performance.).

## YSCFC SERIES FLATBOTTOM GAS FRYERS

### CHAPTER 1: SERVICE PROCEDURES

---

Also, examine the controller for the same conditions. A melted or distorted ignition module is automatically suspect and should be replaced, but unless the condition causing excessive heat in the fryer is corrected, the problem is likely to recur.

Next, ensure the ignition wire is connected properly at both ends and examine it for obvious signs of damage. Again, if damage is due to excessive heat in the fryer, that problem must also be corrected.

 **DANGER**

**MAKE SURE YOU ARE HOLDING THE INSULATED HANDLE OF THE SCREWDRIVER AND NOT THE BLADE. THE SPARKING CHARGE IS APPROXIMATELY 25,000 VOLTS.**

Check for proper operation by disconnecting the wire from the ignitor, inserting the tip of a screwdriver into the terminal, and holding it near the frame of the fryer as the power switch is placed in the "ON" position. A strong, blue spark should be generated for at least 11 seconds.

*Fluctuating flame intensity* is normally caused by either improper or fluctuating incoming gas pressure, but may also be the result of variations in the kitchen atmosphere. Verify incoming gas pressure in the same way as for "popping", discussed in the preceding paragraphs. Variations in the kitchen atmosphere are usually caused by air conditioning and/or ventilation systems starting and stopping during the day. As air conditioning/ventilation systems start and stop, the pressure in the kitchen may change from positive or neutral to negative, or vice versa. Changes in airflow patterns may affect flame intensity.

*Flames "rolling" out of the fryer* are usually an indication of negative pressure in the kitchen. Air is being sucked out of the fryer enclosure and the flames are literally following the air. If negative pressure is not the cause, check for high burner-manifold gas pressure in accordance with the procedures in Section 1.4. An obstructed flue or a faulty blower, which prevents the fryer from properly exhausting, may also be the cause.

*Excessively noisy burners*, especially with *flames visible above the flue opening*, may indicate that the burner gas pressure is too high or the gas valve vent-tube is blocked (if applicable). If the gas pressure is correct, and the vent-tube is unobstructed (if applicable), the gas valve regulator is probably defective.

# YSCFC SERIES FLATBOTTOM GAS FRYERS

## CHAPTER 1: SERVICE PROCEDURES

---

### 1.7.3 Improper Temperature Control

Temperature control, including the melt cycle, is a function of several interrelated components, each of which must operate correctly. The principal component is the temperature probe. Depending upon the specific configuration of the fryer, other components may include the Thermatron board, the controller itself, and the ignition module.

Improper temperature control problems can be categorized into melt cycle problems and failure to control at setpoint.

#### Failure to Control at Setpoint

In fryers equipped with a Thermatron temperature controller, the problem may be that the temperature probe is improperly positioned. Other causes may be the Thermatron board or the potentiometer. Possible causes are that the potentiometer is out of calibration, or the temperature probe or Thermatron board is defective. Refer to Section 1.5 for instructions on calibrating the Thermatron temperature controller.

### 1.7.4 Filtration Problems

Whenever the complaint is "the pump is running, but no oil is being filtered", check the filter paper or filter leaf (screen) connections and ensure they are properly connected. Ensure the filter paper or filter leaf is not clogged with food debris or sediment and is properly assembled.

If the pump motor overheats, a circuit breaker in the filter circuit will trip and the motor will not start until it is reset. If the pump motor does not start after pressing the circuit breaker, press the red reset switch located on the rear of the motor. If the pump then starts, something caused the motor to overheat. Maybe several frypots were filtered one after the other and the pump got hot. Letting the motor cool down for at least a half-hour is all that is required in this case. More often, the pump overheated for one of the following reasons:

- Shortening was solidified in the filter leaf or filter lines.
- The operator attempted to filter unheated oil or shortening. Cold oil and shortening are thicker and cause the pump motor to work harder and overheat.

If the motor runs but the pump does not, there is a blockage in the pump. An incorrectly assembled filter leaf allows food particles and sediment to pass through the filter pan and into the pump. When sediment enters the pump, the gears bind up causing the motor to overheat, tripping the thermal overload. Particles large enough to clog the pump may indicate that the crumb tray is not being used, and that the filter leaf is not properly assembled. Solidified shortening in the pump will produce the same result.



## YSCFC SERIES FLATBOTTOM GAS FRYERS

### CHAPTER 1: SERVICE PROCEDURES

A pump seized by debris or hard shortening must be disassembled, cleaned and reassembled as follows:

1. Disconnect power to the filter system.
2. Remove the front cover of the pump to access the gears inside, if the pump is accessible while still inside the cabinet. If the front cover is not accessible, the pump must be removed from the pump motor (remove input/output plumbing from the pump prior to removing pump). Remove setscrews to disengage the pump from the motor.

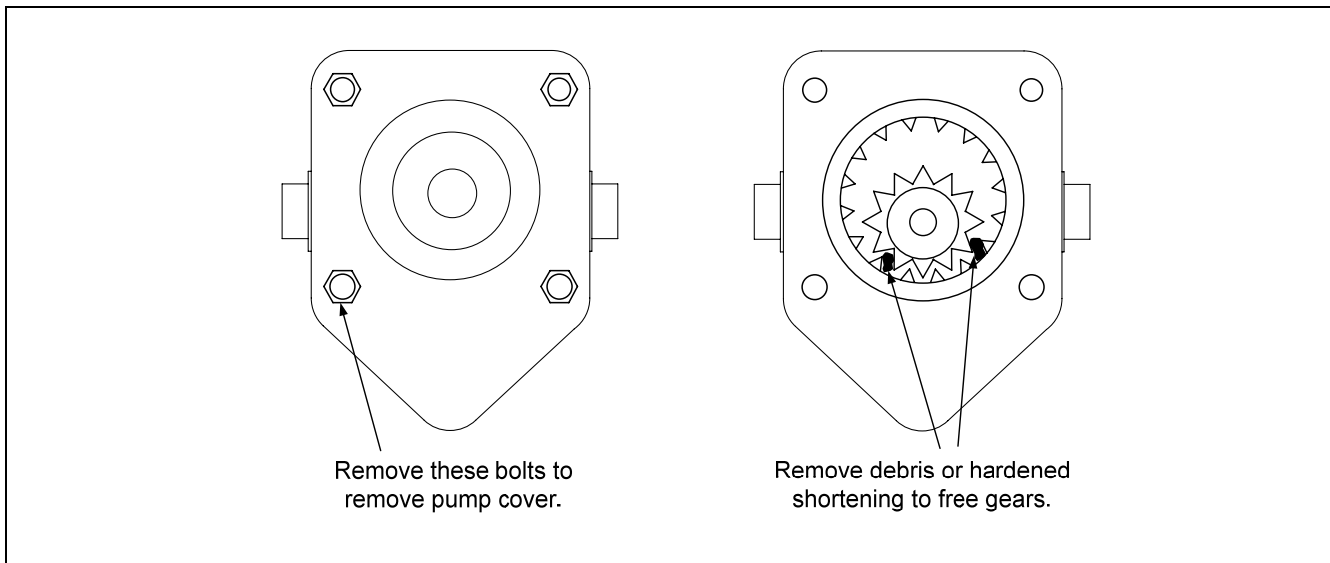

3. Prior to reassembly, the inside housing must be clean and free of any sediment or debris. Failure to completely clean the inside housing and ring gear will cause gear binding after reassembly.
4. During reassembly, partially install the housing bolts in a star pattern, leaving a 1/8-inch (3 mm) gap between the cover and housing flanges. Ensure there is no shortening or oil in the filter pan, and that the filter pan is disconnected. With the motor running slowly draw the cover in, evenly tightening the housing bolts. When the cover is snug on the housing tighten all bolts to 15 inch-lbs (1.7 Nm) ensuring that the pump is working correctly. Turn the motor off.

The electronics of the SUFF/UFF filtration system are simple and straightforward. Microswitches attached to handles for each vat and wired in parallel provide the 24 VAC required to activate the pump relay coil. When the handles are moved to the ON position, the activated pump relay coil pulls the pump motor switch in, supplying power to the pump motor.

Filter systems equipped with oil-return heaters are wired into the 120 VAC source, which remains energized as long as the unit is plugged in.

# YSCFC SERIES FLATBOTTOM GAS FRYERS

## CHAPTER 1: SERVICE PROCEDURES

---

### 1.7.5 Leakage

Frypot leaks are usually due to improperly sealed high-limit, temperature probe or oil-return and drain fittings. When installed or replaced, each of these components must be sealed with Loctite PST567 sealant or equivalent to prevent leakage. In very rare cases, a leak may develop along one of the welded corners of the frypot. When this occurs, the frypot must be repaired or replaced.

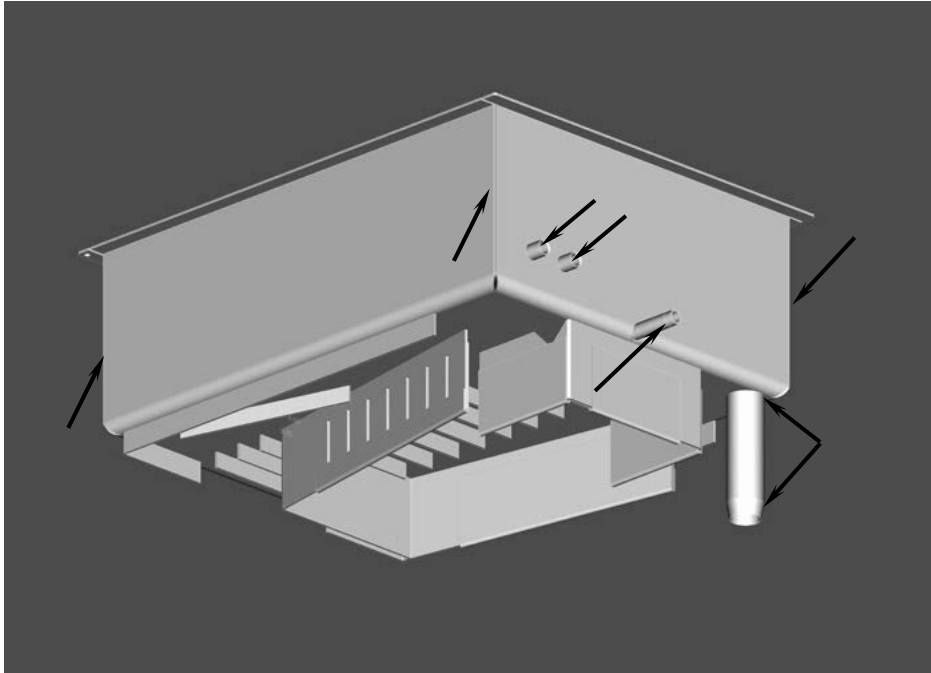

Frypot locations (indicated by arrows) where potential leaks could occur.

**YSCFC SERIES FLATBOTTOM GAS FRYERS  
CHAPTER 1: SERVICE PROCEDURES**

## 1.8 Troubleshooting Guides

The following procedures **must be performed** by an ASA. They are provided as an aid to expedite troubleshooting and repair of YSCFC Series frying systems.

### 1.8.1 Main Burner Malfunctions

PROBLEM	CORRECTIVE ACTION
<b>Main burner will not come on even though air blower is in operation; no gas pressure at main burner.</b>	<ol style="list-style-type: none"> <li>1. Check that the combination gas valve is ON.</li> <li>2. Check high temperature safety switch. Replace if defective.</li> <li>3. Check air prover switch. Ensure green prover light is on. If not, check for 24 VAC going into and coming out of the air prover switch.</li> </ol>
<b>Air blower is not operating, although power is present at the fryer.</b>	<ol style="list-style-type: none"> <li>1. Cooked product or other material may have fallen into the flue and lodged in the blower wheel, preventing it from turning. Clean out flue and blower wheel.</li> <li>2. Blower motor may have overheated and shut off. This condition will correct itself when motor cools (20 minutes). If problems with blower overheating persist, call for service.</li> <li>3. If fryer is equipped with a Thermatron controller, the temperature probe or the controller board may be defective.</li> </ol>
<b>Main burner flames are small and appear lazy; Oil does not come up to temperature quickly.</b>	<ol style="list-style-type: none"> <li>1. Check gas pressure at the pressure tap of the burner manifold. Use a standard water-type U-gauge manometer. With the burner in operation, the pressure should be about 4" W.C. on natural and 11" W.C. on propane (LP) gases. If not, unscrew the cover of the pressure regulator adjustment and turn the adjusting screw clockwise to increase gas pressure (or counterclockwise to decrease the pressure). Replace cover and plug.</li> </ol>
<b>There are signs of excessive frypot temperature; oil becomes discolored quickly.</b>	<ol style="list-style-type: none"> <li>1. Check the frypot for excessive build up of debris.</li> <li>2. Thermatron controller may be out of calibration. Re-calibrate in accordance with instructions in Section 1.5.</li> <li>3. Check gas pressure.</li> <li>4. Oil of inferior quality or used too long. Replace with quality oil.</li> </ol>

**YSCFC SERIES FLATBOTTOM GAS FRYERS  
CHAPTER 1: SERVICE PROCEDURES**

---

**1.8.2 Indicator Lights**

The fryer's indicator lights serve a diagnostic purpose. All lights are lit when the fryer is working properly. The green light on the control panel will cycle on and off as the fryer calls for heat. Use the following procedures to isolate problems indicated by light combinations.

Turn the temperature dial to 400°F (204°C) to ensure the sensor will demand heat. Check all indicator lights in the fryer cabinet and on the control panel. [**Older units** may have power and reset switches with different colored lights (orange, amber, red, green, white.). **Common Cabinet units** have a white power light and a green air prover light. Substitute the light color of the correct color switch with the respective "green light" switch in the following troubleshooting procedures. The control panel light colors haven't changed.]

When turning the power switch "ON" and resetting the safety (reset) switch, check for the following:

LIGHT INDICATION	PROBABLE CAUSE	CORRECTIVE ACTION
<b>GREEN LIGHT/POWER SWITCH IS "ON"</b> <b>GREEN LIGHT/SAFETY (RESET) SWITCH IS "OFF"</b> <b>GREEN LIGHT/CONTROL PANEL IS "OFF"</b> <b>RED LIGHT/CONTROL PANEL IS "OFF"</b>	1. The drain valve is open.  2. The drain switch is defective.	1. Ensure the drain valve is completely closed, and then turn the reset switch to "ON".
<b>GREEN LIGHT/POWER SWITCH IS "OFF"</b> <b>GREEN LIGHT/SAFETY (RESET) SWITCH IS "OFF"</b> <b>GREEN LIGHT/ CONTROL PANEL IS "OFF"</b> <b>RED LIGHT/CONTROL PANEL IS "OFF"</b>	1. No power to fryer.  2. Fuse is blown.  3. Reset switch circuit defective.	1. Check power source, power cords and breaker. Ensure that electricity is available to the fryer.  2. Replace fuse.  3. If fryer does not function after resetting the reset switch, contact an ASA for assistance.

# YSCFC SERIES FLATBOTTOM GAS FRYERS

## CHAPTER 1: SERVICE PROCEDURES

### 1.9 WIRING DIAGRAMS

**NOTE:** The diagrams in this section depict wiring as of the date of manual publication. It may not reflect design changes made to the equipment after publication. Always refer to the wiring diagram affixed to the unit when actually troubleshooting this equipment.

#### 1.9.1 Wiring for Common Cabinet Flatbottom without Boil Out

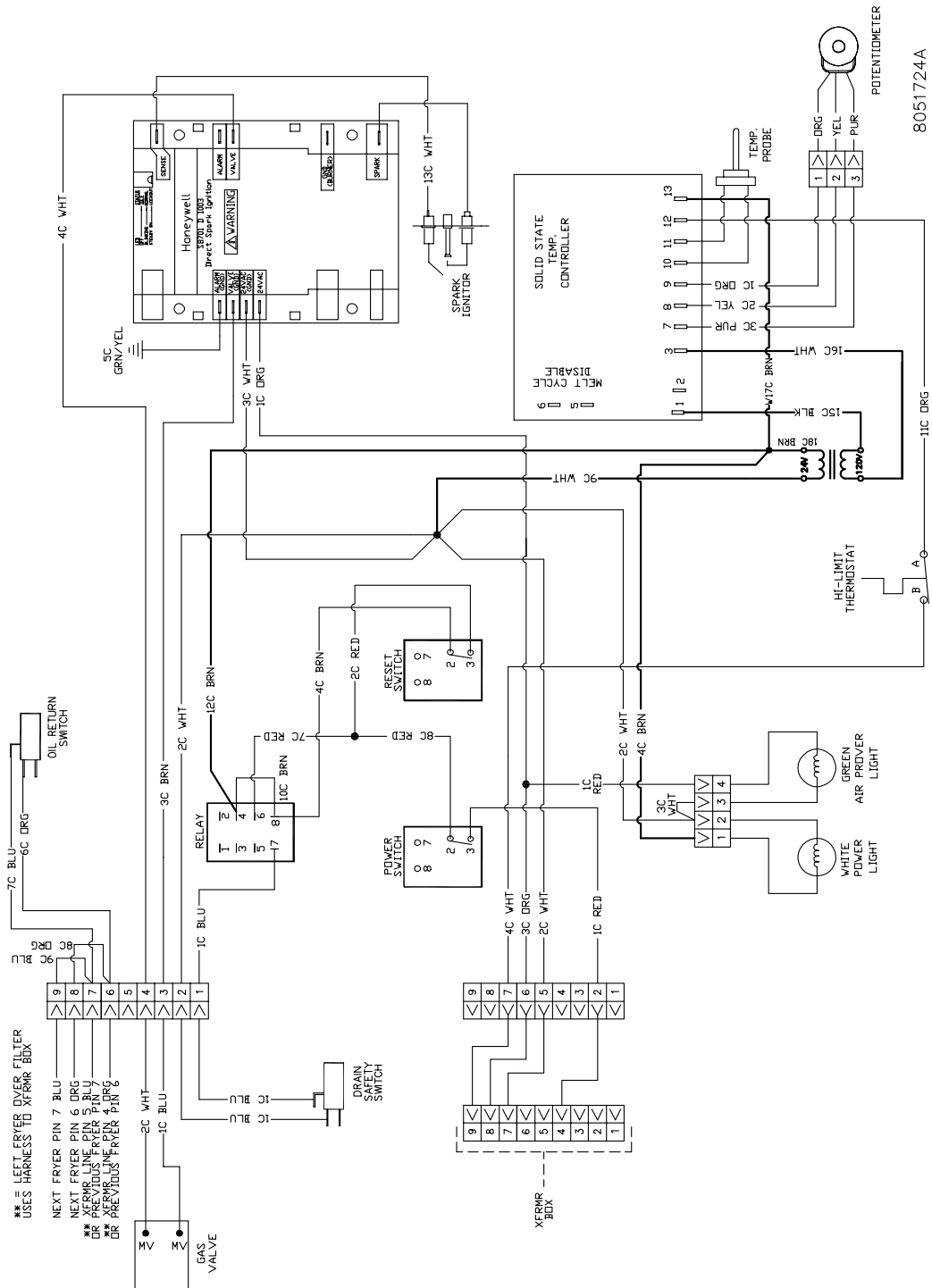

# YSCFC SERIES FLATBOTTOM GAS FRYERS

## CHAPTER 1: SERVICE PROCEDURES

### 1.9.2 24/24 Filter Wiring

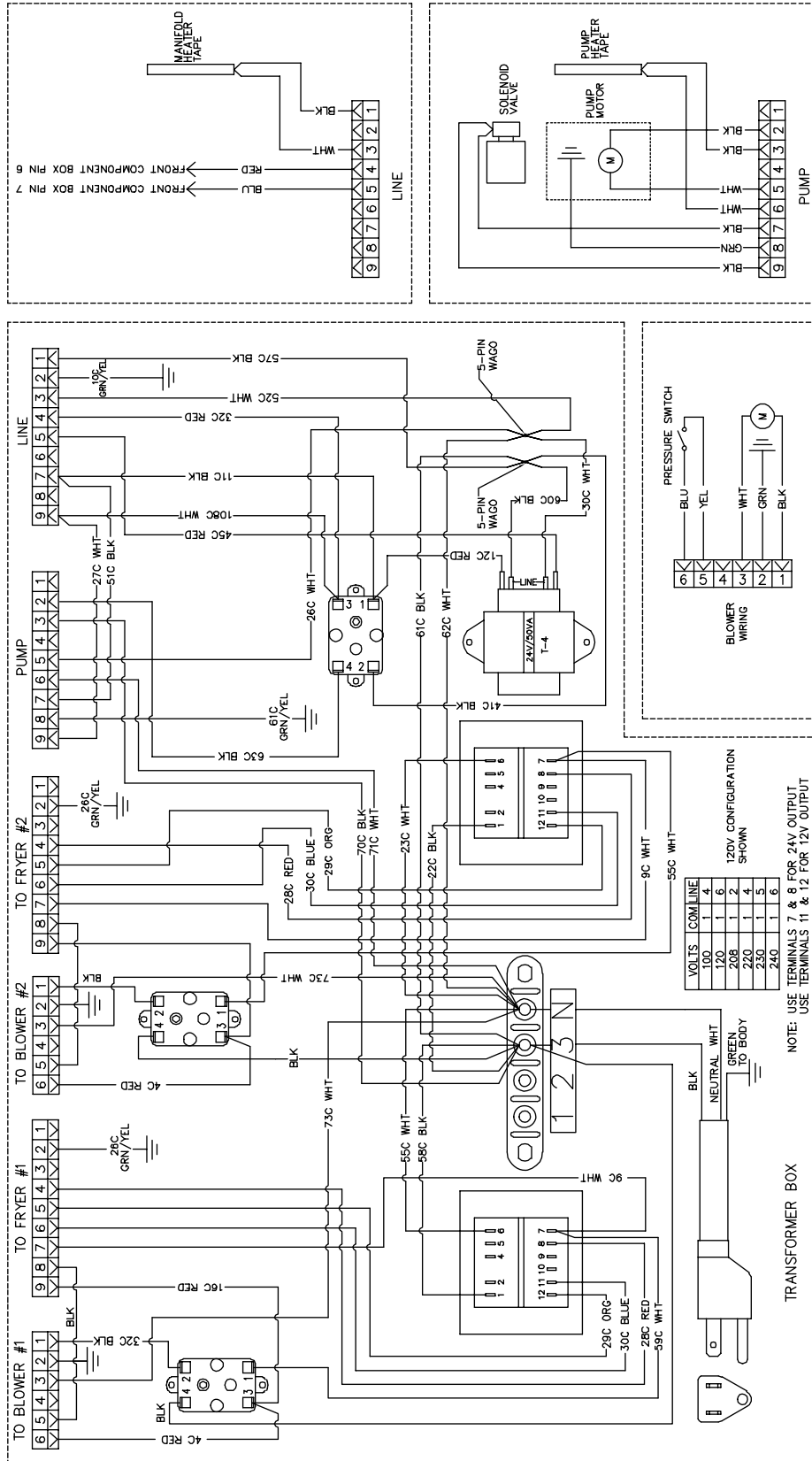

8051610D

# YSCFC SERIES FLATBOTTOM GAS FRYERS

## CHAPTER 1: SERVICE PROCEDURES

### 1.9.3 18/24 Common Cabinet Transformer Box

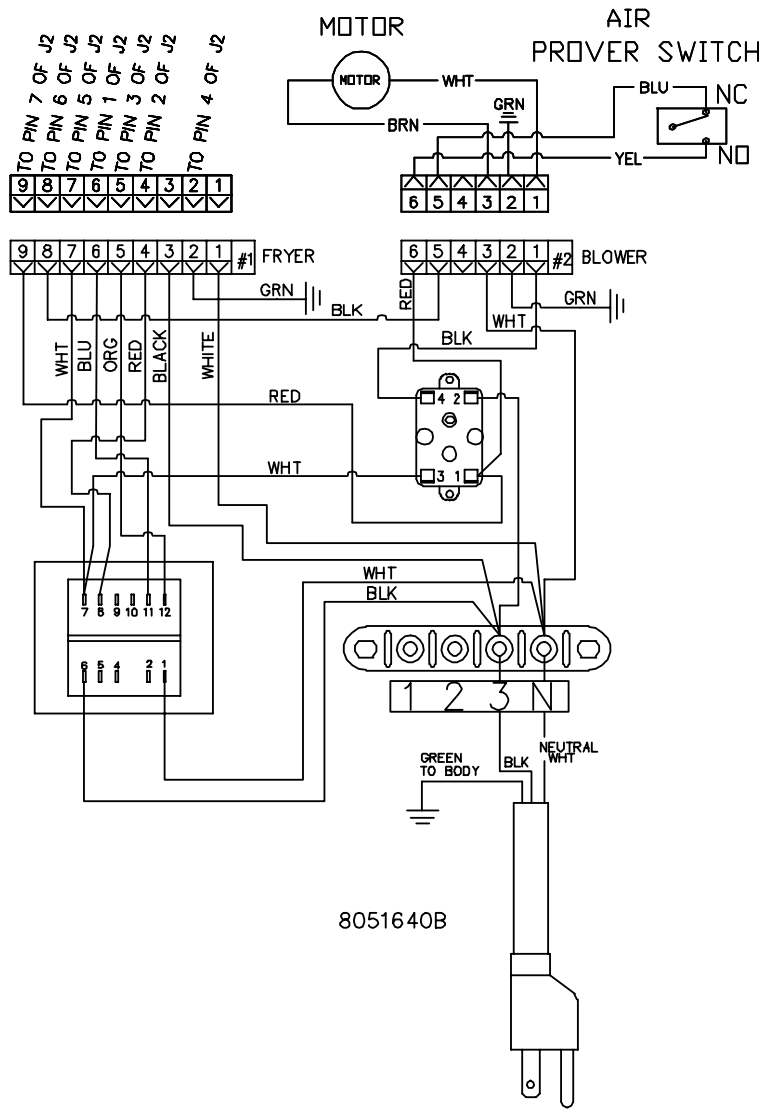

# YSCFC SERIES FLATBOTTOM GAS FRYERS

## CHAPTER 2: PARTS LIST

### 2.1 Blower Assembly and Combustion Air

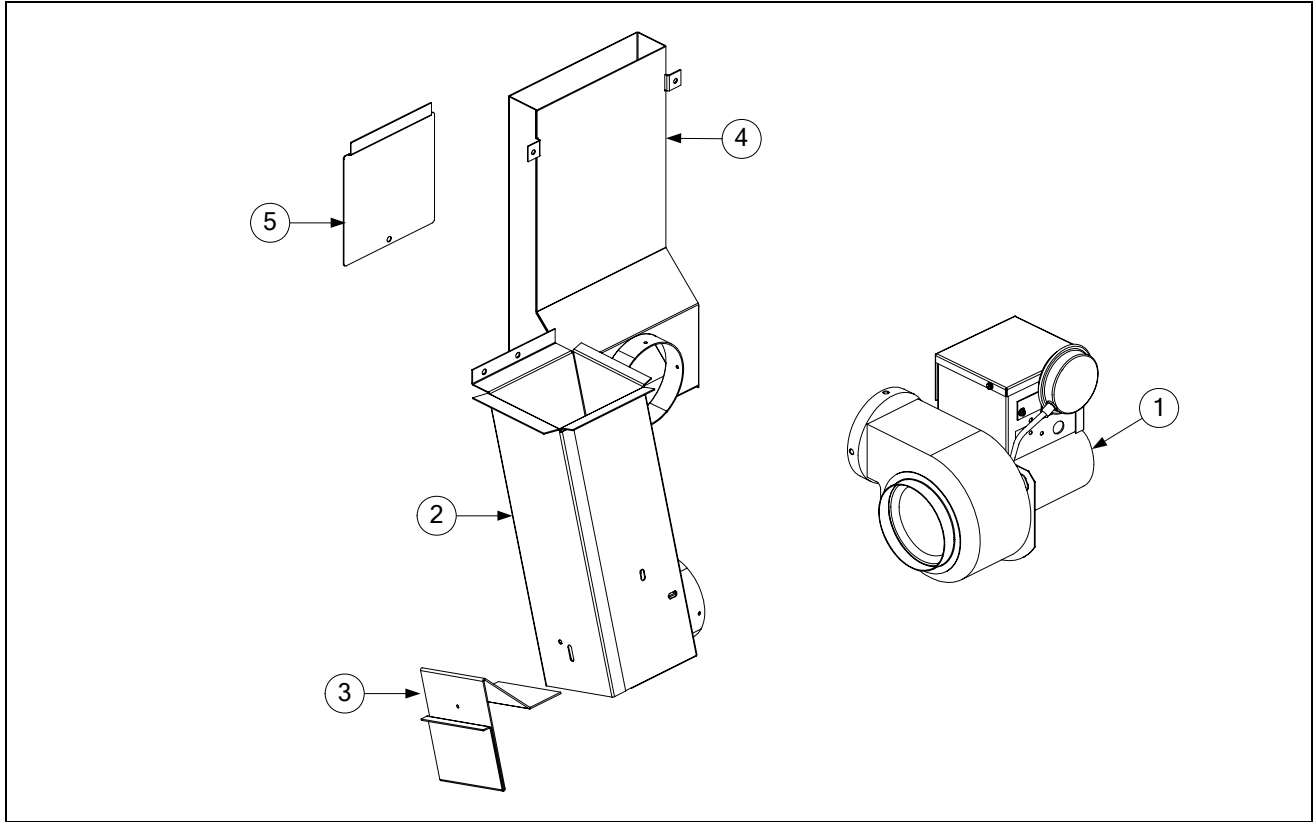

ITEM	PART #	COMPONENT
1	108-0471SP	Motor, Blower Assembly, 120V
2	823-3162	Duct Assembly, Inlet
3	200-1428	Gate, Air Flow
4	823-3166	Duct Assembly, Outlet
5	200-1471	Door, Outlet Duct Access

\* Not illustrated.



**YSCFC SERIES FLATBOTTOM GAS FRYERS**  
**CHAPTER 2: PARTS LIST**

**2.2 Burner Manifold and Related Components**

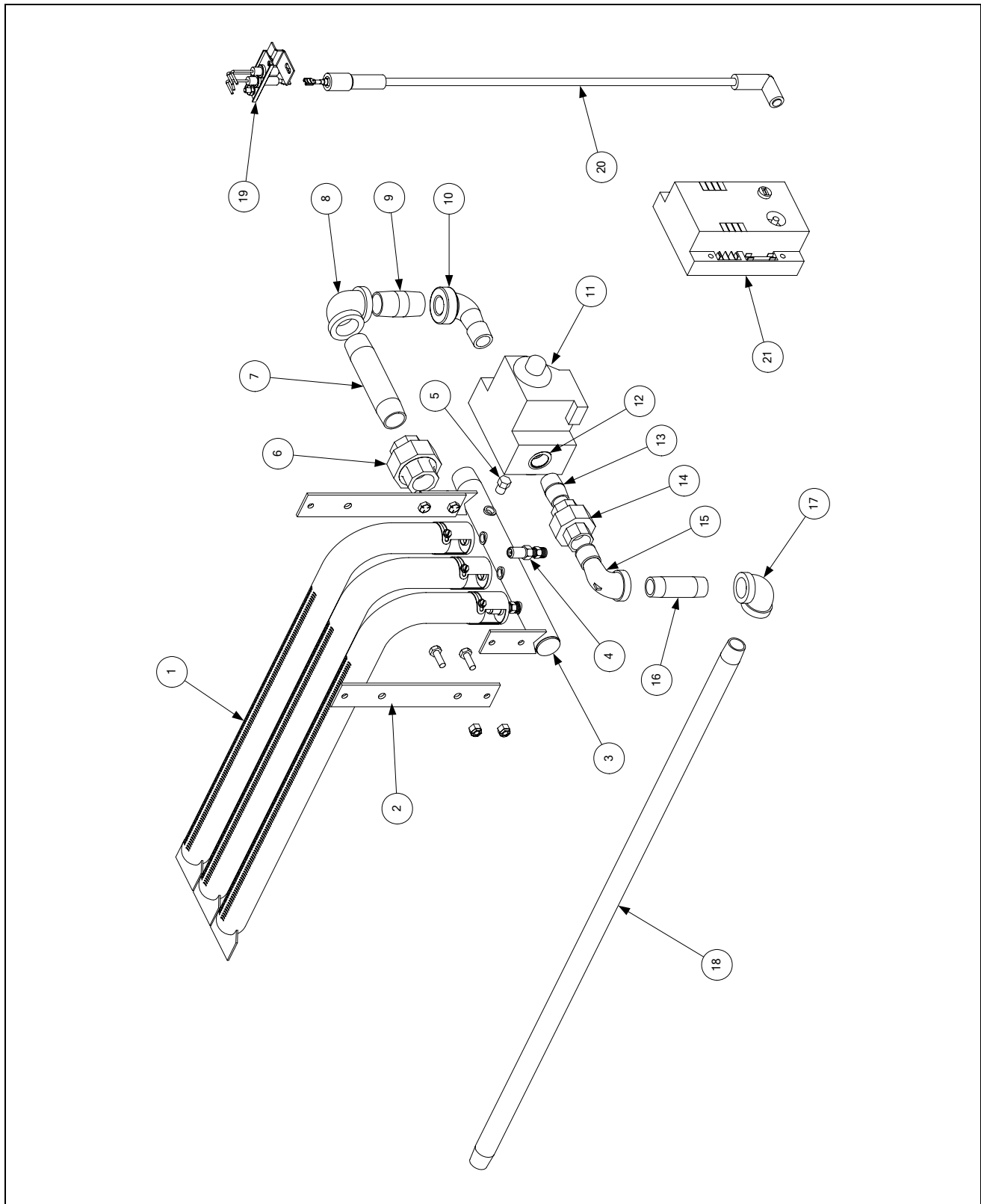

**YSCFC SERIES FLATBOTTOM GAS FRYERS  
CHAPTER 2: PARTS LIST**

**2.2 Burner Manifold and Related Components (cont.)**

ITEM	PART #	COMPONENT
1	810-2129	Tube, Burner
2	200-1670	Support, Left or Right Manifold
3	810-2168	Burner Manifold Assembly
4		<b>Orifice</b>
	810-2827	2.82mm (#34) Natural Gas
	810-2830	1.78mm (#50) Propane (LP) Gas
5	813-0154	Plug, 1/8" NPT (Manifold Pressure Tap Plug)
6	813-0174	Union, 3/4" NPT Pipe
7	813-0300	Nipple, 3/4" NPT x 4 1/2"
8	813-0066	Elbow, 90° x 3/4" NPT
9	813-0112	Nipple, 3/4" NPT x 2"
10	813-0168	Elbow, 90° x 3/4" NPT Street
11		<b>Valve, Gas</b>
	807-3555	24V Natural (G20/G25) Honeywell
	807-3690	24V Propane (LP) (G31) Honeywell
*	106-6553	Vent Tube
12	813-0763	Bushing, 3/4" NPT to 1/2" NPT
13	813-0022	Nipple, 1/2" NPT x Close
14	813-0173	Union, 1/2" NPT Pipe
15	813-0165	Elbow, 90° x 1/2" NPT Street ( <i>for single fryers, use 45° 813-0342</i> )
16	813-0265	Nipple, 1/2" NPT x 2 1/2"
17	813-0062	Elbow, 90° x 1/2" NPT
18	813-0845	Nipple, 1/2" NPT x 29 3/4" ( <i>single fryers, use 24 1/2" 813-0788, 813-0729 23"</i> )
*	813-0608	Coupling, 1/2" NPT
*	813-0475	Tee, 1" x 1/2" x 3/4"
*	813-0460	Nipple, 1/2" x 3" NPT
*	813-0421	Nipple, 1" x 18" NPT
*	813-0418	Nipple, 1/2" x 17" NPT
*	813-0275	Nipple, 1/2" x 9" NPT
*	813-0266	Elbow, Street, 1" NPT
*	813-0247	Nipple, 1/2" x 3.5" NPT
*	813-0087	Nipple, 1/2" x 1.5" NPT
*	813-0031	Bushing, Hex, 3/4" NPT x 1/2"
*	810-2898	Clamp, Pipe, 1"
		<b>Electronic Ignition Components</b>
19	807-3556	Ignitor and Flame Sensor Assembly ( <i>does not include flame sensor wire or cable</i> )
*	106-4580	Ignitor Bracket, Flat Style
20	106-3338	Ignition Cable ( <i>includes 807-3742 cable and 807-3484 Rajah connector</i> )
21	807-3365	Module, Ignition Spark, Honeywell
*	W106C6SP	Sensor Cable

\*Not illustrated.

YSCFC SERIES FLATBOTTOM GAS FRYERS  
CHAPTER 2: PARTS LIST

2.3 Flue Caps, Top Caps, and Related Components

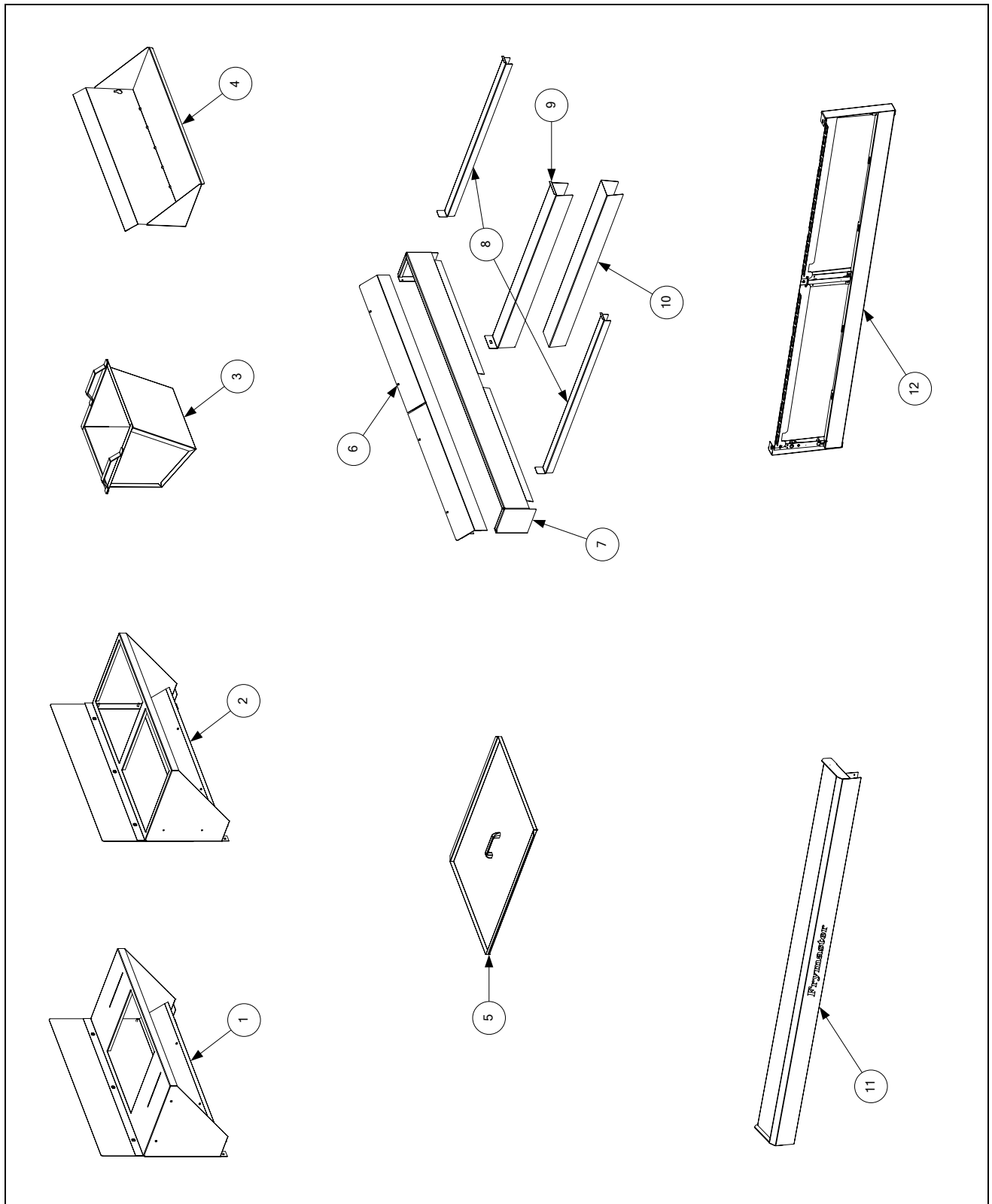

**YSCFC SERIES FLATBOTTOM GAS FRYERS  
CHAPTER 2: PARTS LIST**

**2.3 Flue Caps, Top Caps, and Related Components (cont.)**

ITEM	PART #	COMPONENT
1	106-3253SP	Frame, Single Crumb Dump
2	106-1638SP	Frame, Double Crumb Dump
3	823-4125	Insert, Pan Crumb Dump, ½ Size
4	823-4127	Tray, 12424 Single
5	106-2840SP	Cover, 1824G Frypot ( <i>use 106-2839SP for 2424G Frypot</i> )
6		<b>Deflector, Flue Cap Oil</b>
	230-1387	For use on 2-2424G (2-vat 2424 System)
	230-1390	For use on 3-2424G (3-vat 2424 System)
	230-1385	For use on 2-1824G (2-vat 1824 System)
	230-2996	For use on 2-2424/15R (3-vat 24/15 System)
7		<b>Flue Cap</b>
	230-0778	For use on 2-2424G (2-vat 2424 System)
	230-1589	For use on 2-1824G (2-vat 1824 System)
	230-2966	For use on 2-2424/15R (3-vat 24/15 System)
	230-0396	For use on 3-2424G (3-vat 2424 System)
8	210-4317	Edge Strip, Frypot
9	210-4313	Joiner Strip (joins frypots within a system)
10	210-4598	Joiner Strip (joins one fryer system to another)
*	230-3089	Joiner Strip (joins matching cabinet to fryer)
11		<b>Marine Edge</b>
	823-5640	2-vat 2424, Without Notches
	823-5816	2-vat 2424, Notched Right End
	823-5817	2-vat 2424, Notched Left End
	823-5829	2-vat 1824, Notched Left End
	823-5514	3-vat 2424, Without Notches
	823-5872	3-vat 2424, Notched Right End
12		<b>Frame, Control Panel</b>
	106-5875	224
	106-8395	324
	106-6504	1824
	106-7947	24/24/MC15
*	803-0293	Gloves, Neoprene Hot Oil

\* Not illustrated.



**YSCFC SERIES FLATBOTTOM GAS FRYERS  
CHAPTER 2: PARTS LIST**

**2.4 Cabinetry (cont.)**

ITEM	PART #	COMPONENT
1	220-0366	Back, Upper Cabinet, 2424
	220-0862	Back, Upper Cabinet, 1824
	220-2938	Back, Upper Cabinet, MC15
2	220-0365	Back, Lower Cabinet, 2424
	220-0863	Back, Lower Cabinet, 1824
	220-2939	Back, Lower Cabinet, MC15
3	231-0395	Panel, Left Side, Stainless Steel Cabinet
*	232-0395	Panel, Right Side, Stainless Steel Cabinet
*	221-0853	Panel, Left Side, Stainless Steel Cabinet with Cut-out
4	222-0853	Panel, Right Side, Stainless Steel Cabinet with Cut-out
5	200-1471	Door, Access Duct
6	220-0762	Brace, Firebox
7	220-0761	Brace, Frypot
8	220-0369	Post, Front Cabinet
9	220-0404	Post, Rear Cabinet
10	810-0357	Caster, 5" with Brake Swivel (4-hole pattern)
*	810-0356	Caster, 5" without Brake Swivel (4-hole patter)
11	220-3537	Bridge, Filter Pump
12	220-3790	Support, Filter Pump Motor
13	221-0980	Guide, Filter Pan, Left
14	222-0980	Guide, Filter Pan, Right
15	221-4734	Rail, Filter Pan, Left
16	222-4734	Rail, Filter Pan, Right
17	220-4149	Stop, Drain Pan, 2424
*	220-4891	Stop, Drain Pan, MC15
18	220-0760	Divider, Frypot
19	200-9231	Brace, Cabinet Front, 224
	220-3793	Brace, Cabinet Front, 324
	220-3501	Brace, Cabinet Front, 324, Filter on Right (facing the fryer)
	200-9240	Brace, Cabinet Front, 1824
	220-2970	Brace, Cabinet Front, 24/24/15
20	200-9229	Brace, Cabinet Top, 224
	200-3793	Brace, Cabinet Top, 324
	200-9239	Brace, Cabinet Top, 1824
	220-2943	Brace, Cabinet Top, 24/24/15
21		<b>Oil Return Manifold</b>
	810-3088	224
	810-3313	324, Filter on Left (facing the fryer)
	810-3314	324, Filter on Right (facing the fryer)
	810-3093	18/24
	810-3239	24/24/15
*		<b>Cabinet Base</b>
	106-5788	224
	106-8393	324, Filter on Left (facing the fryer)
	106-8394	324, Filter on Right (facing the fryer)
	106-6502	18/24
	106-7948	24/24/15

\* Not illustrated.

**YSCFC SERIES FLATBOTTOM GAS FRYERS  
CHAPTER 2: PARTS LIST**

**2.5 Door Assemblies and Component Parts**

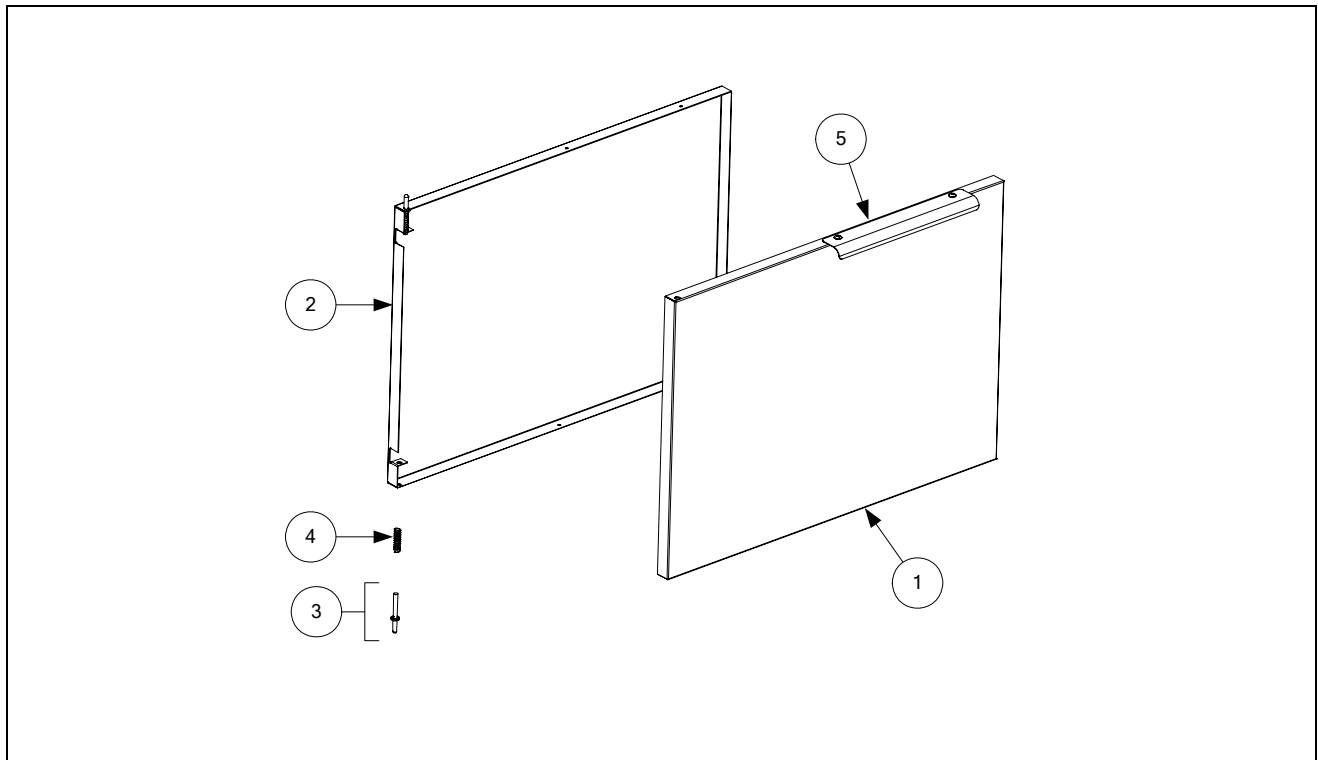

ITEM	PART #	COMPONENT
1	824-1912	Panel, Door, 2424
	824-1958	Panel, Door, 1824
	824-1954	Panel, Door, MC15
2	220-4128	Liner, Door, 2424
	220-4742	Liner, Door, 1824
	220-4666	Liner, Door, MC15
3	106-4067	Pin Assembly
4	810-0275	Spring
5	210-8077	Handle

YSCFC SERIES FLATBOTTOM GAS FRYERS  
CHAPTER 2: PARTS LIST

2.6 Control Panels, Wireways, and Related Components

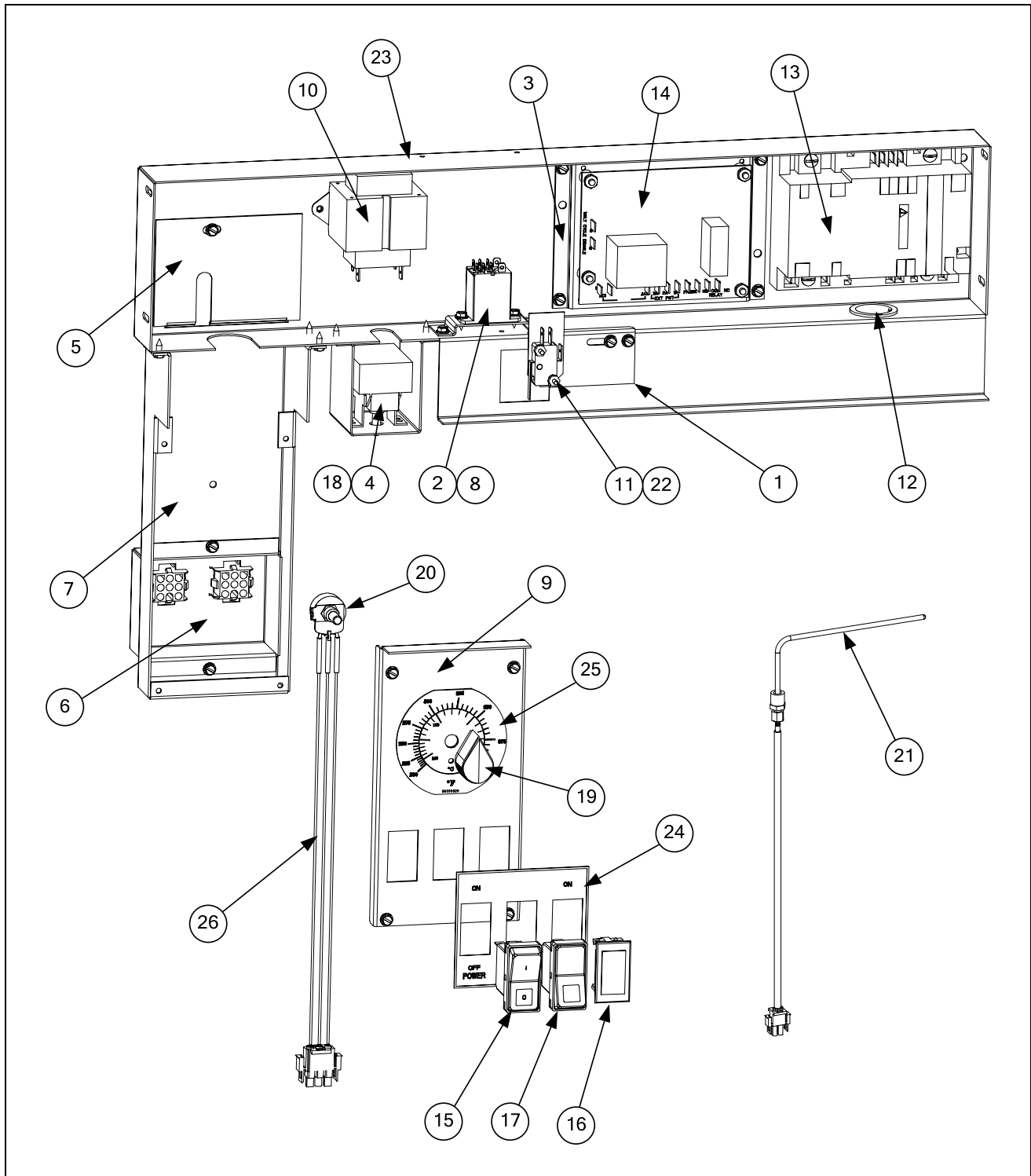



**YSCFC SERIES FLATBOTTOM GAS FRYERS  
CHAPTER 2: PARTS LIST**

---

**2.6 Control Panels, Wireways, and Related Components (cont.)**

<b>ITEM</b>	<b>PART #</b>	<b>COMPONENT</b>
1	106-6060	Plate, Microswitch Adjustment
2	807-4114	Relay, Latch/Filter 24VAC Coil
3	200-4719	Plate, Interface Board Mounting
4	200-9681	Support, High Limit Thermostat
5	200-9812	Plate, Component Box Cover
6	220-1283	Box, Component Harness
7	220-1284	Housing, Thermostat
8	220-3769	Bracket, Relay
9	230-1282	Plate, Thermatron Face
10	807-0800	Transformer, 120V 50/60 Hz – 24V, 50 VA
11	807-2103	Microswitch, Straight Lever
12	807-2469	Bushing, Heyco, 1" ID
13	807-3365	Ignition Module, Honeywell
14	826-2086	Thermatron Board, 115/230V, Extended Melt Cycle
15	807-3574	Switch, Dean Power
16	807-3575	Switch, Hole Plug
17	807-3576	Switch, Reset-Rocker
18	807-3680	Thermostat, 450°F High-Limit w/Manual Reset
19	810-0110	Knob, Thermatron Control
20	826-2269	Potentiometer, Thermatron
21	106-2607	Probe, Thermatron (20" leads)
22	816-0220	Insulation, Switch
23	823-5765	Component Box
24	802-2050	Label, Three-Switch
25	802-2052	Label, Thermatron Dial
26	200-4719	Harness, Thermostat

# YSCFC SERIES FLATBOTTOM GAS FRYERS

## CHAPTER 2: PARTS LIST

### 2.7 Oil Return and Suction Manifolds

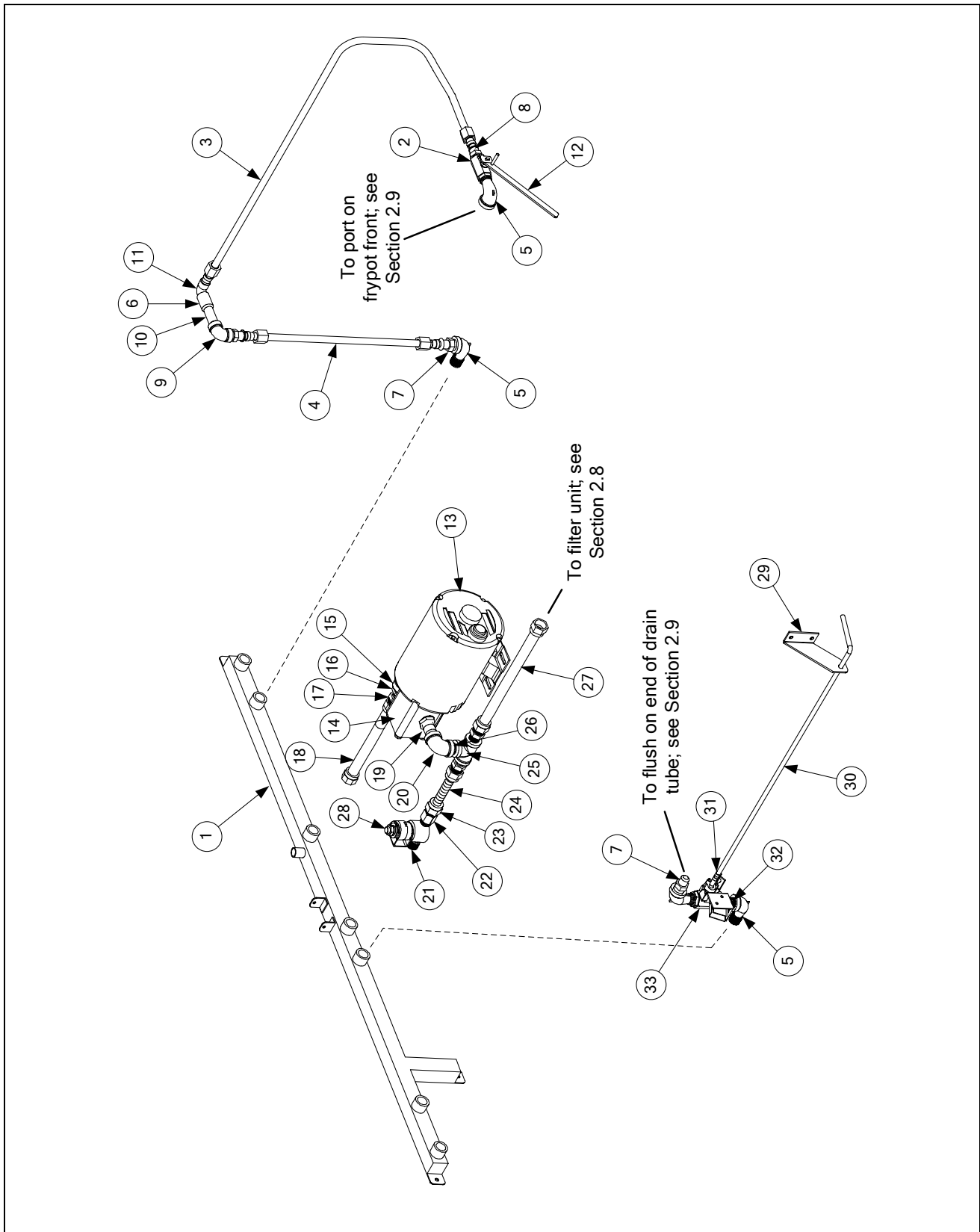

**YSCFC SERIES FLATBOTTOM GAS FRYERS  
CHAPTER 2: PARTS LIST**

**2.7 Oil Return and Suction Manifolds (cont.)**

<b>ITEM</b>	<b>PART #</b>	<b>COMPONENT</b>
1	810-3088	<b>Oil Return Manifold</b>
	106-5461	<b>Oil Return Plumbing</b>
2	810-2125	Drain Valve, 3/8" Ball Valve
3	810-3011	Tubing, Drain Valve, Front
4	810-3014	Tubing, Oil Return, Rear
5	813-0165	Elbow, Street, 1/2" x 1/2" NPT, 90°
6	813-0462	Coupling, 3/8"
7	813-0613	Flare Fitting, 1/2-37° x 1/2"
8	813-0614	Flare Fitting, 1/2-37° x 3/8"
9	813-0631	Elbow, 3/8" x 90°
10	813-0649	Nipple, Black Tube, 3/8" NPT x 2.5"
11	813-0894	Elbow, 3/8" NPT x 1/2-37° Flare
12	823-5815	Oil Return Handle
		<b>Pump and Motor</b>
13	810-3347	Pump, Viking 8 GPM
14	826-1712	Motor, 115V 60Hz ( <i>gasket included</i> )
*	826-1270	Motor, 230V 50/60Hz ( <i>gasket included</i> )
*	816-0093	Gasket, Pump/Motor ( <i>included with motor</i> )
15	813-0168	Elbow, 3/4" x 3/4" NPT, Street, 90°
16	813-0031	Bushing, Hex, 3/4" NPT x 1/2"
17	810-1668	Adapter, Male, 5/8" OD x 1/2"
18	810-1067	Flexline, 5/8" OD x 8.5" long
19	813-0298	Nipple, 1/2" x 2.0" NPT
20	813-0062	Elbow, 1/2", 90°
21	813-0304	Bushing, 1/2" x 1/4", Flush
22	813-0838	Nipple, 1/4" NPT, Close
23	810-1669	Adapter, Female, 7/8" OD x 1/2"
24	810-1339	Flexline, 5/8" OD x 4.5" long
25	813-0003	Tee, 1/2" x 1/2" x 1/2"
26	813-0022	Nipple, 1/2" x Close NPT
27	810-1055	Flexline, 5/8" OD x 11.5" long
28	106-3470SP	Valve, Solenoid, Female Pins
*	813-0265	Nipple, 1/2" x 2.5" NPT
*	807-2304	Heater Strip, 72", 120V/100W, Silicone
*	806-8004SP	Heater Strip, 56", 120V/40W, Silicone
*	807-1105	Heater Strip, 18", 120V/25W, Silicone
*	807-1420	Heater Strip, 36", 120V/25W, Silicone
29	220-0965	Mount, Handle, Drain Flush
30	220-0973	Handle, Drain Flush
31	809-0601	Clevis Clip
32	813-0087	Nipple, 1/2" x 1.50" NPT
33	106-4006	Valve, Flush

\* Not illustrated.

**YSCFC SERIES FLATBOTTOM GAS FRYERS  
CHAPTER 2: PARTS LIST**

**2.8 Filter Unit**

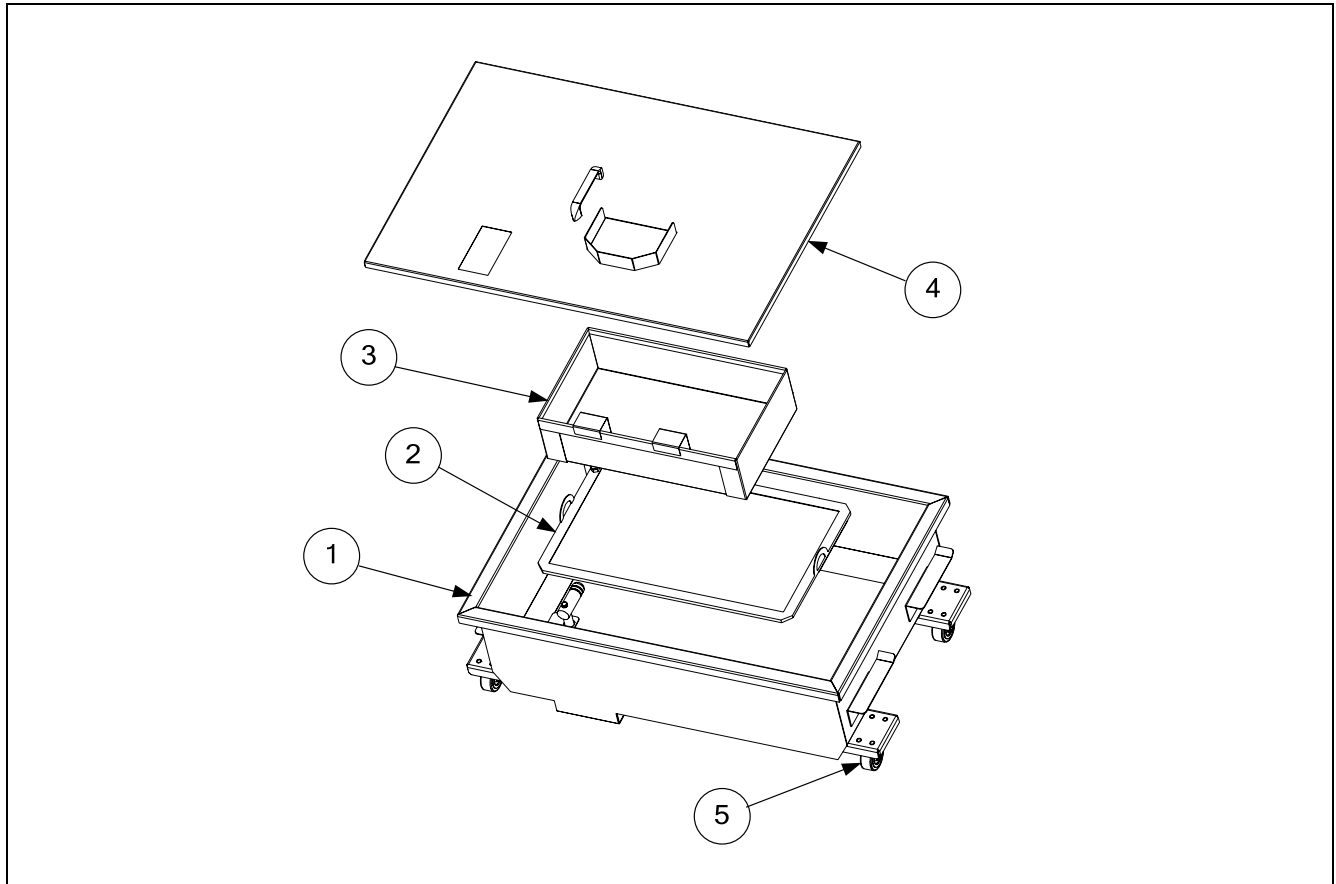

ITEM	PART #	COMPONENT
1	106-8465SP	Filter Pan (with 2" casters)
2	810-2800	Filter Leaf
3	823-5833	Crumb Basket
4	106-6131	Lid, Filter Pan
5	810-2805	Caster, 2"
*	826-1392	O-rings (for filter pan pick up tube; qty. 5)
*	816-0757	O-rings (for filter leaf)
*	803-0342	Filter Powder (pack of 25)
*	803-0289	Filter Paper, 22" x 34" (if using paper option)
*	220-1145	Sana Grid Screen (if using paper option)
*	810-3082	Hold Down Ring (if using paper option)

\* Not illustrated.

# YSCFC SERIES FLATBOTTOM GAS FRYERS

## CHAPTER 2: PARTS LIST

### 2.9 Frypot, Drain, and Oil Return Components

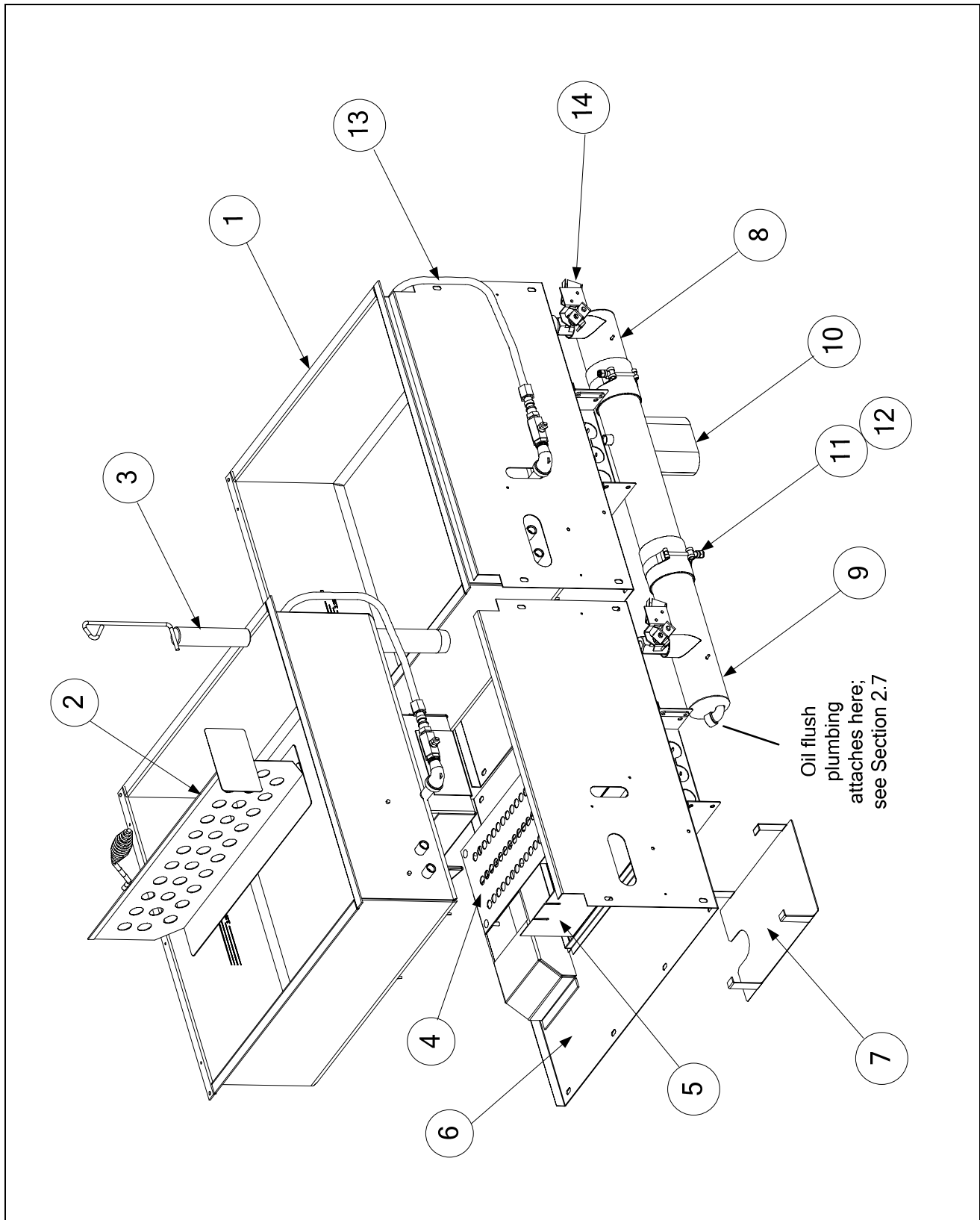

**YSCFC SERIES FLATBOTTOM GAS FRYERS  
CHAPTER 2: PARTS LIST**

**2.9 Frypot, Drain, and Oil Return Components (cont.)**

ITEM	PART #	COMPONENT
1	826-1823	Frypot Kit, 1824G ( <i>insulation included</i> )
	826-1821	Frypot Kit, 2424G ( <i>insulation included</i> )
2	823-3934	Divider, Frypot
3	823-3174	Plug, Frypot Drain
4	823-3190	Baffle, Secondary Air
5	210-1409	Spreader, Side Flame
6		<b>Firebox Assembly</b>
	823-5854	1824 ( <i>use with 823-5195 on 1824 units</i> )
	823-5195	2424 ( <i>use with 823-5854 on 1824 units</i> )
*	826-2036	Insulation, Pot FB
7	220-3512	Guard, Firebox, Bottom
8	812-1822	Tube, Drain, RH
9	812-1823	Tube, Drain, LH
10	812-2017	Tube, Drain, Center Dump
11	816-0772	Sleeve, Drain Tube Connector
12	809-0969	Clamp, 3" T-bolt
13	106-5461	<b>Oil Return Plumbing (<i>attaches to Item 21, Section 2.4, at the back of the unit</i>)</b>
	810-2125	Drain Valve, 3/8" Ball Valve
	810-3011	Tubing, Front
	810-3014	Tubing, Rear
	813-0165	Elbow, 1/2" x 1/2" Street, 90°
	813-0462	Coupling, 3/8"
	813-0613	Fitting, 1/2" x 1/2" 37° Flare
	813-0614	Fitting, 1/2" x 3/8" 37° Flare
	813-0631	Elbow, 3/8" x 90°
	813-0649	Nipple, 3/8" NPT x 2.50 inch
	813-0894	Elbow, 1/2" x 3/8" 37° Flare
14	106-4006	Drain Valve with Microswitch, 1/2"
*	816-0547	Sleeve, Red Valve Handle
*	807-2104	Microswitch, Drain Valve Roller Lever ( <i>use 902-2348 for M/S Guard</i> )
*	813-1790	Nipple, 1 1/4" x 5.85 inch NPT Toe
*	813-0165	Elbow, 1/2" x 90° NPT Street
*	813-0632	Elbow, 3/8" x 90° NPT Street
*	810-2125	Valve, 3/8", Oil Return, Ball ( <i>use 200-1143 for Nut Retainer</i> )
*	823-5815	Handle, Oil Return
*	810-3014	Tube, Front Oil Return
*	200-4725	Guard, Probe and High-Limit
*	210-1433	Clamp, Probe and High-Limit Bulb
*	200-4505	Plate, Drain Nipple Closure
*	812-1515	Nipple, 3/8" x 2.345" NPT Toe

\* Not illustrated.

**YSCFC SERIES FLATBOTTOM GAS FRYERS  
CHAPTER 2: PARTS LIST**

**2.10 Drain Valve and Components**

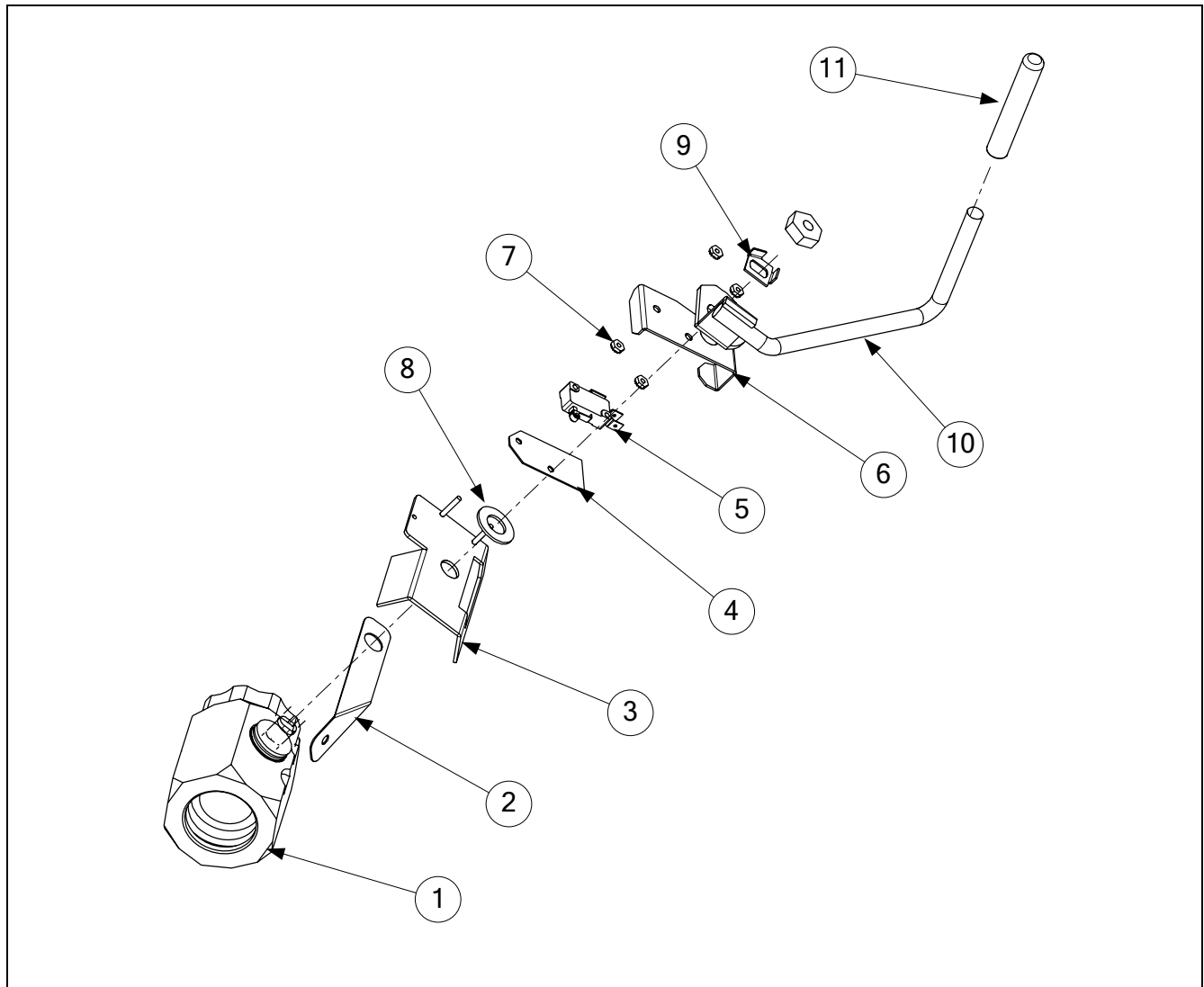

ITEM	PART #	COMPONENT
1	810-2867	Valve, Drain 1 1/4" (1" Std. Port)
2	200-8867	Strap, 3" Drain
3	106-6020	Bracket Assembly
4	816-0220	Insulation
5	807-2103	Switch, Micro CE Straight Lever
6	220-3517	Cover, Safety Switch
7	826-1366	Nut, 4-40 Keps Hex (Pkg. of 25)
8	809-0988	Washer, 1" OD x .525" ID Teflon
9	200-1257	Retainer, Nut, Drain Valve
10	823-4883	Handle, Drain Valve
11	816-0547	Sleeve, Plastic, 1 1/4" Red

**YSCFC SERIES FLATBOTTOM GAS FRYERS  
CHAPTER 2: PARTS LIST**

**2.11 Wiring Connectors, Pin Terminals, and Power Cords**

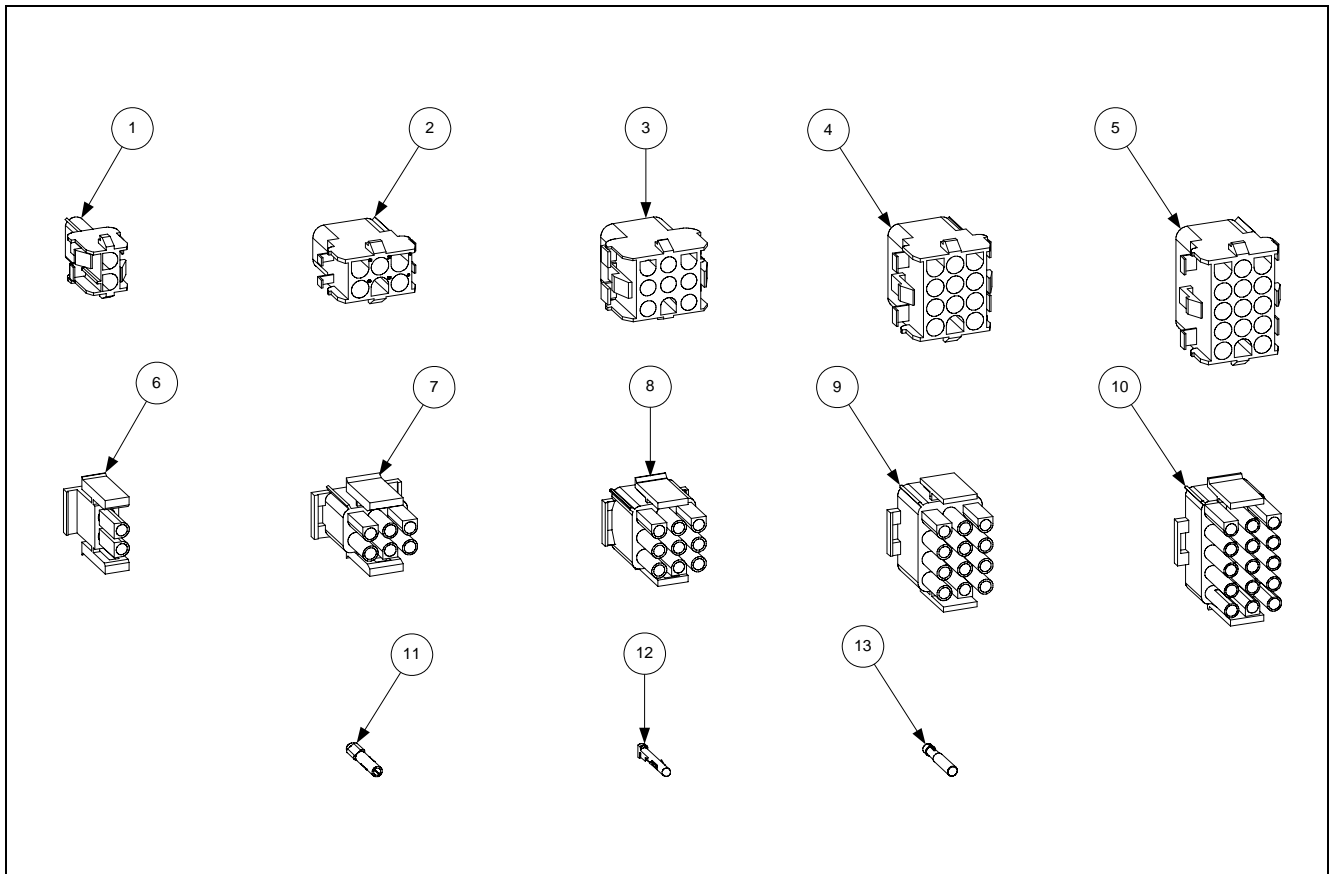

ITEM	PART #	COMPONENT
*	106-7649	Power Cord Assembly 120V 10' 16 gauge
<b>Connectors</b>		
1	807-1068	2-Pin Female
2	807-0158	6-Pin Female
3	807-0156	9-Pin Female
4	807-0159	12-Pin Female
5	807-0875	15-Pin Female
6	807-1067	2-Pin Male
7	807-0157	6-Pin Male
8	807-0155	9-Pin Male
9	807-0160	12-Pin Male
10	807-0804	15-Pin Male
11	826-1341	Terminal, Female Split Pin (Pkg. of 25)
12	826-1342	Terminal, Male Split Pin (Pkg. of 25)
13	807-2518	Plug, Mate-N-Lock (Dummy Pin)

\* Not illustrated.



**YSCFC SERIES FLATBOTTOM GAS FRYERS  
CHAPTER 2: PARTS LIST**

---

**2.12 Screws, Nuts, and Fasteners**

ITEM	PART #	COMPONENT
*	826-1389	Screw, ¼-20 x ¾" (Pkg. of 10)
*	826-1359	Screw, 4-40 x ¾" Slotted Round Head (Pkg. of 25)
*	809-0853	Screw, 10-32 x 1.5" Slotted Pan Head
*	809-0839	Screw, 8-32 x .75" Slotted Pan Head
*	809-0918	Screw, 10-24 x ½"
*	826-1371	Screw, #8 x .50" Slotted Hex Head (Pkg. of 25)
*	826-1374	Screw, #10 - ½" Hex Washer Head (Pkg. of 25)
*	809-0766	Nut, 10-32 Hex Head
*	809-0823	Nut, ¼-20 Nylock
*	809-0247	Nut, 8-32 Keps
*	809-0834	Nut, 8-32 Hex Locknut
*	809-0050	Nut, 8-32 Hex Zinc Plated
*	826-1366	Nut, 4-40 Keps (Pkg. of 25) (used to mount microswitch)
*	826-1362	Nut, ¼-20 Hex, Zinc Plated
*	809-0987	Nut, ¼-20 Press, Stainless Steel
*	809-0885	Washer, Flat ⅜" x 1" x .083"
*	809-0191	Washer, ¼" Lock

\* Not illustrated.



Frymaster/Dean, 8700 Line Avenue, Shreveport, Louisiana 71106

TEL 1-318-865-1711

FAX (Parts) 1-318-688-2220

FAX (Tech Support) 1-318-219-7135

PRINTED IN THE UNITED STATES

SERVICE HOTLINE  
1-800-551-8633

819-6472  
FEB 2009