



45 Series Gas Fryers

Service & Parts Manual



CFESA
Commercial Food Equipment Service Association

Frymaster, a member of the Commercial Food Equipment Service Association, recommends using CFESA Certified Technicians.

24-Hour Service Hotline 1-800-551-8633

NOVEMBER 2003

*** 8195665 ***

NOTICE

IF, DURING THE WARRANTY PERIOD, THE CUSTOMER USES A PART FOR THIS ENODIS EQUIPMENT OTHER THAN AN UNMODIFIED NEW OR RECYCLED PART PURCHASED DIRECTLY FROM FRYMASTER/DEAN, OR ANY OF ITS AUTHORIZED SERVICE CENTERS, AND/OR THE PART BEING USED IS MODIFIED FROM ITS ORIGINAL CONFIGURATION, THIS WARRANTY WILL BE VOID. FURTHER, FRYMASTER/DEAN AND ITS AFFILIATES WILL NOT BE LIABLE FOR ANY CLAIMS, DAMAGES OR EXPENSES INCURRED BY THE CUSTOMER WHICH ARISE DIRECTLY OR INDIRECTLY, IN WHOLE OR IN PART, DUE TO THE INSTALLATION OF ANY MODIFIED PART AND/OR PART RECEIVED FROM AN UNAUTHORIZED SERVICE CENTER.

NOTICE

This appliance is intended for professional use only and is to be operated by qualified personnel only. A Frymaster/DEAN Factory Authorized Service Center (FASC) or other qualified professional should perform installation, maintenance, and repairs. Installation, maintenance, or repairs by unqualified personnel may void the manufacturer's warranty. See Chapter 1 of this manual for definitions of qualified personnel.

NOTICE

This equipment must be installed in accordance with the appropriate national and local codes of the country and/or region in which the appliance is installed. See NATIONAL CODE REQUIREMENTS in Chapter 2 of this manual for specifics.

NOTICE TO U.S. CUSTOMERS

This equipment is to be installed in compliance with the basic plumbing code of the Building Officials and Code Administrators International, Inc. (BOCA) and the Food Service Sanitation Manual of the U.S. Food and Drug Administration.

NOTICE

Drawings and photos used in this manual are intended to illustrate operational, cleaning and technical procedures and may not conform to onsite management operational procedures.

NOTICE TO OWNERS OF UNITS EQUIPPED WITH COMPUTERS

U.S.

This device complies with Part 15 of the FCC rules. Operation is subject to the following two conditions: 1) This device may not cause harmful interference, and 2) This device must accept any interference received, including interference that may cause undesired operation. While this device is a verified Class A device, it has been shown to meet the Class B limits.

CANADA

This digital apparatus does not exceed the Class A or B limits for radio noise emissions as set out by the ICES-003 standard of the Canadian Department of Communications.

Cet appareil numérique n'émet pas de bruits radioélectriques dépassant les limites de classe A et B prescrites dans la norme NMB-003 édictée par le Ministre des Communications du Canada.

DANGER

Improper installation, adjustment, maintenance or service, and unauthorized alterations or modifications can cause property damage, injury, or death. Read the installation, operating, and service instructions thoroughly before installing or servicing this equipment. Only qualified service personnel may convert this appliance to use a gas other than that for which it was originally configured.

⚠ DANGER

Adequate means must be provided to limit the movement of this appliance without depending upon the gas line connection. Single fryers equipped with legs must be stabilized by installing anchor straps. All fryers equipped with casters must be stabilized by installing restraining chains. If a flexible gas line is used, an additional restraining cable must be connected at all times when the fryer is in use.

⚠ DANGER

The front ledge of the fryer is not a step! Do not stand on the fryer. Serious injury can result from slips or contact with the hot oil.

⚠ DANGER

Do not store or use gasoline or other flammable liquids or vapors in the vicinity of this or any other appliance.

⚠ DANGER

Instructions to be followed in the event the operator smells gas or otherwise detects a gas leak must be posted in a prominent location. This information can be obtained from the local gas company or gas supplier.

⚠ DANGER

The crumb tray in fryers equipped with a filter system must be emptied into a fireproof container at the end of frying operations each day. Some food particles can spontaneously combust if left soaking in certain shortening material.

⚠ WARNING

Do not bang fry baskets or other utensils on the fryer's joiner strip. The strip is present to seal the joint between the fry vessels. Banging fry baskets on the strip to dislodge shortening will distort the strip, adversely affecting its fit. It is designed for a tight fit and should only be removed for cleaning.

45 SERIES GAS FRYERS SERVICE AND PARTS MANUAL

TABLE OF CONTENTS

CHAPTER 1: Service Procedures

| | | |
|--------|--|------|
| 1.1 | Functional Description..... | 1-1 |
| | Pilot Ignition System..... | 1-1 |
| | Control Options..... | 1-1 |
| | Interface Boards..... | 1-1 |
| | Thermostats and Temperature Probes..... | 1-3 |
| 1.2 | Accessing Fryers for Servicing..... | 1-4 |
| 1.3 | Checking the Burner Manifold Gas Pressure..... | 1-4 |
| 1.4 | Adjusting the Pilot Flame..... | 1-5 |
| 1.5 | Cleaning the Gas Valve Vent Tube..... | 1-6 |
| 1.6 | Adjusting Burner Ceramic Target Spacing and Alignment..... | 1-6 |
| 1.7 | Calibrating the Thermostat Control..... | 1-6 |
| 1.8 | Replacing Fryer Components..... | 1-7 |
| 1.8.1 | Replacing the Controller or Computer..... | 1-7 |
| 1.8.2 | Replacing the Operating Thermostat..... | 1-8 |
| 1.8.3 | Replacing the Temperature Probe..... | 1-8 |
| 1.8.4 | Replacing the Hi-Limit Thermostat in Fryers with Thermostat Controls..... | 1-9 |
| 1.8.5 | Replacing the Hi-Limit Thermostat in Fryers with Other Than Thermostat Controls..... | 1-10 |
| 1.8.6 | Replacing the Heat Mode Indicator Light in Fryers with Thermostat Controls..... | 1-10 |
| 1.8.7 | Replacing the Power or Melt Cycle Switch in Fryers with Thermostat Controls..... | 1-11 |
| 1.8.8 | Replacing the Melt Cycle Timer in Fryers with Thermostat Controls..... | 1-11 |
| 1.8.9 | Replacing Burner Ceramic Targets..... | 1-12 |
| 1.8.10 | Replacing the Gas Valve..... | 1-12 |
| 1.8.11 | Replacing the Pilot Assembly or Thermopile..... | 1-13 |
| 1.8.12 | Replacing the Frypot..... | 1-14 |
| 1.9 | Troubleshooting and Problem Isolation..... | 1-15 |
| 1.9.1 | Ignition Failures..... | 1-16 |
| 1.9.2 | Improper Burner Functioning..... | 1-17 |
| 1.9.3 | Improper Temperature Control..... | 1-18 |
| 1.9.4 | Computer-Related Problems..... | 1-19 |
| 1.9.5 | Filtration Problems..... | 1-20 |
| 1.9.6 | Leakage Problems..... | 1-22 |
| 1.9.7 | Basket Lift Malfunctions..... | 1-22 |
| 1.9.8 | Interpretation of Digital Controller Lights..... | 1-28 |
| 1.10 | Troubleshooting Guides..... | 1-28 |
| 1.10.1 | Troubleshooting the 24 VAC Circuit in Units without Interface Boards..... | 1-29 |
| 1.10.2 | Troubleshooting the 24 VAC Circuit in Units with Interface Boards..... | 1-30 |
| 1.10.3 | Troubleshooting the Gas Valve..... | 1-32 |
| 1.10.4 | Troubleshooting the Thermostat..... | 1-33 |
| 1.10.5 | Troubleshooting the Temperature Probe..... | 1-34 |
| | Probe Resistance Chart..... | 1-35 |
| 1.11 | Wiring Diagrams..... | 1-36 |

CHAPTER 2: Parts List

| | |
|---|------|
| Accessories | 2-1 |
| Basket Lift Assemblies and Component Parts..... | 2-2 |
| Bell Crank Basket Lift..... | 2-2 |
| Modular Basket Lift | 2-4 |
| Burner Assembly Component Parts..... | 2-6 |
| Cabinet Assemblies and Component Parts | 2-8 |
| Fryer and Spreader Cabinet Assembly Components..... | 2-8 |
| Filter Magic II Add-On Cabinet Components..... | 2-12 |
| Casters, Legs, and Associated Hardware..... | 2-14 |
| Component Shield and Filter Box Assemblies and Component Parts..... | 2-15 |
| Control Panel Assemblies, Flue Caps, Top Caps, and Related Items..... | 2-20 |
| Controller Assemblies (Thermostat Controllers)..... | 2-22 |
| Controller Assemblies (Other than Thermostat Controllers)..... | 2-24 |
| Door Assembly | 2-25 |
| Drain and Filtration System Components..... | 2-26 |
| Filter Magic II Square Drain Components | 2-26 |
| Filter Magic II Filter Pan Assemblies | 2-28 |
| Frypot Assemblies and Component Parts | 2-29 |
| Oil Return Plumbing and Handle Assemblies | 2-30 |
| Power Shower Assembly | 2-33 |
| Temperature Probe, Thermostats, and Related Components..... | 2-34 |
| Wiring Assemblies/Harnesses and Remote Cable Assemblies | 2-35 |
| Wiring Connectors, Pin Terminals, and Power Cords..... | 2-36 |

THIS PAGE INTENTIONALLY LEFT BLANK.

45 SERIES GAS FRYERS SERVICE AND PARTS MANUAL

CHAPTER 1: SERVICE PROCEDURES

1.1 Functional Description

The 45 Series fryers contain a welded steel (stainless or cold rolled) frypot that is directly heated by gas flames that are diffused evenly over its lower surface by ceramic targets.

The flames originate from orifices in a U-shaped burner manifold positioned beneath the frypot. The orifice diameters differ for natural and propane gas as indicated in the table below (see Page 2-7 for a complete list of available orifices).

| 45 Series Orifice Sizes (0-1999 ft/609 m) | | |
|---|--------|-------------|
| Gas | Inches | Millimeters |
| Natural | 0.057 | 1.45 |
| Propane | 0.034 | 0.86 |

Gas flow to the manifold is regulated by an electromechanical gas valve. This series of fryers is equipped with a 24-volt gas valve and all models use a pilot ignition system.

PILOT IGNITION SYSTEM

The pilot ignition system is comprised of the pilot orifice, pilot hood, and a thermopile. The pilot serves two purposes. The first is to light the burner, the second is to heat the thermopile. In operation, the thermopile is in contact with the pilot flame and generates millivolts. The millivolt output passes through a normally closed high-limit switch and energizes the gas valve pilot coil, which in turn opens the pilot valve. If the pilot flame is extinguished, voltage is lost to the gas valve pilot coil and the pilot valve closes. A separate 24-volt circuit, activated by the fryer ON/OFF switch, provides voltage through the thermostat or controller to the gas valve main coil, which opens the main valve. The gas valve is constructed so that the main valve will not open if the pilot valve is not open. The pilot flame must be manually lit (either with a match or with an optional built-in piezo igniter) when the fryer is first placed into operation.

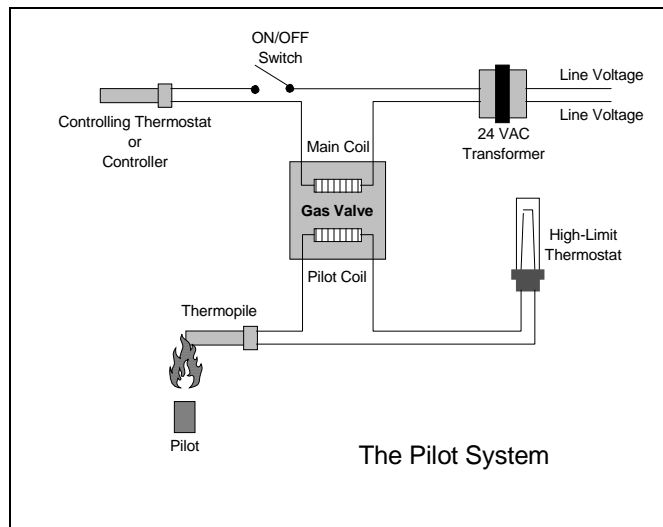

CONTROL OPTIONS

45 Series fryers may be equipped with thermostat controllers, analog controllers, digital controllers, basket lift timers, or Computer Magic computers.

In fryers equipped with thermostat controls, the fryer and melt cycle are turned on and off by means of rocker switches and the temperature is set by means of a knob connected directly to the frypot-mounted thermostat. These units have no interface board. In this type of unit, when the melt cycle switch is placed in the ON position, the fryer stays in the melt cycle mode until the switch is manually placed in the OFF position, even if the frypot is at setpoint temperature.

Fryers equipped with other types of controllers have an interface board located in the component shield behind the control panel.

INTERFACE BOARDS

The interface board provides the link between the controller/computer and the fryer's individual components without requiring excessive wiring, and allows the controller to execute commands from one central point. When built, depending upon the configuration of the particular fryer, any one of three different boards may be used. *Regardless of the particular board installed when the fryer was built, P/N 806-3548 is the universal replacement part.*

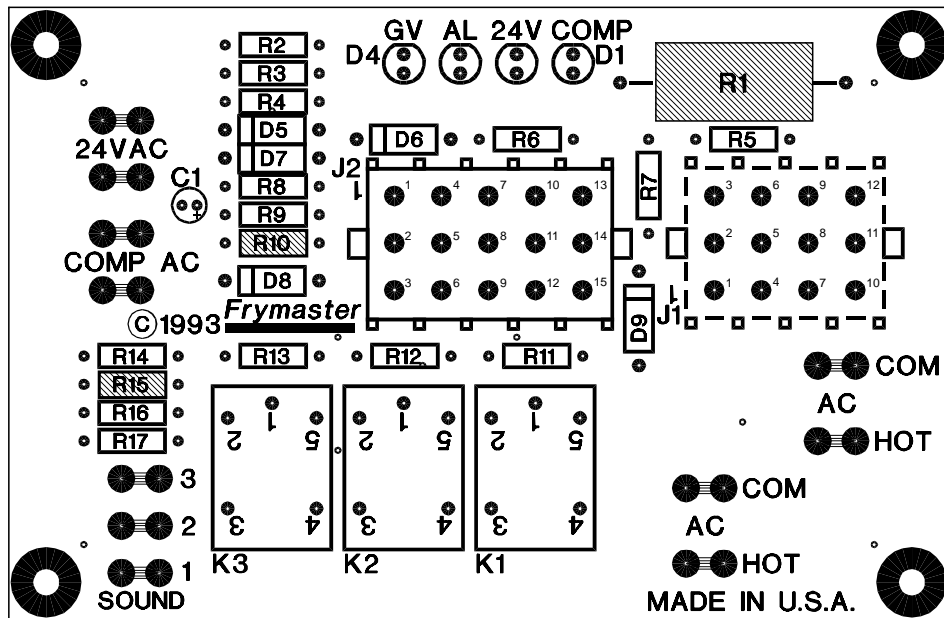

NOTES:

1. RELAYS K1 AND K2 ARE FOR BELL CRANK BASKET LIFTS. THEY ARE NOT PRESENT ON BOARDS 806-5490 (U.S. AND NON-CE EXPORT UNITS W/O BASKET LIFTS) OR 806-7501 (CE UNITS, WITH OR WITHOUT BASKET LIFTS).
2. RESISTORS R1, R10, AND R15 ARE NOT USED ON ANY OF THE THREE BOARDS.
3. RESISTORS R11 AND R12 ARE NOT USED ON 806-5490 BOARDS.

INTERFACE BOARDS [806-3548](#), [806-5490](#), AND [806-7505](#)

| FREQUENTLY USED TEST POINTS FOR 45 SERIES INTERFACE BOARDS | | | |
|---|---------------|--------------------|---------|
| Test | Meter Setting | Pins | Results |
| 12 VAC Power to Controller | 50 VAC Scale | 1 and 3 of J2 | 12-18 |
| 24 VAC Power | 50 VAC Scale | 24 VAC Terminals | 22-28 |
| 24 VAC Power to Gas Valve | 50 VAC Scale | 6 on J1 and GROUND | 22-28 |
| 120 VAC Power | 250 VAC Scale | 7 and 12 of J1 | 110-125 |
| Probe Resistance* | R x 1000 OHMS | 2 and 3 of J1 | ** |
| * Disconnect 15-Pin harness from controller before testing probe circuit. | | | |
| ** See Probe Resistance Chart at end of chapter. | | | |

Four LEDs, arranged across the top of the boards and identified in the table below, are provided to assist in troubleshooting.

| 45 SERIES INTERFACE BOARD LED DIAGNOSTIC LIGHTS | |
|--|---|
| GV | Indicates 24 VAC to the gas valve |
| AL | Indicates open Drain Safety Switch (if installed) |
| 24V | Indicates 24 VAC from transformer |
| COMP | Indicates 12 VAC to computer |

Every board contains one heat relay (K3), and may contain two basket lift relays (K1 and K2). As shipped from the factory, fryers with bell crank basket lifts will have relays K1, K2, and K3. All other factory-original fryers will have boards with only relay K3.

THERMOSTATS AND TEMPERATURE PROBES

Different types of thermostats are used in 45 Series fryers, depending on the fryers' configuration.

Fryers equipped with Thermostat Controls have an adjustable *controlling (operating) thermostat*. The temperature at which the thermostat opens and closes is adjusted by physically changing the setting of the thermostat itself by means of an attached knob. When new, the Fenwal controlling thermostat used in 45 Series fryers is sensitive to one-degree changes in temperature.

 **CAUTION**

Fenwal thermostats are used in a number of *Frymaster* products. The thermostat for the 45 Series is 4 inches long. Do not use 3-inch Fenwal thermostats in 45 Series fryers.

Fryers equipped with all other type controls have a *temperature probe*. In these units, the probe resistance varies directly with the temperature. That is, as the temperature rises, so does resistance at a rate of approximately 2 ohms for every 1° (F or C). Circuitry in the controller monitors the probe resistance and controls burner firing when the resistance exceeds or falls below programmed temperatures (setpoints). The temperatures are programmed by means of a keypad on the face of the controller.

All 45 Series fryers are equipped with a *high-limit thermostat*. In the event that the fryer fails to properly control the oil temperature, the high-limit thermostat prevents the fryer from overheating to the flash point. The high-limit thermostat acts as a normally closed power switch that opens when

exposed to temperatures in the range of 425°F to 450°F (218°C to 232°C). The high-limit thermostat is the same for CE and Non-CE applications, but the terminals for attaching it to Robertshaw and Honeywell gas valves differ. When a replacement high-limit thermostat is ordered, make sure the kit appropriate for the valve in use is ordered.

1.2 Accessing Fryers for Servicing

DANGER

Moving a fryer filled with cooking oil/shortening may cause spilling or splattering of the hot liquid. Follow the draining instructions in Chapter 4 of the 45 Series Gas Fryer Installation and Operation Manual before attempting to relocate a fryer for servicing.

1. Shut off the gas supply to the unit. Unplug the power cord(s). Disconnect the unit from the gas supply.
2. Remove any attached restraining devices.
3. Relocate the fryer for service accessibility.
4. After servicing is complete, reconnect the unit to the gas supply, reattach restraining devices, and plug in the electrical cords.

1.3 Checking the Burner Manifold Gas Pressure

WARNING

This task should be performed by qualified service personnel only.

1. Ensure that the gas valve knob or button is in the OFF position.
2. Remove the pressure tap plug from the end of the manifold (see illustration below for location) and connect a gas pressure-measuring device to the port.

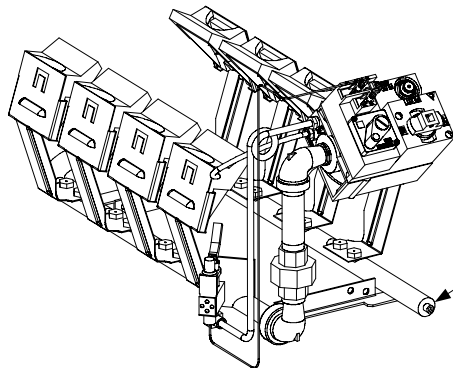

Remove this plug and connect a gas pressure-measuring device to the port.

3. Place the gas valve in the ON position then place the fryer power switch in the ON position. When the burner lights and continues to burn, compare the pressure reading to that for the corresponding gas in the tables on the following page.

| Non-CE Standard Burner Manifold Gas Pressures | |
|--|------------------------|
| Gas | Pressure |
| Natural | 3.5" W.C. 0.73 kPa |
| Propane | 8.25" W.C. 2.05 kPa |

| CE Standard Burner Manifold Gas Pressures | |
|--|-----------------|
| Gas | Pressure (mbar) |
| Natural Gas Lacq (G20) under 20 mbar | 7,5 |
| Natural Gas Gronique * (G25) under 25 mbar | 10 |
| Natural Gas Gronique (G20) under 20 mbar | 10 |
| Propane (G31) under 37 or 50 mbar | 20,6 |

* Belgian G25 = 7,0 mbar

4. If the measured gas pressure does not match the appropriate pressure in the tables above, remove the cap from the gas valve regulator and adjust to the correct pressure.

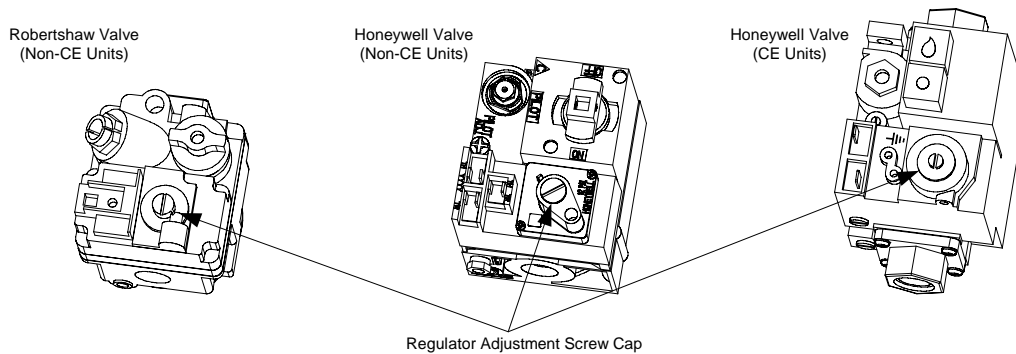

5. Place the fryer power switch and the gas valve in the OFF position. Remove the fitting from the pressure tap hole and reinstall the plug. Place the gas valve in the ON position, and check for and eliminate any gas leaks. Place the gas valve in the OFF position.

1.4 Adjusting the Pilot Flame

1. On non-CE valves, remove the cap covering the pilot adjustment screw. On all valves, turn the pilot adjustment screw counterclockwise to increase the length of the flame or clockwise to decrease the length of the flame. Adjust the flame to a length of 1 to 1½ inches (25 to 38mm).

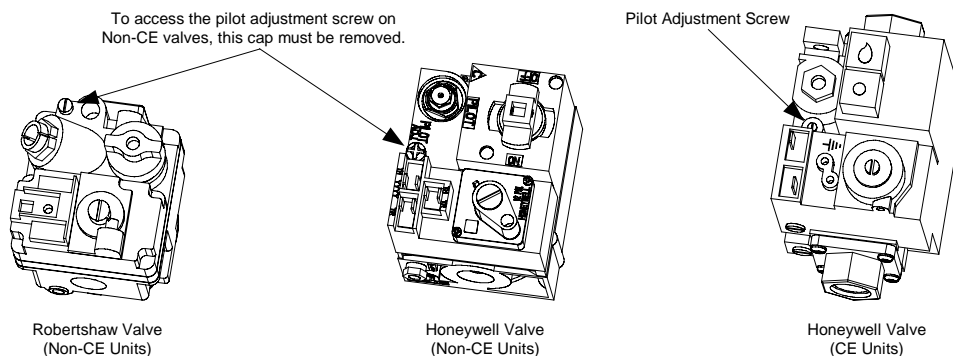

2. On Non-CE valves, reinstall the pilot adjustment screw cap.

1.5 Cleaning the Gas Valve Vent Tube

1. Carefully unscrew the vent tube from the gas valve. **NOTE:** The vent tube may be straightened for ease in removal.
2. Pass a piece of ordinary binding wire (.052 inch diameter) or equivalent through the tube to remove any obstruction.
3. Remove the wire, then blow through the tube to ensure it is clear.
4. Reinstall tube and bend it so that the opening is pointing downward.

1.6 Adjusting Burner Ceramic Target Spacing and Alignment



DANGER

Drain the frypot or remove the handle from the drain valve before proceeding further.

Proper spacing of the top edge of the burner ceramic targets is $\frac{3}{4}$ inch (13 mm) from the frypot side. To adjust target spacing, bend the brackets to which they are attached away or toward the frypot to the proper distance. (A length of board of the proper thickness is useful as a gauge to verify spacing and alignment.)

1.7 Calibrating the Thermostat Control

NOTE: The fryer control panel must be hinged down from the control panel mounting frame to perform thermostat calibration. In order to hinge the control panel down, the thermostat knob must be removed from its shaft. It is secured with a setscrew located opposite the index mark on the knob.

1. Fill the frypot to the lower OIL-LEVEL line with cooking oil/shortening. If solid shortening is used, it must be pre-melted before starting the calibration procedure.
2. Ensure the fryer ON/OFF Switch is in the OFF position, then light the pilot. (Refer to Chapter 3 of the 45 Series Gas Fryer Installation and Operation Manual for detailed lighting instructions.)
3. Insert a good grade thermometer or pyrometer into the frypot so that it touches the thermostat guard.
4. Loosen the setscrew and stop screw securing the thermostat shaft extension to the flexible shaft. Remove the extension to expose the slot in the end of the flexible shaft.
5. Place the fryer ON/OFF switch in the ON position.

NOTE: If the burner does not light at this time, it does not mean the thermostat is defective!

Use a small flat-tipped screwdriver to slowly turn the flexible shaft **counterclockwise** until the burner lights. *Turning the shaft counterclockwise causes the burner to light and clockwise causes it to shut off.*

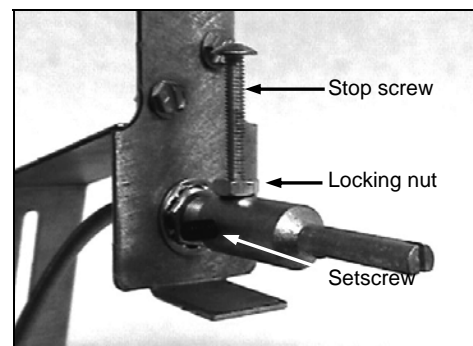

6. When the cooking oil/shortening temperature reaches 325°F (162°C), turn the flexible shaft slowly clockwise until the burner shuts off.
7. Allow the fryer to sit for a few minutes, then slowly turn the flexible shaft **counterclockwise** until the burner lights.
8. Repeat steps 6 and 7 at least three times to ensure an accurate setting is obtained. The Thermostat Control is considered to be properly calibrated when the burner lights as the cooking oil/shortening cools to 325°F (162°C)—not when the burner shuts off as the temperature rises.
9. Once the calibration point of 325°F (162°C) is determined, allow the burner to cycle on and off at least 3 times to be sure it will light at the calibrated temperature.
10. After the calibration is complete, place the fryer power switch in the OFF position and disconnect the fryer from the electrical supply.
11. Carefully replace the thermostat shaft extension, ensuring that the stop screw is pointed straight up. Tighten the stop screw and locking nut and the setscrew, being careful not to rotate the flexible shaft.

⚠ CAUTION

The thermostat flexible shaft must not be rotated while installing the thermostat shaft extension!

When handling the thermostat, do not rotate the shaft more than two turns in either direction. Doing so will cause damage to the thermostat.

12. Close the fryer control panel and replace the screws the upper corners.
13. Reinstall the thermostat knob with its pointer aligned with the 325°F (162°C) index mark on the temperature dial.
14. Reconnect the fryer to the electrical supply.

1.8 Replacing Fryer Components

1.8.1 Replacing the Controller or Computer

1. Disconnect the fryer from the electrical power supply.
2. Unscrew the two control panel screws. The control panel is hinged at the bottom and will swing open from the top.
3. Unplug the fryer wiring harness from the back of the controller/computer and disconnect the grounding wire.

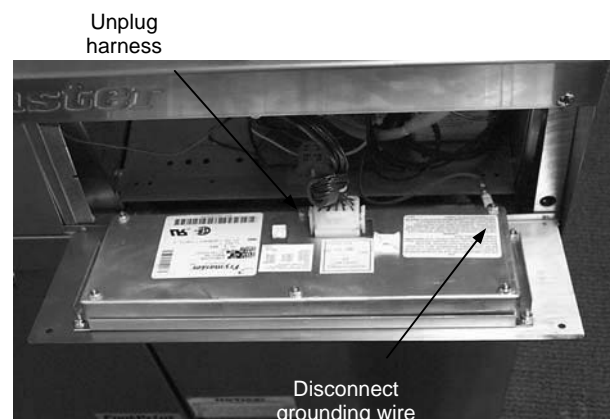

4. Remove the controller/computer by lifting it from the hinge slots in the fryer control panel frame.
5. Reverse the procedure to install a new controller/computer.

1.8.2 Replacing the Operating Thermostat

⚠ CAUTION

The thermostat must be calibrated after installation is complete. Refer to Section 1.7 for calibration instructions.
When handling the thermostat, do not rotate the shaft more than two turns in either direction. Doing so will cause damage to the thermostat.

1. Disconnect the fryer from the electrical supply and drain the frypot.
2. Loosen the setscrew securing the thermostat knob and remove the knob. Remove the screws from the upper left and right corners of the control panel. The control panel is hinged at the bottom and will swing open from the top.
3. Disconnect the 9-Pin connector and remove the control panel from the fryer by disengaging its tabs from the hinge slots in the mounting frame.
4. Loosen the setscrews securing the flexible shaft to the thermostat shaft and slip the flexible shaft off the thermostat shaft.
5. Remove the flexible shaft guide by removing the two sheet metal screws securing it to the upper frame.
6. Disconnect the thermostat leads from Pin 14 in the 20-pin terminal block and from the gas valve terminal.



NOTE: If the fryer is configured with a melt cycle, the thermostat leads will be connected to the melt cycle timer motor or PC board rather than to the terminal block and gas valve. Disconnect the leads from the motor or PC board if this is the case.

7. Unscrew the thermostat from the frypot and remove.
8. Apply Loctite™ PST56765 thread sealant or equivalent to the replacement thermostat threads.
9. Reverse steps 1 through 7 to install the replacement.

1.8.3 Replacing the Temperature Probe

1. Disconnect the fryer from the electrical supply.

2. Drain the frypot.
3. Remove the screws from the upper left and right corners of the control panel. The panel is hinged at the bottom and will swing open from the top.
4. Unplug the wiring harness from the back of the controller and disconnect the grounding wire.
5. Remove the controller from the fryer by lifting it from the hinge slots in the control panel frame.

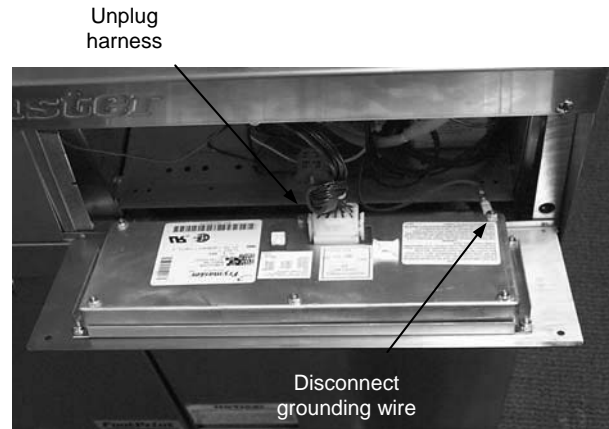

6. Remove the two screws from the base of the interface board mounting bracket.
7. Disconnect the 12-pin plug from the back of the interface board and lay the board in the left end of the compartment with all other wires still connected.
8. Remove the 12-volt transformer from the component shield and lay it in the left end of the compartment with wires still connected.
9. Using a pin-pusher, remove the temperature probe wires (pins 1 and 2) from the 12-pin plug disconnected in step 7.
10. Unscrew the temperature probe from the frypot and remove.
11. Apply Loctite™ PST56765 thread sealant or equivalent to new probe threads.
12. Reverse steps 1 through 10 to install the replacement probe.

1.8.4 Replacing the High-Limit Thermostat in Fryers with Thermostat Controls

1. Disconnect the fryer from the electrical supply.
2. Drain the frypot.
3. Loosen the setscrew securing the thermostat knob and remove the knob. Remove the screws from the upper left and right corners of the control panel. The control panel is hinged at the bottom and will swing open from the top.
4. Disconnect the 9-Pin connector and remove the control panel from the fryer by disengaging its tabs from the hinge slots in the mounting frame.
6. Disconnect the high-limit thermostat leads from the gas valve pilot coil.
7. Unscrew the high-limit thermostat from the frypot and remove.
8. Apply Loctite™ PST56765 thread sealant or equivalent to the replacement thermostat threads.
9. Reverse steps 1 through 7 to install the replacement.

1.8.5 Replacing the High-Limit Thermostat in Fryers with Other Than Thermostat Controls

1. Disconnect the fryer from the electrical power supply.
2. Drain the frypot.
3. Remove the screws from the upper left and right corners of the controller panel. The controller is hinged at the bottom and will swing open from the top.
4. Unplug the wiring harness and disconnect the grounding wire from the the controller.

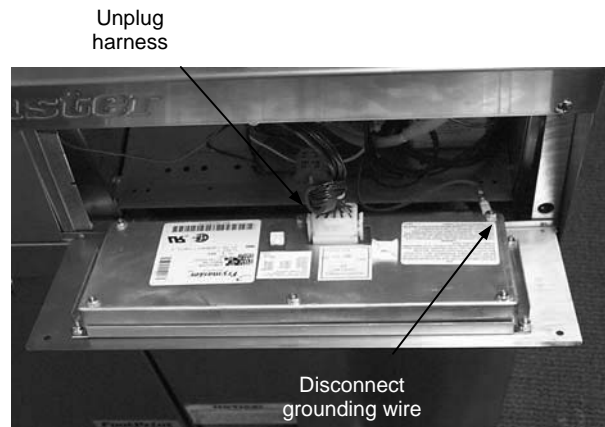

5. Remove the controller from the fryer by lifting it from the hinge slots in the fryer control panel frame.
6. Remove the two screws from the base of the interface board mounting bracket.
7. Disconnect the 12-pin plug from the back of the interface board and lay the board in the right end of the compartment with all other wires still connected.
8. Remove the 12-volt transformer and lay it in the right end of the compartment with wires still connected.
9. Remove the high-limit thermostat wires from the gas valve pilot coil and pull them up through the control shield.
10. Unscrew the high-limit thermostat from the frypot and remove.
11. Apply Loctite™ PST56765 thread sealant or equivalent to the replacement thermostat's threads and screw it into the frypot.
12. Attach the appropriate terminals (furnished in the replacement thermostat kit) to the thermostat leads.
13. Reverse steps 1 through 9 to complete installation of the replacement thermostat.

1.8.6 Replacing the Heat Mode Indicator Light in Fryers with Thermostat Controls

1. Disconnect the fryer from the electrical supply.
2. Loosen the setscrew securing the thermostat knob and remove the knob. Remove the screws from the upper left and right corners of the control panel. The control panel is hinged at the bottom and will swing open from the top.

3. Disconnect the 9-pin connector and remove the control panel from the fryer by disengaging its tabs from the hinge slots in the mounting frame.
4. Carefully press the light out from the back of the control panel. Disconnect one wire at a time and reconnect it to the replacement light until all wires are transferred.
5. Carefully press the light back into the control panel.
6. Reverse steps 1-3 to reassemble the fryer.

1.8.7 Replacing the Power or Melt Cycle Switch in Fryers with Thermostat Controls

1. Disconnect the fryer from the electrical supply.
2. Loosen the setscrew securing the thermostat knob and remove the knob. Remove the screws from the upper left and right corners of the control panel. The control panel is hinged at the bottom and will swing open from the top.
3. Disconnect the 9-pin connector and remove the control panel from the fryer by disengaging its tabs from the hinge slots in the mounting frame.
4. Using a flat-tipped screwdriver, disconnect the chrome bezel from the tabs on the switch and press the switch out from the front.
5. Carefully press the new switch back into the chrome bezel, making sure the tabs on the switch engage the slots in the bezel.
6. Disconnect one wire at a time from the old switch and reconnect it to the new switch until all wires have been transferred.
7. Reverse steps 1-3 to reassemble the fryer.

1.8.8 Replacing the Melt Cycle Timer in Fryers with Thermostat Controls

NOTE: In early 1999, PC board melt cycle timers replaced melt cycle timer motors in new fryers.

1. Disconnect the fryer from the electrical supply.
2. Loosen the setscrew securing the thermostat knob and remove the knob. Remove the screws from the upper left and right corners of the control panel. The control panel is hinged at the bottom and will swing open from the top.
3. Remove the screws securing the timer motor (or the PC board timer bracket) to the fryer (see illustration on Page 2-16).
4. Remove one wire at a time and reconnect it to the replacement PC board timer until all wires have been transferred.
5. Reverse steps 1-3 to reassemble the fryer.

1.8.9 Replacing Burner Ceramic Targets



Drain the frypot or remove the handle from the drain valve before proceeding further.

1. Disconnect fryer from electrical and gas supplies.
2. On FM45 fryers, remove square-drain sections as necessary to expose burner.
3. Disconnect the wires from the gas valve terminal block, marking each wire to facilitate recon-nections.
4. Remove the high-limit thermostat wires from the gas valve pilot coil.
5. Disconnect the pipe union collar at the right side of the gas valve.
6. Remove the burner heat shield hanger screws at the front of the burner and remove the heat shield.
7. Remove the burner hanger screws and lower the front of the main burner. Pull it forward to clear the rear burner hanger, then lower the burner to the floor.
8. Raise the front of the fryer enough to slide the burner from under the fryer cabinet.
9. To replace only the ceramic targets, straighten the target locking tabs with a pair of needle nose pliers or a screwdriver, and slide the target up and off the bracket. Slide the replacement target onto the bracket and bend the locking tabs down.

To replace the entire target assembly, use a ½-inch (13mm) box end wrench to remove the two brass orifices that hold the assembly to the burner manifold. Position the new assembly and re-
place the orifices.



Use extreme care to prevent cross-threading and stripping when reinstalling the brass orifices.

10. Reverse steps 1-8 to reinstall the burner assembly. Check spacing and alignment of targets in accordance with Section 1.5.

1.8.10 Replacing the Gas Valve



Drain the frypot or remove the handle from the drain valve before proceeding further.

1. Disconnect fryer from electrical and gas supplies

2. Disconnect the wires from the gas valve terminal block, marking each wire to facilitate recon-nections.
3. Remove the high-limit thermostat wire from the gas valve pilot coil.
4. Disconnect the pilot gas line fitting from the gas valve.
5. Disconnect the pipe union collars to the left and right of the gas valve and remove the valve.
6. Remove the pipe fittings from the old gas valve and install on the replacement valve, using Loc-tite™ PST56765 or equivalent pipe thread sealant on threads.
7. Reverse steps 1-5 to install the replacement gas valve.

1.8.11 Replacing the Pilot Assembly or Thermopile

⚠ DANGER
Drain the frypot or remove the handle from the drain valve before proceeding further.

1. Remove the burner assembly in accordance with steps 1-8 of Section 1.8.9.

2. To replace only the thermopile:
 - a. Bend the clip at the bottom of the pilot as-sembly and press the thermopile out of the pilot assembly from the top.
 - b. Disconnect the thermopile fitting from the gas valve pilot coil.
 - c. Reverse steps a and b to install the re-placement thermopile.

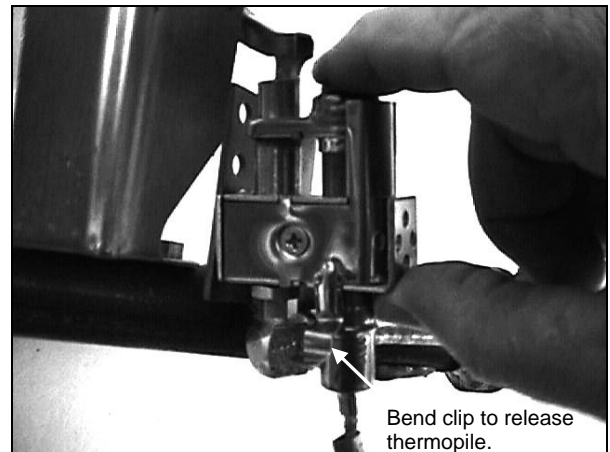

3. To replace the complete pilot assembly:
 - a. Disconnect the pilot tubing from the bottom of the pilot assembly.
 - b. Remove the screw from the pilot mounting bracket to release the pilot assembly.
 - c. Disconnect the thermopile fitting from the gas valve pilot coil.
 - d. Reverse steps a through c to install the replacement pilot assembly.
4. Reinstall the burner assembly by reversing steps 1-8 of Section 1.8.9.

1.8.12 Replacing the Frypot

1. Drain the frypot.
2. Remove all accessories (e.g., frypot covers, basket lift arms, etc.) from the fryer.
3. Disconnect the fryer from gas and electrical supplies.
4. Remove the screws from the top cap above the control panel and lift it up and off the fryer(s).
5. If the fryer is equipped with other than a thermostat control, skip to Step 10.
6. Loosen the setscrew securing the thermostat knob to the thermostat flexible shaft and remove the knob. Remove the screws from the upper left and right corners of the control panel. Disconnect the 9-pin connector and remove the control panel from the fryer.
7. Loosen the setscrews securing the flexible shaft to the thermostat shaft and slip the flexible shaft off the thermostat shaft.
8. Remove the flexible shaft bracket from the fryer by removing the two sheet metal screws securing it to the upper frame.
9. Disconnect the thermostat leads from Pin 14 in the 20-pin terminal block and from the gas valve terminal. Mark each wire to facilitate reconnection. Skip to Step 14.

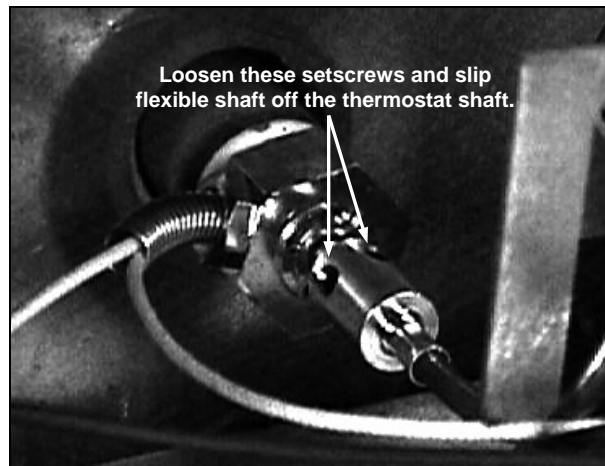

NOTE: If the fryer is configured with a melt cycle, the thermostat leads will be connected to the melt cycle timer **motor** rather than to the terminal block and gas valve. Disconnect the leads from the motor if this is the case.

CAUTION

When handling the thermostat, do not rotate the shaft more than two turns in either direction. Doing so will cause damage to the thermostat.

10. For fryers equipped with other than Thermostat Controls, remove the screws from the upper left and right corners of the control panel. Unplug the wiring harness from the back of the controller and disconnect the grounding wire. Remove it from the fryer by lifting it from the hinge slots in the fryer control frame.
11. Remove the two screws from the base of the interface board bracket.
12. Disconnect the 12-pin plug from the back of the interface board. Use a pin pusher to re-

move the temperature probe leads (pins 1 and

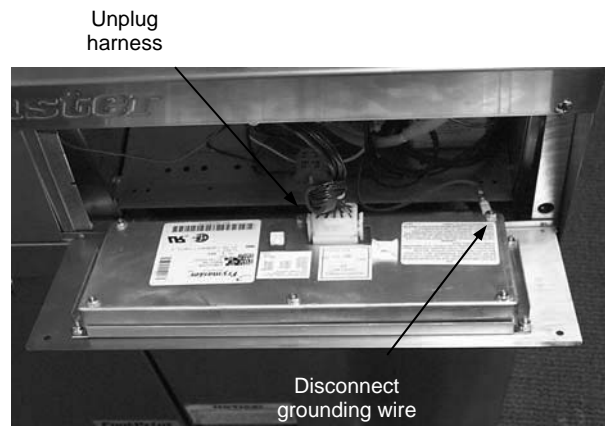

- 2) and the high-limit thermostat leads (pins 6 and 8) from the plug. Leave all other wires connected. Leave the interface board lying on the shield.
13. Remove the louvered frame above the control panel opening.
 14. Remove the screws securing the component shield to the fryer.
 15. Disconnect the wires from components in component shield and mark to facilitate reconnection.
 16. Disconnect the wires from the gas valve terminal block. Mark each wire to facilitate reconnection.
 17. Remove the cover from the safety drain switch, disconnect the wires from the switch, and pull them out of the switch box.
 18. Pull up and forward on the component shield to clear the rear mounting stud on the front of the frypot and remove it from the fryer by rotating its right side up and to the left.
 19. Disconnect the pipe union on the right side of the gas valve.
 20. On FM45 fryers, remove the section of square drain from the drain valve of the frypot to be removed.
 21. Remove the frypot hold down bracket.
 22. Remove the screws from the flue cap sides and back and lift it clear of the fryer(s).
 23. Remove the oil return line from the front of the frypot to be removed.
 24. Lift the complete frypot assembly (frypot, burner, gas valve, and flue) from the fryer cabinet.
 25. Transfer the burner heat shield and burner to the replacement frypot.
 26. Remove the drain valve, thermostat or temperature probe, and high-limit thermostat and install on replacement frypot.

 **CAUTION**

Before installing the thermostat/temperature probe, high-limit thermostat, and drain valve on the replacement frypot, clean their threads and apply Loctite™ PST56765 thread sealant or equivalent to the threads.

27. Reverse steps 1-25 to reassemble the fryer.

1.9 Troubleshooting and Problem Isolation

Because it is not feasible to attempt to include in this manual every conceivable problem or trouble condition that might be encountered, this section is intended to provide technicians with a general knowledge of the broad problem categories associated with this equipment, and the probable causes of each. With this knowledge, the technician should be able to isolate and correct any problem encountered.

Problems you are likely to encounter can be grouped into seven broad categories:

1. Ignition failures
2. Improper burner functioning
3. Improper temperature control
4. Computer-related problems
5. Filtration problems
6. Leakage problems
7. Basket lift malfunctions

The probable causes of each category are discussed in the following sections. A series of Troubleshooting Guides (decision trees) is also included at the end of the chapter to assist in identifying some of the more common problems.

1.9.1 Ignition Failures

Ignition failures occur when the 24VAC power supply to the gas valve is interrupted, when the gas supply is interrupted, or when the pilot flame is extinguished.

Solid-state controllers indicate ignition failure by illuminating the heat light and trouble light simultaneously. All other controllers give no specific indication of an ignition failure.

There are three primary reasons for ignition failure, listed in order of probability:

1. Problems related to the gas and/or electrical power supplies.
2. Problems related to the electronic circuits.
3. Problems related to the gas valve.

PROBLEMS RELATED TO THE GAS AND/OR ELECTRICAL POWER SUPPLIES

The main indicators of this are that an entire battery of fryers fails to light and/or there are no indicator lights illuminated on the fryer experiencing ignition failure. Verify that the quick disconnect hose is properly connected, the fryer is plugged in, the main gas supply valve is open, and the circuit breaker for the fryer electrical supply is not tripped.

PROBLEMS RELATED TO THE ELECTRONIC CIRCUITS

If gas and electrical power are being supplied to the fryer, the next most likely cause of ignition failure is a problem in the 24 VAC circuit of the pilot system. If the fryer is equipped with a Filter Magic II filtration system, first verify that the drain valve is fully closed. (The valve is attached to a microswitch that must be closed for power to reach the gas valve. Often, although the valve handle appears to be in the closed position, the microswitch is still open.) If the valve is fully closed, or the fryer does not have a filtration system, refer to the troubleshooting guides **TROUBLESHOOTING THE 24 VAC CIRCUIT**.

PROBLEMS RELATED TO THE GAS VALVE

If the problem is not in the 24 VAC circuit of the pilot system, it is most likely in the gas valve itself, but before replacing the gas valve refer to **TROUBLESHOOTING THE GAS VALVE** on page 1–32.

1.9.2 Improper Burner Functioning

With problems in this category, the burner ignites but exhibits abnormal characteristics such as “popping,” incomplete lighting of the burner, fluctuating flame intensity, and flames “rolling” out of the fryer.

“**Popping**” indicates delayed ignition. In this condition, the main gas valve is opening but the burner is not immediately lighting. When ignition does take place, the excess gas “explodes” into flame, rather than smoothly igniting.

The primary causes of popping are:

- Incorrect or fluctuating gas pressure
- Misdirected or weak pilot flame
- Burner deflector targets out of alignment or missing
- Clogged burner orifices
- Inadequate make-up air
- Clogged vent tube, causing incorrect gas pressure

If popping occurs only during peak operating hours, the problem may be incorrect or fluctuating gas pressure. Verify that the incoming gas pressure (pressure to the gas valve) is in accordance with the appropriate CE or Non-CE Standard found in the table below, and that the pressure remains constant throughout all hours of usage. Refer to **Checking the Burner Manifold Pressure** (Section 1.3) for the procedure to checking the pressure of gas supplied to the burner.

| Non-CE Standard for Incoming Gas Pressures | | |
|---|------------------------|------------------------|
| Gas | Minimum | Maximum |
| Natural | 6" W.C. | 14" W.C. |
| | 1.49 kPa 14.93 mbar | 3.48 kPa 34.84 mbar |
| LP | 11" W.C. | 14" W.C. |
| | 2.74 kPa 27.37 mbar | 3.48 kPa 34.84 mbar |

| CE Standard for Incoming Gas Pressures | | | | |
|---|--------------------------------|------------------|--------------------|------------------------|
| Gas | Pressure (mbar) ⁽¹⁾ | Orifice Diameter | Regulator Pressure | Consumption |
| G20 | 20 | 18 x 1,40 mm | 7,5 mbar | 3,00 m ³ /h |
| G25 | 20 - 25 | 18 x 1,40 mm | 10 mbar | 3,50 m ³ /h |
| G31 | 37 - 50 | 18 x 0,86 mm | 20,6 mbar | 2,21 kg/h |

(1) mbar = 10,2 mm H²O

If popping is consistent during all hours of operation, verify that the pilot is properly positioned above the burner orifice and that the pilot pressure is correct. Correct pilot pressure is indicated by a flame 1 to 1½” (25 to 38 mm) long. Refer to Section 1.6 for the pilot flame adjustment procedure.

Clogged burner orifices, especially those near the pilot, are also likely causes of delayed ignition. Clogged orifices are indicated by no flame, flames that are orange-colored, and flames that shoot out at an angle from the rest.

Another cause of popping is an insufficient air supply or drafts that are blowing the pilot flame away from the burner. Check for “negative pressure” conditions in the kitchen area. If air is flowing into the kitchen area, this indicates that more air is being exhausted than is being replenished and the burners may be starved for air.

If the fryer's gas and air supplies are okay, the problem most likely is with one of the electrical components. Examine the controller for signs of melting/distortion and/or discoloration due to excessive heat buildup in the fryer. (This condition usually indicates improper flue performance.). A discolored or distorted controller is automatically suspect and should be replaced. However, unless the condition causing excessive heat in the fryer is corrected, the problem is likely to recur.

The ***burner lighting on one side only*** may be caused by a missing or misaligned rear deflector target or improper burner manifold pressure. Clogged burner orifices are usually the cause of ***gaps in burner firing***.

Fluctuating flame intensity is normally caused by either improper or fluctuating incoming gas pressure, but may also be the result of variations in the kitchen atmosphere. Verify incoming gas pressure in the same way as for "popping," discussed in the preceding paragraphs. Variations in the kitchen atmosphere are usually caused by air conditioning and/or ventilation units starting and stopping during the day. As they start and stop, the pressure in the kitchen may change from positive or neutral to negative, or vice versa. They may also cause changes in airflow patterns that may affect flame intensity.

Flames "rolling" out of the fryer are usually an indication of negative pressure in the kitchen. Air is being sucked out of the fryer enclosure and the flames are literally following the air. If negative pressure is not the cause, check for high burner manifold gas pressure in accordance with the procedures in Section 1.3, ***Checking the Burner Manifold Pressure***. An obstructed flue, which prevents the fryer from properly exhausting, may also be the cause.

An ***excessively noisy burner***, especially with ***flames visible above the flue opening***, may indicate that the burner gas pressure is too high, or it may simply be that the gas valve vent tube is blocked. If the gas pressure is correct and the vent tube is unobstructed, the gas valve regulator is probably defective.

Occasionally a burner may apparently be operating correctly; nevertheless, the fryer has a ***slow recovery rate***. (The recovery rate is the length of time required for the fryer to increase the oil temperature from 250°F to 300°F (121°C to 149°C)). The primary causes of this are low burner manifold pressure and/or misaligned or missing deflector targets. If both of these causes are ruled out, the probable cause is a gas valve regulator that is out of adjustment. Refer to ***Checking the Burner Manifold Pressure*** in Section 1.3.

1.9.3 Improper Temperature Control

Temperature control, including the melt cycle, is a function of several interrelated components, each of which must operate correctly. The principle component is the thermostat (in thermostat control units) or the temperature probe (in fryers equipped with other types of controllers). Depending upon the specific configuration of the fryer, other components may include the interface board and the controller.

Improper temperature control problems can be categorized into melt cycle problems and failure to control at setpoint problems.

MELT CYCLE PROBLEMS

In fryers equipped with thermostat controls, the melt cycle is controlled by a mechanical timer. There are three components that may fail: the melt cycle timer itself, the melt cycle timer microswitch, or the control panel melt cycle ON/OFF switch. In all cases, the defective component must be replaced.

In fryers equipped with other types of controllers, the problem may be with the controller itself, the temperature probe, or a malfunctioning heat relay on the interface board.

For problem isolation techniques, refer to the troubleshooting guides **TROUBLESHOOTING THE THERMOSTAT** and **TROUBLESHOOTING THE TEMPERATURE PROBE**.

FAILURE TO CONTROL AT SETPOINT

In fryers equipped with thermostat controls, the problem will be with the thermostat itself. Possible causes are that the thermostat is out of calibration, the knob or flexible shaft is loose on the thermostat shaft, a thermostat wire is disconnected or broken, or the thermostat is defective. Refer to Section 1.7 for instructions on calibrating the thermostat.

In fryers equipped with other types of controls, the problem may be with the temperature probe, the interface board, or the controller. Refer to the troubleshooting guide **TROUBLESHOOTING THE TEMPERATURE PROBE** for problem isolation techniques.

1.9.4 Computer-Related Problems

COMPUTER MAGIC FEATURES

SENSITIVITY OR “*STRETCH AND SHRINK TIME*”

Sensitivity or stretch time is a programmable feature, patented by Frymaster that increases or decreases the cook time countdown based on variations in the oil temperature from the set point.

The sensitivity for each product button has ten settings (0 through 9). A zero sensitivity setting will disable the feature (no change in cooking time), while a nine will provide the highest sensitivity or most change. The correct sensitivity for any product is based on the product, its density, the set point temperature, and the customer’s own requirements.

RECOVERY TIME

Recovery time or rate of rise is a method of measuring a fryer’s performance. Put simply, it is the time required for the fryer to increase the oil temperature from 250°F to 300°F (121°C to 149°C). This range is used as a standard since ambient kitchen temperatures can effect the test if lower ranges are used.

The Computer Magic performs the recovery test each day as the fryer warms up. An operator can view the results of the test any time the fryer is above the 325°F (163°C) point by pressing the button and entering the code 1652. The test results will be displayed in the computer’s LED panel in minutes and seconds. The acceptable recovery time for 45 Series fryers is 2 minutes and 25 seconds.

COMMON COMPUTER COMPLAINTS

Most problems concerning computers have to do with programming them. There are four common complaints. The complaints, their causes, and corrective actions are:

1. Fryer constantly displays “HI.”

Cause: Setpoint incorrect or missing.

Corrective Action: Press 1650, enter the correct setpoint using keypad, then press to lock in the setpoint.

2. Temperature is displayed in Celsius.

Cause: Computer is programmed to display in Celsius.

Corrective Action: Press 1658.

3. Temperature is constantly displayed.

Cause: Computer is programmed for constant temperature display.

Corrective Action: Press 165L.

4. Computer times down too slowly or too quickly.

Cause: Computer is compensating for oil temperature via the sensitivity setting.

Corrective Action: Reprogram sensitivity setting for each product in accordance with programming instructions in Chapter 3 of the 45 Series Gas Fryer Installation and Operation Manual.

1.9.5 Filtration Problems

The majority of filtration problems arise from operator error. One of the most common errors is placing the filter paper on the bottom of the filter pan rather than over the filter screen.

Whenever the complaint is “the pump is running, but no oil is being filtered,” check the installation of the filter paper, including that the correct size is being used. While you are checking the filter paper, verify that the O-rings on the bottom of the filter pan and on the male disconnect (at inside rear of filter cabinet) are present and in good condition. Missing or worn O-rings will allow the pump to suck air and decrease its efficiency.

If the pump motor overheats, its thermal overload will trip and the motor will not start until it is reset. If the pump motor does not start, press the red reset switch located on the end of the motor nearest the operator. If the pump then starts, something caused the motor to overheat. It may be just that several frypots were being filtered one after the other and the pump got hot. Letting the pump cool down for at least a half-hour is all that is required in this case. More often, the pump overheated for one of the following reasons:

- Shortening was solidified in the pan or filter lines.

- The operator attempted to filter oil or shortening that was not heated. Cold oil and shortening are thicker and cause the pump motor to work harder and overheat.

If the motor tries to run but the pump does not, there is a blockage in the pump. Incorrectly sized or installed paper will allow food particles and sediment to pass through the filter pan and into the pump. When sediment enters the pump, the gears can bind up causing the motor to overload, again tripping the thermal overload. Solidified shortening in the pump will also cause it to seize, with the same result.

A pump seized by debris or hard shortening can usually be freed by manually moving the gears with a screwdriver or other instrument.

1. Disconnect power to the filter system.
2. Remove the input plumbing from the pump.
3. Use a screwdriver to manually turn the gears.
 - Turning the pump gears backwards will release a hard particle and allow its removal.
 - Turning the pump gears forward will push softer objects and solid shortening through the pump and allow free movement of the gears.

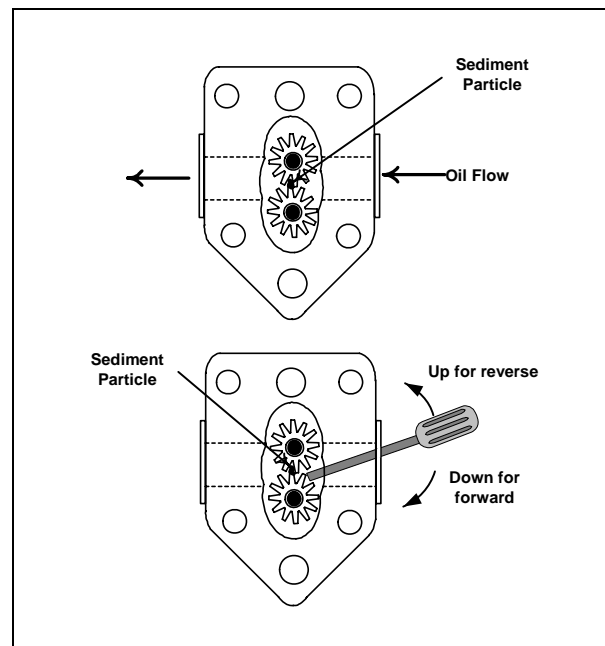

Incorrectly sized or installed paper will also allow food particles and sediment to pass through and clog the suction tube on the bottom of the filter carriage. Particles large enough to block the suction tube may indicate that the crumb tray is not being used.

Pan blockage can also occur if shortening is left in the pan and allowed to solidify. The heater strip on the suction tube is designed to prevent solidification of residual shortening left in the tube. It will not melt or prevent solidification of shortening in the pan.

Blockage removal can be accomplished by forcing the item out with an auger or drain snake. Compressed air or other pressurized gases should not be used to force out the blockage.

Possible problems with the Power Shower include clogged openings, shortening solidified in the tubes, missing clean-out plugs, and missing or worn O-rings. Cleaning the unit and replacing missing plugs and missing or worn O-rings will correct these problems.

The electronics of the Filter Magic II are simple and straightforward. Microswitches, attached to the drain valve handles of each vat and wired in parallel, provide the 24 VAC needed to activate the pump relay coil when the handles are moved to the ON position. The activated coil pulls in the pump motor switch, supplying power to the motor.

The suction tube heater and flexible hose heater are wired directly into the 24VAC source. They remain energized as long as the unit is plugged in.

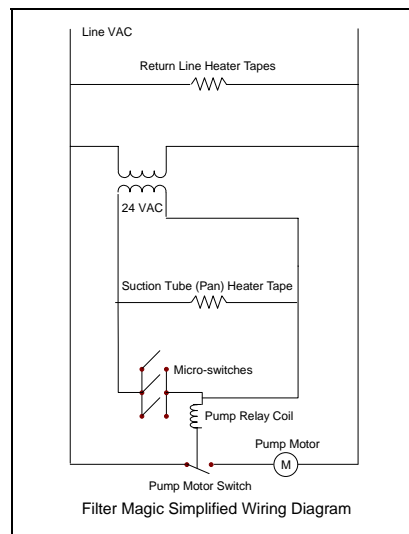

1.9.6 Leakage Problems

Leakage of the frypot almost always will be due to improperly sealed high limit switches, thermostats/temperature probes, and drain fittings. When installed or replaced, each of these components must be sealed with Loctite PST56765 sealant or equivalent to prevent leakage. In very rare cases, a leak may develop along one of the welded edges of the frypot. When this occurs, the frypot must be replaced.

If the sides and/or ends of the frypot are coated with oil/shortening, the most likely cause is spillage over the top of the frypot rather than leakage.

The clamps, which hold the drain tube sections together, may loosen over time as the tubes expand and contract with heating and cooling during use. If the section of drain tube connected to the drain valve is removed for whatever reason, make sure that its grommet is in good condition and properly fitted around the nipple of the drain when it is reinstalled. Also, check to insure that the drain tube runs downward from the drain along its whole length and has no low points where oil or shortening may accumulate.

1.9.7 Basket Lift Malfunctions

45 Series fryers may optionally be equipped with automatic basket lifts to ensure uniform cooking times. The lifts may be configured for manual control or for control via a Basket Lift Timer or Computer Magic computer. Basket lifts will always come in pairs, although each operates independently.

In units configured for manual (push-button) controls, a mechanical or electrical timer controls voltage to the system. A rotary knob is turned to set the cook time, and pressing the button in the middle of the knob activates the motor.

In units with Computer Magic or Basket Lift Timers, timing circuitry in the controller initiates and stops basket lift operation depending upon the variables programmed by the operator. When the

product button is pressed, the timing circuitry activates a coil in the basket lift relay to supply power to the motor.

There are two types of basket lifts: the “bell crank” design, and the “modular” design

A **bell crank** basket lift consists of a cam and bell crank that are connected to the basket lift arm by a flat metal link. The cam is attached to a drive motor. The motor rotates the cam, thus raising or lowering the lift arm linked to the bell crank. A roller-activated microswitch is used to limit travel. When the push-button in the manual timer or the product button for computers is pushed, the motor circuit is completed and the motor runs, lowering the basket. When the roller in the microswitch makes or loses contact with the cam, the switch is reversed and power to the motor is cut. At the end of the specified cooking time, the timer/controller reverses its switch position so that the motor circuit is again complete. The motor runs, raising the basket, until contact with the cam is again made or lost.

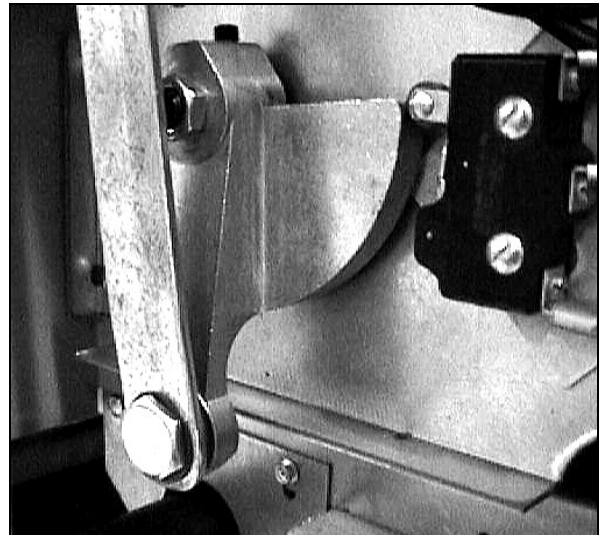

Left bell crank and cam with basket lift link shown in the down position. Note the microswitch in the upper right corner.

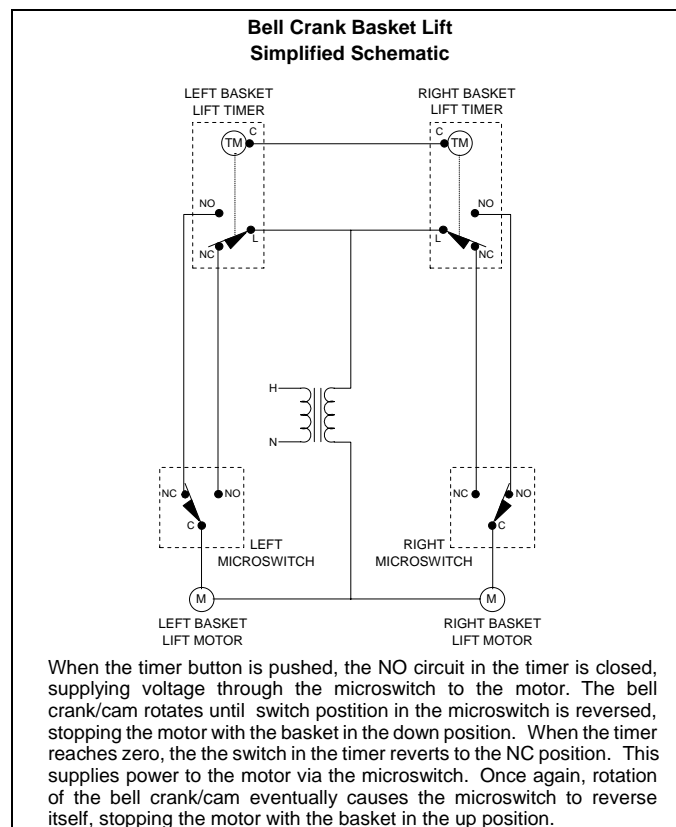

A **modular basket lift** consists of a toothed rod to which the basket lift arm is attached, a reversible-drive gear motor, and a pair of roller activated microswitches. The gear motor engages the teeth in the rod, moving it up or down depending upon the direction of rotation of the motor. Microswitches at the upper and lower limits of movement stop the motor when the basket is in the full up or full down position and also reverse the direction of current flow thus reversing the motor direction. When the manually set or programmed cooking time has elapsed, current is again supplied to the basket lift and the basket is raised.

When the timer times-out, power is supplied to the opposite pole of the motor through the upper microswitch. The motor drives the rod upward until it loses contact with the upper microswitch, cutting power to the motor and stopping the lift.

In units configured for Basket Lift Timer Controllers or Computer Magic computers, the process is almost identical. The difference is that the push button mechanical timer is replaced with timing circuitry in the computer or controller. The specific cook times (and other settings) are programmed into the computer or controller by the operator. When the product button is pressed, the timing circuitry activates a coil in the basket lift relay to supply power to the lower microswitch. As with the manually controlled units, the microswitches stop the motor at the lift's upper and lower travel limits and reverse the direction of current flow thus reversing the motor direction.

Problems with the basket lift system can be grouped into three categories:

- Binding/jamming problems
- Motor and gear problems
- Electronics problems

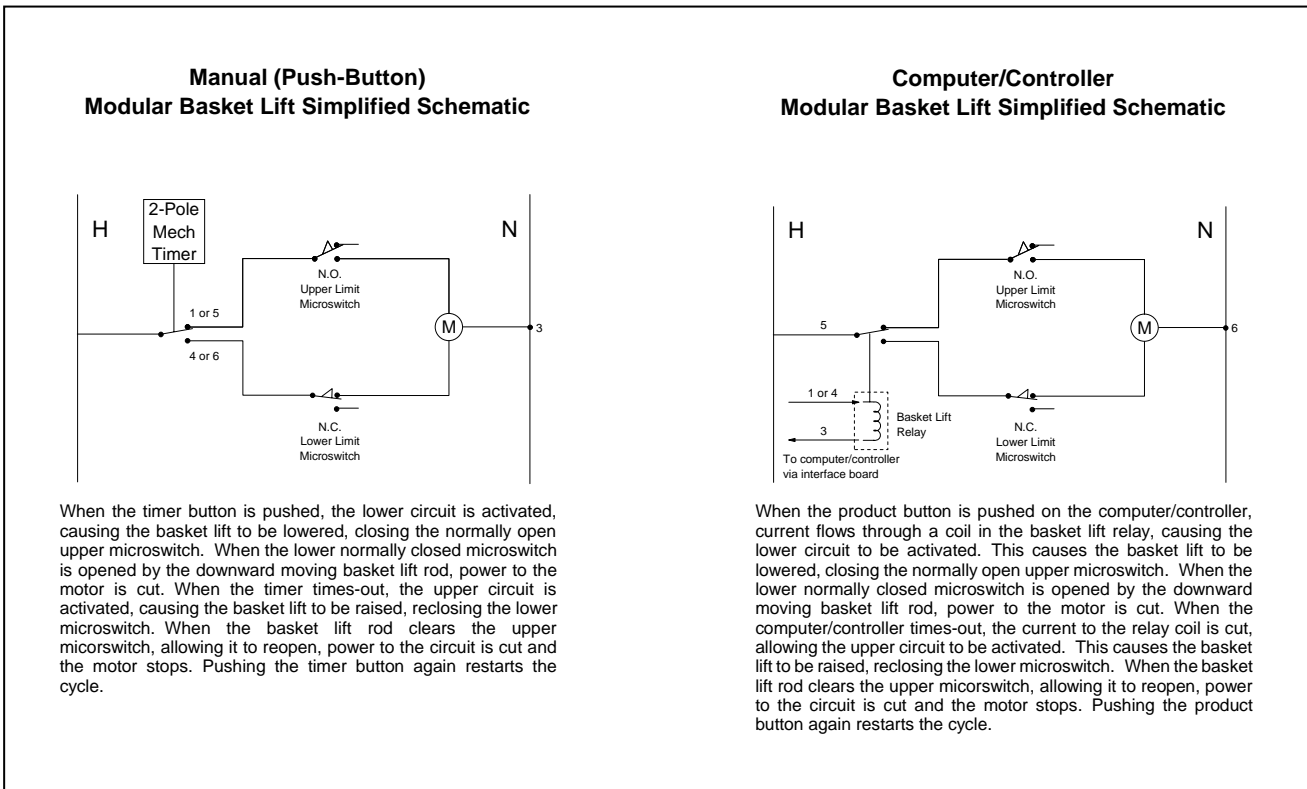

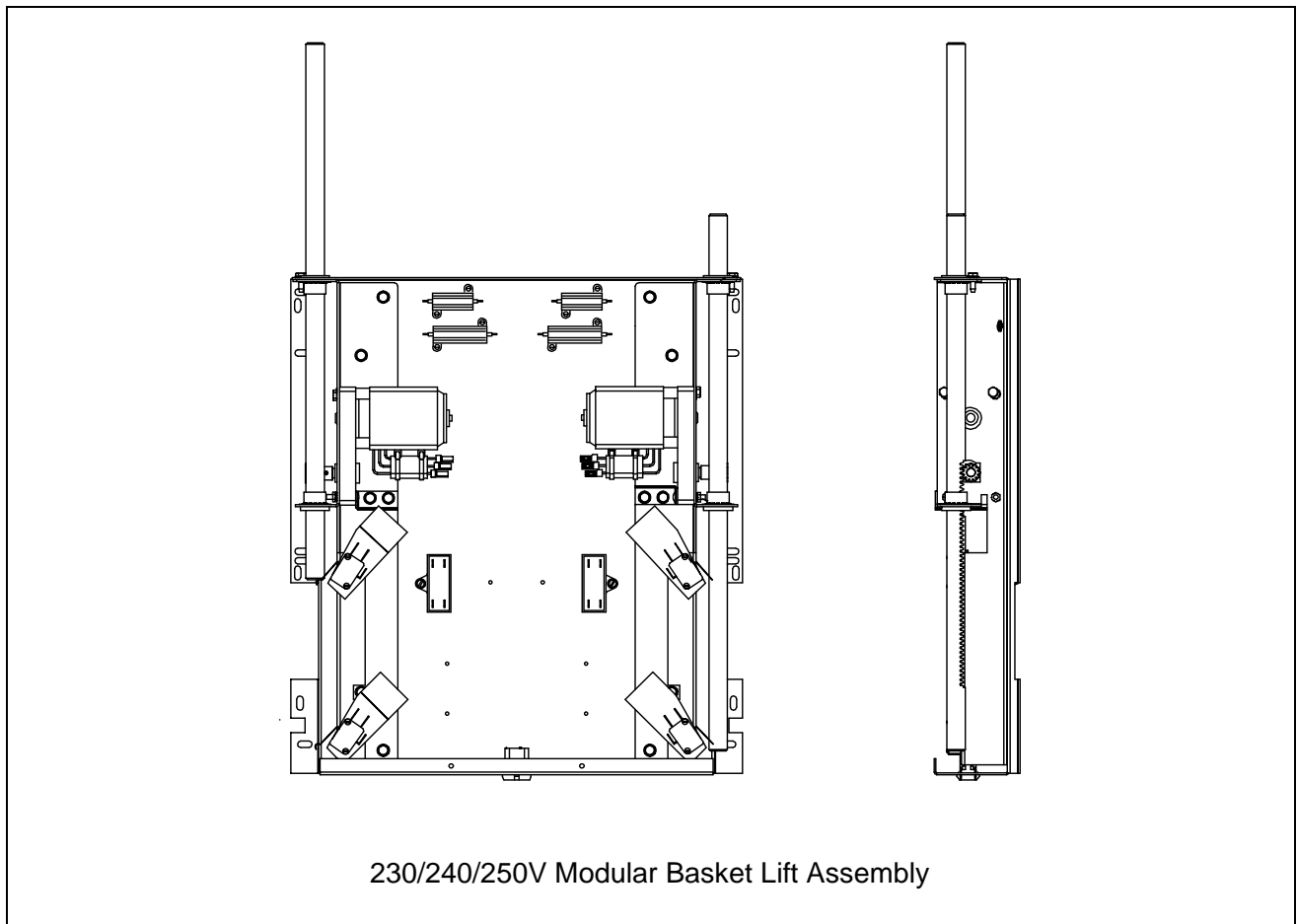

BINDING/JAMMING PROBLEMS

Noisy, jerky or erratic movement of the lifts is usually due to lack of lubrication of the rods and their bushings. Apply a light coat of Lubriplate™ or similar lightweight white grease to the rod and bushings to correct the problem.

Another possible cause of binding, in the case of modular basket lifts, is the improper positioning of the motor, which prevents the gear from correctly engaging the teeth in the rod. To correct the problem, loosen the screws that hold the motor in place and move it forward or backward until the rod has just enough slack to be rotated slightly.

MOTOR AND GEAR PROBLEMS

In modular basket lift units, the most likely problem to be encountered in this category is erratic motion of the lift due to a worn drive gear. Failure to keep the lift rod and bushings properly lubricated will cause unnecessary wear of the gear. The problem is corrected by replacing the worn gear.

If the lift cycles correctly but fails to remain in the up position (i.e., goes up, but then slowly settles back down into the frypot), the problem is a failed motor brake. A failed motor brake cannot be repaired and requires replacement of the motor itself.

If power is reaching the motor but the motor fails to run, the motor is burned out and must be replaced.

ELECTRONICS PROBLEMS

This category encompasses problems with the relays, microswitches, capacitors, resistors, interface board, wiring, and controls. Troubleshooting the electronics of both bell crank and modular basket lifts is simply a process of verifying current flow through the individual components up to and including the motor. Using a multimeter set to the 250 VAC range, check the connections on both sides of the component for the presence of 120 VAC.

The simplified wiring diagrams that follow identify the components and wiring connection points.

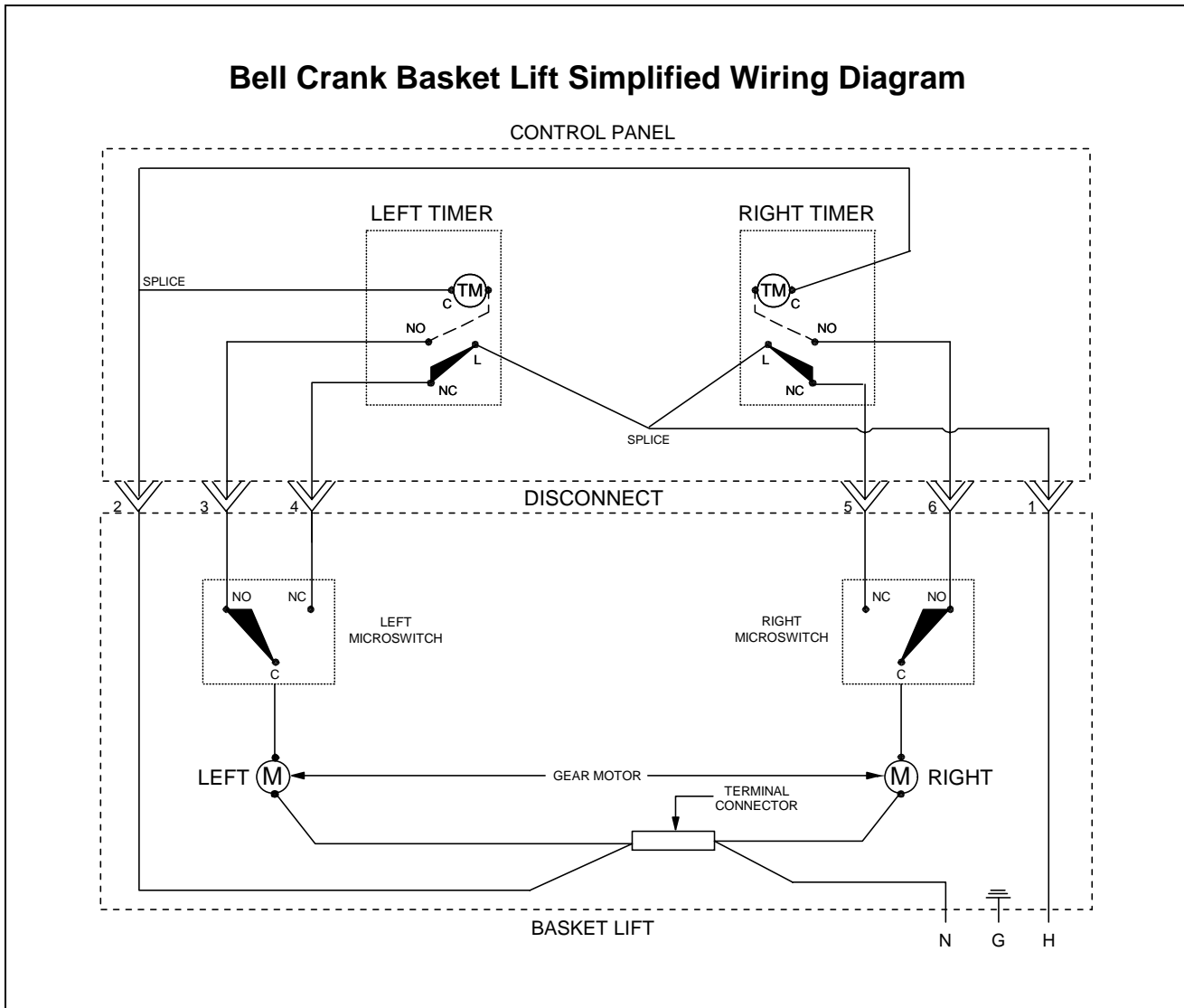

Modular Basket Lift Simplified Wiring Diagram

NOTE: References to right and left are from the rear of the fryer.

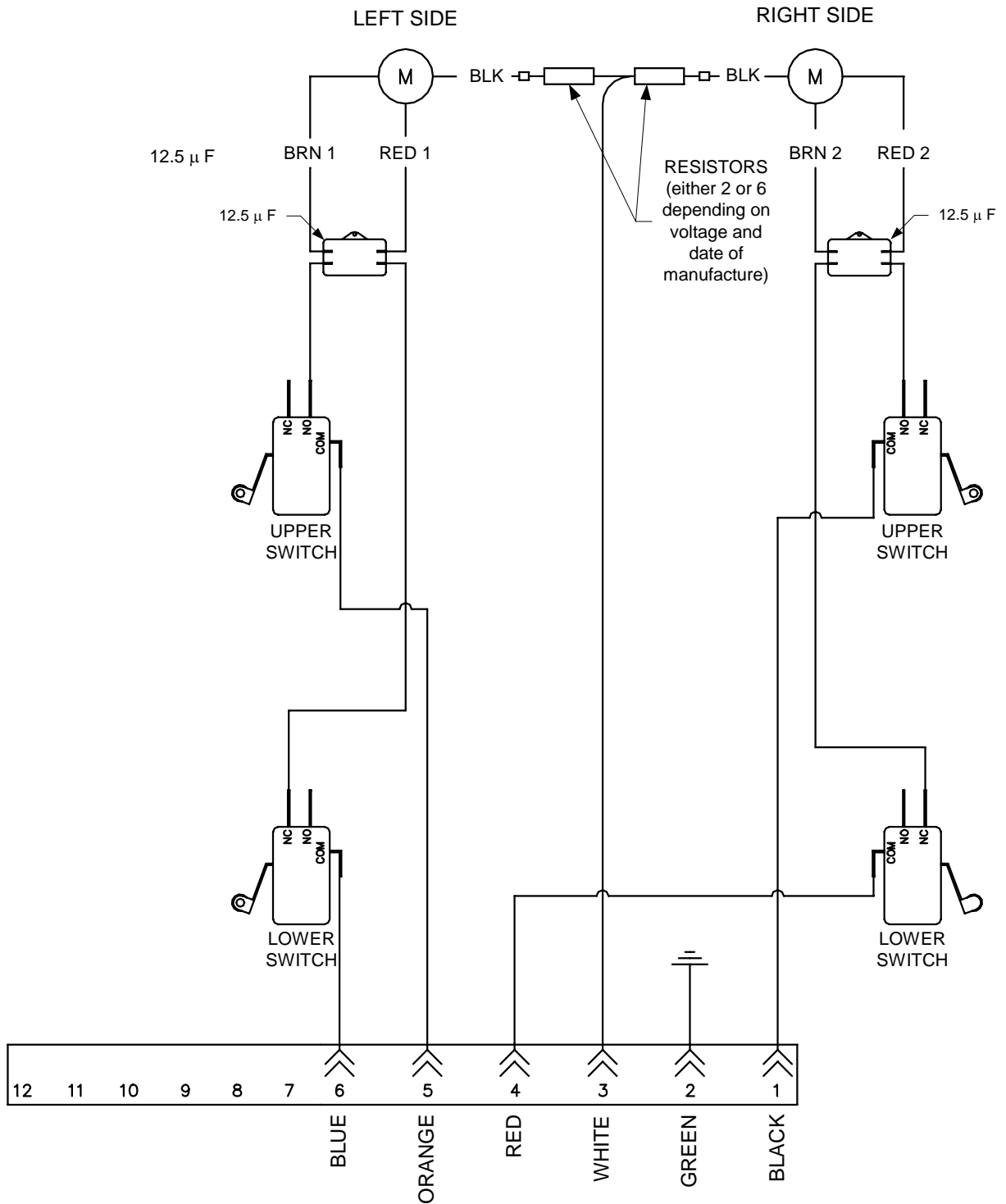

1.9.8 Interpretation of Digital Controller Lights

Power light on, heat light cycling, trouble light off, and melt light on:

- If fryer oil temperature is below 180°F (82°C), the lights indicate the unit is operating normally.
- If the oil temperature is above 180°F (82°C) and the heat light continues to cycle as if in the melt cycle, this may indicate a defective probe circuit or low incoming 12VAC to the controller.

Power light on, heat light on, trouble light off, and melt light off:

- If the fryer oil temperature is above 180°F (82°C) and below the setpoint temperature, the lights indicate the unit is operating properly.
- If the oil temperature is above the temperature set on the control knob and the heat light remains lit, this may indicate a defective probe circuit.

Power light on, heat light off, trouble light on, and melt light off:

- If the fryer oil temperature is below 410°F (210°C), the lights indicate one of the following:
 - a. The probe circuit is defective, or
 - b. There is a connection problem on pins 2 or 10 on the 15-pin wiring harness.
- If the fryer oil temperature is above 410°F (210°C), the lights indicate a run-away heating circuit.

1.10 Troubleshooting Guides

The troubleshooting guides found in the pages that follow are intended to assist service technicians in quickly isolating the probable causes of equipment malfunctions by following a logical, step-by-step process.

1.10.1 Troubleshooting the 24VAC Circuit in Units without Interface Boards

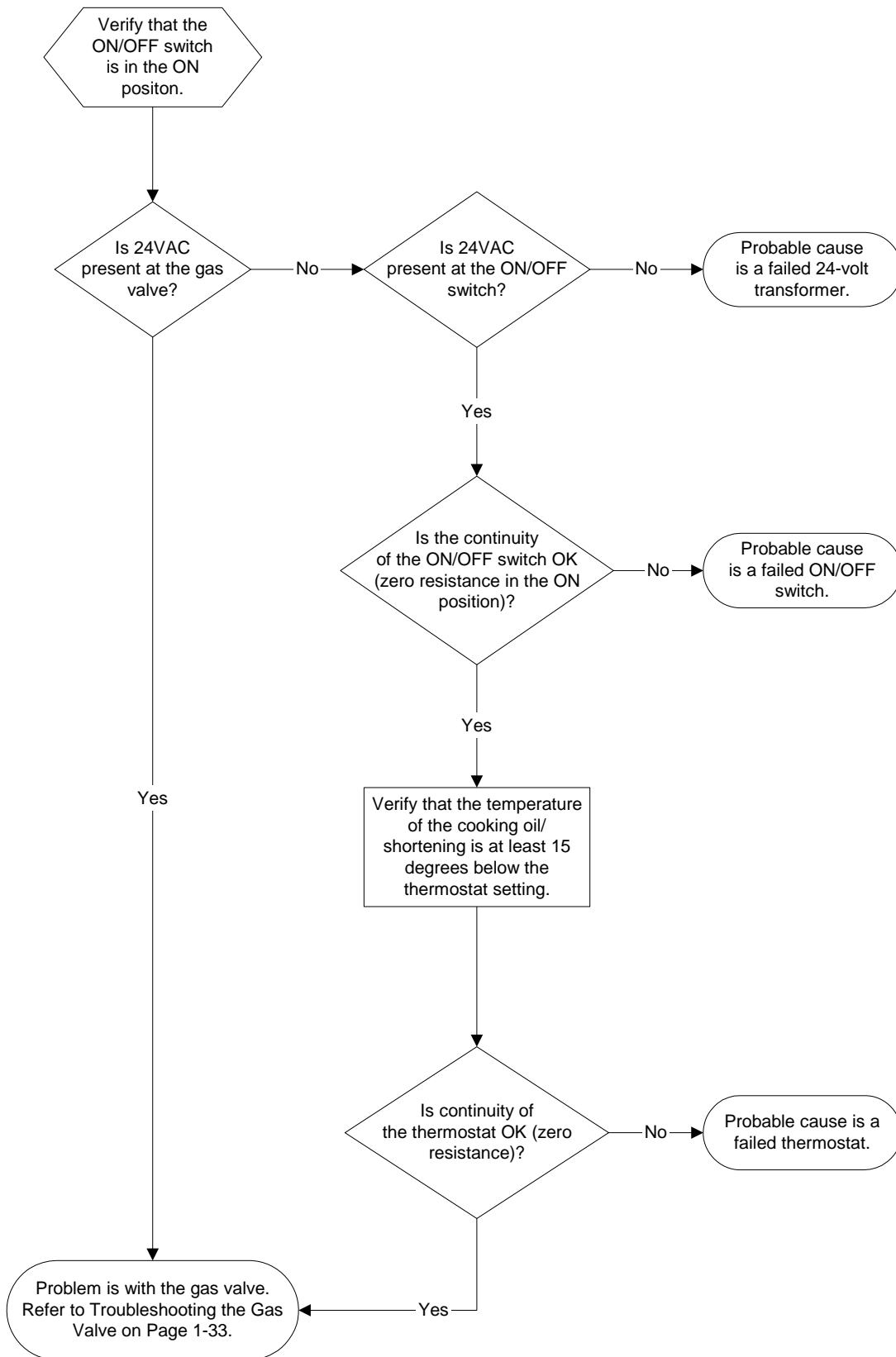

1.10.2 Troubleshooting the 24 VAC Circuit in Units with Interface Boards

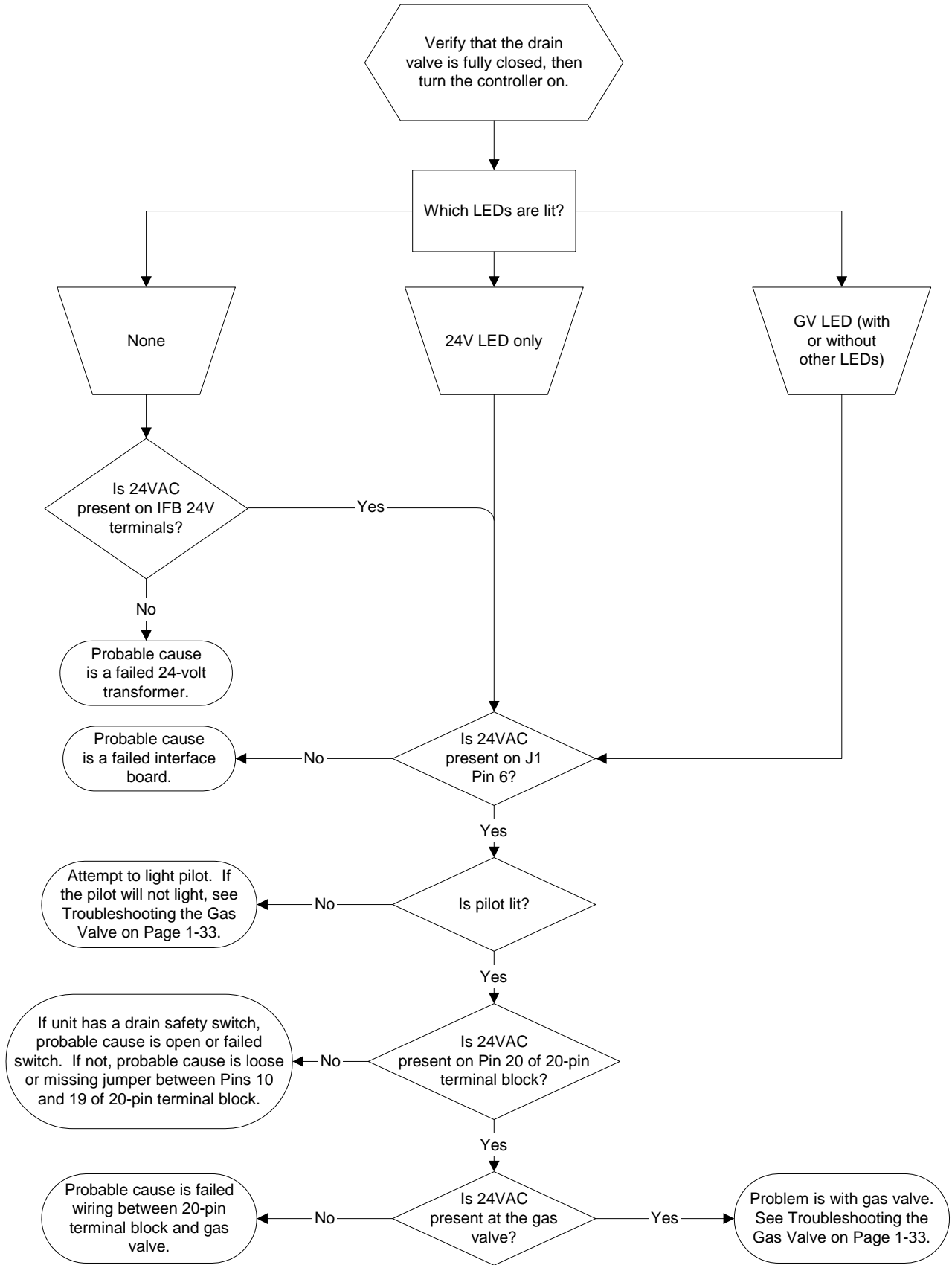

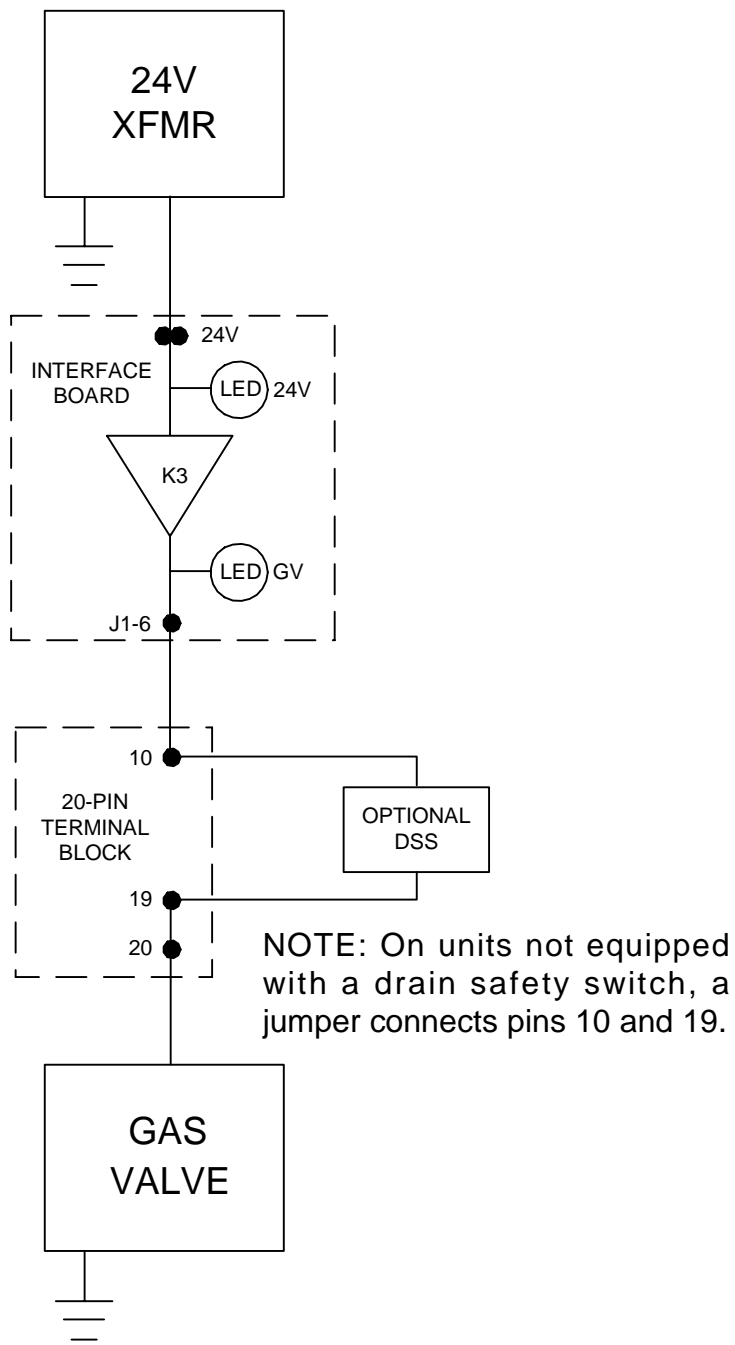

24 VOLT CIRCUIT
ON UNITS WITH INTERFACE BOARDS

1.10.3 Troubleshooting the Gas Valve

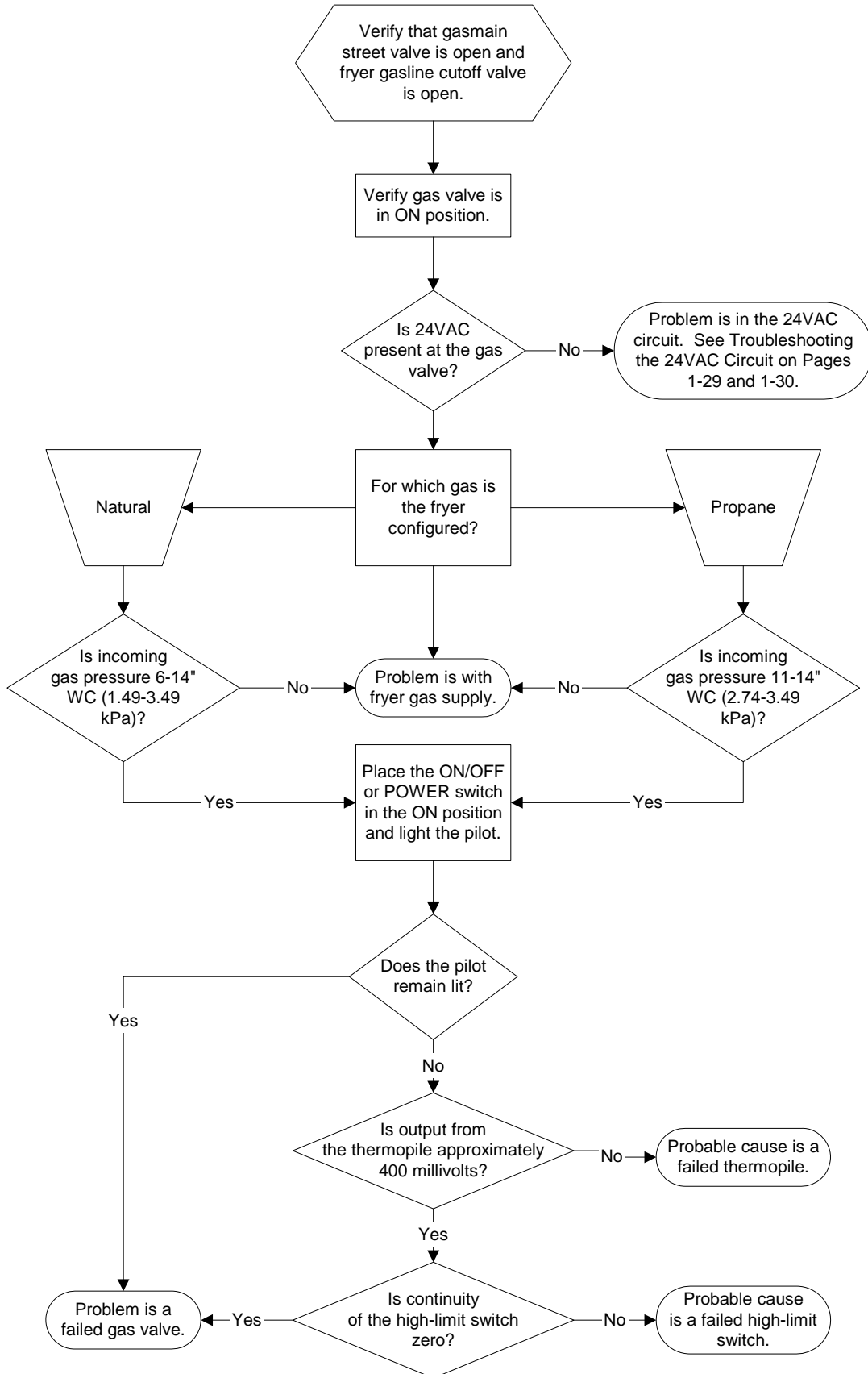

1.10.4 Troubleshooting the Thermostat

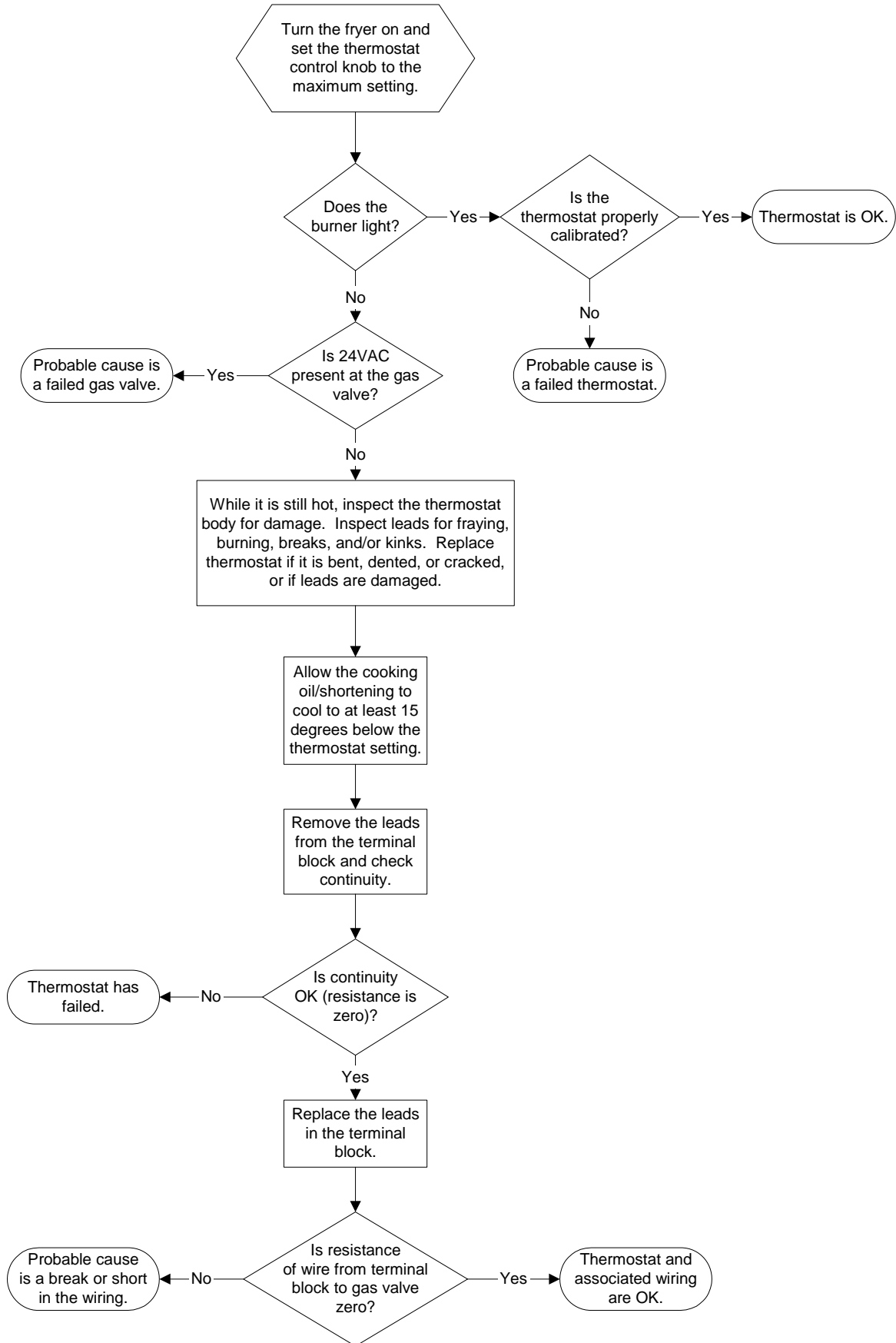

1.10.5 Troubleshooting the Temperature Probe

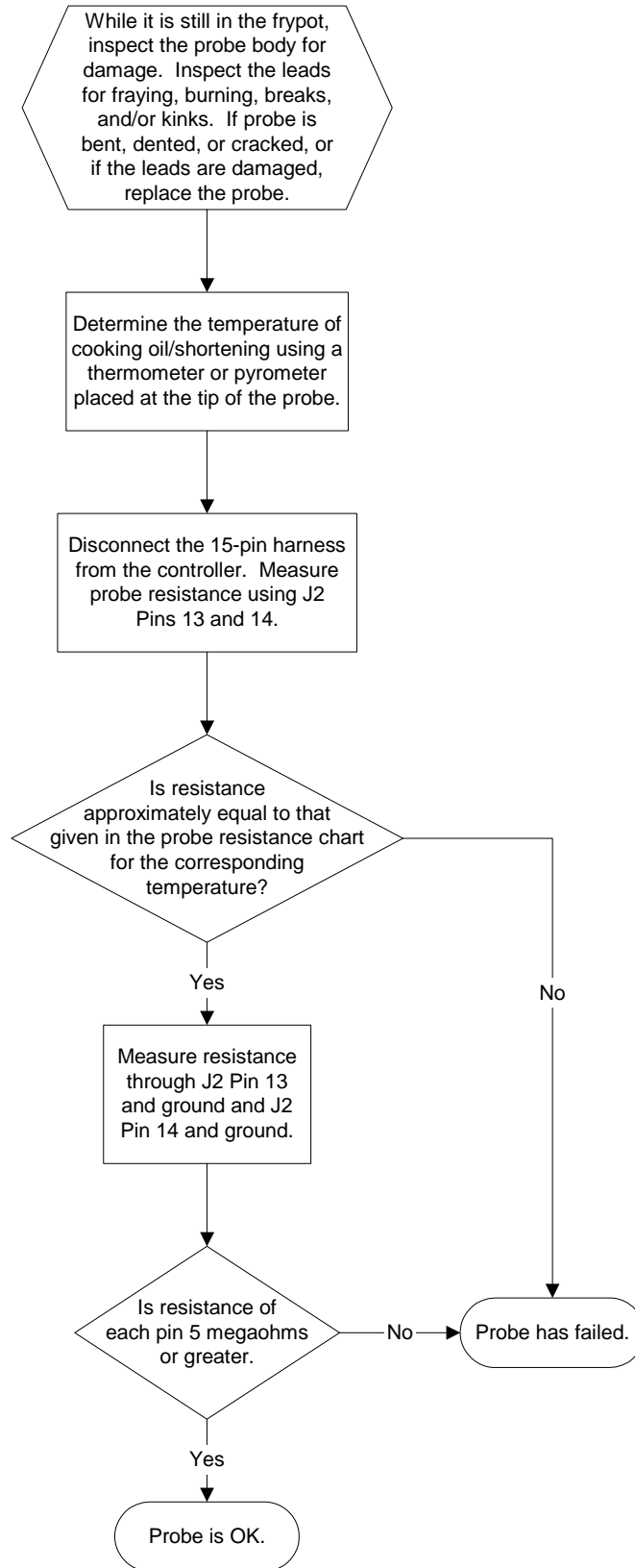

Probe Resistance Chart

For use with 45 Series fryers manufactured with Minco Thermistor probes only.

| F | OHMS | C | F | OHMS | C | F | OHMS | C | F | OHMS | C | F | OHMS | C |
|-----|------|----|-----|------|----|-----|------|-----|-----|------|-----|-----|------|-----|
| 60 | 1061 | 16 | 130 | 1206 | 54 | 200 | 1350 | 93 | 270 | 1493 | 132 | 340 | 1634 | 171 |
| 65 | 1070 | 18 | 135 | 1216 | 57 | 205 | 1361 | 96 | 275 | 1503 | 135 | 345 | 1644 | 174 |
| 70 | 1080 | 21 | 140 | 1226 | 60 | 210 | 1371 | 99 | 280 | 1514 | 138 | 350 | 1654 | 177 |
| 75 | 1091 | 24 | 145 | 1237 | 63 | 215 | 1381 | 102 | 285 | 1524 | 141 | 355 | 1664 | 179 |
| 80 | 1101 | 27 | 150 | 1247 | 66 | 220 | 1391 | 104 | 290 | 1534 | 143 | 360 | 1674 | 182 |
| 85 | 1112 | 29 | 155 | 1258 | 68 | 225 | 1402 | 107 | 295 | 1544 | 146 | 365 | 1684 | 185 |
| 90 | 1122 | 32 | 160 | 1268 | 71 | 230 | 1412 | 110 | 300 | 1554 | 149 | 370 | 1694 | 188 |
| 95 | 1133 | 35 | 165 | 1278 | 74 | 235 | 1422 | 113 | 305 | 1564 | 152 | 375 | 1704 | 191 |
| 100 | 1143 | 38 | 170 | 1289 | 77 | 240 | 1432 | 116 | 310 | 1574 | 154 | 380 | 1714 | 193 |
| 105 | 1154 | 41 | 175 | 1299 | 79 | 245 | 1442 | 118 | 315 | 1584 | 157 | 385 | 1724 | 196 |
| 110 | 1164 | 43 | 180 | 1309 | 82 | 250 | 1453 | 121 | 320 | 1594 | 160 | 390 | 1734 | 199 |
| 115 | 1174 | 46 | 185 | 1320 | 85 | 255 | 1463 | 124 | 325 | 1604 | 163 | 395 | 1744 | 202 |
| 120 | 1185 | 49 | 190 | 1330 | 88 | 260 | 1473 | 127 | 330 | 1614 | 166 | 400 | 1754 | 204 |
| 125 | 1195 | 52 | 195 | 1340 | 91 | 265 | 1483 | 129 | 335 | 1624 | 168 | 405 | 1764 | 207 |

PLAN WIRING DIAGRAM CE FM/MJ 45 W/O COMPUTER

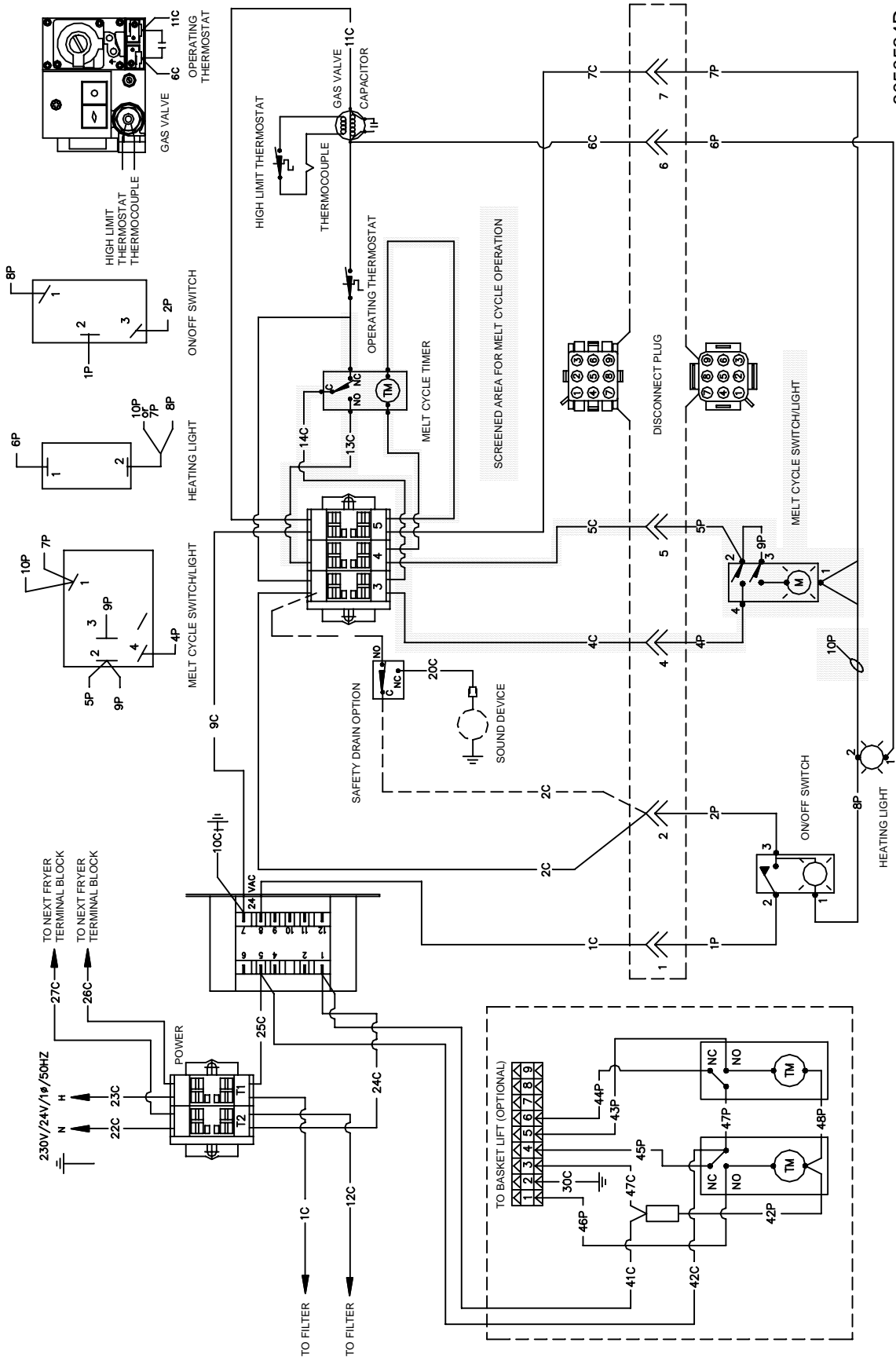

8050534D

PLAN WIRING DIAGRAM FOR FILTER MAGIC II
(DIRECT)

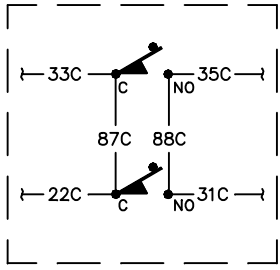
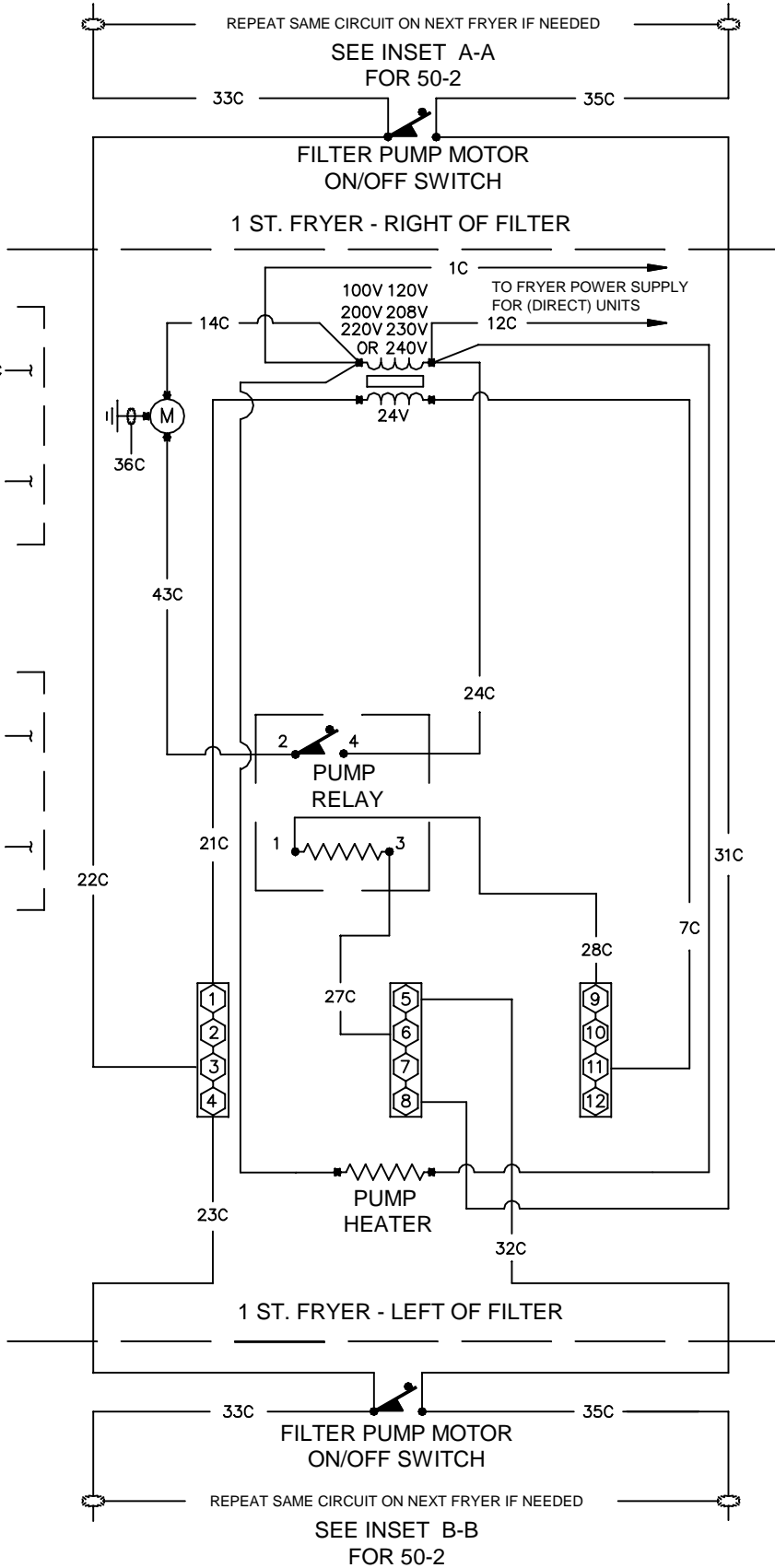

INSET A-A

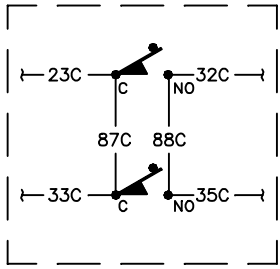

INSET B-B

8050385D

PLAN WIRING DIAGRAM 45 SERIES BASKET LIFT SYSTEM

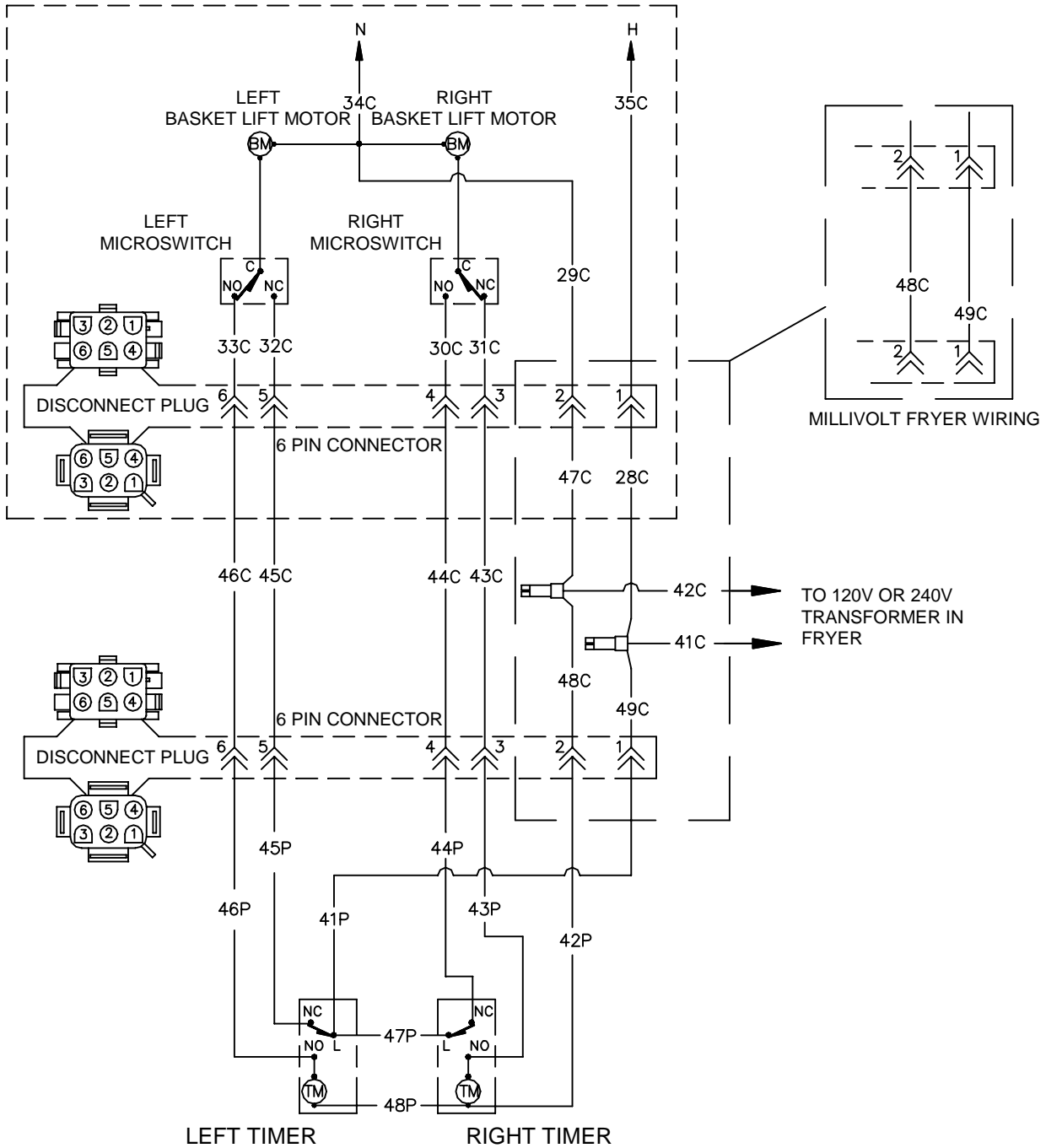

8050379E

PLAN WIRING DIAGRAM 45 SERIES BASKET LIFT SYSTEM

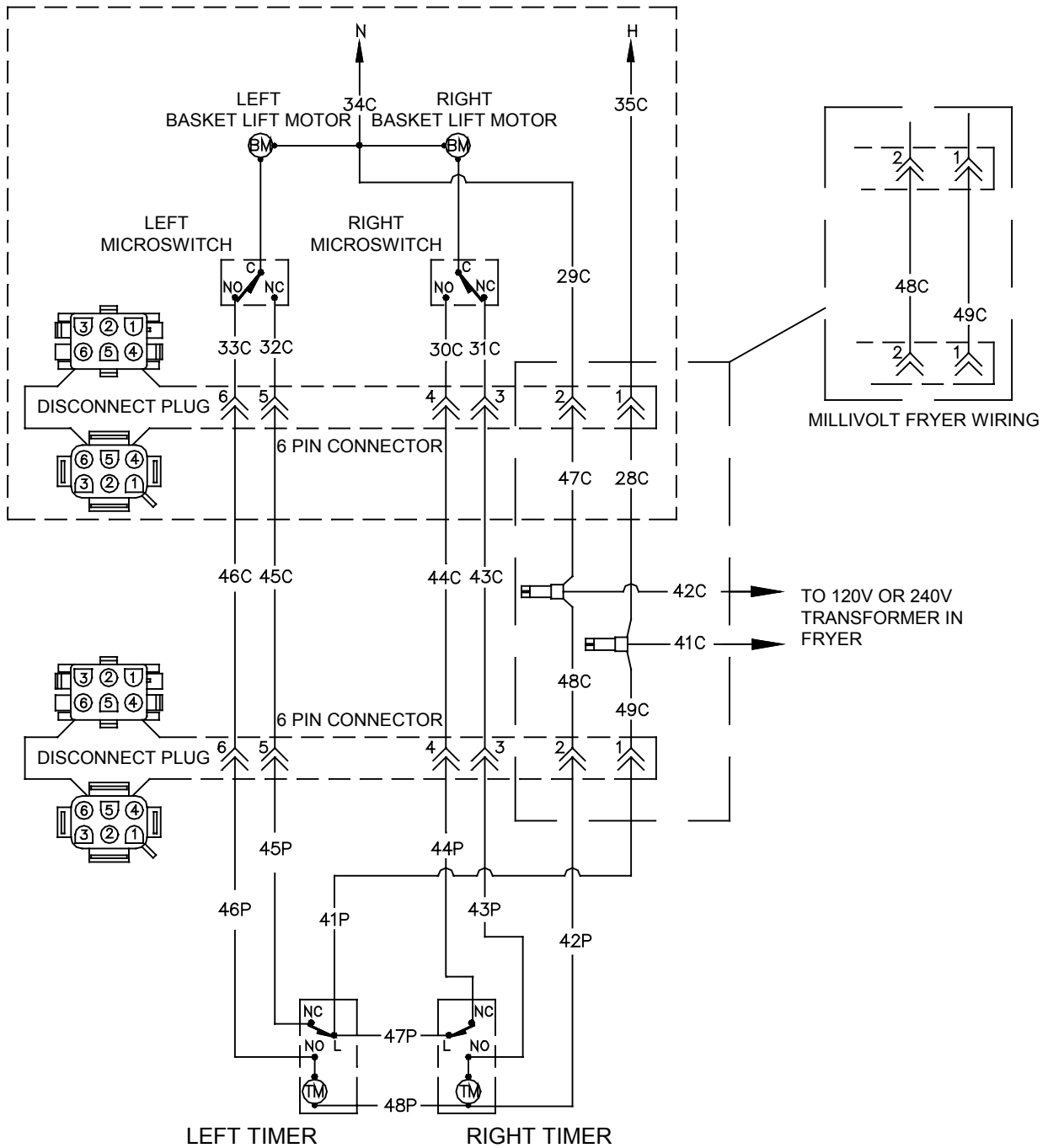

8050379E

THIS PAGE INTENTIONALLY LEFT BLANK.

45 SERIES GAS FRYERS SERVICE AND PARTS MANUAL

CHAPTER 2: PARTS LIST

ACCESSORIES

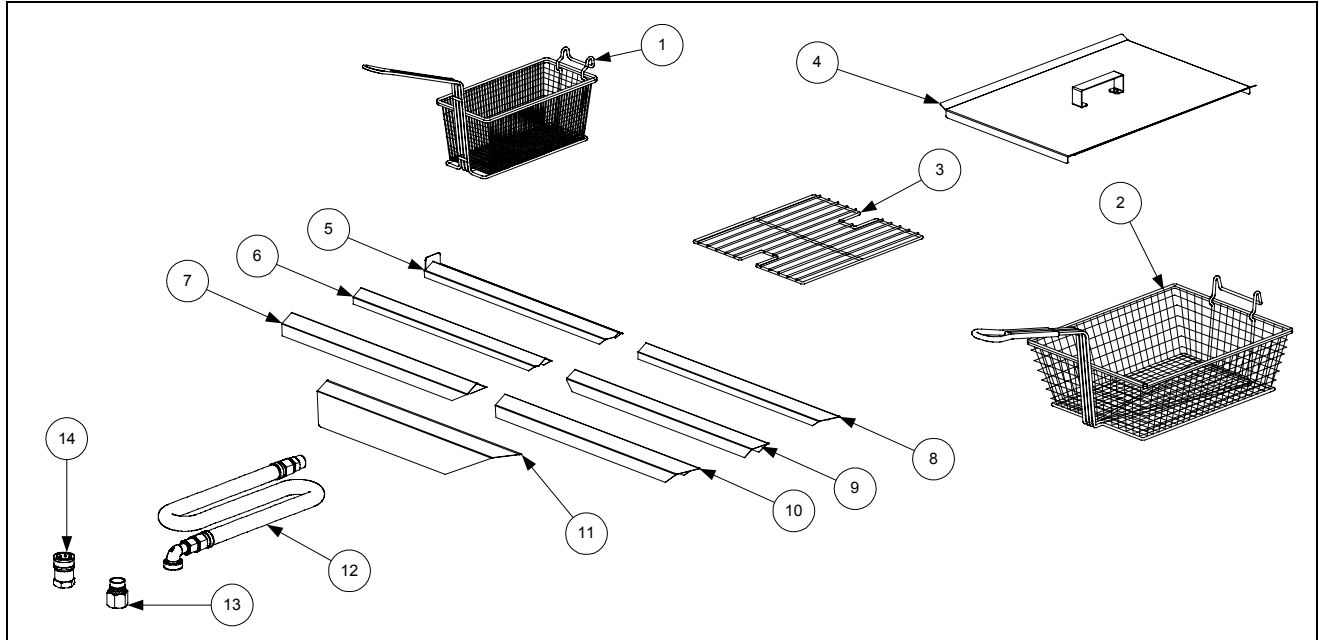

| ITEM | PART # | COMPONENT |
|------|----------------------------|--|
| 1 | 803-0271 | Basket, Twin |
| 2 | 803-0099 | Basket, Full (cannot be used with basket lifts) |
| 3 | 803-0132 | Basket Support Rack |
| * | 803-0136 | Basket Support Screen (screen w/handle used in place of Item 3) |
| * | 803-0103 | Sediment Tray |
| 4 | 806-5518 | Cover, Frypot or Holding Station |
| * | 826-0993SP | Handle Kit, Frypot Cover (includes handle and screws) |
| 5 | 823-1885 | Connecting Strip w/back plate (Burger King only) |
| 6 | 910-4617 | Connecting Strip (blunt point, 1/2" sides, 20.70" long) |
| 7 | 910-2285 | Connecting Strip (blunt point, 1" sides, 20.80" long) |
| 8 | 910-7515 | Connecting Strip (sharp point, 1/2" sides, 21.73" long) |
| 9 | 910-7443 | Connecting Strip (sharp point, 1" sides, 21.73" long) |
| 10 | 910-7515SP | Connecting Strip (sharp point, 1" sides, 21.84" long) |
| 11 | 910-2572 | Connecting Strip (sharp point, 3" sides, 21.84" long) |
| 12 | | Gas Line, 1-Inch Dormont Flexible (includes Items 13 and 14) |
| | 806-1698SP | 36-Inch (for gas line only (w/o Items 13 and 14), use 810-0088) |
| | 806-1699 | 42-Inch (for gas line only (w/o Items 13 and 14), use 810-0085) |
| 13 | 810-0074 | Quick-Disconnect Fitting, 1-Inch Male |
| 14 | 810-0073 | Quick-Disconnect Fitting, 1-Inch Female |

* Not illustrated.

BASKET LIFT ASSEMBLIES AND COMPONENT PARTS

Bell Crank Basket Lift

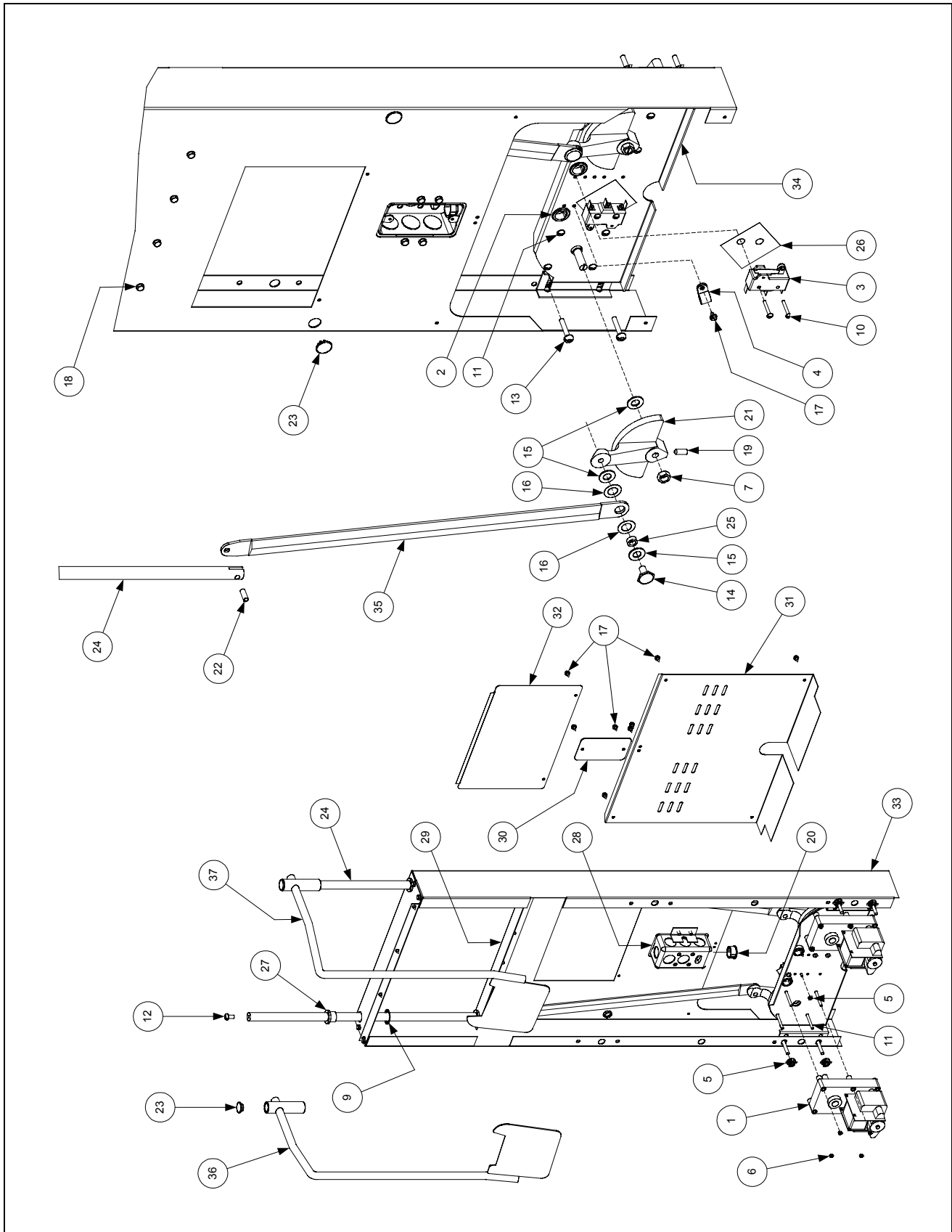

| ITEM | PART # | COMPONENT |
|------|---------------------------|--|
| 1 | | Gear Motor, Basket Lift |
| | 807-0107 | 120VAC |
| | 807-0108 | 240VAC |
| 2 | 807-0124 | Bushing, Plastic |
| 3 | 807-0240 | Microswitch |
| 4 | 826-1680 | Clamp, Plastic Wire (Pkg. of 8) |
| 5 | 826-1358 | Nut, 6-32 Hex (Pkg. of 25) |
| 6 | 809-0050 | Nut, 2-32 Hex |
| 7 | 809-0063 | Nut, Jam 3/8-16 Hex |
| 8 | 809-0076 | Nut, 1/4-20 x 3/4 Expansion |
| 9 | 809-0082 | Ring, Truarc Retaining |
| 10 | 809-0097 | Screw, 6-32 X 1-inch Slotted Truss Head |
| 11 | 809-0113 | Screw, 2-32 X 1 1/2-inch Slotted Truss Head |
| 12 | 809-0127 | Screw, 1/4-20 X 1/2-inch Slotted Round Head |
| 13 | 826-1370 | Screw, 1/4-20 X 1 1/4-inch Slotted Round Head (Pkg. of 10) |
| 14 | 809-0155 | Leveling Screw |
| 15 | 809-0196 | Washer, 3/8-inch Steel Flat |
| 16 | 826-1381 | Washer, Nylon (Package of 10 each 809-0203) |
| 17 | 809-0360 | Screw, 2-32 X 3/8-inch Slotted Hex Washer Head |
| 18 | 826-1374 | Screw, 10 X 1/2-inch Hex Washer Head (Pkg. of 25) |
| 19 | 809-0480 | Setscrew, 1/4-28 X 5/8-inch Hex Socket Head |
| 20 | 810-0045 | Bushing, Plastic |
| 21 | 810-0052 | Bellcrank and Cam |
| 22 | 810-0170 | Pin, Connecting |
| 23 | 810-0172 | Plug, 5/8-inch Hole S/S |
| 24 | 810-0192 | Rod, Basket Lift |
| 25 | 810-0220 | Spacer, Tubular |
| 26 | 812-0138 | Insulation, Paper (Fishpaper) |
| 27 | 813-0035 | Bushing, Bronze |
| 28 | 823-1419 | Box, Electrical Wiring |
| 29 | 900-4110 | Angle, Bearing Support |
| 30 | 910-0119 | Cover, Electrical Wiring Box |
| 31 | 910-3177 | Panel, Stainless Steel Rear Access (for mild steel, use 900-3177) |
| 32 | 910-3783 | Cover, Stainless Steel Rear Cabinet (for mild steel, use 900-3783) |
| 33 | 910-9361 | Housing, Basket Lift Stainless Steel (for mild steel, use 900-9361) |
| 34 | 920-3233 | Plate, Basket Lift Motor Mounting |
| 35 | 920-6076 | Link, Basket Lift |
| 36 | 823-06931 | Basket Lift Arm, Left |
| 37 | 823-06932 | Basket Lift Arm, Right |

NOTE: See Page 2-20 for Roller Bracket Assembly.

Modular Basket Lift

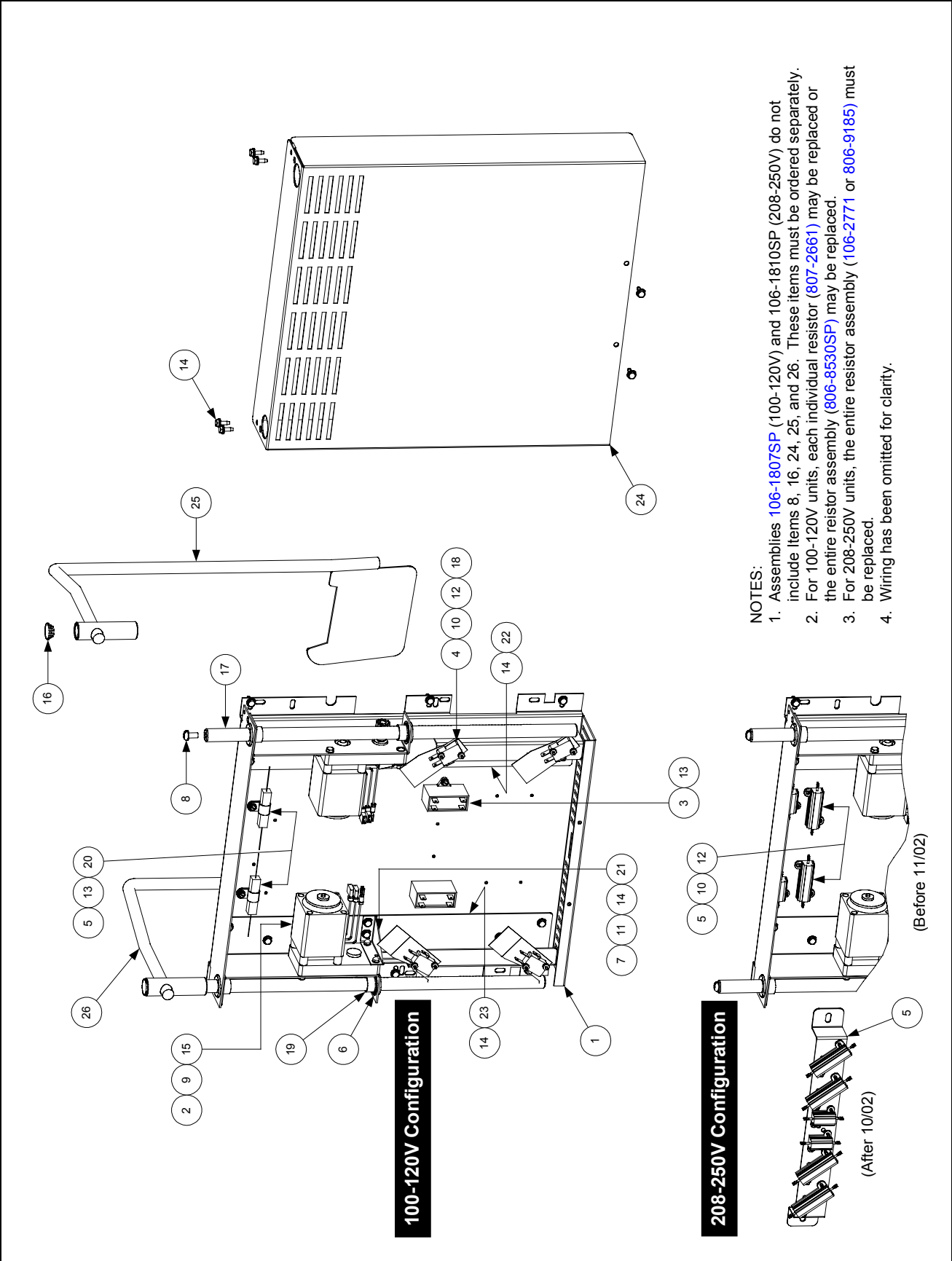

| ITEM | PART # | COMPONENT |
|------|------------|--|
| 1 | | Mount, Modular Basket Lift** |
| | 200-2942 | For use on units with 12-pin connectors |
| | 900-7655 | For use on units with 6-pin connectors |
| 2 | 806-5964SP | Motor Assembly, Modular Basket Lift*** |
| 3 | 807-2133 | Capacitor, 12.5 μ Farad, 250VAC Motor Run |
| 4 | 807-2572 | Microswitch |
| 5 | | Resistor Assembly |
| | 806-8530SP | 100-120V Modular Basket Lift (see Note 2 in illustration) |
| | 106-2771 | 208-250V Modular Basket Lift (before 11/02 use 806-9185; see illust. Note 3) |
| 6 | 809-0082 | Ring, Truarc Retaining |
| 7 | 826-1361 | Screw, 2-32 X 1-inch Slotted Truss Head (Pkg. of 25) |
| 8 | 809-0127 | Screw, ¼-20 X ½-inch Slotted Round Head |
| 9 | 809-0186 | Lock Washer w/External Teeth, #8 |
| 10 | 826-1366 | Nut, 4-40 Hex Keps (Pkg. of 25) |
| 11 | 809-0247 | Nut, 2-32 Hex Keps |
| 12 | 826-1359 | Screw, 4-40 X ¾-inch Slotted Round Head (Pkg. of 25) |
| 13 | 826-1371 | Screw, #8 X ½-inch Hex Head Drill Point (Pkg. of 25) |
| 14 | 826-1374 | Screw, #10 X ½-inch Hex Head (Pkg. of 25) |
| 15 | 809-0503 | Screw, 2-32 X ½-inch Hex Head |
| 16 | 810-0172 | Plug, ⅝-inch Stainless Steel Hole |
| 17 | 810-1012 | Rod, Modular Basket Lift |
| 18 | 812-0442 | Insulation, Microswitch |
| 19 | 813-0035 | Bushing, Bronze, .640" ID |
| 20 | 816-0033 | Tie Wrap, Screw Mount |
| 21 | 900-5529 | Gusset, Modular Basket Lift Motor |
| 22 | 901-8499 | Chassis, Modular Basket Lift, Left |
| 23 | 902-8499 | Chassis, Modular Basket Lift, Right |
| 24 | 910-4776 | Cover, S/S Modular Basket Lift (for CRS cover use 900-4776) |
| 25 | 823-06931 | Arm, Left Basket Lift |
| 26 | 823-06932 | Arm, Right Basket Lift |
| | | Basket Lift Assemblies (see Note 1 in illustration) |
| * | 106-1807SP | 100-120V w/o Relay |
| * | 106-1810SP | 208-250V w/o Relay |

* Not illustrated.

** Basket lift assemblies manufactured prior to February 2002 have 6-pin connectors; those manufactured February 2002 and later have 12-pin connectors. Verify the connector in use before ordering wiring assemblies or mounts.

*** To replace stripped drive gear only, order 810-1013 (gear), 810-0973 (Woodruff key) and 809-0504 (setscrew).

NOTE: See Page 2-20 for Roller Bracket Assembly.

BURNER ASSEMBLY COMPONENT PARTS

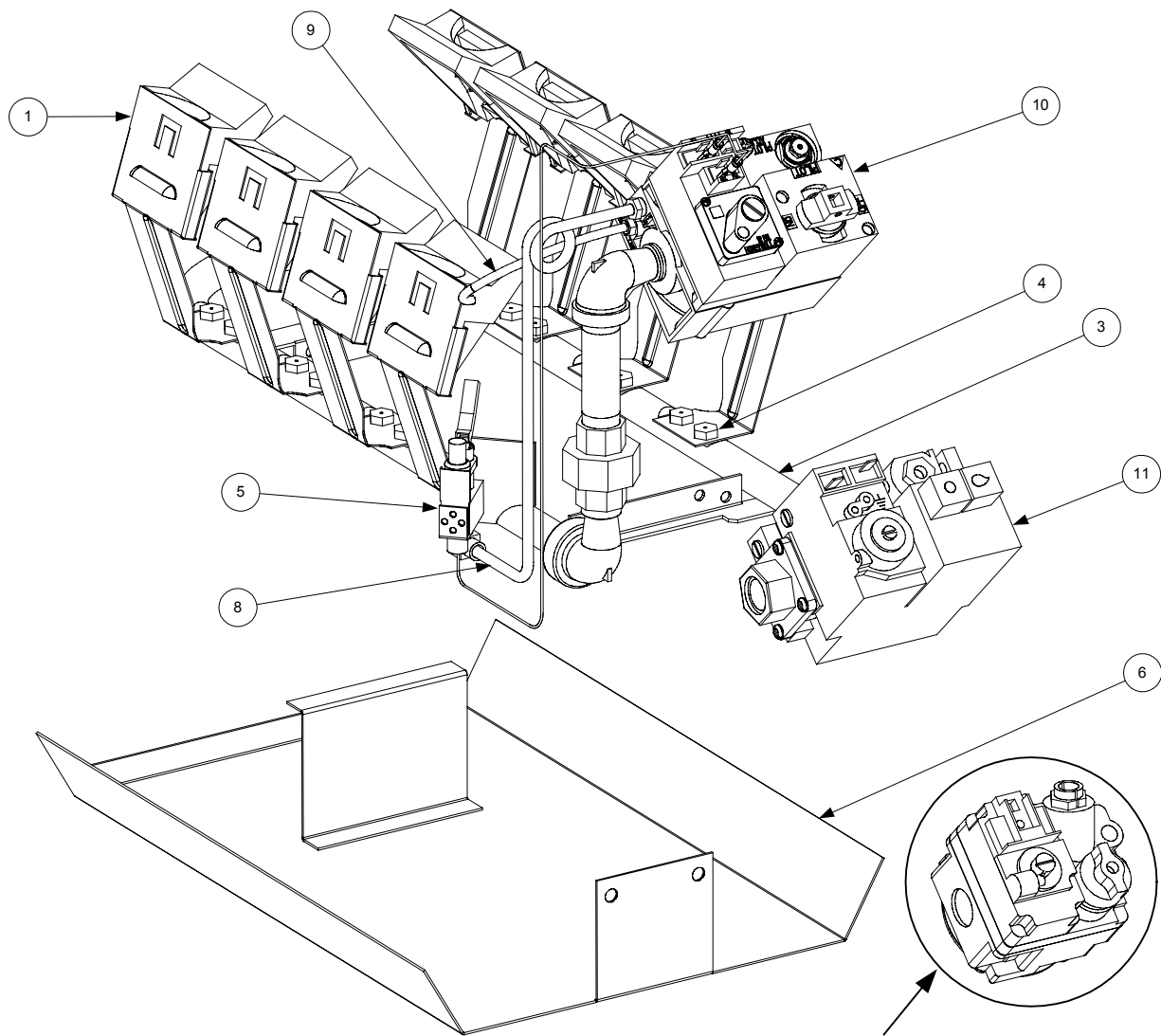

NOTE: Red dot indicates Propane/Butane Pilot Assembly; green dot indicates Manufactured Gas; no dot indicates Natural Gas.

Robertshaw gas valves (illustrated above) are no longer available. Order kit [826-1596](#) to replace natural gas valves, [826-1597](#) to replace propane gas valves, or [826-1643](#) to replace manufactured gas valves.

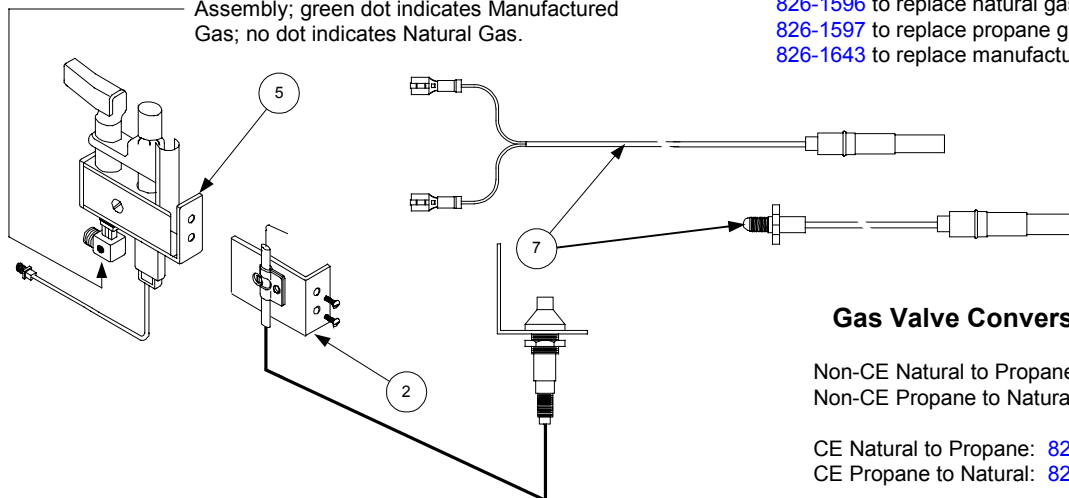

Gas Valve Conversion Kits:

Non-CE Natural to Propane: [826-1143](#)
 Non-CE Propane to Natural: [826-1144](#)

CE Natural to Propane: [826-1200](#)
 CE Propane to Natural: [826-1201](#)

| ITEM | PART # | COMPONENT |
|------|------------|--|
| 1 | 806-0225SP | Deflector (Target) Assembly (use 814-0034 for ceramic only) |
| 2 | 826-1155 | Ignitor Kit, Optional Piezo |
| | 807-1906 | Electrode Assembly |
| | 810-1001 | Trigger |
| 3 | 823-0496 | Manifold, Burner |
| 4 | | Orifice |
| | 810-0407 | Manufactured Gas, 2.15mm (0-1999 Ft) |
| | | Natural Gas |
| | 826-1357 | 1.45mm (0-1999 Ft) (Pkg of 10) |
| | 826-1386 | 1.40mm (2000-3999 Ft) (Pkg of 10) |
| | 810-0361 | 1.36mm (4000-5999 Ft) |
| | 810-0131 | 1.30mm (6000-7999 Ft) |
| | 812-1301 | 1.27mm (8000-8999 Ft) |
| | 810-0343 | 1.25mm (9000-10,000 Ft) |
| | | Propane/Butane Gas |
| | 826-1387 | 0.86mm (0-1999 Ft) (Pkg of 10) |
| | 810-0952 | 0.82mm (2000-3999 Ft) |
| | 810-0339 | 0.81mm (4000-5999 Ft) |
| | 812-0914 | 0.78mm (6000-7999 Ft) |
| | 812-1302 | 0.76mm (8000-8999 Ft) |
| | 812-0444 | 0.74mm (9000-10,000 Ft) |
| 5 | | Pilot Assembly |
| | 810-1830 | Natural Gas, w/Thermopile (non-CE w/twin-leads) |
| | 806-8688SP | Natural Gas, w/Thermocouple (CE w/co-axial lead) |
| | 810-0426 | Natural Gas, w/o Thermopile or Thermocouple |
| | 810-0616 | Propane or Butane Gas, w/Thermopile (non-CE w/co-axial lead) |
| | 810-1773 | Propane or Butane Gas, w/Thermopile (non-CE w/twin leads) |
| | 806-8689SP | Propane or Butane Gas, w/Thermocouple (CE) |
| | 810-0427 | Propane or Butane Gas, w/o Thermopile or Thermocouple) |
| | 810-0683 | Manufactured Gas, w/Thermocouple (CE and non-CE) |
| 6 | 823-0574 | Shield Assembly, Burner Heat |
| 7 | | Thermopile/Thermocouple |
| | 810-1873 | Thermopile w/push-on terminals (used in non-CE Pilot Assemblies) |
| | 826-1527 | Kit, Thermocouple with adapter (used in CE Pilot Assemblies) |
| | 812-1284 | Thermocouple w/threaded terminal (component of 826-1527) |
| 8 | | Tube, Pilot Gas |
| | 810-0705 | For use with all burner assemblies except Hong Kong export units |
| | 812-0278 | For use with Hong Kong export units only |
| 9 | 810-0691 | Tube, Vent |
| 10 | | Valve, Gas (Non-CE) (see Note 1 below) |
| * | 810-0975 | Knob, Gas Valve |
| | 807-3294 | Natural Gas (for 240V, use 807-0025) |
| | 807-3295 | Propane/Butane Gas (for 240V, use 807-0759) |
| | 807-3354 | Manufactured Gas (other than Hong Kong export units) |
| | 810-0353 | Manufactured Gas (Hong Kong export units only) |
| 11 | | Valve, Gas (CE) |
| | 806-6710SP | Natural Gas (see Note 2 below) |
| | 806-6711SP | Propane Gas (see Note 2 below) |

* Not illustrated.

NOTES: **1.** A gas valve capacitor (P/N 806-4781) is required on gas valves used on units with Thermostat Controllers. **2.** An adapter kit (P/N 812-1256SP) is required to connect the high-limit thermostat to Item 11. See Page 2-34 for details.

CABINET ASSEMBLIES AND COMPONENT PARTS

MJ145, F145 (Filter Ready), and Spreader Cabinet Assembly Components

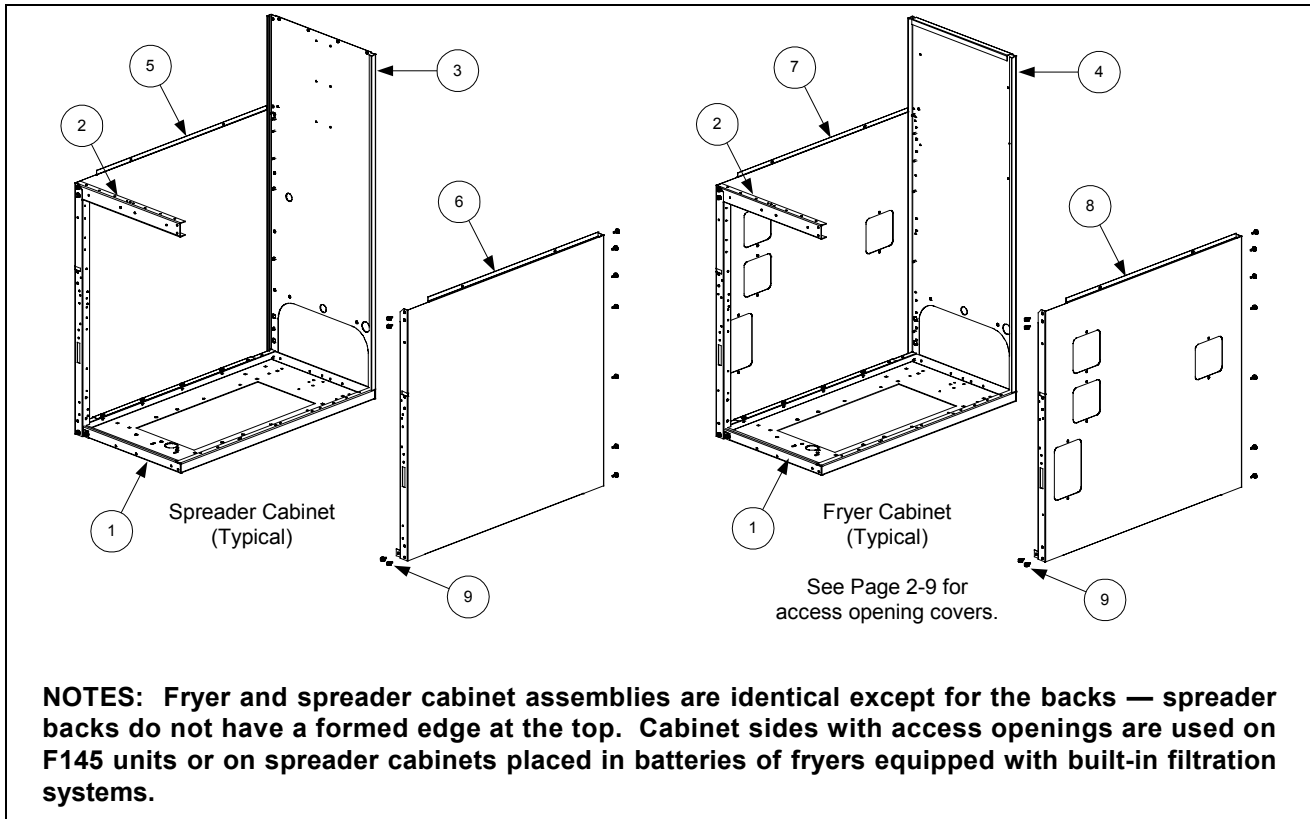

NOTE: See Page 2-14 for casters, legs, and associated hardware, and Page 2-10 for holding station pan components.

| ITEM | PART # | COMPONENT |
|------|------------|---|
| 1 | 900-2568SP | Base, Cabinet, One-Piece |
| 2 | 900-4813SP | Brace, Cabinet Top |
| 3 | | Back, Spreader Cabinet |
| | 910-7213SP | Stainless Steel |
| | 900-7213SP | Aluminized Steel |
| 4 | | Back, Fryer Cabinet |
| | 910-6983SP | Stainless Steel |
| | 900-6983SP | Aluminized Steel |
| 5 | | Side, Left Cabinet w/o Access Openings |
| | 911-9323SP | Stainless Steel |
| | 901-9323SP | Enameled |
| 6 | | Side, Right Cabinet w/o Access Openings |
| | 912-9323SP | Stainless Steel |
| | 902-9323SP | Enameled |
| 7 | | Side, Left Cabinet w/Access Openings |
| | 911-9324SP | Stainless Steel |
| | 901-9324SP | Enameled |
| 8 | | Side, Right Cabinet w/Access Openings |
| | 912-9324SP | Stainless Steel |
| | 902-9324SP | Enameled |
| 9 | 826-1374 | Screw, #10 X 1/2-inch Hex Washer Head (package of 25) |

MJ45 Batteries

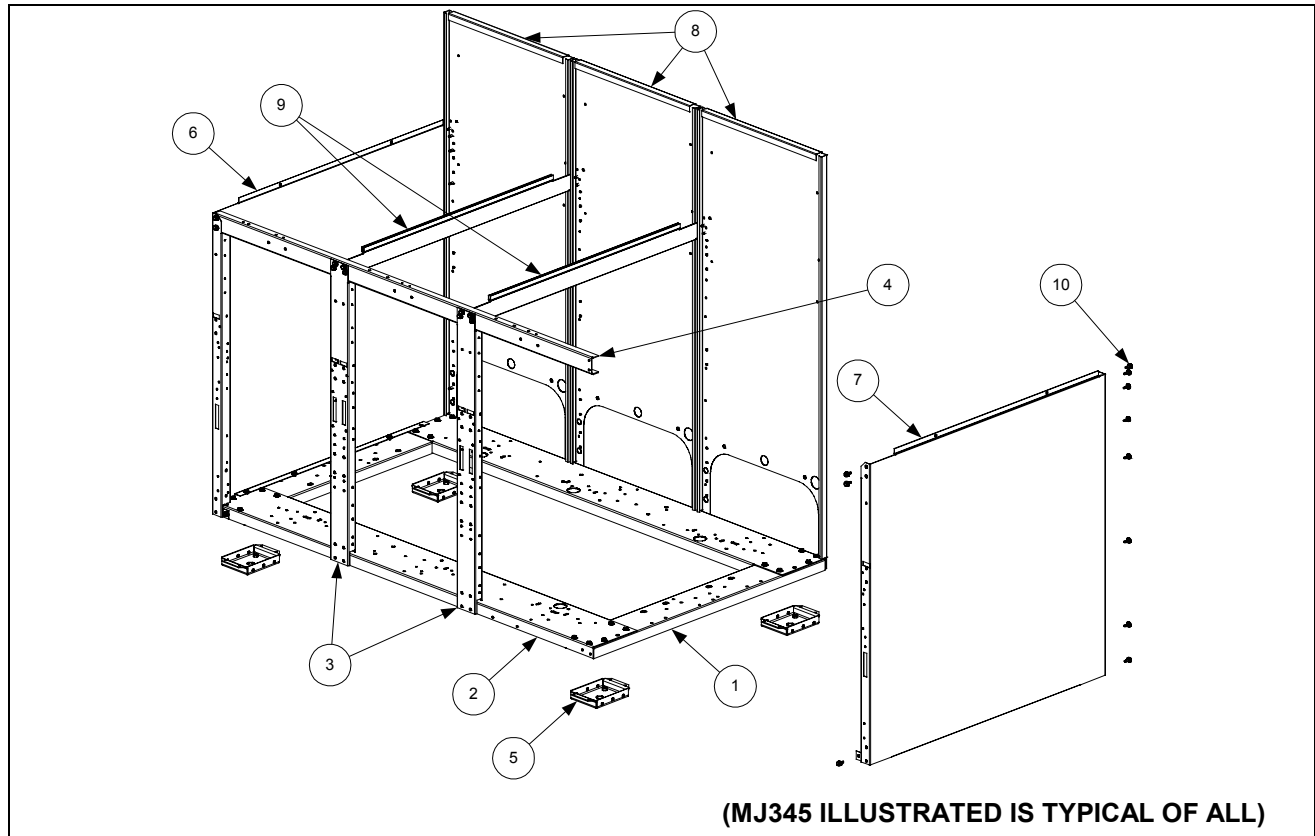

NOTE: See Page 2-14 for casters, legs and associated hardware.

| ITEM | PART # | COMPONENT |
|------|------------|---|
| 1 | 900-4426SP | Channel, Left and Right Side |
| 2 | | Channel, Front and Rear |
| | 900-2395SP | Double |
| | 900-2396SP | Triple |
| | 900-9373 | Quad |
| 3 | 900-6979SP | Post, Door |
| 4 | | Brace, Cabinet Top |
| | 900-7730SP | Double |
| | 900-9430SP | Triple |
| | 900-9318 | Quad |
| 5 | 806-5209SP | Leg Pad Assembly |
| 6 | | Side, Left Cabinet |
| | 911-9323SP | Stainless Steel (<i>use 911-9324SP for side with access openings</i>) |
| | 901-9323SP | Enameled (<i>use 901-9324SP for side with access openings</i>) |
| 7 | | Side, Right Cabinet |
| | 912-9323SP | Stainless Steel (<i>use 912-9324SP for side with access openings</i>) |
| | 902-9323SP | Enameled (<i>use 902-9324SP for side with access openings</i>) |
| 8 | | Back, Cabinet |
| | 910-6983SP | Stainless Steel |
| | 900-6983SP | Aluminized Steel |
| 9 | 900-7326 | Divider, Cabinet |
| 10 | 826-1374 | Screw, #10 X 1/2-inch Hex Washer Head (package of 25) |

FM45 Batteries with Built-In Filtration

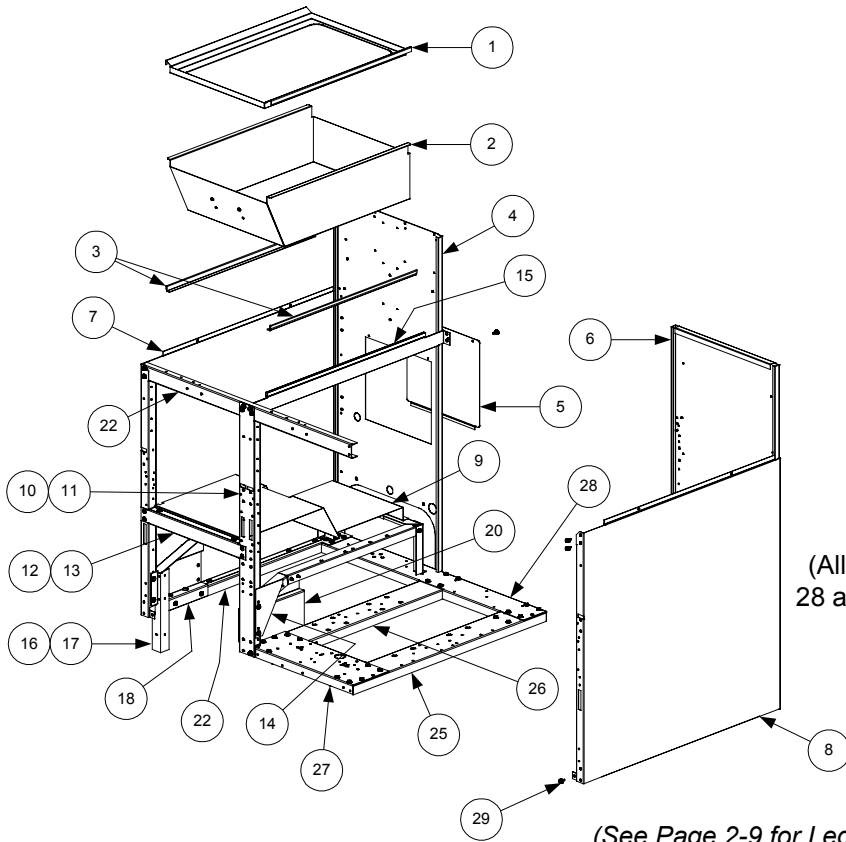

NOTE: Items 1-15 are used in all FM45 Built-In Filter configurations and therefore are not repeated for the FM245 and FM145 (Filter on Right) illustrations.

FM145 (FILTER ON LEFT)
 (All components except Items 27 and 28 are the same for FM245 and FM345 units with the filter on the left.)

(See Page 2-9 for Leg Pad Assembly)

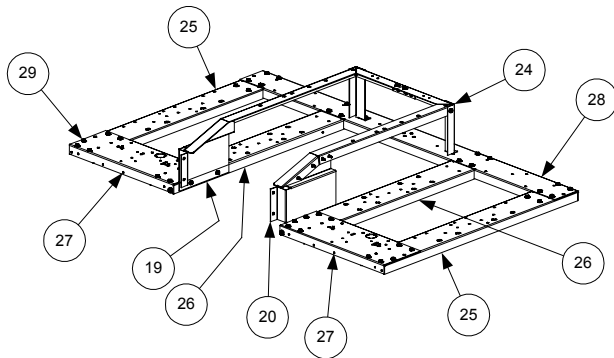

FM245 (FILTER BETWEEN FRYERS)
 (All components except Items 27 and 28 are the same for FM345 cabinets with the filter between fryers.)

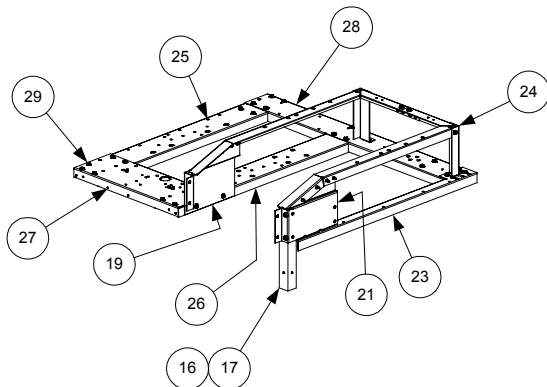

FM145 (FILTER ON RIGHT)
 (All components except Items 27 and 28 are the same for FM245 and FM345 units with the filter on the right.)

| ITEM | PART # | COMPONENT |
|------|------------|---|
| 1 | 910-7480 | Trim, Filter Cabinet Top |
| 2 | 806-8274SP | Pan Assembly, Filter/Spreader Cabinet |
| 3 | 900-7277 | Support, Drain Pan |
| 4 | | Back w/Access Opening, Filter Cabinet |
| | 910-7274SP | Stainless Steel |
| | 900-7274SP | Aluminized Steel |
| 5 | 900-4089 | Cover, Cabinet Back Access |
| 6 | | Back, Cabinet |
| | 910-6983SP | Stainless Steel |
| | 900-6983SP | Aluminized Steel |
| 7 | | Side, Left Cabinet |
| | 911-9323SP | Stainless Steel |
| | 901-9323SP | Enameled |
| 8 | | Side, Right Cabinet |
| | 912-9323SP | Stainless Steel |
| | 902-9323SP | Enameled |
| 9 | 900-7414 | Shield, Filter Magic Pan |
| 10 | 900-6979SP | Post, Door |
| 11 | 809-0413 | Spacer, .25 x .160 8 Gauge Nylon (located behind Item 10 at bottom) |
| 12 | 900-4391SP | Brace, Front Cabinet |
| 13 | 826-1379 | Screw, #10 x ½-inch Philips Truss Head (package of 10) |
| 14 | 900-1700 | Bracket, Drain Support |
| 15 | 900-7314SP | Divider, Cabinet |
| 16 | 910-1601 | Leg, Filter |
| 17 | 900-1621 | Plate, Rail Mount (located inside front edge of Item 7) |
| 18 | 901-1599 | Bracket, Left Pan Rail (used on cabinets with filter on left) |
| 19 | 901-1595 | Bracket, Left Pan Rail (used on cabinets with filter on right or in middle) |
| 20 | 902-1599 | Bracket, Right Pan Rail (used on cabinets with filter in middle) |
| 21 | 902-1595 | Bracket, Right Pan Rail (used on cabinets with filter on right) |
| 22 | 901-4390 | Channel, Left Filter Side |
| 23 | 902-4390 | Channel, Right Filter Side |
| 24 | 806-4917 | Rail Assembly, Filter Magic |
| 25 | 900-4426 | Channel, Fryer Outside |
| 26 | 900-4383 | Channel, Fryer Inside |
| 27 | | Channel, Fryer Front |
| | 900-2394 | Single Fryer |
| | 900-2395 | Double Fryer |
| | 900-2396 | Triple Fryer |
| 28 | | Channel, Filter Magic Cabinet Rear |
| | 900-1631 | FM145 Filter Left |
| | 900-7243 | FM245 Filter Left |
| | 900-9319 | FM345 Filter Left |
| | 900-1630 | FM145 Filter Right |
| | 900-7244 | FM245 Filter Right |
| | 900-9322 | FM345 Filter Right |
| | 900-7242 | FM245 Filter Middle |
| | 900-9321 | FM345 (Fryer, Fryer, Filter, Fryer) |
| | 900-9320 | FM345 (Fryer, Filter, Fryer, Fryer) |
| 29 | 826-1374 | Screw, #10 X ½-inch Hex Washer Head (package of 25) |

Filter Magic II Add-On Cabinet Components

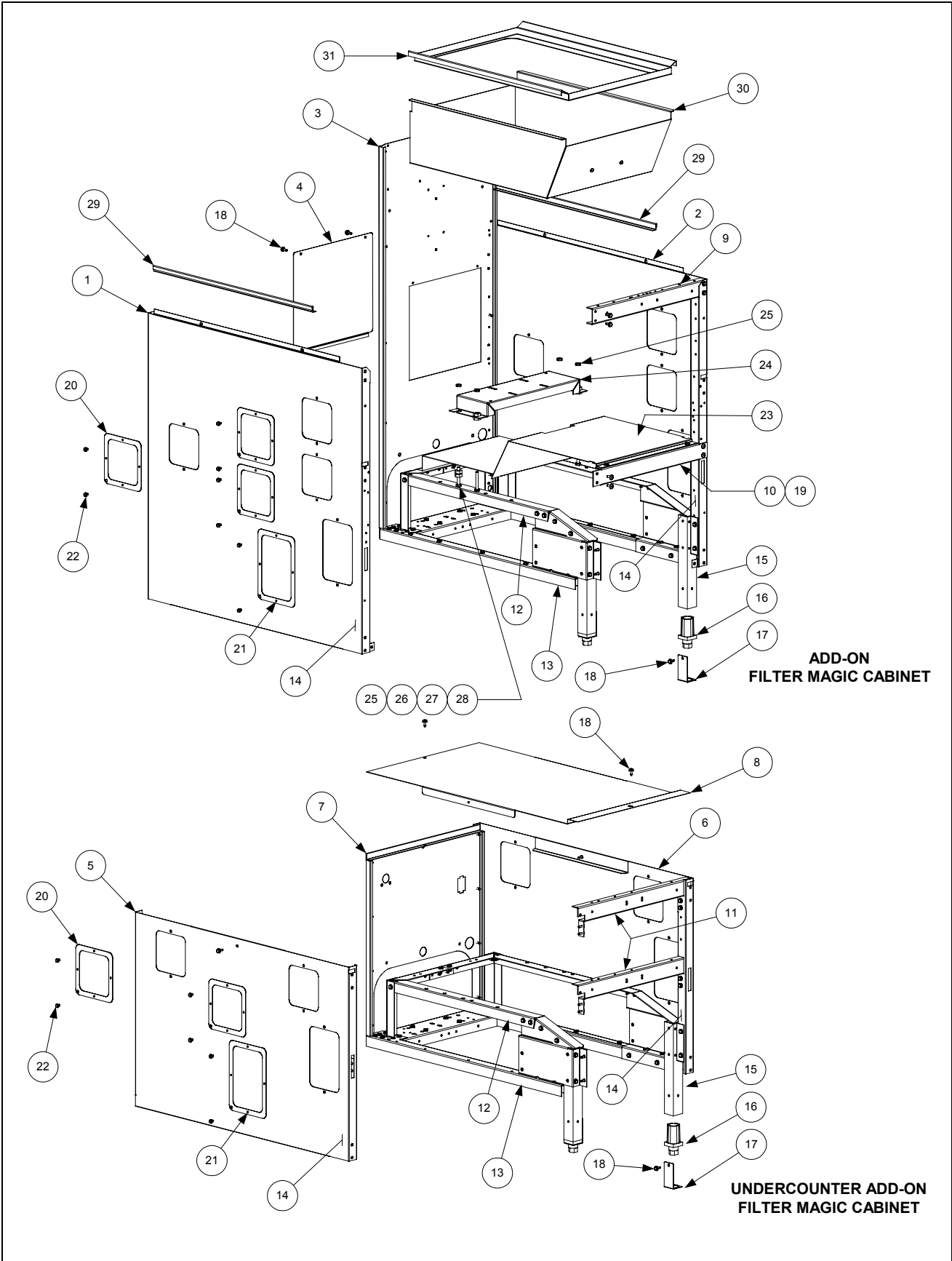

| ITEM | PART # | COMPONENT |
|------|------------|---|
| 1 | | Side, Left Cabinet, w/Access Openings |
| | 911-9324SP | Stainless Steel |
| | 901-9324SP | Enameled |
| 2 | | Side, Right Cabinet, w/Access Openings |
| | 912-9324SP | Stainless Steel |
| | 902-9324SP | Enameled |
| 3 | | Back w/Access Opening, Filter Cabinet |
| | 910-7274SP | Stainless Steel |
| | 900-7274SP | Aluminized Steel |
| 4 | | Cover, Cabinet Back Access |
| | 910-4089 | Stainless Steel |
| | 900-4089 | Aluminized Steel |
| 5 | | Side, Left Undercounter Cabinet |
| | 911-7677SP | Stainless Steel |
| | 901-7677SP | Enameled |
| 6 | | Side, Right Undercounter Cabinet |
| | 912-7677SP | Stainless Steel |
| | 902-7677SP | Enameled |
| 7 | | Back, Undercounter Cabinet |
| | 910-4786 | Stainless Steel |
| | 900-4786 | Aluminized Steel |
| 8 | 910-7680 | Cover, Undercounter Cabinet |
| 9 | 900-4813SP | Brace, Cabinet Top |
| 10 | 900-4391SP | Brace, Cabinet Front |
| 11 | 900-4785 | Brace, Undercounter Cabinet Top and Center |
| 12 | 806-5317SP | Rail Assembly |
| 13 | 806-4897SP | Base Assembly (<i>includes leg pad assembly 806-5209 (see Page 2-13)</i>) |
| 14 | 900-1621 | Plate, Rail Mount (located inside lower front edge of Items 1, 2, 5, and 6) |
| 15 | 910-1601 | Leg, Filter Cabinet (<i>use 910-8673 on units with rear casters</i>) |
| 16 | 810-0007 | Leg, Adjustable |
| 17 | 910-1832 | Retainer, Leg Insert, Full Height |
| 18 | 826-1374 | Screw, #10 X ½-inch Hex Washer Head (Pkg. of 25) |
| 19 | 826-1379 | Screw, #10 X ½-inch Philips Truss Head (Pkg. of 10) |
| 20 | | Cover, 4-inch X 4-inch Access Opening |
| | 910-0889 | Stainless Steel |
| | 900-0889 | Enameled |
| 21 | | Cover, 4-inch X 4-inch Access Opening |
| | 910-0890 | Stainless Steel |
| | 900-0890 | Enameled |
| 22 | 809-0359 | Screw, #8 X ¼-inch Hex Washer Head (for access covers) |
| 23 | 900-7414 | Shield, FM Pan |
| 24 | 900-4175 | Mount, Motor |
| 25 | 826-1362 | Nut, ¼-20 Hex (Pkg. of 10) |
| 26 | 809-0429 | Bolt, ¼-20 X 2-inch Hex Head |
| 27 | 809-0191 | Washer, ¼-inch Lock |
| 28 | 810-0665 | Nut, ¼-20 Hex Leveling |
| 29 | 900-7277 | Support, Holding Station Pan |
| 30 | 806-8274SP | Pan Assembly, Holding Station |
| 31 | 910-7480 | Trim, Holding Station |

CASTERS, LEGS, AND ASSOCIATED HARDWARE

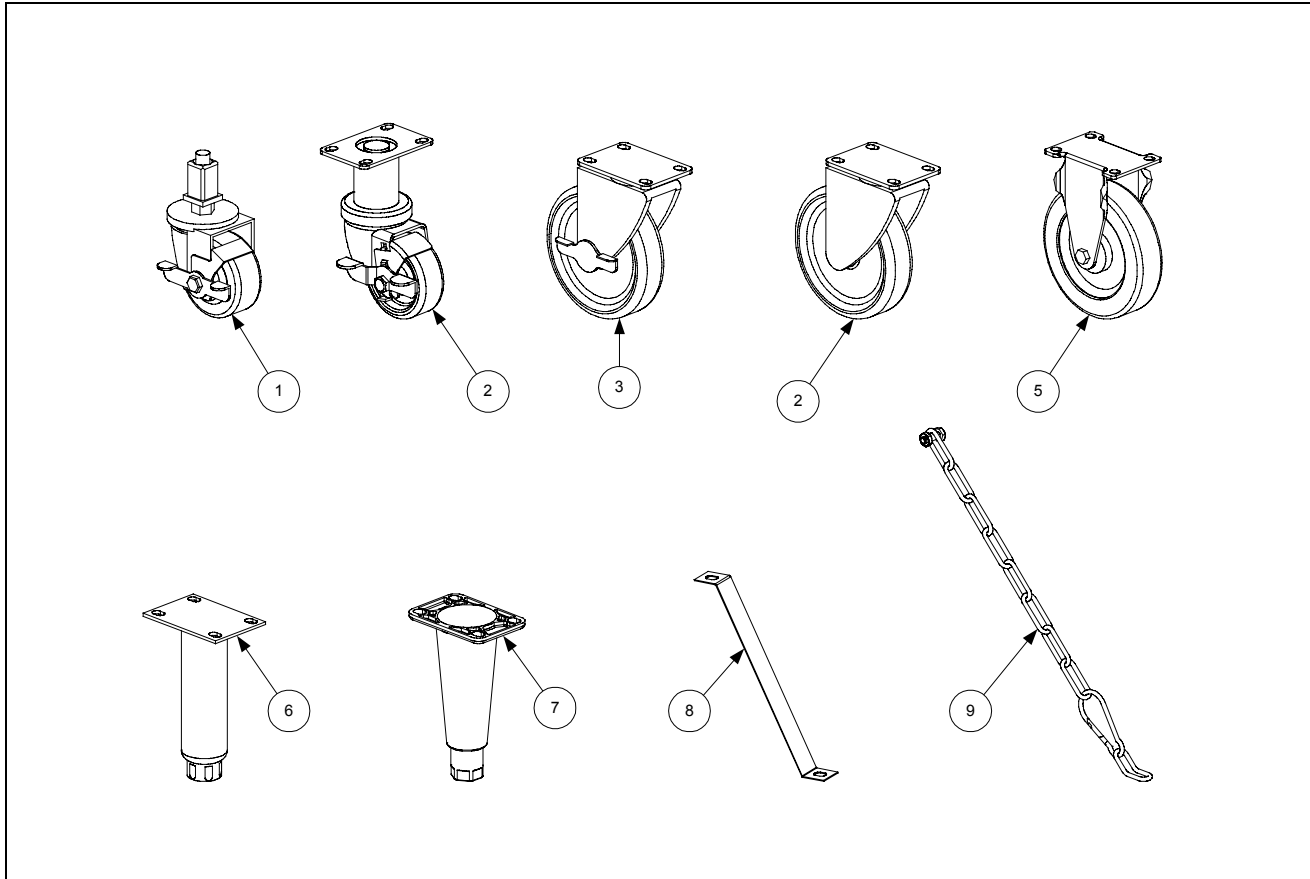

| ITEM | PART # | COMPONENT |
|------|----------|---|
| 1 | 823-2669 | Caster, 3" Swivel w/Brake (<i>optional substitute for front leg in FM add-on cabinet</i>) |
| 2 | 826-1130 | Caster, 3" Swivel w/Brake (810-0651 and mounting hardware) |
| 3 | 826-1118 | Caster, 5" Swivel w/Brake (810-0357 and mounting hardware) |
| 4 | 826-1117 | Caster, 5" Swivel w/o Brake (810-0356 and mounting hardware) |
| 5 | 826-1138 | Caster, 5" Rigid w/o Brake (810-0378 and mounting hardware) |
| 6 | 826-1237 | Leg Assembly, Stainless Steel |
| 7 | 826-1115 | Leg Assembly, Nickel Plated |
| 8 | 826-1095 | Anchor Strap Kit (for use on single fryers w/legs) |
| 9 | 826-0900 | Chain Restraint Kit (for use on fryers w/casters) |
| * | 826-1113 | Kit, Mounting Hardware, 1 Caster/Leg (4 mounting bolts and lock washers) |
| * | 826-1098 | Kit, Mounting Hardware, 2 Casters/Legs (8 mounting bolts and lock washers) |
| * | 826-1043 | Kit, Mounting Hardware, 4 Casters/Legs (16 mounting bolts and lock washers) |

* Not illustrated.

NOTE: Items 2 through 8 include 1 caster or leg, 4 mounting bolts, and 4 lock washers.

COMPONENT SHIELDS, FILTER BOX ASSEMBLIES, AND COMPONENT PARTS

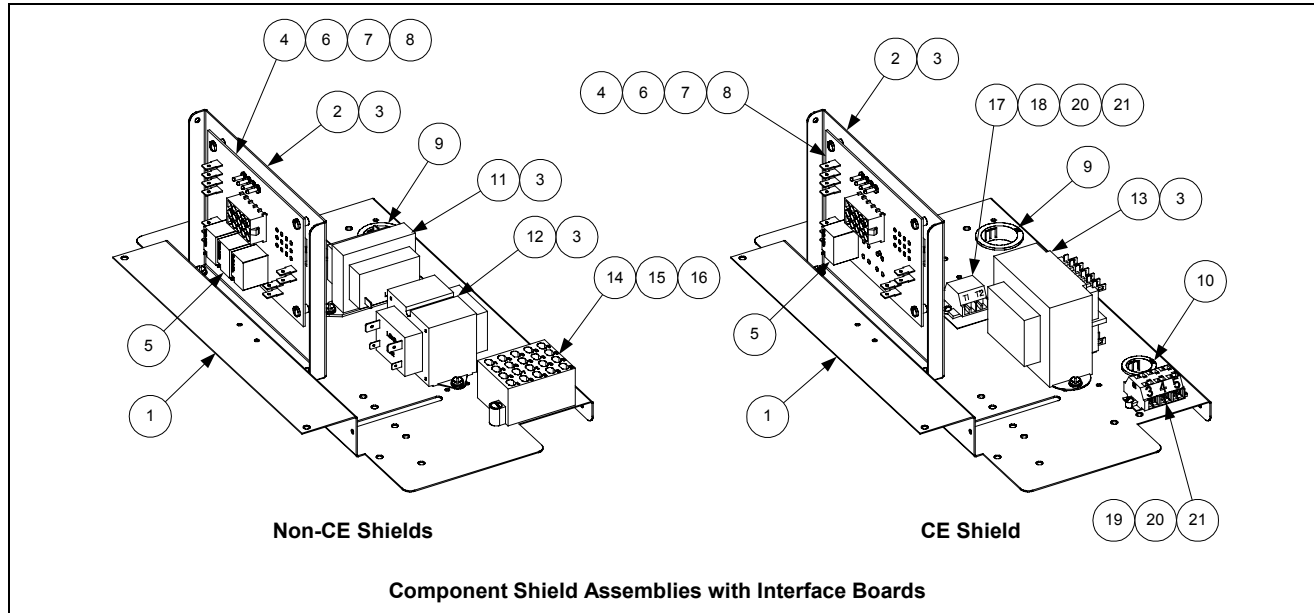

| ITEM | PART # | COMPONENT |
|------|------------|--|
| | | Complete Shield Assemblies |
| | 806-4773SP | 100-120V, 50/60 Hz (Non-CE) |
| | 806-4775SP | 208-240V, 50/60 Hz (Non-CE) |
| | 806-6629SP | 230V, 50 Hz (CE) |
| | | Components |
| 1 | 900-4340 | Shield, Component |
| 2 | 824-0161 | Support, Interface Board |
| 3 | 809-0360 | Screw, #8 X 3/8-inch Washer Slotted Hex Head |
| 4 | | Interface Board |
| | 806-3548 | Non-CE Universal Replacement |
| | 806-7505 | CE Universal Replacement |
| 5 | 807-1582 | Relay, 12VDC |
| * | 810-2243 | Clip, Relay Retaining |
| 6 | 809-0349 | Spacer, 4 x 6 mm, Interface Board Standoff |
| 7 | 809-0096 | Screw, 6-32 X 5/8-inch Slot Head |
| 8 | 809-0250 | Nut, 6-32 Hex Keys |
| 9 | 807-2469 | Bushing, Heyco (fits 7/8-inch (.875-inch) hole) |
| 10 | 810-0045 | Bushing, Heyco (fits 1.25-inch hole) |
| 11 | | Transformer, 12V Secondary |
| | 807-0855 | 100-120V 50/60 Hz Primary |
| | 807-0979 | 208-240V 50/60 Hz Primary |
| 12 | | Transformer, 24V Secondary |
| | 807-0800 | 100-120V 50/60 Hz Primary |
| | 807-0680 | 208-240V 50/60 Hz Primary |
| 13 | 807-1999 | Transformer, 208-240V Primary/12V and 24V Secondary Dual Voltage |
| 14 | 807-0066 | Terminal Block, 20-Position |
| 15 | 809-0097 | Screw, 6-32 X 1-inch Slotted Round Head |
| 16 | 826-1358 | Nut, 6-32 Hex (Pkg. of 25) |
| 17 | 816-0217 | Paper, Insulating |
| 18 | 810-1164 | Terminal Block, 6-Position |
| 19 | 810-1168 | Terminal Block, 8-Position |
| 20 | 826-1359 | Screw, 4-40 X 3/4-inch Slotted Round Head (Pkg. of 25) |
| 21 | 826-1366 | Nut, 4-40 Hex Keys (Pkg. of 25) |

* Not illustrated.

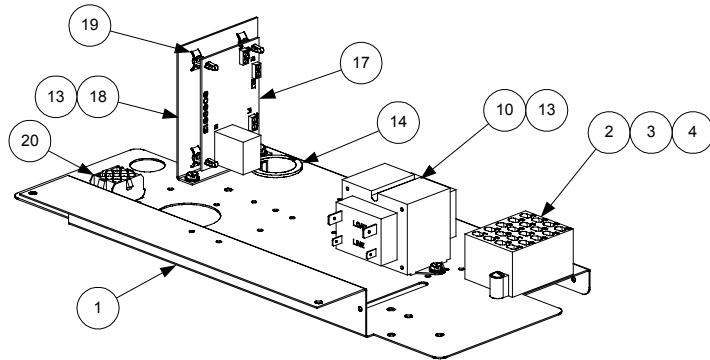

100-120V Non CE

Electromechanical timer shown for identification purposes only. This timer has been replaced by Items 17, 18, and 19 (shown in the 100-120V illustration) in all applications.

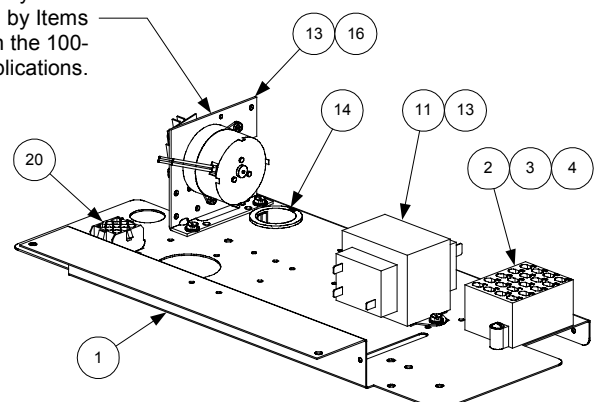

208-240V Non-CE

NOTE: Melt cycle timers (Items 16 and 17) are not present in shield assemblies [806-4774SP](#), [806-4776SP](#), and [806-6630SP](#).

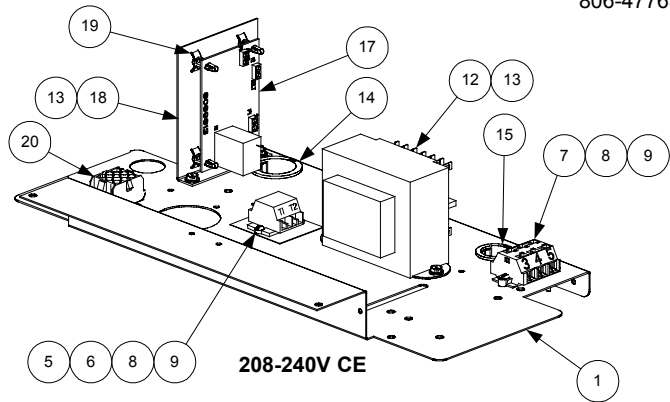

208-240V CE

Component Shield Assemblies without Interface Boards

| ITEM | PART # | COMPONENT |
|------|------------|---|
| | | Complete Shield Assemblies |
| | 806-4774SP | 120V, 50/60 Hz without Melt Cycle Timer (Non-CE) |
| | 806-4776SP | 240V, 50/60 Hz without Melt Cycle Timer (Non-CE) |
| | 806-4772SP | 120V, 50/60 Hz with Melt Cycle Timer (Non-CE) |
| | 806-4777SP | 240V, 50/60 Hz with Melt Cycle Timer (Non-CE) |
| | 806-6630SP | 230V, 50 Hz without Melt Cycle Timer (CE) |
| | 806-6632SP | 230V, 50 Hz with Melt Cycle Timer (CE) |
| | | Components |
| 1 | 900-4340 | Shield, Component |
| 2 | 807-0066 | Block, Terminal, 20-Pin |
| 3 | 809-0097 | Screw, 6-32 x 1-inch Slotted Truss Head |
| 4 | 826-1358 | Nut, 6-32 Hex (Pkg. of 25) |
| 5 | 816-0217 | Paper, Insulating |
| 6 | 810-1164 | Terminal Block, 6-Position |
| 7 | 810-1168 | Terminal Block, 8-Position |
| 8 | 826-1359 | Screw, 4-40 X ¾-inch Slotted Round Head (Pkg. of 25) |
| 9 | 826-1366 | Nut, 4-40 Hex Keys (Pkg. of 25) |
| 10 | 807-0800 | Transformer, 100-120V Primary/24V Secondary 50/60 Hz 50VA |
| 11 | | Transformer, 208-240V Primary/24V Secondary 50/60 Hz |
| | 807-0680 | 20VA without fuse |
| | 807-2180 | 50 VA with fuse |
| * | 807-1597 | Fuse, 3-Amp Slow-Blow (for use w/transformer 807-2180) |
| 12 | 807-1999 | Transformer, 208-240V Primary/12V and 24V Secondary Dual Voltage |
| 13 | 826-1374 | Screw, #10 x ½-inch Hex Washer Head (Pkg of 25) |
| 14 | 810-0045 | Bushing, Heyco (fits 1.25-inch hole) |
| 15 | 807-2469 | Bushing, Heyco (fits ⅞-inch (.875-inch) hole) |
| 16 | 826-1546 | Kit, Melt Cycle Timer (Items 17, 18, and 19) replaces electromechanical timer |
| 17 | 806-9613 | PC Board Assembly, Melt Cycle Timer (50 and 60 Hz) |
| 18 | 900-8741 | Bracket, Melt Cycle Timer |
| 19 | 809-0580 | Standoff, PC Board |
| 20 | 807-0156 | Plug, 9-Pin |

* Not illustrated.

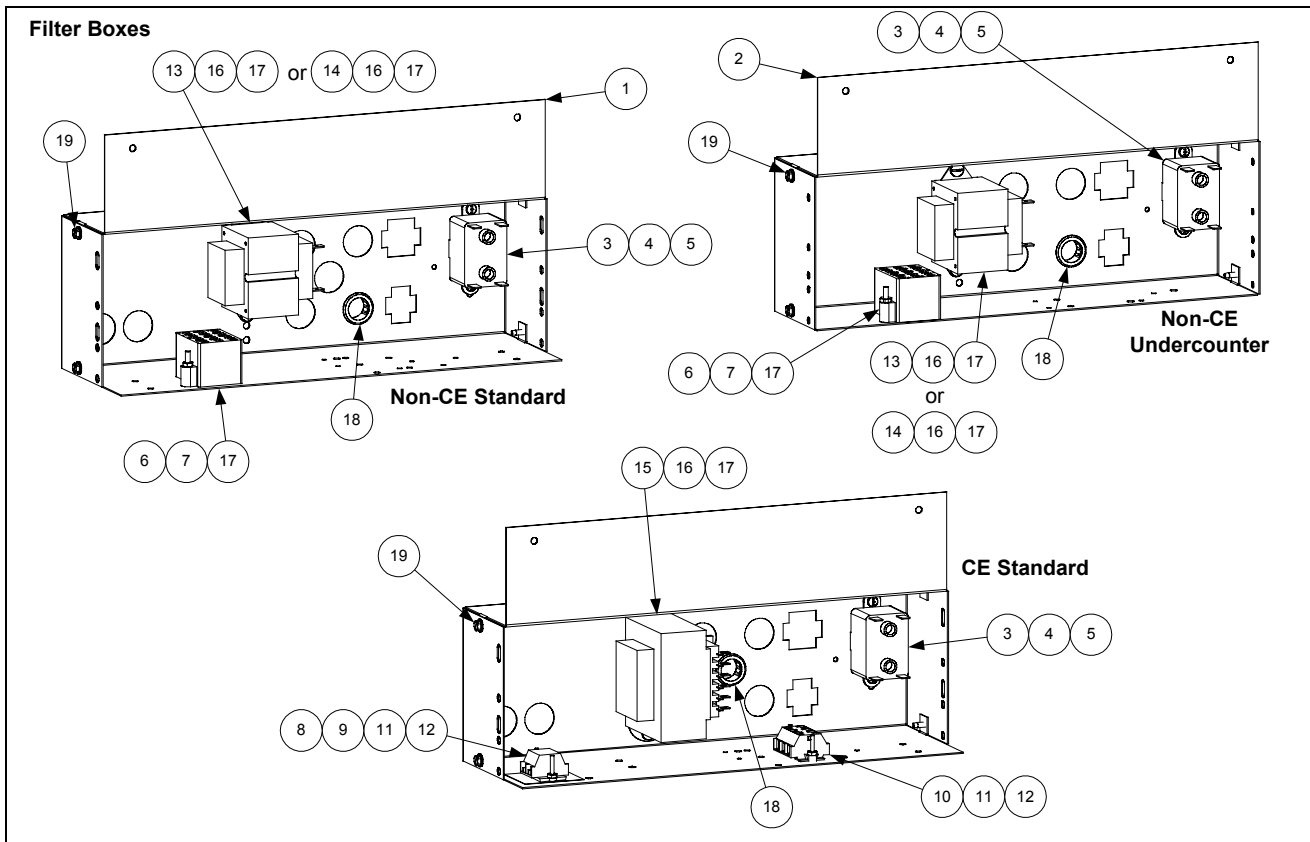

| ITEM | PART # | COMPONENT |
|------|------------|---|
| | | Complete Box Assembly |
| | 806-4359SP | 100-120V Standard Cabinet |
| | 806-4360SP | 208-240V Standard Cabinet (Non-CE) |
| | 806-6709SP | 230V Standard Cabinet (CE) |
| | 806-4361SP | 100-120V Undercounter Cabinet |
| | 806-4362SP | 208-240V Undercounter Cabinet (Non-CE) |
| | | Components |
| 1 | 200-0409 | Box, Standard Filter Control |
| 2 | 200-0410 | Box, Undercounter Filter Control |
| 3 | 807-0012 | Relay, 15 Amp, SPST, Filter |
| 4 | 809-0096 | Screw, 6-32 X 5/8-inch Slot Head |
| 5 | 826-1358 | Nut, 6-32 Hex (Pkg. of 25) |
| 6 | 807-0276 | Terminal Block, 20-Position |
| 7 | 809-0097 | Screw, 6-32 X 1-inch Slotted Round Head |
| 8 | 816-0217 | Paper, Insulating |
| 9 | 810-1164 | Terminal Block, 6-Position |
| 10 | 810-1168 | Terminal Block, 8- Position |
| 11 | 826-1359 | Screw, 4-40 X 3/4-inch Slotted Round Head (Pkg. of 25) |
| 12 | 826-1366 | Nut, 4-40 Hex Keys (Pkg. of 25) |
| 13 | 807-0800 | Transformer, 100-120V Primary/24V Secondary 50/60 Hz 50VA |
| 14 | 807-0680 | Transformer, 208-240V Primary/24V Secondary 50/60 Hz 20VA |
| 15 | 807-1999 | Transformer, 208-240V Primary/12V & 24V Secondary Dual Voltage (CE) |
| 16 | 809-0103 | Screw, 8-32 X 1/2-inch Slotted Truss Head |
| 17 | 809-0050 | Nut, 8-32 Hex |
| 18 | 807-0124 | Bushing, Heyco (fits 7/8-inch (.875-inch) hole) |
| 19 | 809-0360 | Screw, #8 X 3/8-inch Washer Slotted Hex Head |

THIS PAGE INTENTIONALLY LEFT BLANK

CONTROL PANEL ASSEMBLIES, FLUE CAPS, TOP CAPS, and RELATED ITEMS

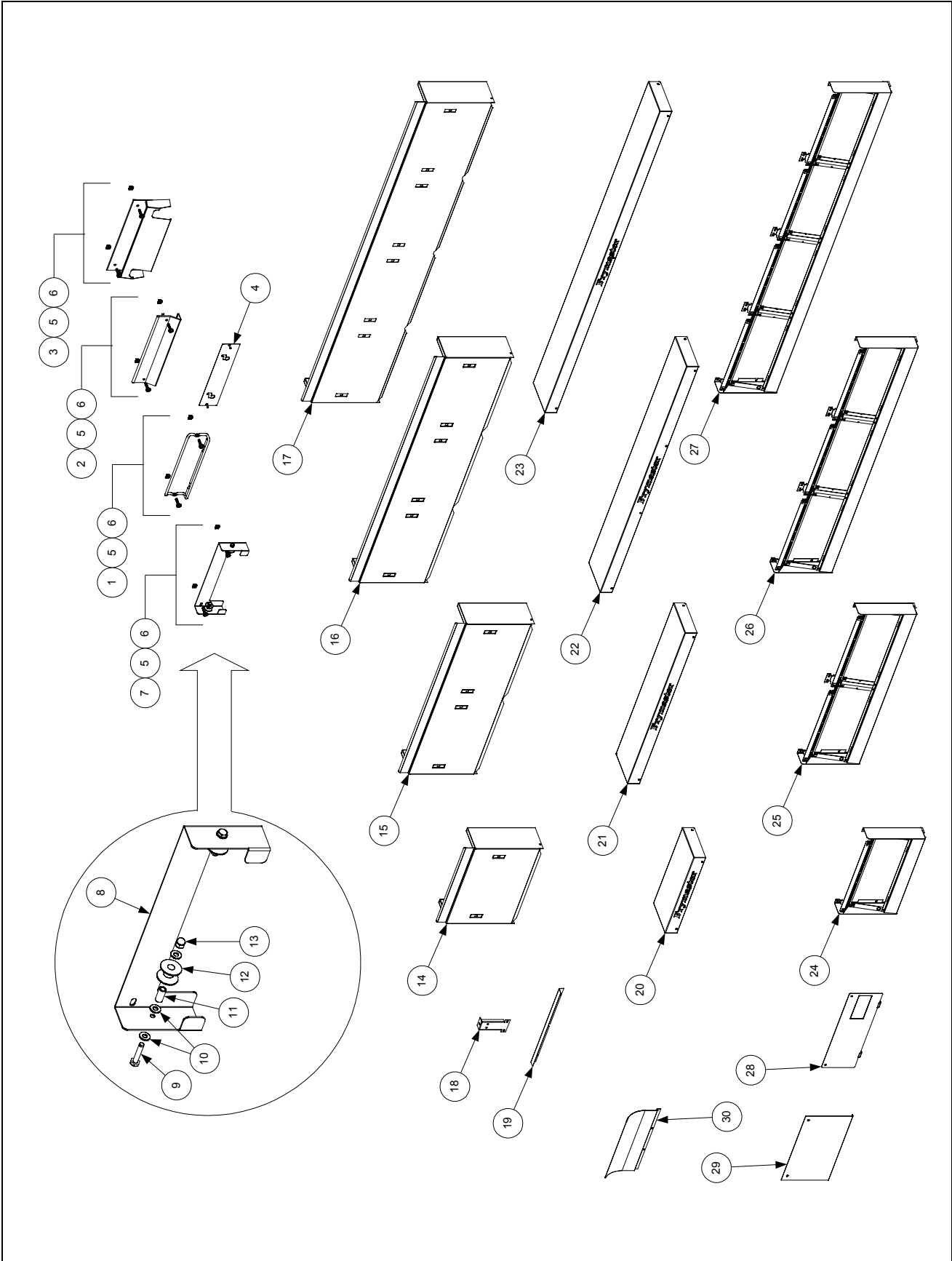

| ITEM | PART # | COMPONENT |
|------|------------|--|
| 1 | 810-1403 | Basket Hanger, Wire Form |
| * | 809-0921 | Spacer, Wire Form Basket Hanger |
| 2 | | Basket Hanger, Extruded Aluminum (No longer available; use 810-1403) |
| 3 | 823-1462 | Basket Hanger, Burger King |
| 4 | 106-2185 | Bracket, Burger King Easy-Off Basket Hanger (used w/Item 1) |
| 5 | 809-0171 | Thumbscrew, ¼-20 X 1⅝-inch Basket Hanger |
| 6 | 826-1351 | Nut, Cage (receives Basket Hanger Thumbscrew) (pkg of 10) |
| 7 | 806-9257SP | Roller Assembly, Basket Lift (Complete) |
| 8 | 910-8284 | Bracket, One-Piece Roller Guide |
| 9 | 826-1334 | Capscrew, ¼ – 20 x 1¼” Stainless Steel Hex Head (pkg of 5) |
| 10 | 809-0190 | Washer, ¼” Stainless Steel Flat |
| 11 | 810-0374 | Spacer, Tubular |
| 12 | 810-0194 | Roller, Basket Lift Guide |
| 13 | 809-0047 | Nut, ¼ – 20 Cap (also used w/Item 4) |
| 14 | | Flue Cap, Single Fryer, w/lip |
| | 910-5018 | Standard |
| | 910-6545 | Optional (without lip along flue opening) |
| | 823-3749 | Burger King with Button Studs (used w/Item 4) |
| 15 | | Flue Cap, 2-Fryer Battery |
| | 823-2540 | Standard |
| | 823-3536 | Burger King with Button Studs (used w/Item 4) |
| 16 | | Flue Cap, 3-Fryer Battery |
| | 823-2541 | Standard |
| | 823-3537 | Burger King with Button Studs (used w/Item 4) |
| 17 | 823-2569 | Flue Cap, 4-Fryer Battery |
| 18 | 900-5486 | Support, Flue Cap |
| 19 | 900-4253 | Flue Cap Retaining Strip |
| 20 | 824-0404 | Top Cap, Single Fryer |
| 21 | 824-0405 | Top Cap, Two-Fryer Battery |
| 22 | 824-0406 | Top Cap, Three-Fryer Battery |
| 23 | 824-0407 | Top Cap, Four-Fryer Battery |
| 24 | 806-4732SP | Control Panel Assembly, Single Fryer |
| 25 | 806-4733SP | Control Panel Assembly, 2-Fryer Battery |
| 26 | 806-4734SP | Control Panel Assembly, 3-Fryer Battery |
| 27 | 806-5018SP | Control Panel Assembly, 4-Fryer Battery |
| 28 | 910-8503 | Panel, FM Standard Cabinet Front |
| 29 | 910-8505 | Panel, FM Undercounter Cabinet Front |
| 30 | 910-3557 | Flue Deflector |
| * | 826-1379 | Screw, #10 X ½-inch Philips Head (pkg of 10) (attaches top cap) |
| * | 826-1371 | Screw, #8 X ½-inch Hex Washer Head (pkg of 25) (attaches flue cap) |

* Not illustrated.

CONTROLLER ASSEMBLIES (Thermostat Controllers)

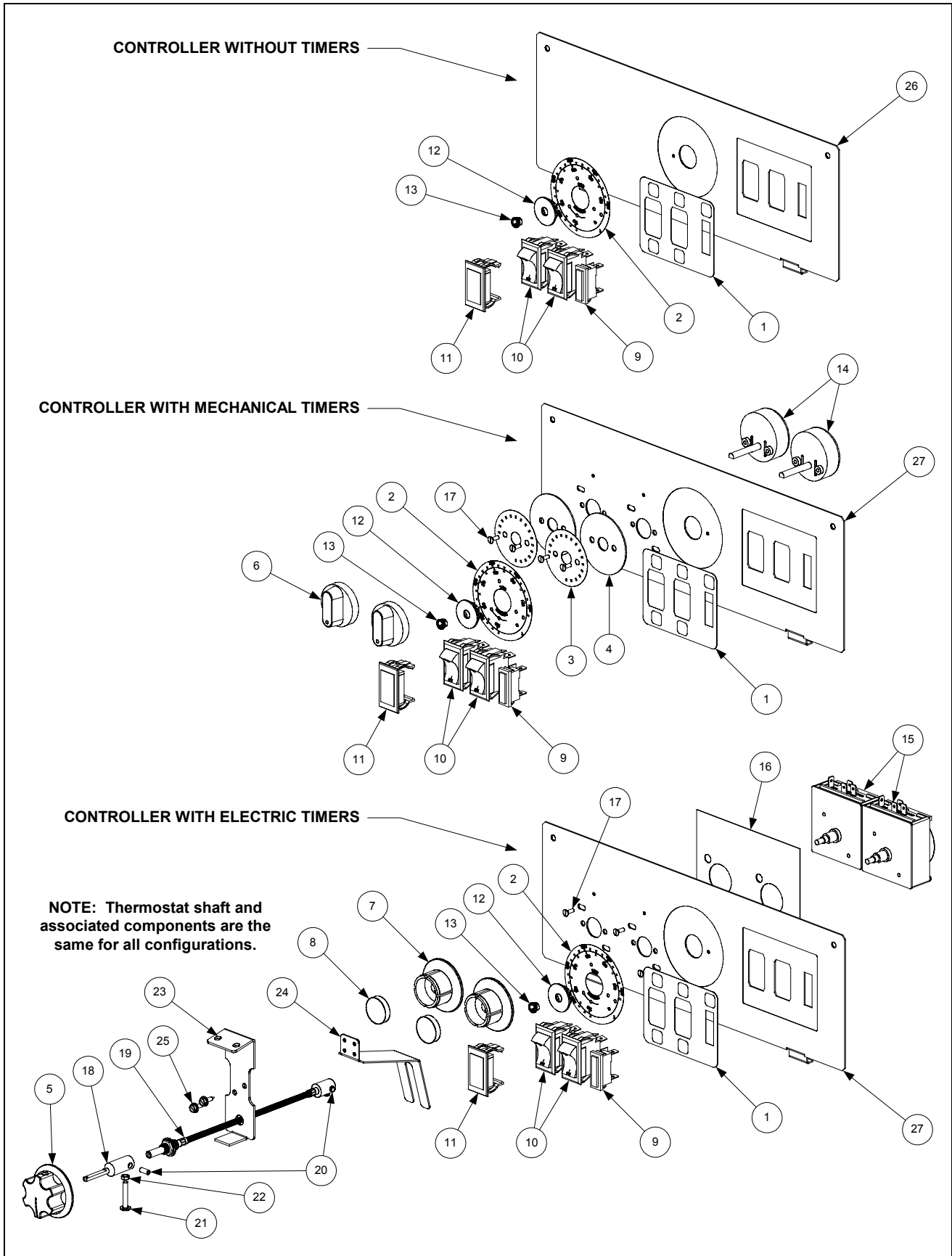

| ITEM | PART # | COMPONENT |
|------|----------|--|
| 1 | 802-0765 | Label, Control Panel |
| 2 | 802-1470 | Label, Thermostat Dial |
| 3 | 802-1473 | Label, 15-Minute Mechanical Timer Bezel |
| 4 | 910-1551 | Bezel, 15-Minute Mechanical Timer |
| 5 | 810-0334 | Knob, Operating Thermostat |
| 6 | 810-1287 | Knob, 15-minute Mechanical Timer |
| 7 | 810-1822 | Knob, 15-Minute Electrical Timer Replacement |
| 8 | 810-1823 | Push Button, White 15-Minute Electrical Timer Replacement |
| 9 | 807-1525 | Light, White Melt Cycle Indicator, 24V |
| 10 | 807-3498 | Switch, Melt Cycle Rocker, 24V |
| 11 | 807-3575 | Plug, Blank Switch (used on units without melt cycle option) |
| 12 | 826-1395 | Plug, Snap-in Reducer, S/S (Pkg of 10) |
| 13 | 826-1338 | Bushing, Plastic, Thermostat Shaft (Pkg of 25) |
| 14 | 810-0585 | Timer, 15-minute Mechanical Basket Lift |
| 15 | | Timer, 15-Minute Electrical Basket Lift |
| | 826-1552 | 100-120V |
| | 807-0401 | 208-240V |
| 16 | 950-0246 | Insulation, Double Electric Timer |
| 17 | 809-0093 | Screw, 6-32 X ³ / ₁₆ -inch Slotted Flat Head |
| 18 | 810-0276 | Adapter, Shaft End |
| 19 | 810-0999 | Shaft, Flexible |
| 20 | 809-0157 | Set Screw |
| 21 | 826-1361 | Stop Screw (Pkg of 25) |
| 22 | 809-0050 | Nut, 5-32 Hex |
| 23 | 900-2241 | Bracket, Thermostat |
| 24 | 900-2071 | Bracket, Thermostat Shaft Guide |
| 25 | 826-1371 | Screw, #8 X ½-inch Slotted Hex Washer Head (Pkg. of 25) |
| 26 | 910-4345 | Panel, Thermostat Control without Timers |
| 27 | 910-4344 | Panel, Thermostat Control with Electric or Mechanical Timers |
| * | 802-0336 | Label, Frymaster Logo |
| * | 806-4797 | Alarm, Open Drain (Buzzer) |

* Not illustrated.

NOTE: See Pages 2-16 and 2-17 for melt cycle timers.

CONTROLLER ASSEMBLIES (Other than Thermostat Controllers)

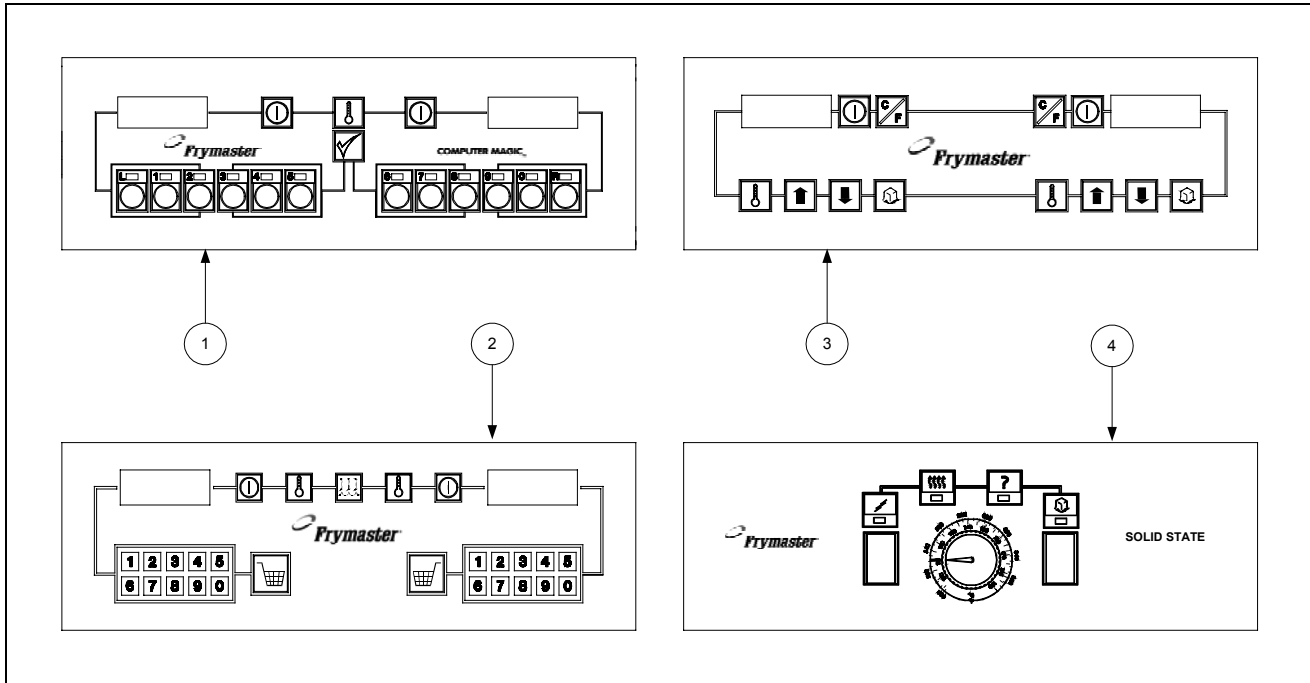

| ITEM | PART # | COMPONENT |
|------|------------|---|
| 1 | | Computer Magic III |
| | 106-1149SP | Built-In, Non-CE |
| | 106-1199SP | Built-In CE |
| | 106-1216 | Remote LP03 |
| | 106-1218 | Remote On-Hood |
| | 106-1230 | Remote In-Hood |
| 2 | 106-2079SP | Controller, Basket Lift Timer |
| 3 | | Controller, Digital |
| | 106-1501 | Non-CE |
| | 106-1505 | CE |
| 4 | 806-3559 | Controller, Solid State (<i>controller knob is 810-0387</i>) |
| * | 910-3690 | Panel, Blank Control (<i>for use on fryers with remote computers</i>) |
| * | 806-3660 | Sound Device (<i>for use w/all CM III Computers</i>) |
| * | 826-1379 | Screw, #10 X ½-inch Philips Truss Head (computer screws) (Pkg. of 10) |
| * | 826-1032SP | Kit, Control Panel Screws (2 screws and 2 screw retainers) |

* Not illustrated.

DOOR ASSEMBLY

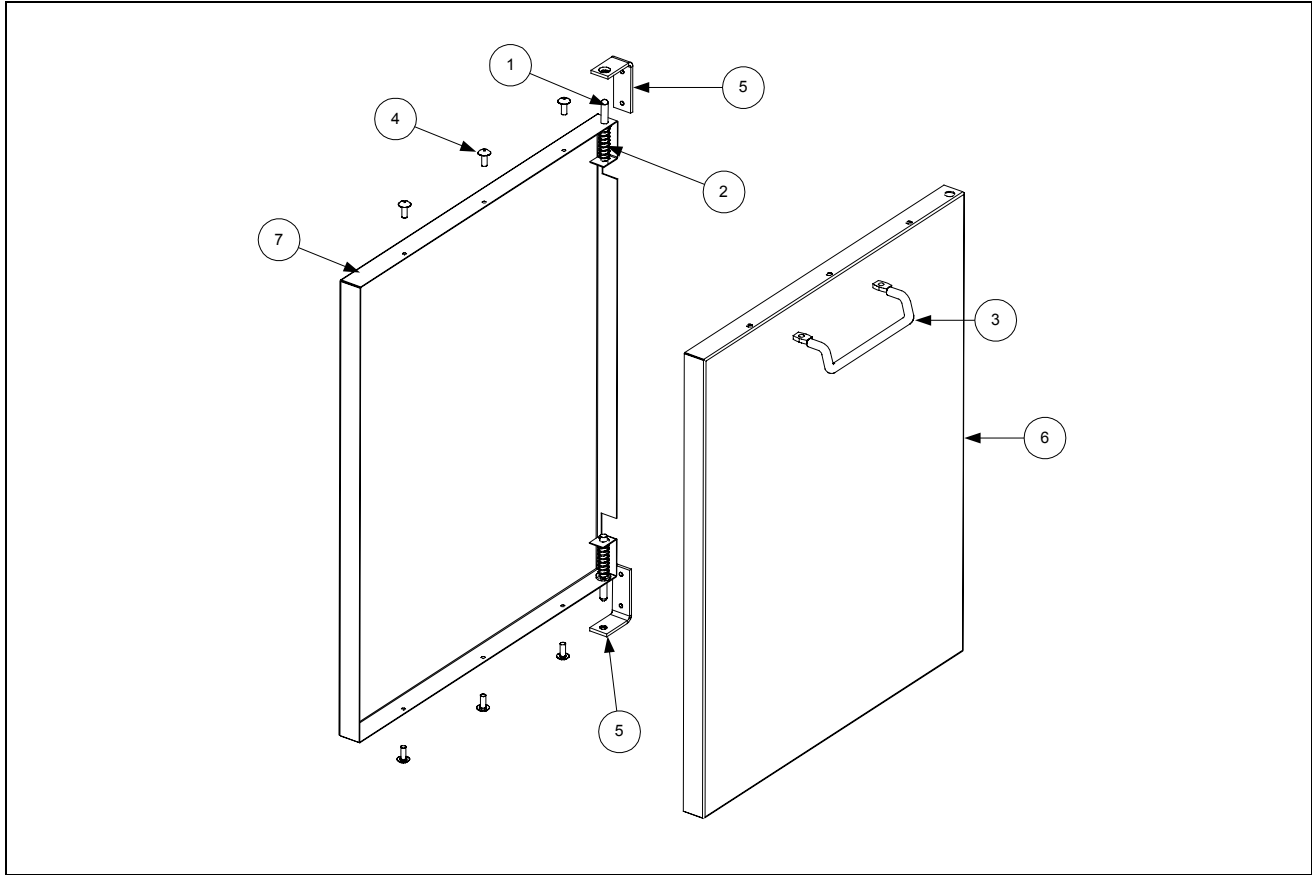

| ITEM | PART # | COMPONENT |
|------|------------|---|
| | 806-8320 | Door Assembly Complete, Enameled Steel (does not include Items 3 and 5) |
| | 806-6405SP | Door Assembly Complete, Stainless Steel (does not include Items 3 and 5) |
| 1 | 106-0554SP | Door Pin Assembly |
| 2 | 826-1343 | Spring, Door Pin |
| 3 | 810-1422 | Handle, Door, Wireform, Stainless Steel (<i>must be ordered separately</i>) |
| 4 | 826-1379 | Screw, #10 x 1/2" Phillips Head, Zinc Plated |
| 5 | 810-1508 | Hinge, Door, Universal (<i>must be ordered separately</i>) |
| 6 | 824-0616SP | Panel, Door, Outer |
| 7 | 900-4807 | Liner, Door |
| * | 810-1105 | Magnet, Door |

* Not illustrated.

DRAIN AND FILTRATION SYSTEM COMPONENTS

Drain System Components

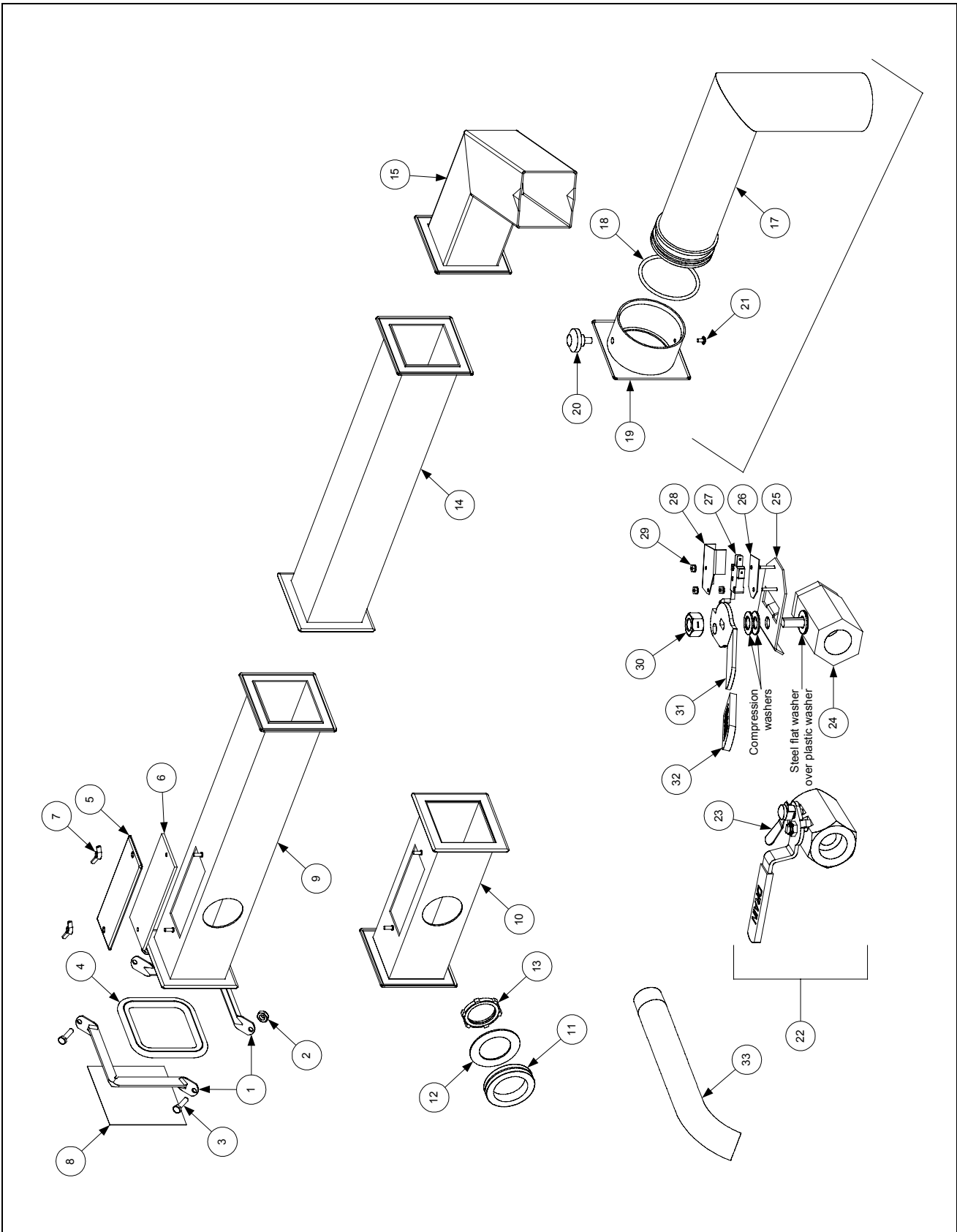

| Item | Part # | Component |
|------|------------|---|
| * | 826-0877 | Kit, Clamp Service (Contains 2 each of Items 1-3 and 1 of Item 4) |
| 1 | 810-0396 | Clamp Section (Requires 2 per connection) |
| 2 | 809-0071 | Nut, ¼–20 |
| 3 | 826-1375 | Screw, 10–32 X ¾ |
| 4 | 816-0032 | Seal (Connection Gasket) |
| 5 | 826-1348 | Cover, Clean-out (Pkg. of 5) |
| 6 | 816-0021 | Gasket, Clean-out |
| 7 | 826-1382 | Wing Nut, Clean-out Cover Retaining (Pkg. of 10) |
| 8 | 900-0757 | Cover, Drain End |
| 9 | 823-0717 | Full Vat, 15.5-inches Long |
| 10 | 823-0718 | End, Full Vat, 8.12-inches Long |
| * | 813-0284 | Nipple, 1-inch x ¾-inch (connects drain valve to drain tube) |
| 11 | | Grommet, Drain Tube |
| | 816-0092 | 1.50-inch I.D. |
| | 816-0091 | 1.75-inch I.D. (used on FM I units built prior to February 1990 only) |
| 12 | 826-1345 | Washer, Drain Tube Retaining (Pkg of 25) (1⅜-in. ID x 2 ³ / ₁₆ -in. OD) |
| 13 | 809-0347 | Nut, Drain Tube Retaining |
| 14 | 823-0731 | Extension, Spreader Cabinet, 15.5-inches Long |
| 15 | 823-0719 | Drain Outlet, Fixed |
| 16 | 806-4068 | Drain Outlet Assembly, Swivel |
| 17 | 823-1091 | Drain Tube, Swivel |
| 18 | 816-0083 | O-Ring, 2.5-inches ID |
| 19 | 823-1092 | Collar, Drain |
| 20 | 810-0388 | Knob, Clamping |
| 21 | 809-0115 | Screw, 10–32 |
| 22 | 810-1569 | Valve w/Handle, 1.25-inch Drain (for use on MJ45 units) |
| 23 | 810-1568 | Handle w/Lock, Drain Valve |
| 24 | 810-1020 | Valve, 1.25-inch Drain (for use on FM45 units)** |
| 25 | 806-8137 | Bracket, Drain Safety Switch |
| 26 | 816-0220 | Insulation, Drain Safety Switch |
| 27 | 807-2103 | Switch, Drain Safety |
| 28 | 900-2841 | Cover, Drain Safety Switch |
| 29 | 809-0237 | Nut, 4-40 Keps Hex |
| 30 | 809-0540 | Nut, ½-inch 2-Way Lock |
| 31 | 810-0820 | Handle, Drain Valve w/o Lock |
| 32 | 816-0211 | Sleeve, Drain Valve Handle |
| 33 | 812-1226SP | Extension, Drain |

* Not illustrated.

** For old-style valve with welded-on switch bracket, use [823-1363](#).

Filter Magic II Filter Pan Assemblies

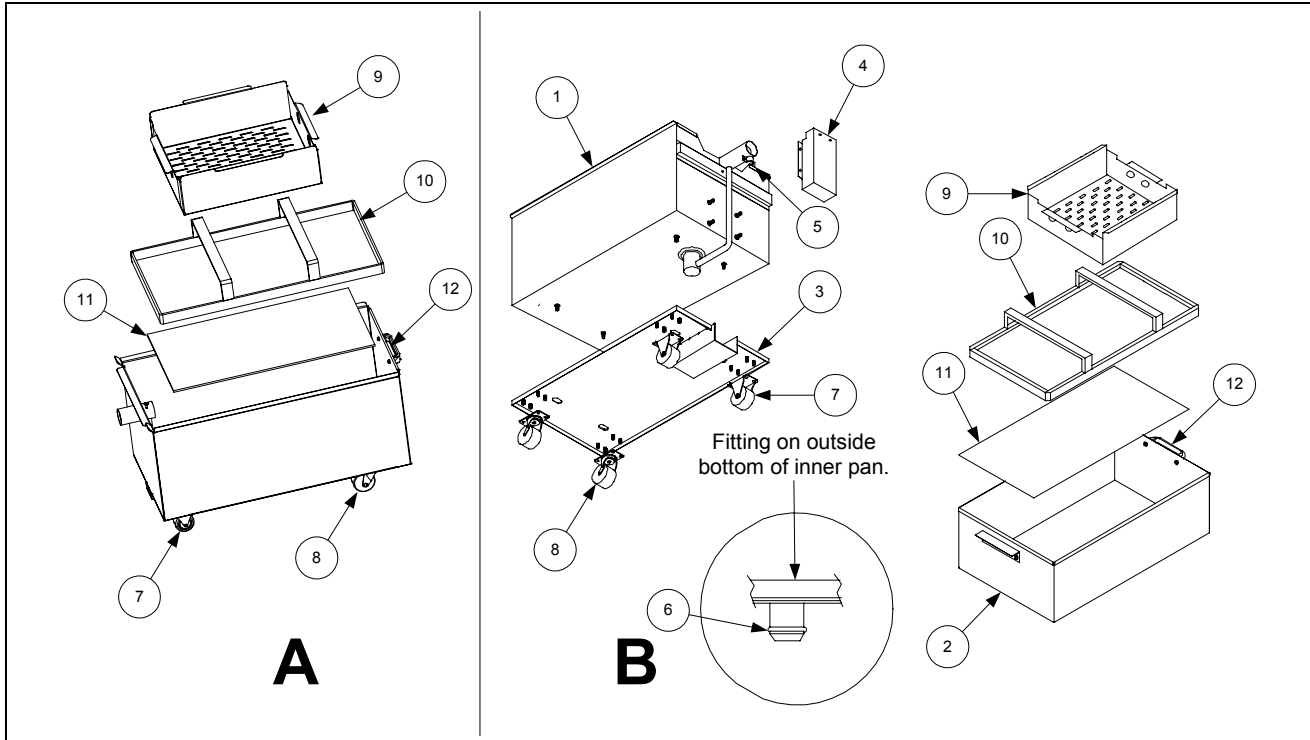

| Item | Part # | Component |
|--|------------|---|
| A | 806-9255SP | One-Piece Filter Pan Assembly (Items 7, 8, 10, 11, and 12) |
| | 823-2751SP | |
| B | 806-6093SP | Two-Piece Pan Assembly (Unique components are listed below.) |
| | 806-4338SP | |
| 1 | 823-1360SP | Outer Pan |
| | 806-5282SP | Inner Pan Assembly (Items 2, 6, 10, 11, and 12) |
| 2 | 823-1731SP | Inner Pan |
| 3 | 823-1361 | Base, Filter Pan Assembly |
| 4 | 824-0291 | Cover, Suction Tube |
| 5 | 910-1350 | Clamp, Suction Tube |
| 6 | 816-0117 | O-Ring, .609 OD |
| * | 806-4373 | Heater Strip Assembly |
| * | 811-0861 | Insulation, Foam (50-foot/15m roll) |
| * | 811-0746 | Tape, Aluminum Insulation (50-yard/46m roll) |
| Components Used in Both Designs | | |
| 7 | 810-0005 | Caster, Rigid |
| 8 | 810-0006 | Caster, Swivel |
| 9 | 824-0416 | Crumb Screen |
| 10 | 810-1406 | Hold Down Ring Assembly |
| 11 | 900-8827 | Sanagrid Filter Screen |
| 12 | 810-0180 | Handle, Filter Pan |
| * | 803-0170 | Paper, Filter (100 sheets) |
| * | 803-0002 | Powder, Filter (80 1-cup applications) |

* Not illustrated.

FRYPOT ASSEMBLIES AND COMPONENT PARTS

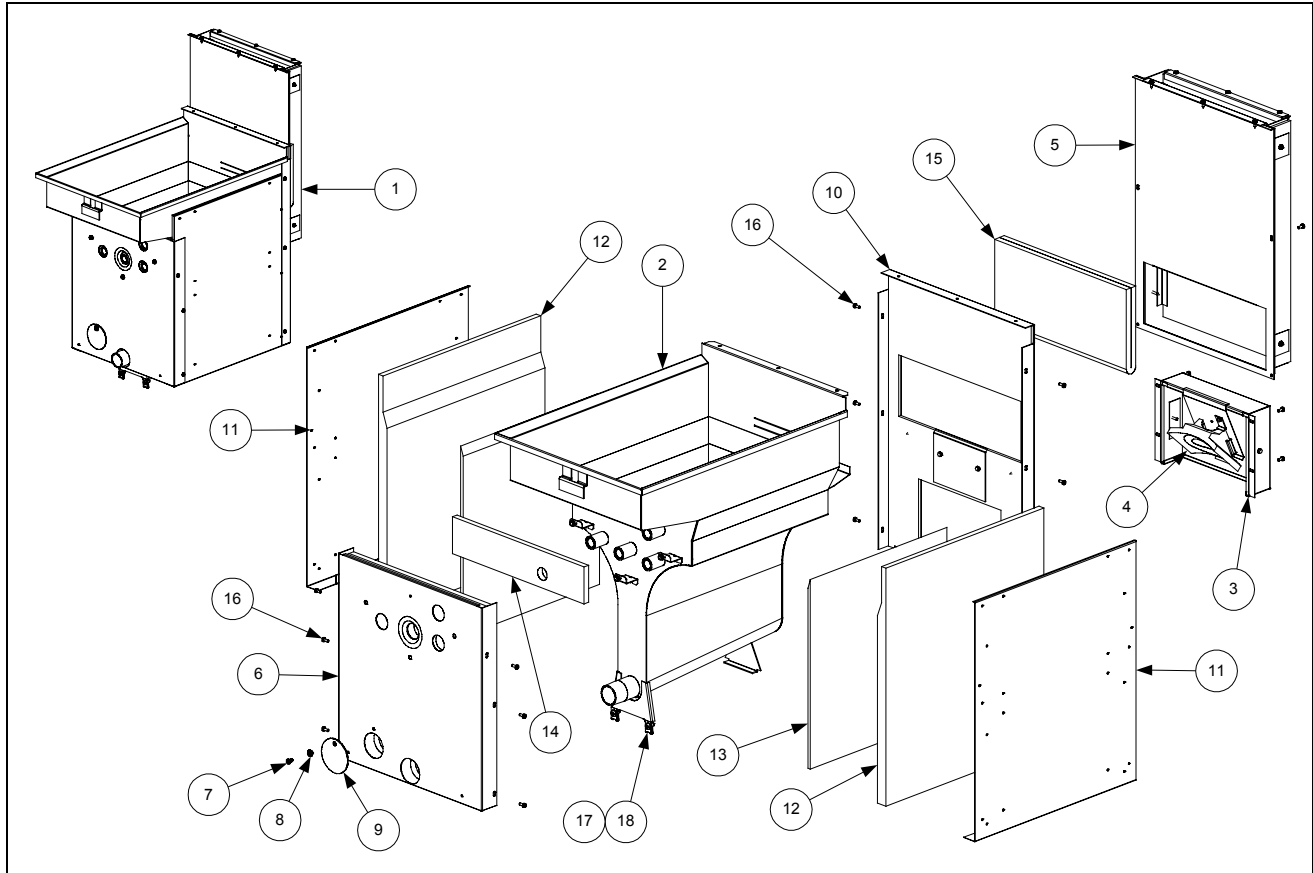

| ITEM | PART # | COMPONENT |
|------|------------|--|
| 1 | | Frypot Assemblies, Complete (Items 2, 3, 5, 6, and 10-18) |
| | 106-2549SP | Stainless Steel |
| | 806-3810SP | Cold Rolled Steel |
| 2 | | Frypot Assembly, without Insulation |
| | 823-3887SP | Stainless Steel (integral component of 106-2549SP) |
| | 823-0921SP | Cold Rolled Steel (integral component of 806-3810SP) |
| 3 | 806-5778SP | Flue Deflector Box Assembly, |
| 4 | 810-0424 | Deflector, Rear Burner (integral component of Item 3) |
| 5 | 806-5567SP | Flue Assembly |
| 6 | 806-1095SP | Front Baffle Assembly |
| 7 | 809-0409 | Screw, Pilot Light Cover (integral component of Item 6) |
| 8 | 810-0647 | Holder, Pilot Light Cover Screw (integral component of Item 6) |
| 9 | 900-1090 | Cover, Pilot Light (integral component of Item 6) |
| 10 | 806-5566SP | Rear Combustion Chamber Panel Assembly |
| 11 | 900-6441 | Panel, Combustion Chamber Side |
| 12 | 812-0249 | Insulation, Frypot Side, Outer Layer |
| 13 | 812-0248 | Insulation, Frypot Side, Inner Layer |
| 14 | 816-0602 | Insulation, Kaowool Blanket, ½ X 14 X 4 (trim to fit) |
| 15 | 812-0269 | Insulation, Kaowool Blanket, ½ x 14 x 14 |
| 16 | 826-1374 | Screw, #10 X ½-inch Washer Hex Head (Pkg. of 25) |
| 17 | 809-0173 | Clip, Tinnerman |
| 18 | 809-0170 | Screw, #14 X ¾-inch Slotted Pan Head |

OIL RETURN PLUMBING AND HANDLE COMPONENTS

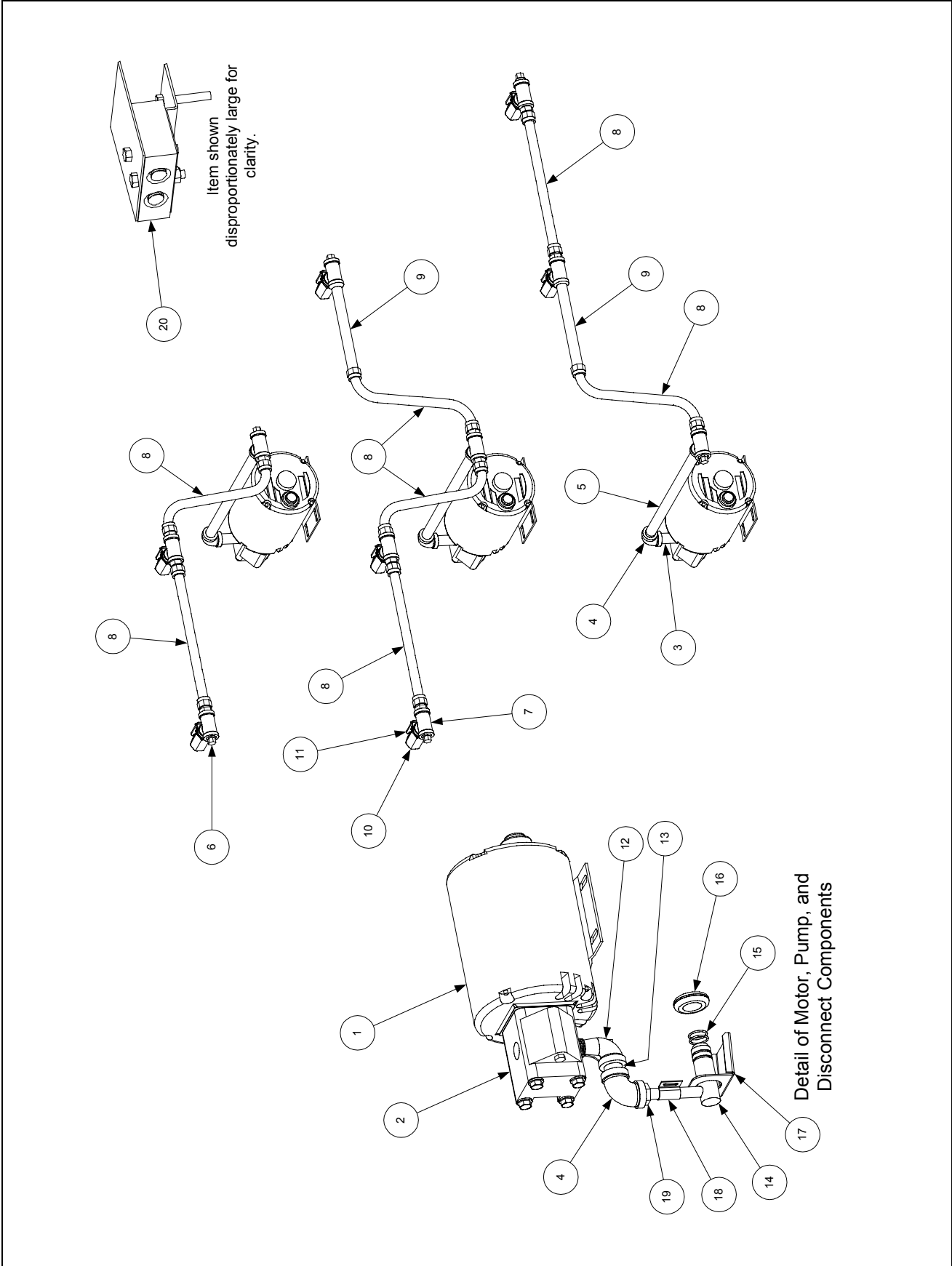

| ITEM | PART # | COMPONENT |
|------|------------|---|
| 1 | | Pump Motor |
| | 826-1712 | 100-120 VAC 50/60Hz (includes gasket 816-0093) |
| | 826-1756 | 208 VAC 50/60 Hz (includes gasket 816-0093) |
| | 826-1270 | 230-250 VAC 50/60 Hz (includes gasket 816-0093) |
| * | 806-6728SP | Pump Motor Wiring Assembly (used with above motor kits) |
| 2 | 826-1264 | Pump, 4 GPM (15 LPM) (includes gasket 816-0093 and mounting screws) |
| 3 | 813-0265 | Nipple, ½-inch x 2 ½-inch |
| 4 | 813-0062 | Elbow, ½-inch x 90° |
| 5 | 813-0368 | Nipple, ½-inch x 16-inch |
| 6 | 813-0156 | Pipe Plug, ½-inch |
| 7 | 813-0003 | Tee, ½-inch |
| 8 | 810-1057 | Flexline, 13-inch Oil Return (has female ends) |
| * | 810-1668 | Adapter, Male (used with Item 8; two required) |
| 9 | 813-0275 | Nipple, ½-inch x 9-inch |
| 10 | 810-0278 | Valve, ½-inch Ball |
| 11 | 902-0883 | Handle, Valve |
| 12 | 813-0165 | Elbow, ½-inch x 90° Street |
| 13 | 813-0022 | Nipple, ½-inch Close |
| 14 | 823-1356 | Disconnect Fitting |
| 15 | 826-1392 | O-Ring (pkg of 5) |
| 16 | 816-0102 | Grommet, Oil Diverter |
| 17 | 900-1472 | Diverter, Oil |
| 18 | 910-1627 | Bracket, Male Disconnect Support |
| 19 | 813-0330 | Bushing, ½-inch NPT to ½-inch Tube |
| 20 | 806-4694SP | Contacto Block Assembly |
| * | 813-0117 | Nipple, ½-inch x 3½-inch |
| * | 807-1600 | Thermal Switch, 100-120V Baldor Motors |
| * | 807-1601 | Thermal Switch, 200-250V Baldor Motors |
| * | 807-1598 | Thermal Switch, 100-120V Magnatek Motors |
| * | 807-1599 | Thermal Switch, 200-250V Magnatek Motors |
| * | 807-2016 | Wiring Harness, Controller to Filter |
| * | 807-1408 | Heater Strip, 120VAC 50W, 70-inch |
| * | 807-2050 | Heater Strip, 250VAC 90W, 70-inch |
| * | 811-0746 | Tape, Aluminum (2-inch x 50-yard (46m) roll) |

* Not illustrated

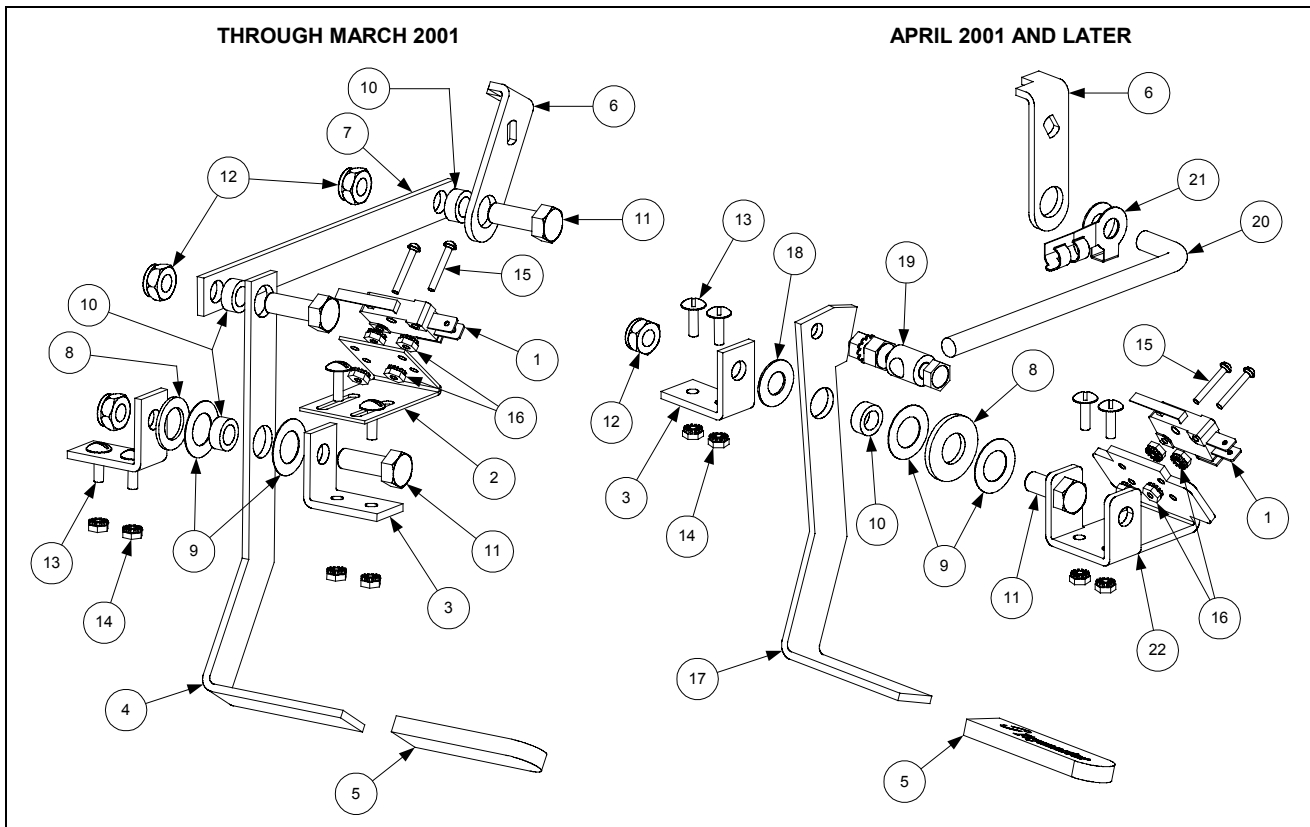

| ITEM | PART # | COMPONENT |
|------|----------|---|
| 1 | 807-2103 | Microswitch |
| 2 | 930-0839 | Bracket, Microswitch |
| 3 | 810-1999 | Bracket, Valve Handle |
| 4 | 900-1853 | Handle, Oil Return |
| 5 | 814-0047 | Sleeve, Handle |
| 6 | 900-0239 | Arm, Oil Return Valve |
| 7 | 920-0220 | Linkage, Oil Return Valve |
| 8 | 809-0200 | Washer, Flat |
| 9 | 826-1381 | Washer, Nylatron (Pkg of 10) |
| 10 | 810-0220 | Spacer, Tubular, .493 OD |
| 11 | 809-0142 | Screw, 5/16 – 24 x 3/4" Hex Head |
| 12 | 809-0056 | Nut, 5/16 – 24, Hex Head, Nylon Lock |
| 13 | 809-0104 | Screw, 4 – 32 x 1/2" Slotted Truss Head |
| 14 | 809-0247 | Nut, Keps Hex, 8 – 32 |
| 15 | 826-1359 | Screw, 4 – 40 x 3/4" Slotted Pan Head (Pkg of 25) |
| 16 | 826-1366 | Nut, Keps Hex, 4 – 40 (Pkg of 25) |
| 17 | 200-0938 | Handle, Oil Return |
| 18 | 810-1165 | Washer, Teflon 0.372 I.D. X 0.753 O.D. |
| 19 | 810-0285 | Swivel, Oil Return Linkage Rod |
| 20 | 200-1059 | Rod, Oil Return Linkage |
| 21 | 809-0601 | Clip, Clevis |
| 22 | 200-0821 | Bracket, Microswitch |

POWER SHOWER ASSEMBLY

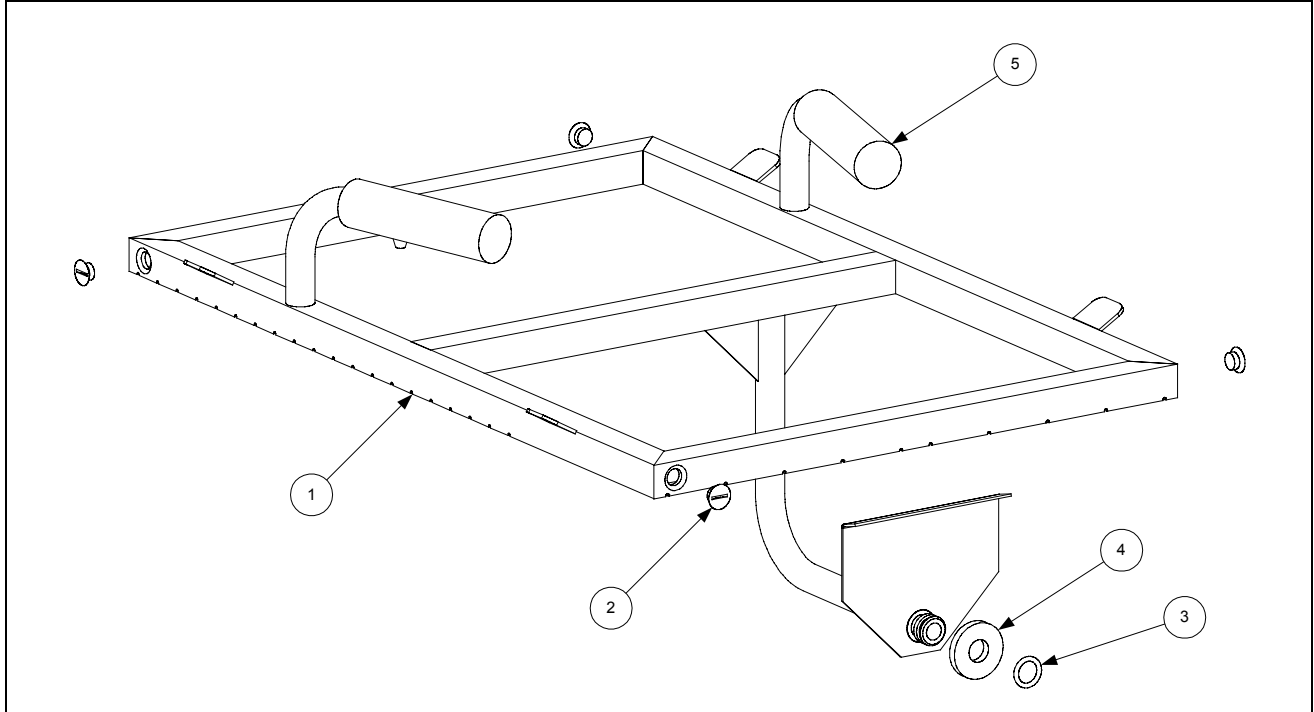

| ITEM | PART # | COMPONENT |
|------|------------|--|
| 1 | 806-4503SP | Power Shower Assembly, Complete |
| 2 | 809-0415 | Screw, Cleanout |
| 3 | 826-1344 | O-Ring (Pkg of 5) |
| 4 | 826-1390 | Seal (Gasket) (Pkg of 5) |
| 5 | 814-0001 | Grip, Handle |

TEMPERATURE PROBE, THERMOSTATS, AND RELATED COMPONENTS

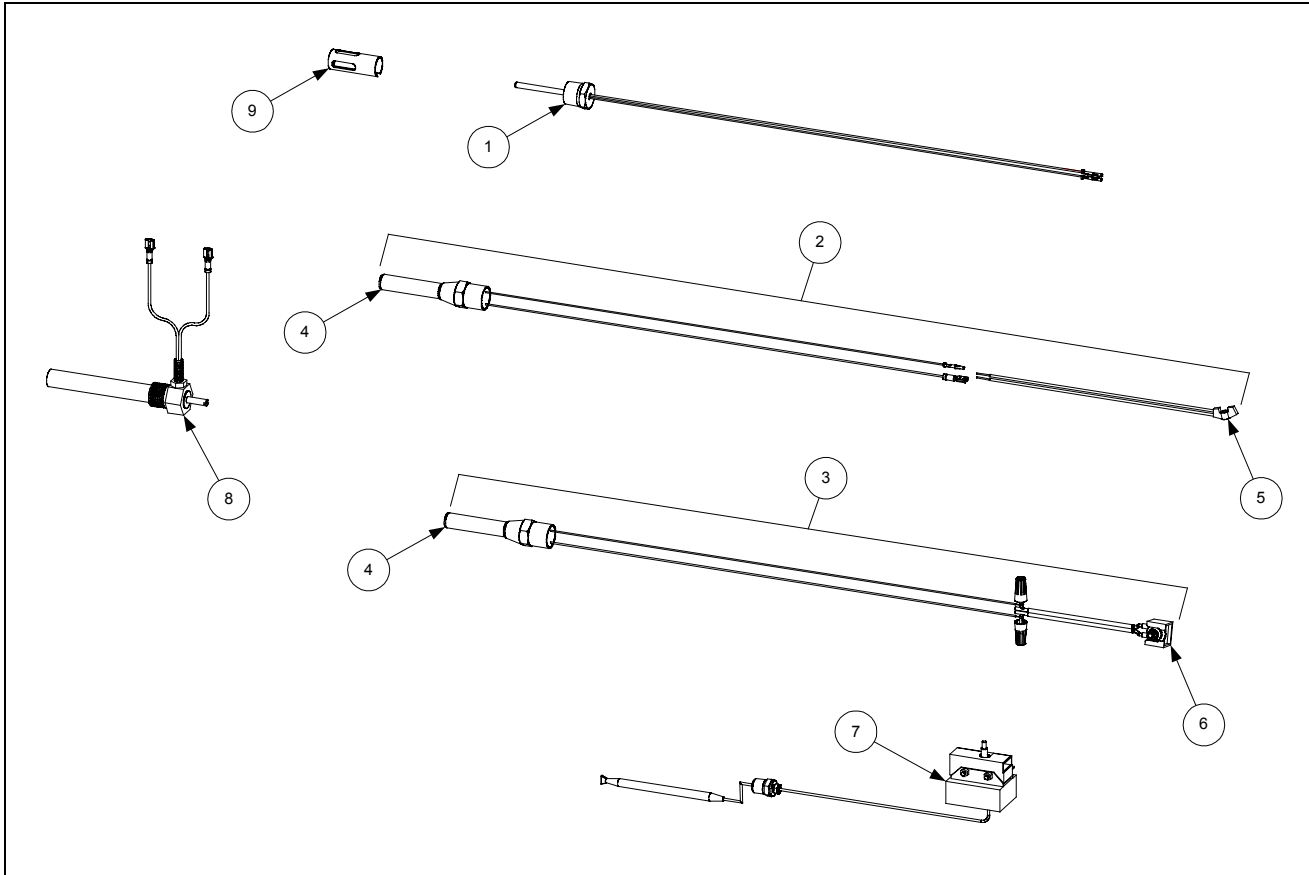

| ITEM | PART # | COMPONENT |
|------|----------------------------|---|
| 1 | 806-4206 | Temperature Probe, Minco |
| 2 | 826-1177 | Thermostat, Non-CE 425°F High-Limit (see NOTE 1) |
| 3 | 806-7550 | Thermostat, CE 218°C High-Limit (see NOTE 2) |
| 4 | 807-2274 | Thermostat, High Limit |
| 5 | 807-0280 | Adapter, High-Limit Thermostat (used only with Robertshaw gas valves) |
| 6 | 812-1256SP | Adapter Kit, High-Limit Thermostat to Honeywell Gas Valve |
| 7 | 806-3910 | Thermostat Assembly, Navy High-Limit (push-button reset) |
| 8 | 806-0183 | Thermostat Assembly, Operating |
| 9 | 210-0681 | Probe Guard |

NOTE 1: Kit [826-1177](#) (Item 2) contains high-limit thermostat [807-7224](#) (Item 4), Adapter [807-0280](#) (Item 5) and an assortment of connectors to allow it to be configured for use on several different Robertshaw valves.

NOTE 2: Assembly [806-7550](#) (Item 3) contains high-limit thermostat [807-2274](#) (Item 4) and screw-in gas valve adapter kit [812-1256SP](#) (Item 6) for connection to Honeywell gas valves.

WIRING ASSEMBLIES/HARNESSES AND REMOTE CABLE ASSEMBLIES

| Wiring Assemblies and Harnesses | |
|--|---|
| 806-2079SP | 100-120V Basket Lift Universal Motor (6-Pin female w/6 wires plus 1 separate wire) |
| 806-8555SP | 208-240V Modular Basket Lift Motor (6-Pin female w/6 wires plus 4 separate wires) |
| 106-1822SP | 100-120V Modular Basket Lift Motor (12-pin female w/5 wires) |
| 106-1804SP | 208-250V Modular Basket Lift Motor (12-pin female w/5 wires plus 3 separate wires) |
| 806-4798SP | Basket Lift Power, Non-CE (6-pin male w/6 wires; connects to 806-2079SP or 806-8555SP) |
| 806-6708SP | Basket Lift Power, CE (6-pin male plus 806-4798) |
| 807-3699 | Basket Lift Power, Non-CE/CE (12-pin male w/6 wires, connects to 106-1822SP or 106-1804SP) |
| 806-9777SP | Thermostat Control Universal (control panel-end connections) |
| 806-9778SP | Thermostat Control Universal (component shield-end connections) |
| 806-9779SP | Basket Lift Universal (control panel-end connections) |
| 806-9780SP | Basket Lift Universal (basket lift-end connections) |
| 806-9781SP | Wiring Bundle, Component Shield to Controller and Fryer Components (21-wire bundle) |
| 826-1560 | Kit, 45 Series Wiring (contains 806-9777SP through 806-9781SP) |
| 806-3549SP | Interface Board (interface board to fryer components; 12-pin male w/5 wires) |
| 806-6705SP | CE Non-Direct Wiring Power Supply (power cords joined in junction box) |
| 806-4214SP | Fryer to Fryer Drain Safety Switch (2-pin male w/two wires and 2-pin female w/two wires) |
| 806-4215SP | Fryer to Filter Drain Safety Switch (2-pin male w/two wires and 2-pin female w/two wires) |

NOTE: Assemblies [806-2079SP](#), [806-9777SP](#) through [806-9781SP](#) and kit [826-1560](#) are “universal” in nature. That is, they contain all wires and connectors necessary for all configurations of the application described. Consequently, there may be “extra” wires that are not needed in a particular configuration. Any extra wires should be removed when the assemblies are installed to preclude later confusion.

| Remote Computer/Controller to Interface Board Cables | |
|---|-------------------|
| Each of these assemblies has two 15-pin male connectors, and a 15-wire cable looped through a ferrite ring. Only the length of the cable varies. | |
| 806-2071 | 1.0 foot (30.5cm) |
| 806-3383 | 15.0 feet (4.6m) |
| 806-3388 | 20.0 feet (6.1m) |
| 806-4318 | 30.0 feet (9.1m) |

| Remote Computer/Controller Cable Assemblies | |
|---|------------------|
| Each of these assemblies has one 15-pin male connector, one 15-pin female connector, and a 15-wire cable. Only the length of the cable varies. | |
| 806-3528 | 7.5 feet (2.3m) |
| 806-3529 | 8.5 feet (2.6m) |
| 806-3530 | 10.5 feet (3.2m) |
| 806-3531 | 12.6 feet (3.8m) |

| Remote Computer/Controller Cable Assemblies w/Junction Box and Mounting Bracket | |
|---|-----------------------------|
| Each of these assemblies consists of a 4 X 4-inch junction box and mounting bracket assembly with one to four 15-pin female connectors and one to four 15-wire cables with a 15-pin male connector on the free end of each cable. | |
| 806-8350 | One Computer/Controller |
| 806-8349 | Two Computers/Controllers |
| 806-8348 | Three Computers/Controllers |
| 806-8351 | Four Computers/Controllers |

WIRING CONNECTORS, PIN TERMINALS, AND POWER CORDS

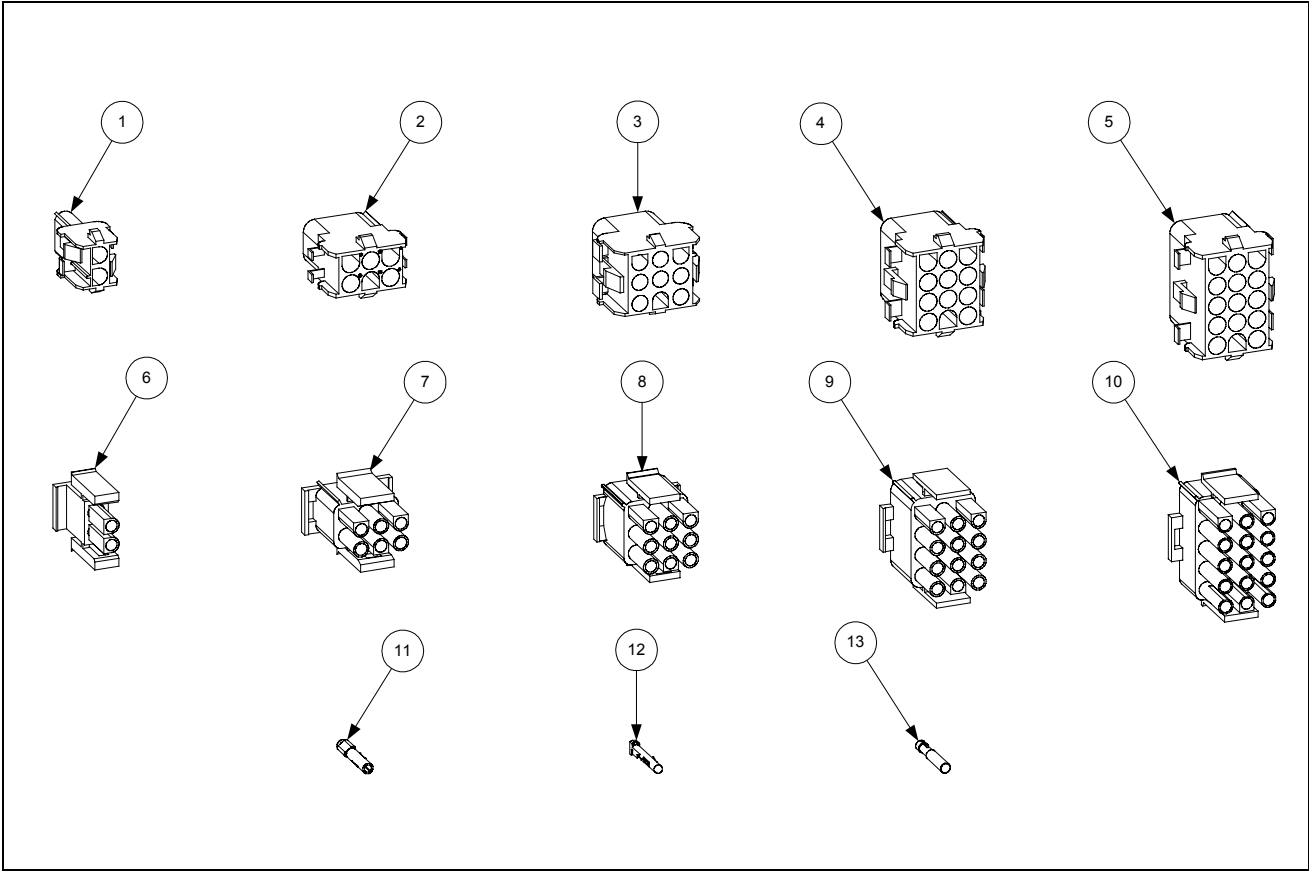

| ITEM | PART # | COMPONENT |
|--------------------|------------|--|
| Power Cords | | |
| * | 807-0154 | 100/120V-15A w/grounded plug |
| * | 806-6229SP | 100/208/240V-15A, w/o plug |
| * | 807-1685 | 100/208/240V-18A, w/o plug |
| Connectors | | |
| 1 | 807-1068 | 2-Pin Female |
| 2 | 807-0158 | 6-Pin Female |
| 3 | 807-0156 | 9-Pin Female |
| 5 | 807-0159 | 12-Pin Female |
| 5 | 807-0875 | 15-Pin Female |
| 6 | 807-1067 | 2-Pin Male |
| 7 | 807-0157 | 6-Pin Male |
| 8 | 807-0155 | 9-Pin Male |
| 9 | 807-0160 | 12-Pin Male |
| 10 | 807-0804 | 15-Pin Male |
| 11 | 826-1341 | Terminal, Female Split Pin (Pkg of 25) |
| 12 | 826-1342 | Terminal, Male Split Pin (Pkg of 25) |
| 13 | 807-2518 | Plug, Mate-N-Lock (Dummy Pin) |

* Not illustrated.

THIS PAGE INTENTIONALLY LEFT BLANK.



Frymaster[®]

Enodis[®]

One Company, Countless Solutions

Frymaster, L.L.C., 8700 Line Avenue, PO Box 51000, Shreveport, Louisiana 71135-1000
Shipping Address: 8700 Line Avenue, Shreveport, Louisiana 71106

TEL 1-318-865-1711

FAX (Parts) 1-318-688-2200

(Tech Support) 1-318-219-7135

PRINTED IN THE UNITED STATES

SERVICE HOTLINE
1-800-551-8633

819-5665
NOV 2003