

# Cleveland Range

## REPAIR MANUAL

### MODEL NO.

2DE24/2DE/2DLE/2DLLE

2DG24/2DG/2DLG/2DLLG 2DS24/2DS

2DSC24/2DSC

### Cleveland Range, Inc.

#### UNITED STATES

1333 East 179th St.

Cleveland, Ohio 44110

Phone: (216) 481-4900 • FAX: (216) 481-3782

#### CANADA

Garland Commercial Ranges • 1777 Kamato Rd.

Mississauga, Ontario CN L4W 1X4

Phone: (416) 624-0260 • FAX: (416) 624-0623

FCS-07

# Installation Instructions For Steam Generators, Steamers, Steamer/Kettles: Gas — Electric — Steam Coil

## Installation Instructions For All Models

- 1) These instructions must be retained by the owner / user for future reference. For installation only in noncombustible locations. Gas units are only to be installed in areas that have provisions for adequate air supply.
- 2) Position: For proper operation and drainage, steam generator must be level. It must be set near a floor drain. Attach 1 1/2" piping to all drain connections to carry exhaust steam away from the cabinet. Ends of drain lines must vent to atmosphere to avoid back pressure. Allow a MINIMUM of 6" clearance to the rear and sides of the equipment. The surrounding area must be free and clear of combustibles.
- 3) Install in accordance with local codes and/or the National Electric Code ANSI/NFPA No. 70-1984. Installation in Canada shall be in accordance with the Canadian Electric Code CSA Standard C22-1. A unit that is connected to electricity must be grounded. A wiring diagram is provided inside the relay box.
- 4) Connect supply lines for 140° — 160° hot water, and cold water, to the unit. Water pressure must be maintained between 35 and 60 psi. Locations and pressure data are shown on the connection drawing. Long hot water lines should be at least 1/2" IPS. Rush water supply lines thoroughly before connecting. Use water which is low in total solids content and low in gas content to prevent internal scaling, pitting and corrosion of the steam generator and carry-over of minerals into the steam. Water which is fit to drink can still contain highly detrimental impurities. Refer to Water Quality Requirements page.
- 5) Turn on water supply to steam generator. Water valve is inside of base.
- 6) Connect fuel supply

### FOR YOUR SAFETY

**Do not store or use gasoline or other flammable vapors and liquids in the vicinity of this or any other appliance.**

#### For Steam Coil Steam Generators —

- Connect steam supply: Location is shown on the connection drawing. Incoming steam pressure must be regulated between 35 and 45 psi (30 — 45 psi for pressure steamers). Install a strainer ahead of the regulating valve. Rush line thoroughly before connecting.
- Connect the outlet end of the steam coil to an inverted bucket trap. Fill trap with water before installing.
- Connect electricity if unit is equipped with electrical controls. Permanent 115V connection is required. Junction box location is shown on the connection drawing. Unit must be electrically grounded by the installer.

#### For Gas Fired Generators —

- Post, in a prominent location, instructions to be followed in the event the user smells gas. This information shall be obtained by consulting the local gas supplier.
- Connect gas: Location and pressure data are shown on the connection drawing. Installation shall be in accordance with local codes, or in the absence of local codes, with the National Fuel Gas Code, ANSI 2223.1 — 1984. Installation in Canada shall be in accordance with Installation Codes for Gas Burning Appliances and Equipment B1 49.1 and B149.2. Use a gas pipe joint compound, which is resistant to LP gas. Test all pipe joints for leaks with soap and water solution. Allow 12 inch clearance on right side of all Gas Fired Steam Generator models for servicing gas burners and for proper operation. This 12" clearance also provides adequate air openings into the combustion chamber. Never obstruct the flow of combustion and ventilation air. The appliance and its individual shutoff valve must be disconnected from the gas supply piping system during any pressure testing of that system at test pressures in excess of 1/2 psig (3-45 kPa). The appliance must be isolated from the gas supply piping system by closing its individual manual shutoff valve during any pressure testing of the gas supply piping system at test pressure equal to or less than 1/2 psig (3.45 kPa).
- Connect electricity if unit is equipped with electrical controls. Permanent 115V connection is required. Junction box location is shown on the connection drawing. Unit must be electrically grounded by the installer.
- Lighting and Shutdown Instructions: Flip electrical switch on. Open water valve. Open gas valve. Slightly depress and turn control knob to "off" for 5 minutes before lighting gas. Turn control knob to "pilot", depress it completely and light pilot burner. Continue to hold knob in for about 60 seconds, then release. Pilot burner is lighted through hole in panel at bottom of steam generator. Never leave panel off, as this will damage controls. Turn control knob to "on". Depress electrical "reset" switch for main burner ignition. Burners will not light without water in the steam generator. For main burner off, with pilot on, turn control knob to "pilot". For main and pilot burner off., slightly depress and turn control knob to "off". Flip electrical switch off.

#### For Electrical Steam Generators —

- Connect electric power Location is shown on the connection drawing. Provide connection as required by your unit. Electric supply must match power requirements specified on data plate attached to base. Wiring must be adequate to carry required current at rated voltage. A separate fused disconnect must be supplied and installed. Unit must be electrically grounded by the installer.

- 7) Turn on electricity at control circuit switch on steamer console. A red light glows when electricity is on. If water level is correct, steam generator will operate by pressing the "reset" button. Heaters will not work without water in the steam generator. This manual reset button must be pressed to start up the generator initially, and to restart the steam generator after every shut off, or power interruption. No attempt should be made to operate the equipment during a power failure.
- 8) Check to make sure that the water in the sight gauge glass automatically stays at about 2/3 full when the unit is started up.
- 9) When installation is complete and free of leaks, refer to Operating Procedures sheet

#### Instructions For Steam Generator Care

Protect your steam generator, prolong its life and preserve its performance by giving it the required daily attention, on a regular schedule. Follow servicing instructions for your steam generator which are printed on Data Sheet 260-LC in your Owner's Manual, and also on an adhesive label attached to the unit. To obtain an additional data sheet or label carrying servicing instructions, write to the Cleveland Range Company.

#### WARNING

**No work should be done on the steam generator while it is pressurized or hot. Service of the steam generator should only be performed by a trained and experienced service technician, thoroughly familiar with servicing steam generators. When maintenance or repairs are required, contact a local food service equipment service agency, or call the factory, or a factory representative, for the name and address of one in your area.**

### Steam Generator (Boiler) Safety

Rigid regulations govern the design and construction of a boiler- However, the responsibility for the safe and efficient operation of a boiler shifts to the owner/ user after the boiler leaves the factory.

A sound boiler, if improperly installed, or if improperly maintained, or if improperly repaired, will create a dangerous situation and may cause injury to personnel.

Most states, provinces and some cities have a boiler safety law. Many underwriters require that their clients' boilers comply with these boiler safety laws. These safety laws call for action by the boiler manufacturer and action by the boiler owner/user.

As a manufacturer, The Cleveland Range Company delivers steam generators built to the ASME Boiler Code, Section IV. which have been inspected by a National Board Inspector. Also, each Cleveland Range Company boiler is built to comply with the boiler safety law of the state to which it is sent.

#### Safe and Efficient Boiler Operation Depends on Proper Installation

Install (the boiler in compliance with following regulations, where they apply:

- The National Fuel Gas Code. ANSI 2223-1-1984
- Installation Codes for Gas Burning Appliances and Equipment B149.1 and B149.2
- The Cleveland Range Company Installation instructions.
- The National Electrical Code ANSI/NPPA No- 70-1984
- The local and municipal building code (plumbing and electrical)
- The state and city boiler laws
- The recommendations of the owner/user's under writers

The water for the boiler should be analyzed by a reputable boiler water specialist, to see if the quality will permit safe and efficient boiler operation. Water treatment is becoming increasingly necessary because the quality of water sources is deteriorating, although treatment will not be required in every case. A boiler will not operate properly for very long if the water causes boiler corrosion or scale. Even water which is safe to drink may be detrimental to a boiler. Refer to Water Quality Requirements page for details.

#### Safety Requires Periodic Inspection and Maintenance

Any leaks around the boiler's hand hole plate must be quickly stopped. Small leaks, if unchecked, cause corrosion and pitting on the boiler face. around the hand hole gasket making it unsealable. Application of undue stress on the parts that are used to seal the boiler's hand hole opening, in an attempt to seal an unsealable opening, by sledging the handle of the wrench, by increasing the leverage of the wrench by a length of pipe, or by other means, is dangerous because it may result in the breakage of pans, or injury. No attempts should be made to tighten up the nut on the retaining stud beyond the recommended 15 foot pounds of torque. When a repair affecting the safety of the boiler is necessary, call a National Board inspector for consultation and advice as to the best method of making the repair, so that the completed work will get his approval. Repairs to the boiler must conform to the applicable provisions in the ASME Code or the National Board Rules for Repairs. A boiler will last many years before it has to be retired from service. Periodic inspection will reveal the approaching retirement time. It is better to schedule a convenient replacement time than to wait for the boiler to fail. When a boiler older than 10 years is replaced the entire steam generator base assembly should be replaced for a number of reasons:

- Replacement pans become increasingly difficult to obtain for older controls.
- Dependable performance of the new controls can be assured for a longer time.
- The new steam generator including controls will comply with the latest industry and safety standards.

**CLEVELAND RANGE CO, 1333 EAST 179th ST., CLEVELAND OHIO 44110**

**1086 LITHO IN U.S.A.**

**Manufacturer reserves right of design improvement or modification, as warranted.**

## MODEL D CLEVELAND CONVECTION STEAMER OPERATING INSTRUCTIONS

**NOTE:** These instructions pertain to steamers equipped with self-contained steam generators (boilers). For steamers direct-connected to a remote (in-house) steam source, disregard those instructions which are directly and solely related to the self-contained steam generator.

- 1A. Open the cabinet base door and close the drain valve if it is open.
- B. Make sure the hot and cold water supply valves are open.
- C. Make sure that the steam tubes in the cooking compartments are in place and not loose.
2. Flip the toggle switch on front of the cabinet console to "ON". The red console light should then glow and the boiler will automatically begin filling with water (if it is not already full).
3. After approximately five minutes (after water appears in the sight gauge), depress the "START" reset button on the console. This will energize the electric heater elements or ignite the gas burners. This cannot be accomplished until the boiler is full of water.
4. In approximately 15 minutes you will notice the console's steam pressure gauge register 10-12 pounds. You can now preheat the cooking compartments. Preheating need only be done once before the day's cooking.
5. Compartments should be preheated before use and should be kept hot between loads. If a kettle and steamer are to be used at the same time, always heat the kettle unit first. When kettle contents begin to simmer, preheat the steamer compartments. When pressure returns to 10 pounds, cooking may begin in the steamer.
6. To preheat, close the compartment door with the palm of your hand on the latch. Turn the outer dial of the timer to 5 minutes and press its inner button. It will be several minutes before the arrow on the inner dial starts to move clockwise, toward the arrow on the outer dial. When the preheating is completed, the steam will automatically shut off and a buzzer will sound.
7. To cook, place the pan of food into the cooking compartment and repeat the operating procedure previously described (step #6) but set the timer for the length of time required, up to 30 minutes. The door may be opened for food inspection anytime during the cooking cycle, **BUT KEEP HANDS OUT OF THE COOKING COMPARTMENT TO PREVENT BURNS.**
8. If a cooking cycle longer than 30 minutes is desired, do not use the timer. Just depress the red "Manual" operation button to start the flow of steam. Remember, you must press the manual button again to shut the steam off. In either mode of operation, the red indicating light will glow when the compartment is in operation. In the manual mode, the timer can be used, but steam will continue to flow after the buzzer sounds.
9. At the end of each day's operation, flip the console toggle switch to the "Blowdown" position, open the door in the cabinet base and open the boiler drain valve, (red handle). This "Blowdown" drains the boiler and helps to keep it clean. When the boiler is empty, flip the console toggle switch to the "OFF" position, and close the boiler drain valve.
10. It is recommended that the boiler be refilled with water after the "Blowdown" is performed. This can be accomplished by flipping the toggle switch to the "ON" position for a period of five minutes and then returning the switch to the "OFF" position.

### TO PROLONG LIFE AND MINIMIZE SERVICE REQUIREMENTS

1. Blow down the steam generator daily.
2. A periodic boiler inspection must be performed by a qualified serviceman, to prolong its life and to minimize service calls.
3. At the end of each day's operation, wash the steam tubes, pan slides, drain screen covers, door gaskets, and compartment interiors with mild detergent and warm water. Thoroughly rinse with clean water. Rinse water should drain freely through the compartment drain openings. If it does not, the drain must be cleaned before using the steamer.
4. Once a week, flush each compartment drain with a food service equipment drain cleaner and a deliming solution.
5. Once every three months, shut off the water supply, (hot and cold), and clean the water line strainers.
6. Once a week, **remove** and **clean** the compartment steam tubes. Lubricate the steam tubes' rubber "O" rings with cooking oil prior to reinserting them into the compartments' back wall openings.
7. Steam tubes, drain screens, and pan slides are stainless steel, and can be washed safely in a mechanical dishwasher.
8. Always leave compartment doors ajar when not in use.

**CLEVELAND RANGE, INC., 1333 EAST 179th ST., CLEVELAND, OHIO 44110**  
Manufacturer reserves right of design improvement or modification, as warranted.

LITHO IN U.S.A. 0982

# The Cleveland Convection Steamer™

## TIMER SETTINGS

Timer settings are approximate due to the differences in food quality, age, shape and the degree of 'doneness' desired. It is not necessary to add water. Perforated pans are recommended. Starred items (\*) must be cooked in solid pans.

VEGETABLES	MINUTES		MINUTES
Asparagus, spears, frozen jumbo	6	<b>SEAFOOD</b>	
Beans, green, 2" long, frozen-loose pack or fresh	4	Clams, in hard shell	3
Beans, green, french cut, frozen-solid pack	5	Cod, filets, frozen	3
Broccoli, spears, frozen	2-3	Crab legs, king, frozen	4-6
Broccoli, spears, fresh trimmed	3	Halibut, 6-8 oz. portions, frozen	4-5
Broccoli, flowerettes, frozen	1-2	Lobster tails, 6-8 oz. portions, thawed	4-6
Broccoli, flowerettes, fresh	2-3	Red snapper, 8 oz. portions, frozen	4-5
Cabbage, fresh, slices or wedges	2-4	Salmon steaks, 8 oz. portions, frozen	7
Cabbage, fresh, 4-6 lb. head for cabbage rolls, steam, peel, repeat as necessary	2-4	Shrimp, large, 10 count per lb., frozen	4-6
Carrots, baby whole, fresh or frozen	10	<b>MEATS</b>	
Carrots, sliced, fresh	7-8	Prepare meats over a catch pan as juices can be used for gravy, beef stock and soups. The size of portion, thickness of cut, etc., should be considered when selecting a timer setting.	
Carrots, sliced or krinkle cut, frozen	3	Beef, 1 1/2" cubes	4-5 min/lb
Carrots, diced, frozen	2	Beef, 1 1/2" cubes, frozen	6 min/lb
Cauliflower, flowerettes, fresh	4-5	Beef, ground chuck, fresh or frozen	4 min/lb
Cauliflower, flowerettes, frozen	2-3	Beef, pot roast choice	8-12 min/lb
Celery, 1-1 1/2" diagonal cut	3	Beef, rump roast, choice, boned, rolled, tied	10-12 min/lb
Celery, diced, for stuffing	2	Beef, patties, chopped sirloin. 8 oz. portions, rare-2 min, medium-4 min, well done	6 min
Celery, minced	1/2	*Beef, corned, brisket	18-20 min/lb
Corn, yellow wh. kernel, frozen-loose pack	1	6-8 lb. cut with 1/2" water	
Corn on the cob, yellow, fresh	6	Chicken, 8 oz. pieces, frozen	18-20
Corn on the cob, white, fresh	4	Chicken, 1 1/2 lb. pieces, frozen	26-30
Corn on the cob, frozen	8-10	Liver, fresh or frozen	2-4
Eggplant, whole, fresh, to blanch	1	Meat loaf, fresh or frozen	5 min/lb
Mixed vegetables, frozen	2-3	Weiners, frozen or thawed	2
Mushrooms, whole, fresh, 1/2" diameter	3	<b>PASTA</b>	
Onions, diced or sliced	2-3	Place pasta into 2 1/2" deep perforated pan and nest into a solid 2 1/2" deep pan. Cover pasta with cold water, stir at least once during steaming.	
Peas, green, frozen	2	Lasagna noodles	12
Potatoes, whole, 8 oz., with skin. no foil	30-35	Macaroni, shells or elbow	12
Potato, sweet, whole 8 oz., with skin.	30-35	Noodles, 1/2" wide	10
Spinach, leaf, fresh or thawed	1 1/2	Spaghetti, vermicelli	8
Spinach, frozen 3 lb. block	15-17	Spaghetti, regular	10
Squash acorn, cut into halves, no seeds	15	<b>PREPARED ENTREES</b>	
Squash, cooked, frozen 4 lb. block	18-20	Cabbage rolls, stuffed, frozen, full size pan. steam, then cover with hot tomato sauce and serve	20
Zucchini, diced, fresh or frozen	2-4	Casserole dishes such as beef stew etc.. Full size pan. Frozen	25-30
<b>FRUIT</b>		Lasagna, pre-cooked, refrigerated, full size pan, 4" sq. servings	25-30
Apples, cored, blanch for peeling	1	<b>EGGS</b>	
Apricots, dried	10	Hardcooked in shell for egg salad or potato salad	10
Grapefruit, blanch for peeling	1	Soft cooked, in shell	3
Oranges, blanch for peeling	1	Soft yolk, for caesar salad	5
Peaches, blanch for peeling	1		
Pineapple, whole, for cutting	1-2		
Prunes, dried	10		
<b>DEHYDRATED FOODS</b>			
*Potatoes, random sliced, use 5 cups cold water per lb.	12		
*Rice, long grain, use 4 cups cold water per lb.	17		

**CLEVELAND RANGE, INC., 1333 EAST 179th ST., CLEVELAND, OHIO 44110**

Manufacturer reserves right of design improvement or modification, as warranted.

## CONVECTION STEAMER MECHANICAL COMPONENTS

Model "D" with Blue Control Panel and 30-Minute Timer

Date of Manufacture: July 1976 through December 1985

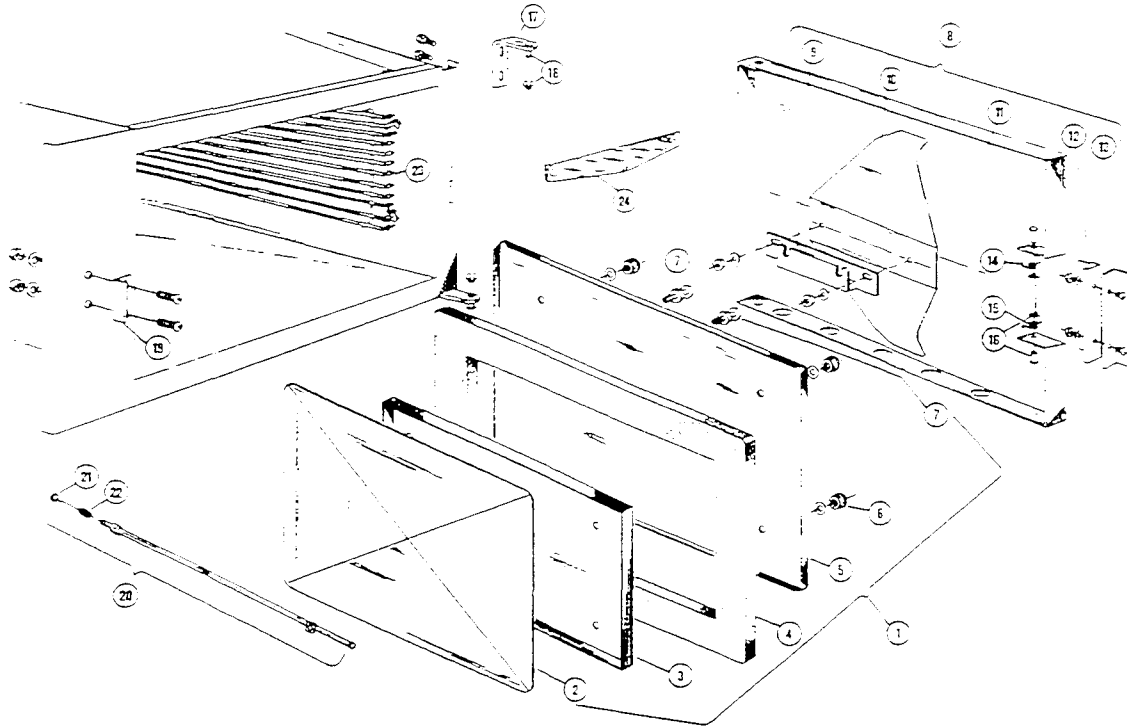

REFERENCE NUMBER	PART NUMBER	DESCRIPTION
1	42063	Inner Door Assembly
2	44098	Gasket Retainer Plate
3	66556	Inner Gasket Retainer Plate
4	07138	Gasket
5	04171	Inner Door
6	14667	1/4-20 Knurled Finger Nut (4 required)
7	19923	Inner Door Mounting Stud (2 required)
8	40818*	Outer Door Assembly
9	52488	Outer Door Mounting Bracket
10	69635	Door Spring
11	44057	Outer Door Weldment
12	40746	Door Latch
13	58177	Door Handle
14	19577	Upper Door Spring
15	19578	Lower Door Spring
16	40817	Latch Pin & Retainer (2 required)
17	02414	Hinge Bracket (upper or lower)
18	40816	Hinge Pin & Retainer (2 required)
19	53061	Door Catch
20	40299	Steam Tube Assembly
21	15201	Tube "O" Ring
22	19574	Tube Spring
23	41423	Slide Rack
24	40417	Drain Cover Screen

\*Also available as part number 44056—

Replacement Outer Door Assembly with Latch and Handle, less Door Spring and Mounting Bracket. (Door latch # 08116 is no longer available. If this door latch breaks, the entire outer door must be replaced with #44055, using the door spring and mounting bracket from the original door. In addition, the door catch must be replaced with the replacement catch #53061, using the screws, nuts, and lockwashers from the original door catch.)

CLEVELAND RANGE, INC., 1333 EAST 179th ST., CLEVELAND, OHIO 44110  
 Manufacturer reserves right of design improvement or modification, as warranted. 1286

LITHO IN U.S.A.

# CONVECTION DOOR IDENTIFICATION

## INNER DOORS

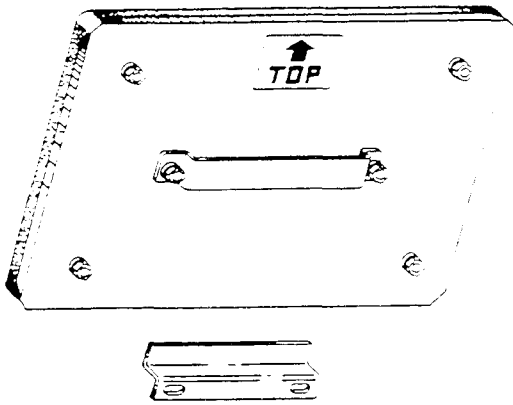

No longer available.

Must convert unit to latest style by replacing both inner and outer doors.

(See Below & Drawing 261-DS-R2).

SEE DWG 261-DS-R2

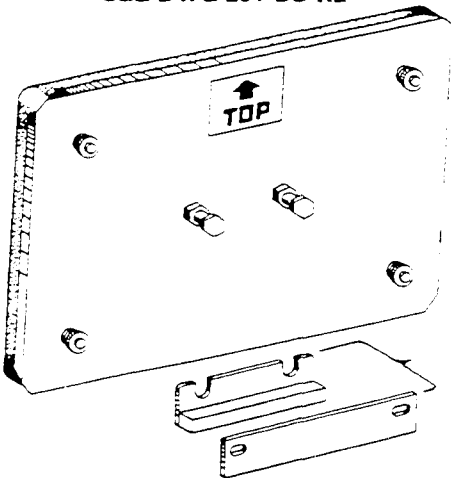

Latest Inner Door Assembly, part number 42063 (currently available)

## OUTER DOORS

Style A

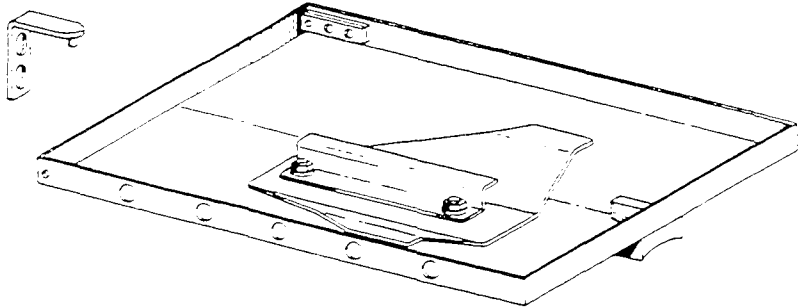

No longer available.

Must convert unit to latest style by replacing both inner and outer doors.

(See Drawing 261-DS-R2)

Style B

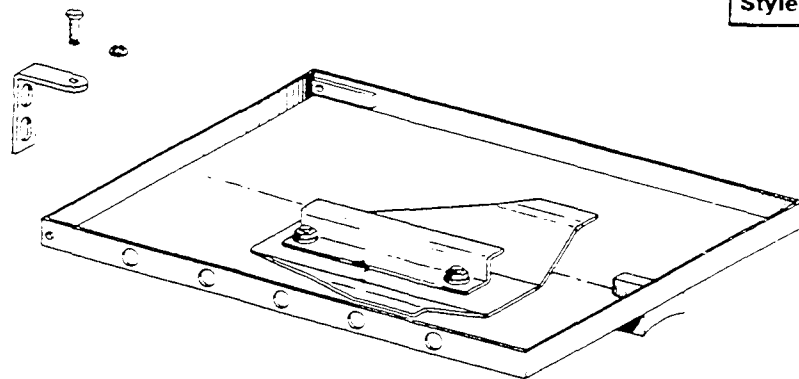

No longer available.

Must convert unit to latest style by replacing both inner and outer doors.

(See Drawing 261-DS-R2)

Style C

SEE DWG 261-DS-R2

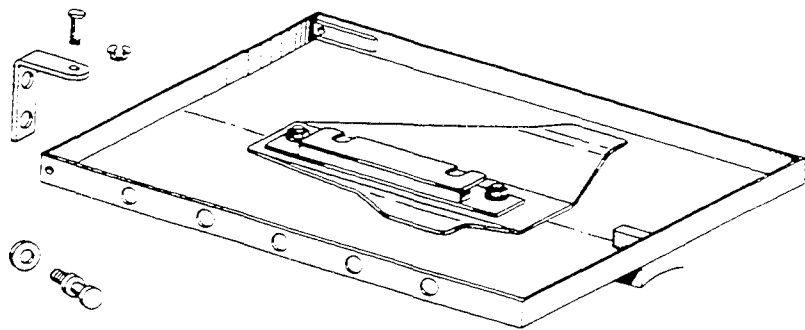

No longer available.

Must convert unit to latest style by replacing the outer door and the door catch.

(See Drawing 261-DS-R2)

# CONVECTION STEAMER ELECTRICAL COMPONENTS

Model "D" with Blue Control Panel and 30-Minute Timer Date of

Manufacture: July 1976 thru December 1985

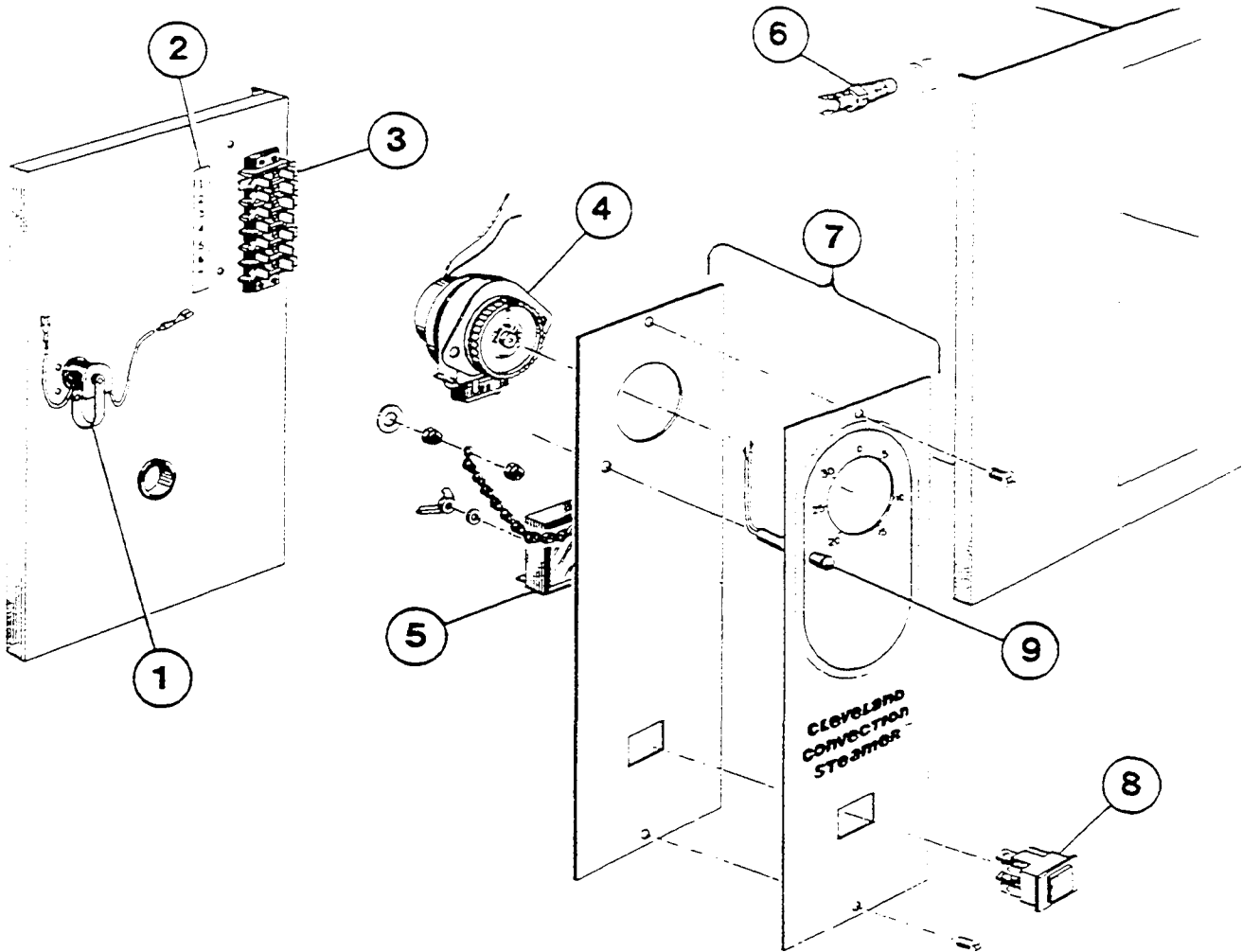

REFERENCE NUMBER	PART NUMBER	DESCRIPTION
1	41350	Buzzer
2	14860	Terminal Block Label
3	02195	Terminal Block
4	43904	Timer
	19996	Micro-Switch (2 required)
5	20477	Timer, Solid State
6	19972	Thermal Switch
7	100635	Instrument Panel
8	19978	Illuminated Push Button Switch (Timer By-Pass)
9	12159	Neon Indicator Light
10	19285	Instrument Panel Screw

CLEVELAND RANGE CO., 1333 EAST 179th ST., CLEVELAND, OHIO 44110  
 Manufacturer reserves right of design improvement or modification, as warranted.



# CONVECTION STEAMER PIPING COMPONENTS

Model "D" with Blue Control Panel and 30-Minute Timer  
Date of Manufacture: January 1975 thru December 1985

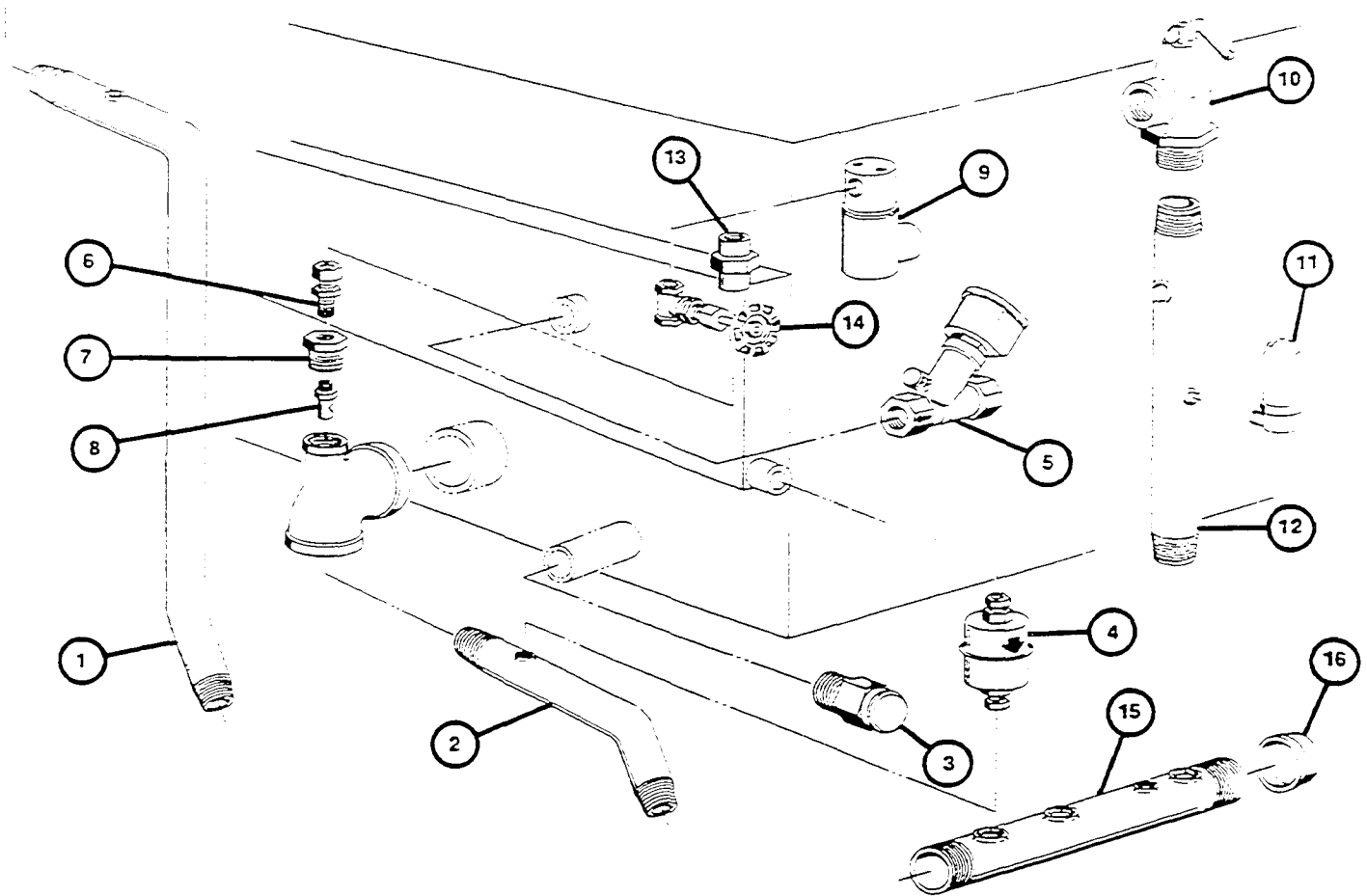

REFERENCE	NUMBER	DESCRIPTION
1	63172	Drain Pipe, Upper Compartment Only
2	63171	Drain Pipe, Lower Compartment Only
3	22202*	Safety Relief Valve — NO LONGER REQUIRED - NOT AVAILABLE
4	20559	Thermostatic Trap — Compact
5	22201	3/8" Solenoid Valve — Steam
6	06216	1/4" Tube x 1/4" Pipe Connector
7	02549	Condenser Bushing
8	14498	Nozzle — Steam Condenser (K-5)
9	22215	1/4" Solenoid Valve — Water
10	22131	3/4" Safety Valve — 15 psi
11	22140	Air Vent — NOT REQUIRED ON DIRECT CONNECT UNITS
12	63170	Steam Manifold
13	15455	Row Controller (regulator), 0.5 gpm
14	22099**	Needle Valve
15	63162	Drain Manifold
16	03058	1-1/2" Cap

\*Used until November 1982, then deleted from the steamer. \*\*Optional after November 4, 1982.

**CLEVELAND RANGE CO., 1333 EAST 179th ST., CLEVELAND, OHIO 44110**  
Manufacturer reserves right of design improvement or modification, as warranted.

## CONVECTION STEAMER PARTS — ELECTRICAL

### STYLE A — DATE OF MANUFACTURE: JANUARY 1975 TO JUNE 1975

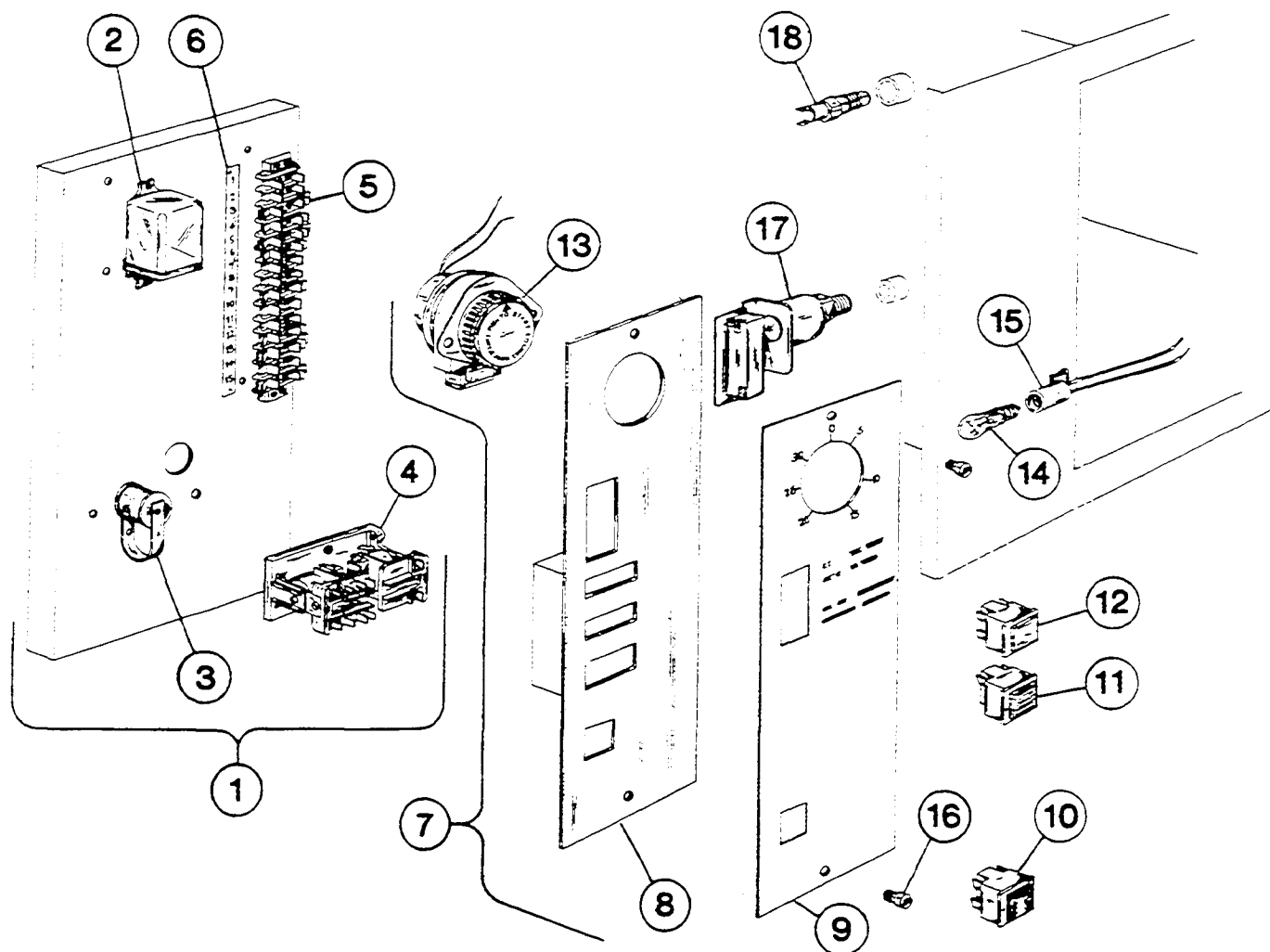

REFERENCE NUMBER	PART NUMBER	DESCRIPTION
1	47007	Divider Panel Electrical Assembly
2	03511	Relay, By-Pass
3	41350	Buzzer
4	03510	Relay, Safety Circuit
5	02195	Terminal Block - 7 Pole (2 required)
6	14860	Terminal Block Label
7	47006	Instrument Panel Assembly (Not Available)
8	42236	Instrument Panel Sub-Assembly (Not Available)
9	14858	Instrument Panel Label (Not Available)
10	19975	Switch Illuminated Push Button (Red, 3 Terminal)
11	19974	Switch Illuminated Push Button (Amber, 3 Terminal)
12	19973	Switch Illuminated Push Button (White, 4 Terminal)
13	43904	Timer Assembly
14	02482	Bulb, 3W-120V
15	41351	Bulb Socket
16	19285	Instrument Panel Screw
17	19971	Pressure Switch
18	19972	Thermal Switch

CLEVELAND RANGE, INC., 1333 EAST 179th ST., CLEVELAND, OHIO 44110  
 Manufacturer reserves right of design improvement or modification, as warranted.

LITHO IN U.S.A.

**CONVECTION STEAMER PARTS — ELECTRICAL**  
**STYLE B — DATE OF MANUFACTURE: JULY 1975 TO JUNE 1976**

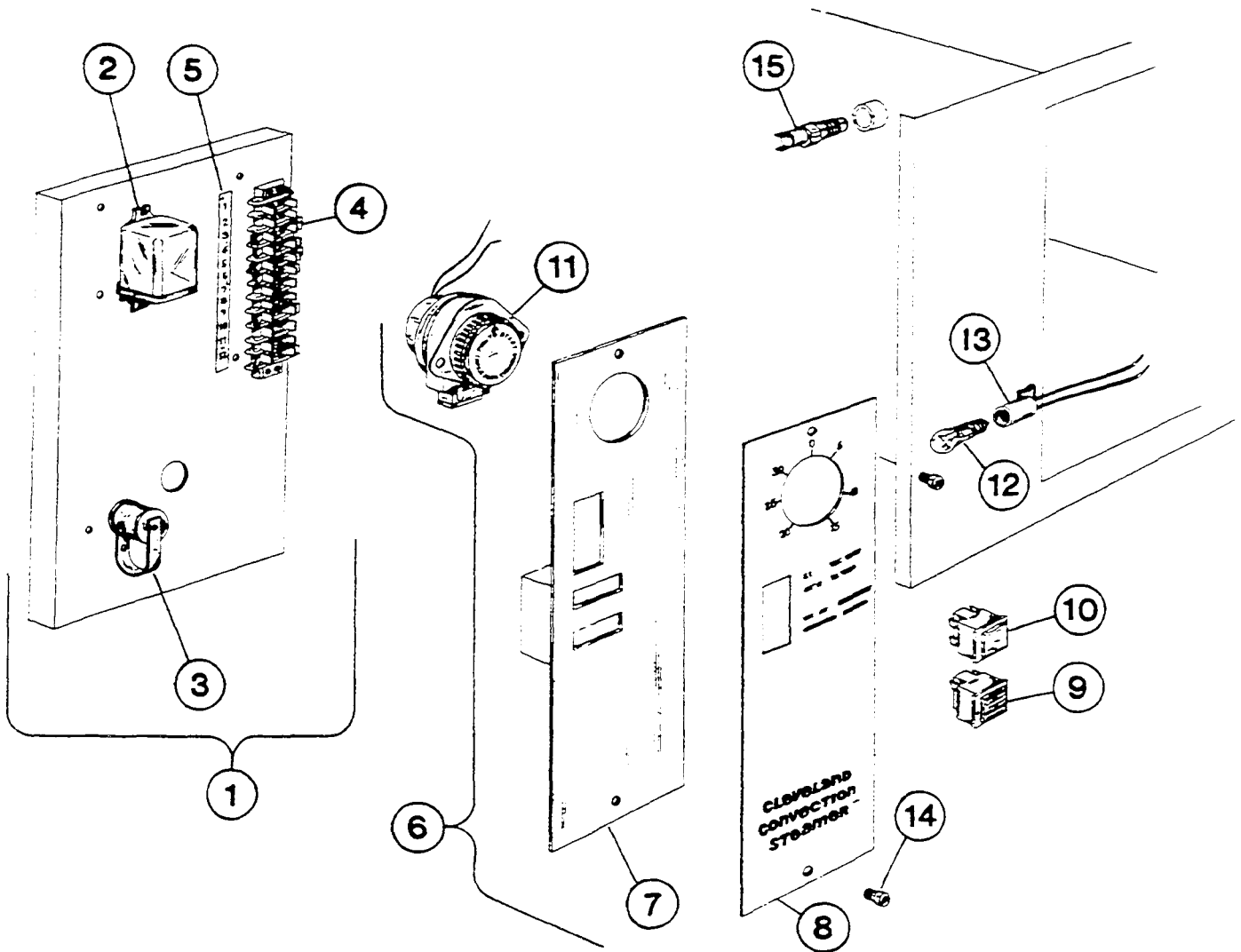

REFERENCE NUMBER	PART NUMBER	DESCRIPTION
1	47007	Divider Panel Electrical Assembly
2	03511	Relay, By-Pass
3	41350	Buzzer
4	02195	Terminal Block - 7 Pole (2 required)
5	14860	Terminal Block Label
6	47006	Instrument Panel Assembly (Not Available)
7	42236	Instrument Panel Sub-Assembly (Not Available)
8	14858	Instrument Panel Label (Not Available)
9	19974	Switch Illuminated Push Button (Amber, 3 Terminal)
10	19973	Switch Illuminated Push Button (White, 4 Terminal)
11	43904	Timer Assembly
12	02482	Bulb, 3W-120V
13	41351	Bulb Socket
14	19285	Instrument Panel Screw
15	19972	Thermal Switch

## MODEL "D" CONVECTION STEAMER — (Since 7/76) COOKING COMPARTMENTS ELECTRICAL OPERATING SEQUENCE

### TIMER CONTROL (Follows Operating Instructions)

- Timer's outer dial pointer is set to desired time
- Disc in center of timer is depressed:
  - Timer switches No. 1 and No. 2: normally open contacts are closed and normally closed contacts open.
  - Red indicator light comes on.
  - Steam solenoid and water solenoid valves open.
  - Steam activates the thermostatic switch (between terminals 5 and 6 on the terminal block), starting timer motor.
- When the timer runs down to zero:
  - Timer switches No. 1 and No. 2: normally closed contacts close and normally open contacts open.
  - Red indicator light goes off.
  - Steam solenoid and water solenoid valves close.
  - Buzzer sounds for 3 seconds, then goes off.

### MANUAL OPERATION

- Red Manual (timer bypass) switch is depressed.
  - Switch lights up.
  - Steam solenoid and water solenoid valves open.
- Unit will operate until the switch is depressed again,

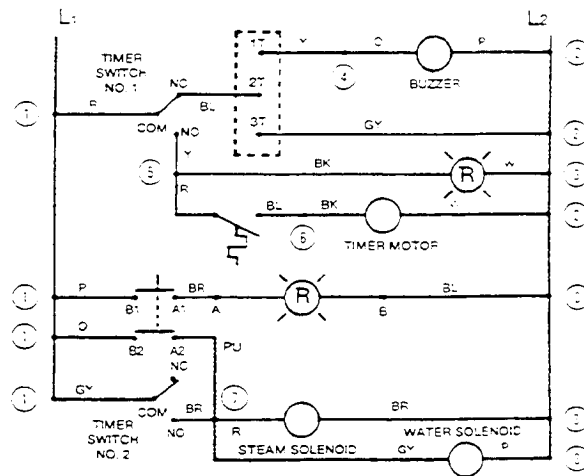

NUMBERS CIRCLED ARE TERMINAL BLOCK CONNECTIONS

causing its light to go off. (No buzzer will sound).

- The timer can be used during manual operation. It will "time-out" and sound the buzzer, but it will not shut off the steam.

## MODEL "D" CONVECTION STEAMER — (7/75-6/76) COOKING COMPARTMENT'S ELECTRICAL OPERATING SEQUENCE

### TIMER CONTROL (Follows Operating Instructions)

- Timer's outer dial pointer is set to desired time.
- Disc in center of timer is depressed:
  - Timer switches No. 1 and No. 2: normally open contacts are closed and normally closed contacts open.
- "ON-OFF" switch is depressed, energizing circuit
  - "ON-OFF" switch lights up.
  - Backlighted yellow legend "COOKING" appears.
  - Steam solenoid and water solenoid valves open.
  - Steam activates and the thermostatic switch (between terminals 7 and 8 on terminal block) starting timer motor.
- When the timer runs down to zero:
  - Timer switches No. 1 and No. 2: normally closed contacts close and normally open contacts open.
  - Backlighted yellow legend "COOKING" disappears.
  - Steam solenoid and water solenoid valves close.
  - Buzzer sounds.
  - Backlighted green legend "COOKED" appears.
- "ON-OFF" switch is depressed, deenergizing buzzer and circuit.

### BYPASS CONTROL

- "BYPASS" switch and "ON-OFF" switch are depressed:
  - "BYPASS" switch and "ON-OFF" switch light up.
  - Bypass relay is energized, closing contacts between terminals 7-5.

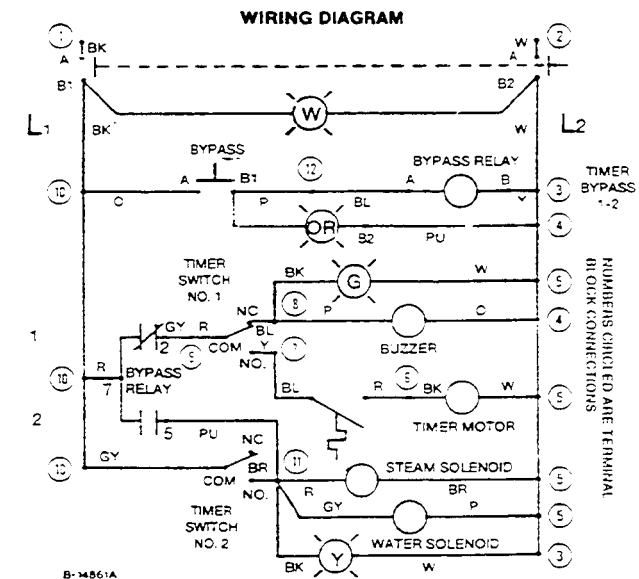

- Backlighted yellow legend "COOKING" appears.
  - Steam solenoid and water solenoid valves open.
- Unit will operate until the "BYPASS" switch and "ON-OFF" switch are depressed again.

CLEVELAND RANGE, INC., 1333 EAST 179th ST., CLEVELAND, OHIO 44110

LITHO IN U.S.A.

Manufacturer reserves right of design improvement or modification, as warranted.

# MODEL "D" CONVECTION STEAMER — (1/75-6/75) COOKING COMPARTMENT'S ELECTRICAL OPERATING SEQUENCE

## TIMER CONTROL (Follows Operating Instructions)

1. Timer's outer dial pointer is set to desired time.
2. Disc in center of timer is depressed.
  - a. Timer switches No. 1 and No. 2: normally open contacts are closed and normally closed contacts open.
3. "ON-OFF" switch is depressed, energizing circuit
  - a. "ON-OFF" switch lights up.
  - b. Back lighted yellow legend "COOKING" appears.
  - c. Steam solenoid and water solenoid valves open.
  - d. Steam activates thermostatic switch (between terminals 7 and 8 on terminal block) starting timer motor.
4. When the timer runs down to zero:
  - a. Timer switches No. 1 and No- 2: normally closed contacts close and normally open contacts open.
  - b. Backlighted yellow legend "COOKING" disappears.
  - c. Steam solenoid and water solenoid valves close.
  - d. Buzzer sounds.
  - e. Backlighted green legend "COOKED" appears.
5. "ON-OFF" switch is depressed, deenergizing buzzer and circuit

## BYPASS CONTROL

1. "BYPASS" switch and "ON-OFF" switch are depressed:
  - a. "BYPASS" switch and "ON-OFF" switch light up.
  - b. Bypass relay is energized, closing contacts between terminals 7-5.
  - c. Backlighted yellow legend "COOKING" appears.
  - d. Steam solenoid and water solenoid valves open.
2. Unit will operate until the "BYPASS" switch and "ON-OFF" switch are depressed again.

## SAFETY CIRCUIT

Assume unit in operation — either the timer control or the bypass control.

1. The cooking chamber is suddenly subjected to a pressure higher than atmospheric:
  - a. Pressure switch (between terminal 15 of terminal block and latch terminal A) is activated, energizing latch relay.
  - b. Latch relay opens contact between terminals 1 and 7 and closes contact between terminals 6 and 9.
  - c. Power to the operating circuits is cut off.
  - d. The momentary switch lights up red.
  - e. Backlighted red legend "CLEAN-RESTART" appears.
2. When the condition that caused the over pressurization is corrected, push the momentary switch in:
  - a. The backlighted red legend "CLEAN-RESTART" and red illuminated switch will go off.
  - b. The release relay is energized closing contact between terminal 1 and 7 and opening contact between terminal 6 and 9.
3. The unit now returns to normal operations.

WIRING DIAGRAM

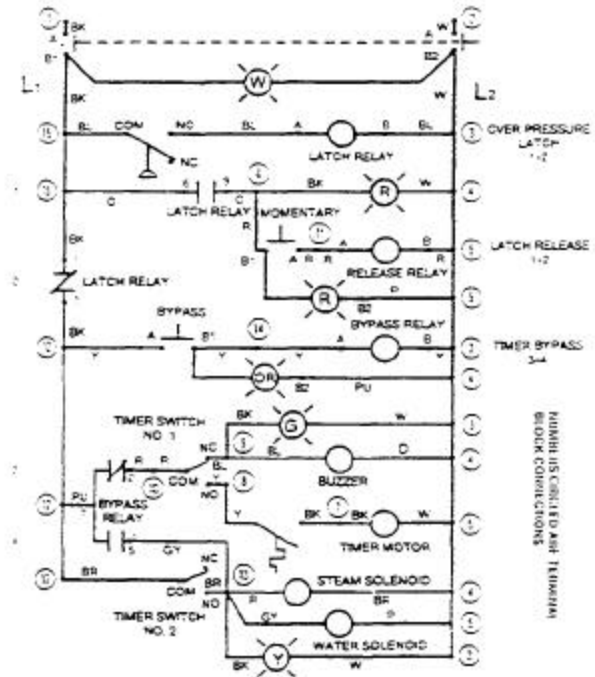

CLEVELAND RANGE, INC., 1333 EAST 179th ST., CLEVELAND, OHIO 44110

LITHO IN U.S.A.

Manufacturer reserves right of design improvement or modification, as warranted.

## MAINTENANCE INSTRUCTIONS FOR STEAM GENERATORS (EXCEPT THOSE EQUIPPED WITH TWO PROBES)

**WARNING: Steam under pressure may cause serious injury and bodily harm when it is accidentally or carelessly released. Therefore, service of the steam generator should only be performed by trained and experienced personnel, thoroughly familiar with servicing steam generators.**

**CAUTION: Never work on the steam generator when it is hot or pressurized.**

Every steam generator shipped is equipped with at least one corrosion resistor (cathodic). The larger capacity steam generators will have two corrosion resistors.

The hand hole plate and gasket on your steam generator stops the escape of steam through the hand hole opening during operation.

- 1) Turn off all energy sources to steam generator. Drain steam generator.
- 2) Remove hand hole cover plate from steam generator.
- 3) Hang corrosion resistor from the right side of the front stay rod, away from the probes. Clean scale and rust off a portion of the stay rod, so the hanger will rest on the bright, bare metal.
- 4) Reinstall the hand hole plate, along with a new gasket.

The hand hole plate should be cleaned and examined every time it is removed. If the hand hole plate is chipped or cracked, or over three years old, install a new one. Because continuous use and possible abuse cause metal fatigue which weakens the hand hole plate, a new one should be installed at least every three years.

**CAUTION: Never tighten the hand hole plate nut when steam generator is in use, hot, or otherwise pressurized. Never tighten nut over 15 foot-pound torque. Overtightening may cause uneven stress which may result in the weakening and possible breakage of the plate.**

Replace the gasket whenever the hand hole plate is removed or replaced. Keep a spare gasket on hand at all times.

Replace the gasket at least once a year, or sooner if it is cracked, torn or hardened.

Leakage of water past the hand hole plate should not be allowed to continue, as this will cause pitting of the metal in contact with the gasket.

5) After re-installing the hand hole plate, close the steam generator drain valve. Turn on energy sources.

6) Start up and operate steam generator long enough to observe that it is operating properly.

The corrosion resistor is sacrificial and must be replaced at regular intervals just before it is entirely consumed.

Frequency of replacement can only be established by a regular inspection for how much of the protector remains and whether scaling or pitting has begun. Scaling indicates a very hard water condition. Pitting indicates an excess acid condition. In either case, more protectors or more frequent replacement of them is necessary. The best way to reduce servicing time and to assure long generator life, is to provide feed water that is low in solids content and low in gas content. Water that is fit to drink can still be high in impurities that are highly detrimental to a steam generator. Consult a water treatment specialist in your area for recommendations concerning steam generator feed water treatment. Under average conditions, the corrosion resistor provides about six months of service. An average condition would meet each of the following tests:

- 1) Less than 8 hours of steam generation a day.
- 2) One generator blowdown every day.
- 3) Moderately hard water. Less than 85 ppm.
- 4) Water containing less than 60 ppm Total Dissolved Solids.

Distribution of hard water in the U.S. is shown on map, right. Areas shown in black have hardest water, while relatively soft water is found in white areas. Shaded area require supplemental feed water treatment to remove or to reduce the hardness.

This map is a general representation and exceptions do exist. Consult a local water treatment specialist for a water sample test.

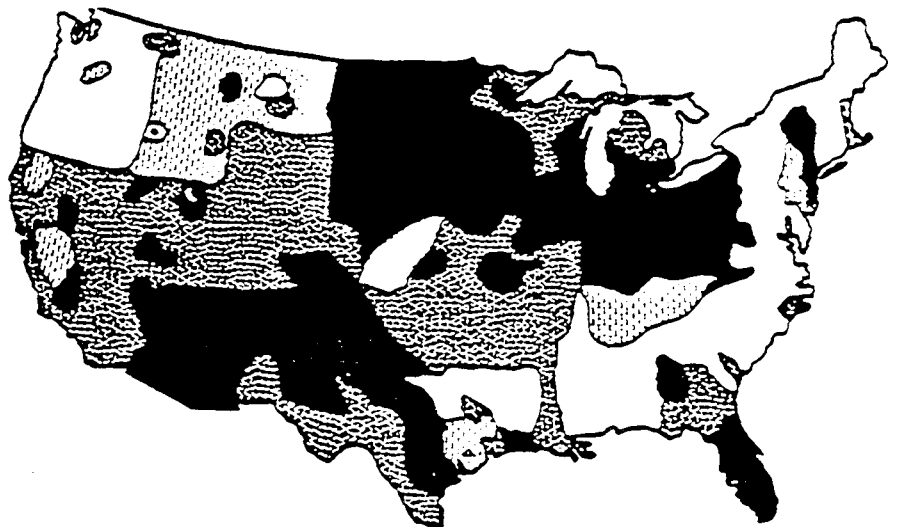
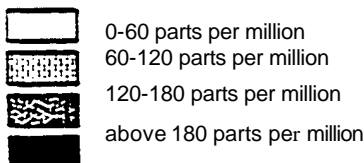

CLEVELAND RANGE CO., 1333 EAST 179th ST., CLEVELAND, OHIO 44110

LITHO IN U.S.A.

Manufacturer reserves right of design improvement or modification, as warranted.

# STEAM GENERATOR (BOILER) IDENTIFICATION

**ELECTRIC SIDE HEATER  
SCREW TYPE**

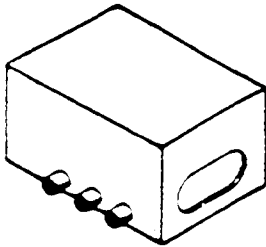

(NOT AVAILABLE)

**GAS 210 M**

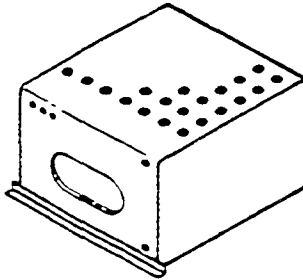

**PART NO. 403091 • (43833)**

**GAS 100-150 M**

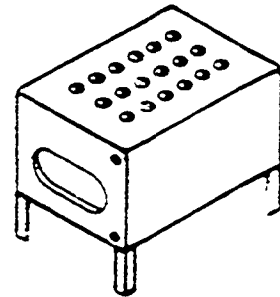

**PART NO. 40306 • (43826)**

**ELECTRIC 24-36-48 KW**

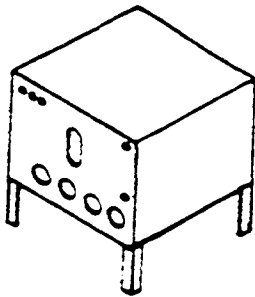

**PART NO. 43936 • (43938)**

**GAS 210 M**

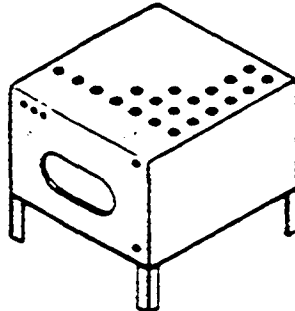

**PART NO. 40718 • (43832)**

**GAS 100-150 M**

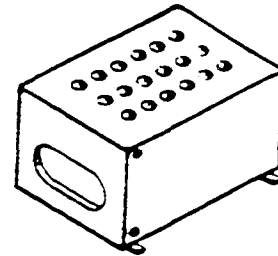

**PART NO. 403071 • (43828)**

**STEAMCOIL**

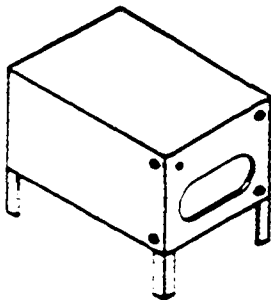

**PART NO. 43700 • (43782)**

**GAS 160-200 M**

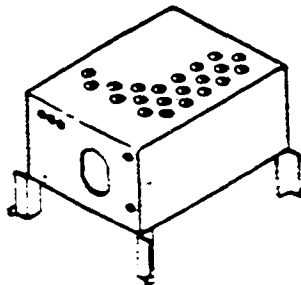

**PART NO. 43926 • (40298)**

**GAS 250-300 M**

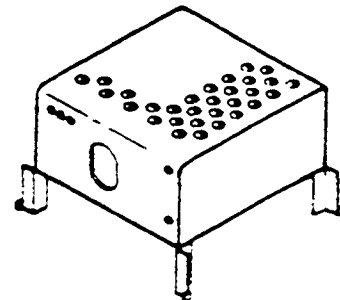

**PART NO. 43927 • (40297)**

## SERVICE NOTE

The above drawings showing the sight gauge location and method of mounting are for assisting in determining the proper part number for replacement generators. When ordering please provide both the proper part number and the equipment's serial number.



## START-UP MAINTENANCE PROCEDURES — STEAM GENERATOR

**IMPORTANT: The instructions must be followed in order to prevent premature failure of the steam generator.**

### START-UP:

- 1) Open the cabinet base door and close the drain valve if it is open. (Red handle lever marked "blowdown".)
- 2) Flip the toggle switch on front of the cabinet console to "ON" (up position). The red console light should then glow and water will automatically begin filling the generator.
- 3) When the water level in the sight gauge glass (on the generator) reaches — approximately 2/3 full (after approximately five minutes). Depress the "ON" reset button on the console. This will energize the electric heater elements or ignite the gas burner. If the sight gauge glass shows no stabilized water level, i.e., the gauge glass is completely empty or completely fitted, have the generator serviced.
- 4) In approximately ten minutes you will notice the steam pressure gauge, on the console, register the steam pressure contained inside the generator.
- 5) Cooking may now begin. Refer to "Cooking" and "Operating Procedure" data sheets for specific instructions.

### MAINTENANCE:

- 1) At the end of each day's operation, while the generator is pressurized, flip the console toggle switch to the "Blowdown" position, open the door in the cabinet base and open the generator's drain valve, (red handle). This "Blowdown" procedure drains the water out of the generator and helps to prevent lime scale formation. When the generator is empty, flip the console toggle switch to the "OFF" position and close the generator's drain valve. It is recommended that the generator be refilled with water after the "Blowdown" is performed. This can be accomplished by flipping the toggle switch to the "ON" position for a period of five minutes and then returning the switch to the "OFF" position.

**CAUTION: Service on the generator should only be performed by a trained and experienced service technician, thoroughly familiar with servicing steam generators. No work should be done on the steam generator while it is pressurized or hot. Be sure all energy source are shut off before the start of any work.**

2) Even though the "Blowdown" is performed faithfully each day. It will still be necessary to periodically inspect the inside of the generator. The generator's hand hole plate should be removed at regular intervals, so that it and the inside can be inspected. The hand hole plate should be cleaned and examined each time it is removed. If the hand hole plate is chipped or cracked, or over three years old. Install a new one. Replace the corrosion resistor(s) if necessary, and chemically descale the generator if it is coated with lime scale. A new hand hole gasket should always be installed.

3) It will be necessary to periodically have scale accumulations removed from the inside of the steam generator, by a qualified service technician. Generator descaling instructions are provided on a separate data sheet. Failure to periodically remove scale from the inside of the generator will result in greatly reduced generator life.

4) Every steam generator is equipped with at least one corrosion resistor to reduce generator shell corrosion and scaling. This corrosion resistor is sacrificial and must be replaced at regular intervals just before it is entirely consumed. In areas where the water is very hard, the feedwater must also be treated to remove the harmful mineral content.

Refer to separate data sheets for corrosion resistor servicing instructions, feedwater treatment information, and hand hole plate servicing instructions.

5) Check the safety valve once a week while steam generator is pressurized. Test by pulling safety valve extension wire. Valve must open freely and snap closed when released. If it does not or if it drips constantly, a new safety valve is needed.

6) If the steam generator is to be left idle for three months or more, it should be drained and dried out and the hand hole plate left off.

7) Water level in the sight gauge normally should be about 2/3 full. This level is maintained automatically.

Refer to separate data sheet for either mechanical or water fill servicing instructions.

8) If gas fired, the lighting instructions are on the AGA rating plate. Pilot burner is lit through hole in panel at bottom of steam generator. This panel should never be left off as this will damage the controls. Burners will not light without water in the steam generator.



## WATER QUALITY REQUIREMENTS — STEAM GENERATOR PROTECTION AND MAINTENANCE

A steam generator, or boiler, unlike other types of water-using kitchen equipment distills the water in order to make steam. Nearly all feed-water sources contain dissolved minerals in varying degrees of concentration. As this water is boiled, pure steam rises from it's surface, upward to the cooking compartment(s), leaving minerals behind that can become harmful to the steam generator. If minerals are allowed to accumulate inside the steam generator, they will solidify as a scale. Then, malfunctioning will occur, and serious equipment damage may result.

The use of good quality generator feed water is the responsibility of the owner/user. The use of poor quality feed water could void equipment warranties. The minimum treatment required in most areas is water softening, although local water conditions may require more intensive pretreatment than simply a water softener.

Scale problems occur when feed water is high in hardness, total dissolved solids, silica, and alkalinity. Water softening will only reduce the water's hardness, which is the presence of dissolved salts of magnesium and calcium. Water softening will not affect the multitude of other minerals found in most water supplies. Because generator scale is the result of the precipitation of many minerals, the best property to control, for generator feed water, is total dissolved solids, not just hardness.

The recommended minimum water quality standards, whether untreated or pre-treated, based upon 10 hours of use per day, and a Daily Blowdown, are as follows:

Total Dissolved Solids	Less than	60 parts per million
Total Alkalinity	Less than	27 parts per million
Silica	Less than	13 parts per million
PH Factor	Greater than	7.5

Consult a local water treatment specialist for an on-the-premises water analysis and for recommendations concerning steam generator feed water treatment (if required). In order to remove or reduce harmful concentrations of minerals.

If the recommended water quality requirements are met without supplemental treatment, or if treatment is applied, resulting in feed water quality meeting the prescribed standard, the steam generator will need to be blown down only once each day. In addition, the inside of the generator requires an inspection (for excessive lime accumulation and consumed corrosion resistors) only once every six months. Replace the corrosion resistors and chemically descale the generator as required.

If a pre-treatment unit cannot be installed, and the recommended water quality requirements are not met, the following procedures should be followed, in order to achieve maximum steam generator service life. The steam generator should be blown down after each 6 hours of use. Have the steam generator inspected, inside and outside, by a qualified technician every 3 months. If the corrosion resistor(s) is totally or nearly consumed, replace it. If the inside of the generator is heavily coated with scale, have it chemically descaled by a qualified service technician.

## INSTRUCTIONS FOR CHEMICALLY DESCALING STEAM GENERATORS

**WARNING: Steam under pressure may cause serious injury and bodily harm when it is accidentally or carelessly released. Improper handling of acid could cause serious, permanent injury. Therefore, service of the steam generator should only be performed by trained and experienced personnel, thoroughly familiar with servicing generators.**

There are a number of commercial descaling chemicals available, produced by various manufacturers. Those utilizing a sulfamic acid and base, which can be identified by its powdered form, are safe and compatible with our food preparation equipment. It is imperative that the acid used for descaling be FDA approved for use in food preparation equipment. Various manufacturers may include additional chemicals to increase potency, and therefore, instructions for a specific brand should be followed carefully. If instructions are not provided with the descaling chemical you purchase, the following general guidelines may be followed.

**WARNING: Exercise care when handling acid. Avoid contact with skin, eyes, or clothing. Wear safety glasses or face shield, along with rubber gloves and rubber apron. In case of exposure to clothing, remove clothing and flush with water. In case of exposure to skin or eyes, flush with water for 15 minutes and get immediate medical attention. Do not take internally. Keep out of the reach of children.**

Be sure the generator has been drained, depressurized, and is cool. Open the hand hole access on the front of the generator and place approximately 8-10 pounds of sulfamic acid inside the generator. Put a new hand hole gasket on the hand hole plate, and replace the hand hole plate, tightening the bar and nut assembly to a maximum of 15 foot pounds torque. The generator must be completely filled with hot water (fill the generator beyond its normal, automatic fill point of 2/3 up in the sight gauge). On mechanical fill generators, this can be accomplished by adding weight to the float or removing the float and regulating the fill level with a hand valve in the water supply plumbing. On electric fill generators (with probes), this can be accomplished by temporarily jumpering terminals #3 & #4 of the water control relay. Turn the main on-off toggle switch to the "ON" position, then turn the switch to the "OFF" position when the generator is completely filled. Let the solution stand for several hours, then flush with water. Rinse with a solution of bicarbonate of soda of soda to neutralize any acid residue, and again, flush with water.

**CAUTION: Never tighten the hand hole plate nut when the steam generator is in use, hot, or otherwise pressurized. Never tighten nut over 15 foot pounds torque. Overtightening may cause uneven stress, which may result in the weakening and possible breakage of the plate.**

CLEVELAND RANGE CO., 1333 EAST 179th ST., CLEVELAND, OHIO 44110  
Manufacturer reserves right of design improvement or modification, as warranted.

## SERVICING INSTRUCTIONS

## PROBE SYSTEM: ELECTRIC WATER FILL AND ELECTRIC LOW WATER FUEL CUT OFF FOR STEAM GENERATOR — 3 PROBE TYPE

**WARNING: Service of the steam generator must be performed only by trained and experienced service technicians.**

During operation of the steam generator, the water level is maintained automatically by unequal length probe extensions inside. The probes and extensions must be kept clean and free of scale deposits in order to function properly.

The probe extensions are sensors in a control system which monitors and maintains the water level between the end of the short probe extension and the end of the intermediate extension.

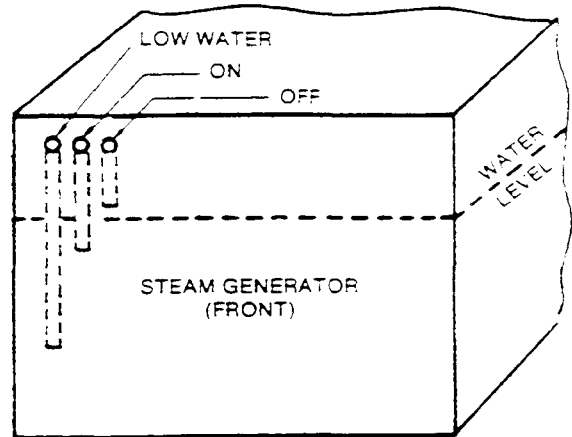
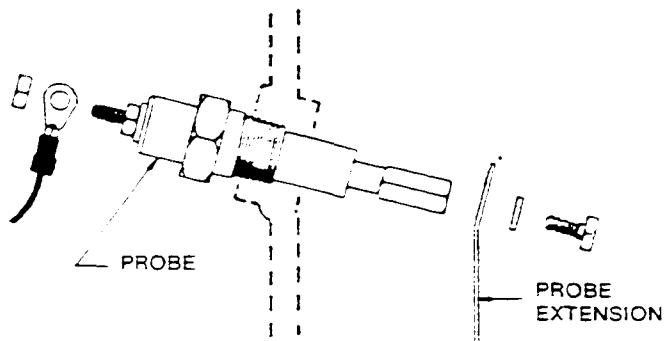

The long probe, called "Low Water," is a safety sensor which shuts off the fuel supply if there is insufficient water in the steam generator.

Since the control system is all electric and these parts don't move or wear, they can be expected to have a long life. If they do malfunction, it is generally because untreated hard feed water is being used in the steam generator. This forms scale on the submerged ends of the probe extensions and on the top horizontal surfaces of the probes. After this scale is removed, the parts will function properly.

To eliminate the cause of scaling, refer to separate data sheets for feed water treatment information and corrosion protector servicing instructions. Probes and probe extensions should be wiped clean each time the corrosion protector is replaced.

Erratic operation may result from loose connections on either end of the probe. The external end of the probe has a nut to hold the wiring terminal snugly to the probe. This nut, if loose, may be tightened, firmly but gently. Too much torque will turn the center piece of the probe and misalign the attached probe extension inside, causing the probe to become inoperative.

Inside the steam generator, the screw which holds the probe extension to the probe may be loose, allowing the probe extension to swing or rest against some part of the steam generator. This can be corrected by removing the hand hole plate and reaching inside to align and hold the probe extensions vertically while tightening the screws.

### To Service the Probes or the Probe Extensions

1) Turn off all utilities and fuel to steam generator. Drain Steam generator.

**CAUTION: Never work on the steam generator when it is hot or pressurized.**

- 2) Remove probe cover on outside of steam generator to expose probe terminals. Examine for loose wiring terminals
- 3) Remove hand hole cover plate from steam generator. See separate data sheet for instructions.
- 4) Remove probe extensions from probes on inside of steam generator, clean off scale, and re-install. Or install new probe extensions if preferred.
- 5) Remove scale from the probe (see sketch above). Do not use an abrasive on the teflon insulator. If the old probe needs replacement, install a new one.

(CONTINUED ON THE REVERSE SIDE)

CLEVELAND RANGE, INC., 1333 EAST 179th ST., CLEVELAND, OHIO 44110

Manufacturer reserves right of design improvement or modification, as warranted.

LITHO IN U.S.A

## SERVICING INSTRUCTIONS

## PROBE SYSTEM: ELECTRIC WATER FILL AND ELECTRIC LOW WATER FUEL CUT OFF FOR STEAM GENERATOR — 3 PROBE TYPE

6) Assemble probe extensions to probes on inside of steam a generator so they hang an vertically, parallel to each other. Malfunctioning will occur if an extension touches any part of the steam generator or another probe extension.

7 ) If insulation on electrical wires to the probe shows signs of being broken, cut, or deteriorated, the wires should be replaced.

8) Connect wire terminals on outside of steam generator to probe terminals as follows:

Red wire to the shortest probe. Turns water off.

Black wire to the intermediate probe. Turns water on.

White wire to the longest probe. Shuts off fuel (low water safety fuel shut-off).

9) Re-install hand hole plate and install a new gasket.

The hand hole plate should be cleaned and examined each time it is removed. If the plate is chipped or cracked, it should be replaced immediately. Because continuous use and possible abuse can cause metal fatigue, which weakens the hand hole plate, a new one should be installed at least every three years. Replace the gasket at least once a year —or sooner if it is cracked or hardened.

10) Replace probe cover and check to make sure that the cover does not contact probes.

11) Close steam generator drain valve. Turn on utilities and fuel supply to steam generator.

12) Operate and observe steam generator long enough to insure that it is functioning properly.

### Low Water Fuel Cut Off Test

Proper operation of the "Low Water" probe extension should be checked periodically by someone who is thoroughly familiar with the equipment.

**To Test:** Open the drain of the steam generator while fuel is on. When the water has drained below the "Low Water" probe, the fuel should shut off automatically. Indication of fuel shut off should occur just as the water level in the sight gauge drops from view. If it does, close the drain, allow the steam generator to refill, and resume normal operations. If the fuel does not shut off, immediately turn the on-off toggle switch to the "off" position, and follow the steps outlined under "To Service the Probes or the Probe Extensions" as given on the reverse side of this sheet.

For specific information pertaining to the operation of the electric water fill controls, and electric low water safety fuel cut-off, refer to the following data sheets:

Electric Steam Generators

Gas-Fired Steam Generators

Steam Coil (electric operated) Generators

# STANDING PILOT-IGNITION TYPE GAS CONTROLS FOR GAS-FIRED STEAM GENERATORS

**CAUTION: The following procedures, as well as other work on the gas controls, should be performed only by a trained and experienced service technician, thoroughly familiar with gas controls.**

Built in gas controls assure safe and automatic operation of the pilot and main burners of the steam generator.

The control's consist of a pilot generator (thermocouple) and a unit called the combination gas control. This latter unit consists of a gas valve operator and servo gas pressure regulator.

Generally, there is no need to make an adjustment to any portion of the gas system. The main burner orifices and the pilot burner orifice installed at the factory are correct for the kind of gas specified on the purchase order. Also, the primary air supply to the main burner is properly adjusted for complete combustion.

### Lighting and Shutdown Instructions

Flip electrical switch on. Open water valve. Open gas valve. Slightly depress and turn control knob to "off" for 5 minutes before lighting gas. Turn control knob to "pilot," depress it completely, and light pilot burner. Continue to hold knob in for about 60 seconds, then release. Pilot burner is lighted through hole in panel at bottom of steam generator. Never leave panel off. As this will damage controls. Turn control knob to "on". Depress electrical switch for main burner ignition. Burners will not light without water in the steam generator. For main burner off, with pilot on, turn control knob to "pilot". For main and pilot burner off, slightly depress and turn control knob to "off". Flip electrical switch off.

Occasionally, due to regional differences in the gas supply, the pilot burner flame may require adjustment.

A normal flame is mostly blue and steady, and envelops 3/8" to 1/2" of the tip of the pilot generator, as illustrated at right.

The pilot gas adjusting screw can be found under a cover screw located near the gas control knob, illustrated below.

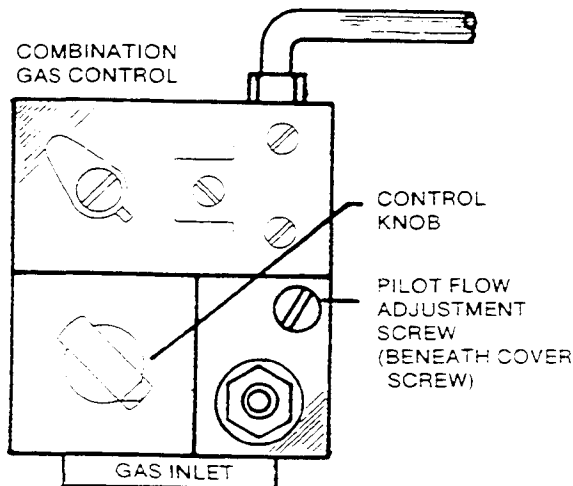
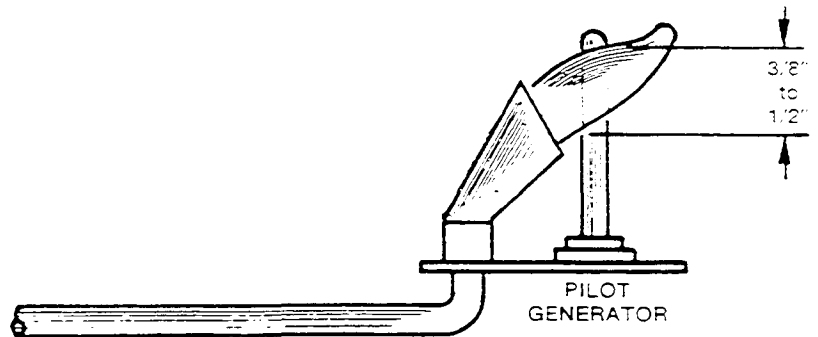

To adjust the pilot flame:

1) Remove the pilot adjustment cover screw.

2) Turn PILOT FLOW ADJUSTMENT SCREW clockwise to decrease or counterclockwise to increase pilot flame.

3; **WARNING: Be sure to replace cover screw** after adjustment to prevent possible gas leakage.

Electrical connections in the pilot generator circuit must be clean and secure.

Because the pilot generator operates in a severe environment, it may eventually need a replacement. The time before replacement will vary from one piece of equipment to another, depending on the amount of usage. The pilot generator (thermocouple) should generate 450-750 MV in an open circuit condition.

When a malfunction is traceable to the combination gas control unit, it is recommended that the entire unit be replaced with a new one, rather than attempting repairs to the old unit.

**WARNING: To prevent the danger of possible gas leakage, the installer must be a trained and experienced service technician, thoroughly familiar with gas controls.**

CLEVELAND RANGE, INC., 1333 EAST 179th ST., CLEVELAND. OHIO 44110

1053

LITHO IN U.S.A.

Manufacturer reserves right of design improvement or modification, as warranted.

## HOW THE ELECTRIC (WARRICK RELAY) WATER LEVEL CONTROLS OPERATE — ON GAS FIRED STEAM GENERATORS (WITH 3 PROBES)

Inside Cleveland Range Co. boilers which have electric water level controls, there are three probe extensions vertically oriented above the water with their lower ends positioned at various levels.

Water is admitted to the boiler and is shut off in response to the water level sensed by the tips of the short and the medium length probe extensions. The electrical conductance of the water is used in this system for controlling its level.

The third probe extension is a low water safety cutout sensor and operates on the same principle.

### Operation Sequence — Water Level Control

Assume an empty boiler. To fill, close Switch S for the following operations:

- 1) Solenoid SV2 is energized allowing the boiler to fill with water at the same time the primary circuit of Transformer T1 is also energized.
- 2) The boiler will continue to fill until the water level reaches the Water Off probe extension completing the T1 secondary circuit, and energizing Relay Coil RC1
- 3) When Relay Coil RC1 is energized the normally closed contact opens, de-energizing Solenoid SV2 stopping the water fill. The normally open contact is closed, completing the circuit to the Water On probe.

When the water boils away below the end of the Water On probe extension the following occurs:

- 1) The secondary circuit of Transformer T1 is broken and the Relay Coil RC1 is de-energized.
- 2) When Relay Coil RC1 is de-energized the normally open contact opens, breaking the circuit to the Water Off probe extension. And the normally closed contact closes, energizing Solenoid SV2 allowing the boiler to fill as in Step 2 above.

### Operation — Low Water Safety Cutout

When Switch S is closed the following operations occur:

- 1) The primary circuit of Transformer T1 is energized.
- 2) When the water level reaches the low water safety cutout probe extension and the momentary reset switch is manually closed. Relay Coil RC2 is energized.
- 3) When Relay Coil RC2 is energized the normally open contacts close, completing the low water safety circuit through Contacts 7 and 8 and completing the circuit through Contacts 3 and 4, completing the 750 millivolt pilot generator circuit and allowing the gas control package valve to operate.

If the water level drops below the Low Water Safety Cutout probe extension, the following occurs:

- 1) The secondary circuit of Transformer T2 is broken and the Relay Coil RC2 is de-energized. Contacts 7 and 8 and 3 and 4 open, breaking the 750 millivolt circuit

## GAS BOILER CONTROL CIRCUIT

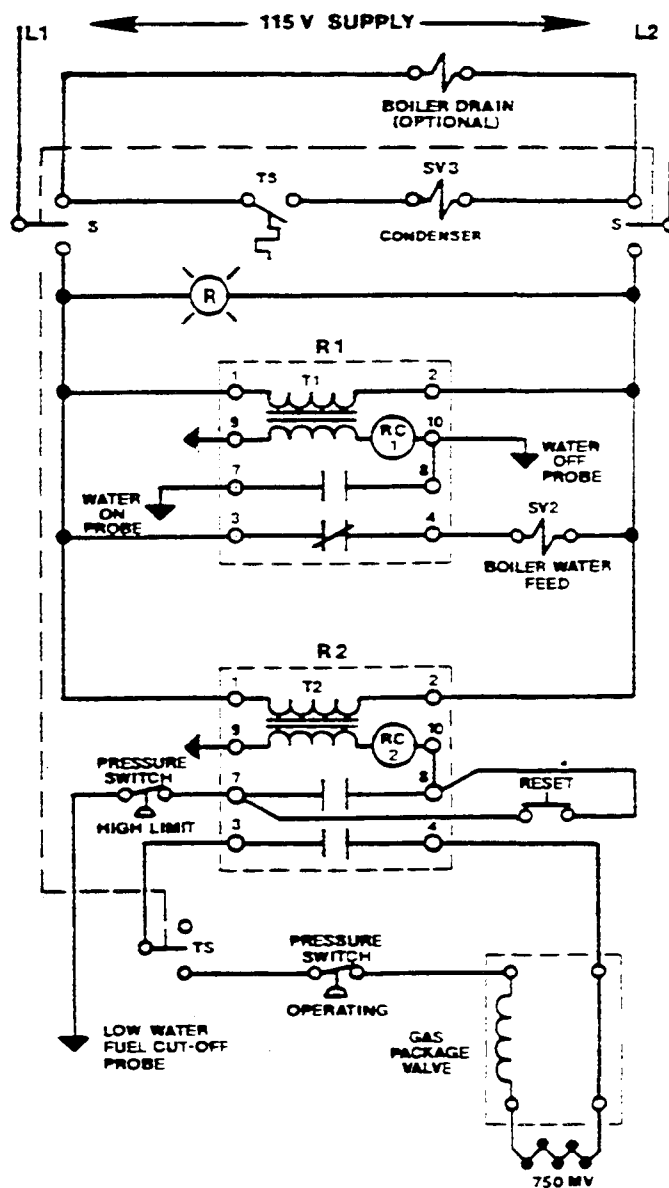

which shuts off the flow of gas to the burners.

The burners will not operate until water level in the boiler is normal and the reset switch is operated.

### Operation-Boiler Drain Condenser

To activate the Boiler Drain Condenser System close switch S by placing toggle in the down position.

To drain boiler, open boiler drain ball valve. The heat from the boiler drain water will close the normally open thermal switch TS and energize the condenser solenoid valve SV3. To deactivate the Boiler Drain Condenser System open switch S by moving toggle to center off position.

CLEVELAND RANGE CO., 1333 EAST 179th ST., CLEVELAND, OHIO 44110  
Manufacturer reserves right of design improvement or modification, as warranted.

## HOW THE ELECTRIC (WARRICK RELAY) WATER LEVEL CONTROLS OPERATE — ON ELECTRIC STEAM GENERATORS (WITH 3 PROBES)

Inside Cleveland Range Co. boilers which have electric water level controls, there are three probe extensions vertically oriented above the water with their lower ends positioned at various levels.

Water is admitted to the boiler and is shut off in response to the water level sensed by the tips of the short and the medium length probe extensions. The electrical conductance of the water is used in this system for controlling its level.

The third probe extension is a low water safety cutout sensor and operates on the same principle.

### Operation Sequence — Water Level Control

Assume an empty boiler. To fill, close Switch S for the following operations:

- 1) Solenoid SV2 is energized allowing the boiler to fill with water at the same time the primary circuit of Transformer T1 is also energized.
- 2) The boiler will continue to fill until the water level reaches the Water Off probe extension completing the T1 secondary circuit, and energizing Relay Coil RC1.

3) When Relay Coil RC1 is energized the normally closed contact opens, de-energizing Solenoid SV2 stopping the water fill. The normally open contact is closed, completing the circuit to the Water On probe.

When the water boils away below the end of the Water On probe extension the following occurs:

- 1) The secondary Circuit of Transformer T1 is broken and the Relay Coil RC1 is de-energized.
- 2) When Relay Coil RC1 is de-energized the normally open contact opens, breaking the circuit to the Water Off probe extension. And, the normally closed contact closes, energizing Solenoid SV2 allowing the boiler to fill as in Step 2 above.

### Operation — Low Water Safety Cutout

When Switch S is closed the following operations occur

- 1) The primary circuit of Transformer T2 is energized.
- 2) When the water level reaches the low water safety cutout probe extension and the momentary reset switch is manually closed. Relay Coil RC2 is energized.
- 3) When Relay Coil RC2 is energized the normally open contacts close, completing the low water safety circuit through Contacts 7 and 8, and completing the circuit through Contacts 3 and 4, energizing Contactor Coil C1 which closes the heater circuit.

If the water level drops below the Low Water Safety Cutout probe extension, the following occurs:

- 1) The secondary circuit of Transformer T2 is broken and the Relay Coil RC2 is de-energized. Contacts 7 and 8 and 3 and 4 open, breaking the circuits to Contactor C1 thereby turning off the heaters.

## ELECTRIC BOILER CONTROL CIRCUIT

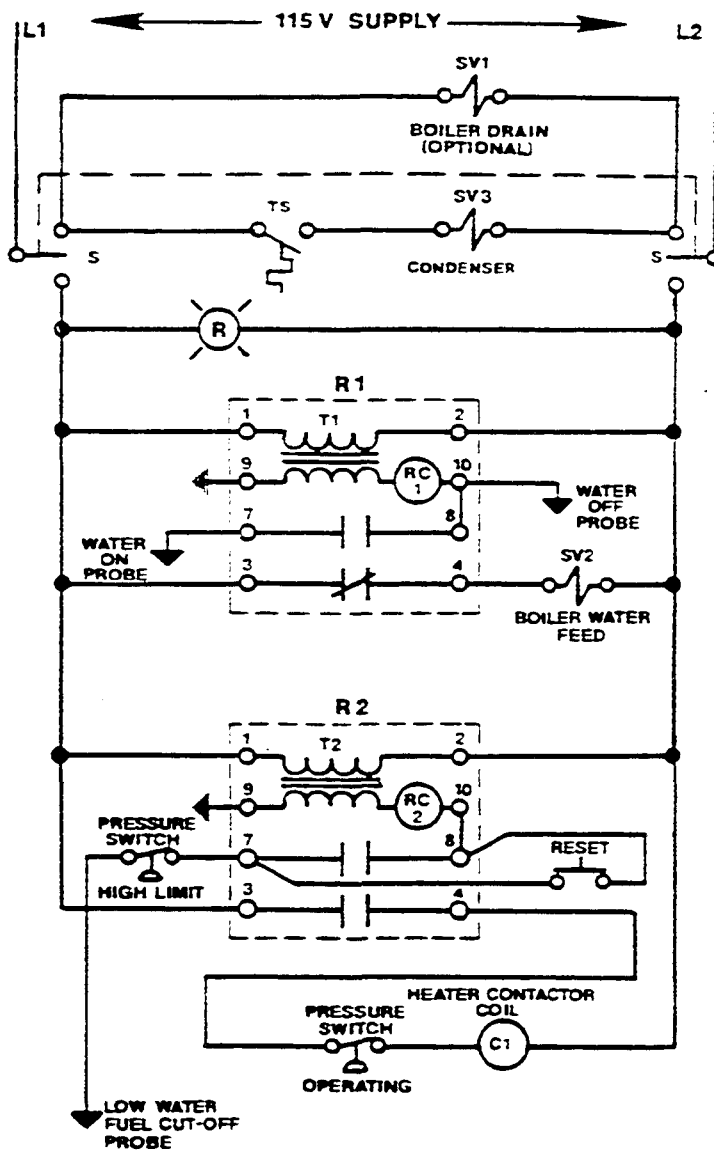

The Contactor C1 will not operate until water level in the boiler is normal and the reset switch is operated.

### Operation-Boiler Drain Condenser

To activate the Boiler Drain Condenser System, close switch S by placing toggle in the down position.

To drain boiler, open boiler drain ball valve. The heat from the boiler drain water will close the normally open thermal switch TS and energize the condenser solenoid valve SV3. To de-activate the Boiler Drain Condenser System open switch S by moving toggle to center off position.

CLEVELAND RANGE CO., 1333 EAST 179th ST., CLEVELAND, OHIO 44110  
Manufacturer reserves right of design improvement or modification, as warranted. 0482

**ELECTRIC STEAM GENERATOR (BOILER) ASSEMBLY — 3 PROBE TYPE 24KW, 30KW, & 48KW (2, 3, & 4 HEATER ELEMENTS) — 1968 to PRESENT**

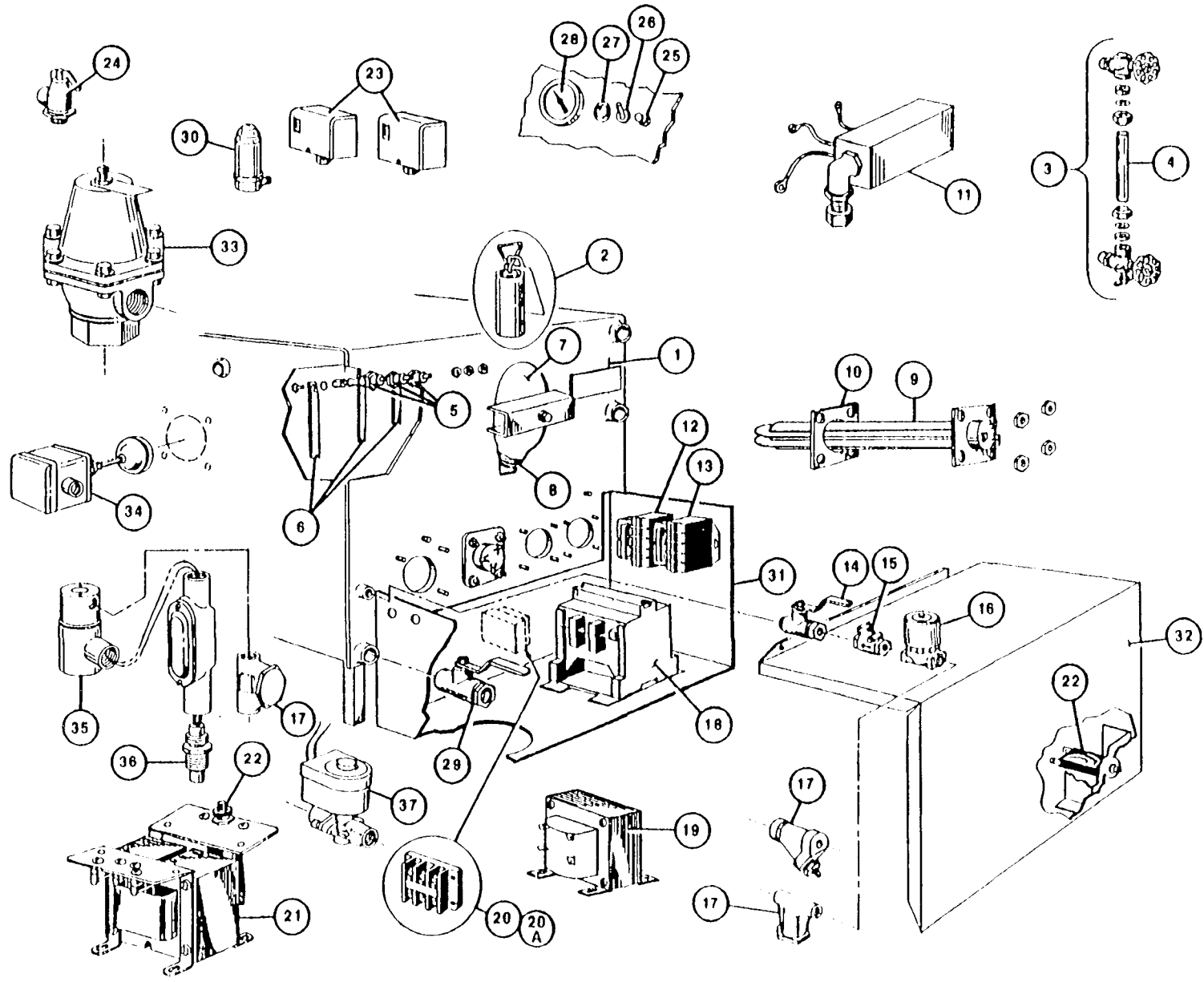

**CLEVELAND RANGE CO., 1333 EAST 179th ST., CLEVELAND, OHIO 44110**  
 Manufacturer reserves right of design improvement or modification, as warranted.

## ELECTRIC STEAM GENERATOR (BOILER) ASSEMBLY — 3 PROBE TYPE 24KW, 36KW, & 48KW (2, 3, & 4 HEATER ELEMENTS) — 1968 to PRESENT

REFERENCE NUMBER	PART NUMBER	DESCRIPTION
1	43936	Boiler shell only. with legs. hand hole plate assembly. mounting studs for 3" square-flanged heater elements.
	43938	Boiler shell (43937) above. also including two corrosion resistors, sight gauge, three probes and extensions with cover box.
2	43895	Corrosion resistor, with hanger.
3	40445	Water gauge set with glass.
	07108	Fibre washer (2 required)
	23132	Gauge glass washer (2 required).
4	07302	Glass only 6" long.
5	40462	Probe with lock washer and screw.
6	101467	Probe extension set (3).
7	40421	Hand hole plate ass'y., including bar, nut, and gasket.
	43748	Hand hole plate only.
8	07106	Hand hole gasket, flat. 4" x 6" oval
9	08165	Electric immersion heater, with gasket. 3" flange. 12KW. 208/220 volt, 3 phase.
	08166	Electric immersion heater, with gasket. 3" flange, 12KW. 230/240 volt, 3 phase.
	08167	Electric immersion heater, with gasket 3" flange, 12KW. 440/480 volt. 3 phase.
	08214	Electric immersion heater, with gasket 3" flange. 12KW. 208/220 volt. 1 phase.
	08215	Electric immersion heater, with gasket 3" flange. 12KW. 230/240 volt, 1 phase.
	08216	Electric immersion heater, with gasket. 3" flange, 12KW. 440/480 volt, 1 phase.
	08175	Electric immersion heater, with gasket. 2 1/2" flange, 12KW. 208/220 volt. 3 phase
	08176	Electric immersion heater, with gasket 2 1/2" flange, 12KW. 230/240 volt. 3 phase.
	08177	Electric immersion heater, with gasket. 2 1/2" flange, 12KW. 440/480 volt. 3 phase
10	07128	Heater gasket — 3" square.
	07115	Heater gasket — 2 1/2" square.
11	53250	Probe cover.
12	03504	Water control relay, 115 volt (1D1DO).
13	03514	Low water cut-off relay, 115 volt, (1C1DO).
14	03276	1/4" ball valve water supply shutoff.
15	22102	1/4" check valve.
16	44095	1/2" water feed solenoid valve.
17	19870	1/4" line strainer.
18	03509	Contactors — 50 amp.
	03506	Contactors — 75 amp.
19	20533	Transformer, 75VA, (All, except Convection Steamers).
20	02193	Heavy duty terminal block — use with more than one contactor (125 amp size).
20A	02196	Heavy duty terminal block — use with more than one contactor (250 amp size). 24KW, 220 volt, single phase and 48KW, 208, 220 & 240 volt. three phase
21	20535	Transformer. 150VA, (Convection Steamers only).
22	03202	Circuit breaker for 20535.
23	19947	Pressure switch (Models after 1-70)
24	22130	Safety valve — 8 psi
	22131	Safety valve — 15 psi
25	19968	Reset switch.
26	19944	On-Off power switch. 115/220 volt DPST (before 1-78).
	19967	On-Off power switch. 115 volt 3PDT (after 1-78) and all auto blowdown.
27	12161	Signal light, 115/220 volt, 1"
	12169	Signal light, 115/220 volt. 1/2" (Pressure Steamers only).
28	07173	Steam pressure gauge, rear mount. 0-30 psi. 2 1/2"
	07168	Steam pressure gauge, rear mount. 0-30 psi, 2" (Pressure Steamers only)
29	03277	Generator drain valve — ball type
30	22140	Air vent.
31	40471	Control enclosure.
32	52568	Cover, control enclosure.
33	22122	3/4" pressure reducing valve, 3-15 psi output (optional).
34	19945	Float switch with gasket — low water cut off (California only).
35	22104	1/4" solenoid valve — boiler condenser water supply
36	19979	Thermal switch — boiler condenser.
37	22106	Valve, solenoid. 1/2" boiler auto blowdown, 115 volt (optional)

CLEVELAND RANGE CO., 1333 EAST 179th ST., CLEVELAND, OHIO 44110  
Manufacturer reserves right of design improvement or modification, as warranted. LITHO IN



# WIRING DIAGRAM ELECTRIC STEAM GENERATORS

**WIRING DIAGRAM FOR ELECTRIC STEAM GENERATORS  
WITH ELECTRICAL LOW-WATER HEATER CUTOFF,  
WITHOUT MANUAL SAFETY RESET CIRCUIT  
PRIOR TO JANUARY, 1978**

We are aware of the poor quality and are making arrangements with the Manufacturer for a better copy.

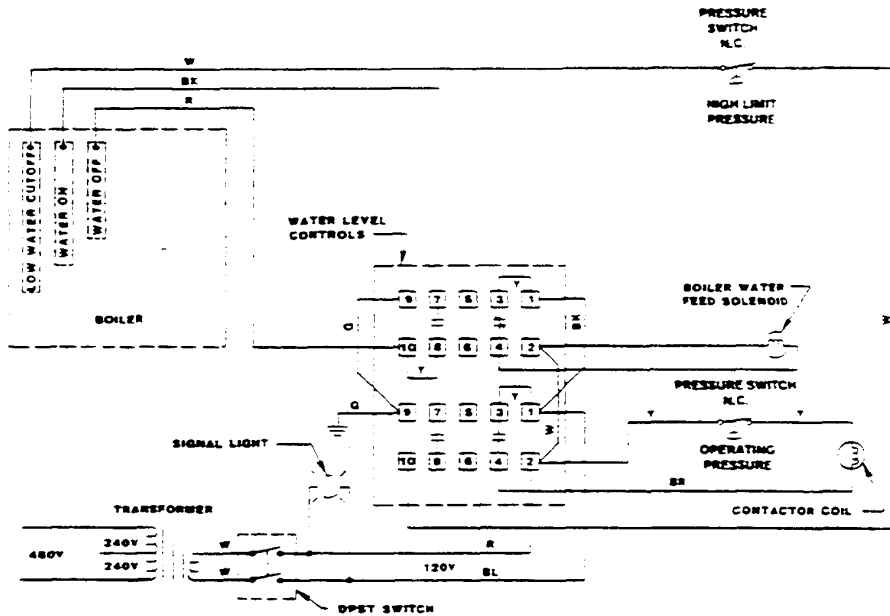

**WIRING DIAGRAM FOR ELECTRIC STEAM GENERATORS  
WITH ELECTRICAL LOW-WATER HEATER CUTOFF,  
WITH MANUAL SAFETY RESET CIRCUIT  
AFTER JANUARY, 1978**

COLOR CODE  
W - WHITE      BR - BROWN  
R - RED        BL - BLUE  
Y - YELLOW    BK - BLACK  
G - GREEN

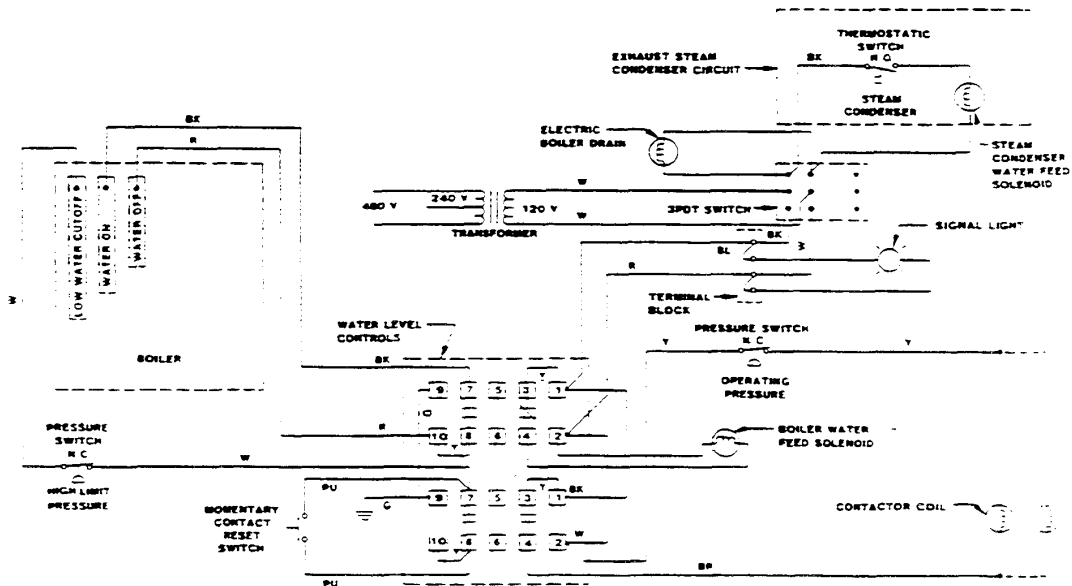

COLOR CODE  
BK - BLACK      G - GREEN  
BL - BLUE       R - RED  
BR - BROWN    W - WHITE  
PU - PURPLE    Y - YELLOW

CLEVELAND RANGE CO., 1333 EAST 179th ST., CLEVELAND, OHIO 44110

0882 LITHO IN U.S.A

Manufacturer reserves right of design improvement or modification As warranted.

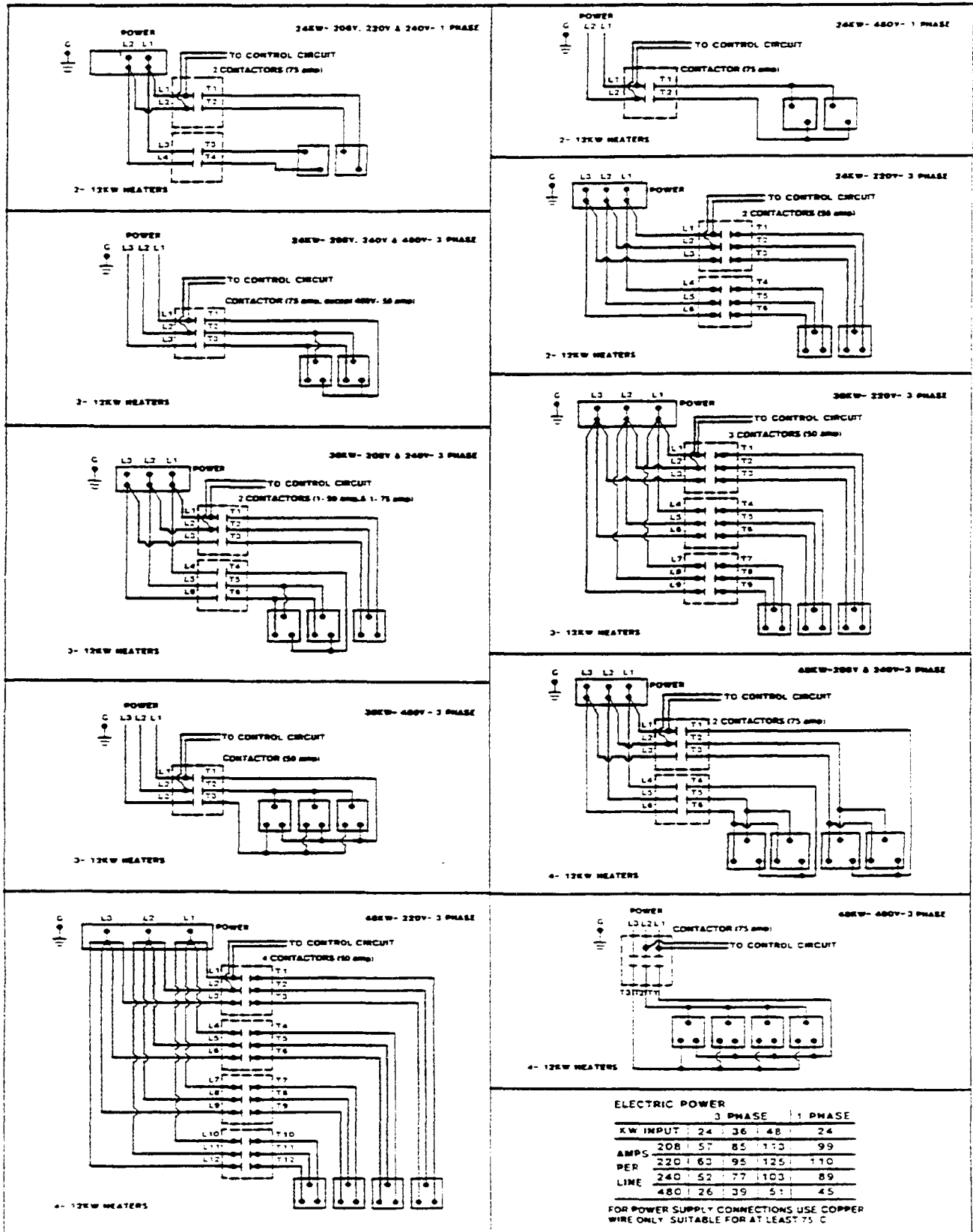

**ELECTRIC POWER**

	3 PHASE			1 PHASE
KW INPUT	24	36	48	24
AMPS PER LINE	208	57	85	113
PER LINE	220	63	95	125
LINE	240	52	77	103
	480	26	39	51

FOR POWER SUPPLY CONNECTIONS USE COPPER WIRE ONLY SUITABLE FOR AT LEAST 75 C

**GAS STEAM GENERATOR (BOILER) ASSEMBLY — 3 PROBE TYPE  
160,000 BTU (3 BURNER) & 200,000 BTU (4 BURNER)**

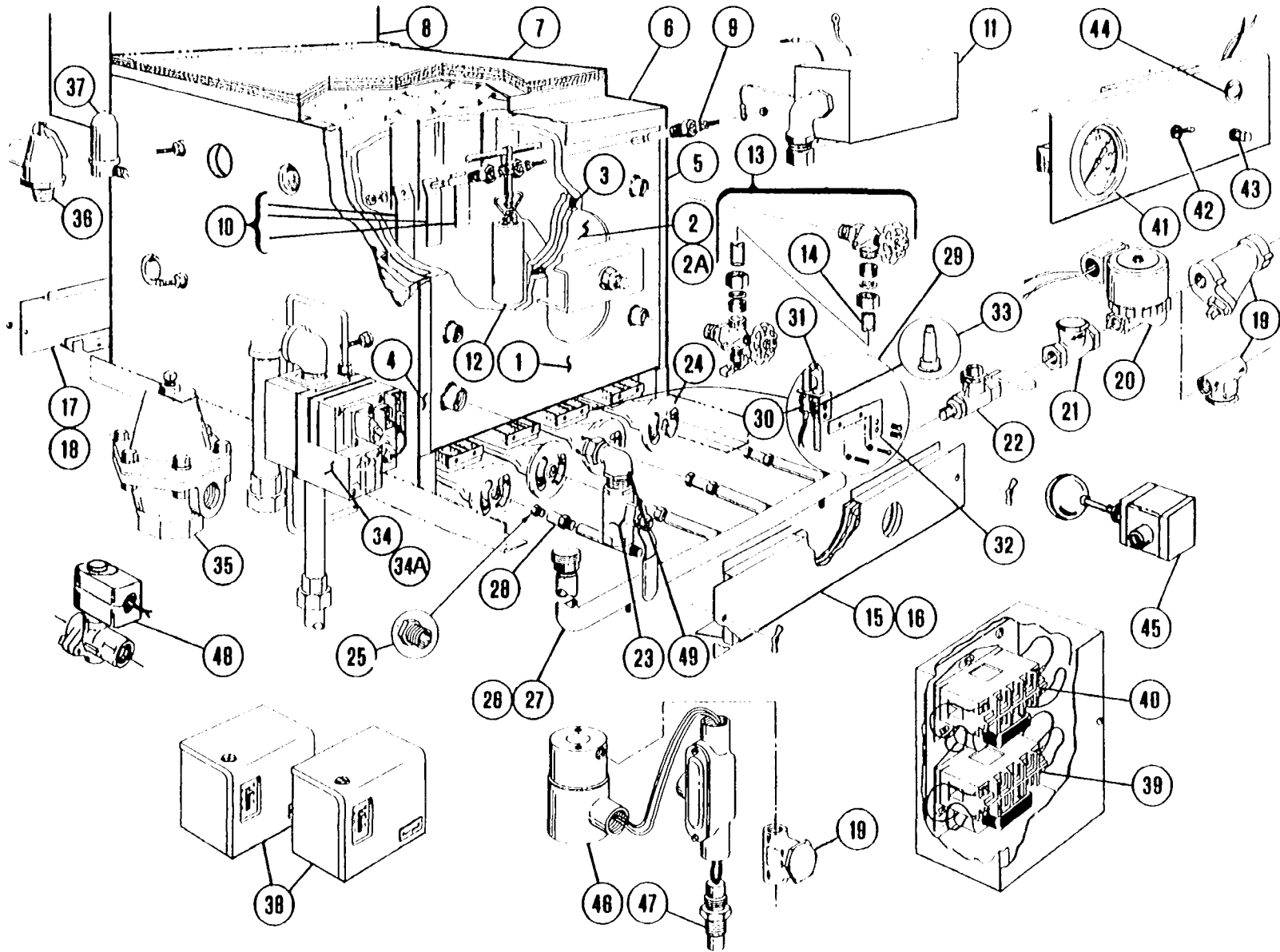

**CLEVELAND RANGE CO., 1333 EAST 179th ST., CLEVELAND, OHIO 44110**

0985 LITHO IN U.S.A.. Manufacturer reserves right of design improvement or modification, as warranted.

## GAS STEAM GENERATOR (BOILER) ASSEMBLY — 3 PROBE TYPE 160,000 BTU (3 BURNER) & 200,000 BTU (4 BURNER)

REFERENCE NUMBER	PART NUMBER	DESCRIPTION
1	43872 40298	Boiler shell only. with legs. studs. hand hole plate assembly, and top flue bracket Boiler shell 43872 above, also including two corrosion resistors, sight gauge, insulation panels, top flue collector with insulation and cover plate, three probes and extensions with cover box.
2	40421	Hand hole plate assembly, including bar. nut and gasket
2A	43748	Hand hole plate only.
3	07106	Hand hole gasket flat 4x6 oval.
4	43941	Left side insulating panel assembly.
5	43943	Right side insulating panel assembly
6	56320	Top flue collector-
	40115	Top insulation baffle assembly (flat).
	40116	Top insulation baffle assembly (with flange)
8	42360	Internal flue riser assembly.
9	40462	Probe with lock washer and screw.
10	40455	Probe extension set (3).
11	52350	Probe cover.
12	43895	Corrosion resistor.
13	40445	Water gauge set with glass.
	07108	Fibre washer (2 required).
	23132	Gauge glass washer (2 required).
14	07302	Glass only — 6" long.
15	43851	3-burner front baffle assembly — Natural Gas.
	43855	3-burner front baffle assembly — LP. Gas.
16	43852	4-burner front baffle assembly — Natural Gas.
	43856	4-burner front baffle assembly — L.P. Gas.
17	41365	3-burner rear burner support (after 7-76).
	69952	3-burner rear burner support (before 7-76).
18	41366	4-burner rear burner support (after 7-76).
	69953	4-burner rear burner support (before 7-76).
19	19870	1/4" line strainer.
20	44095	1/2" water feed solenoid valve.
21	22102	1/4" check valve.
22	03276	1/4" ball valve — water supply shut-off.
23	03277	Generator drain valve — ball type.
24	02499	Main gas burner.
25	15453	Main burner orifice — Natural Gas.
	15450	Main burner orifice — L.P. Gas.
26	40901	Gas manifold assembly — 3 burner (after 7-76).
	40905	Gas manifold assembly — 3 burner (before 7-76).
27	40902	Gas manifold assembly — 4 burner (after 7-76).
	40906	Gas manifold assembly — 4 burner (before 7-76).
28	19632	Orifice holder (after 7-76).
	19631	Orifice holder (before 7-76).
29	43651	Pilot generator assembly with 02505 burner. 20410 thermocouple. 52449 bracket and 15460 orifice.
	43653	Pilot generator assembly with 02523 burner. 20410 thermocouple. 52449 bracket and 15461 orifice.
30	20410	Pilot thermocouple.
31	02505	Pilot burner — Natural Gas.
	02523	Pilot burner — L.P. Gas-
32	52449	Pilot bracket
33	15460	Pilot burner orifice — Natural Gas.
	15461	Pilot burner orifice — L.P. Gas.
34	22182	1/2" combination gas control valve — Natural Gas.
34A	22096	1/2" combination gas control valve — L.P. Gas.
35	22122	3/4" pressure reducing valve. 3-15 psi output (optional).
36	22130	Safety valve — 8 psi.
	22131	Safety valve — 15 psi.
37	22140	Air vent
38	19947	Pressure switch.
39	03514	Low water cut-off relay. 115 volt, (1 C1DO).
40	03504	Water control relay. 115 volt, (1 D1 DO).
41	07173	Steam pressure gauge, rear mount, 0-30 psi.
42	19967	On-Off power switch, 115/220 volt, 3 PDT.
43	19968	Reset switch.
44	12161	Signal light 115/220 volt
45	19945	Float switch with gasket — low water cut-off (California only)
46	22104	1/4" solenoid valve — boiler condenser water supply.
47	19979	Thermal switch — boiler condenser.
48	22106	Valve, solenoid, 1/2" boiler auto blowdown, 115 volt (optional).
49	05263	Radiator Ell 3/4" union.

**CLEVELAND RANGE CO., 1333 EAST 179th ST., CLEVELAND, OHIO 44110**

250,000 BTU (5 BURNERS) ft 300,000 BTU (6 BURNERS)

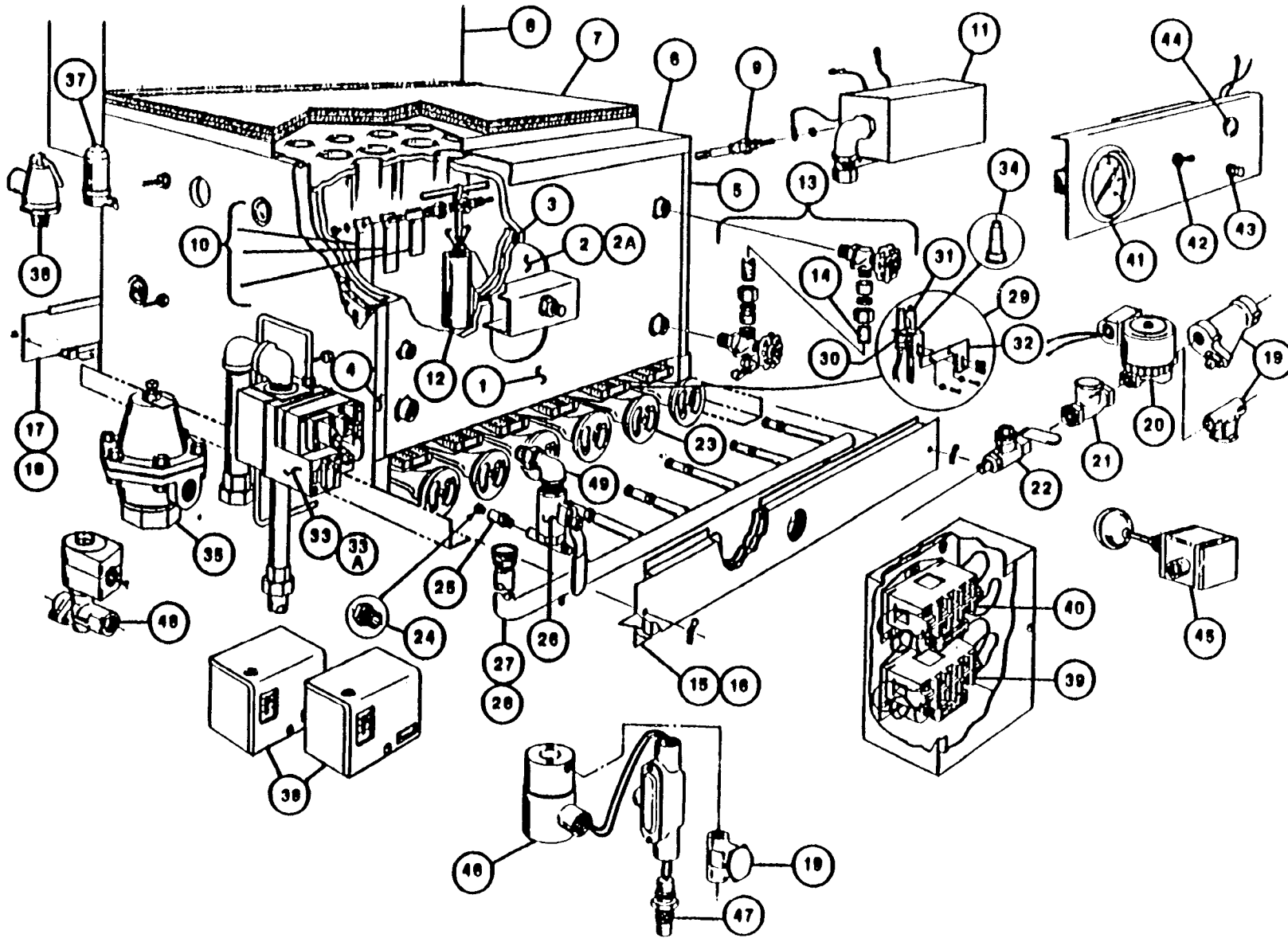

CLEVELAND RANGE, INC.. 1333 EAST 179th ST., CLEVELAND, OHIO 44110  
Manufacturer reserves right of design improvement or modification, as warranted.

# GAS STEAM GENERATOR (BOILER) ASSEMBLY — 3 PROBE TYPE

## 250,000 BTU (5 BURNERS) & 300,000 BTU (6 BURNERS)

REFERENCE NUMBER	PART NUMBER	DESCRIPTION
1	43683 40297	Boiler shell only, with legs, studs, hand hole plate assembly, and top flue bracket. Boiler shell 43873 above, also including two corrosion— resistors, sight gauge, insulation panels, top flue collector with insulation and cover plate, three probes and extensions with cover box.
2	40421	Hand hole Plate Assembly only including bar, nut and gasket.
2A	43748	Hand hole plate only.
3	07106	Hand hole gasket, flat 4x6 oval.
4	43942	Left side insulating panel assembly.
5	43943	Right side insulating panel assembly.
6	56321	Top flue collector.
7	40117	Top insulation baffle assembly (flat).
	40118	Top insulation baffle assembly (with flange).
8	42361	Internal flue riser assembly.
9	40462	Probe with lock washer and screw.
10	40455	Probe extension set (3).
11	52350	Probe Cover.
12	43895	Corrosion resistor.
13	40445	Water gauge set with glass.
	07108	Fibre washer (2 Required).
	23132	Gauge glass washer (2 Required).
14	07302	Glass Only - 6" long.
15	43853	5 burner front baffle assembly — Natural Gas.
	43857	5 burner front baffle assembly — L.P. Gas.
16	43854	6 burner front baffle assembly — Natural Gas.
	43858	6 burner front baffle assembly— L.P. Gas.
17	41367	5 burner rear— burner support (after 7-76).
	69954	5 burner rear— burner support (before 7-76).
18	41388	6 burner rear— burner support (after 7-76).
	69955	6 burner rear— burner support (before 7-76).
19	19870	1/4" line strainer.
20	44095	1/2" water feed solenoid valve.
21	22102	1/4" check valve.
22	03276	1/4" ball valve- water supply shut off.
23	02499	Main gas burner.
24	15453	Main burner orifice — Natural Gas.
	15450	Main burner orifice — L.P. Gas.
25	19632	Orifice Holder (after 7-76).
	18631	Orifice Holder (before 7-76).
26	03277	Generator drain valve— ball type.
27	40903	Gas manifold assembly — 5 burner (after 7-76).
	40897	Gas manifold assembly — 5 burner (before 7-76).
28	40904	Gas manifold assembly --- 6 burner (after 7-76).
	40908	Gas manifold assembly — 6 burner (before 7-76).
29	43852	Pilot generator assembly with 02505 burner, 20411 thermocouple, and 52449 bracket.
30	20411	Pilot thermocouple.
31	02505	Pilot burner — Natural Gas.
	02523	Pilot burner—L.P. Gas.
32	52449	Pilot bracket.
33	22183	3/4" combination gas control valve—Natural Gas.
33A	22189	3/4" Combination gas control valve—L.P. Gas.
34	15460	Pilot burner orifice—Natural Gas.
	15461	Pilot burner orifice—L.P. Gas.
35	22122	3/4" pressure reducing valve, 3-15 psi output (optional).
36	22130	Safety valve—8 psi.
	22131	Safety valve ---15 psi.
37	22148	Air Vent.
38	19947	Pressure Switch.
39	03514	Low water cutoff relay,. 115 volt, (1C1 D0).
40	03504	Water control relay, 115 volt, (1D1D0).
41	07173	Steam pressure gauge, rear mount, 0--30 psi.
42	19967	On-Off power switch, 115/220 volt, 3 PDT.
43	19968	Reset switch.
44	12161	Signal light, 115/220 volt.
45	19945	Float switch with gasket — low water cut off (California only)
46	22104	1/4" solenoid valve— boiler condenser water supply.
47	19979	Thermal switch — boiler condenser.
48	22106	Valve, solenoid, 1/2" boiler auto blowdown, 115 volt (optional)
49	05263	Radiator Ell, 3/4" union.

**CLEVELAND RANGE, INC., 1333 EAST 179th ST., CLEVELAND, OHIO 44110**

Manufacturer reserves right of design improvement or modification, warranted.

**WIRING DIAGRAM FOR 100,000 and 150,000 BTU STEAM GENERATORS, WITH PILOT IGNITION,  
WITH AND WITHOUT SAFETY RESET CIRCUIT**

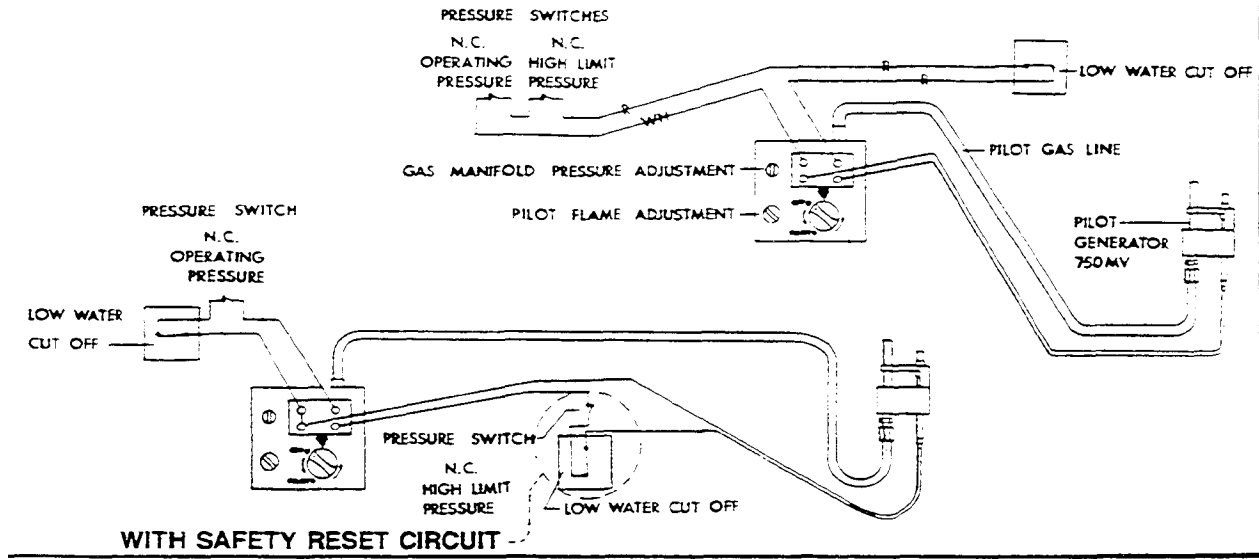

**WIRING DIAGRAM FOR 210,000 BTU STEAM GENERATORS, WITH PILOT IGNITION,  
WITH MANUAL SAFETY RESET CIRCUIT**

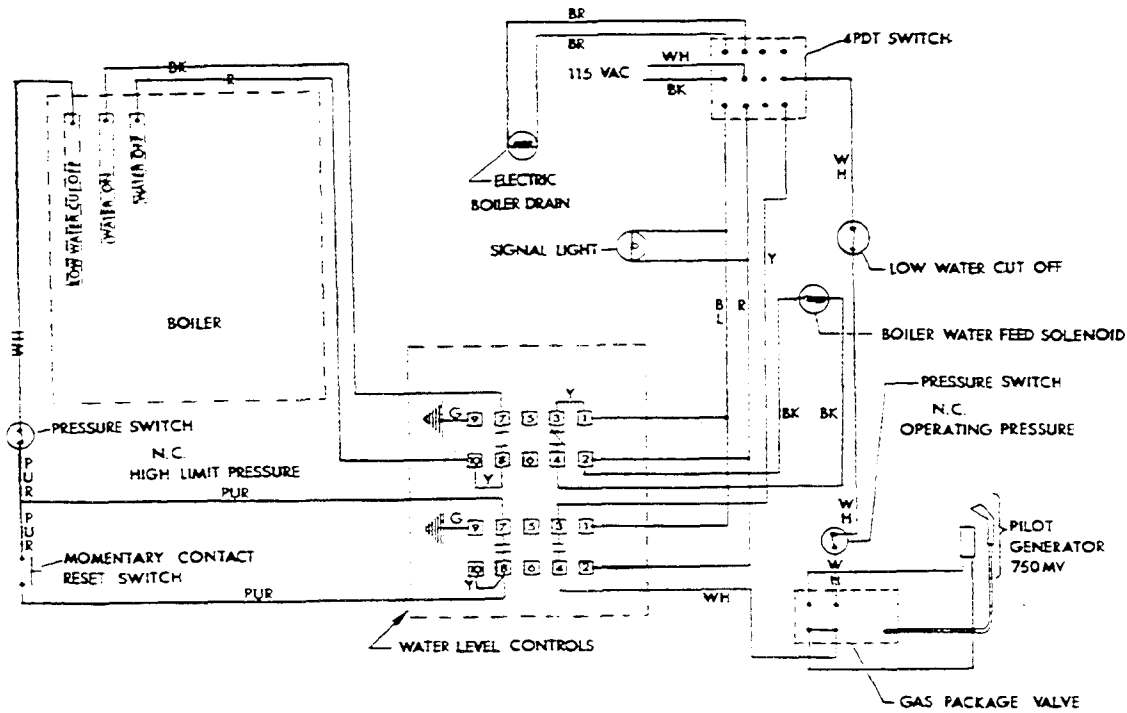

GAS	WATER	DRAINAGE	ELECTRIC CONTROL 115v	
1/2" FPT-AGA Model 150-M 150,000 BTU. 3/4" FPT-AGA Model 210-M 210,000 BTU. Reduce input 4% per 1,000 ft. above 2,000 ft. altitude.	3/4" Hot water boiler feed 35 PSI minimum 60 PSI maximum	3/4" Boiler drain valve	Electric low water fuel shut-off and water supply. 25 watts for 210,000 BTU Steam Generator (Does not apply to 100,000 and 150,000 BTU Steam Generators).	Wiring Diagram --Gas Fired-- Steam Generators with Pilot ignition (with 4 terminal gas valve, used prior to 10 January, 1972).

**CLEVELAND RANGE, INC., 1333 EAST 179th ST., CLEVELAND, OHIO 44110**  
 Manufacturer reserves right of design improvement or modification, as warranted. 1286

LITHO IN U.S.A.

**WIRING DIAGRAM FOR 100,000 and 150,000 BTU STEAM GENERATORS, WITH PILOT IGNITION,  
WITH MECHANICAL LOW-WATER FUEL CUTOFF,  
WITH AND WITHOUT SAFETY RESET CIRCUIT**

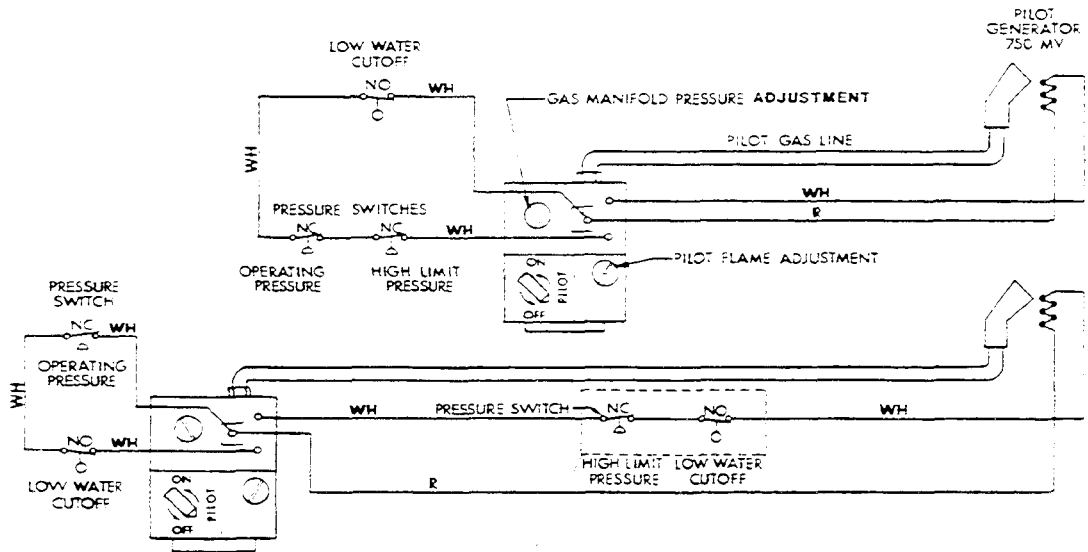

**WITH SAFETY RESET CIRCUIT**

**WIRING DIAGRAM FOR 210,000 and 160,000/200,000 and 250,000/300,000 BTU  
STEAM GENERATORS, WITH PILOT IGNITION, WITH ELECTRICAL LOW-WATER FUEL CUTOFF,  
WITH MANUAL SAFETY RESET CIRCUIT**

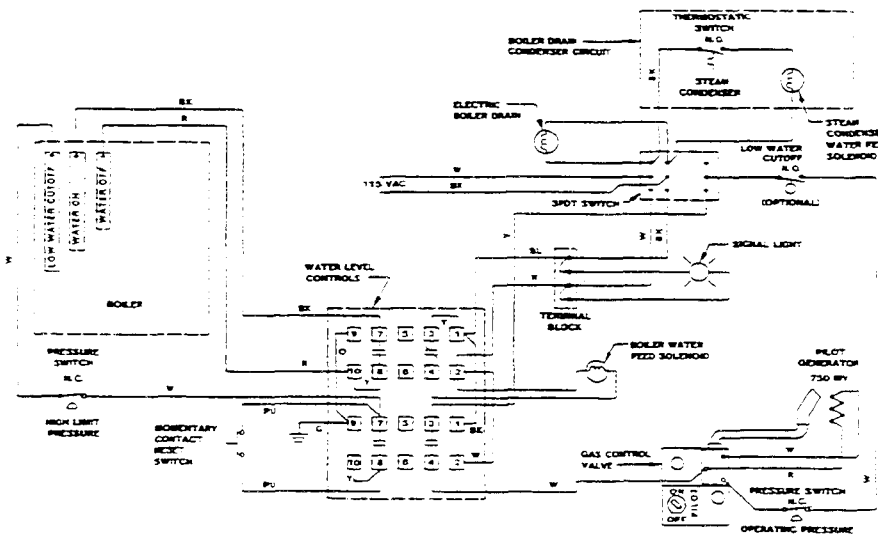

**GAS**

3/4" IPS for 220,000 BTU or less.  
1" IPS for 240,000 BTU or more  
supply pressure.  
4" W.C. min. 14" W.C. max.  
Manufacturer must be notified if unit  
will be used above 2,000 ft altitude.

**WATER**

35 PSI minimum  
60 PSI maximum  
1/4" IPS hot water for steam  
generator 1/4" IPS cold  
water for condenser.

**DRAINAGE**

1 1/2" IPS common drain  
Do not connect any other  
unit(s) to this drain.

**DRAINAGE CONTROL T15V-1**

25 watts boiler control for electric  
low water fuel shut-off and water  
supply. (Does not apply to  
100,000/ 150,000 BTU Steam  
Generators with mechanical low  
water fuel shut-off and water  
supply).

Wiring Diagram  
—Gas Fired—  
Steam Generators  
with Pilot Ignition  
(with 3 terminal gas valve, used after  
to January, 1972).

**CLEVELAND RANGE, INC., 1333 EAST 179th ST., CLEVELAND, OHIO 44110**  
Manufacturer reserves right of design improvement or modification, as warranted.





## STEAM COIL GENERATOR (BOILER) ASSEMBLY WITH VARIOUS CONTROL OPTIONS (INCLUDES BOILERS EQUIPPED WITH 0, 1, or 3 PROBES)

REFERENCE NUMBER	PART NUMBER	DESCRIPTION	REFERENCE PART NUMBER	PART NUMBER	DESCRIPTION
1	43700	Steam coil boiler shell with legs, sight gauge, water regulator, steam coil, one corrosion resistor, hand hole plate assembly. (For use with mechanical pressure regulating valve for controlling the steam supply.)	19	52453*	Probe extension (for use only with single probe boilers)
	43782	Steam coil boiler shell (43700) above, also including one probe and extension with cover box, for electric operation of the steam supply controls (solenoid valve in lieu of the mechanical pressure regulating valve).	20	101468	Probe extension set (3) (for use only with three probe boilers)
	439881	Steam coil boiler shell only, with legs and hand hole plate assembly. (Equipped with 3 probe holes for use with electrically controlled water and steam supplies)	21	43895	Corrosion resistor (not used with 3 probe boilers)
	43989	Steam coil boiler shell (43988) above, also including sight gauge, steam coil, 3 probes and extensions with cover box (for use with electrically controlled water and steam supplies).	22	222 00	3/4" Pressure reducing valve - 30 to 50 psi (optional)
			23	07169	Pressure gauge, bottom mount (0-100 psi)
			24	03277	3/4" Ball valve
			25	22151	3/4" Steam control valve
			26	22193*	3/4" Steam solenoid valve
			27	22140	Air vent
			28	100075	Safety valve - 50 psi
			29	22106	1/2" Solenoid valve, boiler auto blowdown 115 volt (optional)
2	1 00636	Hand hole plate assembly, incl. bar, nut, and gasket	30	22112	Water shut-off angle valve
	1 6545	Hand hole plate only	31	19872	3/4" Line strainer
3	07116	Hand hole gasket	32	20555	3/4" Bucket trap
4	40401	Steam coil assembly	33	03276	1/4" Ball valve
5	14612	1 1/4" Brass locknut	34	22102	1/4" Check valve
6	23135	3 1/4" Square flat washer	35	44095**	1/2" Water teed solenoid valve
7	14611	1 1/4" Steel locknut gauge set with glass	36	19870	1/4" Line strainer
	07108	Fibre Washer (2 required)	37	07173	Pressure gauge, rear mount, 0-30 psi, 2 1/2"
	23132	Gauge Glass Washer (2 required)		07168	Pressure gauge, rear mount, 0-30 psi, 2" (Pressure Steamers only)
9	07301	Glass only - 10 1/2" long	38	19944*	On-off power switch, 115/220 volt, DPST
10	43720	Water regulator valve assembly (used before April, 1984)	39	19968*	Reset switch
			40	12161*	Signal light, 115/220 volt, 1"
11	06300	Float only		12169*	Signal light, 115/220 volt, 1/2" (Pressure Steamers only)
12	43740	Float arm and block assembly	41	19947*	Pressure switch
13	100655	Float pivot bracket	42	03514*	Low water cut-off relay -115 volt (1C1D0).
14	23130	Sealing washer	43	03504**	Water control relay, 115 volt (1D1D0)
15		Float plunger assembly	44	19020***	3/4" Moisture separate (ball float trap)
16	16833	Plunger disc	45	19945*-	Float switch with gasket - low water cut-off (California only)
17	43724	Water regulator valve sub-assembly (seat)			
1 3	40462*	Probe with lockwasher and screw			

\*Required for electric steam control and electric low water cut-off safety circuit: Through November 1982, these components were used in lieu of the #22151 steam control valve as standard equipment on all 24" and 60" wide cabinets and all California units, but optional on 36" and 42" wide cabinets. After November 1982, the #22151 was not used and the electric controls became standard equipment on all steam coil generators.

\*\*Required for electric (solenoid valve) water fill, used in lieu of the #43720 water regulator valve, beginning April 1984

\*\*\*Optional, if steam supply is wet.

CLEVELAND RANGE, INC., 1333 EAST 179th ST., CLEVELAND, OHIO 44110  
Manufacturer reserves right of design improvement or modification, as warranted

## STEAM COIL WIRING DIAGRAM

We are aware of the poor quality and are making arrangements with the Manufacturer for a better copy.

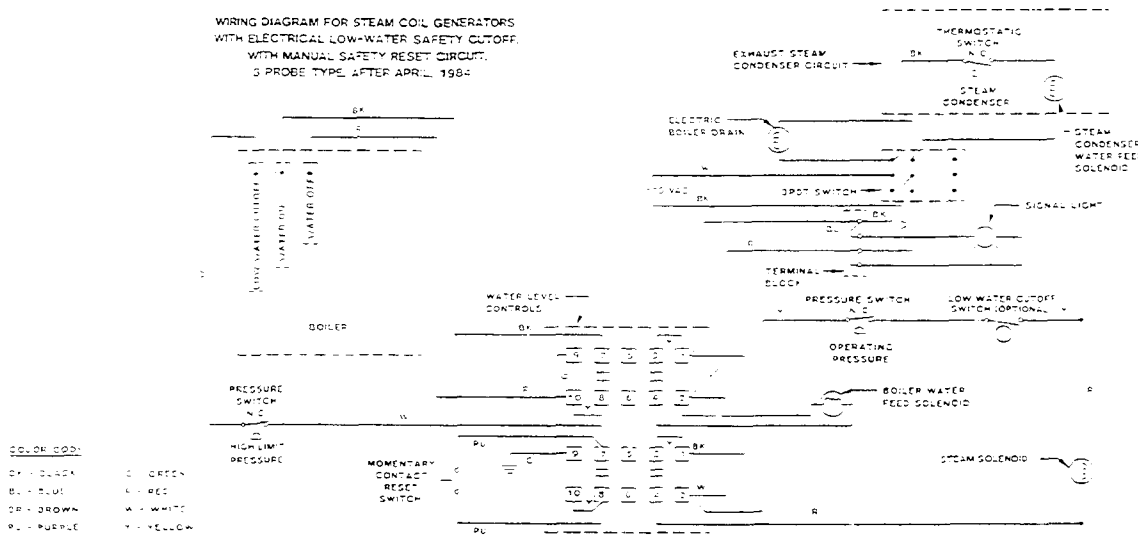

### HOW THE ELECTRIC LOW WATER SAFETY SHUT-OFF OPERATES ON STEAM COIL (ELECTRIC OPERATED) STEAM GENERATORS

#### Operation — Low Water Safety Shut-Off

When Switch S is closed the following operations occur

1. The primary circuit of Transformer T is energized.
2. When the water level reaches the low water safety cutout probe extension and the momentary reset switch is manually closed, Relay Coil RC is energized.
3. When Relay Coil RC is energized, the normally open contacts close, completing the low water safety circuit through Contacts 7 and 8, and completing the circuit through Contacts 3 and 4, energizing Solenoid SV2, allowing steam to flow into the boiler's steam coil.

If the water level drops below the Low Water Safety Cutout probe extension, the following occurs:

1. The secondary circuit of Transformer T is broken and the Relay Coil RC is de-energized. Contacts 7 and 8 and 3 and 4 open, breaking the circuits to Solenoid SV2, thereby shutting off the flow of steam to the boiler's steam coil.

The steam Solenoid SV2 will not operate until water level in the boiler is normal and the reset switch is operated.

#### Operation — Boiler Drain Condenser

To activate the Boiler Drain Condenser System, close Switch S by placing toggle in the down position.

To drain the boiler, open the boiler drain ball valve. The heat from the boiler drain water will close the normally open Thermal Switch TS and energize the condenser Solenoid Valve SV3. To deactivate the Boiler Drain Condenser System, open Switch S by moving toggle to the center off position.

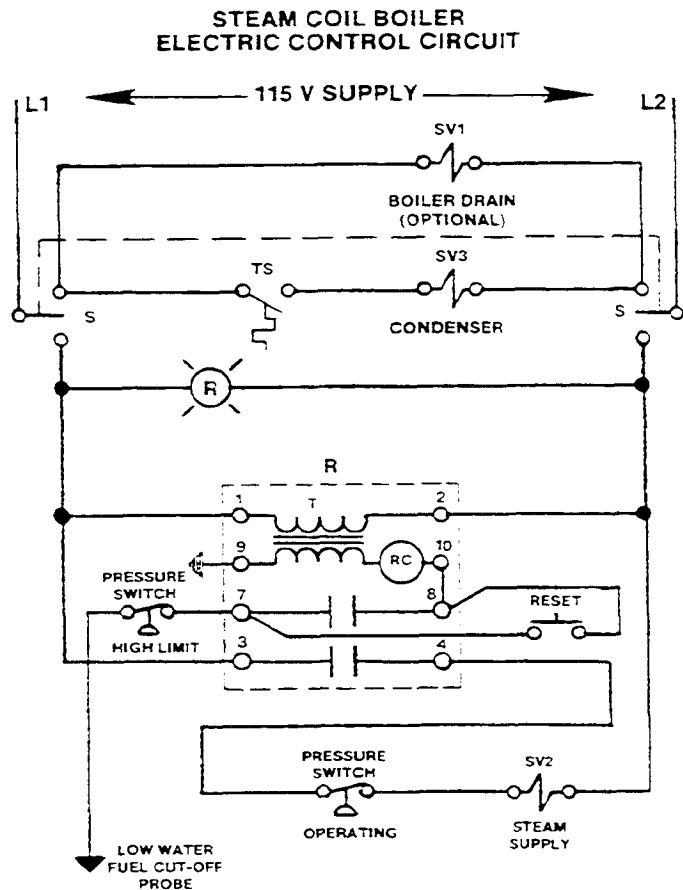

## SERVICING INSTRUCTIONS — MECHANICAL WATER FILL FOR STEAM GENERATOR

The water level in the sight gauge should normally be about 2/3 full. If it is not, then (1) the water valve may be scaled up or (2) the water valve plunger disc is in need of replacement or (3) the adjusting screw at the top of the valve plunger is set incorrectly or (4) the float needs to be replaced.

**WARNING: Steam under pressure may cause serious injury and bodily harm when it is accidentally or carelessly released. Therefore, service of the steam generator should only be performed by trained and experienced personnel, thoroughly familiar with servicing steam generators.**

To service the water valve:

1. Turn off all utilities and fuel to steam generator. Drain steam generator

**CAUTION: Never work on the steam generator while it is hot or pressurized.**

2. Remove hand hole plate from steam generator. Refer to separate data sheet for proper procedures and cautions.
3. (Inside the steam generator as shown on the diagram). Remove the float arm pivot screw. Disengage float arm assembly.
4. Lift out valve plunger disc and install new plunger disc.
5. Remove scale from valve seat and other internal valve surfaces.
6. Re-insert plunger in valve.
7. Install float arm assembly and check the adjustment—Float travel should be approximately 6 inches.
8. To increase the travel, turn adjusting screw clockwise. To decrease, reverse.
9. Re-install hand hole plate, never applying more than 15 ft./lbs. torque to the nut. The hand hole plate should be cleaned and examined every time it is removed. If the hand hole plate is chipped or cracked, or over three years old, install a new one. Because continuous use and possible abuse cause metal fatigue which weakens the hand hole plate, a new one should be installed at least every three years. Replace the gasket at least once a year—or sooner if it is cracked or hardened. Replace the hand hole gasket when re-installing the hand hole plate.

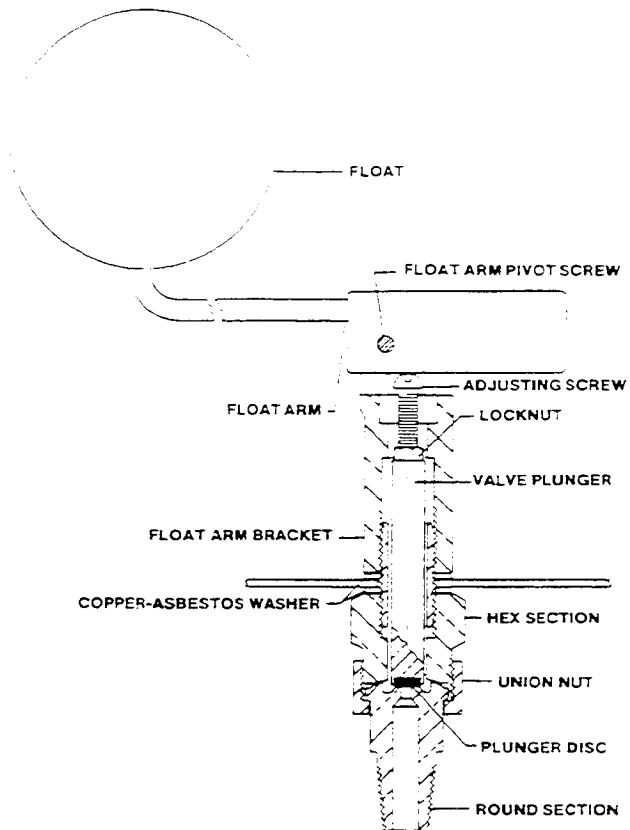

10. Close steam generator drain valve. Turn on utilities and fuel.
11. Check the water level. Proper level in the sight gauge is about 2/3 full.
12. Start up and observe steam generator long enough to see that it is operating properly.
13. After the valve plunger disc is installed, order more to have spares on hand at all times.

If hard water scale created the problem, the use of more corrosion resistors or more frequent replacement of them is required. Refer to separate datasheets for maintenance instructions pertaining to scale problems.

**CLEVELAND/ALCO, 1333 EAST 179th ST., CLEVELAND, OHIO 44110**  
Manufacturer reserves right of design improvement or modification, as warranted.