

# Cleveland Range

---

---

## REPAIR MANUAL

*Model No.* 42CKEM24/36/48  
42CKGM200/250/300  
42CKDM  
42CKSM

---

---

Cleveland Range, Inc.

**UNITED STATES**

1333 East 179th St  
Cleveland, Ohio 44110  
Phone:(216 )481-4900 • FAX: (216) 481-3782

**CANADA**

Garland Commercial Ranges • 1777 Kamato Rd.  
Mississauga, Ontario CN L4W 1X4  
Phone: (416) 624-0260 • FAX: (416) 624-0623

# Installation, Use and Care Instructions

## Convection Steamer

### INSTALLATION INSTALLATION SAFETY

#### WARNING

Installation of this equipment must be accomplished by qualified installation personnel, working to all applicable local and national codes. Improper installation at this product could cause injury or damage.

**DO NOT** store or use gasoline or other flammable vapors and liquids in the vicinity of this or any other appliance.

The **flooring** that **will** be directly under the boiler must also be made of a noncombustible material.

Cleveland Range equipment is designed and built to comply with applicable standards for manufacturers. Included among those certification agencies which have approved the safety of the equipment design construction are: UL, A.G.A., NSF, ASME, CSA, CGA, and others.

Cleveland Range equipment is designed and certified for safe operation only when permanently installed in accordance with local and/or national codes. Many local codes exist and it is this responsibility of the owner and installer to comply with these codes.

In no event shall Cleveland Range assume any liability for consequential damage or injury resulting from installations which are not in strict compliance with our installation instructions. Specifically, Cleveland Range will not assume any liability for damage or injury resulting from improper installation of equipment including, but not limited to, temporary or mobile installations.

### INSTALLATION INSTRUCTIONS

1. These instructions must be retained by the owner/user for future reference. Gas-fired boilers are only to be installed in noncombustible areas that have provisions for adequate air supply. The term "boiler" will be used synonymously with "steam generator"
2. Position: For proper operation and drainage, the equipment must be level. It should be placed next to an open floor drain. **DO NOT POSITION THE UNIT DIRECTLY ABOVE THE FLOOR DRAIN.** Observe all clearance requirements to provide air supply for proper operation, as well as sufficient clearance for servicing. The surrounding area must be free and clear of combustibles. Dimensions and clearance specifications are shown on the specification sheet.
3. Install in accordance with local codes and/or the National Electric Code ANSI/NFPA No. 70-1987. Installation in Canada must be in accordance with the Canadian Electrical Code CSA Standard C22.1. Equipment that is connected to electricity must be grounded by the installer. A wiring diagram is provided inside the base cabinet.

#### WARNING

INJURY TO PERSONNEL AND EQUIPMENT DAMAGE may result from **an** improper drain connection.

4. The drain line outlet discharges exhaust steam and hot condensate. Connect 1-1/2-inch IPS piping (or larger) to extend the drain line to a nearby open floor drain. Up to two elbows and six feet of 1-1/2-inch IPS (or larger) extension pipe should be connected to the drain termination. Drain piping extended six to twelve feet or using three elbows, should be increased to 2-inch IPS. No more than two pieces of Cleveland Range equipment should be connected to one common drain line. The maximum length of extension from the drain termination should not exceed six feet and use no more than two elbows. The extension piping must have a gravity flow and vent freely to the air. This drain outlet must be free-vented to avoid the creation of back pressure at the steamer cooking compartments. To ensure a vented drain line, **DO NOT, UNDER ANY CIRCUMSTANCES, CONNECT THE DRAIN OUTLET DIRECTLY TO THE FLOOR DRAIN OR SEWER LINE.** Do not run the drain line discharge into PVC drain piping or any other drain piping material not capable of sustaining 180 F operation.

**NOTE** Direct steam connected pressure steamers do not require a cold water connection, and therefore steps 5 and 6 do not apply. Refer directly to step 7. A kettle fin faucet, if so equipped, requires a hot and/or cold water connection. The data contained in step 5 for cold water also applies to hot water.

5. Connect COLD water supply plumbing to the line strainer. (Never connect hot water to the boiler-water fill line strainer.) Constant flow pressure must be maintained between 35 and 60 psi, and not experience a pressure drop below 35 psi when other appliances are used. If the water pressure exceeds 60 psi, a pressure reducing valve must be installed in the water supply plumbing. To reduce the water pressure 10 less than 60 psi. Locations and pressure data are shown on the specification sheet. 1/4-inch IPS plumbing is sufficient for water supply lines up to 20 feet in length, but water supply lines longer than 20 feet should be at least 3/8-inch IPS. Flush water supply lines thoroughly before connecting them to the unit. Use water which is low in total dissolved solids content and low in gas content to prevent internal scaling, pitting and corrosion of the steam generator, and carry-over of minerals into the steam. Water which is fit to drink, can still contain highly detrimental impurities.

**NOTE:** If equipped with a kettle and kettle **water** fin swing spout, 3/8-inch (10mm) **not** and/or **cold** water connections) will **be** required at the **swing** spout valve.

6. Turn on the cold water supply to the unit. Ensure that the manual water valve, inside this base cabinet, is open.

# Installation, Use and Care Instructions

## Convection Steamer

---

7. Connect the primary fuel supply in accordance with the following instructions. *Location* and other data are shown on the specifications sheet.

For Gas-Fired Steam Generators: Post in a prominent location, instructions to be followed in the event the user smells gas. This information shall be obtained by consulting the local gas supplier. Install a sediment trap (drip leg) in the gas supply line then connect gas supply piping to the boiler gas valve piping. GAS-FIRED EQUIPMENT IS DESIGNED FOR INSTALLATION ONLY IN NON-COMBUSTIBLE LOCATIONS. THIS INCLUDES THE FLOORING THAT WILL BE DIRECTLY UNDER THE EQUIPMENT. Location, plumbing size, and pressure data are shown on the specification sheet. Boilers rated less than 225,000 BTU require 3/4-inch IPS gas supply piping, and boilers rated at 225,000 BTU or more require 1-inch IPS gas supply piping. Natural gas pressure must be between 4"-14" water column, and L.P. gas supply pressure must be between 12" - 14" water column. NEVER EXCEED 14" WATER COLUMN (1/2 psi) GAS PRESSURE. If the gas supply pressure exceeds 14" water column, a pressure regulating valve must be installed in the gas supply plumbing to reduce the gas pressure to less than 14" water column. Installation must be in accordance with local codes, or in the absence of local codes, with the National Fuel Gas Code, ANSI 2223.1 1984. Installation in Canada must be in accordance with Installation codes for Gas Burning Appliances and Equipment B149.1 and B149.2 Use a gas pipe joint compound which is resistant to LP gas. Turn the gas valve control knob to ON (the word "ON" on the knob will be opposite the index on the valve's body). Test all pipe joints for leaks with soap and water solution. Never obstruct the flow of combustion and ventilation air. Observe all clearance requirements to provide adequate air openings into the combustion chamber. The appliance and its individual shut-off valve must be disconnected from the gas supply piping system during any pressure testing of that system at test pressures in excess of 14" water column (1/2 psi or 3.45 kPa). The appliance must be isolated from the gas supply piping system at test pressures equal to or less than 14" water column (1/2 psi or 3.45 kPa). A permanent 115 volt electrical connection is required at the junction box. The junction box location is shown on the specification sheet. The unit must be electrically grounded by the installer.

For Electronic Powered Steam Generators: Connect electric power: location and data are shown on the specifications sheet. Provide connection as required by the unit; either directly to the single contactor, or to the terminal block (when equipped with multiple contactors). Electric supply must match power requirements specified on the data plate inside the base cabinet. The copper wiring must be adequate to carry the required current at the rated voltage. A separate fused disconnect switch must be supplied and installed. The unit must be electrically grounded by the installer.

For Steam Con Steam Generators: Connect Steam supply piping to the input side of the steam coil. Location and pressure data are shown on the specifications sheet. Incoming steam pressure must be regulated between 35 and 45 psi. A 3/4-inch strainer, equipped with a 20 mesh stainless steel screen must be supplied and installed at the incoming steam connection point. Flush the steam line thoroughly before connecting it to the boiler. To ensure an adequate volume of steam, the branch steam supply line must be 3/4-inch IPS minimum. Connect the inverted **bucket trap to the outlet end of the steam coil.** Fill the trap with **water** before installing it. A permanent 115 volt electrical connection is required at the junction box. The junction **box location** is shown on the specification sheet. The **unit must be electrically grounded by the installer.**

For Direct-Steam Connected Steamers/Kettles: Connect steam supply piping to the input side of the line strainer. Location and pressure data are shown on the specification sheet. Flush the steam line thoroughly before connecting it to the steamer. To ensure adequate of steam the branch steam supply line must be 3/4-inch IPS minimum (Direct-steam-connected kettles require 1/2-inch require IPS pipe if the kettle total capacity is 20 gallons or less, and 3/4-inch IPS pipe if the total capacity exceeds 20 gallons.) A permanent 115 electrical connection is required at **the junction box.** The **junction box location is shown on the specification sheet.** The **unit must be electrically grounded by the installer.**

### Installation Checks

Proper **operation** of the Cleveland Convection Steamer is dependent **upon** proper installation. After the steamer has been installed. A few quick checks could **save** unnecessary service calls.

1. The unit must be level
2. The Convection Steamer requires a cold water connection for proper, efficient operation. **DO NOT USE HOT WATER**. The cold water must be connected to the line strainer located at the front lower-right of the steamer base
3. Check that the manual water supply valve is open
4. Check all water supply lines and valves for leaks
5. Check that the water supply pressure and water quality **meet** the requirements **of installation** paragraph 5
6. On electric units, verify that the supply voltage meets the voltage requirements on the rating plate inside the base cabinet, and the voltage shown on the packing slip. Verify that the unit is protected with a separate fused disconnect, and is properly grounded in accordance with the National Electric Code
7. On gas, steam con, and direct-steam-connected units, verify that there is a 115 Volt connection at the handi-box located on the left side of the base at the bottom front.

# Installation, Use and Care Instructions

## Convection Steamer

8. On steam coil units, the incoming steam pressure *must* be 35 to 50 psi. Less than 35 psi will not effectively operate the unit. Pressure in excess of 50 psi must be reduced (with a pressure reducing valve) to 35 to 50 psi.

**WARNING**  
**INJURY TO PERSONNEL AND EQUIPMENT DAMAGE**  
**may result from an improper drain connection.**

9. Check that the drain lines meet the installation requirements specified in installation paragraph 4.
10. After completing checks 1 through 9, and correcting any deficiencies, refer to the Start-Up and Preheat and Preheat instructions in the Operation section. Verify that the unit operates properly, and make checks 11 and 12.
11. Check to ensure that the water in the boiler sight glass automatically says about 1/3 full when the boiler is started.

12. **Check to ensure that the steam pressure gage registers 110 psi.**
- The steam pressure is factory-adjusted to provide the proper pressure. In some cases, however, the factory set- may shift down due to shaking and resetting will be required after installation. Proper adjustments and maintenance procedures are detailed on a separate data sheet entitled "Steam Pressure Adjustments." Adjustments be made only by qualified service personnel. The factory pressure settings shown in the accompanying chart **should never be exceeded**.

### Gage Pressure Reading with No Steam Flow\* (Static Pressure)

#### Self-Contained Steam Generator Steam, Gas or Electric

Operating Pressure Switch      **10 psi**  
 High Limit Safety Pressure Switch  
 15psi

#### Self-Contained Steam Coil Generator

Operating Pressure Switch    10 psi High Limit  
 Safety Pressure Switch      15 psi Steam  
 Supply Pressure Range      35-  
 45 psi

#### Direct-Connect (to House Steam Supply)

Steamer Pressure Reducing Valve    10 psi Steam  
 Supply Pressure Range            15-45 psi

•with or without kettle

## OPERATION

Operation of the Cleveland Range Convection Steamer is very **easy**. Each operator should read and understand the following procedures to effectively start, operate, and shut down the **steamer** each **day**. The owner(s) and operator(s) of this equipment should be aware that live steam can cause serious injuries, and pay particular attention to the WARNINGS in this text. These instructions are to be retained by the owners) and operator(s)) for future reference.

### Controls and Control Panels

There are two steam generator control arrangements and two steamer compartment control panels available for Cleveland Range Convection Steamers. The steam generator controls are illustrated. The steamer compartment control panels are illustrated in Figures 2 and 3. Compare these figures with the equipment supplied, and identify which control and panel combinations apply.

### Steam Generator Controls

The steam generator controls are located on the front face of the steamer base unit. The switches are to the left of the pressure gage, as illustrated in Figure 1. Most Cleveland Range Convection Steamers have steam generator built into the base unit which supplies steam to the cooking compartments. However, an external steam supply may also be used. Units with a built-in boiler have both the **POWER rocker switch** and the **STEAM momentary switch** next to the pressure gage. Units with an external steam supply have the **POWER rocker switch** only. They do not have the **STEAM** momentary switch.

### Steamer Compartment Control Panels

Figure 2 illustrates the standard electronic controls: the Key Pad Control Panel. This panel has a rocker switch, a key pad, and a digital timer. Figure 3 illustrates the optional electromechanical controls: the Dial Timer Control Panel. This panel has a rocker switch and dial timer. Steamer functions are the same for both the standard and optional panel configurations. Operating details are slightly different especially when setting the automatic operating time. For clarity, two sets of instructions are provided for cooking operations.

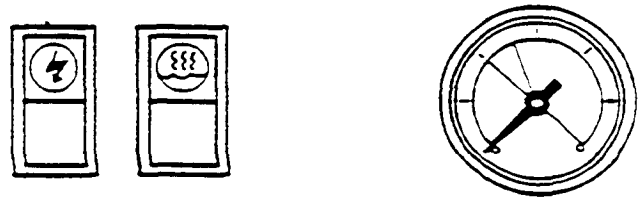

Figure 1. Steam Generator Controls

## Installation, Use and Care Instructions Convection Steamer

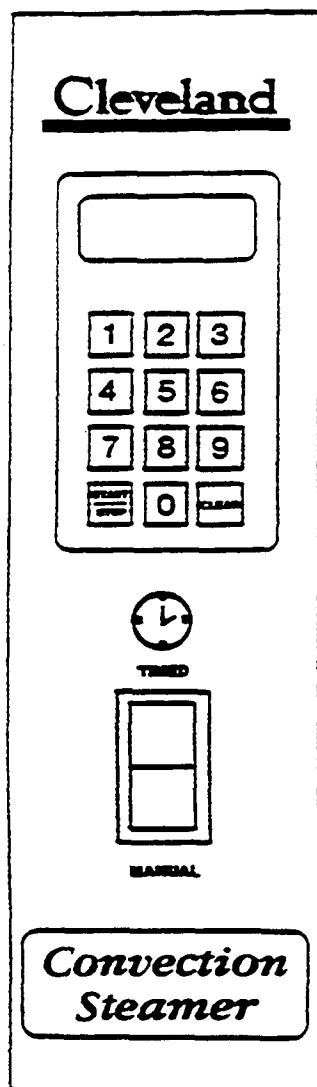

Figure 2. Key Pad Control Panel

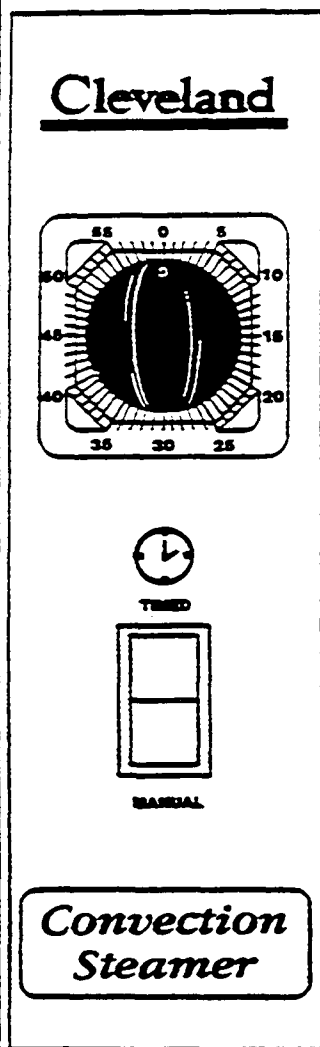

Figure 3. Dial Timer Control Panel

### Start-up and Preheat

#### WARNING

Do not attempt to start or operate the Convection Steamer during a power failure are not energized, and serious injury to personnel or damage to equipment may result.

1. Inspect the steamer. Check: the cooking compartments 10 ensure that the steam tubes and drain screens are in place and secure. Check inside the steamer base cabinet 10 ensure that the manual drain valve is closed and the manual water supply valve is open.

2. Start the steam supply. The steam supply is either an integral steam generator (boiler) built into the base unit. or external steam supply.

- For units without a built-in boiler, refer to the startup procedures for the external steam supply and be sure it is running **properly**. **As soon as** the pressure gage on the Convection Steamer registers 10 psi. steamer preheating may begin. Skip the remainder of step 2 and begin step 3.
- For units with a built-in boiler. fin the boiler with water and start the steam generator as described in steps a. through d. below

- a- Press the ON end of the POWER on-off rocker switch located next 10 the steam pressure gage (Figure 1). The red indicator light in the POWER rocker switch turns on and the steam generator begins to fill with water. This takes about 5 minutes
- b. When the-water level in the steam generator reaches a safe operating level, the amber light in the STEAM momentary switch turns on. Whenever the amber light is on, the heaters, steam supply or burners arc off. and no steam is being generated. The energy source (electric, gas. etc..) cannot be activated until the boiler **contains sufficient water indicated by The** amber light
- c. Press the STEAM momentary switch to produce steam in the boiler. This activates the energy source (electric heaters, gas burners or steam solenoid valve) and the amber light turns off.  
The STEAM switch must be pressed to re-start the steamer after it is shut off for any reason (including a brief power interruption). No attempt should be made to operate the equipment during a power failure.

#### NOTE: For steamers with built-in gas-fired boiler:

If the burners fail 10 ignite m four seconds, a safety circuit de- energizes the system. In this event, toggle the POWER rocker switch to the OFF position and back to the ON position. The amber light in the STEAM momentary switch lights. Wait five minutes, then press the STEAM momentary switch to start the burner ignition cycle once again.

- d. About 20 minutes after starting the boiler in step c, the
- e. steam pressure guage on the unit base should register 10 psi.
3. Preheat the Convection Steamer cooking compartments. For accurate, efficient **cooking** times, the cooking compartments should be preheated during startup.

**NOTE: With a steamer/kettle combination, if both must be used at the same time, always heat the kettle first, When kettle contents begins to simmer, and steam pressure returns, the steamer compartments may be preheated.**

- a- **Close the compartment door by gently swinging it shut.**
- b. Refer to timer setting instructions under Automatic Operation for the appropriate control panel **Set** the

# Installation, Use and Care Instructions

## Convection Steamer

timer for each compartment to one minute, and start the cooking cycles. Steaming begins in each compartment.

**NOTE:** On Convection Steamers equipped with electronic key pad controls panels, the timer does not begin counting down until the cooking compartment reaches operating temperature. This may take 2 or 3 minutes if the steamer has not been operating.

- c. Steaming continues for the set one minute. When the preheating is complete, the steam automatically shuts off and a 3-second alarm sounds. The Convection Steamer is ready for cooking operations.

### COOKING OPERATIONS

The control panels mounted on the cooking compartments regulate cooking operations. Although cooking operations are similar for all Convection Steamers, regardless of control panel configuration, separate instructions are provided for each control panel type.

#### Cooking Operations for

##### The Key Pad Control

##### Panel

The electronic key pad control panel is illustrated in Figure 2.

The Cleveland Range Convection Steamer has two cooking modes: Manual and Automatic. The Manual Mode provides continuous steaming and is turned on and off by the MANUAL/TIMED rocker switch. The Automatic Mode monitors cooking time and temperature to provide accurate, efficient, uniform steam cooking.

**NOTE:** Whether using timed or manual cooking mode, optimum steam heat transfer, and therefore a higher quality food product, is achieved when shallow, perforated, uncovered pans are used.

**WARNING** LIVE STEAM may cause severe burns. Use extreme caution when opening the steamer door. Turn face away from the steamer when first opening the door. Do not look into the cooking compartment until steam has cleared. **KEEP HANDS OUT OF THE COOKING COMPARTMENT TO PREVENT BURNS.**

##### Manual Cooking Operation - Key Pad Controls

Use manual mode for a continuous supply of steam for long periods, or if the required cooking time is unknown and frequent inspection is required.

1. Place the pan(s) of food into the cooking compartment.
2. To START the flow of steam, press the MANUAL end of the MANUAL/TIMED rocker switch, located below the timer. Steam immediately starts flowing into the cooking compartment.

3. If food inspection is required during steaming, refer to the LIVE STEAM WARNING above. Use extreme caution when opening the steamer door during steaming operations.

4. Although the timer cannot turn the steam off in manual mode it can be used as a conventional cooking timer. Refer to the timer setting instructions under Automatic Operation and set the timer. The timer will count down the set period and sound the buzzer, but IT WILL NOT TURN OFF THE STEAM-AFTER THE ALARM SOUNDS.

5. To STOP the flow of steam, press the Timed end of the MANUAL/TIMED rocker switch. Steam stops flowing into the cooking compartment.

##### Automatic Cooking Operation - Key Pad Controls

Each Convection Steamer cooking compartment is equipped with an independent electronic digital timer, which has a maximum setting of 99 minutes and 99 seconds. Each timer is connected to a temperature sensing device in the cooking compartment. THE SENSOR CIRCUIT ALLOWS THE TIMER TO COUNTDOWN ONLY WHEN THE COOKING COMPARTMENT IS AT THE PROPER COOKING TEMPERATURE. This assures uniformity in the cooking times as the timer automatically compensates for food product defrosting and/or heat-up time.

1. Place the pan(s) of food into the cooking compartment
2. Clear and reset the timer. The timer can be set only when the COOKING TIME display is clear. Press the CLEAR key on the number pad to zero the timer.
3. Set the Desired Cooking Time. The cooking time display contains four digits. **The left two** digits are minutes, and the right two digits are seconds. The display 12:34 is set for 12 minutes and 34 seconds.
  - a. To set the cooking time: change the required cooking time to minutes and seconds, press the number keys for the minutes and then press the number keys for the seconds. If the cooking time 99 seconds or less, only press the number keys for seconds.
  - b. Example 1. To set the timer for 1 hour and 15 minutes: Change 1 hour (60min) and 15 minutes to 75 minutes. Press the following number keys in sequence: 7500. The display will read 75:00 when properly set for 1 hour and 15 minutes.
  - c. Example 2. To clear the time numbers set in example 1. press the CLEAR key on the number pad. The display returns to 00:00.
  - d. Example 3. To set the timer for 1-5 minutes: Change the time to 1 minute and 30 seconds. Press the following number keys in sequence: 1,3,0. The display will read 01:30, when set for 1.5 minutes. All seconds method: Change the 1.5 minutes to 90 seconds and press 9 0. The display will read 00:90, when set for 1.5 minutes.

# Installation, Use and Care Instructions

## Convection Steamer

4. Press the START/STOP key to start the timer. When the START/STOP key is pressed, steam enters the cooking compartment.
  - a. **THE TIMER WILL BEGIN TO COUNT DOWN ONLY AFTER THE COOKING COMPARTMENT REACHES PROPER COOKING TEMPERATURE.**  
The timer automatically delays to compensate for defrosting and/or food product heat-up time.
  - b. For example, a timer setting of 10 minutes may in fact take 11 or 12 minutes for the timer to count down and the alarm to sound. This is normal. Heating the compartment and food to cooking temperature uses the additional time.
  - c. To stop or reset the timer, press and hold the START/STOP key. The cooking one display returns to the last time setting.
    - To restart the same time, press the START/STOP key.
    - To set a new time press the CLEAR key, and set the new time.
5. When the timer counts down to zero, an alarm sounds continuously. Press the START/STOP key to silence the alarm. The cooking time display returns to the last time setting. Either run this same setting again or clear and reset the timer.
6. Example 4. To **cook** two 14 minutes cycles: Press the CLEAR key to clear the timer. Press the following number keys in sequence: 1,4,0,0. The display shows 14:00. Press the START/STOP key to start the timer. When the display counts down to zero, the alarm sounds. Press the START/STOP key, and the display returns to 14:00. Press the START/STOP key to start the second 14 minute cycle.

### Cooking Operations for

#### The Dial Timer Control Panel

The dial timer control panel is illustrated in Figure 3.

The Cleveland Convection Steamer has two cooking modes:

Manual and Automatic. The Manual Mode provides continuous steaming and is turned on and off by the MANUAL/TIMED rocker switch. The Automatic Mode monitors cooking time to provide accurate, efficient, steam cooking.

**NOTE:** Whether using timed or manual cooking modes, optimum steam heat transfer, and therefore a higher quality food product, is achieved when shallow, perforated, uncovered pans are used.

#### **WARNING:**

LIVE STEAM may cause severe burns. Use extreme caution when opening the steamer door. Turn face away from the steamer when first opening the door. Do not look into the cooking compartment until steam has cleared. **KEEP HANDS OUT OF THE COOKING COMPARTMENT TO PREVENT BURNS.**

### **Manual Cooking Operation - Dial Timer Controls**

Use Manual mode for a continuous supply of steam for periods longer than the timer limits (99 minutes), or if the required cooking time is unknown and frequent inspection is required.

1. Place the pan(s) of food into the cooking compartment.
2. To START the flow of steam, press the MANUAL end of the MANUAL/TIMED rocker switch, located below the timer.
3. If food inspection is required during steaming, refer to the LIVE STEAM WARNING above. Use extreme caution when opening the steamer door during steaming operations.
4. Although the timer cannot turn the steam off in manual mode it can be used **as** a conventional cooking timer. Refer to the timer setting instructions under Automatic Operation and set the timer. The timer will count down the **set** period and sound the buzzer, but **IT WILL NOT TURN OFF THE STEAM AFTER THE ALARM SOUNDS.**
5. To STOP the **flow** of steam, press the Timed end of the MANUAL/TIMED rocker switch.

### **Automatic Cooking Operation**

#### Dial Timer Controls

Each Convection Steamer cooking compartment is equipped with an independent dial timer. This timer controls the cooking compartment steaming cycle. Use automatic mode when an exact cooking time is required. Steam cooking begins when the timer is set, and automatically stops when the timer counts down the set period.

1. Check that the MANUAL/TIMED rocker switch is in the TIMED position. If it is not, press the TIMED end of the MANUAL/TIMED rocker switch.
2. Place the pan(s) of food into the cooking compartment.
3. Set the Desired Cooking Time. Turn the dial until it points **to** the desired cooking time. When the dial timer is set, steam enters the cooking compartment.
4. When the timer counts down to zero, an alarm sounds for 4 seconds, and steam flow into the cooking compartment stops.

### **Boiler Shutdown**

The red-lighted power switch must **be** shut off for 3 minutes a minimum of once every 8 hours to automatically drain highly mineralized water from the boiler, which reduces the formation of scale. See Step 1 in CARE AND CLEANING instructions, which follow.

# Installation, Use and Care Instructions

## Convection Steamer

---

### CARE AND CLEANING

The Cleveland Convection Steamer must be cleaned regularly to maintain its fast, efficient cooking performance, and to ensure its continued safe, reliable operation.

1. The boiler must be drained (Blowdown) after a maximum of 8 hours of use. If the boiler feedwater contains more than 60 parts per million of total dissolved solids, the boiler must have a blowdown more often, the frequency depending upon the mineral content of the feedwater. Blowdown means the boiler must be drained under pressure.

THE BOILER BLOWDOWN IS PERFORMED BY SIMPLY SHUTTING OFF THE STEAMER'S RED-LIGHTED POWER SWITCH WHILE THE BOILER IS AT NORMAL 10 PSI OPERATING PRESSURE. WHEN THE BOTTOM OF THE POWER **ROCKER** SWITCH IS PRESSED, ITS **RED LIGHT GOES OUT, AND THE DRAIN VALVE AUTOMATICALLY OPENS, DRAINING THE BOILER. AN AUTOMATICALLY-TIMED DRAIN WATER CONDENSER WILL FLUSH THE DRAIN FOR 3 MINUTES, THEN SHUT OFF. AFTER 3 MINUTES THE STEAMER IS READY TO BE RESTARTED.**

When steam is produced, the water in the boiler is being heated. The water, remain in the boiler as the water boils away as steam. When allowed to accumulate, the

water becomes highly mineralized, which results in erratic operation, lime build-up corrosion, and premature electric heater failures. In some cases, complete boiler replacement becomes necessary, which is extremely expensive. By draining the boiler under pressure, most sediment present will be flushed down the drain.

2. The steamer is equipped with a drain in the back of the cooking compartment. No compartment should be operated without the drain screen in place. This screen prevents large food particles from entering and possibly plugging the drain line. Any restriction of the drain line may cause a slight build-up of back-up pressure in the compartment, resulting in steam leaks around the door gasket. It also may adversely affect the convection action of the steam in the compartment, which is critical to optimum performance. Pouring USDA approved drain cleaner through the compartment drains once a week will help to ensure an open drain. A manual (hand crank) drain auger, or "snake", may be safely used to clear obstructions in the compartment drains. Do not use a power auger, as damage to the plastic drain system will result.

With the steamer off open the cooking compartment doors and allow the steamer to cool before cleaning the cooking compartments and their compartments.

3. At the end of each day's operation, wash the pan slide's, steam tubes, door gaskets, and compartment interiors with mild detergent and warm water, either by hand or in a dishwasher. Rinse thoroughly with clear water. Rinse water should drain freely through the compartment drain

opening. If it does not, the drain must be cleaned before using the steamer.

4. Once a week, remove the steam robes and clean the orifices. First, remove the pan slides by lifting upward and toward the center of the compartment. Pressing backward on the steam tube will allow its front eyelet to clear the compartment stud. The tube is then angled toward the center of the compartment just enough to clear the stud and be pulled forward, out of its socket. The orifices can be cleaned easily with a paper cap. Then, thoroughly wash and rinse all steam tubes. This can be done in a dishwasher. Lubricate each tube's tapered end with cooking oil before replacing in the steamers compartments. Be sure all four steam tubes are securely in place before activating the compartment. The tubes are interchangeable and may be placed in any spot in either compartment.
5. To prolong door gasket always leave compartment door ajar when not in use.
6. Exterior Care: Allow steamer to cool before washing. Use the same cleaners and cleaning procedures as for other kitchen surfaces of stainless steel and aluminum. Mild soapy water, with a clear water rinse, is recommended. Do not allow water to run into electrical controls. Always turn off equipment power before using water to wash equipment. Do not hose down the steamer.

### WARNING

Do not store or use gasoline or other flammable vapors and liquids in the vicinity of this or any other appliance.

### MAINTENANCE

**Periodically, a qualified serviceman should be summoned for routine preventive maintenance.**

1. The blowdown procedure will not completely remove the mineral deposits that adhere to the top of the boiler. A chemical descaling should be done by a boiler treatment specialist. This should be done once a year in average water conditions, but in poor water areas it may be needed two or three times a year.
2. Periodic boiler inspection should be made by a qualified serviceman.
- 3- Once every three months, the cold water line strainer should be cleaned.

Cleveland Ranges supports a comprehensive network of Maintenance and Repair Centers (regional parts and service distributors) throughout the United States and Canada. Please contact your nearest distributor for the name of an authorized service agency in your area, or for replacement pans and information regarding the proper maintenance and repair of Cleveland Range equipment. In order to maintain the various agency safety certifications, only factory-supplied replacement parts should be used. The use of other than factory-supplied replacement parts will void the warranty.



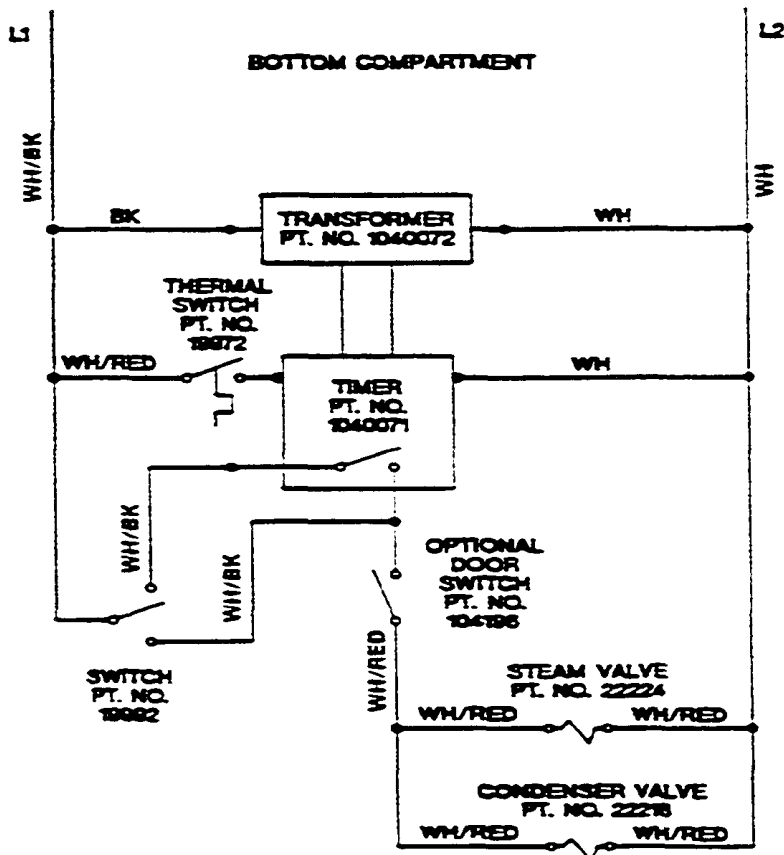
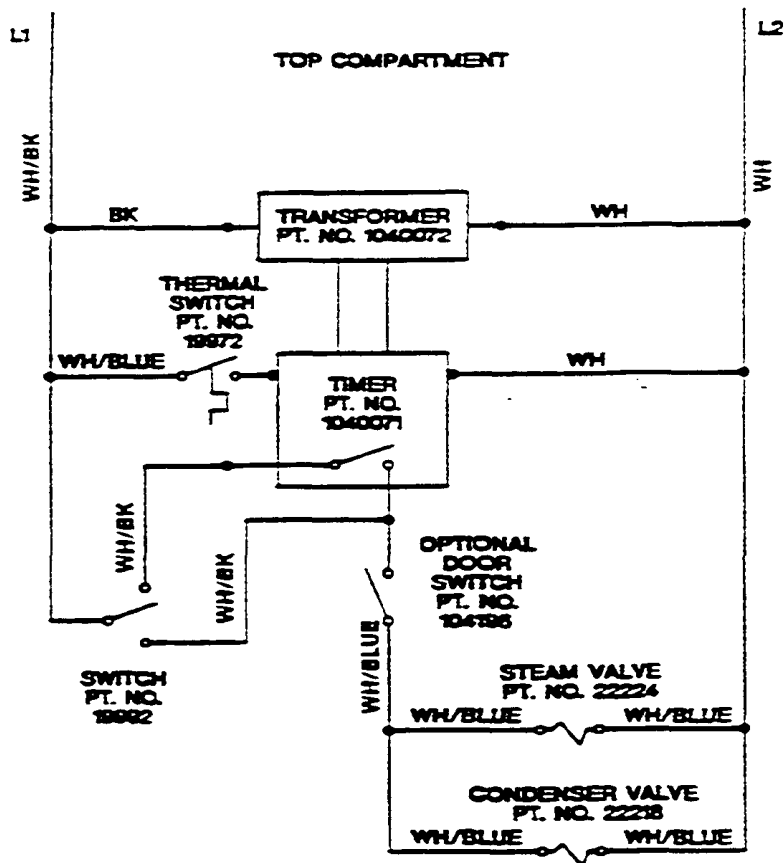

COMPARTMENT CONTROL - ELECTRONIC TIMER 10424

## CONVECTION STEAMER TIMER SETTINGS

Timer settings are approximate due to the differences in food quality, age, shape and the degree of doneness desired. 1: is no necessary to add water- Perforated pans are recommended. Starred items (\*) must be cooked in solid pans or- containers. Items marked with two stars (\*\*) require handling in two steps. First, steam for approximately 1/2 the time shown, remove from steamer separate thawed portion, or stir and return to the steamer for the time remaining. The compensating feature of the timer allows the cooking compartment to reach cooking temperature before the preset time starts to count up.

(In Minutes)

VEGETABLES:	Fresh	Frozen
Artichoke	12	
Asparagus, spears	4	6
Beans, green 2" cut	6	5
French cut	4	5"
whole	6	4
Broccoli, spears	3	2-3
flowerettes	2-3	2-3
chopped		6-8
Brussels sprouts	4-5	4
Cabbage		
12-16 wedges/head	4	
Cabbage,		
whole - to remove leaves	2	
for cabbage rolls		
Carrots, baby whole	10	6
sliced, crinkle cut	7-8	3
diced		2
Cauliflower, flowerettes	4-5	3-4
whole	10	
Celery, diagonal cut 1 1/2"	3	
diced	2	1
minced	1	
Corn, yellow whole kernel		2
on cob, cobbettes	6	12"
Eqptant, sliced, diced	1	
Mixed vegetables •		3-4
Mushrooms, whole (1 1/2"	3	
sliced	1	
Onions, diced, sliced	2-3	1
whole	4	2
Peas, green		2
Potatoes, white 8 oz	30-35	
peeled, quartered, fresh	12-19	
peeled, diced	8-10	
Potatoes, sweet whole	30-35	
Spinach leaf	2	
chopped		21-
Squash, acorn halves	15	
butternut, quartered	7	
whipped*		20-
spaghetti squash, halves	15-18	
Tomatoes, whole, sliced	1	
Turnips, whole	20-25	
Zucchini, sliced	2-4	2-4

SEAFOODS: Steam all seafoods on a perforated pan- with catch pan.

(In Minutes)

	Fresh	Frozen
Clams in shell	3-5	
Cod fillets, 5 oz- portions	3	4
Crab legs, king		4-6
Snow crab		2-4
Crab, live, 4 oz	4	
3/4 - 1 lb.	12	
Halibut, 6-8 oz portions	4-6	6-8
Lobster, whole, 1 lb.	7-9	
Lobster tails, 8 oz		8-10
defrosted, butterflied		4-6
Mussels in shell	2	
Oysters in shell	2-4	
Red snapper, 8 oz-	4-5	4-5
Salmon steak, 8 oz.	6	7
Shrimp, 10 ct. per lb. IQF	3	4-6
5 lb. block, peeled &"		
deveined 30 ct.		6-8-
5 lb. block, green, 26-30 ct	(nested pan)	10-
EGGS (Medium Sized):		
Hard cooked for egg salad.		
potatoe salad	10-12	
Soft cooked	•a	
Coddled	6	
Poached in a cup	2-3	
Scrambled*	6-7-	
FRUITS:		
Blanch for peeling		
Fresh: Avocado	1	
Apple, cored	1	
Grapefruit	1	
Orange	1	
Apricot	1	
Pineapple, whole	2	
Dried': add water to re-hydrate		
Apple	10	
Apricot	10	
Peach	10	
Pear	10	
Prune	10	

# CONVECTION STEAMER TIMER SETTINGS

(continued)

## MEATS & POULTRY:

Steam meats and poultry in nested pans. as juices can be used for gravy, sauces. beef stock and soups. The size of portion, thickness of cut, grade, should be considered when selecting a timer setting for doneness.

POULTRY	Fresh	Frozen
Turkey, whole	6-8 min/lb.	6-8 min/lb.
Chicken, 5-8 oz breaded pieces	18-20 min.	
halves. 1 1/4 -1 1/2 .lb. per half	20-24 min.	20-24min.

## PORK, SAUSAGE, HOT DOGS:

Pork- Chop. 4 count/lb.	10min.
Italian sausage. 4 oz. portion	10 min.
Ribs. 3 lb and down	20-26 min
Hot dogs 8 count/lb.	2min

## BEEF:

Cubes, 1 1/2"	6-7 min./lb.	6 min/lb.
Ground chuck for chili	4-6 min/lb.	4-6 min/lb.
Pot roast, choice	8-12 min/lb.	
Rump roast. choice boned- rolled, tied	12 min/lb.	
Meat loaf. 4 lb. loaf	5 min/lb.	
Liver baby bee?. 8 oz- slice	2-4 min.	2-4 min.
Corned beef. 6-8 lb. CUT add 1/2" water to pan	20-23 min/lb.	

## STEAKS:

Using a 3/4" to 1" steak, the steaming time tested below produces a "rare" steak. A "well done" steak is first steamed to the "rare" stage then broiled or grilled for 1 1/2 minutes on each side. This "well done" steak shrinks less is more tender and juicy and when served, is the same size as the "rare" steak.

Sirloin patties	4 min.
chopped. 8 oz	4 min.
Rioeye. 8 oz.	4 min.
Top butt steak. 6 oz.	6 min.
8 oz.	3 min.
Filet Mignon, Butterflied — 4 oz.	3-4min.
6 oz.	4.min.
8 oz	5 min.
10 oz	8 min
16 oz. whole (Chateaubrand)	

## STEAKS:

Strip steak — 10 oz-	5	min.
12 oz	7	min.
T-bone — 12 oz	5	min.
16oz	8	min
18 oz-	8	min.
22 oz'	10	Min.

## PREPARED ENTREES:

	Fresh	Frozen
Full size pans		
Cabbage rolls stuffed cover' with tomato sauce & serve	25 min	20 min.
Casserole dishes"		
beef stew,	20-25 min.	25-30 min.
stroganoff	20-25 min.	25-30 min.
Lasagna". freshly prepared	20-25 min	25-30 mm.
reheat each serving 4"	6-8 min.	12 min.

## DEHYDRATED FOODS:

Potatoes': 2 1-2 # random sliced plus 5 cups cold water/lb.	12 min.
	17 min

## RICE & BEANS:

Rice*. long again
4 cups cold water/lb.
Beans*, pre-soaked over-night
1 lb. beans + 1 1/4 qts. water
Beans*, unseated.
1 to. beans +1 1/2 qts water
Refried beans'. 2 #10 cans

## PASTA:

Steam in nested pans. Place pasta on 2 1/2" perforated pan used as a finer in a solid 2 1/2 pan. Cover pasta with cold water.	
Egg noodles, 1 1/2" wide	4-6 min" 10-12min" 10-12 min" 10
Lasagna noodles	Min" 8 min" 10 min."
Macaroni, shells. elbow	
Rigatoni	
Spaghetti, vermicelli	
Spaghetti, regular	

NOTE:

- 1.) ITEMS 49 & 50 NOT USED ON GAS GENERATOR BASE OR ON ANY OTHER BACKPLASH-EQUIPPED UNIT.
- 2.) ITEMS MARKED REF. ARE NOT INCLUDED IN BTY. REQUIREMENTS.

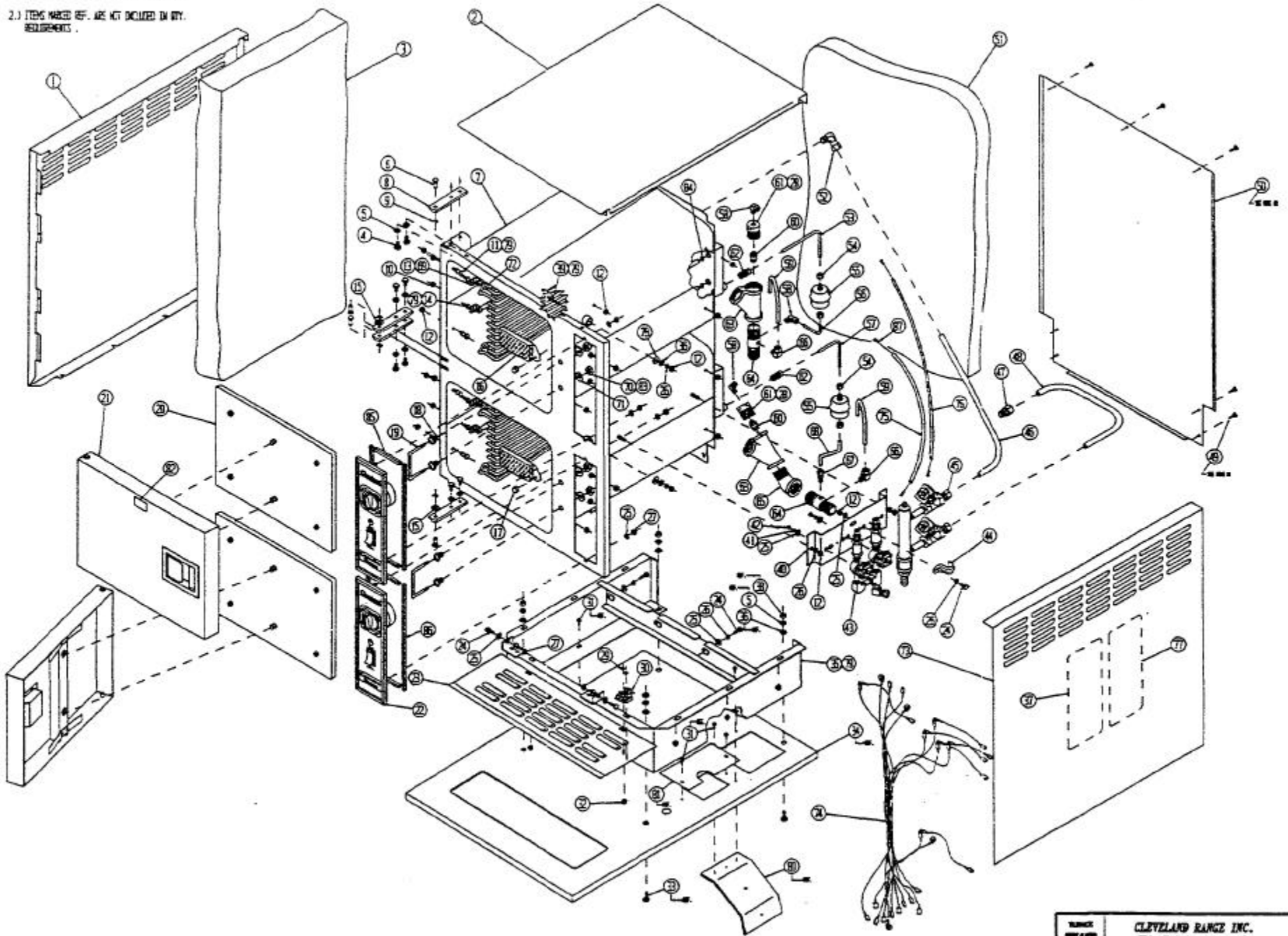

ALL DIMENSIONS & PROPORTIONS ARE TO BE MAINTAINED UNLESS OTHERWISE SPECIFIED. THE DIMENSIONS OF THE ITEMS TO BE ORDERED SHALL BE IN ACCORDANCE WITH THE DRAWING.

CLEVELAND RANGE INC.				
138 East 19th St. Cleveland, Ohio 44102-2201				
REV.	DATE	BY	APP'D.	DESCRIPTION
1	M/A		P.J.S.	ISSUE 1
2	M/A			FINAL ASSEMBLY CONNECTION REWORKED, HOLE LEFT
3	M/A			
4				
5				
6				
7				
8				
9				
10				
11				
12				
13				
14				
15				
16				
17				
18				
19				
20				
21				
22				
23				
24				
25				
26				
27				
28				
29				
30				
31				
32				
33				
34				
35				
36				
37				
38				
39				
40				
41				
42				
43				
44				
45				
46				
47				
48				
49				
50				

LEI.			REVISIONS	DATE	DI
-			PRODUCTION RELEASE E.O. #C-1997	09-30-91	PO
87	4	101774	INSERT, PARTS FOR 1/4" 0.0. POLY TUBE		
86	4	104612	FOAM, TAPE 1/4 X 1/4 X 13		
85	4	104613	FOAM, TAPE 1/4 X 1/4 X 3-1/2		
84	8	15203	"O" RING, 3/8 1.0 X 1/2 0.0.		
83	A/R	01205	ADHESIVE, LOCKTITE #290		
82	1	14919	LABEL, CAUTION HOT DOORS AND HANDLES		
81	-	104210	SHIELD, HEAT-TABLETOP		
80	-	104591	SHIELD ASSY.. 900MM.1050MM LG. GAS		
	-	104590	SHIELD ASSY.. 600MM, 900MM 1050MM SM GAS		
79	A/R	00932	SEALANT, RTV		
78	2	23120	WASHER, FLAT 3/8 X 7/8		
77	1	104123	LABEL, LADDER DIAGRAM		
76	1	1022333000	TUBE, UPPER COMPT. CONDENSER X 30"		
75	1	1022332400	TUBE, LOWER COMPT. CONDENSER X 24"		
74	1	103856	HARNESS WIRING MECHANICAL		
73	1	66014	PANEL, RIGHT SIDE CONV. STMR.		
72	4	41423	RACK, PAN SLIDE, 20"		
71	4	23149	WASHER-NYLON, TYPE 6/6		
70	4	14649	NUT, HEX, 1/2-12, ZINC PLTD		
69	A/R	00908	LUBRICANT, "O" RING		
68	1	102154	TUBE, COPPER TRAP TO DRAIN-LOWER		
67	1	06190	FITTING, COMPRESSION 1/4 T X 1/8 MPT STRAIGHT		
66	2	06233	FITTING, COMPRESSION 3/8 T X 1/8 MPT 90°		
65	1	05227	ELBOW, 1" STREET BLACK 45°		
64	2	56519	FITTING, COMPARTMENT DRAIN, 2 HOLE		
63	2	02139	BEND, "Y", BLACK		
62	2	06216	FITTING, COMPRESSION 1/4 T X 1/4 MPT STRAIGHT		
61	2	06230	FITTING, COMPARTMENT DRAIN		
60	2	14555	NOZZLE, SPRAY, BRASS 1/8" FULL JET		
59	2	70732	TUBE, COPPER-DRAIN VENT		
58	3	06192	FITTING, TUBE 1/4 T X 1/8 MPT 90°		
57	1	70776	TUBE, COPPER, STEAMBOX TO TRAP-LOWER		
56	1	70758	TUBE, COPPER, TRAP TO DRAIN-UPPER		
55	2	20559	TRAP, 1/4 X 1/4 THERMOSTATIC		
54	4	14661	NUT, COMPRESSION, FITTING, BRASS, 1/4" TUBE		
53	1	70726	TUBE, COPPER, STEAM BOX TO TRAP-UPPER		
52	1	06203	FITTING, COMPRESSION 1/2 T X 3/8 MPT 90°		
51	1	104126	INSULATION, CONVECTION BODY REAR		
50	1	69239	PANEL, REAR OUTER, SHEETING CONV. STMR.		
49	7	19267	SCREW, TRUSS HEAD, SHT. METEL		
48	1	70734	TUBE, STEAM SUPPLY-LOWER COMPARTMENT		
47	1	06202	FITTING COMPRESSION 1/2 T XC 3/8 MPT ST		
46	1	70735	TUBE, STEAM SUPPLY-UPPER COMPARTMENT		
45	1	423951	STEAM, INLET ASSEMBLY		
44	1	03197	CLAMP, 1 HOLE 3/4"		
43	1	44064	WATER VALVE ASSEMBLY NEW CONV. STMR.		
42	2	19147	SCREW, PAN HD STLD 8-32 S/S		
41	2	100711	WASHER, INTERNAL TOOTH LOCK S/S #B		
40	1	52598	BRACKET, VALVE, SUPPORT CONV. STMR.		
39	2	104409	CLOSURE, THERMAL OPENING		
38	-	14652	NUT, HEX 5/16-18 S/S		
37	1	104398	LABEL, WIRING SCHEMATIC		
36	2	23134	WASHER, FLAT 5/16"		
35	1	40749	PEOSTAL, WELMENT HINGE-LEFT		
34	-	70085	TABLETOP HINGE LEFT 900MM		
	-	70082	TABLETOP HINGE LEFT 1050MM		
	-	70084	TABLETOP, HINGE LEFT & RIGHT 600MM		
33	-	19196	SCREW, HEX HD, 5/16 X 18 X 3/4		
32	8	14679	NUT, ACORN 10-24 S/S		
31	-	19148	SCREW, HEX WASH HD.. SHEET METAL		
30	1	44168	TERMINAL BLOCK ASSEMBLY 2 POLE		
29	2	104223	NUT, HEX 6-32 ELASTIC LOCK		
28	A/R	101051	NEVER-SEEZ		
27	6	14665	NUT, HEX 1/4-20 ELASTIC LOCK W/ NYLON INSERT		
26	7	23105	WASHER, LOCK S/S 1/4"		
25	13	23116	WASHER, FLAT S/S 1/4"		
24	5	19288	SCREW, HEX HEAD 1/4-20		
23	1	1025691	PANEL, FRONT FILLER		
22	2	104501	TIMER ASSY, CONVECTION STEAMER MECHANICAL		
21	2	103537	DOOR, OUTER ASSEMBLY HINGE LEFT		
20	2	104101	DOOR, INNER ASSEMBLY		
19	2	104046	CATCH, DOOR		
18	4	14695	NUT, DOOR CATCH MOUNTING S/S		
17	2	146771	NUT, ACRON 1/4-20		
16	2	69298	SCREEN, COMPARTMENT DARIN		
15	2	102513	WASHER, FLAT S/S 5/15 X 3/4 X .080		
14	8	101471	PIN STEAMTURE SUPPORT		

13	8	41212	TUBE, ASSEMBLY, CONVECTION STEAMER
12	21	14618	NUT, HEX 1/4-20 S/S
11	16	101305	PIN, RACK
10	8	14659	NUT, HEX 10-24 S/S
9	4	104062	RING, SNAP S/S
8	4	104078	HINGE, DOOR
7	1	103557	CONVECTION STEAMER BODY HINGE-LEFT ASSEMBLY
6	4	104077	PIN, HINGE
5	8	23106	WASHER, LOCK MEDIUM PATTERN 5/16 S/S
4	8	02312	BOLT, HEX 5/16-24 S/S
3	1	104125	INSULATION, CONVECTION BODY WRAP
2	1	66015	PANEL, TOP SHEETING ASSY.
1	1	66023	PANEL, LEFT-SIDE OUTER CONV. STMR.
<b>ITEM</b>	<b>QTY</b>	<b>PART #</b>	<b>DESCRIPTION</b>
TOLERANCES (EXCEPT AS NOTED)		CLEVELAND RANGE INC. 1333 East 179 <sup>th</sup> St. Cleveland, Ohio 44110-2574	
DECIMAL 1 N/A		SCALE N/A	DRAWN BY: P.J.D.
ANGULAR 1 N/A		TITLE FINAL ASSEMBLY CONVECTION MECHANICAL HINGE LEFT	
CK		DATE 07-15-91	DRAWING NO. D-104516
			REV. -

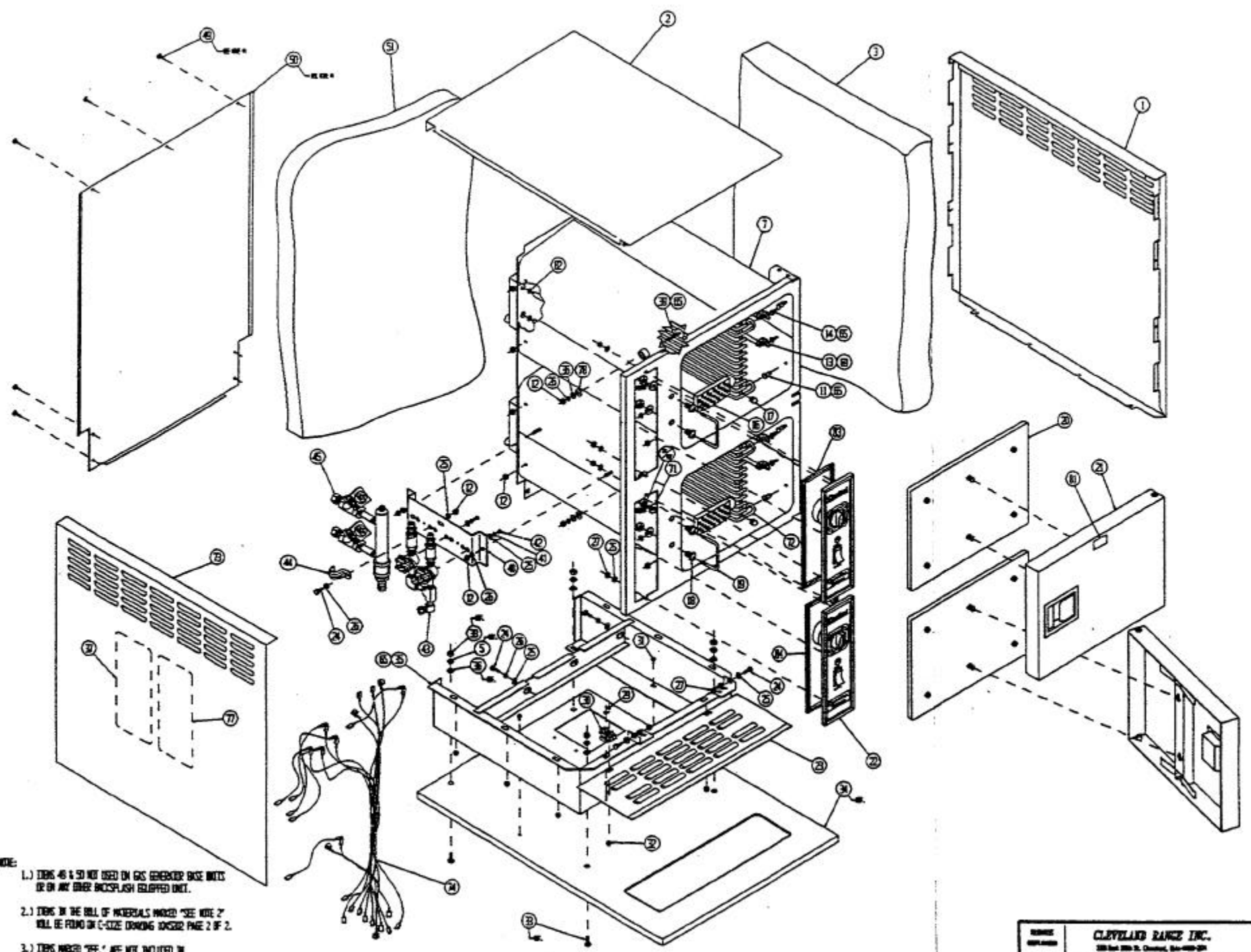

- NOTE:
- 1.) ITEMS 46 & 50 NOT USED ON GAS GENERATOR BASE UNITS OR ON ANY OTHER BACKPLASH EQUIPPED UNIT.
  - 2.) ITEMS IN THE BILL OF MATERIALS MARKED "SEE NOTE 2" WILL BE FOUND IN C-SIZE DRAWING LONGER PAGE 2 OF 2.
  - 3.) ITEMS MARKED "REF." ARE NOT INCLUDED IN QUANTITY REQUIREMENTS.

THIS DRAWING IS THE PROPERTY OF CLEVELAND RANGE, INC. IT IS TO BE KEPT IN CONFIDENCE AND NOT TO BE REPRODUCED OR COPIED IN ANY MANNER WITHOUT THE WRITTEN PERMISSION OF CLEVELAND RANGE, INC.

CLEVELAND RANGE INC.		200 East 20th St., Cleveland, Ohio 44115-2020	
SCALE	1" = 2"	DATE	P.L.D.
AREA	FOAM ASSEMBLY CONNECTION MECHANICAL RANGE EQUIP		
DC	11-04-88	D-104520	PAGE 1 OF 2

	LET.	REVISIONS	DATE	BY
SEE NOTE 2	85	4	101774	INSERT, BRASS FOR 1/4" POLY TUBE
	84	4	104612	FOAM, TAPE 1/4 X 1/4 X 12-3/4
	83	4	104613	FOAM, TAPE 1/4 X 1/4 X 3-3/4
	82	8	15203	"O" RING, 3/8 I.D. X 1/2 O.D.
	81	2	14919	LABEL, CAUTION HOT DOORS AND HANDLES
REF.	80		104210	SHIELD, HEAT, TABLETOP CONVECTION
			104591	SHEILD ASSEMBLY, 900MM, 1050MM, LG, GAS
			104590	SHEILD ASSEMBLY, 600MM, 900MM, 1050M, SM, GAS
	78	2	23120	WASHER, FLAT 3/8 X 7/8
	77	1	104123	LABEL, LADDER DIAGRAM
SEE NOTE 2	76	1	10222333000	TUBE, UPPER COMPT. CONDENSER
	75	1	10222332400	TUBE, LOWER COMPT. CONDENSER
	74	1	103885	HARNESS WIRING MECHANICAL
	73	1	66014	PANEL, RIGHT-SIDE CONV. STMR.
	72	4	41423	RACK, PAN SLIDE, 20"
	71	4	23149	WASHER-NYLON, TYPE 6/6
	70	4	14649	NUT, HEX, 1/2-13
	69	A/P	0908	LUBRICANT "O" RING
SEE NOTE 2	68	1	70769	TUBE, COPPER TRAP TO DRAIN - LOWER
	67	A/P	01205	ADHESIVE, LOCKTITE #290
SEE NOTE 2	66	2	06233	FITTING, COMPRESSION 3/8 T X 1/8/ MPT 90°
	65	A/P	00932	SEALANT, RTV
	64	2	56519	FITTING, COMPARTMENT DRAIN
	63	2	02139	BEND, "Y", BLACK
	62	2	06216	FITTING, COMPRESSION 1/4 T X 1/4 MPT STRAIGHT
	61	2	06230	FITTING, COMPARTMENT DRAIN
	60	2	14555	NOZZLE, SPRAY, BRASS 1/8" FULL JET
	59	2	70732	TUBE, COPPER - DRAIN VENT
SEE NOTE 2	58	3	06192	FITTING, TUBE 1/4 T X 1/8 MPT 90°
	57	1	70770	TUBE, COPPER, STEAMBOX TO TRAP - LOWER
	56	1	70758	TUBE, COPPER, TRAP TP DRAIN - UPPER
	55	2	20559	TRAP, 1/4 X 1/4 THERMOSTATIC
	54	4	14681	NUT, COMPRESSION, FITTING, BRASS, 1/4" TUBE
	53	1	70728	TUBE, COPPER, STEAMBOX TO TRAP - UPPER
	52	1	06203	FITTING, COMPRESSION 1/2 T X 3/8 MPT 90°
	51	1	104128	INSULATION, CONVECTION BODY REAR
SEE NOTE 1	50	1	69239	PANEL, REAR OUTER, SHEETING CONV. STMR.
	49	7	19287	SCREW, TRUSS HEAD, SHEET METAL
SEE NOTE 2	48	1	70734	TUBE, STEAM SUPPLY - LOWER COMPARTMENT
	47	1	06202	FITTING, COMPRESSION 1/2 T X 3/8 MPT ST.
	46	1	70735	TUBE, STEAM SUPPLY - LOWER COMPARTMENT
	45	1	423951	STEAM, INLET ASSEMBLY
	44	1	03197	CLAMP, 1 HOLE, 3/4"
	43	1	44064	WATER VALVE ASSEMBLY NEW CONV. STMR.
	42	2	19147	SCREW, PAN HD STLD 8-32 S/S
	41	2	23114	WASHER, INTERNAL TOOTH LOCK S/S #10
	40	1	52598	BRACKET, VALVE, SUPPORT CONV. STMR.
	39	2	104409	CLOSURE, THERMAL OPENING



REF.	38		14652	NUT, HEX 5/16-18 S/S
	37	1	104398	LABEL, WIRING SCHEMATIC
	36	2	23134	WASHER, FLAT 5/16"
	35	1	407491	PEDESTAL, WELDMENT HINGE-RIGHT
			70081	TABLETOP HINGE RIGHT 900MM
REF.	34		70083	TABLETOP HINGE RIGHT 1050MM
			70084	TABLETOP HINGE LEFT AND RIGHT 600MM
REF.	33		19196	SCREW, HEX HD, 5/16 X 18 X 3/4
	32	8	14679	NUT, ACORN 10-24 S/S
	31	2	19148	SCREW, HEX,WASH HD
	30	1	44168	TERMINAL BLOCK ASSEMBLY 2 POLE
	29	2	104223	NUT, HEX 6-32 ELASTIC LOCK
SEE NOTE 2-	28		101051	NEVER-SEEZ
	27	6	101873	NUT, HEX 1/4-20 ELASTIC LOCK
	26	7	23105	WASHER, LOCK S/S 1/4"
	25	11	23118	WASHER, FLAT S/S 1/4"
	24	5	19288	SCREW, HEX HEAD 1/4-20
	23	1	1025691	PANEL, FRONT FILLER
	22	2	104501	TIMER ASSY. CONVECTION STEAMER MECHANICAL
	21	2	1035372	DOOR, OUTER ASSEMBLY HINGE RIGHT
	20	2	104101	DOOR, INNER ASSEMBLY
	19	2	104046	CATCH, DOOR
	18	4	14695	NUT, DOOR CATCH MOUNTING S/S
	17	2	146771	NUT, ACORN 1/4-20
	16	2	69298	SCREEN, COMPARTMENT DRAIN
SEE NOTE 2-	15	2	102513	WASHER, FLAT S/S 5/15 X 3/4 X .080
	14	8	101471	PIN, STEAMTUBE SUPPORT
	13	8	41212	TUBE, ASSEMBLY, CONVECTION STEAMER
	12	21	14618	NUT, HEX 1/4-20 S/S
	11	16	101305	PIN, RACK
SEE NOTE 2-	10	8	14659	NUT, HEX 10-24 S/S
	9	4	104062	RING, SNAP S/S
	8	4	104076	HINGE, DOOR
	7	1	103558	CONVECTION STEAMER BODY HINGE - RIGHT ASSEMBLY
SEE NOTE 2-	6	4	104077	PIN, HINGE
	5	8	23106	WASHER, LOCK MEDIUM PATTERN 5/16 8/9
	4	8	02312	BOLT, HEX HEAD 5/16-24 S/S
	3	1	104125	INSULATION, CONVECTION BODY WRAP
	2	1	66015	PANEL, TOP SHEETING ASSY.
	1	1	66023	PANEL, LEFT - SIDE OUTER CONV. STMTR.
	ITEM	QUANTITY	PART NO.	DESCRIPTION

<b>Cleveland Range inc.</b>			
<b>1300 East 179<sup>th</sup> Street, Cleveland, Ohio 44110-2514</b>			
TOLERANCES EXCEPT AS NOTED	SCALE	DRAWN BY	APPROVED BY
DECIMAL ± N/A	.333"	DUTCHMAN	-
ANGULAR ± N/A	TITLE	FINAL ASSEMBLY CONVECTION MECHANICAL – HINGE RIGHT	
OK	DATE	DRAWING NO.	REV.
	11-04-91	D-104520 PAGE 1 OF 2	-

NOTE:

- 1.) ITEMS 49 & 50 NOT USED ON GAS GENERATOR BASE OR ON ANY OTHER BACKSPASH EQUIPPED UNIT.
- 2.) ITEMS MARKED REF. ARE NOT INCLUDED IN QTY. REQUIREMENTS.

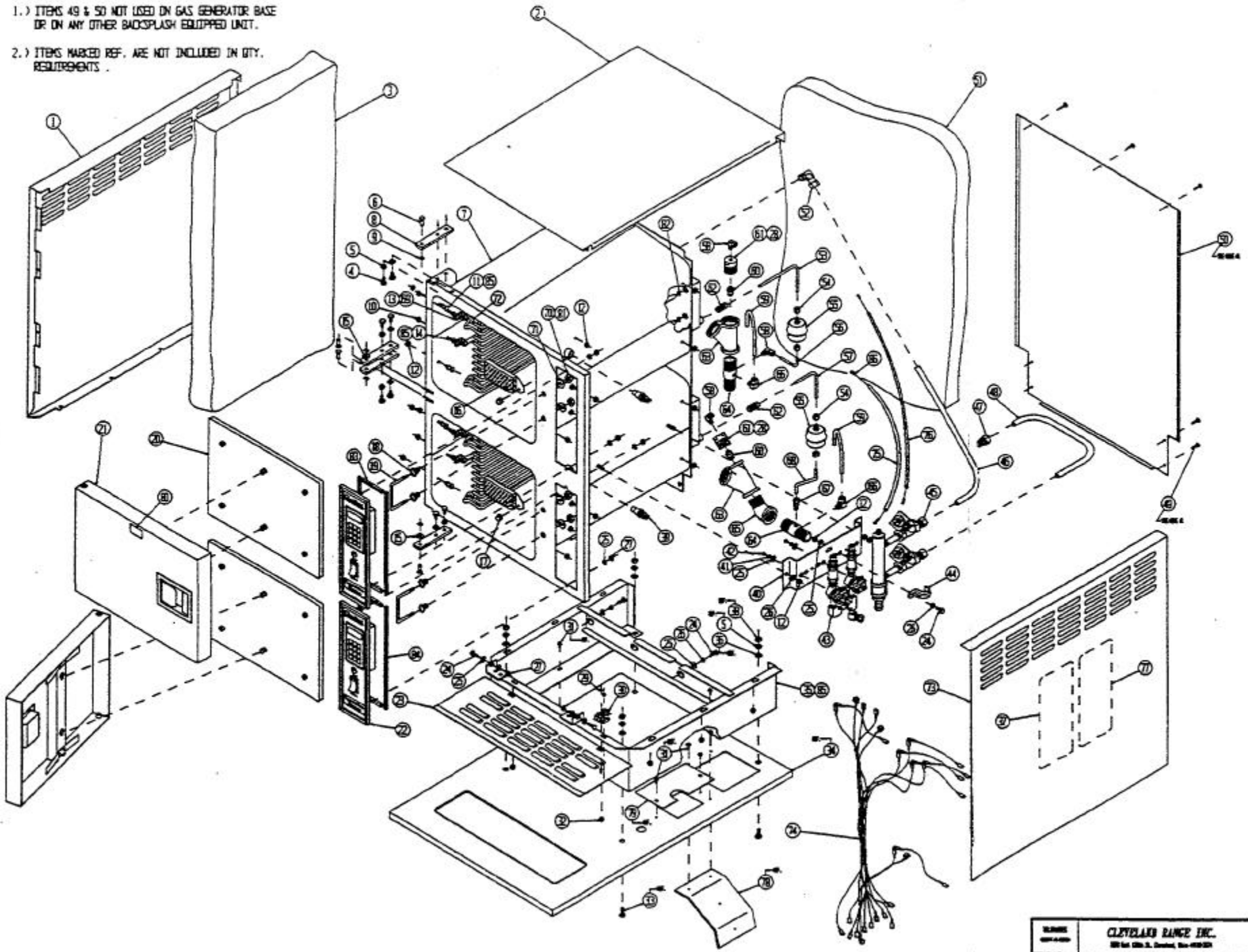

SEE YOUR LOCAL A REPRESENTATIVE FOR  
 ALL IN THE INTEREST OF QUALITY SERVICE.  
 SEE PARTS LIST FOR COMPLETE LISTING  
 OF ALL PARTS & COMPONENTS.

CLEVELAND RANGE INC.				
300 East 12th St., Cleveland, Ohio 44115-1211				
QTY.	QTY.	QTY.	P.L.S.	QTY.
1	1	1	1	1
RANGE ASSEMBLY COMPLETE ELECTRICAL WIRING LEFT				
CC	07-16-78	07-16-78	07-16-78	07-16-78

LET.  
-

Revisions  
PRODUCTION RELEASE E.O WC-1997

Date  
09-30-91

BY  
PD

	86	4	101774	INSERT, BRASS FOR 1/4" 0.0. POLY TUBE
	85	A/R	00932	SEALANT, RTV
	84	4	104612	FOAM, TAPE 1/4 X 1/4 X 13
	83	4	104613	FOAM, TAPE 1/4 X 1/4 X 3 1/2
	82	8	15203	"O" RING, 3/8 I.D. X 1/2 O.D.
	81	A/R	01205	ADHESIVE, LOCKTITE #290
	80	1	14919	LABEL, CAUTION HOT DOORS AND HANDLES
REF {	79	-	104210	SHIELD, HEAT - TABLETOP
REF {	78	-	104591	SHIELD, ASSY., 900MM, 1050MM, LG, GAS
REF	-	-	104590	SHIELD, ASSY., 600MM, 900MM, 1050MM SM. GAS
	77	1	104124	LABEL, LADDER DIAGRAM
	76	1	1022333000	TUBE, UPPER COMPT. CONDENSER X 30'
	75	1	10223332400	TUBE, LOWER COMPT. CONDENSER X 24'
	74	1	104189	HARNES WIRING NCC TIMER
	73	1	66014	PANEL, RIGHT-SIDE CONV, STMR
	72	4	41423	RACK, PAN SLIDE, 20'
	71	4	23149	WASHER-NYLON, TYPE 6/6
	70	4	14649	NUT, HEX 1/2-13, ZINC PLTD
	69	A/R	00908	LUBRICANT, "O" RING
	68	1	102154	TUBE, COPPER TRAP TO DRAIN - LOWER
	67	1	06190	FITTING, COMPRESSION 1/4 T X 1/8 MPT STRAIGHT
	66	2	06233	FITTING, COMPRESSION 3/8 T X 1/8 MPT 90°
	65	1	05227	ELBOW, 1" STREET BLACK 45
	64	2	56519	FITTING, COMPARTMENT DRAIN, 2 HOLE
	63	2	02139	BEND, 'Y', BLACK
	62	2	06216	FITTING, COMPRESSION 1/4 T X 1/8 MPT STRAIGHT
	61	2	06230	FITTING, COMPARTMENT DRAIN
	60	2	14555	NOZZLE, SPRAY, BRASS 1/8" FULL JET
	59	2	70732	TUBE, COPPER - DRAIN VENT
	58	3	06192	FITTING, TUBE 1/4 X 1/8 MPT 90°
	57	1	70776	TUBE, COPPER, STEAMBOX TO TRAP - LINER
	56	1	70758	TUBE, COPPER, TRAP TO DRAIN - UPPER
	55	2	20559	TRAP, 1/4 X 1/4 THERMOSTATIC
	54	4	14661	NUT, COMPRESSION, FITTING, BRASS, 1/4" TUBE
	53	1	70726	TUBE, COPPER, STEAMBOX TO TRAP - UPPER
	52	1	06203	FITTING, COMPRESSION 1/2 T X 3/8 MPT 90°
	51	1	104126	INSULATION, CONVECTION BODY REAR
See Note #1 {	50	1	69239	PANEL, REAR OUTER, SHEETING CONV. STNR.
	49	7	19267	SCREW, TRUSS HEAD, SHT. METAL
	48	1	70734	TUBE, STEAM SUPPLY - LOWER COMPARTMENT
	47	1	06202	FITTING, COMPRESSION 1/2 T X 3/8 MPT ST
	46	1	70735	TUBE, STEAM SUPPLY - UPPER COMPARTMENT
	45	1	423951	STEAM, INLET ASSEMBLY
	44	1	03197	CLAMP, 1 HOLE, 3/4"
	43	1	44064	WATER VALVE ASSEMBLY NEW CONV. STNR.
	42	2	19147	SCREW, PAN HD STLD 8-32 S/S
	41	2	100711	WASHER, INTERNAL TOOTH LOCK S/S #8
	40	1	52598	BRACKET, VALVE, SUPPORT CONV. STNR.
	39	2	19972	SWITCH, THERMAL
REF. -----	38	-	14652	NUT, HEX 5/16-18 S/S
	37	1	104397	LABEL, WIRING SCHEMATIC
REF. -----	36	-	23134	WASHER, FLAT 5/16"
	35	1	40749	PEDESTAL, VELOMENT HINGE-LEFT
	-	-	70085	TABLETOP HINGE LEFT 900MM
REF. -----	34	-	70082	TABLETOP HINGE LEFT 1050MM
	-	-	70084	TABLETOP, HINGE LEFT & RIGHT 600MM
REF. -----	33	-	19196	SCREW, HEX HD. 5/16 X 18 X 3/4
	32	8	14679	NUT, ACORN 10-24 S/S
REF. -----	31	-	19148	SCREW, HEX WASH HEAD, SHEET METAL
	30	1	44168	TERMINAL BLOCK ASSEMBLY 2 POLE
	29	2	104223	NUT, HEX 6-32 ELASTIC LOCK
	28	A/R	101051	HEVER - SEEZ
	27	6	14665	NUT, HEX 1/4-20 ELASTIC LOCK W/ NYLON INSERT

26	5	23105	WASHER, LOCK S/S 1/4"
25	13	23116	WASHER, FLAT S/S 1/4"
24	5	19288	SCREW, HEX HEAD 1/4-20
23	1	1025691	PANEL, FRONT FILLER
22	2	104500	TIMER ASSY. CONVECTION STEAMER ELECTRICAL
21	2	103537	DOOR, OUTER ASSEMBLY HINGE LEFT
20	2	104101	DOOR, INNER ASSEMBLY
19	2	104046	CATCH, DOOR
18	4	14695	NUT, DOOR CATCH MOUNTING S/S
17	2	146771	NUT, ACORN 1/4-20
16	2	69298	SCREEN, COMPARTMENT DRAIN
15	2	102513	WASHER, FLAT S/S 5/15 X 3/4 X .000
14	8	101471	PIN, STEAMTUBE SUPPORT
13	8	41212	TUBE, ASSEMBLY, CONVECTION STEAMER
12	21	14618	NUT, HEX 1/4-20 S/S
11	16	101305	PIN, RACK
10	8	14659	NUT, HEX 10-24 S/S
9	4	104062	RING, SNAP S/S
8	4	104076	HINGE, DOOR
7	1	103557	CONVECTION STEAMER BODY HINGE-LEFT ASSEMBLY
6	4	104077	PIN, HINGE
5	8	23106	WASHER, LOCK MEDIUM PATTERN 5/16 S/S
4	8	02312	BOLT, HEX HEAD 5/16-24 S/S
3	1	104125	INSULATION, CONVECTION BODY WRAP
2	1	66015	PANEL, TOP SHEETING ASSY.
1	1	66023	PANEL, LEFT-SIDE OUTER CONV. STNR.

ITEM	QTY	PART #	DESCRIPTION
------	-----	--------	-------------

TOLERANCES  
(Except as noted)

## CLEVELAND RANGE INC.

1333 East 179<sup>th</sup> St. Cleveland, Ohio 44110-2574

DECIMAL  
N/A  
MODULAR  
N/A

SCALE  
N/A  
TITLE

DRAWN BY  
P.J.O.

APPROVED BY

FINAL ASSEMBLY CONVECTION  
ELECTRICAL HINGE LEFT  
DRAWING NO.

DATE  
07-16-91

REV.  
-

CK

D-104517

- NOTE:
- 1.) ITEMS 49 & 50 NOT USED ON GAS GENERATOR BASE UNITS OR ON ANY OTHER BACKPLASH EQUIPPED UNIT.
  - 2.) ITEMS ON THE BILL OF MATERIALS MARKED "SEE NOTE 2" WILL BE FOUND ON D-SIZE DRAWING 104521 PAGE 2 OF 2.
  - 3.) ITEMS MARKED "REF." ARE NOT INCLUDED IN QUANTITY REQUIREMENTS.

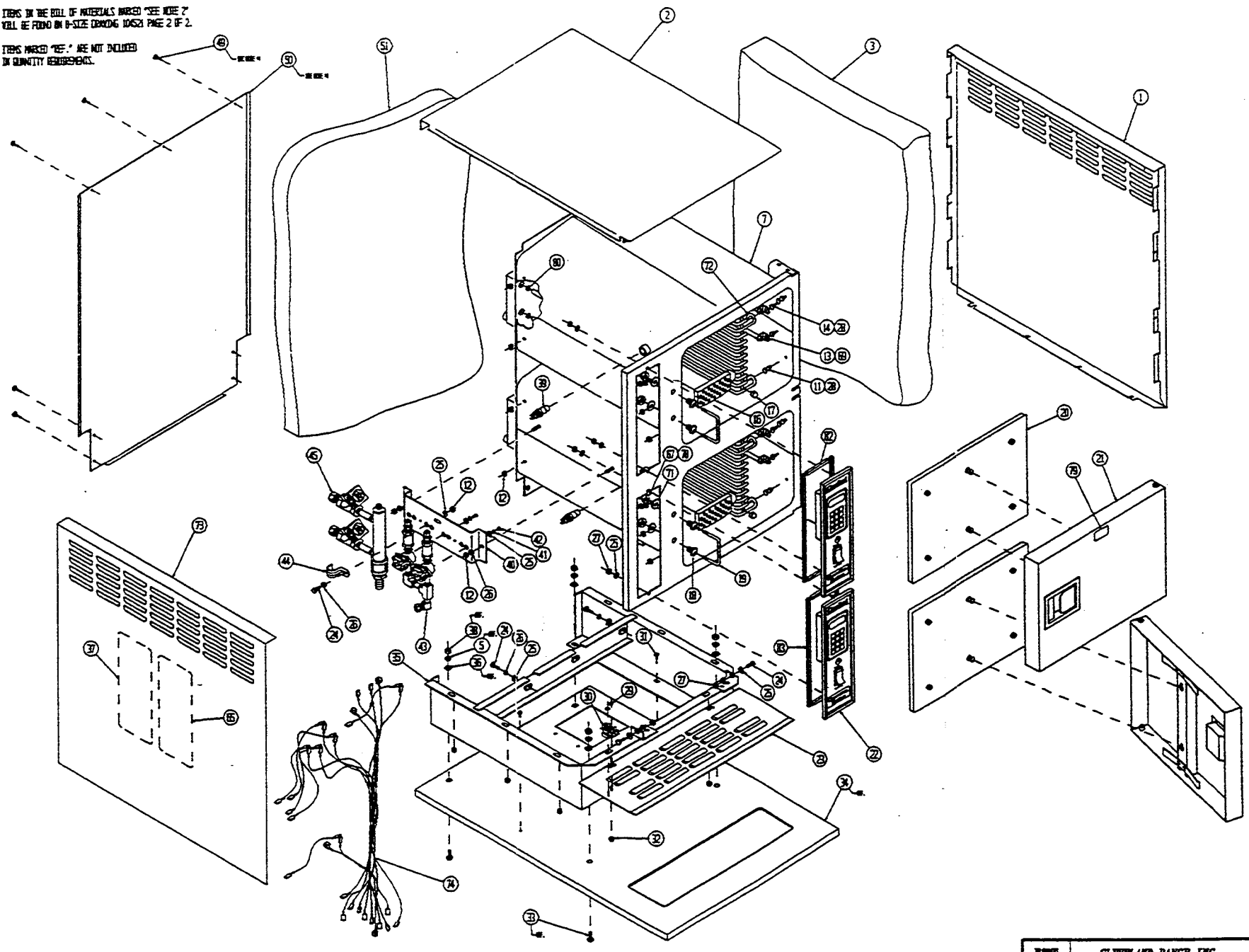

THIS DESIGN REQUIRES A PROPRIETARY TOOL AND IS THE PROPERTY OF CLEVELAND RANGE. THIS DRAWING IS NOT TO BE COPIED OR REPRODUCED WITHOUT THE APPROVAL OF CLEVELAND RANGE.

<b>CLEVELAND RANGE INC.</b>				
138 East 12th St., Cleveland, Ohio 44115-2500				
MODEL:	N/A	SIZE:	N/A	REVISED BY:
DATE:	N/A	DATE:	11-05-91	BY:
FINAL ASSEMBLY CONNECTION ELECTRICAL, PLEASE VERIFY				
D-104521 PAGE 1 OF 2				

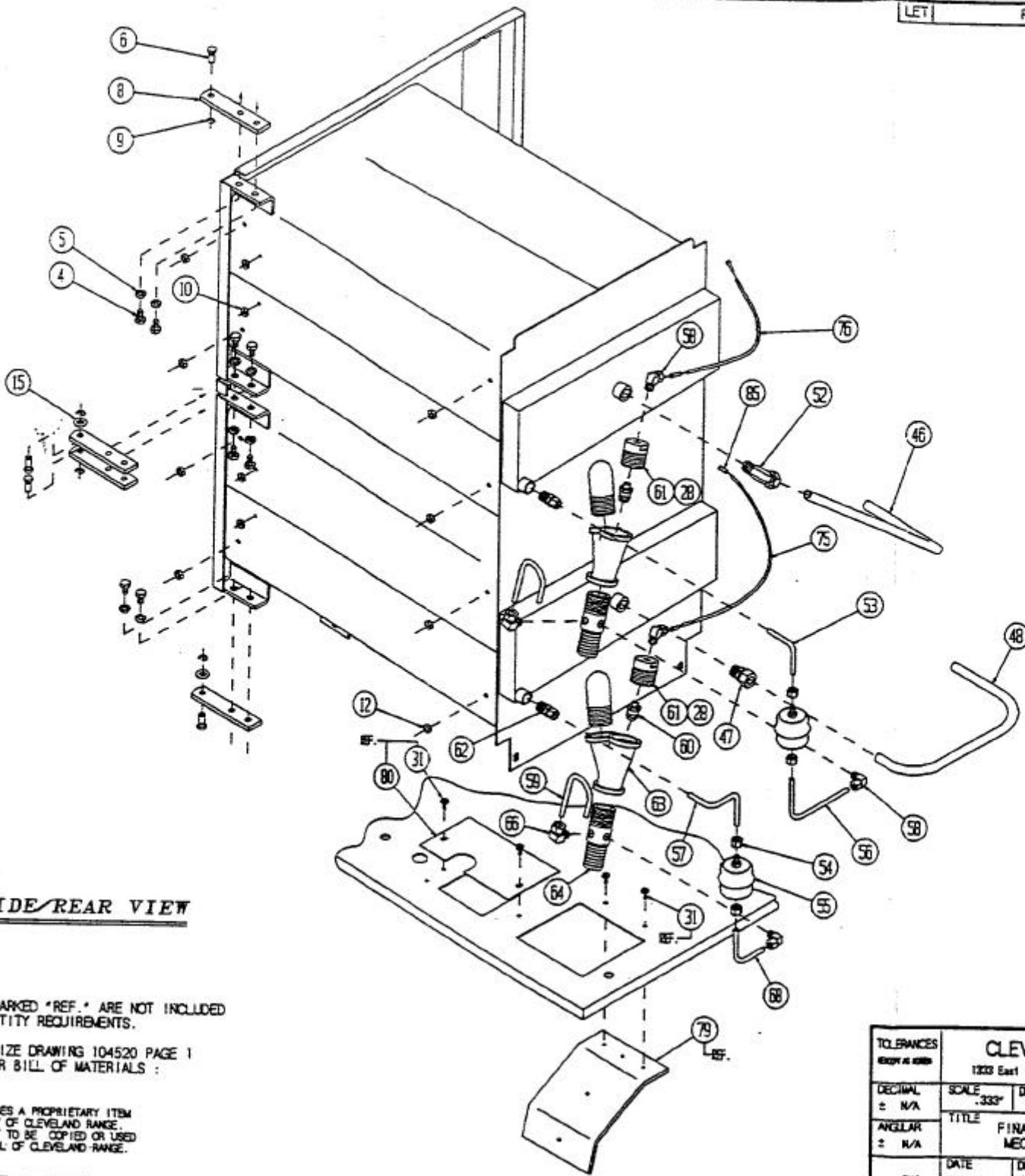

**RIGHT SIDE/REAR VIEW**

NOTE :

- 1) ITEMS MARKED \*REF.\* ARE NOT INCLUDED IN QUANTITY REQUIREMENTS.
- 2) SEE D-SIZE DRAWING 104520 PAGE 1 OF 2 FOR BILL OF MATERIALS :

THIS DESIGN DESCRIBES A PROPRIETARY ITEM AND IS THE PROPERTY OF CLEVELAND RANGE. THIS DRAWING IS NOT TO BE COPIED OR USED WITHOUT THE APPROVAL OF CLEVELAND RANGE.

TOLERANCES EXCEPT AS SHOWN			
<b>CLEVELAND RANGE INC.</b> 1333 East 179th St. Cleveland, Ohio 44110-2574			
DECIMAL ± N/A	SCALE .333"	DRAWN BY DUTCHMAN	APPROVED BY -
ANGULAR ± N/A	TITLE FINAL ASSEMBLY CONVECTION MECHANICAL - HINGE RIGHT		
DATE	DRAWING NO.	REV.	

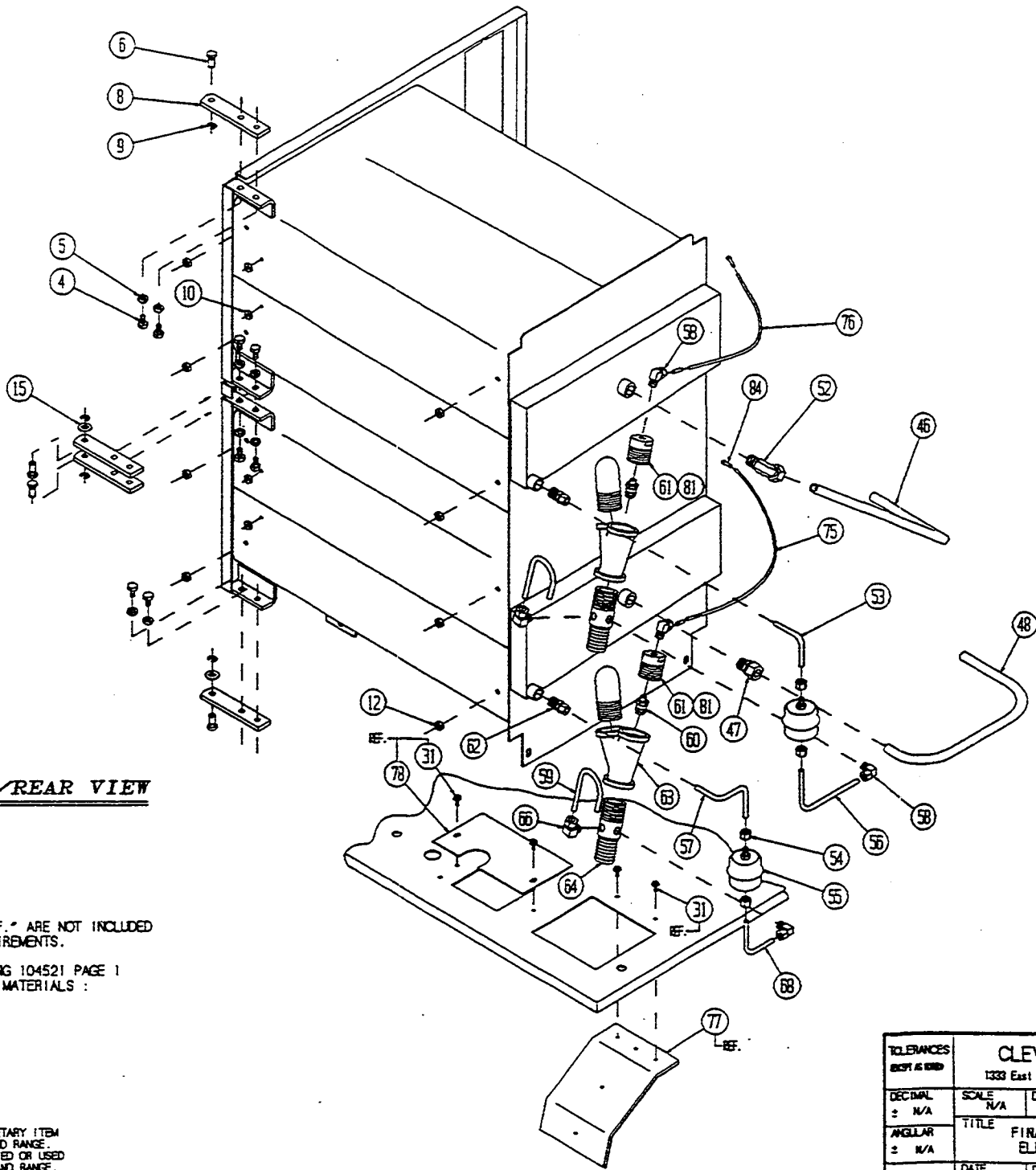

RIGHT SIDE/REAR VIEW

NOTE :

- 1) ITEMS MARKED "REF." ARE NOT INCLUDED IN QUANTITY REQUIREMENTS.
- 2) SEE D-SIZE DRAWING 104521 PAGE 1 OF 2 FOR BILL OF MATERIALS :

THIS DESIGN DESCRIBES A PROPRIETARY ITEM AND IS THE PROPERTY OF CLEVELAND RANGE. THIS DRAWING IS NOT TO BE COPIED OR USED WITHOUT THE APPROVAL OF CLEVELAND RANGE.

TOLERANCES DECIMAL ± N/A ANGULAR ± N/A	<b>CLEVELAND RANGE INC.</b> 1333 East 179th St., Cleveland, Ohio 44110-2574	SCALE N/A	DRAWN BY CUCMWH	APPROVED BY -
TITLE FINAL ASSEMBLY CONVECTION ELECTRICAL - HINGE RIGHT				
DATE 11-05-61	DRAWING NO. D-104521 PAGE 2 OF 2	REV. -		

84	4	101774	INSERT, BRASS 1/4" POLY TUBE
83	4	104812	FOAM, TAPE 1/4 X 1/4 X 12-3/4
82	4	104813	FOAM, TAPE 1/4 X 1/4 X 3-3/4
81	A/R	101051	NEVER-SEEZ
80	8	15203	"O" RING, 3/8 I.D X 1/2 O.D.
79	2	14919	LABEL, CAUTION HOT DOORS AND HANDLES
78	-	104210	SHEILD, HEAT, TABLETOP CONVECTION
77	-	104591	SHEILD ASSEMBLY, 900MM, 1050MM, LG GAS
	-	104590	SHEILD ASSEMBLY, 600MM, 900MM,1050MM SM GAS
76	1	1022333000	TUBE, UPPER COMPT. CONDENSER
75	1	1022332400	TUBE, LOWER COMPT. CONDENSER
74	1	104189	HARNESS WIRING NOC TIMER
73	1	66014	PANEL, RIGHT-SIDE CONV. STMR.
72	4	41423	RACK, PAN SLIDE, 20"
71	4	23149	WASHER-NYLON, TYPE 6/8
70	4	14549	NUT, HEX, 1/2-13
69	A/R	00908	LUBRICANT "O" RING
68	1	102154	TUBE, COPPER TRAP TO DRAIN-LOWER
67	A/R	01205	ADHESIVE, LOCKTITE #290
66	2	06233	FITTING, COMPRESSION 3/8 T X 1/8 MPT 90°
65	1	104224	LABEL, LADDER DIAGRAM
64	2	58519	FITTING, COMPARTMENT DRAIN
63	2	02139	BENS, "Y" BLACK
62	2	06216	FITTING, COMPRESSION 1/4 T X 1/4 MPT STRAIGHT
61	2	06230	FITTING, COMPARTMENT DRAIN
60	2	14555	NOZZLE, SPRAY, BRASS 1/8" FULL JET
59	2	70732	TUBE, COPPER-DRAIN VENT
58	3	06192	FITTING, TUBE 1/4 T X 1/8 MPT 90°
57	1	70770	TUBE, COPPER, STEAMER TO TRAP-LOWER
56	1	70758	TUBE, COPPER, TRAP TO DRAIN-UPPER
55	2	20559	TRAP, 1/4 X 1/4 THERMOSTATIC
54	4	14881	NUT, COMPRESSION, FITTING, BRASS, 1/4" TUBE
53	1	70728	TUBE, COPPER, STEAM BOX TO TRAP-UPPER
52	1	06203	FITTING, COMPRESSION 1/2 T X 3/8 MPT 90°
51	1	104128	INSULATION, CONVECTION BODY REAR
50	1	69239	PANEL, REAR OUTER, SHEETING CONV. STMR.
49	1	19287	SCREW, TRUSS HEAD, SHEET METN.
48	1	70734	TUBE, STEAM SUPPLY-LOWER COMPARTMENT
47	1	06202	FITTING, COMPRESSION 1/2 T X 3/8 MPT ST
46	1	70735	TUBE, STEAM SUPPLY-UPPER COMPARTMENT
45	1	423951	STEAM, INLET ASSEMBLY
44	1	03197	CLAMP, 1 HOLE, 2/4"
43	1	44064	WATER VALVE ASSEMBLY NEWCONV. STMR.
42	1	18147	SCREW, PAN HD STLD 8-32 S/S
41	2	23114	WASHER, INTERNAL TOOTH LOCK S/S #10
40	1	52598	BRACKET, VALVE, SUPPORT CONV. STMR
39	2	104409	CLOSURE, THERMAL OPENING
38	-	14852	NUT, HEX 5/18-18 S/S
37	1	104398	LABEL, WIRING SCHEMATIC
36	2	23134	WASHER, FLAT 5/16"
35	1	407491	PEDESTAL, WELDMENT HINGE-RIGHT
34	-	70081	TABLETOP HINGE RIGHT 900MM
	-	70083	TABLETOP HINGE RIGHT 1050MM
	-	70084	TABLETOP HINGE LEFT & RIGHT 600MM
33	-	19198	SCREW, HEX HD. 5/18 X 18 X 3/4
32	8	14879	NUT. ACORN 10-24 S/S
31	-	18148	SCREW, HEX WASH HD.
30	1	44168	TERMINAL BLOCK ASSEMBLY 2 POLE
29	2	104223	NUT, HEX 6-32 ELASTIC LOCK
28	A/R	101051	NEVER-SEEZ
27	6	101873	NUT, HEX 1/4-20 ELASTIC LOCK
26	5	23105	WASHER, LOCK S/S 1/4"
25	11	23118	WASHER, FLAT S/S 1/4"
24	5	19288	SCREW, HEX HEAD 1/4-20
23	1	1025891	PANEL, FRONT FILTER
22	2	104501	TIMER ASSY, CONVECTION STEAMER MECH.
21	2	1035372	DOOR, OUTER ASSEMBLY HINGE RIGHT
20	2	104101	DOOR, INNER ASSEMBLY
19	2	104048	CATCH DOOR
18	4	4695	NUT, DOOR CATCH MOUNTING S/S
17	2	46771	NUT, ACORN 1/4-20
16	2	69298	SCREEN, COMPARTMENT DRAIN
15	2	102513	WASHER, FLAT S/S 5/15 X 3/4 X .080
14	8	101471	PIN, STEAMTUBE SUPPORT
13	8	41212	TUBE, ASSEMBLY, CONVECTION STEAMER
12	21	14816	NUT, HEX 1/4-20 S/S
11	16	101305	PIN, RACK



10	8	14659	NUT, HEX 10-24 S/S
9	4	104062	RING, SNAP S/S
8	4	104078	HINGE, DOOR
7	1	103558	CONVECTION STEAMER BODY HINGE-RIGHT ASS.
6	4	104077	PIR. HINGE
5	8	23106	WASHER, LOCK MEDIUM PATTERN 5/16 S/S
4	8	02312	BOLT, HEX HEAD 5/18-24 S/S
3	1	104125	INSULATION, CONVECTION BODY WRAP
2	1	66015	PANEL, TOP SHEETING ASSY.
1	1	66023	PANEL, LEFT-SIDE OUTER CONV. STMR.
<b>ITEM</b>	<b>QTY</b>	<b>PART NO.</b>	<b>DESCRIPTION</b>
TOLERANCES (EXCEPT AS NOTED)		<b>CLEVELAND RANGE INC.</b> 1130 East 179 <sup>th</sup> St. Cleveland, Ohio 44110-2574	
DECIMAL N/A	SCALE N/A	DRAWN BY: P.J.D.	APPROVED BY: -
ANGULAR N/A	TITLE FINAL ASSEMBLY CONVECTION ELECTRICAL HINGE RIGHT		
CK	DATE 11-05-91	DRAWING NUMBER 0-104521 PAGE 1 of 2	REV. -

## DIRECT STEAM KETTLE

### OPERATION

Ensure that there **is** an adequate steam supply to the kettle.

Turn the steam control valve to the full open position by turning the knob counter-clockwise, then allow the kettle to pre-heat.

NOTE: "When cooking egg and milk products, the kettle should NOT be preheated, **as** products of this nature adhere to hot cooking surfaces. These types of foods should be placed in the kettle before heating is begun.

Fill kettle with product to desired level

"When the produce has reached the desired temperature, regulate the heat, as required, by turning the steam control valve for less steam and therefore, a lower temperature.

When cooking is complete, close the steam control valve by turning the knob.

For kettle/steamer combinations: **If** the boiler in a steamer is supplying steam to a kettle, always heat the kettle first. After the kettle contents are heated, and the boiler's steam pressure returns **to** normal the steamer may be used. Pressure steamer compartments should be sequentially started, and preheated before cooking.

NOTE: As with cleaning food soil from any cookware, an important part of kettle cleaning is to prevent foods from drying on. For this reason, cleaning should be completed immediately after cooked foods are removed. Please refer to the "Care and Cleaning instructions for detailed kettle washing procedures.

### CARE AND CLEANING

Your kettle must be cleaned regularly to maintain its fast, efficient cooking performance, and to ensure its continued safe, reliable operation.

**WARNING:** Do not use chlorine base detergent.

1. Prepare a warm water and mild detergent solution in the kettle.
2. Remove food from inside- die kettle using a nylon brush, Do not use a metal bristle brush, as this may permanently damage the kettle's stainless steel surface.
3. Loosen food which is stuck to the kettle by allowing it to soak at a **low** temperature (simmer or low boil).
4. Tilt kettle forward to drain the wash water.
5. Rinse the kettle interior thoroughly, then drain rinse water.
6. **Leave** the **cover** and draw-off **valve** open when the kettle is not in use.
7. Using mild **soapy** water and a damp sponge, wash the exterior of the kettle, rinse, and dry.

NOTE: For more difficult cleaning applications, one of the following can **be** used: alcohol, baking soda, vinegar, or a solution of ammonia in water. Avoid the use of chloride cleansers, which may damage the kettle's stainless steel surface.

**WARNING:** Steel wool should never be used for cleaning the cooking chamber of the kettle. Particles of steel wool become embedded in the cooking surface and rust, and may corrode the stainless steel.

# STEAM CONTROL

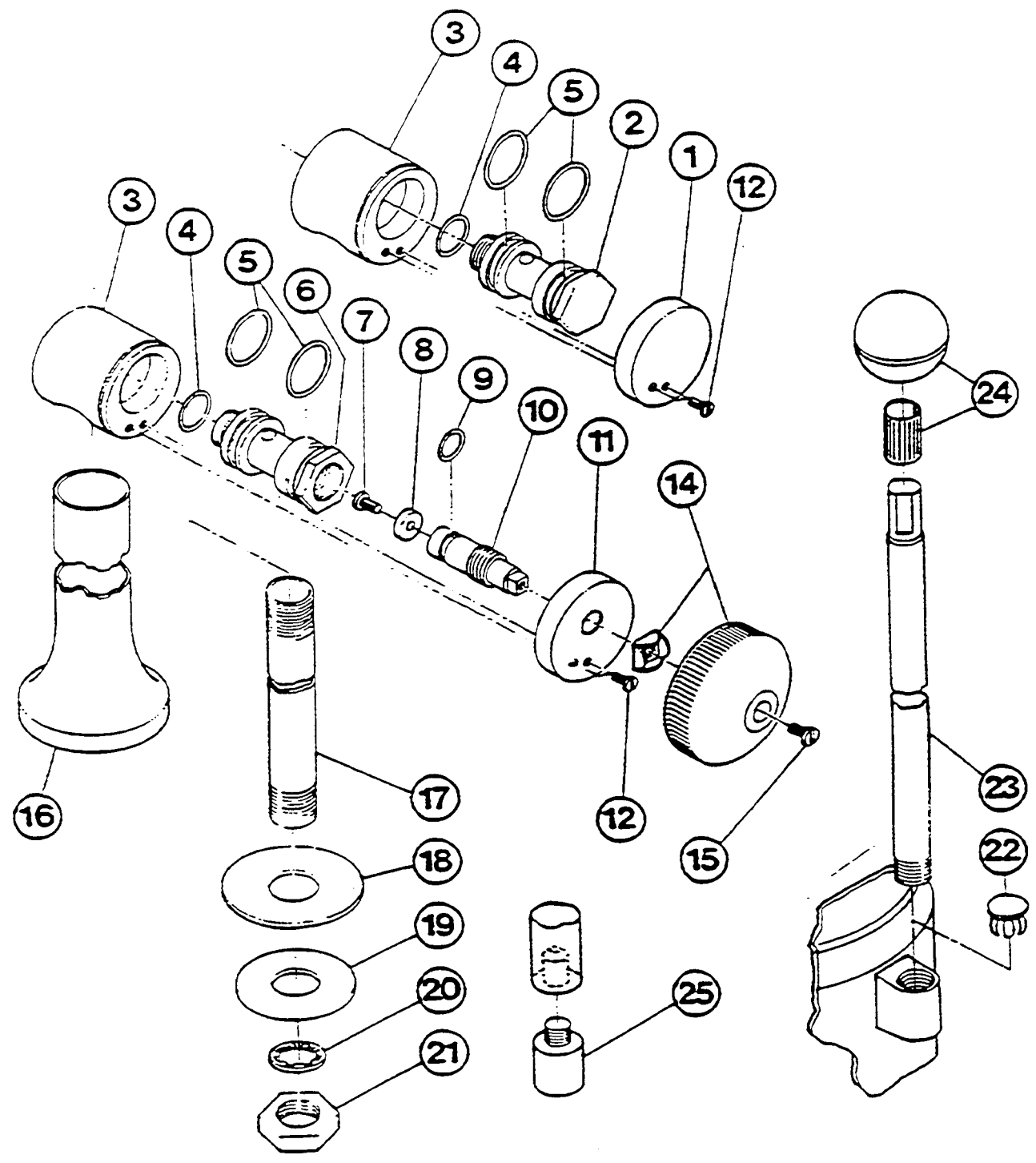

## PARTS LIST - STEAM CONTROL

ITEM NO.	PART NO.	DESCRIPTION	QTY.
1.	KE50458	End cap, condensate return	1
2.	KE50455-1	Trunnion, condensate return	1
3.	KE50456	Trunnion, housing	2
4-10.	SE00011	Steam inlet Trunnion assy.	1
4.	FA00017	"O" Ring	2
5.	FA00117	"O" Ring	4
6.	KE50460-1	Trunnion, steam inlet	1
7-10.	SE00029	Operating stem assy. stainless steel	1
7.	FA11089	Screw, 8-32x1/4-	1
8.	KE51713	Washer, operating stem	1
9.	FA00110	"O"Ring	1
10.	KE50459	Operating stem, stainless steel	1
11.	KE50457	End cap, steam inlet	1
12.	FA11054	Screw, 6-32 x 3/8"	2
14.	SE00028	Steam inlet knob assy.	1
15.	FA11092	Screw, 8-32 x 1/2"	1
16.	KE00200	Leg weldment ( 1 gal model)	2
	KE00197	Leg weldment ( 6 gal model)	2
	KE00198	Leg weldment (12 gal model)	2
	KE00199	Leg weldment (20 gal model)	2
17.	KE50465	Service pipe ( 1 gal model)	2
	KE52030	Service pipe ( 6 gal model)	2
	KE50463	Service pipe (12 gal model)	2
	KE50464	Service pipe (20 gal model)	2
18.	KE50467	Washer, foot	2
19.	FA30502	Washer, satin coal	2
20.	KE51898	Washer, lock	2
21.	FI00222	Lock nut, 1/2 NPS	2
22.	KE50475	Plug button	1
23.	KE50886	Handle ( 1 gal model)	1
	SK50051	Handle ( 6,12 gal model)	1
	KE50803	Handle (20 gal model)	1
24.	KE50151	Knob	1
25.	KE50474	Foot	1

## OPERATING CONTROLS

For your better understanding and confidence, the following explanation of the control system on this kettle is offered.

ITEM NO.	DESCRIPTION	FUNCTION
14	Steam Inlet Knob	Toms the steam on or off to the kettle.
23-24	Tilting Handle	Used for tilting the kettle.

## SERVICING GUIDE

This section contains information intended for use **by** Authorized Service Personnel only.

### A/ PROBLEM : Kettle heats too slowly or does not come to a boil.

Probable Cause	Remedy
1. Inadequate steam flow.	Check for correct steam using chart below. If kettle is connected to a -steamer and powered by a generator the units should be operated sequentially (kettle boiling first, then start <i>steamer</i> ).
2. Steam trap not operating property.	The trap should open periodically to dump condensate, then close, If it does not open or dose it should be cleaned or replaced.
3. Food batches are not always the same.	When checking make certain that the original state (ie. fresh or frozen) and quantity of food product is the same.

### B/ PROBLEM : The trunnion housing leaks steam.

Probable Cause	Remedy
1. Trunnion "O" rings are worn.	Replace "O" rings.

**STEAM FLOW RATING  
OF STEAM GENERATORS**

GAS INPUT BTU/HOOR	STEAM OTJTPCT LB&/HOOR	BOILER BS.
100,000	60	1.7
160,000	95	2£
200.000	325	3.6
250000	150	4.4
300,000	ISO	52
ELECTRIC KW INPUT		
18 KW	60	1.7
24 KW	70	20
27 KW	90	26
36 KW	320	35
48 KW	250	43

**STEAM FLOW RATE  
REQUIREMENTS FOR KETTLES**

Capacity GaL./Lit.	Fast Cooking	Medium Speed Cooking	Studs. Kettle
5/17	11	9	6
10/42	22	18	11
25/95	55	44	28
40/151	88	70	44
60/227	132	105	66

Note: Above shows lbs. per hour with 10-15 psig steam at the kettle. The use of higher steam pressures (20-25 psig) will reduce heat-up time 5 to 20 %.

# ELECTRIC STEAM GENERATOR (BOILER) ASSEMBLY - 2 PROBE TYPE 18 KW, 27 KW, 36 KW, & 48 KW (2, 3, & 4 HEATER ELEMENTS)

(OPTIONAL)

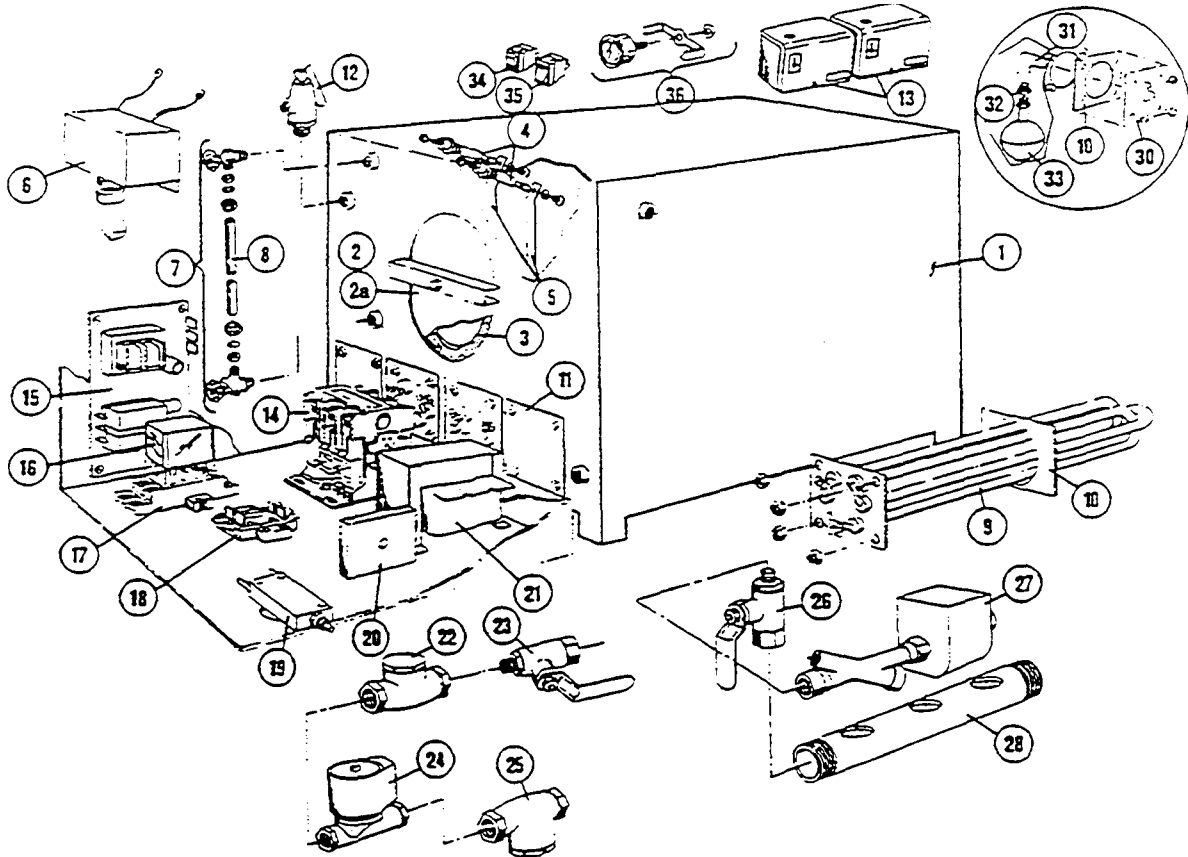

REFERENCE NUMBER	PART NUMBER	DESCRIPTION	REFERENCE NUMBER	PART NUMBER	DESCRIPTION
1	43894	Electric Boiler Shell only, with legs, hand hole plate assembly, mounting studs for 3" square-flanged heater elements	10	08216	Heater. 12 KW. 440/480 volt 1 phase
	44149	Electric Boiler Shell (43894) above, also including sight gauge, two probes and extensions with cover box.	11	08217	Heater 12 KW 600 volt 1 phase
2	40421	Hand Hole Plate Assembly including bar, nut, and gasket.	12	07128	Heater Gasket:
23	43748	Hand Hole Plate only	13	16546	3" Block-Off Plate
3	07106	Hand Hole Gasket. 4" x 6" oval	14	22131	15 psi Safety Valve
4	40462	Probe	15	22130	8 psi Safety Valve
5	101466	Probe Extension Set (set of two)	16	19947	Pressure Switch
6	52305	Probe Cover Box	17	03509	Contactor. 50 amp
7	40445	Water Gauge Set with Glass	18	03506	Contactor. 75 amp
	07108	Fiber Washer (2 required)	19	23198	Control Board, water level and LWCO
	23132	Gauge Glass Washer (2 required)	20	03524	Relay
8	07302	Gauge Glass Only. 6" long	21	03525	Relay Socket
9	08235	Heater. 9 KW. 208 volt. 3 phase	22	44168	Terminal Block. 2 pole
	08236	Heater. 9 KW. 220/240 volt. 3 phase	23	03202	Circuit Breaker, 1 amp
	08237	Heater. 9 KW. 440/480 volt. 3 phase	24	20478	Interval Timer. 3 minute
	08234	Heater. 9 KW. 600 volt. 3 phase	25	20535	Transformer. 150 VA
	08241	Heater. 9 KW. 208 volt. 1 phase	26	22102	Cheek Valve. 1/4"
	08242	Heater. 9 KW. 220/240 volt. 1 phase	27	03276	1/4" Ball Valve, water supply shut-off
	08243	Heater. 9 KW. 440/480 volt. 1 phase	28	22223	Solenoid Valve, water feed
	08244	Heater. 9 KW. 600 volt. 1 phase	29	19870	Line Strainer, 1/4"
	08165	Heater. 12 KW. 208/220 volt. 3 phase	30	03277	1/4" Ball Valve, manual drain
	08166	Heater. 12 KW. 230/240 volt. 3 phase	31	22221	Solenoid Valve, boiler drain
	08167	Heater. 12 KW. 440/480 volt. 3 phase	32	13252	Drain Manifold
	08163	Heater. 12 KW. 600 volt. 3 phase	33	45006	Low Water Cut-Off Assembly (California only)
	08214	Heater. 12 KW. 208/220 volt. 1 phase	34	41943	LWCO Mounting Plate (California only)
	08215	Heater. 12 KW. 230/240 volt. 1 phase	35	05253	Brass Street Elbow (California only)
			36	02623	Reducing Bushing. 1/2" x 1/4" (California only)
				19995	Float Switch. LWCO (California only)
				19993	DPDT Power switch
				19994	SPST Momentary contact reset switch
				07167	Pressure gauge. 0-30 psi. 1 1/2"

Manufacturer reserves right of design improvement or modification as warranted.

# HEATER AND CONTACTOR WIRING SCHEMATICS FOR SOLID STATE ELECTRIC STEAM GENERATORS

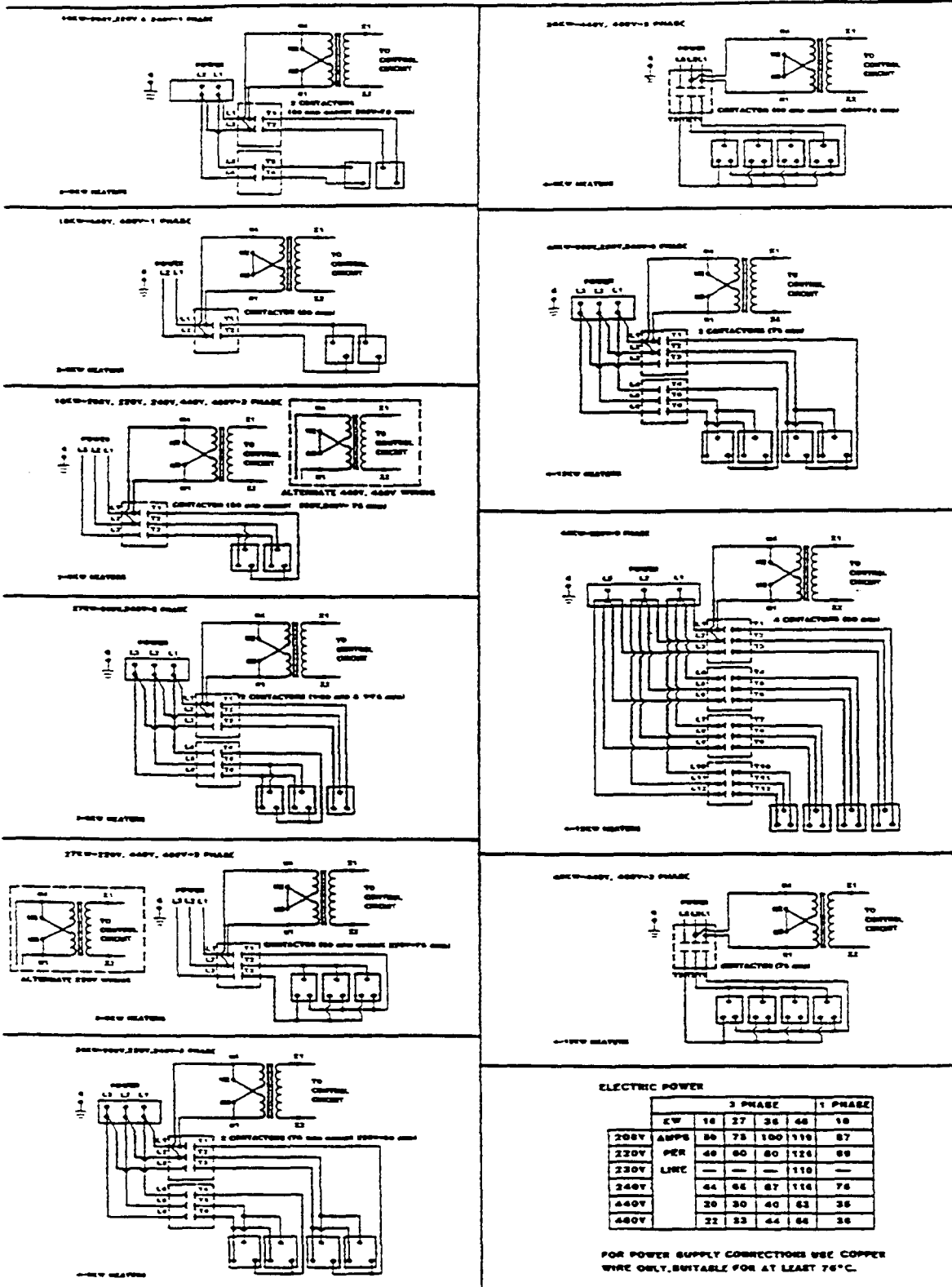

**ELECTRIC POWER**

		3 PHASE				1 PHASE
		CW	18	27	36	48
200V	AMPS	50	75	100	118	87
230V	PER	40	60	80	126	88
230V	LINE	—	—	—	110	—
240V		44	66	87	116	76
480V		20	30	40	63	36
480V		22	33	44	64	36

FOR POWER SUPPLY CORRECTIONS USE COPPER WIRE ONLY, SUITABLE FOR AT LEAST 75°C.



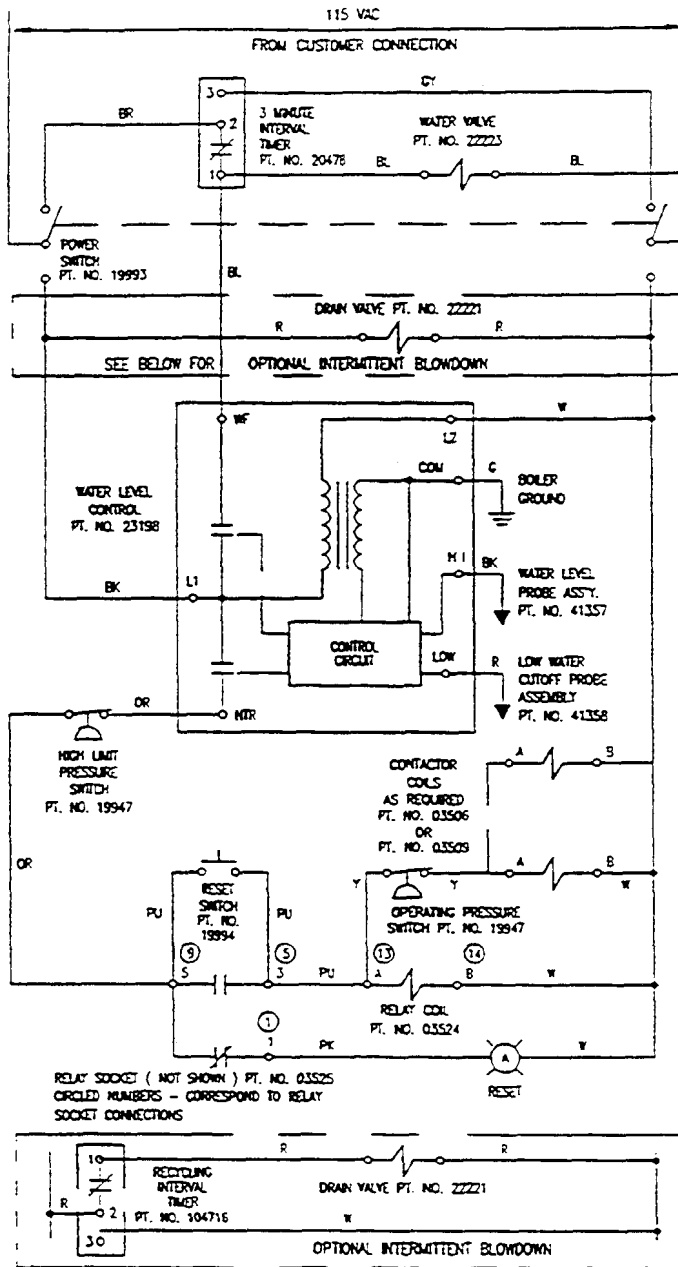

ELECTRIC GENERATOR CONTROL WIRING  
(INTERMITTENT BLOWDOWN OPTIONAL)

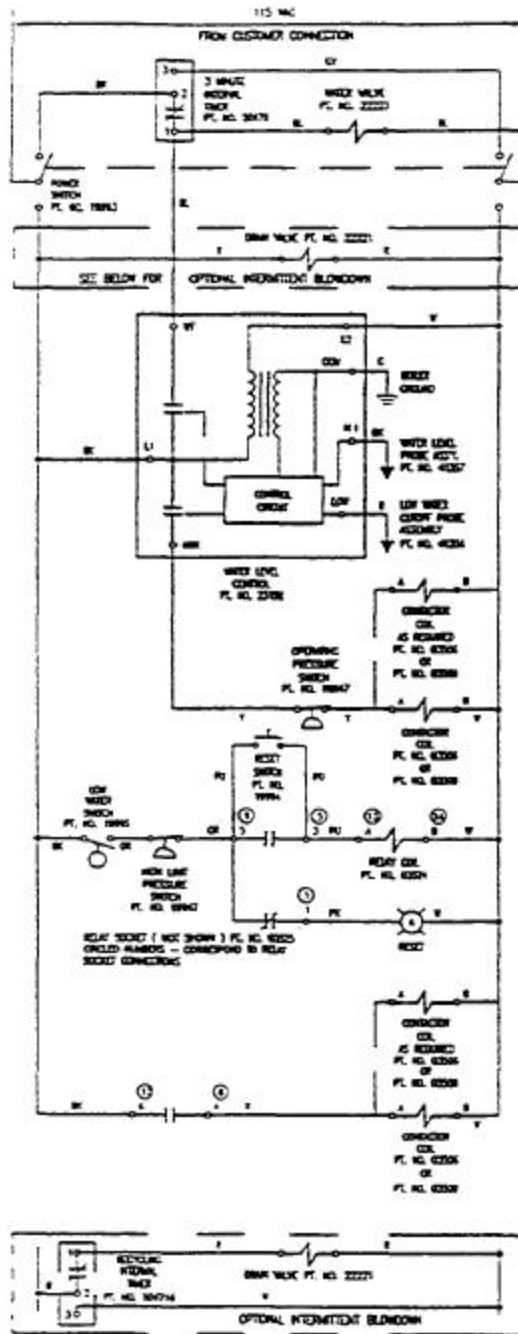

Electric Models with Secondary Low Water Cutoff Built to California Code

**GAS STEAM GENERATOR (BOILER) ASSEMBLY - 2 PROBE TYPE**  
**SMALL: 100,000 BTU (2 Burners) & 200,000 BTU (4 burners)**  
**LARGE: 250,000 BTU (5 burners) & 300,000 BTU (6 burners)**

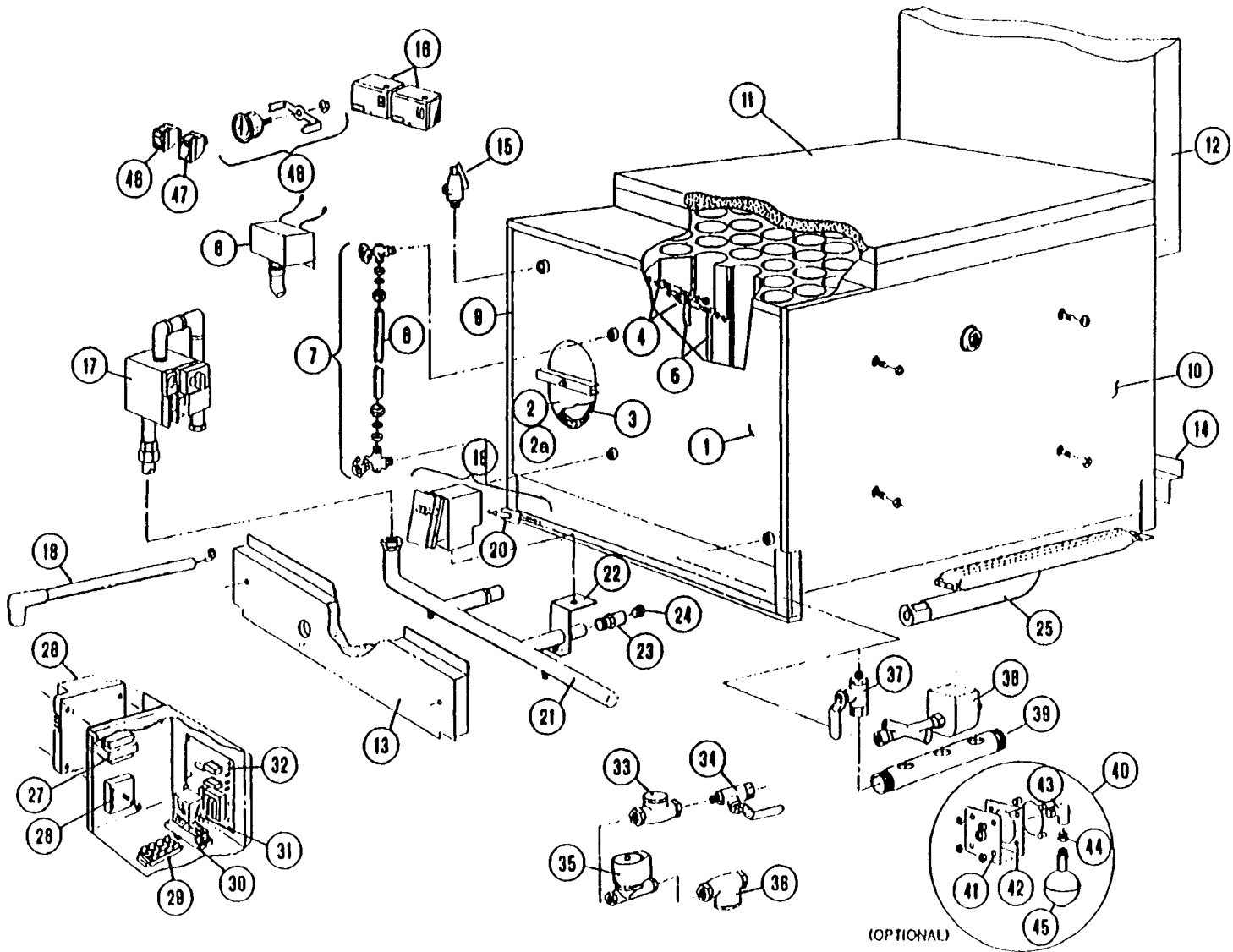

Manufacturer reserves right of design improvement or modification, as warranted.

**GAS STEAM GENERATOR (BOILER) ASSEMBLY - 2 PROBE TYPE SMALL: 100,000  
BTU (2 Burners) & 200,000 BTU (4 burners) LARGE: 250,000 BTU (5 burners) &  
300,000 BTU (6 burners)**

REFERENCE NUMBER	PART NUMBER	DESCRIPTION	REFERENCE NUMBER	PART NUMBER	DESCRIPTION
1	43898	Small boiler shell only (100.000/200.000 BTU). with legs. studs. Hand hole plate assembly and top flue bracket.		44156	5-burner rear burner support
	43899	Large boiler shell only (250.000/300.000 BTU), with legs. studs. hand hole plate assembly. and top flue bracket.	15	44157	6-burner rear burner support
	44173	Small boiler shell (43898) above, also including insulation panels, top flue collector with insulation, sight gauge, two probes and extensions with cover box.	16	22130	Safety valve. 6 psi
	44172	Large boiler shell (43899) above, also including insulation panels, top flue collector with insulation. sight gauge, two probes and extensions with cover box.	17	22131	Safety valve. 15 psi
2	40421	Hand hole plate assembly including bar. nut, and gasket.	18	19947	Pressure switch
2a	43748	Hand note Plate only	19	22228	Gas control valve. natural gas. small boiler (100.000/200.000 BTU)
3	07106	Hand hole gasket. 4' x 6' oval	20	22230	Gas control valve. natural gas. large boiler (250/300.000 BTU)
4	40462	Probe	21	22231	Gas control valve. L.P. gas. small and large boilers (100.000/200.000 and 250,000/300.000 BTU)
5	101466	Probe extension set (set of two)		44169	Igniter cable
6	52305	Probe cover box	19	44096	Igniter box assembly with ignitor
7	40445	Water gauge set with glass	20	05101	Igniter electrode
	07108	Fiber washer (2 required)	21	40918	Gas manifold. 2-burner
	23132	Gauge glass washer (2 required)		40920	Gas manifold. 4-burner
8	07302	Gauge glass only 6' long	22	40921	Gas manifold. 5-timer
9	44043	Left side insulation panel assembly	23	40922	Gas manifold. 6-burner
	440431	Left side insulation panel assembly for LP. gas - 100.000/200.000 BTU boiler only	22	52602	Manifold alignment bracket
10	44042	Right side insulation panel assembly	23	19632	Orifice holder
	440421	Right side insulation panel assembly for LP. gas - 100.000/200.000 BTU boiler only	24 25	15453	Burner orifice, natural gas
11	42398	Top flue collector with insulation, for small boiler (100.000/200.000 BTU)		15450	Burner orifice. L.P. gas Burner
	42399	Top flue collector with insulation, for large boiler (250.000/300.000 BTU)	26	03546	Spark ignition control module
	42360	Internal flue riser assembly for small boiler (100.000/200.000 BTU)	27	20528	24 volt transformer
	42361	Internal flue riser assembly for large boiler (250,000/300.000 BTU)	28	20478	Internal time 3 minute
13	44134	2-burner front baffle assembly - natural gas	29	44164	Terminal block- 4 pole
	44135	4-burner front baffle assembly - natural gas	30	03525	Relay socket
	40840	5-burner front baffle assembly - natural gas	31	03524	Relay
	40842	6-burner front baffle assembly - natural gas	32	23198	Control board, water level and IWCO
	44150	Front burner baffle assembly for LP. gas - 100.000/200.000 BTU boiler only (not shown)	33	22102	Check valve. 1/4"
	44170	Right side burner baffle assembly for L.P. gas 100.000/200.000 BTU boiler only (not shown)	34	03276	1/4" Ball valve, water supply shut off
	44171	Left side burner baffle assembly for L.P. gas 100.000/200.000 BTU boiler only (not shown)	35	22223	Solenoid valve, water feed
14	44153	2-burner rear burner support	36	19870	Line strainer. 1/4"
	44155	4-burner rear burner support	37	03277	1/4" Ball valve, manual drain
			38	22221	Solenoid valve, boiler drain
			39	13252	Drain manifold
			40	45006	Low water cut-off assembly (California only)
			41	41943	LWCO mounting plate (California only)
			42	07128	Gasket (California only)
			43	05253	Brass street elbow (California only)
			44	02623	1/2"-1/4" Brass reducing bushing (California only)
			45	19995	Float switch. IWCO (California only)
			46	19993	DPOT Power switch
			47	19994	SPST Momentary contact reset switch
			48	07167	Pressure gauge. 0-30 psi. 1 1/2"

Manufacturer reserves right of design improvement or modification, as warranted.

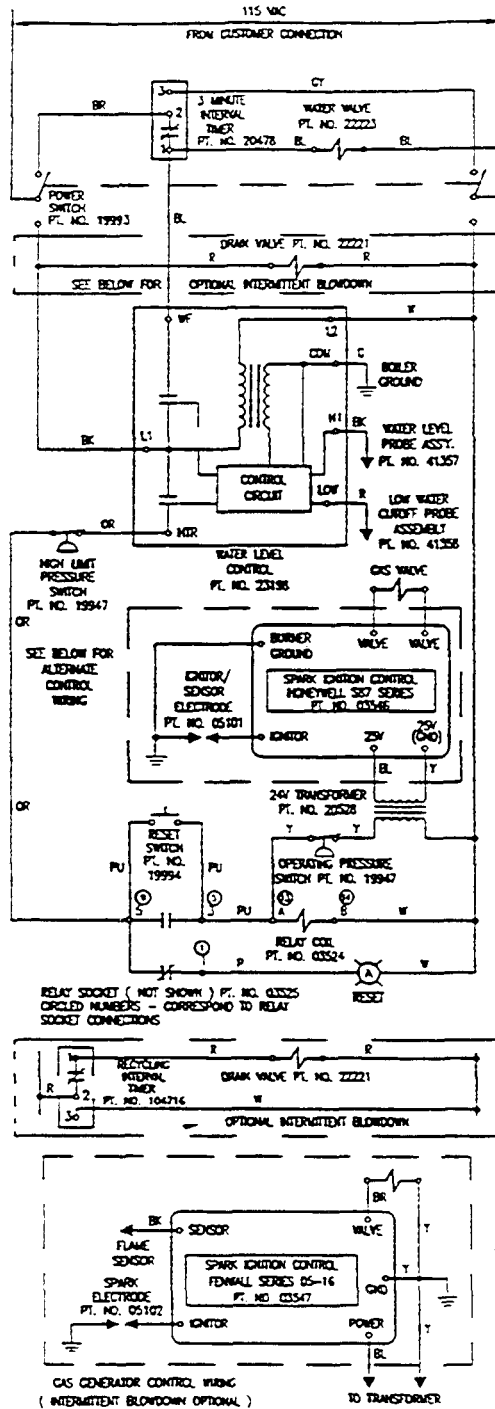

Gas Models

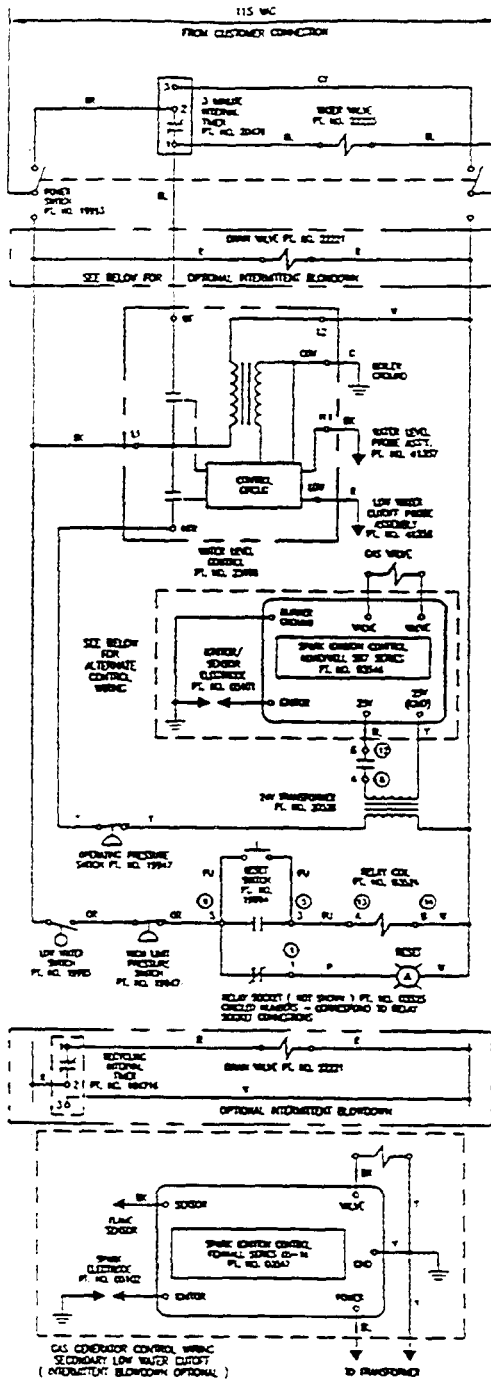

Gas Models with Secondary Low Water Cutoff

# STEAM COIL GENERATOR (BOILER) ASSEMBLY 2 PROBE TYPE

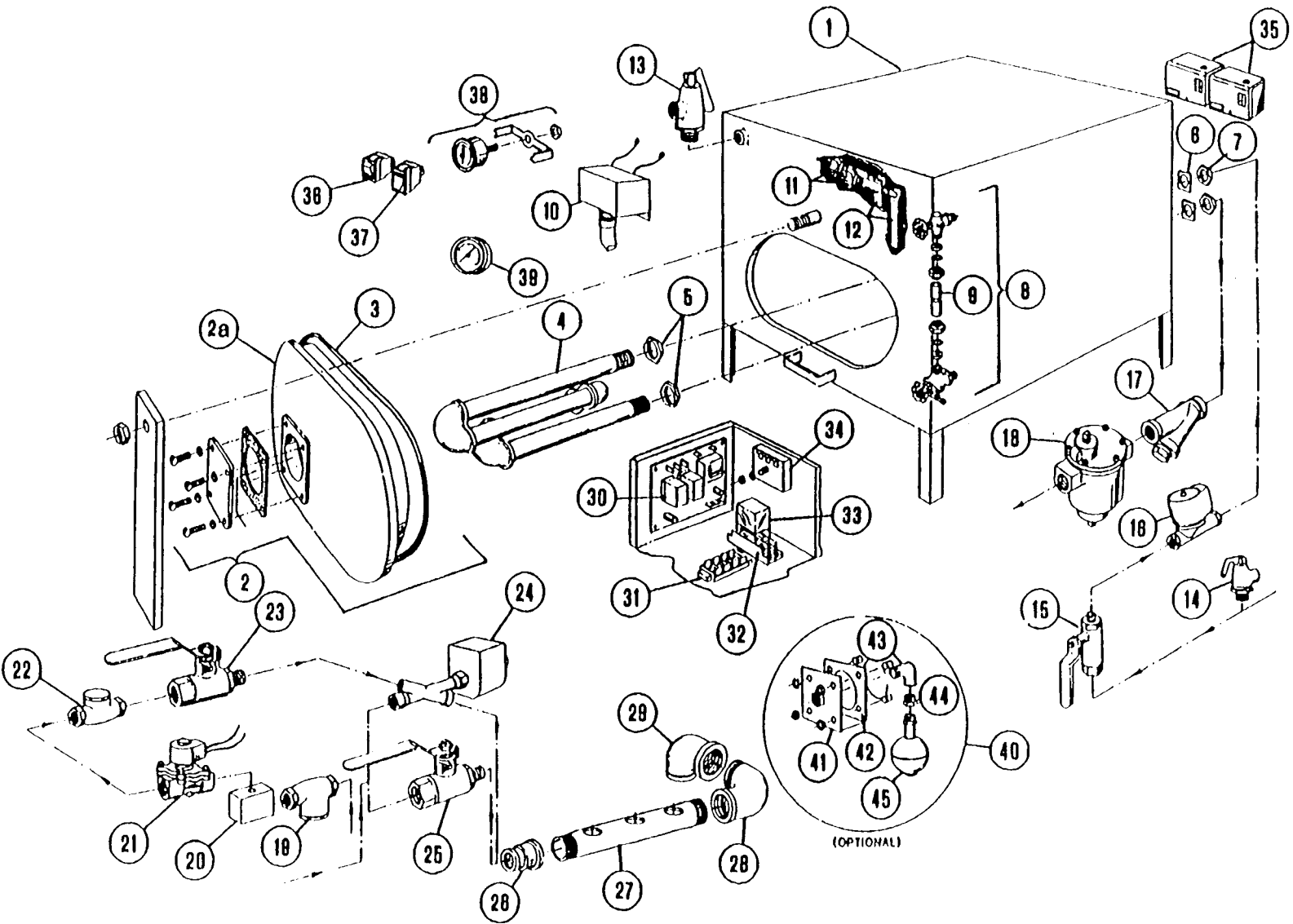

Manufacturer reserves right of design improvement or modification, as warranted.

## STEAM COIL GENERATOR (BOILER) ASSEMBLY 2 PROBE TYPE

REFERENCE NUMBER	PART NUMBER	DESCRIPTION
1	43977	Steam Coil Boiler Shell with Legs, Sight Gauge, Steam Coil, Hand Hole Plate Assembly, 2 Probes and Extensions with Cover Box.
2	100636	Hand Hole Plate Assembly
2a	16545	Hand Hole Plate Only
3	07116	Hand Hole Gasket
4	40401	Steam Coil Assembly
5	14612	1 1/4" Brass Locknut
6	23135	3 1/4 " Square Flat Washer
7	14611	1 1/4 " Steel Locknut
8	40446	Water Gauge Set with Glass
	07108	Fiber Washer (2 required)
	23132	Gauge Glass Washer (2 required)
9	07301	Glass Only—10 1/2" Long
10	52305	Probe Cover Box
11	40462	Probe with Lockwasher and Screw
12	101466	Probe Extension Set (2)
13	22130	Safety Valve—8 psi
	22131	Safety Valve—15 psi
14	22232	Safety Valve—55 psi
15	03277	3/4" Ball Valve
16	22193	3/4" Steam Solenoid Valve
17	19872	3/4" Line Strainer
18	20555	3/4" Bucket Trap
19	19870	1/4" Line Strainer
20	06226	Brass Elbow, 90°, Special
21	22223	Solenoid Valve, Water Feed
22	22102	Check Valve, 1/4"
23	03276	3/4" Ball Valve, Water Supply Shut Off
24	22221	Solenoid Valve, Boiler Drain
25	03277	3/4" Ball Valve, Manual Drain
26	03616	Reducing Bell
27	13252	Drain Manifold
28	05292	Street Elbow, 90°
29	05238	Elbow , 90°
30	23198	Control Board, Water Level and LWCO
31	44165	Terminal Block, 4-pole
32	03525	Relay Socket
33	03524	Relay
34	20478	Interval Timer, 3 Minute
35	19947	Pressure Switch
36	19993	DPDT Power Switch
37	19994	SPST Momentary Contact Reset Sw itch
38	07168	Pressure Gauge, Back Mount, 0-30 psi
39	07166	Pressure Gauge, Back Mount, 0-100 psi
40	45006	Low Water Cut Off Assembly (California Only)
41	41943	LWCO Mounting Plate (California Only)
42	07128	Gasket (California Only)
43	05253	Brass Street Elbow (California Only)
44	02623	1/2"-1/4" Brass Reducing Bushing (California Only)
45	19995	Float Switch. LWCO (California Only)



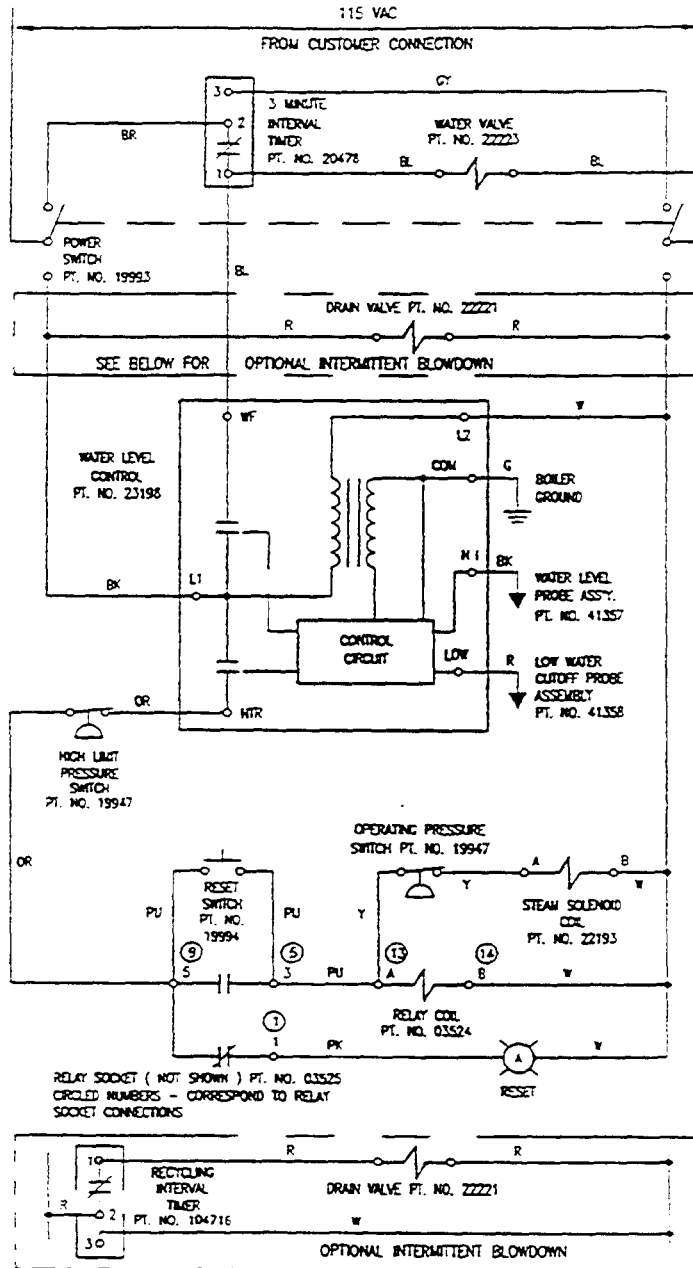

STEAM COIL GENERATOR CONTROL WIRING  
(INTERMITTENT BLOWDOWN OPTIONAL)

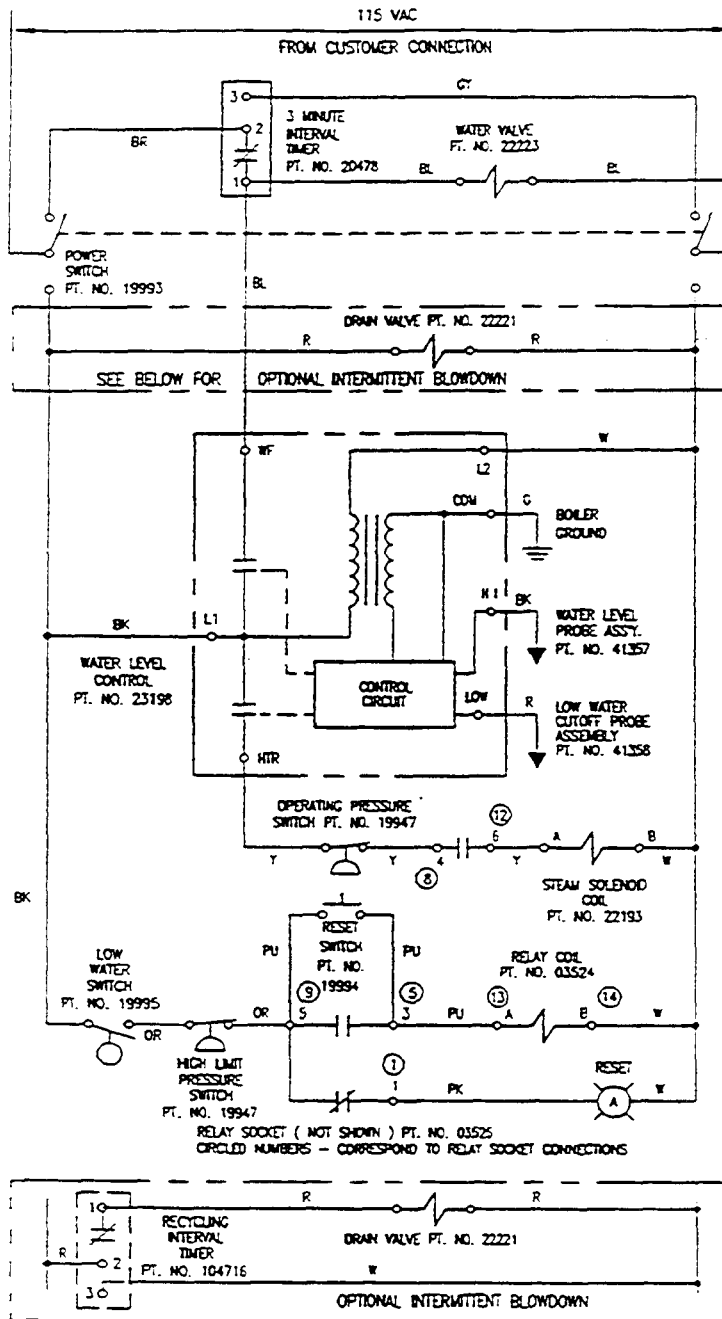

STEAM COIL GENERATOR CONTROL WIRING  
 SECONDARY LOW WATER CUTOFF  
 ( INTERMITTENT BLOWDOWN OPTIONAL )

Steam Coil Models with Secondary Low Water Cutoff

## STEAM GENERATOR (2 PROBE TYPE) MAINTENANCE PROCEDURES

**CAUTION: Service on the generator must be performed only by a trained and experienced service technician, thoroughly familiar with servicing steam generators. No work should be done on the steam generator while it is pressurized or hot. Be sure all energy sources are shut off before the start of any work.**

The steam generator must be drained under pressure (blowdown) after a maximum of 8 hours of use. If the generator's feedwater contains more than 300 parts per million of total dissolved solids, the generator must have a blowdown after each 4-6 hours of use. "Blowdown" means the generator must be drained under pressure.

THE GENERATOR "BLOWDOWN" IS PERFORMED BY SHUTTING OFF THE UNITS RED-LIGHTED "POWER" SWITCH WHILE THE GENERATOR IS AT NORMAL OPERATING PRESSURE. WHEN THE BOTTOM OF THE "POWER" ROCKER SWITCH IS PUSHED, ITS RED LIGHT GOES OUT. AND THE DRAIN VALVE AUTOMATICALLY OPENS, DRAINING THE GENERATOR. AN AUTOMATICALLY-TIMED SOLENOID VALVE WILL FLUSH THE DRAIN FOR 3 MINUTES. THEN SHUT OFF. AFTER 3 MINUTES, THE UNIT CAN BE RESTARTED.

Even though the "Blowdown" is performed faithfully each day, it will still be necessary to have a qualified service technician periodically inspect the inside of the generator for scaling or pitting. The generator's hand hole plate should be removed at regular intervals, so that it and the inside of the generator can be inspected. The hand hole plate should be cleaned and examined each time it is removed. If the hand hole plate is chipped or cracked, or over three years old, install a new one. A new hand hole gasket should always be installed.

Scaling indicates a high concentration of dissolved minerals in the feed water. Pitting indicates an excess acid condition. The best way to reduce servicing time and to assure a long generator life is to provide feed water that is low in mineral content and low in gas content. Water that is fit to drink can still be high in impurities that are highly detrimental to a steam generator. Consult the state department of water for an on-the-premises water analysis and for recommendations concerning steam generator feed water treatment (if required), in order to remove or reduce harmful concentrations of minerals.

**CAUTION:** Never tighten the hand hole plate nut when the steam generator is in use, hot, or otherwise pressurized. Never tighten nut over 15 foot-pounds torque. Over tightening may cause uneven stress, which may result in the weakening and possible breakage of the plate.

The "Blowdown" procedure will not completely remove the mineral deposits that adhere to the top of the generator.

It will be necessary to periodically have scale accumulations removed from the inside of the steam generator by a qualified service technician. Only a U.S.D.A. approved acid cleaner should be used to descale the generator.

Descaling should be done once a year, but in poor water (highly mineralized) areas it may be needed two or three times a year.

Failure to periodically remove scale from the inside of the generator will result in greatly reduced generator life.

Check the safety valve once a month while the steam generator is pressurized. Test by pulling the safety valve lever. The valve must open freely and snap closed when released. If it does not, or if it drips constantly, a new safety valve is needed.

If the steam generator is to be left idle for three months or more, it should be drained and dried out and the hand hole plate left off.

WATER QUALITY REQUIREMENTS — 2-PROBE TYPE STEAM GENERATOR PROTECTION AND MAINTENANCE

A steam generator, or boiler, unlike other types of water-using kitchen equipment distills the water in order to make steam. Nearly all feed-water sources contain dissolved minerals in varying degrees of concentration. As this water is boiled, pure steam rises from its surface, upward to the cooking compartment(s), leaving minerals behind, that can become harmful to the steam generator. If minerals are allowed to accumulate inside the steam generator, they will solidify as a scale. Then, malfunctioning will occur, and serious equipment damage may result.

The use of good Quality generator feed water is the responsibility of the owner/user. The use of poor quality feed water could void equipment warranties. The *mini*-mum treatment required in most areas is water softening, although local water conditions may require more intensive pretreatment than simply a water softener.

Scale problems occur when feed water is high in hardness, total dissolved solids, silica, and alkalinity. Water softening will only reduce the water's hardness, which is the presence of dissolved salts of magnesium and calcium. Water softening will not affect the multitude of other minerals found in most water supplies. Because generator scale is the result of the precipitation of many minerals, the best property to control, for generator feed water, is total dissolved solids, not just hardness.

The recommended minimum water quality standards, whether untreated or pre-treated, based upon 8 hours of use per day, and a Daily Blowdown are as follows:

TOTAL DISSOLVED SOLIDS	less than	60 parts per million
TOTAL ALKALINITY	less than	27 parts per million
SILICA	less than	13 parts per million
pH FACTOR	greater than	7.5

Consult the state department of water or a local water treatment specialist for an on-the-premises water analysis and for recommendations concerning steam generator feed water treatment (if required), in order to remove or reduce harmful concentrations of minerals.

If the recommended water quality requirements are met without supplemental treatment or if treatment is applied, resulting in feed water quality meeting the prescribed standards, the steam generator will need to be blown down only once every 8 hours. In addition, the inside of the generator requires an inspection (for excessive lime accumulation) only once every six months. Chemically descale the generator as required.

If a pre-treatment unit cannot be installed, and the recommended water quality requirements are not met the following procedures should be followed, in order to achieve maximum steam generator service life. The steam generator should be blown down after each 4-6 hours of use. Have the steam generator inspected, inside and outside, by a qualified technician every three months. If the inside of the generator is heavily coated with scale, have it chemically descaled by a qualified service technician.

INSTRUCTIONS FOR CHEMICALLY DESCALING 2-PROBE TYPE STEAM GENERATORS

**WARNING: Steam under pressure may cause serious injury and bodily harm when it is accidentally or carelessly released. Improper handling of acid could cause serious, permanent injury. Therefore, service of the steam generator should only be performed by trained and experienced personnel, thoroughly familiar with servicing generators.**

There are a number of commercial descaling chemicals available, produced by various manufacturers. Those utilizing a sulfamic acid base, which can be identified by its powdered form are safe and compatible with our food preparation equipment it is imperative that the acid used for descaling be FDA approved, for use in food preparation equipment. Various manufacturers may include additional chemicals to increase potency, and therefore, instructions for a specific brand should be followed carefully. If instructions are not provided with the descaling chemical you purchase, the following general guidelines may be followed.

**WARNING: Exercise care when handling acid. Avoid contact with skin, eyes, or clothing. Wear safety glasses or face shield, along with rubber gloves and rubber apron. In case of exposure to clothing, remove clothing and flush with water. In case of exposure to skin or eyes, flush with water for 15 minutes and get immediate medical attention. Do not take internally. Keep out of the reach of children.**

Be sure the generator has been drained, de-pressurized, and is cool. Open the hand hole access plate on the front of the generator and place approximately 8-10 pounds of sulfamic acid inside the generator. Put a new hand hole gasket on the hand hole plate, and replace the hand hole plate, tightening the bar and nut assembly to a maximum of 15 foot pounds torque. The generator must be completely filled with water (fill the generator beyond its normal, automatic fill point of 2/3 up in the sight gauge). This can be accomplished by temporarily disconnecting the wire from the water level probe at the water level control board. The board is marked "HI" at this connection point. Turn the main on-off rocker switch to the "ON" position, then close the manual water feed valve when the generator is completely filled. Leave the on-off rocker switch in the "on" position to prevent the generator from automatically draining. Reconnect the probe wire to the "HI" terminal of the water level control board. Let the solution stand for several hours, then flush with water. Rinse with a solution of bicarbonate of soda to neutralize any acid residue, and again, flush with water. Be sure to reconnect the wire to the water level control board and to open the manual water feed valve.

**CAUTION: Never tighten the hand hole plate nut when the steam generator is in use, hot, or otherwise pressurized. Never tighten nut over 15 foot pounds torque. Over tightening may cause uneven stress, which may result in the weakening and possible breakage of the plate.**

## Descaling Procedure for Two-Probe Steam Generators

The steam generator should be descaled at least once a month, depending on scale buildup. If you have serious steam generator scale buildup, install a water treatment system for the steamer-Cleveland Range recommends use of the descaling kit. part number [40891](#), which consists of powdered sulfamic acid. Full descaling may take several hours, or more than one acid process. Perform descaling until all scale buildup is cleaned out.

Follow hazard and leak cleanup procedures on add container label. If the label is not readable or has been removed, refer to the following hazard and emergency instructions as a minimum safety precaution-

### THESE INSTRUCTIONS ARE FOR USE WITH POWDERED SULFAMIC ACID ONLY.

- Health Hazard Data, Effects of Overexposure - Product is extremely irritating to the eyes and may result in eye burns. Product is severely irritating to skin and can result in skin burns; repeated or prolonged contact with more dilute solutions may result in dermatitis. Aerosol mist or vapors are irritating to respiratory tract, eyes and throat. Prolonged exposure to high concentration may result in pulmonary edema. If ingested, may result in abdominal hemorrhage with severe abdominal pain, nausea, vomiting or loss of consciousness; necrosis of stomach and gastrointestinal tract may also occur.
- Emergency and First Aid Procedures - In case of eye contact, immediately flush eyes with plenty of water for at least 15 minutes. Seek medical aid- In case of skin contact immediately wash with soap and plenty of water for at least 15 minutes while removing contaminated clothing. Seek medical aid. If inhaled, remove to fresh air. If not breathing, give artificial respiration. If breathing is difficult, give oxygen. Seek medical aid. If swallowed, do not induce vomiting. Give large quantities of water. Seek medical aid. Never give anything by mouth to an unconscious person.
- Spill or Leak Procedures - Contain spill. Cover the contaminated surface with sodium bicarbonate or a soda ash-slaked lime mixture

(50-50). Mix and add water if necessary to form slurry. Scoop up slurry and wash residue down drain with excess water. Wash site with soda ash solution-

### WARNING

The powdered sulfamic acid in descaling kit [40891](#) can be harmful if not handled properly. Follow these basic safety rules for handling and using acid.

Wear protective clothing when mixing or applying chemical cleaners. Wear rubber gloves, mask and approved cup-type goggles.

Avoid breathing fumes. If acid comes in contact with skin, flush immediately with large quantities of cold water. Remove contaminated clothing.

If chemical contacts eyes, flush with cold water for a minimum of 15 minutes. Get immediate medical attention.

If chemical is swallowed or ingested, follow instructions on the chemical container. Get immediate medical attention.

### CAUTION

Do not scrape heating elements with a solid tool.

If the steamer is turned off, energize the steamer by pressing the POWER switch to on- Allow time for the steam generator to fill (3 to 4 minutes). This assures that blowdown occurs:

1. Press the POWER switch to off.
2. Press the TIMED/MANUAL switch to TIMED. Set timer to 0.
- 3- After completion of blowdown (3 minutes), turn off power at the main disconnect Switch
4. Allow time for the steam generator and compartment to cool down.

## Descaling Procedure (continued)

5. Turn off power at main disconnect switch-
6. Remove handhole plate.
7. Pour powdered sulfamic acid into the steam generator.
8. Replace handhole plate.
9. Turn water off at manual 1/4-inch ball valve on base.
- 10- Remove control box cover.
11. Disconnect black probe wire from water board-
12. Turn power on at the main disconnect switch.
13. Turn POWER switch on base unit to on.
14. Turn water on at manual 1/4-inch ball valve.
15. Let steam generator fill to proper level (2/3 the way up the sight glass), then turn off the manual fill valve to stop generator fill.
16. Start steam generator heat cycle. Let generator heat up until it is hot to the touch.
17. When the steam generator is hot turn off the gas package valve.
18. Turn on the generator fill manual valve and, while holding open the safety valve (pop off valve), let the generator keep filling until water comes out the safety valve.
19. Turn off the manual ball valve to the fill assembly.
20. Let steam generator descale overnight or for any eight (8) hour period.  
After eight hour period:
21. Drain the generator with the manual 3/4-inch ball valve.
22. Turn off electric power at the main disconnect switch. 23. Remove handhole plate.
24. Pour in neutralizer (3 or 4 tablespoons of baking soda).
25. Install handhole plate and tighten the bar and nut assembly to a maximum of 15 foot pounds torque.
26. Close the 3/4-inch manual drain valve.
27. Open 1/4-inch manual ball valve to fill assembly.
28. Turn electrical power on at main disconnect switch.
29. Turn POWER switch on base unit to on.
30. Let unit fill until water comes out the safety valve.
31. Close 1/4-inch manual ball valve on fill assembly.
32. Let unit set for 5 minutes.
33. Open the 3/4-inch drain valve to blow down and drain the steamer.
34. Turn POWER switch on base unit to off.
35. Turn power off at the main disconnect switch.
36. Reconnect black probe wire to water board.
37. Replace control box cover.
38. Turn on manual ball valve to fill assembly.
39. Close 3/4-inch drain ball valve.
40. Turn power on at the main disconnect switch. 43- Turn POWER switch on base unit to on.
42. An amber light on the STEAM switch will light when the water reaches the low cut-off probe.
43. Turn on the STEAM switch to start the steam generator for a test.
44. When pressure reaches 9 psi on the pressure gage located on the steam generator console, open the manual drain valve to blow down the generator under pressure and test the low water cut-off.
45. Close the manual drain valve.
46. Refill generator and when amber light comes on, turn on the steam switch to start the steam generator for a test.
47. When the unit reaches 9 psi, turn off POWER switch on console to test blowdown.
48. After blowdown has completed, refill generator and restart heat cycle.
49. Unit is now ready for use.

## WATER LEVEL CONTROL SYSTEM

### TROUBLESHOOTING AND REPAIR

#### General Description of Operation:

The Cleveland Range water level control, P/N [23198](#), is designed to maintain operating water level in Cleveland Range steam generators and to ensure that the heat source is only operated when the generator water level is above a specified minimum level. The sensing technique for the control relies on the fact that tap water is conductive to electricity; if two metal electrodes are immersed in a bath of water, electric current can flow between the electrodes using the water as a conductor. Water is not a good conductor, like copper, but is conductive enough to be measured using appropriate electronic circuitry.

The Cleveland Range control is a two probe system having two metallic probes (LOW and HI) for sensing water in the generator; a COM terminal is placed on the tank. The LOW probe is placed so that it will come in contact with the water when the water level is just above the desired water level, enough to protect the heat source. If the water is of sufficient level and the LOW probe is in the water, a small electrical current provided by the level control electronics will flow between the probe and COM; this flow will be sensed by the electronics which in turn will activate the "HEAT" relay to apply AC power to the HEAT terminal on the control circuit board.

Similarly, the HI probe is located at the desired water level fill (above the LOW probe level) so that when the water level has reached the desired fill level electrical current will flow between the HI probe and COM. The action of this probe is reversed from the previous situation so that when water reaches the HI probe, the WATER fill relay is deactivated so that AC power to the WF is turned off. When the water level drops below the HI probe, the WF terminal will be re-energized after a five second delay. The time delay is to prevent bubbling or turbulence in the generator from chattering to WATER fill relay or the water valve solenoid.

The control runs on 120 vac and is transformer isolated so that the probes and the electronics are run at low voltage and are not common to the AC power line.

Note that in many Cleveland Range generators both sensing probes are inserted from the front top of the unit down into the generator. In this case, the LOW probe will be the longest and the HI probe will be the shortest.

A) SYMPTOMS OF WATER LEVEL CONTROL RELATED PROBLEMS:

- 1) Boiler overfills or floods
- 2) Boiler dry fires (system under fills or doesn't fill)
- 3) Boiler doesn't fill at all
- 4) Water fill solenoid chatter
- 5) Heater contactor chatter
- 6) Fills but cuts out on LOW WATER before filling again
- 7) Overfills but does not heat
- 8) Fills but does not heat

B) POSSIBLE CAUSES:

- 1) Inoperative water level control circuit board (P/N [23198](#))
- 2) Incorrect or damaged wiring to probes
- 3) Incorrect or damaged wiring from water level -board to loads
- 4) Damaged probes
- 5) Probes shorted together
- 6) Scale build-up on probes

C) FAULT ISOLATION PROCEDURE:

Equipment Required: Volt/Ohmmeter (VOM) or Multimeter

STEP	TEST	RESULT	REMEDY
1.	Is power applied to the control circuit board? Measure L1-L2 at the board to be 120 VAC + 15V.	Yes	Go to Step #2
		No	Correct external supply problem
2.	Remove two AC power wires from control board and connect ohmmeter to control board power terminals. Is resistance between 100-1000 ohms?	Yes	Reconnect power and go to Step #3
		No	Replace control board P/N <a href="#">23198</a> (inoperative transformer)
3.	Visually inspect probe wiring for damaged or broken wires or loose or missing terminals at either end. Is wiring visually OK?	Yes	Go to Step #4
		No	Replace wiring as required



<u>STEP</u>	<u>TEST</u>	<u>RESULT</u>	<u>REMEDY</u>
		Yes	Go to Step #5
4.	Are the following connections made correctly? A) COM input on board to boiler ground B) LO input on board to long length "LO" probe C) HI input on board to short "HI" probe	No	Correct probe wiring as required (see Figure 1)
		Yes	Go to Step #6
5.	Temporarily disconnect the wire from the HTR terminal so that the heat source will not operate. Is the heat source off?	No	Check heat source and wiring in cooker
		Yes	Go to Step #7
6.	With HTR still disconnected, disconnect -the LOW wire at the LOW terminal of the control board. Measure the AC line voltage between the HTR and L2 terminals on the control board. Is the voltage 0 vac? NOTE: Digital meters may read a few volts due to their high input impedance; this should be considered as 0 vac.	No	Replace water level control P/N <a href="#">23198</a>
		Yes	Reconnect HTR & LOW wires and go to Step #8
7.	Short the LOW and COM terminals on the control board. Does the AC line voltage between the HTR and L2 terminals now read 120 vac (line voltage)?	No	Replace water level control P/N <a href="#">23198</a>
		Yes	Go to Step #9
8.	Disconnect the wires from the HI and COM terminals on the control board and short the HI & COM terminals together. Measure the AC line voltage between the WF and L2 terminals. Is the voltage 0 vac?	No	Replace water level control P/N <a href="#">23198</a>

STEP	TEST	RESULT	REMEDY
9.	Remove the short from the HI and COM terminals on the control board. Does the AC line voltage between WF and L2 stay at 0 vac for about five seconds, then jump to 120 vac?	Yes	Reconnect HI & COM wires and go to Step #10
		No	Replace water level control P/N <a href="#">23198</a>
10.	Drain all water form the generator. Disconnect the wires from the ID, HI, & COM terminals at the control board. Connect an Ohmmeter across the LO and COM wires leading to the generator. Does the Ohmmeter read greater than 100,000 ohms?	Yes	Go to Step #12 No Go to Step #11
		Yes	Go to Step #12
11.	Disconnect the LO wire at the water sensing probe on the generator. Does the Ohmmeter connected in the previous step now read greater than 100,000 ohms?	No	Replace probe wiring
12.	Reconnect the ohmmeter across each end of the disconnected LO wire. Does the ohmmeter read less than 10 ohms?	Yes	Go to Step #13 No Replace wire
		Yes	Go to Step #15
13.	Connect an ohmmeter across the HI and COM wires leading to the generator. Does the ohmmeter read greater than 100,000 ohms?	Yes	Go to Step #15
14.	Disconnect the HI wire at the water sensing probe on the generator. Does the ohmmeter connected in the previous step now read greater than 100,000 ohms?	No	Go to Step #14
		Yes	Replace probe wiring
15.	Reconnect the ohmmeter across each end of the disconnected HI wire. Does the ohmmeter read less than 10 ohms?	No	Go to Step #16
		Yes	Go to Step #16
		No	Replace probe wiring

STEP	TEST	RESULT	REMEDY
16.	Reconnect one lead of the ohmmeter to the COM wire at the control board and connect the other ohmmeter lead to generator ground. Does the ohmmeter read less than 10 ohms?	Yes	Reconnect HI, LOW & COM wires at control board only. Go to Step =17.
		No	Replace probe wiring
		Yes	Go to Step #18
17.	Reconnect the ohmmeter across the LOW terminal at the sensing probe & generator ground. Does the ohmmeter read greater than 100,000 ohms?	No	Replace probe assembly
		Yes	Go to Step #19
		No	Replace probe assembly
18.	Reconnect the ohmmeter across the HI terminal at the sensing probe & generator ground. Does the ohmmeter read greater than 100,000 ohms?		
19.	Remove probe and check for scale buildup on or across probes. Replace probe assembly as required.		

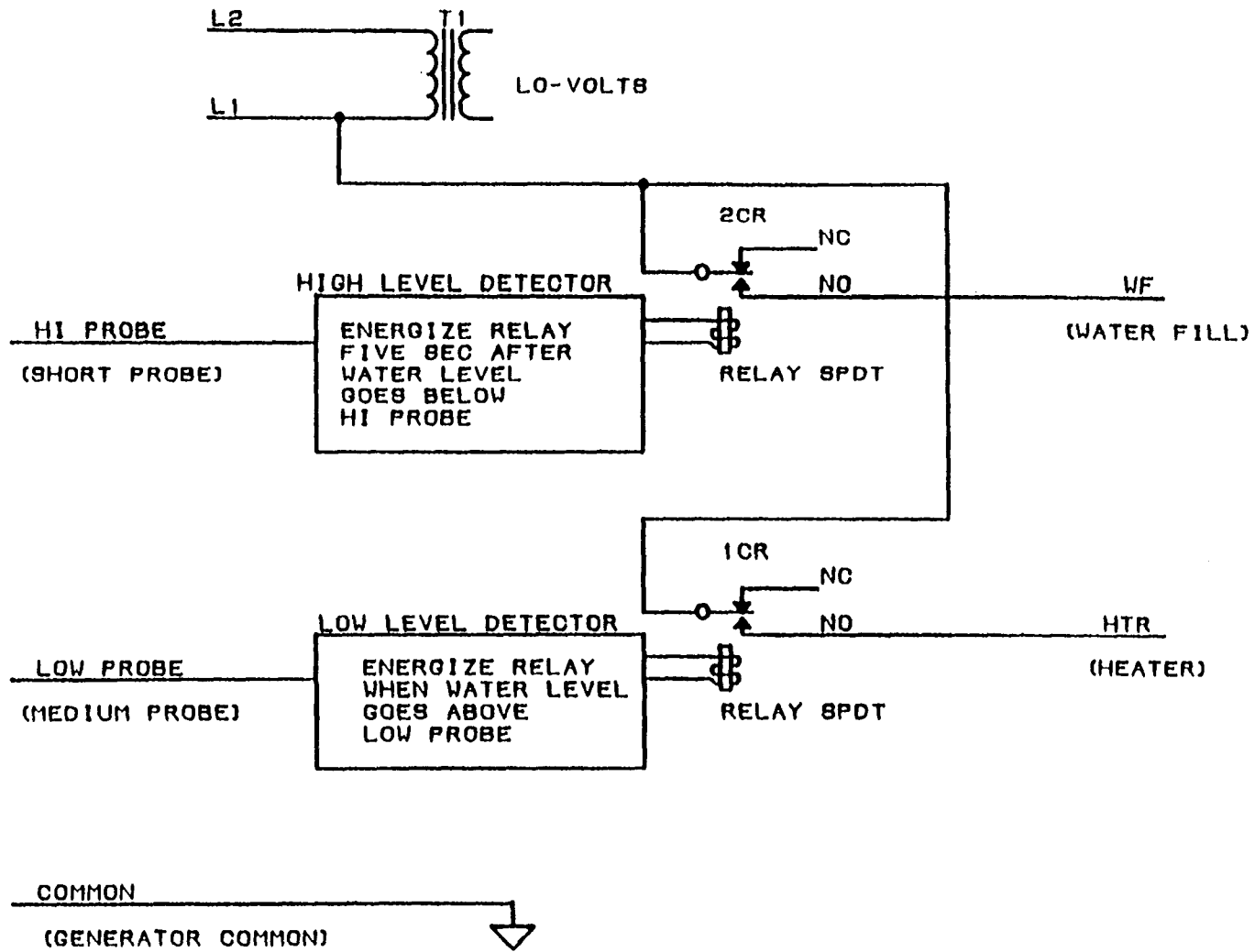

FIGURE 1 TWO-PROBE & COMMON WATER LEVEL CONTROL