

# Cleveland Range

## REPAIR MANUAL

PEM24/36/48-2/3K  
PGM160/200/250/300-2/3K  
PDL/PDM/PDP-2/3K

***Model No. PSM-2/3K***

UNITED STATES  
1333 East 179th St.  
Cleveland, Ohio 44110  
Phone: (216) 481-4900 • FAX: (216) 481-37S2

CANADA  
Garland Commercial Ranges • 1777 Kamato Rd.  
Mississauga, Ontario CN L4W 1X4  
Phone: (416) 624-0260 • FAX: (416) 624-0623

PS-02

# Installation Instructions For Steam Generators, Steamers, Steamer/Kettles: Gas — Electric — Steam Coil

## Installation Instructions For AS Models

- 1) These instructions must be retained By the owner / user for future reference. For installation only in noncombustible locations. Gas units are only to be installed in areas that have provisions for adequate air supply
- 2) Position: For proper operation and drainage, steam generator must be level. It must be set near a floor drain. Attach 1 1/2" piping to a drain connections to carry exhaust steam away from the cabinet. Ends of drain lines must vent to atmosphere to avoid back pressure. Allow a MINIMUM of 6" clearance to the rear and sides of the equipment. The surrounding area must be free and clear of combustibles.
- 3) install in accordance with local codes and/or the National Electric Code ANSI/NFPA No. 70-1984. installation in Canada shall be in accordance with the Canadian Electric Code CSA Standard C22-1. A unit that is connected to electricity must be grounded. A wiring diagram is provided inside the relay box.
- 4) Connect supply lines for 140 — 160° hot water, and cold water, to the unit. Water pressure must be maintained between 35 and 60 PSI. Locations and pressure data are shown on the connection drawing. Long hot water lines should be at least 1/2" IPS. Flush water supply lines thoroughly before connecting. Use water which is low in total solids content and low in gas content. to prevent internal scaling, pitting and corrosion of the steam generator and carry-over of minerals into the steam. Water which is fit to drink can still contain highly detrimental impurities. Refer Water Quality Requirements page.
- 5) Turn on water supply to steam generator. Water valve is inside of base.
- 6) Connect fuel supply

---

### FOR YOUR SAFETY

**Do not store or use gasoline or other flammable vapors and liquids in the vicinity of this or any other appliance.**

#### For Steam Coil Steam Generators—

— Connect steam supply Location is shown on the connection drawing. Incoming steam pressure must be regulated between 35 and 45 psi (30 —45 psi for pressure steamers), Install a strainer ahead of the regulating valve. Flush line thoroughly before connecting.

- Connect the outlet end of the steam coil to an inverted bucket trap. Fill trap with water before installing.
- Connect electricity if unit is equipped with electrical controls. Permanent 115V connection is required. Junction box location is shown on the connection drawing. Unit must be electrically grounded by the installer. For

#### Gas Fired Generators-

— Post in a prominent location, instructions to be followed in the event the user smells gas This information shall be obtained by consulting the local gas supplier.

— Connect gas: Location and pressure data are shown on the connection drawing, installation shall be in accordance with local codes, or in the absence of local codes, with the National Fuel Gas Code ANSI Z223-1 —1984 Installation in Canada shall be in accordance with Installation Codes for Gas Burning Appliances and Equipment B149.1 and B149.2 Use a gas pipe joint compound which is resistant to LP gas. Test all pipe joints for leaks with soap and water solution. Allow 12 inch clearance on right side of all Gas Fired Steam Generator models for servicing gas burners and for proper operation. 12" clearance also provides adequate air openings into the combustion chamber. Never obstruct the flow of combustion and ventilation air. The appliance and its individual shutoff valve must be disconnected from the gas supply piping system during any pressure testing of that system at test pressures in excess of 1/2 psig (3.45 kPa). The appliance must be isolated from the gas supply piping system by closing its individual manual shutoff valve during any pressure testing of the gas supply piping system at test pressure equal to or less than 1/2 psig (3.45 kPa).

- Connect electricity if unit is equipped with electrical controls. Permanent 115V connection is required.

Junction box location is shown on the connection drawing. Unit must be electrically grounded by the installer.

— Lighting and Shutdown Instructions: Rip electrical switch on Open water valve. Open gas valve. Slightly depress and turn control knob to "off" for 5 minutes before lighting gas. Turn control knob to "pilot" depress it completely and light pilot burner. Continue to hold knob in for about 60 seconds, then release. Pilot burner is lighted through hole in panel at bottom of steam generator. Never leave panel off. as this will damage controls. Turn control knob to "on". Depress electrical "reset" switch for main burner ignition. Burners will not light without water in the steam generator. For main burner off. with pilot on, turn control knob to "pilot"- For main and pilot burner off slightly depress and turn control knob to "off" Flip electrical switch off. For Electrical Steam Generators

— Connect electric power Location is shown on the connection drawing. Provide connection as required by your unit Electric supply must match power requirements specified on data plate attached to base. Wiring must be adequate to carry required current at rated voltage. A separate fused disconnect must be supplied and installed. Unit must be electrically grounded by the installer.

CLEVELAND RANGE CO\_ 1333 EAST 179th ST., CLEVELAND, OHIO 44110 LITHO IN U.S.A-

Manufacturer reserves right of design improvement or modification, as warranted.

- 7) Turn on electricity at control circuit switch on steamer console. A red light glows when electricity is on. If water level is correct steam generator will operate by pressing the "reset" button. Heaters will not work without water in the steam generator. This manual reset button must be pressed to start up the generator initially, and to restart the steam generator after every shut off, or power interruption. No attempt should be made to operate the equipment during a power failure.
- 8) Check to make sure that the water in the sight gauge glass automatically stays at about 2/3 full when the unit is started up.
- 9) When installation is complete and free of leaks, refer to Operating Procedures sheet.

### Instructions For Steam Generator Care

Protect your steam generator, prolong its life and preserve its performance by giving it the required daily attention, on a regular schedule. Follow servicing instructions for your steam generator which are printed on Data Sheet 260-LC in your Owner's Manual, and also on an adhesive label attached to the unit. To obtain an additional data sheet or label carrying servicing instructions, write to the Cleveland Range Company.

### WARNING

**No work should be done on the steam generator while it is pressurized or hot. Service of the steam generator should only be performed by a trained and experienced service technician, thoroughly familiar with servicing steam generators. When maintenance or repairs are required, contact a local food service equipment service agency, or call the factory, or a factory representative for the name and address of one in your area.**

### Steam Generator (Boiler) Safety

Rigid regulations govern the design and construction of a boiler. However, the responsibility for the safe and efficient operation of a boiler shifts to the owner/user after the boiler leaves the factory.

A sound boiler if improperly installed, or if improperly maintained, or if improperly repaired, will create a dangerous situation and may cause injury to personnel.

Most states, provinces and some cities have a boiler safety law. Many underwriters require that their clients' boilers comply with these boiler safety laws. These safety laws call for action by the boiler manufacturer and action by the boiler owner/user.

As a manufacturer, The Cleveland Range Company delivers steam generators built to the ASME Boiler Code, Section IV, which have been inspected by a National Board Inspector. Also, each Cleveland Range Company boiler is built to comply with the boiler safety law of the state to which it is sent.

#### Safe and Efficient Boiler Operation Depends on Proper Installation

Install the boiler in compliance with following regulations, where they apply:

- The National Fuel Gas Code, ANSI Z223.1-1984
- The local and municipal building code (plumbing and electrical)
- Installation Codes for Gas Burning Appliances and Equipment B149.1 and B149.2
- The state and city boiler laws
- The Cleveland Range Company Installation instructions
- The recommendations of the owner/user's under-writers
- The National Electrical Code ANSI/NFPA No.70-1984

The water for the boiler should be analyzed by a reputable boiler water specialist to see if the quality will permit safe and efficient boiler operation. Water treatment is becoming increasingly necessary because the quality of water sources is deteriorating, although treatment will not be required in every case. A boiler will not operate properly for very long if the water causes boiler corrosion or scale. Even water which is safe to drink may be detrimental to a boiler. Refer to Water quality Requirements page for details.

#### Safety Requires Periodic Inspection and Maintenance

Any leaks around the boiler's hand hole must be quickly stopped. Small leaks, if unchecked, cause corrosion and pitting on the boiler face around the hand hole gasket, making it unsealable.

Application of undue stress on the parts that are used to seal the boiler's hand hole opening, in an attempt to seal an unsealable opening, by sledging the handle of the wrench, by increasing the leverage of the wrench a length of pipe, or by other means, is dangerous because it may result in the breakage of parts, or injury. No attempts should be made to tighten up the nut on the retaining stud beyond the recommended 15 foot pounds of torque.

When a repair affecting the safety of the boiler is necessary, call a National Board Inspector for consultation and advice as to the best method of making the repair, so that the completed work will get his approval. Repairs to the boiler must conform to the applicable provisions in the ASME Code or the National Board Rules for Repairs.

A boiler will last many years before it has to be retired from service. Periodic inspection will reveal the approaching retirement time. It is better to schedule a convenient replacement time than to wait for the boiler to fail. When a boiler older than 10 years is replaced, the entire steam generator base assembly should be replaced for a number of reasons:

- Replacement parts become increasingly difficult to obtain for older controls.
- Dependable performance of the new controls can be assured for a longer time.
- The new steam generator, including controls, will comply with the latest industry and safety standards.

**CLEVELAND RANGE CO., 1333 EAST 179th ST., CLEVELAND, OHIO 44110**

## PRESSURE STEAMER OPERATING INSTRUCTIONS

NOTE: These instructions pertain to steamers equipped with self-contained steam generators (boilers). For steamers direct-connected to a remote (in-house) steam source, disregard those instructions which are directly and solely related to the self-contained steam generator. These instructions are to be retained by the owner/user for future reference.

1A Open the cabinet base door and close the drain valve if it is open.

B Make sure the hot and cold water supply valves are open

C For steamers equipped with a gas-fired steam generator (boiler) follow the lighting instructions noted on the instruction label displayed on the unit before continuing to instruction in item 2.

- 2 Flip the toggle switch on front of the cabinet console to "ON" The red console light should then glow and the boiler will automatically begin filling with water (if it is not already full).
- 3 After approximately five minutes (after water appears in the sight gauge), depress the "START" reset button on the console. This will energize the electric heater elements or ignite the gas burners. This cannot be accomplished until the boiler is full of water.
- 4 In approximately 15 minutes you will notice the console's steam pressure gauge register 5 pounds. (10 pounds if the boiler is also supplying steam to a kettle- The upper pressure gauge will register 5 pounds.) You can now preheat the cooking compartments.
- 5 Compartments should be preheated before use and should be kept hot between loads. If a Kettle and steamer are to be used at the same time, always heat the kettle unit first. When kettle contents begin to simmer, preheat the steamer compartments- When pressure on the boiler gauge returns to 10 pounds, cooking may begin in the steamer
- 6 Close and latch door securely. Turn bar handle clockwise until the door gasket just touches the compartment face
- 7 Start steam supply by pulling steam valve handle out. If fitted with automatic timer, set timer for 5 minutes. At the start, compartment thermostatic traps should release air and wet steam for about two minutes, then shut off.
- 8 Seal compartment door by turning bar handle clockwise just until steam leakage stops. DO NOT OVERTIGHTEN.
- 9 At the completion of the 5 minute preheating cycle, push steam valve slowly in, to avoid boilovers. This shuts off the steam supply and also depressurizes and drains the compartment. If fitted with an automatic timer, the steam shuts off automatically and a bell rings when the timer reaches zero. Setting the timer to "Off" stops the bell.
- 10 To open compartment door, turn bar handle counter-clockwise and delatch.
- 11 Cooking can now begin by following the above operating steps #6 through #10, but setting the timer for the required cooking time- At the end of a cooking cycle 40 minutes long or longer, or when defrosting frozen foods, wait at least two minutes for the compartments) to depressurize and drain before opening the compartment door.

**CAUTION: After each cooking cycle, ensure that all water is draining, and not accumulating in the compartment. Should a drain become obstructed, it must be cleared before attempting to cook in that compartment.**

12. At the end of each day's operation, flip the console toggle switch to the "Blowdown" position, open the door in the cabinet base and open the boiler drain valve, (red handle). This "Blowdown" drains the boiler and helps to keep it clean. When the boiler is empty, flip the console toggle switch to the "OFF" position and close the boiler drain valve
13. It is recommended that the boiler be refilled with water after the "Blowdown" is performed. This can be accomplished by flipping the toggle switch to the "ON" position for a period of five minutes and then returning the switch to the "OFF" position.

### TO PROLONG LIFE AND MINIMIZE SERVICE REQUIREMENTS

1. Blow down the steam generator daily.
2. A periodic boiler inspection must be performed by a qualified serviceman to prolong its life and to minimize service calls
3. At the end of each day's operation, wash the pan slides, drain screen covers, door gaskets, and compartment interiors with mild detergent and warm water- Thoroughly rinse with clean water. Rinse water should drain freely through the compartment drain openings. If it does not, the drain must be cleaned before using the steamer.
4. Once a week, flush each compartment drain with a food service equipment drain cleaner and a deliming solution
- 5 Once every three months, shut off the water supply (hot and cold), and clean the water line strainers.
6. Compartment thermostatic traps can be disassembled and cleaned, by hand or in a mechanical dishwasher. This procedure is recommended if the traps act sluggishly, as they may if contaminated by grease or other film. If cleaning fails to restore the trap's proper functioning, replace the trap. For more detailed thermostatic trap servicing instructions., refer to Data Sheet 260-LH.

**CLEVELAND RANGE, INC., 1333 EAST 179th ST., CLEVELAND, OHIO 44110**

Manufacturer reserves right of design improvement or modification, as warranted.

7. Shelves, drain screens, and pan slides are stainless steel, and can be washed safely in a mechanical dishwasher.
8. Exterior Care: Allow steamer 10 minutes cool before washing. Use the same cleaners and cleaning procedures as for other kitchen surfaces of stainless steel and aluminum. Mild soapy water, with a clear water rinse, is recommended. Do not allow water to run into electrical controls- Always turn off equipment power before using water to wash equipment.
9. Compartment Door Care:
  - a. When doors are closed for preheating or cooking, turn bar handle just enough to stop steam leakage. Overtightening shortens gasket life.
  - b. When doors are open or unlatched. Do not turn bar handle.
  - c. Always leave compartment doors ajar when not in use, to extend gasket life and to prevent gaskets from adhering to the steamer. Unnecessary compression of a gasket shortens its life.
  - d. Keep bar handle screws clean. Lubricate frequently but not excessively.
  - e. Door gaskets provide many months of service when care is taken to operate doors properly. When a gasket finally wears and does not maintain an effective seal, it must be replaced. Door gaskets can be replaced easily without special tools or cement, and the steamer may be used immediately afterwards- Remove the old gasket and clean the channel. being careful not to damage the channel. The new gasket can then be pressed into place. Insert the gasket in the corners of the channel first, adjusting the slack evenly between the corners- Then work from the corners to the center. Ridges hold the gasket firmly. The gasket is designed to be oversized, so once it is compressed into the door's channel, it remains firmly in place.

#### PRESSURE STEAMER SAFETY

**FOR YOUR SAFETY**  
 Do not store or use gasoline or other flammable vapors  
 and liquids in the vicinity of this or any other appliance.

Being the owner of a steamer carries with it the responsibility for keeping it in as safe a condition as when it was shipped from the factory. Safe steamer operation dictates that every pressure steamer must have the following safety inspection at least every 12 months.

#### 1. Steam Valve Linkages

Have a qualified serviceman examine the steam valve linkages which are attached to the inlet and exhaust valves' operating handles on the left side of the steamer. This pivoted linkage, which is attached to both the steam inlet valve and the steam exhaust valve, must prevent the door's latch from disengaging from its catch when the steamer compartment is pressurized. It is important that the linkage operates as described so that the steamer door cannot be opened when the compartment is pressurized.

It is also important that when the steam valve is closed, the exhaust valve should open. The proper operation of the steam inlet valve and the steam exhaust valve should be confirmed and observed while the steam is on.

2. **Pressure Gauge** Check each pressure gauge. Gauge pointer must return to zero when the steam generator is shut down. Look for signs of water, rust, corrosion, or scale, inside the pressure gauge. A faulty pressure gauge should be replaced immediately.

#### a Door Gaskets

Inspect and replace compartment door gaskets once a year, or sooner if they are torn or hardened. The use of a hardened gasket produces undue stress in the parts which comprise the door enclosure and may result in breakage and injury.

#### 4. Compartment Thermostatic Trap

Observe compartment thermostatic traps for proper operation. A good compartment trap, at start-up of a cooking cycle, is normally open and releases air and wet steam briskly for a few minutes. then holds steam within compartment. If brisk venting doesn't begin immediately at start-up, or if brisk venting continues without stopping, and the compartment trap is over a year old, it should be cleaned, or a new one installed- Refer to data sheet 260-LH for details

#### 5 Compartment Steam Exhaust Valves and Drain Valves

Make sure that the compartment steam exhaust valves, and the drain lines attached to them, are free of food buildup internally and are venting freely to the atmosphere. If drain lines from other steam-consuming equipment have been connected to the drain line from the steamer, the other drain lines should be disconnected. Never operate a compartment without the drain screen cover in place.

6. Refer to separate data sheets for steam generator operation, maintenance, and safety procedures.

#### WARNING

**Service of steam cooking equipment should only be performed by a trained and experienced service technician, thoroughly familiar with servicing steam equipment. No work should be performed on the steamer while it is pressurized or hot. Be sure all energy sources are shut off before the start of any work. When maintenance or repairs are required, contact a local food service equipment service agency, or call the factory. or a factory representative, for the name and address of one in your area.**

## PRESSURE STEAMERS: THERMOSTATIC TRAP AND COMPARTMENT DOOR GASKET REPLACEMENT

The thermostatic trap and door gasket on your steamer stop the escape of steam from the compartment during operation. Steam leakage from either source will cause loss of pressure, which will result in longer cooking time, wasted steam and excessive condensation.

To keep your steamer operating at peak efficiency, thermostatic traps and compartment door gaskets require periodic replacement. Frequency of replacement varies from one piece of equipment to another depending on the amount of usage, and frequency and quality of maintenance.

### COMPARTMENT THERMOSTATIC TRAP

A normal thermostatic trap at startup releases air and wet steam briskly for the first few minutes, then holds steam within the compartment. During cooking, the trap will also release accumulated condensate and a small amount of air.

If brisk venting doesn't begin immediately at startup or if brisk venting continues for much longer than two minutes, and the compartment trap is over a year old, it should be cleaned, or removed and a new one installed.

A compartment trap less than a year old may act sluggishly only because it is contaminated by grease and other film.

To remove a thermostatic trap, unscrew the union nut as shown on the sketch.

To clean the trap, unscrew the threaded diaphragm cover from the body and wash the entire assembly. A more thorough cleaning can be accomplished by removing and disassembling the trap, and washing the entire assembly in a mechanical dishwasher.

With proper tools, the threaded diaphragm cover can be unscrewed from the body, and the thermostatic diaphragm can be unscrewed from the diaphragm cover, if the trap does not work properly after thorough cleaning, install a new one.

If the steamer is used heavily for cooking foods containing large amounts of fat or starch, periodic cleaning is recommended as a routine procedure.

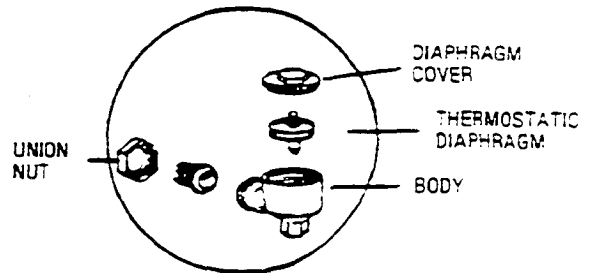

### COMPARTMENT DOOR GASKET REPLACEMENT

Replace the gaskets on compartment doors once a year, or sooner if they are torn or hardened.

Door gaskets can be replaced easily without special tools or cement, and the steamer may be used immediately afterwards.

Remove the old gasket and clean the channel, being careful not to damage the channel. The new gasket can then be pressed into place. Insert the gasket in the corners of the channel first, adjusting the slack evenly between the corners. Then work from the corners to the center. Ridges hold the gasket firmly. The gasket is designed to be oversize, so once it is compressed into the door's channel, it remains firmly in place.

### WARNING

**Service of steam cooking equipment should only be performed by a trained and experienced service technician, thoroughly familiar with servicing steam equipment. No work should be performed on the steamer while it is pressurized or hot. Be sure all energy sources are shut off before the start of any work. When maintenance or repairs are required, contact a local food service equipment service agency, or call the factory, or a factory representative, for the name and address of one in your area.**

## MODELS B, C, F, K PRESSURE STEAMERS DOOR AND DOOR ARM ASSEMBLY

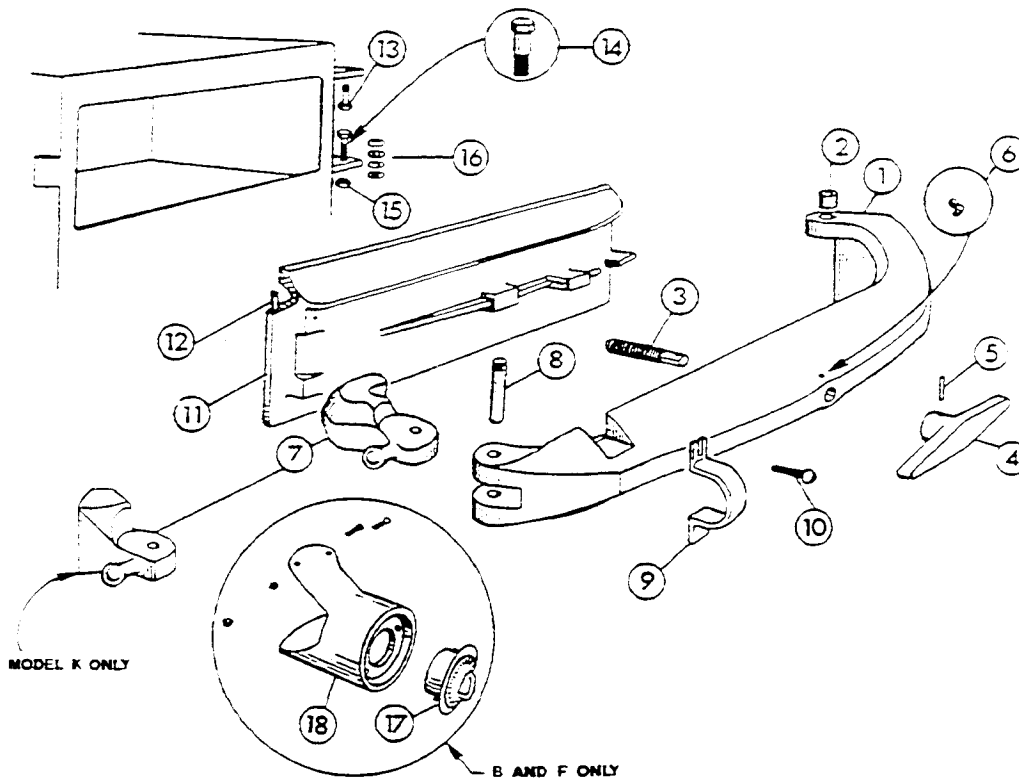

REFERENCE NUMBER	PART NUMBER	DESCRIPTION
1	25303	Door Ann With Bushings — Model B & C, Polished
	25304	Door Arm With Bushings — Model F & K, Polished
2	02568	Door Arm Hinge Bushing (2 Required)
3	41370	Standard Door Ann Screw With Ball (1" x 8 thread)
	41371	Oversize Door Ann Screw With Ball 1 3/32" x 8 thread)
4	081001	Screw Handle Bar, Polished
5	16305	Pin
6	15250	Oil Cup
7	122011	Door Ann Latch — Model B, C, & F Chrome Plated
	122021	Door Ann Latch — Model K Chrome Plated
8	101018	Door Arm Latch Pin — Model B, C, F, & K Brass
	163101	Door Ann Latch Pin — Model B, C, F, & K Chrome Plated
9	081031	Door Retainer — Model B, C, F, & K Chrome Plated
10	19291	Screw
11	041631	Door, Model B Polished
	04164	Door, Model C Polished
	04165	Door, Model F & K Polished
12	07132	Door Gasket — Rubber, Model B
	07134	Door Gasket — Rubber, Model C, F, K
13	023001	Door Arm Hinge Post Bolt (Upper) — Concentric Type —
14	023061	Door Arm Hinge Post Bolt (Lower) — Eccentric Type —
15	14643	Nut, For Lower Hinge Post Bolt
16	23181	Shim Washer
17	40547	60 Minute Bell Timer Assembly
18	08601	Timer Housing — Model B & C Polished (Not Available)
	08606	Timer Housing — Model F Polished (Not Available)

**CLEVELAND RANGE CO., 1333 EAST 179th ST., CLEVELAND, OHIO 44110**

Manufacturer reserves right of design improvement or modification, as warranted.

## MODEL J DOOR AND DOOR ARM ASSEMBLY

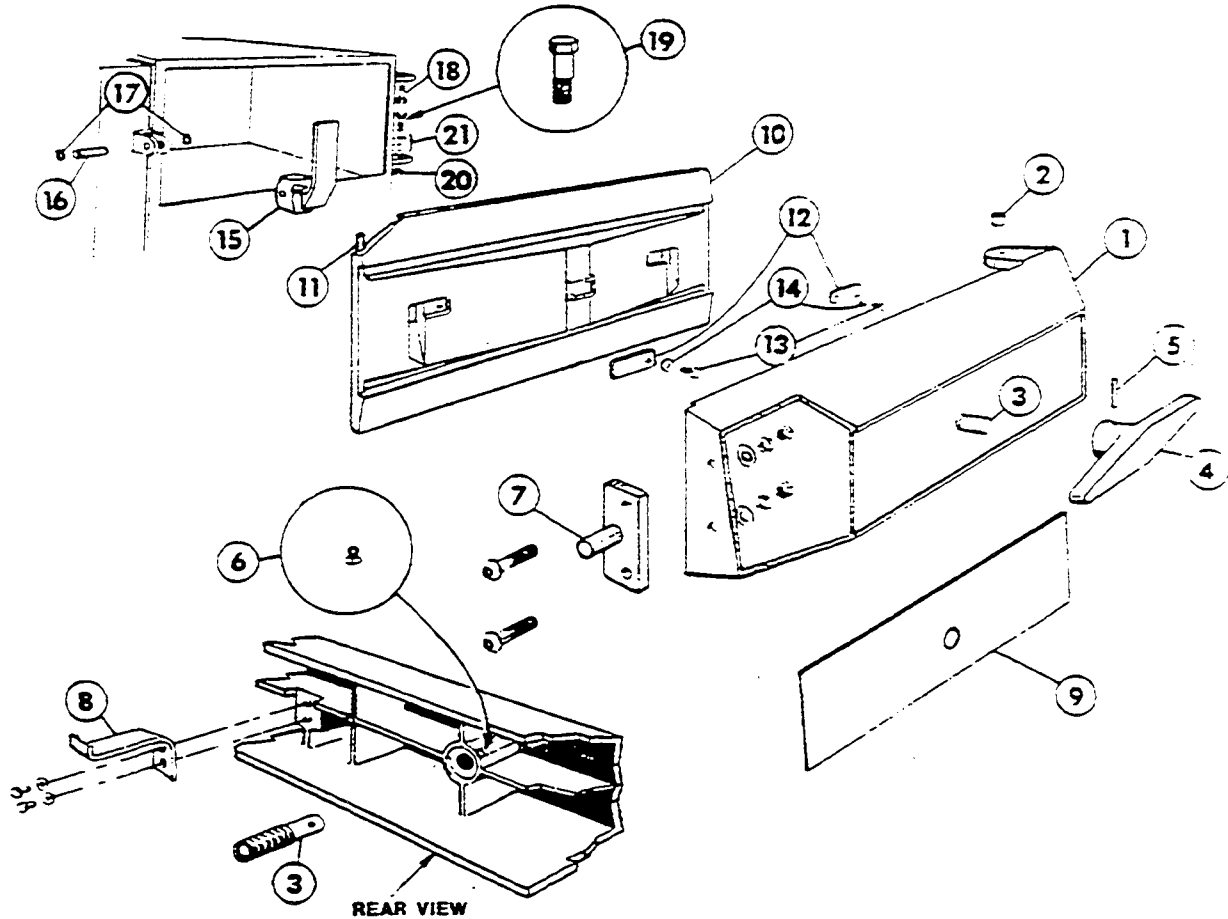

REFERENCE NUMBER	PART NUMBER	DESCRIPTION
1	253021	Door Arm W/Bushings. Polished
2	02568	Door Arm Hinge Bushing (2 Required)
3	41370	Standard Door Arm Screw With Ball (1" x 8 thread)
	41371	Oversize Door Arm Screw With Ball (1 3/32" x 8 thread)
4	081001	Screw Handle Bar, Polished
5	16305	Pin
6	15250	Oil Cup
7	41360	Striker Plate and Pin
8	43723	Door Hanger w/Screws and Washers (2 Required)
9	53035	Door Arm Insert, Stainless
10	04162	Polished Aluminum Door, Less Gasket
11	07136	Door Gasket — Rubber
12	68140	Retainer, Yoke Hanger (2 Required)
13	19228	Screw
14	23182	Washer
15	122001	Door Arm Latch, Chrome Plated
16	163141	Door Arm Latch Pin, Chrome Plated
17	18306	Retainer Clip, (2 Required)
18	023001	Door Arm Hinge Post Bolt (Upper) — Concentric Type —
19	023061	Door Arm Hinge Post Bolt (Lower) — Eccentric Type —
20	14643	Nut, For Lower Hinge Post Bolt
21	23181	Shim Washers

**CLEVELAND RANGE CO., 1333 EAST 179th ST., CLEVELAND, OHIO 44110**  
 Manufacturer reserves right of design improvement or modification, as warranted.



MECHANICAL COMPARTMENT CONTROLS  
MODEL K PRESSURE STEAMERS-  
DEC. 1977 THRU PRESENT

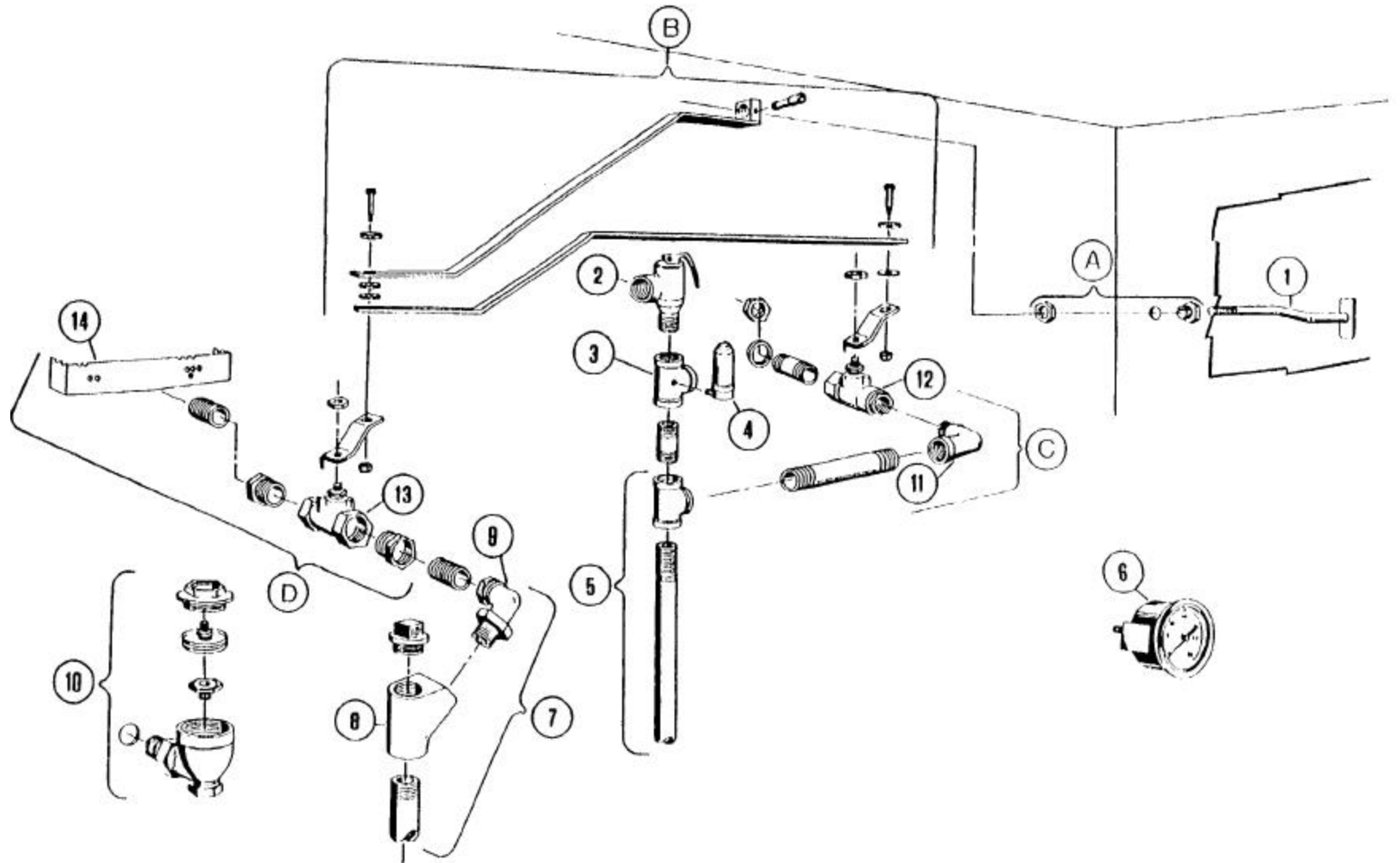

REPLACEMENT PARTS SHOWN IN RED ARE USED TO  
CONVERT OLDER STEAMERS, BUILT BEFORE DEC. 1977,  
WHICH CONTAINED GATE VALVES (GROUPS A, B, C AND D)

## MECHANICAL COMPARTMENT CONTROLS MODEL K PRESSURE STEAMERS-DEC. 1977 THRU PRESENT

REFERENCE NUMBER	PART NUMBER	DESCRIPTION
1	40650	Pull Rod Handle
2	22130	Valve, Safely, 8 psi
3	70411	Tee, Special 3/4"
4	22140	Air Vent
5	42270	Inlet Manifold Ass'y.—2-Compl.—Mech. "K", Less Valves
	42279	Inlet Manifold Ass'y.—3-Compl.—Mech. "K", Less Valves
6	07173	Gauge, Pressure, Rear Mount, 0 30 psi, 2 1/2"
	07168	Gauge, Pressure, Rear Mount, 0-30 psi, 2"
7	42290	Exhaust Manifold Ass'y.—2-Compl., Model "K", Less Valves
	42291	Exhaust Manifold Ass'y.—3-Compl., Model "K", Less Valves
8	02146	"Y" Bend
9	05263	Ell, 3/4" Radiator Union
10	20551	Thermostatic Trap—Plain End
11	05252	Ell, 1/2" Street
12	22212	Valve, 1/2 Ball, Inlet Steam
13	22213	Valve, 1" Bullerly, Exhaust Steam
14	41100	Drain Cover Screen (Before 7/17/85)
	69333	Drain Cover Screen (After 7/18/85)
A	43765	Bushing Ass'y.
B	40677	Linkage Ass'y., Model "K"
C	42670	Conversion Kit, Inlet Valve—"K" Mech., Includes: 1/2" Inlet Steam Valve, 1/2" Street Elbow, 1/2 x 4" Nipple, 1/2" x 2 1/4" Special Nipple, (2) Locknuts, (2) Sealing Washers
D	40710	Conversion Kit, Exhaust Valve, Includes: 1" Exhaust Steam Valve, (2) 1" x 3/4" Bushings, 3/4" Close Nipple, Drain Cover Screen

**NOTE: FOR SAFETY PURPOSES, DRAIN SCREEN COVER MUST BE IN PLACE WHEN OPERATING EQUIPMENT.**

**AUTOMATIC COMPARTMENT CONTROLS  
MODEL K PRESSURE STEAMERS-  
DEC. 1977 THRU PRESENT**

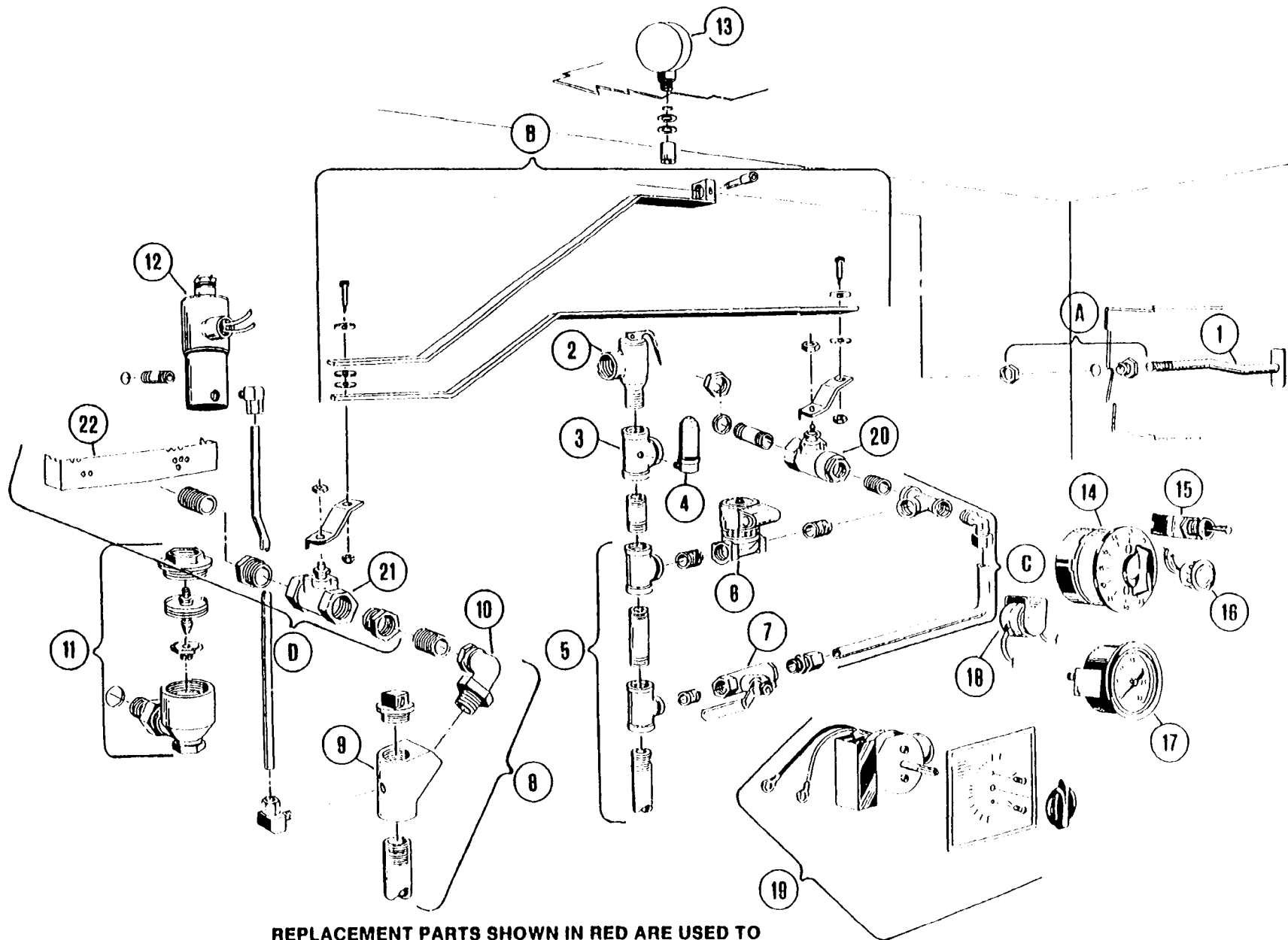

**REPLACEMENT PARTS SHOWN IN RED ARE USED TO  
CONVERT OLDER STEAMERS, BUILT BEFORE DEC. 1977,  
WHICH CONTAINED GATE VALVES. (GROUPS A, B, C, AND D.)**

**AUTOMATIC COMPARTMENT CONTROLS  
MODEL K PRESSURE STEAMERS — DEC. 1977 THROUGH PRESENT**

REFERENCE NUMBER	PART NUMBER	DESCRIPTION
1	40650	Pull Rod Handle
2	22130	Valve, Safety, 8 PSI
3	70411	Tee, Special 3/4"
4	22140	Air Vent
5	42298	Inlet Manifold Ass'y.—2-Compl —Auto "K", Less Valves
	42299	Inlet Manifold Ass'y.— 3-Compt.— Auto "K", Less Valves
6	22115	Valve, 1/2" Steam Inlet Solenoid
7	03278	Valve, Steam By-Pass
8	42290	Exhaust Manifold Ass'y.— 2-Compl., Model "K", Less Valves
	42291	Exhaust Manifold Ass'y—3-Compl., Model "K", Less Valves
9	43764	"Y" Bend—with 1/4" Tapped Hole
10	05263	El, 3/4" Radiator Union
11	20551	Thermostatic Trap—Plain End
12	22199	3/4 Solenoid Valve, Auto Exhaust, 115 Volt, For Use With 40518 Timer
	22185	1/4" Solenoid Valve, Auto Exhaust, 115 Volt, For Use With 40540 Timer
13	07172	Gauge, Pressure, Bottom Mount, 0-30 PSI
14	40518	Timer, 60 Min, Mechanical (Mfg. # 70000)
15	19977	Switch-SPST
16	12161	Signal Light, 1"
	12169	Signal Light, 1/2"
17	07173	Pressure Gauge, Rear Mount, 0-30 psi, 2 1/2"
	07168	Pressure Gauge, Rear Mount, 0-30 psi, 2"
18	41350	Buzzer
19	40540	Timer, 105 Min, (Mfg. 601)
20	22212	Valve, 1/2" Ball, Inlet Steam
21	22213	Valve, 1" Butterfly, Exhaust Steam
22	41100	Drain Cover Screen (Before 7/17/85)
	69333	Drain Cover Screen (After 7/18/85)
A	43765	Bushing Ass'y.,
B	40677	Linkage Ass'y., Model "K"
C	40711	Conversion Kit, Inlet Valve-"K" Auto, Includes: 1/2" Inlet Steam Valve, 3/8" Tube Ftng, 3/8"— 90° Tube Ftng., (2) 1/2" Close Nipples, 1/2" x 2 1/4" Special Nipple 1/2 x 3/8" x 1/2 Tee, 3/8" x 6" Tube, (2) Lock-nuts, (2) Sealing Washers.
D	40710	Conversion Kit, Exhaust Valve, Includes: 1" Exhaust Steam Valve, (2) 1" x 3/4" Bushings, 3/4 Close Nipple, Drain Cover Screen.

**NOTE: FOR SAFETY PURPOSES, DRAIN SCREEN COVER MUST BE IN PLACE WHEN OPERATING EQUIPMENT**

## INTERMEDIATE DRAWOUT & LIFTOUT SHELF MODELS B, F, J, AND K PRESSURE STEAMERS

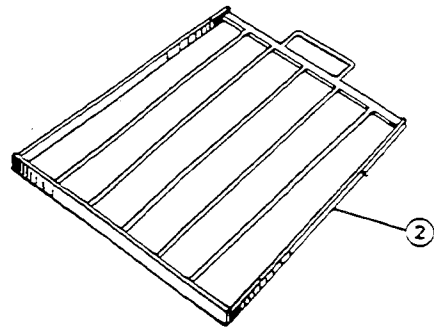
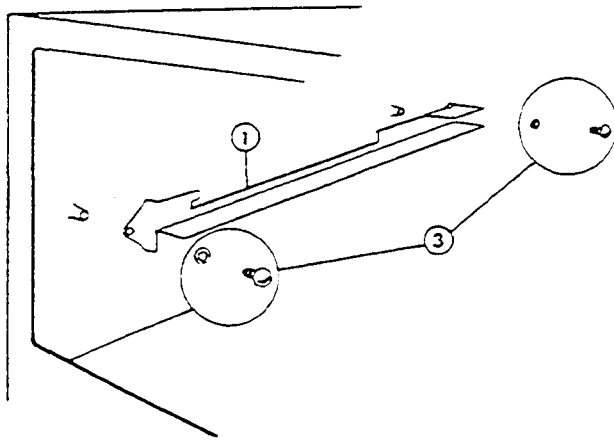
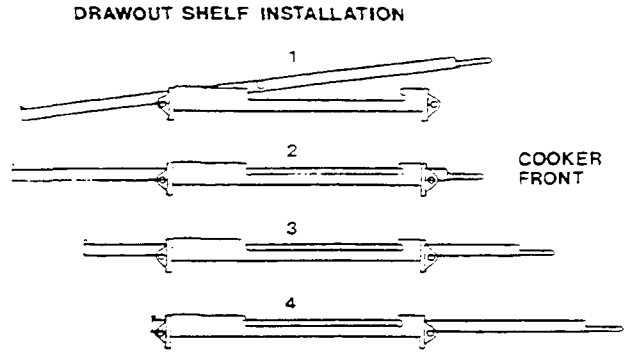
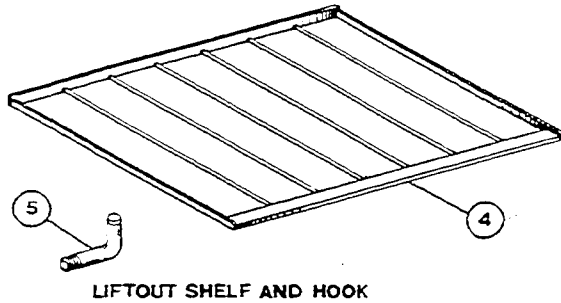

REFERENCE NUMBER	PART NUMBER	DESCRIPTION
1	• 19500	Angle Slide, Draw-Out Shelf, Model B, Right (Not Available)
	• 19502	Angle Slide, Draw-Out Shelf Model B, Left (Not Available)
	*19501	Angle Slide, Draw-Out Shelf, Model F, Right (Not Available)
	•19503	Angle Slide, Draw-Out Shelf, Model F, Left (Not Available)
	2	42183
2	42814	Draw-Out Intermediate Shelf, Model F, J, & K
	3	43737
4	42180	Lift-Out Shelf, Model B
	42181	Lift-Out Shelf, Model F & K
5	08440	Lift-Out Shelf Hook, 4 Required Per Shelf

Substitute: 4 ea. — 08440 Hooks  
1 ea. — 42181 Shelf

CLEVELAND RANGE, INC., 1333 EAST 179th ST., CLEVELAND, OHIO 44110  
Manufacturer reserves right of design improvement or modification, as warranted.

## AUTO SHELF ASSEMBLY MODELS B & F PRESSURE STEAMERS

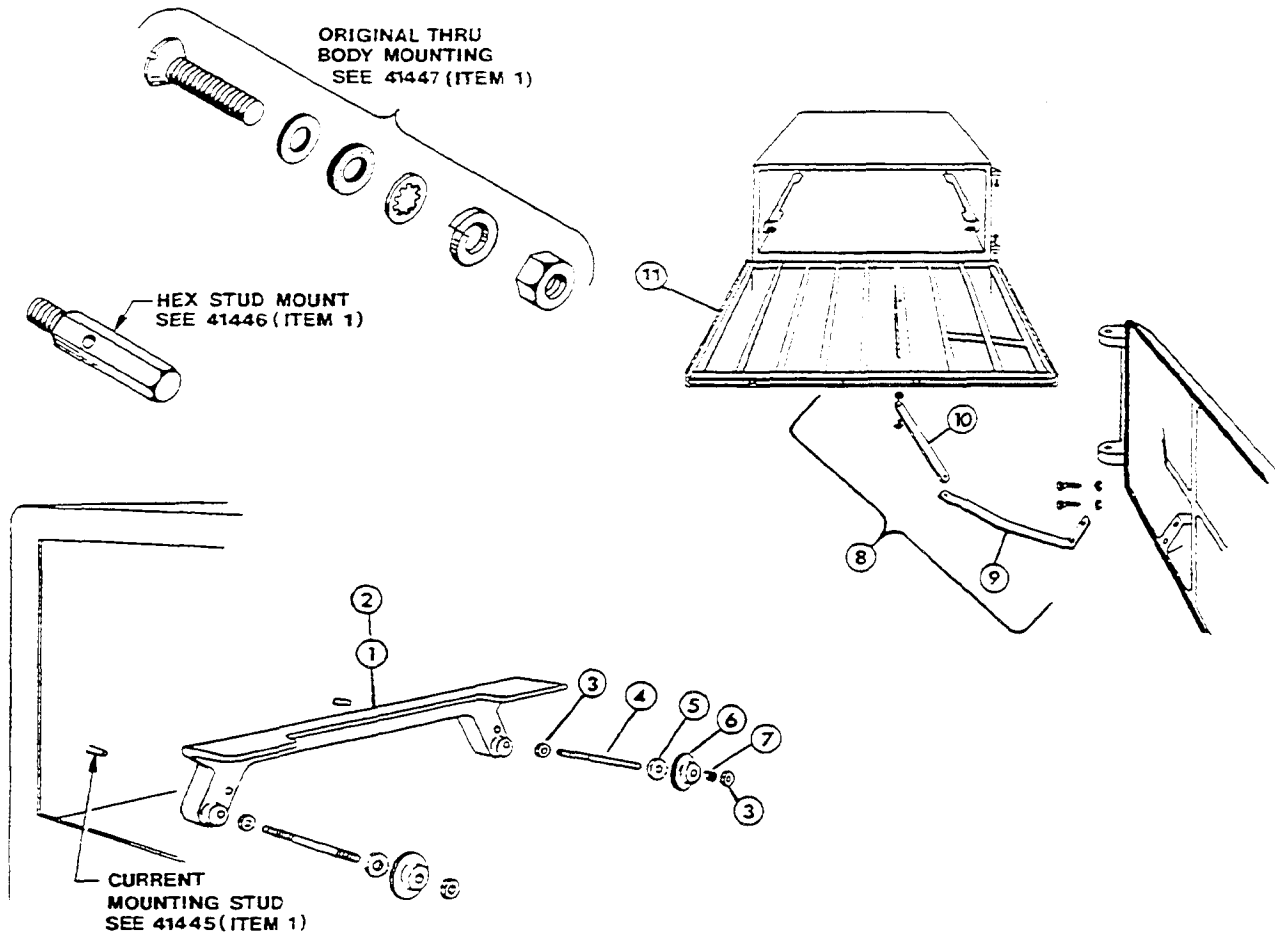

REFERENCE NUMBER	PART NUMBER	DESCRIPTION
1	41445	Angle Slide Ass'y With Rollers, Models B & F, Includes 2 Weld Studs 19915 (Current, Since 1968) (Shown)
	41446	Angle Slide Ass'y With Rollers, Models B & F, Includes 2 Hex Mounting Studs 19924
	41447	Angle Slide Ass'y With Rollers, Models B & F, Includes Original Style Body Mounting Bolt & Washers, etc.
2	01250	Angle Casting, Machined, Welded Stud, Models B & F
	01251	Angle Casting, Machined. Hex Stud, Models B & F
	01252	Angle Casting, Machined. Bolted Stud, Models B & P
3	14629	Lockout
4	19900	Roller Stud
5	23133	Washer
6	18720	Roller
7	19572	Roller Spring
8	43800	Shelf Arm & Connecting Rod Ass'y, Model B
	43801	Shelf Ann & Connecting Rod Ass'y, Model F (Shown)
9	51002	Sliding Shelf Arm, Model B
	51004	Sliding Shelf Arm, Model F (Shown)
	42190	Connecting Rod, Model B
10	42191	Connecting Rod, Model F (Shown)
	42185	Auto Sliding Shelf, Model B
11	42186	Auto Sliding Shelf, Model F (Shown)

# MODELS J AND K PRESSURE STEAMER SLIDE SETS

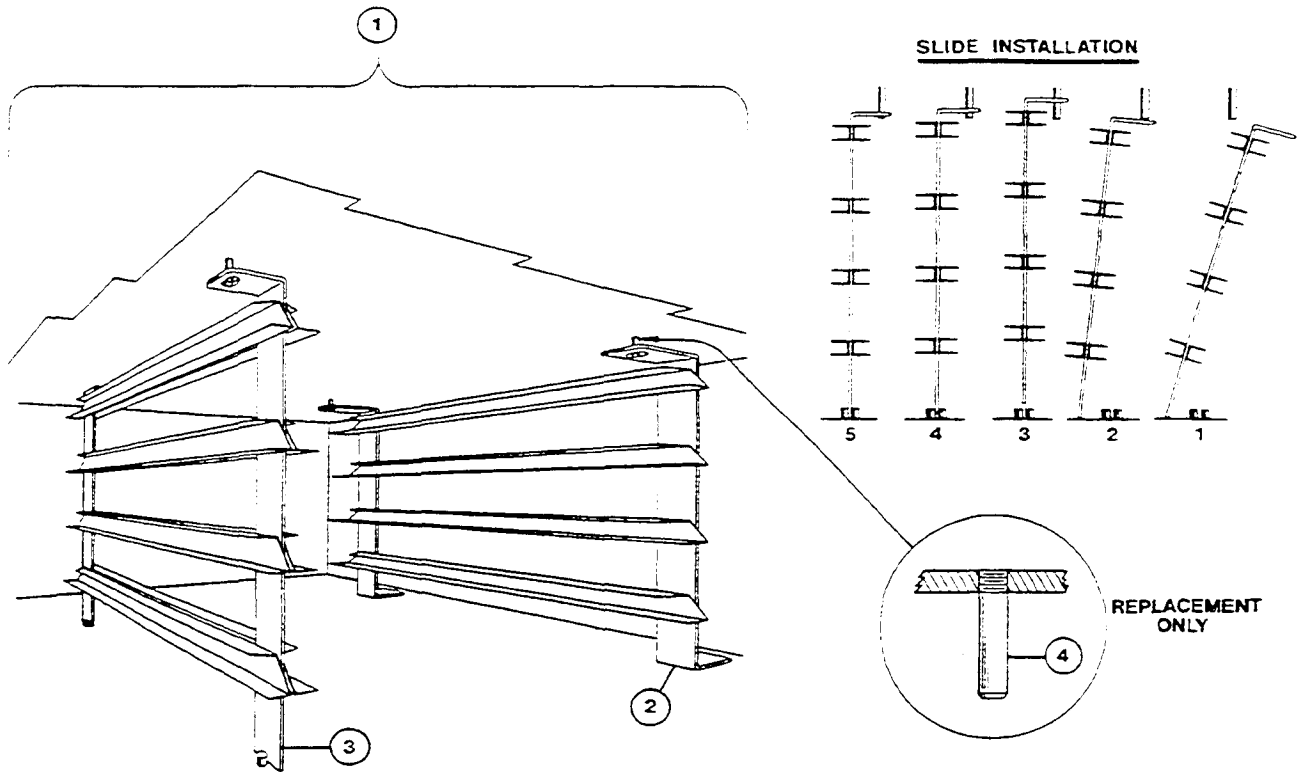

REFERENCE NUMBER	PART NUMBER	DESCRIPTION
1	41440	Pan Support Slide Set, Model J Complete
	41442	Pan Support Slide Set, Model K Complete
2	41430	Right or Left Side Slide Rack, 2 Per Compt Req'd. Model J
	41432	Right or Left Side Slide Rack, 2 Per Compt Req'd. Mode) K
3	41435	Center Slide Rack Model J, 1 Req'd Per Compt
	41437	Center Slide Rack Model K, 1 Req'd Per Compt
4	19909	Replacement Top Studs (Screw-In) J or K (Set of 6)

**CLEVELAND RANGE, INC., 1333 EAST 179th ST., CLEVELAND, OHIO 44110**  
 Manufacturer reserves right of design improvement or modification, as warranted.

---

## START-UP MAINTENANCE PROCEDURES — STEAM GENERATOR

---

**IMPORTANT: These instructions must be followed in order to prevent premature failure of the steam generator**

### START-UP:

- 1) Open the cabinet base door and ~~close~~ the drain valve if it is open (Red Handle lever marked "blowdown")
- 2) Flip the toggle switch on front of the cabinet console to "ON" (up position). The red console light should then glow and water will automatically begin filling the generator.
- 3) When the water level in the sight gauge glass (on the generator) reaches approximately 2/3 full (after approximately five minutes), depress the "ON" reset button on the console. This will energize the electric heater elements or ignite the gas burner. If the sight gauge glass is completely filled, have the generator serviced.
- 4) In approximately ten minutes you will notice the steam pressure gauge, on the console, register the steam pressure contained inside the generator.
- 5) Cooking may now begin. Refer to "Cooking" and "Opening Procedure" data sheets for specific instructions.

### MAINTENANCE:

- 1) At the end of each day's operation, while the generator is pressurized, flip the console toggle switch to the "Blowdown" position, open the door in the cabinet base and open the generator's drain valve (red handle). This "Blowdown" procedure drains the water out of the generator and helps to prevent lime scale formation. When the generator is empty, flip the console toggle switch to the "OFF" position and close the generator's drain valve. It is recommended that the generator be refilled with water after the "Blowdown" is performed. This can be accomplished by flipping the toggle switch to the "ON" position for a period of five minutes and then returning the switch to the "OFF" position.

### CAUTION:

Service on the generator should only be performed by a trained and experienced service technician, thoroughly familiar with servicing steam generators. No work should be done on the steam generator while it is pressurized or hot. Be sure all energy sources are shut off before the start of any work.

2) Even though the "Blowdown" is performed faithfully each day, it will still be necessary to periodically inspect the inside of the generator. The generator's hand hole plate should be removed at regular intervals so that it is removed. If the hand hole plate is chipped or cracked, or over three years old, install a new one. Replace the corrosion resistor if necessary, and chemically descale the generator if it is coated with lime scale. A new hand hole gasket should always be installed.

3) It will be necessary to periodically have scale accumulations removed from the inside of the steam generator by a qualified service technician. Generator descaling instructions are provided on a separate data sheet. Failure to periodically remove scale from the inside of the generator will result in greatly reduced generator life.

4) Every steam generator is equipped with at least one corrosion and scaling. This corrosion resistor is sacrificial and must be replaced at regular intervals just before it is entirely consumed. In areas where the water is very hard, the feedwater must also be treated to remove the harmful mineral content.

Refer to separate data sheets for corrosion resistor servicing instructions, feedwater treatment information, and hand hole plate servicing instructions.

5) Check the safety valve once a week while steam generator is pressurized. Test by pulling safety valve extension wire. Valve must open freely and snap closed when released. If it does not or if it drips constantly, a new safety valve is needed.

6) If the steam generator is to be left idle for three months or more, it should be drained and dried out and the hand hole plate left off.

7) Water level in the sight gauge normally should be about 2/3 full. This level is maintained automatically.

Refer to separate data sheet for either mechanical or water fill servicing instructions.

8) If gas fired the lighting instructions are on the AGA rating plate. Pilot burner is lit through hole in panel at bottom of steam generator. This panel should never be left off as this will damage the controls. Burners will not light without water in the steam generator.



---

#### WATER QUALITY REQUIREMENTS — STEAM GENERATOR PROTECTION AND MAINTENANCE

A steam generator, or boiler unlike other types of water-using kitchen equipment, distills the water in order to make steam. Nearly all feed-water sources contain dissolved minerals in varying degrees of concentration. As this water is boiled, pure steam rises from it's surface, upward to the cooking compartments, leaving minerals behind, that can become harmful to the steam generator. If minerals are allowed to accumulate inside the steam generator, they will solidify as a scale. Then malfunctioning will occur, and serious equipment damage may result.

The use of good quality generator feed water is the responsibility of the owner/user. The use of poor quality feed water could void equipment warranties. The minimum treatment required in most areas is water softening, although local water conditions may require more intensive pretreatment than simply a water softener.

Scale problems occur when feed water is high in hardness, total dissolved solids, silica, and alkalinity. Water softening will only reduce the water's hardness which is the presence of dissolved salts of magnesium and calcium. Water softening will not affect the multitude of other minerals, the best property to control, for generator feed water, is total dissolved solids, not just hardness.

the recommended minimum water quality standards, whether untreated or pretreated, based upon 10hours of use per day, and a Daily Blowdown are as follows:

TOTAL DISSOLVED SOLIDS	less than	60 parts per million
TOTAL ALKALINITY	less than	27 parts per million
SILICA	less than	13 parts per million
pH FACTOR	greater than	7.5

Consult a local water treatment specialist for an on the premises water analysis and for recommendations concerning steam generator and feed water treatment (if required) in order to remove or reduce harmful concentrations of minerals.

If the recommended water quality requirements are met without supplemental treatment or if treatment is applied resulting in feed water quality meeting the prescribed standards the steam generator will need to be blown down only once each day. In addition the inside of the generator requires an inspection (for excessive lime accumulation and consumed corrosion resistors) only once every six months. Replace the corrosion resistor and chemically descale the generator as required.

If a pre-treatment unit cannot be installed, and the recommended water quality requirements are not met, the following procedures should be followed in order to achieve maximum steam generator service life. The steam generator is heavily coated with scale, have it chemically descaled by a qualified service technician.

#### INSTRUCTIONS FOR CHEMICALLY DESCALING STEAM GENERATORS

**Warning: Steam under pressure may cause serious injury and bodily harm when it is accidentally or carelessly released. Improper handling of acid could cause serious permanent injury. Therefore, service of the steam generator should only be performed by trained and experienced personnel, thoroughly familiar with servicing generators.**

There are a number of commercial descaling chemicals available produced by various manufacturers. Those utilizing a sulfamic acid base, which can be identified by its powdered form are safe and compatible with our food preparation equipment. It is imperative that the acid used for descaling be FDA approved for use in food preparation equipment. Various manufacturers may include additional chemicals to increase potency and therefore, instructions are not provided with the delimiting chemical you purchase the following general guidelines may be followed.

**WARNING:** Exercise care when handling acid. Avoid contact with skin, eyes, or clothing. Wear safety glasses or face shield along with rubber gloves and rubber apron. In case of exposure to clothing, remove clothing and flush with water. In case of exposure to skin or eyes, flush with water for 15 minutes and get immediate medical attention. Do not take internally. Keep out of the reach of children.

Be sure the generator has been drained, de-pressurized, and is cool. Open the hand hole access plate on the front of the generator and place approximately 8-10 pounds of sulfamic acid inside the generator. Put a new hand hole plate and replace the hand hole plate tightening the bar and nut assembly to a maximum of 15 foot pounds torque. The generator must be completely filled with hot water (fill the generator beyond its normal, automatic fill point to 2/3 up in the sight gauge.) On mechanical fill generators this can be accomplished by adding weight to the float or removing the float and regulating the fill level with a hand valve in the water supply plumbing. On electric fill generators (with probes) this can be accomplished by temporarily jumpering terminals #3 & #4 of the water control relay. Turn the main on-off toggle switch to the "ON" position then turn the switch to the "OFF" position when the generator is completely filled. Let the solution stand for several hours, then flush with water. Rinse with a solution of bicarbonate of sods to neutralize any acid residue and again flush with water.

**CAUTION:** Never tighten the hand hole plate nut when the steam generator is in use, hot, or otherwise pressurized. Never tighten nut over 15 foot pounds torque. Overtightening may cause uneven stress, which may result in the weakening and possible breakage of the plate.

## MAINTENANCE INSTRUCTIONS FOR STEAM GENERATORS (EXCEPT THOSE EQUIPPED WITH TWO PROBES)

**WARNING: Steam under pressure may cause serious injury and bodily harm when it is accidentally or carelessly released. Therefore, service of the steam generator should only be performed by trained and experienced personnel, thoroughly familiar with servicing steam generators.**

**CAUTION:** Never work on the steam generator when it is hot or pressurized.

Every steam generator shipped is equipped with at least one corrosion resistor (cathodic). The larger capacity steam generators will have two corrosion resistors.

The hand hole plate and gasket on your steam generator stops the escape of steam through the hand hole opening during operation.

- 1) Turn off all energy sources to steam generator. Drain steam generator.
- 2) Remove hand hole cover plate from steam generator.
- 3) Hang corrosion resistor from the right side of the front stay rod, away from the probes. Clean scale and rust off a portion of the stay rod so the hanger will rest on the bright, bare metal.
- 4) Re-install the hand hole plate, along with a new gasket.

The hand hole plate should be cleaned and examined every time it is removed. If the hand hole plate is chipped or cracked or over three years old, install a new one. Because continuous use and possible abuse cause metal fatigue which weakens the hand hole plate, a new one should be installed at least every three years.

**CAUTION: Never tighten the hand hole plate nut when steam generator is in use, hot, or otherwise pressurized. Never tighten nut over 15 foot pounds torque. Overtightening may cause uneven stress, which may result in the weakening and possible breakage of the plate.**

Replace the gasket whenever the hand hole plate is removed or replaced. Keep a spare gasket on hand at all times.

Replace the gasket at least once a year, or sooner if it is cracked, torn, or hardened.

Leakage of water past the hand hole plate should not be allowed to continue as this will cause pitting of the metal in contact with the gasket.

5) After re-installing the hand hole plate, close the steam generator drain valve. Turn on energy sources.

6) Start up and operate steam generator long enough to observe that it is operating properly.

The corrosion resistor is sacrificial and must be replaced at regular intervals just before it is entirely consumed. Frequency of replacement can only be established by a regular inspection for how much of the protector remains and whether scaling or pitting has begun. Scaling indicates a very hard water condition. In either case, more protectors or more frequent replacement of them is necessary. The best way to reduce servicing time and to assure long generator life is to provide feed water that is low in solids content and low in gas content. Water that is fit to drink can still be high in impurities that are highly detrimental to a steam generator. Consult a water treatment specialist in your area for recommendations concerning steam generator feed water treatment.

Under average conditions, the corrosion resistor provides about six months of service. An average condition would meet each of the following tests:

1. Less than 8 hours of steam generation a day.
2. One generator blowdown every day
3. Moderately hard water. Less than 85 ppm.
4. Water containing less than 60 ppm Total Dissolved Solids.

Distribution of hard water in the U.S. is shown on map, right. Areas shown in black have hardest water, while relatively soft water is found in white areas. Shaded areas require supplemental feed water treatment to remove or to reduce the hardness.

This map is a general representation and exceptions do exist. Consult a local water treatment specialist for a water sample test.

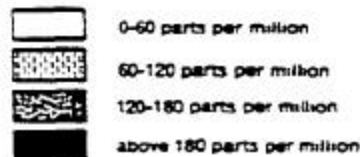

# STEAM GENERATOR (BOILER) IDENTIFICATION

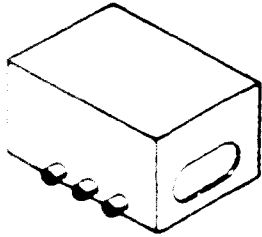
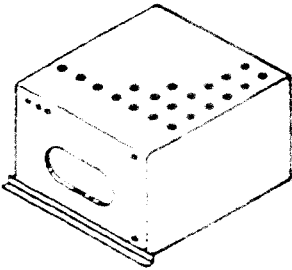
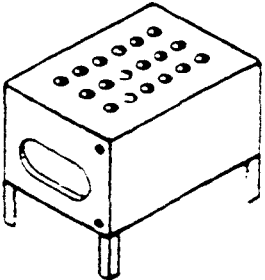
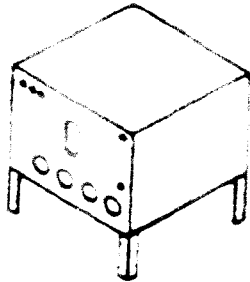
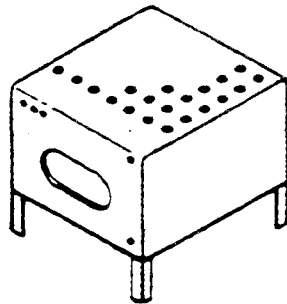
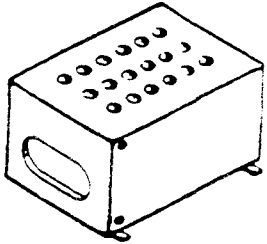
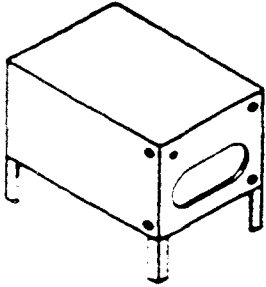
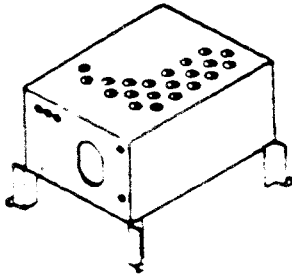
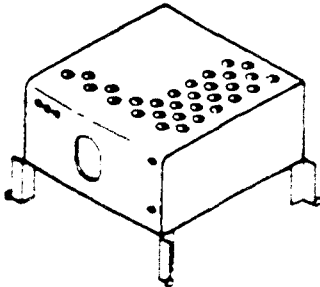
<p><b>ELECTRIC SIDE HEATER SCREW TYPE</b></p>  <p><b>(NOT AVAILABLE)</b></p>	<p><b>GAS 210 M</b></p>  <p><b>PART NO. 403091 • (43833)</b></p>	<p><b>GAS 100-150 M</b></p>  <p><b>PART NO. 40306 • (43826)</b></p>
<p><b>ELECTRIC 24-36-48 KW</b></p>  <p><b>PART NO. 43936 • (43938)</b></p>	<p><b>GAS 210 M</b></p>  <p><b>PART NO. 40718 • (43832)</b></p>	<p><b>GAS 100-150 M</b></p>  <p><b>PART NO. 403071 • (43828)</b></p>
<p><b>STEAMCOIL</b></p>  <p><b>PART NO. 43700 • (43782)</b></p>	<p><b>GAS 180-200 M</b></p>  <p><b>PART NO. 43926 • (40298)</b></p>	<p><b>GAS 250-300 M</b></p>  <p><b>PART NO. 43927 • (40297)</b></p>

**Service Note**  
 The above drawings showing the sight gauge location and method of mounting are for assisting in determining the proper part number for replacement generators. When ordering please provide both the proper part number and the equipment's serial number.



# SERVICING INSTRUCTIONS STEAM PRESSURE ADJUSTMENTS

**WARNING:** Adjustments must be made only by trained and experienced service personnel.

Normally there is no need to make pressure adjustments on a new steamer, because the proper settings are made at the factory. In some cases however, the factory setting may shift due to shaking in transit, and resetting will be required after installation. The factory pressure settings shown on the accompanying chart should never be exceeded.

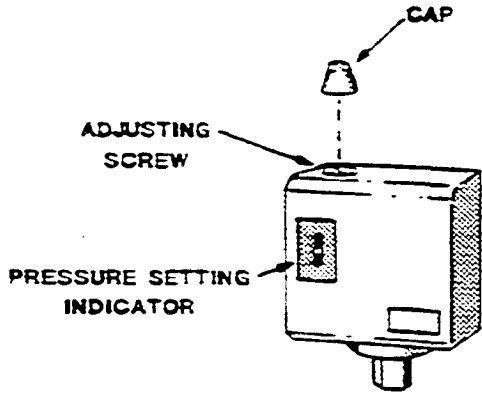

## For Gas and Electric Steam Generator

Steam pressure is controlled with two pressure switches located toward the upper-front of the cabinet either to the extreme right. The left switch is the operating pressure switch. This switch controls the pressure in the steam generator, which is the pressure indicated on the steam generator pressure gauge. The right switch is a high limit, pressure safety control. It breaks an electric circuit to shut off the energy source if the steam pressure rises above a safe level.

Each switch has a screw on top of the case to permit the pressure set point to be adjusted without removing the cover. The correct settings are shown in the accompanying chart. The pressure switch indicator scale is for reference only. Actual pressure should be read on the pressure gauge and the pressure switch adjusted to produce the proper pressure gauge reading. Some models may also have a pressure reducing valve to control the pressure in the steam line to the steamer. The adjustment of this is discussed further on.

## For Steam Coil Steam Generator

The steam supply to steam coil generators is controlled by one of two methods.

Steam generator pressure may be controlled by a pilot operated pressure regulating valve. The steam generator pressure can be adjusted by turning the adjusting collar, identified on the sketch. A steel rod is provided to turn the collar. The correct settings are shown in the accompanying chart.

On steam coil generators equipped with an electric solenoid valve to control the steam supply to the steam generator, one or two pressure switches control the steam generator pressure. To adjust the switch(es), turn the screw on the top of the case to achieve the pressure reading shown in the accompanying chart.

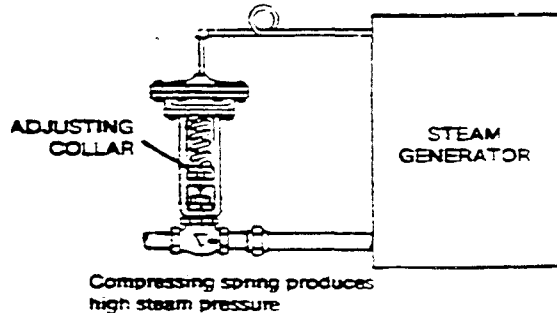

## Pressure Reducing Valve-Adjustment and Care

A screw at the top of the valve body, as shown on the sketch, permits the pressure set point to be adjusted. The locknut must be loosened before adjustment is made, and tightened after. Turning adjustment screw into housing raises pressure. If excessively high or low pressure can't be corrected by adjustment, install a new valve.

To eliminate erratic performance, the internal steam strainer should be cleaned periodically. The strainer can be reached by unscrewing the large hex head plug at the bottom of the valve body.

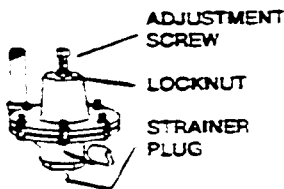

(CONTINUED ON THE REVERSE SIDE)

Equipment	GAUGE PRESSURE READING WITH NO STEAM FLOW (STATIC PRESSURE)						
	Self-Contained Steam Generator Gas or Electric			Self-Contained Steam Coil Generator		Direct Connect ( To House Steam Supply)	
	Steamer's Pressure Reducing Valve	Operating Pressure Switch	High Limit Safety Pressure Switch	Steamer's Pressure Reducing Valve	Pressure Regulati ng Valve or Pressure Switch	Steamer's Pressure Reducing Valve	Kettle's Pressure Reducing Valve
Steam Generator Only 5 PSI	N/A	5 psi	10 psi	N/A	5 psi	N/A	N/A
Pressure Steamer	N/A	5 psi	10 psi	N/A	5 psi	5 psi	N/A
Pressure Steamer With Any Kettles)	5 psi	10 psi	15 psi	5 psi	10 psi	5 psi	20 psi
Steam Generator Only 10 psi	N/A	10 psi	15 psi	N/A	10 psi	N/A	N/A
Kettle Only-All	N/A	10 psi	15 psi	N/A	N/A	N/A	20 psi
Convection Steamer, Super Steamcraft, or "D" Series Defroster With or Without Kettles	N/A	10 psi	15 psi	N/A	10psi	10 psi	20 psi

**CLEVELAND RANGE, INC., 1333 EAST 179th ST.. CLEVELAND, OHIO 44110**  
 Manufacturer reserves right of design improvement or modification as warranted.

## SERVICING INSTRUCTIONS

## PROBE SYSTEM: ELECTRIC WATER FILL AND ELECTRIC LOW WATER FUEL CUT OFF FOR STEAM GENERATOR — 3 PROBE TYPE

WARNING: Service of the steam generator must be performed only by trained and experienced service technicians.

During operation of the steam generator. The water level is maintained automatically by unequal length probe extensions inside. The probes and extensions must be kept clean and free of scale deposits in order to function properly.

The probe extensions are sensors in a control system which monitors and maintains the water level between the end of the short probe extension and the end of the intermediate extension.

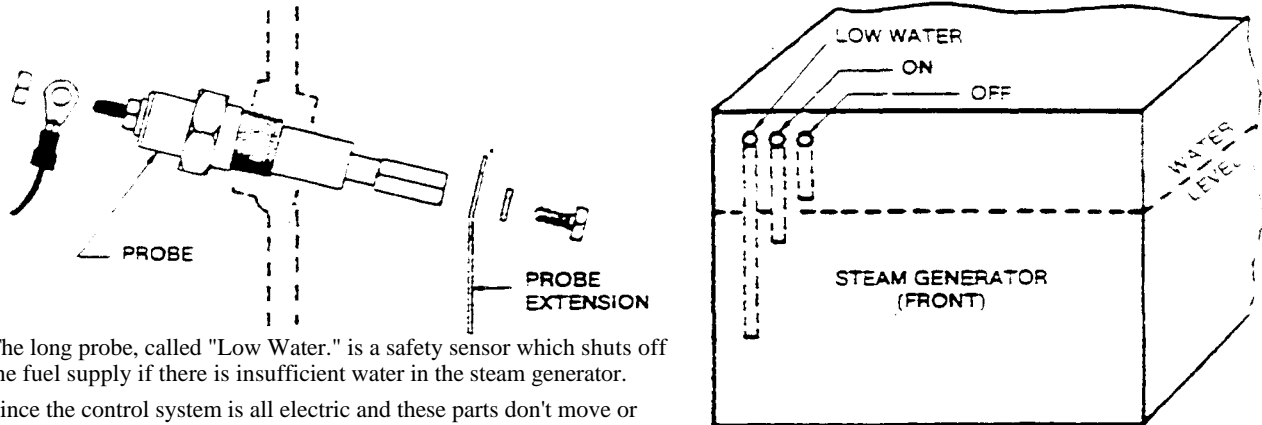

The long probe, called "Low Water," is a safety sensor which shuts off the fuel supply if there is insufficient water in the steam generator.

Since the control system is all electric and these parts don't move or wear, they can be expected to have a long life. If they do malfunction, it is generally because untreated hard feedwater is being used in the steam generator. This forms scale on the submerged ends of the probe extensions and on the top horizontal surfaces of the probes. After this scale is removed, the parts will function properly.

To eliminate the cause of scaling, refer to separate data sheets for feedwater treatment information and corrosion protector servicing instructions. Probes and probe extensions should be wiped clean each time the corrosion protector is replaced.

Erratic operation may result from loose connections on either end of the probe. The external end of the probe has a nut to hold the wiring terminal snugly to the probe. This nut, if loose, may be tightened, firmly but gently. Too much torque will turn the center piece of the probe and misalign the attached probe extension inside, causing the probe to become inoperative.

Inside the steam generator, the screw which holds the probe extension to the probe may be loose, allowing the probe extension to swing or rest against some part of the steam generator. This can be corrected by removing the hand hole plate and reaching inside to align and hold the probe extensions vertically while tightening the screws.

### To Service the Probes or the Probe Extensions

1) Turn off all utilities and fuel to steam generator. Drain Steam generator.

**CAUTION: Never work on the steam generator when it is hot or pressurized.**

- 2) Remove probe cover on outside of steam generator to expose probe terminals. Examine for loose wiring terminals.
- 3) Remove hand hole cover plate from steam generator. See separate data sheet for instructions.
- 4) Remove probe extensions from probes on inside of steam generator, clean off scale, and re-install. Or, install new probe extensions if preferred.
- 5) Remove scale from the probe (see sketch above). Do not use an abrasive on the teflon insulator. If the old probe needs replacement, install a new one.

(CONTINUED ON THE REVERSE SIDE)

CLEVELAND RANGE, INC., 1333 EAST 179th ST., CLEVELAND, OHIO 44110  
Manufacturer reserves right of design improvement or modification, as warranted.

CONTINUES

## SERVICING PROBE SYSTEM: ELECTRIC WATER FILL AND INSTRUCTIONS ELECTRIC LOW WATER FUEL CUT OFF FOR STEAM GENERATOR — 3 PROBE TYPE

6 Assemble probe extensions to probes on inside of steam generator so they hang vertically, parallel to each other. Malfunctioning will occur if an extension touches any part of the steam generator *or* another probe extension.

7) If insulation on electrical wires to the probe shows signs of being broken, cut or deteriorated, the wires should be replaced.

8) Connect wire terminals on outside of steam generator to probe terminals as follows:

Red wire to the shortest probe. Turns water off.

Black wire to the intermediate probe. Turns water on.

White wire to the longest probe- Shuts off fuel (low water safety fuel shut-off).

9) Re-install hand hole plate and install a new gasket.

The hand hole plate should be cleaned and examined each time it is removed. If the plate is chipped or cracked it should be replaced immediately. Because continuous use and possible abuse can cause metal fatigue which weakens the hand hole plate, a new one should be installed at least every three years. Replace the gasket at least once a year—or sooner if it is cracked or hardened.

10) Replace probe cover and check to make sure that the cover does not contact probes.

11) Close steam generator drain valve. Turn on utilities and fuel supply to steam generator.

12) Operate and observe steam generator long enough to insure that it is functioning properly.

### **Low Water Fuel Cut Off Test**

Proper operation of the "Low Water" probe extension should be checked periodically, by someone who is thoroughly familiar with the equipment.

To Test: Open the drain of the steam generator while fuel is on- When the water has drained below the "Low Water" probe, the fuel should shut off automatically- Indication of fuel shut off should occur just as the water level in the sight gauge drops from view. If it does, close the drain, allow the steam generator to refill, and resume normal operations. If the fuel does not shut off, immediately turn the on-off toggle switch to the "off" position, and follow the steps outlined under "To Service the Probes or the Probe Extensions" as given on the reverse side of this sheet.

For specific information pertaining to the operation of the electric water fill controls, and electric low water safety fuel cut-off, refer to the following data sheets:

Electric Steam Generators

Gas-Fired Steam Generators

Steam Coil (electric operated) Generators

CLEVELAND RANGE, INC., 1333 EAST 179th ST., CLEVELAND, OHIO 44110  
Manufacturer reserves right of design improvement or modification, as warranted.

# STANDING PILOT-IGNITION TYPE GAS CONTROLS FOR GAS-FIRED STEAM GENERATORS

**CAUTION:** The following procedures, as well as other work on the gas controls, should be performed only by a trained and experienced service technician, thoroughly familiar with gas controls.

Built in gas controls assure safe and automatic operation of the pilot and main burners of the steam generator

The controls consist of a pilot generator (thermocouple and a unit called the combination gas control This latter unit consists of a gas valve operator and servo gas pressure regulator

Generally, there is no need to make an adjustment to any portion of the gas system. The main burner orifices and the pilot burner orifice installed at the factory are correct for the kind of gas specified on the purchase order Also. the primary air supply to the main burner is properly adjusted for complete combustion.

## Lighting and Shutdown Instructions

Flip electrical switch on. Open water valve Open gas valve Slightly depress and turn control knob to "off" for 5 minutes before lighting gas. Turn control knob to "pilot." depress it completely, and light pilot burner. Continue to hold Knob in for about 60 seconds, then release. Pilot burner is lighted through hole in panel at bottom of steam— generator Never leave panel off. as this will damage controls. Turn control knob to "on". Depress electrical switch. for main burner ignition Burners will not light without water in the steam generator. For main burner off. with pilot on control knob to "pilot". For main and pilot burner off. slightly depress and turn control knob to "off" Flip electrical switch off

Occasionally due to regional differences in the gas supply the pilot burner flame may require adjustment.

A normal flame is mostly blue and steady, and envelops 3/8" to 1/2 of the tip of the pilot generator, as illustrated at right

The pilot gas adjusting screw can be found under a cover screw located near the gas control knob. illustrated below

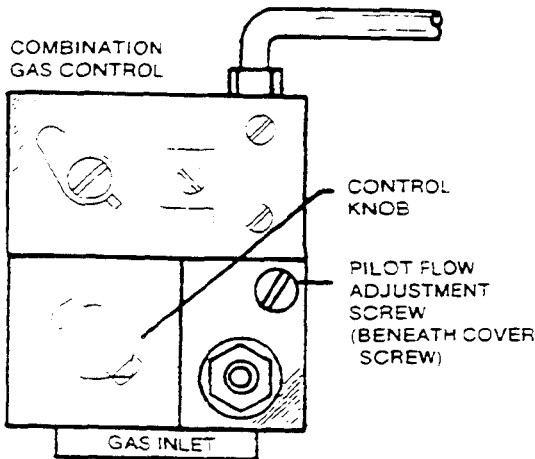
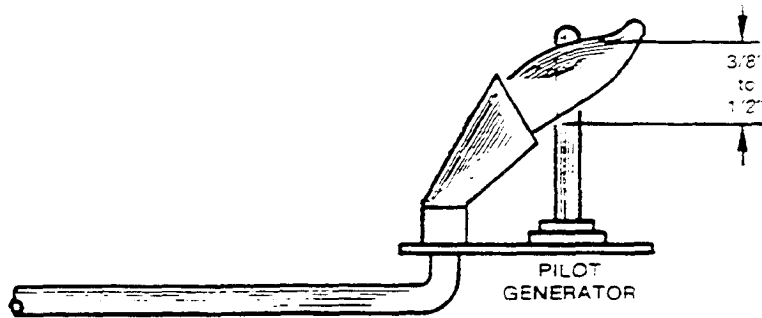

To adjust the pilot flame:

- 1) Remove the pilot adjustment cover screw
- 2 Turn PILOT FLOW ADJUSTMENT SCREW clockwise—to decrease or counterclockwise—to increase pilot flame.
- 3) **WARNING: Be sure to replace cover screw after adjustment to prevent possible gas leakage**

Electrical connections in the pilot generator circuit must be clean and secure.

Because the pilot generator operates in a severe environment, it may eventually need a replacement. The time before replacement will vary from one piece of equipment to another, depending on the amount of usage. The pilot generator (thermocouple) should generate 450-750 MV in an open circuit condition.

When a malfunction is traceable to the combination gas control unit. it is recommended that the entire unit be replaced with a new one. rather than attempting repairs to the old unit.

**WARNING: To prevent the danger of possible gas leakage, the installer must be a trained and experienced service technician, thoroughly familiar with gas controls.**



## HOW THE ELECTRIC (WARRICK RELAY) WATER LEVEL CONTROLS OPERATE — ON GAS FIRED STEAM GENERATORS (WITH 3 PROBES)

Inside Cleveland Range Co- boilers which have electric water level controls, there are three probe extensions vertically oriented above the water with their lower ends positioned at various levels

Water is admitted to the boiler and is shut off in response to the water level sensed by the tips of the short and the medium length probe extensions. The electrical conductance of the water is used in this system for controlling its level.

The third probe extension is a low water safety cutout sensor and operates on the same principle.

### Operation Sequence — Water Level Control

Assume an empty Boiler To fill. close Switch S for the following operations:

- 1) Solenoid SV, is energized allowing the boiler to fill with water at the same time the primary circuit of Transformer T, is also energized.
- 2) The boiler will continue to fill until the water level reaches the Water Off probe extension completing the T, secondary circuit, and energized Relay Coil RC.
- 3) When Relay Coil RC, is energized the normally closed contact opens, de-energizing Solenoid SV; stopping the water fill. The normally open contact is closed, completing the circuit to the Water On probe.

When the water boils away below the end of the Water On probe extension the following occurs:

- 1) The secondary circuit of Transformer T, is broken and the Relay Coil RC, is de-energized
- 2) When Relay Coil RC, is de-energized the normally open contact opens, breaking the circuit to the Water Off probe extension. And the normally closed contact closes, energizing Solenoid SV; allowing the boiler to fill as in Step 2 above.

### Operation — Low Water Safety Cutout

When Switch S is closed the following operations occur

- 1) The primary circuit of Transformer T2; is energized.
- 2) When the water level reaches the low water safety cutout probe extension and the momentary reset switch is manually closed. Relay Coil RC, is energized.
- 3) When Relay Coil RC; is energized the normally open contacts close, completing the low water safety circuit through Contacts 7 and 8 and completing the circuit through Contacts 3 and 4, completing the 750 millivolt pilot generator circuit and allowing the gas control package valve to operate.

If the water level drops below the Low Water Safety Cutout probe extension, the following occurs:

- 1) The secondary circuit of Transformer T2 is broken and the Relay Coil RC2 is de-energized- Contacts 7 and 8 and 3 and 4 open, breaking the 750 millivolt circuit

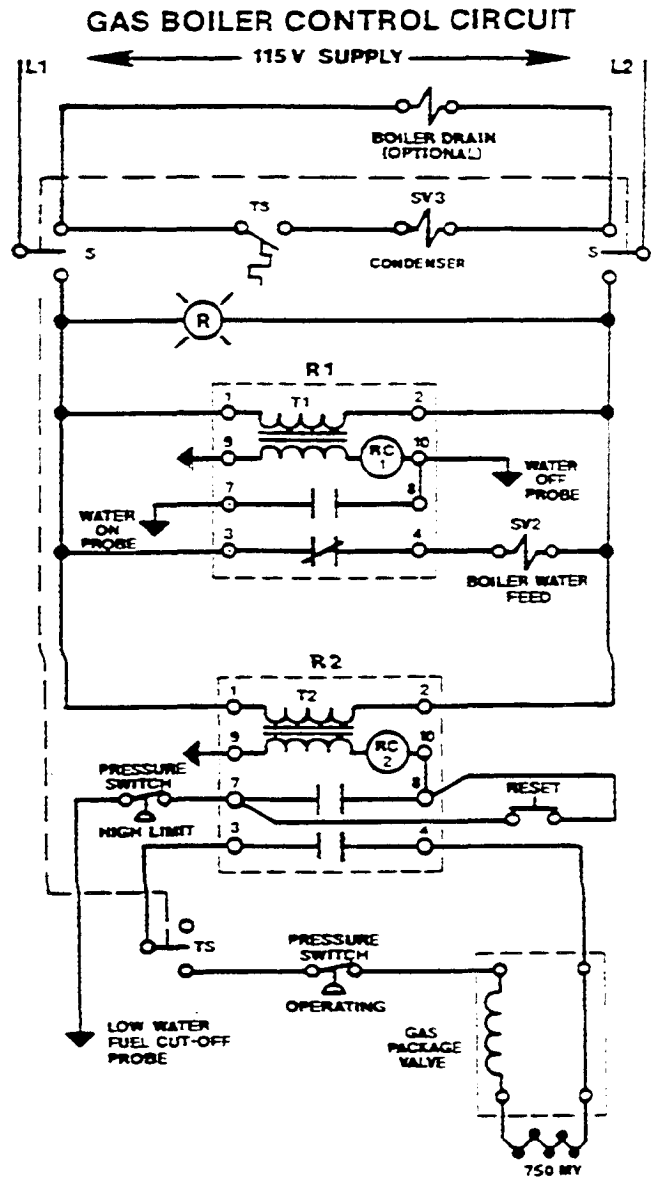

which shuts off the flow of gas to the burners.

The burners will not operate until water level in the boiler is normal and the reset switch is operated.

### Operation-Boiler Drain Condenser

To activate the Boiler Drain Condenser System close switch S by placing toggle in the down position.

To drain boiler, open boiler drain ball valve. The heat from the boiler drain water will close the normally open thermal switch TS and energize the condenser solenoid valve SV. To de-activate the Boiler Drain Condenser System open switch S by moving toggle to center off position.

**HOW THE ELECTRIC (WARRICK RELAY)  
WATER LEVEL CONTROLS OPERATE — ON  
ELECTRIC STEAM GENERATORS (WITH 3  
PROBES)**

inside Cleveland Range Co- boilers which have electric water level controls, there are three probe extensions vertically oriented above the water with their lower ends positioned at various levels. Water is admitted to the boiler and is shut off in response to the water level sensed by the tips of the short and the medium length probe extensions. The electrical conductance of the water is used in this system for controlling its level.

The third probe extension is a low water safety cutout sensor and operates on the same principle. **Operation Sequence — Water Level Control**

Assume an empty boiler. To fill, close Switch S for the following operations:

1) Solenoid SV<sub>1</sub> is energized allowing the boiler to fill with water at the same time the primary circuit of Transformer T<sub>1</sub> is also energized.

2) The boiler will continue to fill until the water level reaches the Water Off probe extension completing the T<sub>1</sub> secondary circuit, and energizing Relay Coil RC<sub>1</sub>.

3) When Relay Coil RC<sub>1</sub> is energized the normally closed contact opens, de-energizing Solenoid SV<sub>2</sub> stopping the water fill. The normally open contact is closed, completing the circuit to the Water On probe.

When the water boils away below the end of the Water On probe extension the following occurs:

1) The secondary Circuit of Transformer T<sub>1</sub> is broken and the Relay Coil RC<sub>1</sub> is de-energized.

2) When Relay Coil RC<sub>1</sub> is de-energized the normally open contact opens, breaking the circuit to the Water Off probe extension. And the normally closed contact closes, energizing Solenoid SV<sub>2</sub> allowing the boiler to fill as in Step 2 above.

**Operation — Low Water Safety Cutout**

When Switch S is closed the following operations occur

1) The primary circuit of Transformer T<sub>2</sub> is energized.

2) When the water level reaches the low water safety cutout probe extension and the momentary reset switch is manually closed. Relay Coil RC<sub>2</sub> is energized.

3) When Relay Coil RC<sub>2</sub> is energized the normally open contacts close, completing the low water safety circuit through Contacts 7 and 8, and completing the circuit through Contacts 3 and 4, energizing Contactor Coil C which closes the heater circuit

If the water level drops below the Low Water Safety Cutout probe extension, the following occurs:

1) The secondary circuit of Transformer T<sub>2</sub> is broken and the Relay Coil RC<sub>2</sub> is de-energized. Contacts 7 and 8 and 3 and 4 open, breaking the circuits to Contactor C., thereby turning off the heaters.

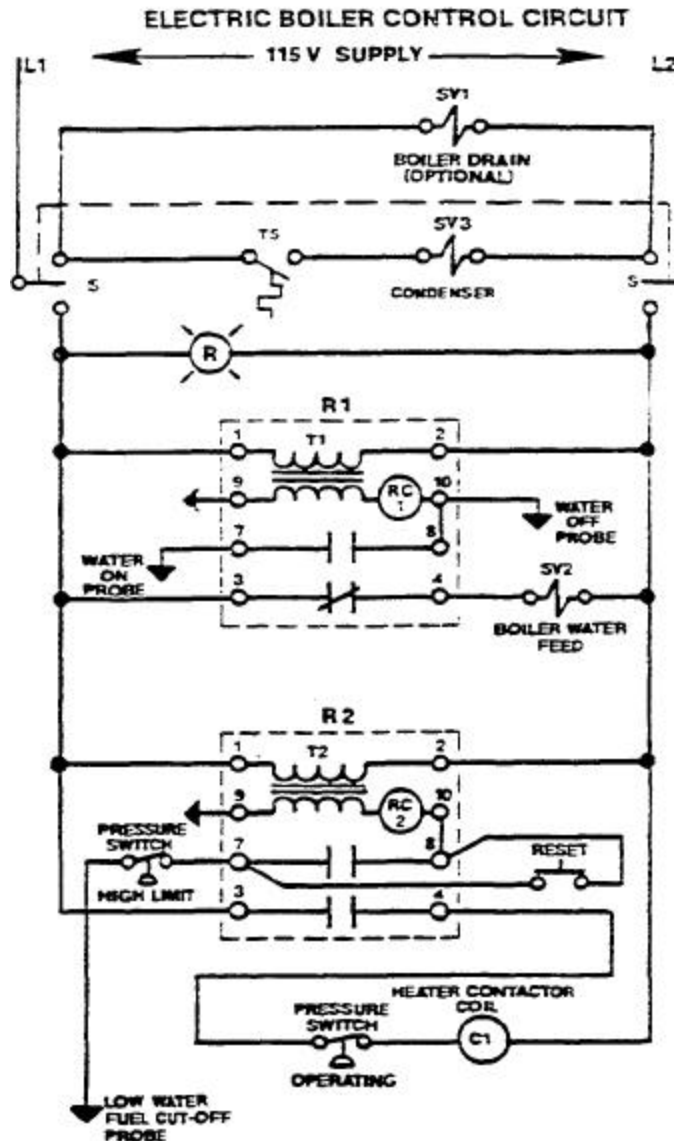

The Contactor C, will not operate until water level in the boiler is normal and the reset switch is operated.

**Operation-Boiler Drain Condenser**

To activate the Boiler Drain Condenser System, close switch S by placing toggle in the down position.

To drain boiler, open boiler drain ball valve. The heat from the boiler drain water will close the normally open thermal switch TS and energize the condenser solenoid valve SV<sub>3</sub>. To de-activate the Boiler Drain Condenser System open switch S by moving toggle to center off position.

ELECTRIC STEAM GENERATOR (BOILER) ASSEMBLY - 3 PROBE TYPE  
24KW, 36KW, & 48KW (2, 3, & 4 HEATER ELEMENTS) - 1968 to PRESENT

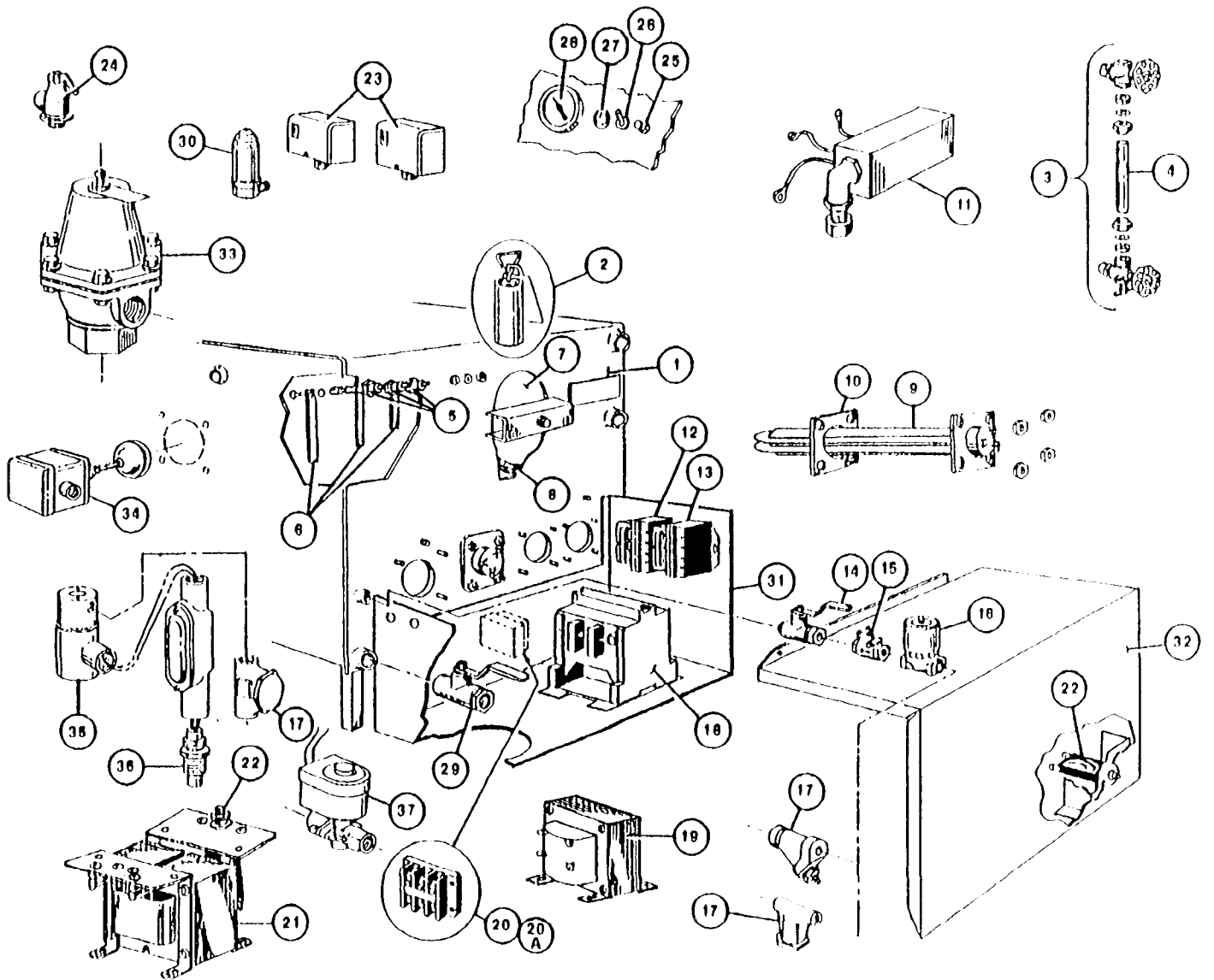

## ELECTRIC STEAM GENERATOR (BOILER) ASSEMBLY — 3 PROBE TYPE 24KW, 36KW, & 48KW (2, 3, & 4 HEATER ELEMENTS) — 1968 to PRESENT

REFERENCE NUMBER	PART NUMBER	DESCRIPTION
1	43936	Boiler shell only with loose hand hole plate assembly mounting studs for 3" square-flanged heater elements.
	43938	Boiler shell (43937) above. also including two corrosion resistors, sight gauge, three probes and extensions with cover box.
2	43895	Corrosion resistor, with hanger
3	40445	Water gauge set with glass.
	07106	Fibre washer (2 required)
	23132	Gauge glass washer (2 required).
4	07302	Glass only 6' long.
5	40462	Probe with lock washer and screw
6	101467	Probe extension set (3).
7	40421	Hand note plate ass-y.. including bar. nut. and gasket
	4374S	Hand hole plate only.
8	07106	Hand note gasket, flat. 4- x 6" oval
9	08165	Electric immersion heater. with gasket. 3" flange. 12KW. 208/220 volt. 3 phase.
	08166	Electric immersion heater, with gasket. 3" flange. 12KW. 230/240 volt, 3 phase.
	08167	Electric immersion heater, with gasket. 3" flange. 12KW. 440/480 volt. 3 phase.
	08214	Electric immersion heater, with gasket. 3" flange. 12KW. 208/220 volt 1 phase.
	08215	Electric immersion heater, with gasket. 3" flange. 12KW. 230/240 volt, 1 phase.
	08216	Electric immersion heater, with gasket. 3" flange. 12KW. 440/480 volt. 1 phase.
	08175	Electric immersion heater. with gasket. 2 1/2 " flange, 12KW. 208/220 volt. 3 phase.
	08176	Electric immersion heater with gasket. 2 1/2" flange, 12KW. 230/240 volt. 3 phase
	08177	Electric immersion heater, with gasket. 2 1/2" flange, 12KW. 440/480 volt. 3 phase
10	07128	Heater gasket — 3" square.
	07115	Heater gasket — 2 1/2" square.
11	53250	Probe cover.
12	03504	Water control relay, 115 volt (1D1DO).
13	03514	Low water cut-off relay. 115 volt. (1C1DO).
14	03276	1/4 " ball valve water supply shutoff.
15	22102	1/4" check valve.
16	44095	1/2" water teed solenoid valve
17	19870	1/4" " line Strainer.
18	03509	Contactoer — 50 amp.
	03506	Contactoer — 75 amp.
19	20533	Transformer 75VA (All. except Convection Steamers).
20	02193	Heavy duty terminal block — use with more than one contactor (125 amp size).
20A	02196	Heavy duty terminal block — use with more than one contactor (250 amp size).
		24KW. 220 volt single phase and 48KW. 208. 220 & 240 volt. three phase.
21	20535	Transformer. 150VA, (Convection Steamers only).
22	03202	Circuit breaker for 20535.
23	19947	Pressure switch (Models after 1-70)
24	22130	Safety valve — 8 psi
	22131	Safety valve — 15 psi
25	19968	Reset switch.
26	19944	On-Off power switch. 115/220 volt DPST (before 1-78).
	19967	On-Off power switch. 115 volt 3PDT (after 1-78) and all auto blowdown.
27	12161	Signal light. 115/220 volt. 1"
	12169	Signal light. 115/220 volt. 1/2" (Pressure Steamers only).
28	07173	Steam pressure gauge, rear mount. 0-30 psi. 2 1/2".
	07168	Steam pressure gauge, rear mount. 0-30 psi. 2" (Pressure Steamers only)
29	03277	Generator drain valve — ball type.
30	22140	Air vent.
31	40471	Control enclosure.
32	52558	Cover, control enclosure.
33	22122	3/4" pressure reducing valve. 3-15 psi output (optional).
34	19945	Float switch with gasket — low water cut off (California only).
35	22104	1/4 ~ solenoid valve — boiler condenser water supply
36	19975	Thermal switch — boiler condenser.
37	22106	Valve, solenoid. 1/2" boiler auto blowdown. 115 volt (optional).

CLEVELAND RANGE CO., 1333 EAST 179th ST., CLEVELAND, OHIO 44110  
 Manufacturer reserves right of design improvement or modification, as warranted.

**ELECTRIC STEAM GENERATOR (BOILER) ASSEMBLY**  
18KW, 27KW, and 36KW (3 ELEMENTS — 6, 9, or 12KW EACH) —  
PRIOR TO 1968

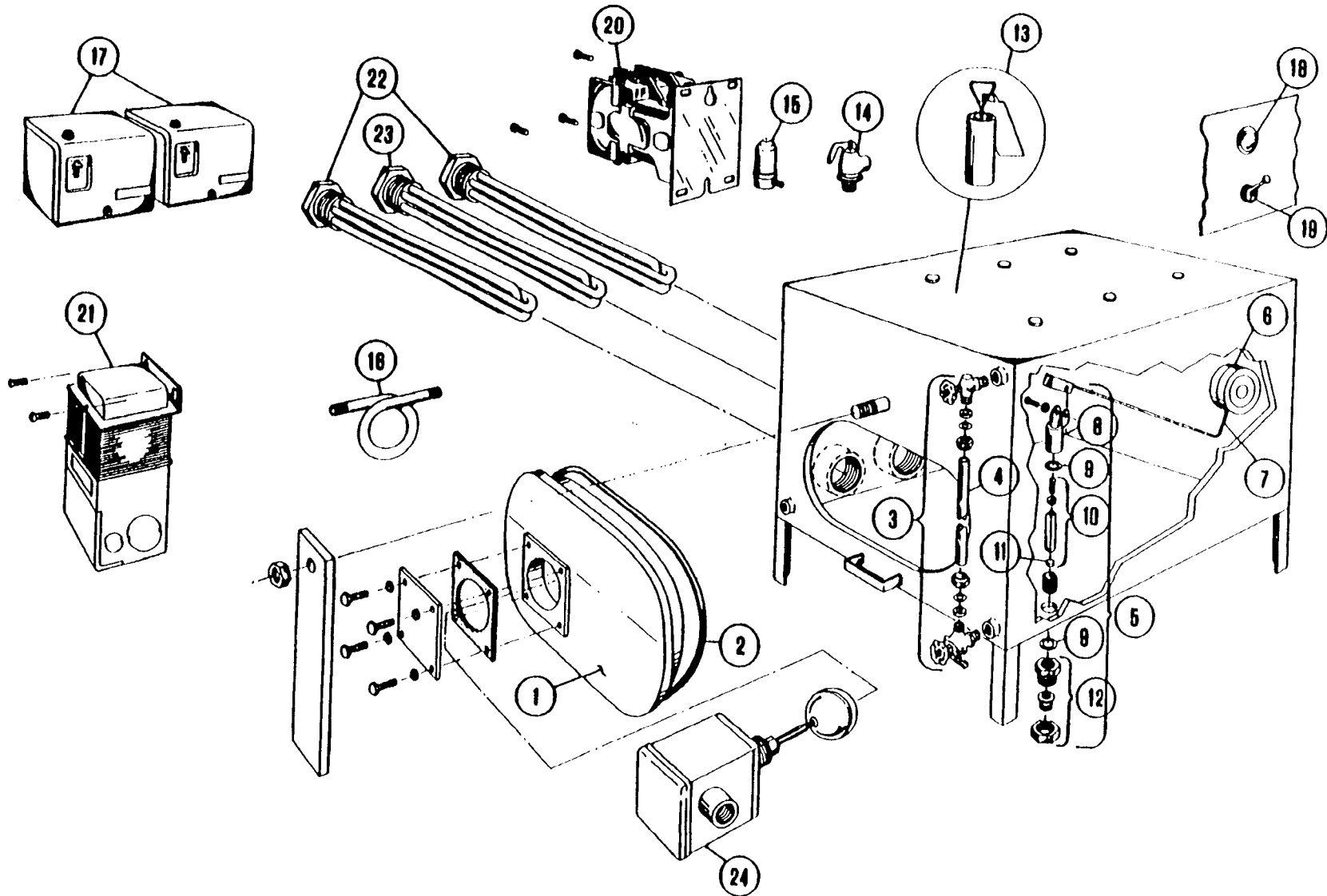

REFERENCE NUMBER	PART NUMBER	DESCRIPTION
1	40425	Hand Hole Plate Assembly
	16650	Hand Hole Plate Only
2	07116	Hand Hole Gasket
3	40446	Water Gauge Set With Glass
	07108	Fibre Washer (2 Required)
	23132	Gauge Glass Washer (2 Required)
4	07301	Glass Only — 10 1/2" Long
5	43720	Water Regulator Valve Assembly
6	06300	Float Only
7	43740	Float Arm and Block Assembly
8	02411	Float Pivot Bracket
9	23 130	Sealing Washer
10	43735	Float Plunger Assembly. 3 1/2"
11	16833	Plunger Disc
12	43724	Water Regulator Valve Sub-Assembly
13	43895	Corrosion Resistor
14	22130	Safety Valve — 8 psi
	22131	Safety Valve — 15 psi
15	22140	Air Vent
16	16820	Pigtail. 1/4" ips
17	19947	Pressure Switch
18	12161	Signal Light 115/220 Volt
19	19944	On-Off Power Switch. 115/220 Volt DPST
20	03503	Contacto <sup>r</sup> tor Side Heater. 50 amp. 208/240 Volt Coil
	03505	Contacto <sup>r</sup> tor Side Heater. 75 amp. 208/240 Volt Coil
21	20532	Transformer — Optional (480/240/120 Volt Only)
22	08170	Electn <sup>c</sup> Immersion Heater. Screw Type. 6KW. 208 Volt
	08171	Electn <sup>c</sup> Immersion Heater. Screw Type. 6KW. 240 Volt
	08184	Electric Immersion Heater. Screw Type. 6KW. 480 Volt
	08172	Electric Immersion Heater. Screw Type. 9KW. 208 Volt
	08180	Electric Immersion Heater. Screw Type. 9KW. 240 Volt
	08185	Electric Immersion Heater. Screw Type. 9KW. 480 Volt
	08182	Electric Immersion Heater. Screw Type. 12KW. 208 Volt
	08181	Electn <sup>c</sup> immersion Heater. Screw Type. 12KW. 240 Volt
	08183	Electric Immersion Heater. Screw Type. 12KW. 480 Volt
23	08201	Heater. Screw Type. With Thermostat. 6KW. 208 Volt (Not Available)'
	08200	Heater. Screw Type. With Thermostat. 6KW. 240 Volt
	08204	Heater. Screw Type. With Thermostat 6KW. 480 Volt
	08203	Heater. Screw Type. With Thermostat 9KW. 208 Volt (Net Available)*
	08202	Heater. Screw Type. With Thermostat 9KW. 240 Volt (Not Available)'
	08205	Heater. Screw Type. With Thermostat 9KW. 480 Volt (Not Available)'
24	19945	Float Switch With Gasket — Low Water Cut-off

• Consult factory *for* conversion to a low water cut-off float switch type of safety circuit

CLEVELAND RANGE, INC., 1333 EAST 179th ST., CLEVELAND, OHIO 44110  
 Manufacturer reserves right of design improvement or modification, as warranted.

# WIRING DIAGRAM ELECTRIC STEAM GENERATORS

WIRING DIAGRAM FOR ELECTRIC STEAM GENERATORS  
WITH ELECTRICAL LOW-WATER HEATER CUTOFF, WITHOUT  
MANUAL SAFETY RESET CIRCUIT PRIOR TO JANUARY, 1978

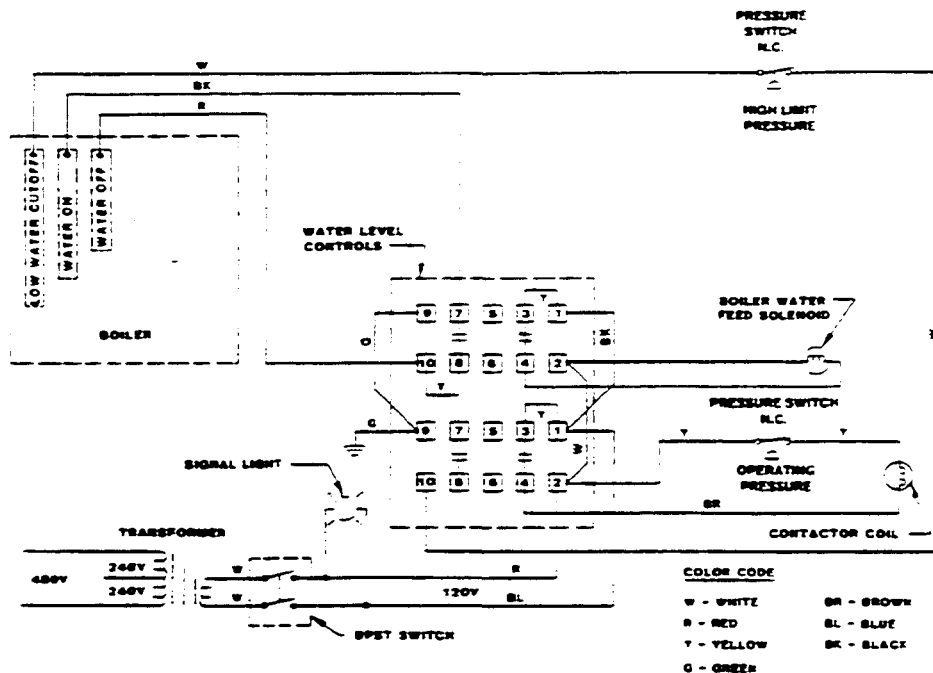

# WIRING DIAGRAM FOR ELECTRIC STEAM GENERATORS WITH ELECTRICAL LOW-WATER HEATER CUTOFF, WITH MANUAL SAFETY RESET CIRCUIT AFTER JANUARY, 1978

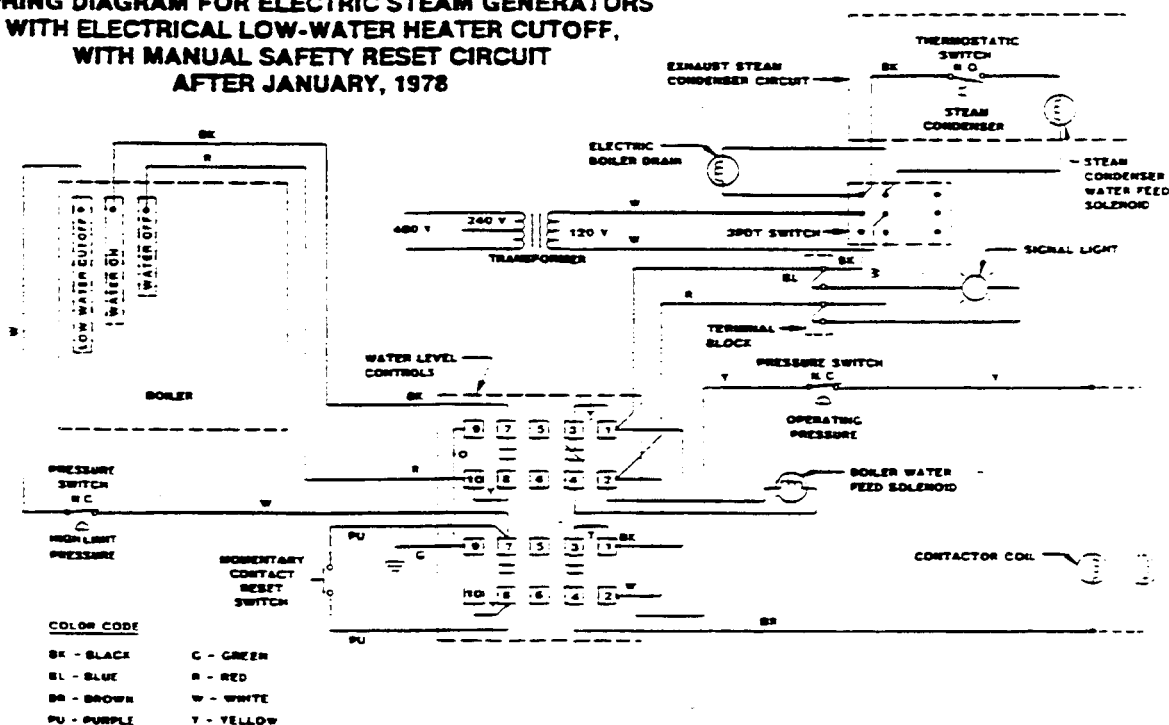

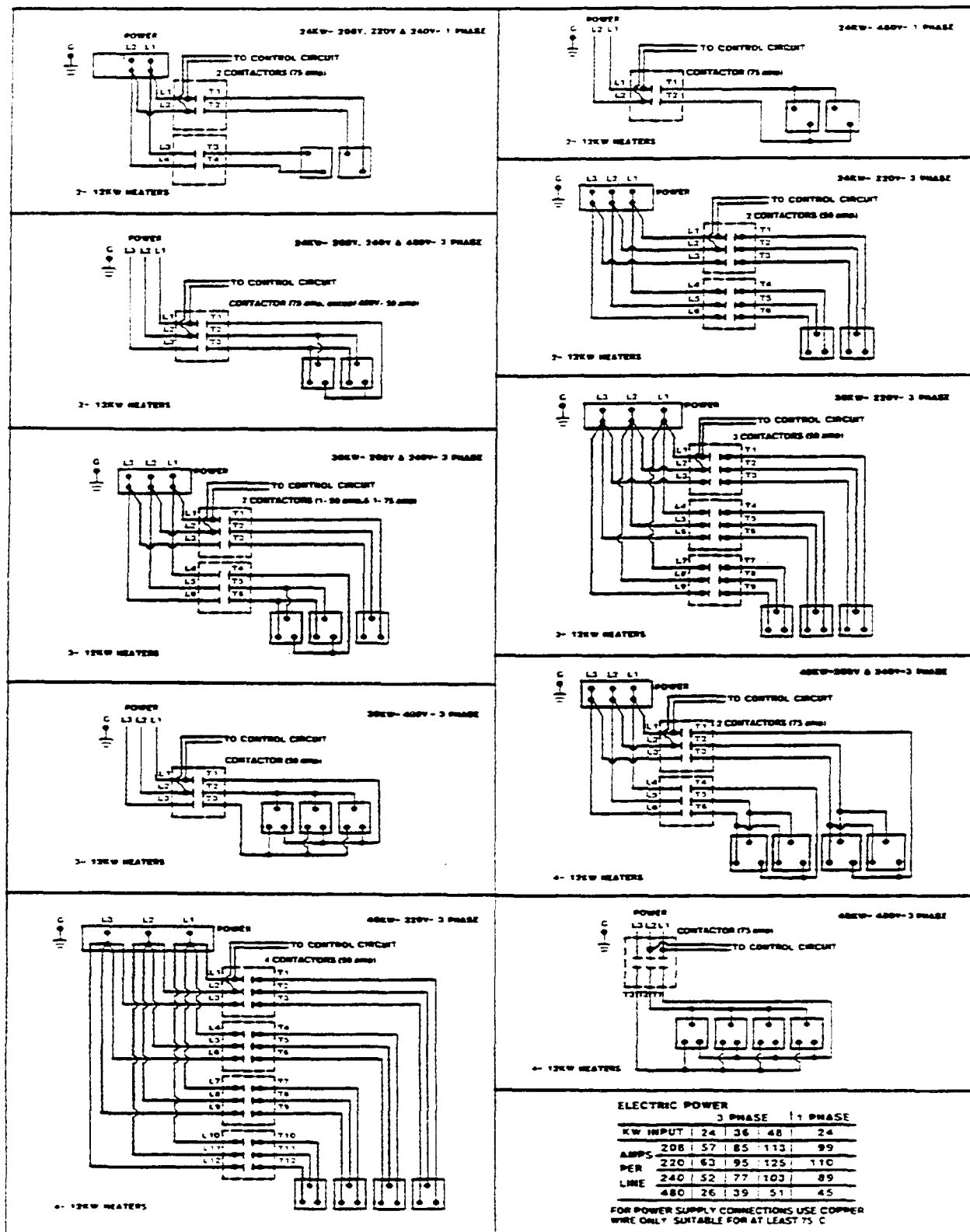

**ELECTRIC POWER**

	3 PHASE			1 PHASE
KW INPUT	24	36	48	24
AMPS	208	57	85	113
PER	220	63	95	125
LINE	240	52	77	103
	480	26	39	51

FOR POWER SUPPLY CONNECTIONS USE COPPER WIRE ONLY SUITABLE FOR AT LEAST 75 C



**GAS STEAM GENERATOR (BOILER) ASSEMBLY — NO PROBES**  
**100,000 BTU (2 BURNER) & 150,000 BTU (3 BURNER)**

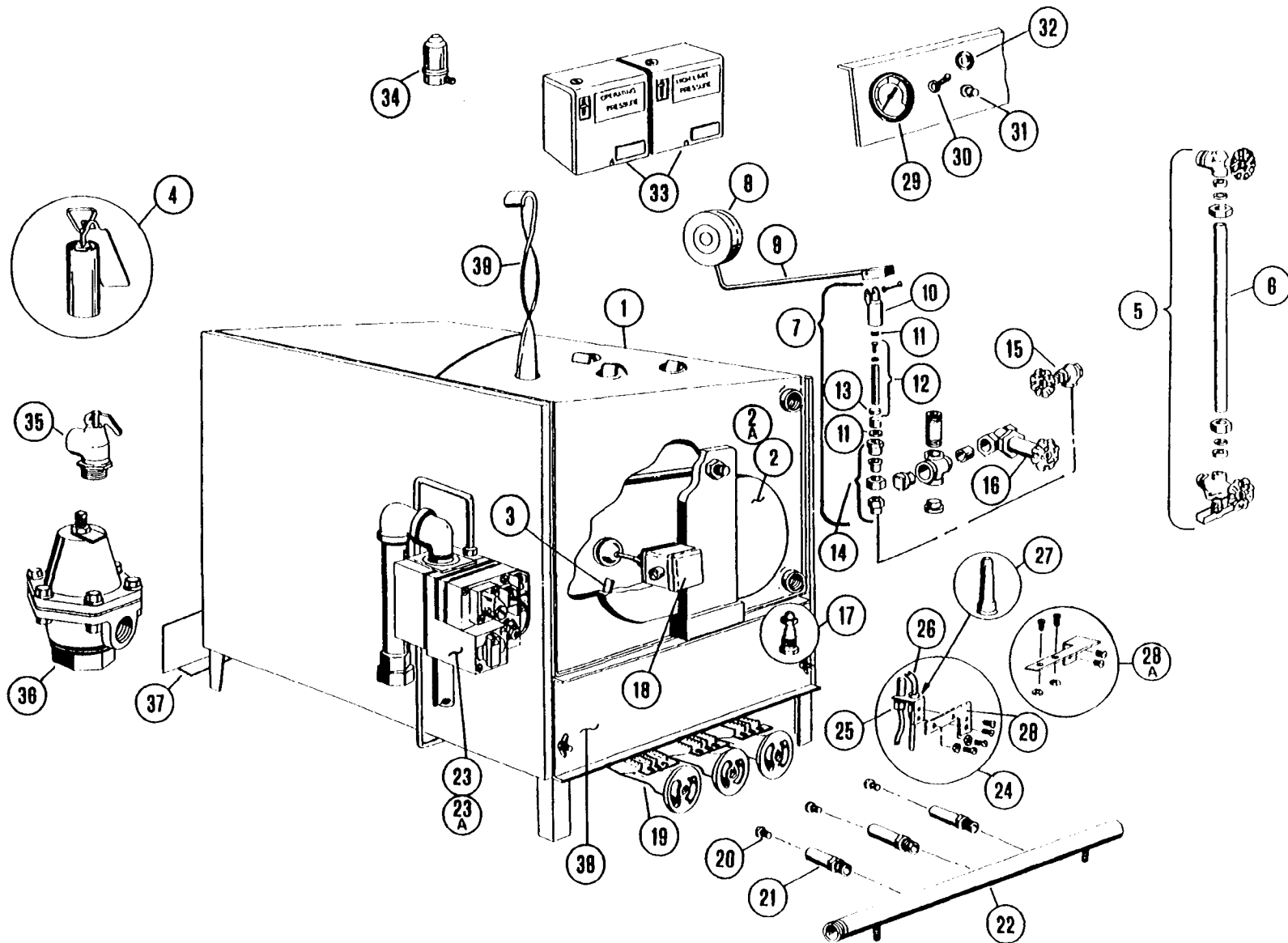

## GAS STEAM GENERATOR (BOILER) ASSEMBLY — NO PROBES 100,000 BTU (2 BURNER) & 150,000 BTU (3 BURNER)

REFERENCE NUMBER	PART NUMBER	DESCRIPTION
1	40300 40307 43826  43828	Boiler Shell Only. With Lees. Studs. Hand Hole Plate Assembly, and Top Flue Bracket. Boiler Shell Only, With Clip Locks, Studs. Hand Hole Plate Assembly, and Top Flue Bracket Boiler Shell 40300 Above. Also Including One Corrosion Resistor. Sight Gauge. Low Water Cut-Off Switch, and Water Regulator. Boiler Shell 40307 Above. Also Including One Corrosion Resistor. Sight Gauge. Low Water Cut-Off Switch, and Water Regulator.
2	40425	Hand Hole Plate Assembly Including Bar, Nut, Gasket, and Hand Hole Plate
2A	16545	Hand Hole Plate Only
3	07116	Hand Hole Gasket
4	43895	Corrosion Resistor
5	40446 07108 23132	Water Gauge Set With Glass Fibre Washers (2 Req'd.) Gauge Glass Washers (2 Req'd.)
6	07301	Glass Only—10 1/2" Long
7	43720	Water Regulator Valve Assembly
8	06300	Float Only
9	43740	Float Ann and Block Assembly
10	02411	Float Pivot Bracket
11	23130	Sealing Washer
12	43735	Float Plunger Assembly, 3 1/2"
13	16833	Plunger Disc
14	43724	Water Regulator Valve Sub-Assembly
15	22112	Water Shut Off Angle Valve
16	22150	3/4" Boiler Drain Valve
17	16621	Fusible Plug With Bushing
18	19945	Float Switch With Gasket—Low Water Cut-Off
19	02498 02499 02501	Main Gas Burner—24" Long Main Gas Burner—20" Long Main Gas Burner Used on Units Built Before 7/76 (not shown). Replace With Burner 02498 (24" Long) or 02499 (20" Long). 1963 Orifice Holder, and One 52450 Pilot Bracket (If Pilot's Burner is Replaced.)
20	15453 15450	Main Burner Orifice—Natural Gas Main Burner Orifice—LP Gas
21	19632 19631	Orifice Holder (After 7/76) Orifice Holder (Before 7/76)
22	63150 63151	Gas Manifold—100,000 BTU—2 Burner Gas Manifold—150,000 BTU—3 Burner
23	22182 22096	1/2" Combination Natural Gas Control Valve 1/2" Combination LP Gas Control Valve
24	43651  43653	Pilot Generator Assembly With 02505 Burner. 20410 Thermocouple. 52449 Bracket and 15460 Orifice. Pilot Generator Assembly with 02523 Burner. 20410 Thermocouple. 52449 Bracket, and 15461 Orifice.
25	20410	Pilot Thermocouple
26	02505 02523	Pilot Burner—Natural Gas Pilot Burner—LP Gas
27	15460 15461	Pilot Burner Orifice—Natural Gas Pilot Burner Orifice—LP Gas
28	52449	Pilot Bracket (After 7/76)
28A	52450	Pilot Bracket (Before 7/76)
29	07173	Pressure Gauge. Rear Mount—0 to 30 psi
30	19967	On-Off Power Switch. 115/220 Volt 3 PDT
31	19968	Reset Switch
32	12161	Signal Light. 115/220 Volt
33	19947	Pressure Switch
34	22140	Air Vent
35	22130 22131	Safety Valve—8 psi Safety Valve—15 psi
36	22122	3/4" Pressure Reducing Valve. 3-15 psi Output (Optional)
37	69934 69935	Rear Baffle and Burner Support—100,000 BTU—2 Burner Rear Baffle and Burner Support—150,000 BTU—3 Burner
38	52171 52172	Burner Compartment Front Baffle—100,000 BTU—2 Burner Burner Compartment Front Baffle—150,000 BTU—3 Burner
39	70920	Twister

**CLEVELAND RANGE, INC., 1333 EAST 179th ST., CLEVELAND, OHIO 44110**

Manufacturer reserves right of design improvement or modification, as warranted.

**GAS STEAM GENERATOR (BOILER) ASSEMBLY — 3 PROBE TYPE  
210,000 BTU (5 BURNERS)**

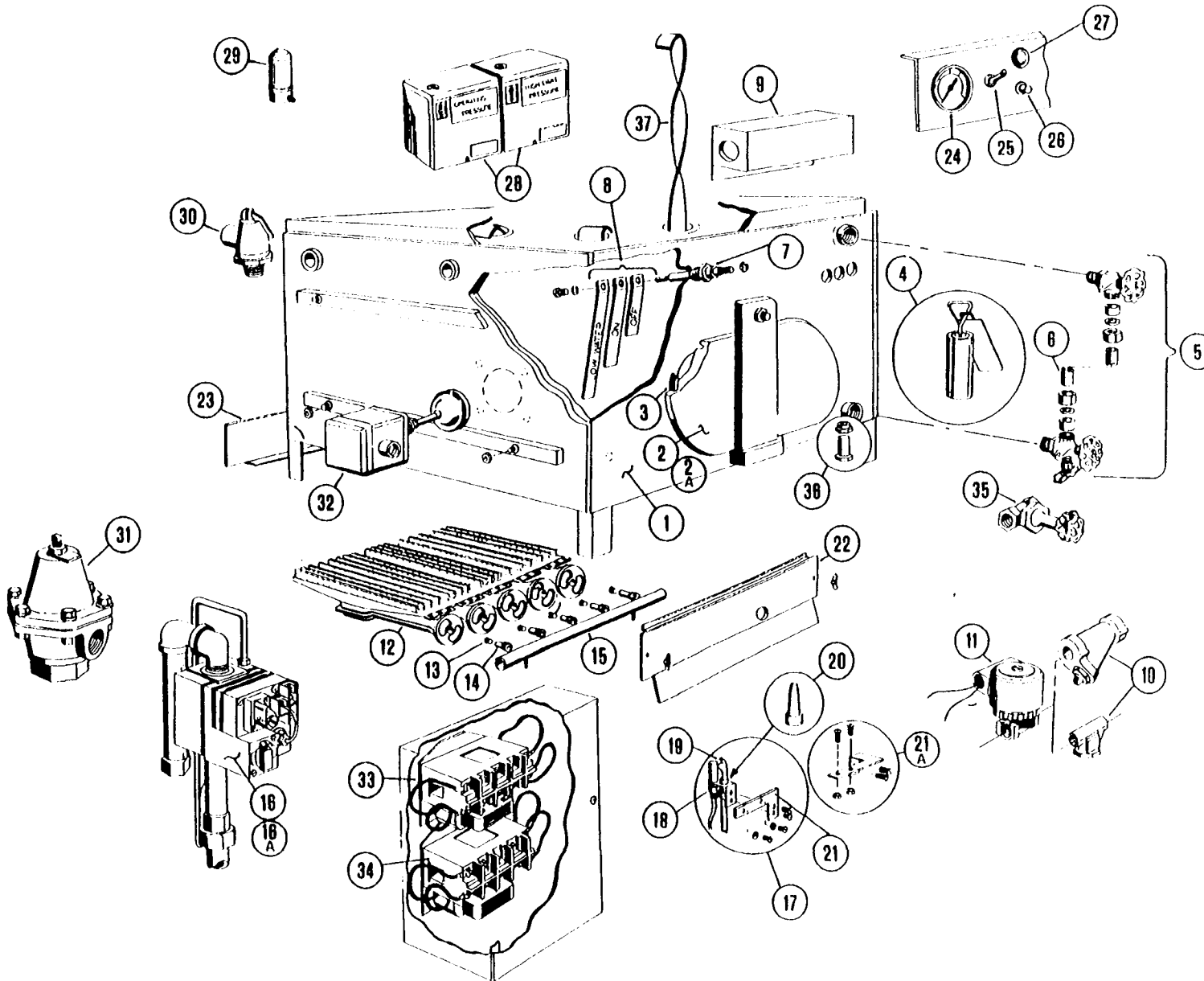

## GAS STEAM GENERATOR (BOILER) ASSEMBLY — 3 PROBE TYPE 210,000 BTU (5 BURNERS)

REFERENCE NUMBER	PART NUMBER	DESCRIPTION
1	40302 40309	Boiler Shell Only. With Legs. Studs. Hand Hole Plate Assembly. and Top Flue Bracket. Boiler Shell Only, With Angle Iron Mounting Bar, Studs. Hand Hole Plate Assembly, and Top Flue Bracket.
	43832	Boiler Shell 40302 Above, Also Including: Two Corrosion Resistors. Sight Gauge. Three Probes and Extensions With Cover Box.
	43833	Boiler Shell 40309 Above, Also Including: Two Corrosion Resistors. Sight Gauge, Three Probes and Extensions With Cover Box.
2	40425	Hand Hole Plate Assembly Including Bar, Nut. and Gasket
2A	16545	Hand Hole Plate Only
3	07116	Hand Hole Gasket
4	43895	Corrosion Resistor (2 Req'd.)
5	40446	Water Gauge Set With Glass
	07108	Fibre Washers (2 Req'd.)
	23132	Gauge Glass Washers (2 Req'd.)
6	07301	Glass Only, 10 1/2" Long
7	40462	Probe With Lockwasher and Screw
8	40455	Probe Extension Set
9	52350	Probe Cover
10	19870	1/4" Line Strainer
11	44095	1/2" Water Feed Solenoid Valve
12	02499	Main Gas Burner
	02500	Main Gas Burner Used on Units Built Before 7/76 (Not Shown). Replace With Burner 02498—24" Long or 02499—20" Long. 19632—Orifice Holder, and One 52450—Pilot Bracket (If Pilot's Burner Is Replaced.)
13	15453	Main Burner Orifice—Natural Gas
	15450	Main Burner Orifice—LP Gas
14	19632	Orifice Holder (After 7/76)
	19631	Orifice Holder (Before 7/76)
15	63152	Gas Manifold—210,000 BTU—5 Burner
16	22183	3/4" Combination Natural Gas Control Valve
16A	22189	3/4" Combination LP Gas Control Valve
17	43651	Pilot Generator Assembly With 02505 Burner, 20410 Thermocouple. 52449 Bracket, and 15460 Orifice.
	43653	Pilot Generator Assembly With 02523 Burner, 20410 Thermocouple, 52449 Bracket, and 15461 Orifice.
18	20410	Pilot Thermocouple
19	02505	Pilot Burner—Natural Gas
	02523	Pilot Burner—LP Gas
20	15460	Pilot Burner Orifice—Natural Gas
	15461	Pilot Burner Orifice—LP Gas
21	52449	Pilot Bracket (After 7/76)
21A	52450	Pilot Bracket (Before 7/76)
22	52177	Burner Compartment Front Baffle
23	69933	Burner Compartment Rear Baffle
24	07173	Pressure Gauge. Rear Mount—0 to 30 psi
25	19941	On-Off Power Switch, 115/220 Volt. 4 PDT
26	19968	Reset Switch
27	12161	Signal Light 115/220 Volt
28	19947	Pressure Switch
29	22140	Air Vent
30	22130	Safety Valve—8 psi
	22131	Safety Valve—15 psi
31	22122	3/4" Pressure Reducing Valve. 3-15 psi Output (Optional)
32	19945	Float Switch With Gasket—Low Water Cut-Off
33	03504	Water Control Relay, 115 Volt (1D1DO)
34	03514	Low Water Cut-Off Relay, 115 Volt (1C1DO)
35	22150	3/4" Boiler Drain Valve
36	16621	Fusible Plug With Bushing
37	70920	Twister

**CLEVELAND RANGE, INC., 1333 EAST 179th ST., CLEVELAND, OHIO 44110**  
Manufacturer reserves right of design improvement or modification, as warranted.

**GAS STEAM GENERATOR (BOILER) ASSEMBLY — 3 PROBE TYPE  
160,000 BTU (3 BURNER) & 200,000 BTU (4 BURNER)**

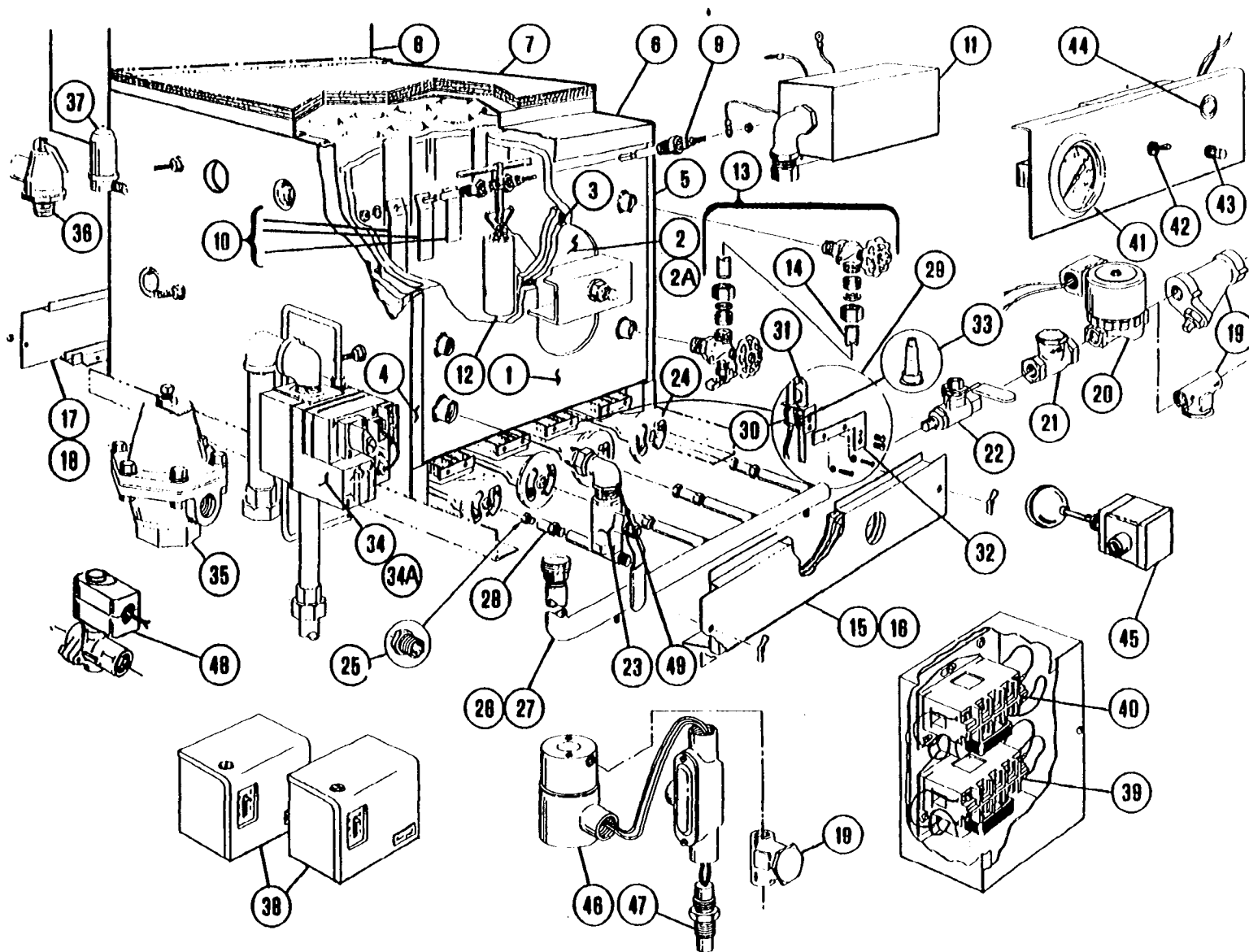

## GAS STEAM GENERATOR (BOILER) ASSEMBLY — 3 PROBE TYPE 160,000 BTU (3 BURNER) & 200,000 BTU (4 BURNER)

REFERENCE NUMBER	PART NUMBER	DESCRIPTION
1	43872	Boiler shell only with legs studs hand hole plate assembly and top flue bracket
	40298	Boiler shell 43872 above, also including two corrosion resistors, sight gauge, insulation panels, top flue collector with insulation and cover plate, three probes and extensions with cover box.
2	40421	Hand hole plate assembly including bar, nut and gasket
2A	43748	Hand hole plate only
3	07106	Hand hole gasket flat 4x6 oval.
4	43941	Left side insulating panel assembly
5	43943	Right side insulating panel assembly.
6	56320	Top flue collector.
7	40115	Top insulation baffle assembly (flat).
	40116	Top insulation baffle assembly (with flange).
8	42360	Internal flue riser assembly.
9	40462	Probe with lock washer and screw.
10	40455	Probe extension set (3).
11	52350	Probe cover.
12	43895	Corrosion resistor.
13	40445	Water gauge set with glass.
	07108	Fibre washer (2 required).
	23132	Gauge glass washer (2 required).
14	07302	Glass only — 6" long.
15	43851	3-burner front baffle assembly — Natural Gas.
	43855	3-burner front baffle assembly — LP. Gas.
16	43852	4-burner front baffle assembly — Natural Gas.
	43856	4-burner front baffle assembly — LP. Gas.
17	41365	3-burner rear burner support (after 7-76).
	69952	3-burner rear burner support (before 7-76).
18	41366	4-burner rear burner support (after 7-76).
	69953	4-burner rear burner support (before 7-76).
19	19870	1/4" fine strainer.
20	44095	1/2" water feed solenoid valve.
21	22102	1/4 check valve.
22	03276	1/4" ball valve — water supply shut-off.
23	03277	Generator drain valve — ball type.
24	02499	Main gas burner.
25	15453	Main burner orifice — Natural Gas.
	15450	Main burner orifice — LP. Gas-
26	40901	Gas manifold assembly — 3 burner (after 7-76).
	40905	Gas manifold assembly — 3 burner (before 7-76).
27	40902	Gas manifold assembly — 4 burner (after 7-76).
	40906	Gas manifold assembly — 4 burner (before 7-76)
28	19632	Orifice holder (after 7-76).
	19631	Orifice holder (before 7-76).
29	43651	Pilot generator assembly with 02505 burner. 20410 thermocouple. 52449 bracket and 15460 orifice.
	43653	Pilot generator assembly with 02523 burner. 20410 thermocouple. 52449 bracket and 15461 orifice.
30	20410	Pilot thermocouple.
31	02505	Pilot burner — Natural Gas.
	02523	Pilot burner — LP. Gas.
32	52449	Pilot bracket
33	15460	Pilot burner orifice — Natural Gas.
	15461	Pilot burner orifice — LP. Gas.
34	22182	1/2 combination gas control valve — Natural Gas.
34A	22096	1/2" combination gas control valve — LP Gas.
35	22122	3/4" pressure reducing valve. 3-15 psi output (optional).
36	22130	Safety valve — 8 psi.
	22131	Safety valve—15 psi.
37	22140	Air vent
38	19947	Pressure switch.
39	03514	Low water cut-off relay. 115 volt (1C1DO).
40	03504	Water control relay. 115 volt. (1D1DO).
41	07173	Steam pressure gauge, rear mount 0-30 psi.
42	19967	On-Off power switch. 115/220 volt 3 PDT.
43	19968	Reset switch.
44	12161	Signal light 115/220 volt
45	19945	Float switch with gasket — low water cut-off (California only).
46	22104	1/4" solenoid valve — boiler condenser water supply.
47	19979	Thermal switch — boiler condenser.
48	22106	Valve, solenoid. 1/2" boiler auto blowdown. 115 volt (optional).
49	05263	Radiator Ell. 3/4" union.

CLEVELAND RANGE CO., 1333 EAST 179th ST, CLEVELAND, OHIO 44110

**GAS STEAM GENERATOR (BOILER) ASSEMBLY — 3 PROBE TYPE**  
**250,000 BTU (5 BURNERS) ft 300,000 BTU (6 BURNERS)**

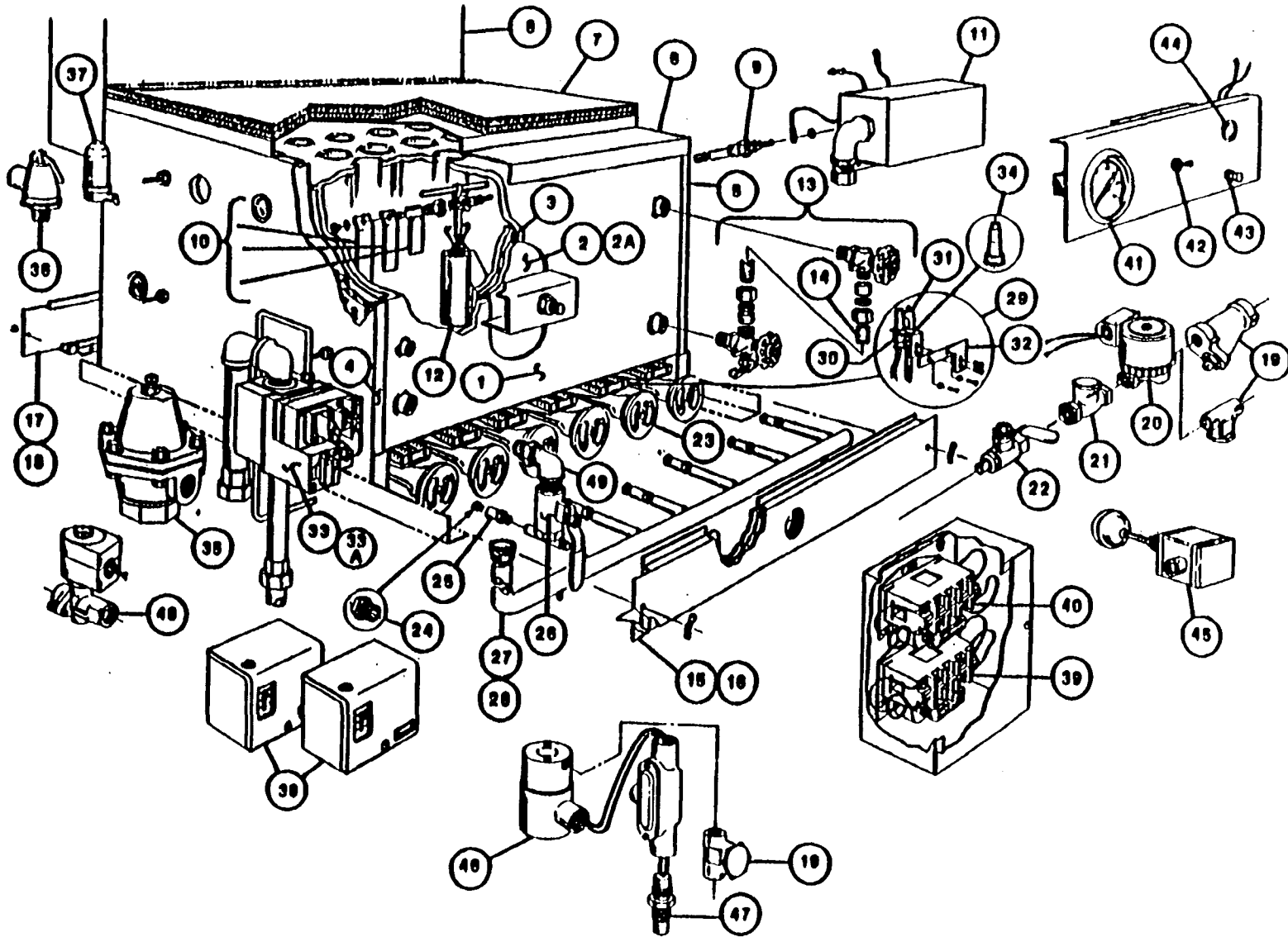

## GAS STEAM GENERATOR (BOILER) ASSEMBLY — 3 PROBE TYPE 250,000 BTU (5 BURNERS) & 300,000 BTU (6 BURNERS)

Reference NUMBER	PART NUMBER	DESCRIPTION
1	43873	Boiler shell only, with legs, studs, hand hole plate assembly and top flue bracket.
	40297	Boiler shell 43873 above, also including two corrosion resistors, sight gauge, insulation panels, top flue collector with insulation and cover plate three— probes and extensions with cow box.
2	40421	Hand Hole Plate Assembly including bar. nut and gasket
2A	43748	Hand hole plate only.
3	07106	Hand hole gasket flat 4x6 oval.
4	43942	Left side insulating panel assembly
5	43943	Right side insulating panel assembly
6	56321	Top flue collector
7	40117	Top insulation baffle assembly (flat)
	48118	Top insulation baffle assembly (with flange)
8	42361	Internal flue riser assembly
9	40462	Probe with lock washer and screw
10	40455	Probe extension set (3)
11	52350	Probe cover
12	43895	Corrosion resistor
13	40445	Water gauge set with glass
	07108	Fibre washer (2 required)
	23132	Gauge glass washer (2 required)
14	07302	Glass only -6" long
15	43853	5 burner front baffle assembly-Natural Gas
	43857	5 burner front baffle assembly-L.P. Gas
16	43854	6 burner front assembly-L.P Gas
		6 burner front assembly-L.P
17	41367	5 burner rear burner support (after 7-76)
		5 burner rear burner support (before 7-76)
18	41368	6 burner rear burner support (after 7-76)
	89955	6 burner rear burner support (before 7-76)
19	18870	1/4" line strainer
20	44095	1/2" water feed solenoid valve
21	22102	1/4" check valve
22	03276	1/4" ball valve-water supply shut off
23	02499	Main gas burner
24	15453	Main burner orifice-Natural Gas
	15450	Main burner orifice-LP Gas
25	19632	Orifice Holder (after 7-76)
	19631	Orifice Holder (before 7-76)
26	03277	Generator drain valve-ball type
27	40903	Gas manifold assembly-5 burner (after 7-76)
	40907	Gas manifold assembly-5 burner (before 7-76)
28	40804	Gas manifold assembly- 6 burner (after 7-76)
	40906	Gas manifold assembly- 6 burner (before 7-76)
2S	43652	Pilot generator assembly with 02505 burner, 20411 thermocouple and 52449 bracket
30	2011	Pilot thermocouple
31	02505	Pilot burner-Natural Gas
	02523	Pilot burner LP Gas
32	52449	Pilot bracket
33	22183	3/4 combination gas control valve-Natural Gas
33A	22189	3/4 combination gas control valve- LP Gas
34	15480	3/4 combination orifice- Natural Gas
	15481	3/4 combination orifice-LP Gas
35	22122	3/4 pressure reducing valve, 3-15 psi output (optional)
36	22130	Safety valve - 8 psi
	22131	Safety valve- 15 psi
37	22148	Air Vent
38	19947	Pressure switch
39	03514	Low water cutoff relay 115 volt (1C1DO)
40	03504	Water control relay, 115 volt (1D1DO)
41	07173	Steam pressure gauge, rear mount, 0-30 psi
42	1—87	On-Off power switch, 115/220 volt 3 PDT
43	19968	Reset switch
44	12161	Signal light, 115/220 volt
45	19945	Float switch with gasket-low water cut off (California only)
46	22104	1/4 solenoid valve-boiler condensor water supply
47	19979	Thermal switch-boiler condensor
48	22106	Valve solenoid 1/2" boiler auto blowdown, 115 volt (optional)
48	05263	Radiator Ell. 3/4 union



WIRING DIAGRAM FOR 100,000 and 150,000 BTU STEAM GENERATORS, WITH PILOT IGNITION,  
WITH AND WITHOUT SAFETY RESET CIRCUIT

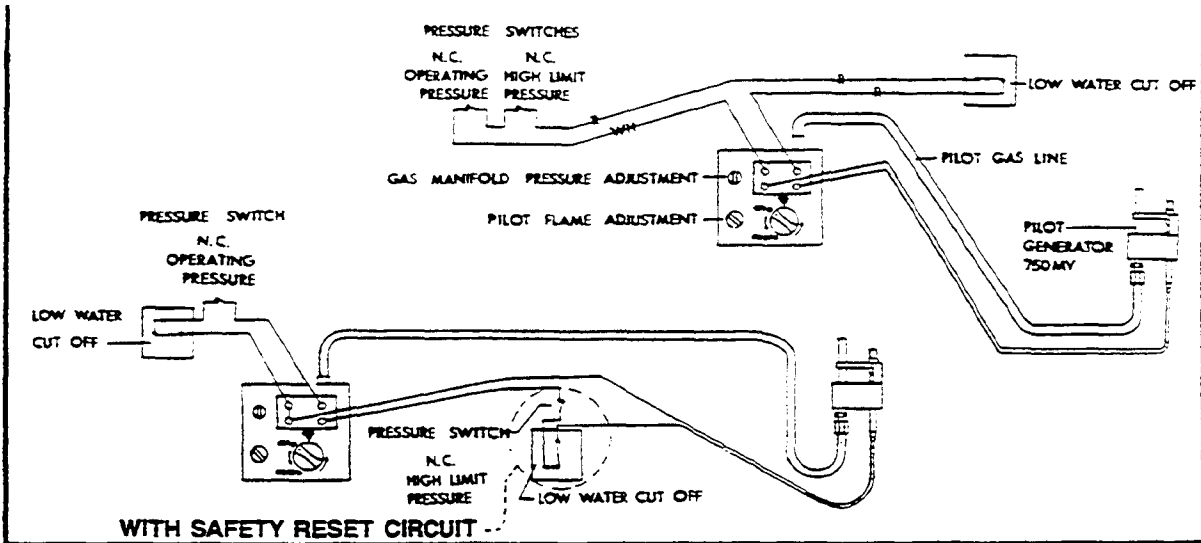

WIRING DIAGRAM FOR 210,000 BTU STEAM GENERATORS, WITH PILOT IGNITION,  
WITH MANUAL SAFETY RESET CIRCUIT

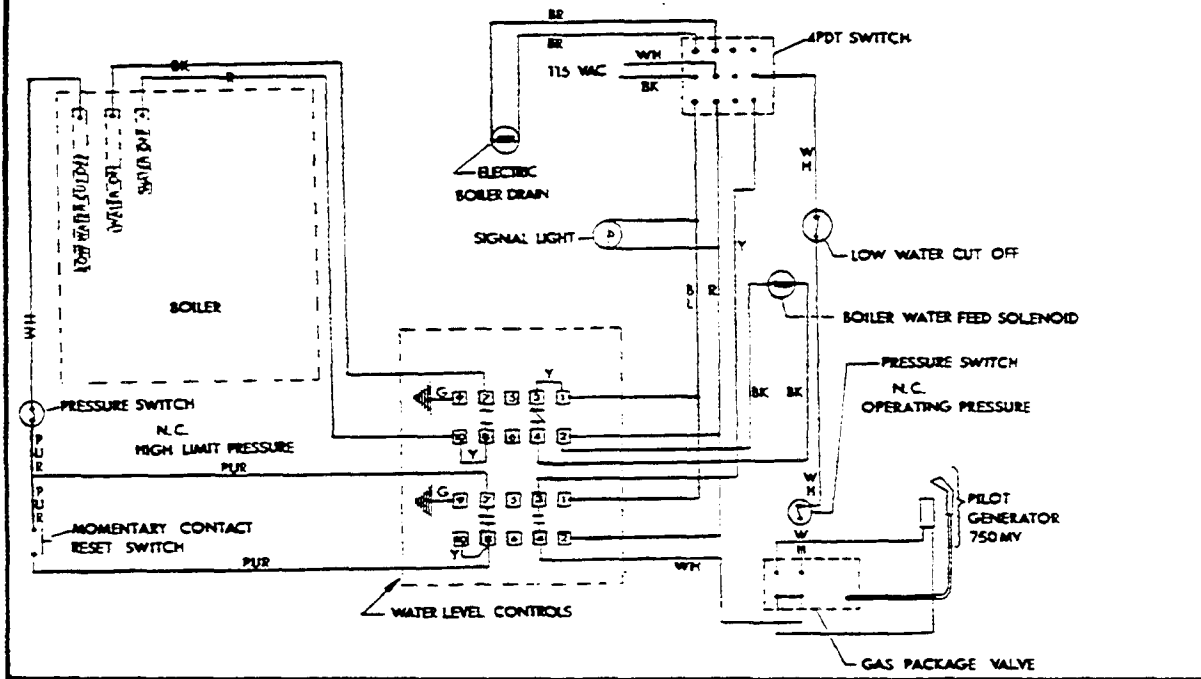

GAS	WATER	DRAINAGE	ELECTRIC CONTROL 115V	Wiring Diagram —Gas Fired— Steam Generators with Pilot Ignition (with 4 terminal gas valve, used prior to January, 1972).
½" FPT-AGA Model 150-M 150,000 BTU. ¾" FPT-AGA Model 210-M 210,000 BTU. Reduce input 4% per 1,000 ft. above 2,000 ft. altitude.	¾" Hot water boiler feed 35 PSI minimum 60 PSI maximum	¾" Boiler drain valve	Electric low water fuel shut- off and water supply, 25 watts for 210,000 BTU Steam Generator. (Does not apply to 100,000 and 150,000 BTU Steam Generators).	

WIRING DIAGRAM FOR 100,000 and 150,000 BTU STEAM GENERATORS, WITH PILOT IGNITION, WITH MECHANICAL LOW-WATER FUEL CUTOFF, WITH AND WITHOUT SAFETY RESET CIRCUIT

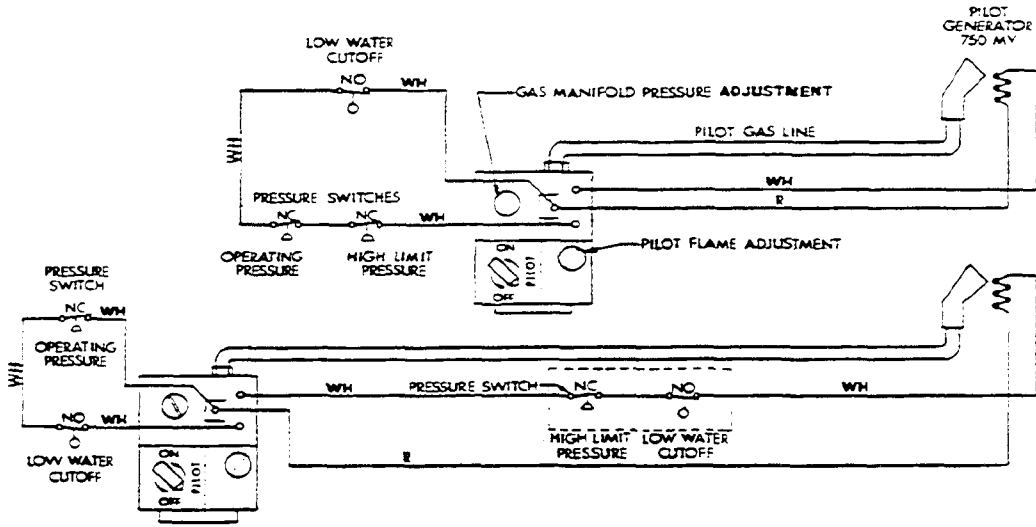

WITH SAFETY RESET CIRCUIT

WIRING DIAGRAM FOR 210,000 and 160,000/200,000 and 250,000/300,000 BTU STEAM GENERATORS, WITH PILOT IGNITION, WITH ELECTRICAL LOW-WATER FUEL CUTOFF, WITH MANUAL SAFETY RESET CIRCUIT

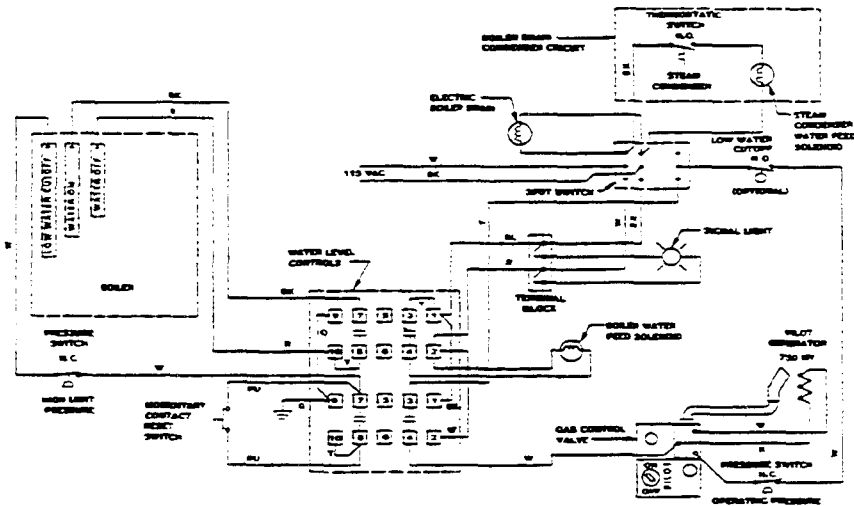

**GAS**

3/4" IPS for 220,000 BTU or less.  
 1" IPS for 240,000 BTU or more supply pressure.  
 W.C. min., 14" W.C. max. Manufacturer must be notified if unit will be used above 2,000 ft. altitude.

**WATER**

35 PSI minimum  
 60 PSI maximum  
 1/2" IPS hot water for steam generator  
 1/2" IPS cold water for condenser

**DRAINAGE**

1 1/2" IPS common drain  
 Do not connect any other units to this drain.

**ELECTRIC CONTROL 115V-1**

25 watts boiler control for electric low water fuel shut-off and water supply. (Does not apply to 100,000/150,000 BTU Steam Generators with mechanical low water fuel shut-off and water supply).

Wiring Diagram  
 —Gas Fired—  
 Steam Generators  
 with Pilot Ignition  
 (with 3 terminal gas valve, used after to January, 1972).

CLEVELAND RANGE, INC., 1333 EAST 179th ST., CLEVELAND, OHIO 44110  
 Manufacturer reserves right of design improvement or modification as warranted.

## STEAM COIL WIRING DIAGRAM

WIRING DIAGRAM FOR STEAM COIL GENERATORS  
WITH ELECTRICAL LOW-WATER SAFETY CUTOFF,  
WITH MANUAL SAFETY RESET CIRCUIT,  
3 PROBE TYPE, AFTER APRIL, 1984

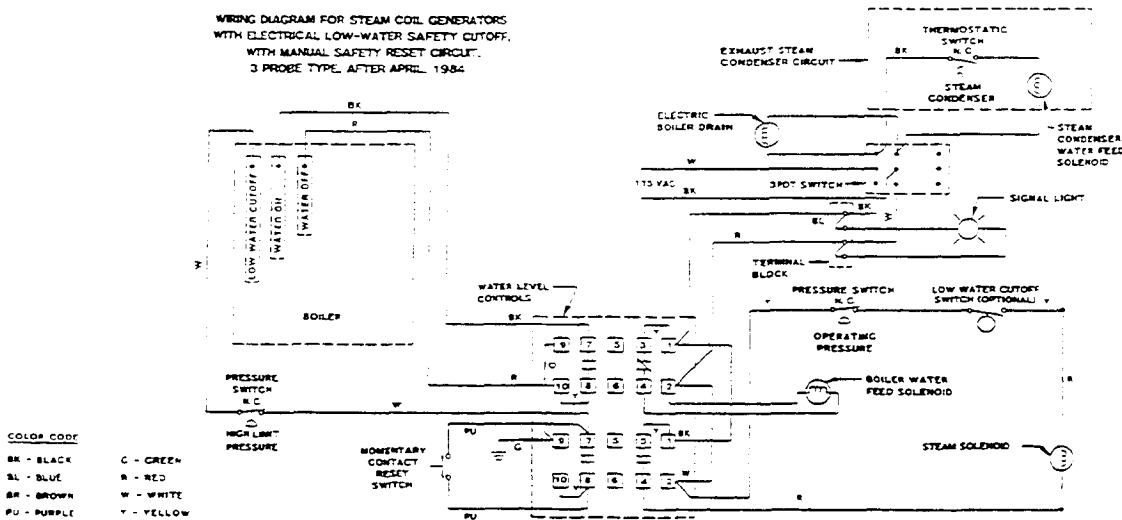

### HOW THE ELECTRICAL LOW WATER SAFETY SHUT-OFF OPERATES ON STEAM COIL (ELECTRIC OPERATED) STEAM GENERATORS

#### Operation — Low Water Safety Shut-Off

When Switch S is closed the following operations occur

1. The primary circuit of Transformer T is energized.
2. When the water level reaches the low water safety cutout probe extension and the momentary reset switch is manually closed. Relay Coil RC is energized.
3. When Relay Coil RC is energized, the normally open contacts close, completing the low water safety circuit through Contacts 7 and 8, and completing the circuit through Contacts 3 and 4, energizing Solenoid SV2, allowing steam to flow into the boiler's steam coil.

If the water level drops below the Low Water Safety Cutout probe extension, the following occurs:

1. The secondary circuit of Transformer T is broken and the Relay Coil RC is de-energized. Contacts 7 and 8 and 3 and 4 open, breaking the circuits to Solenoid SV2, thereby shutting off the flow of steam to the boiler's steam coil.

The steam Solenoid SV2 will not operate until water level in the boiler is normal and the reset switch is operated.

#### Operation — Boiler Drain Condenser

To activate the Boiler Drain Condenser System close Switch S by placing toggle in the down position.

To drain the boiler, open the boiler drain ball valve. The heat from the boiler drain water will close the normally open Thermal Switch TS and energize the condenser Solenoid Valve SV3. To deactivate the Boiler Drain Condenser System open Switch S by moving toggle to the center off position.

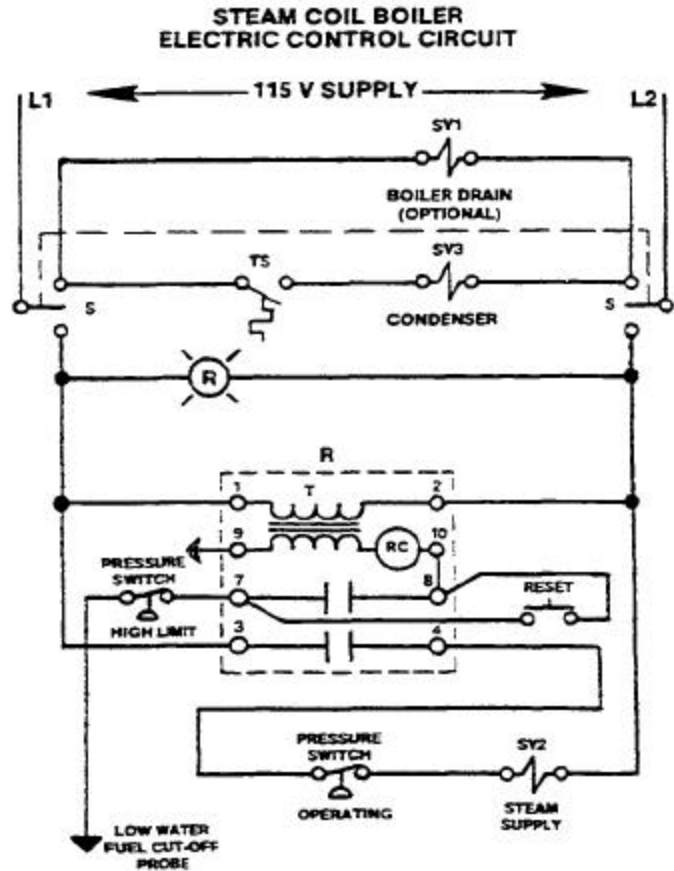

## SERVICING INSTRUCTIONS — MECHANICAL WATER FILL FOR STEAM GENERATOR

The water level in the sight gauge should normally be about 2/3 full. If it is not, then (1) the water valve may be scaled up or (2) the water valve plunger disc is in need of replacement or (3) the adjusting screw at the top of the valve plunger is set incorrectly or (4) the float needs to be replaced.

**WARNING: Steam under pressure may cause serious injury and bodily harm when it is accidentally or carelessly released. Therefore, service of the steam generator should only be performed by trained and experienced personnel, thoroughly familiar with servicing steam generators.**

To service the water valve:

1. Turn off all utilities and fuel to steam generator. Drain steam generator.

**CAUTION: Never work on the steam generator while it is hot or pressurized.**

2. Remove hand hole plate from steam generator. Refer to separate data sheet for proper procedures and cautions.
3. (Inside the steam generator as shown on the diagram). Remove the float arm pivot screw. Disengage float arm assembly.
4. Lift out valve plunger disc and install new plunger disc.
5. Remove scale from valve seat and other internal valve surfaces.
6. Re-insert plunger in valve.
7. Install float arm assembly and check the adjustment. Float travel should be approximately 6 inches.
8. To increase the travel, turn adjusting screw clockwise. To decrease, reverse.
9. Re-install hand hole plate, never applying more than 15 ft./lbs- torque to the nut. The hand hole plate should be cleaned and examined every time it is removed. If the hand hole plate is chipped or cracked, or over three years old, install a new one. Because continuous use and possible abuse cause metal fatigue which weakens the hand hole plate, a new one should be installed at least every three years- Replace the gasket at least once a year — or sooner if it is cracked or hardened. Replace the hand hole gasket when re-installing the hand hole plate.

10. Close steam generator drain valve. Turn on utilities and fuel.
11. Check **the water level**. Proper level in the sight gauge is about 2/3 full.

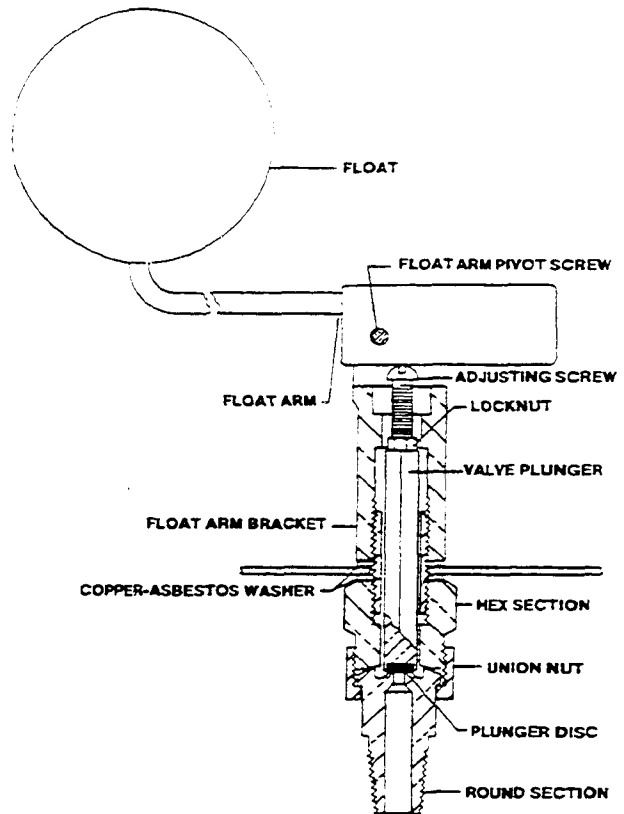

12. Start up and observe steam generator long enough to see that it is operating properly.
  13. After the valve plunger disc is installed, order more to have spares on hand at all times.
- If hard water scale created the problem, the use of more corrosion resistors or more frequent replacement of them is required. Refer to separate data sheets for maintenance instructions pertaining to scale problems.

**STEAM COIL GENERATOR (BOILER) ASSEMBLY WITH VARIOUS CONTROL OPTIONS (INCLUDES BOILERS EQUIPPED WITH 0, 1, or 3 PROBES)**

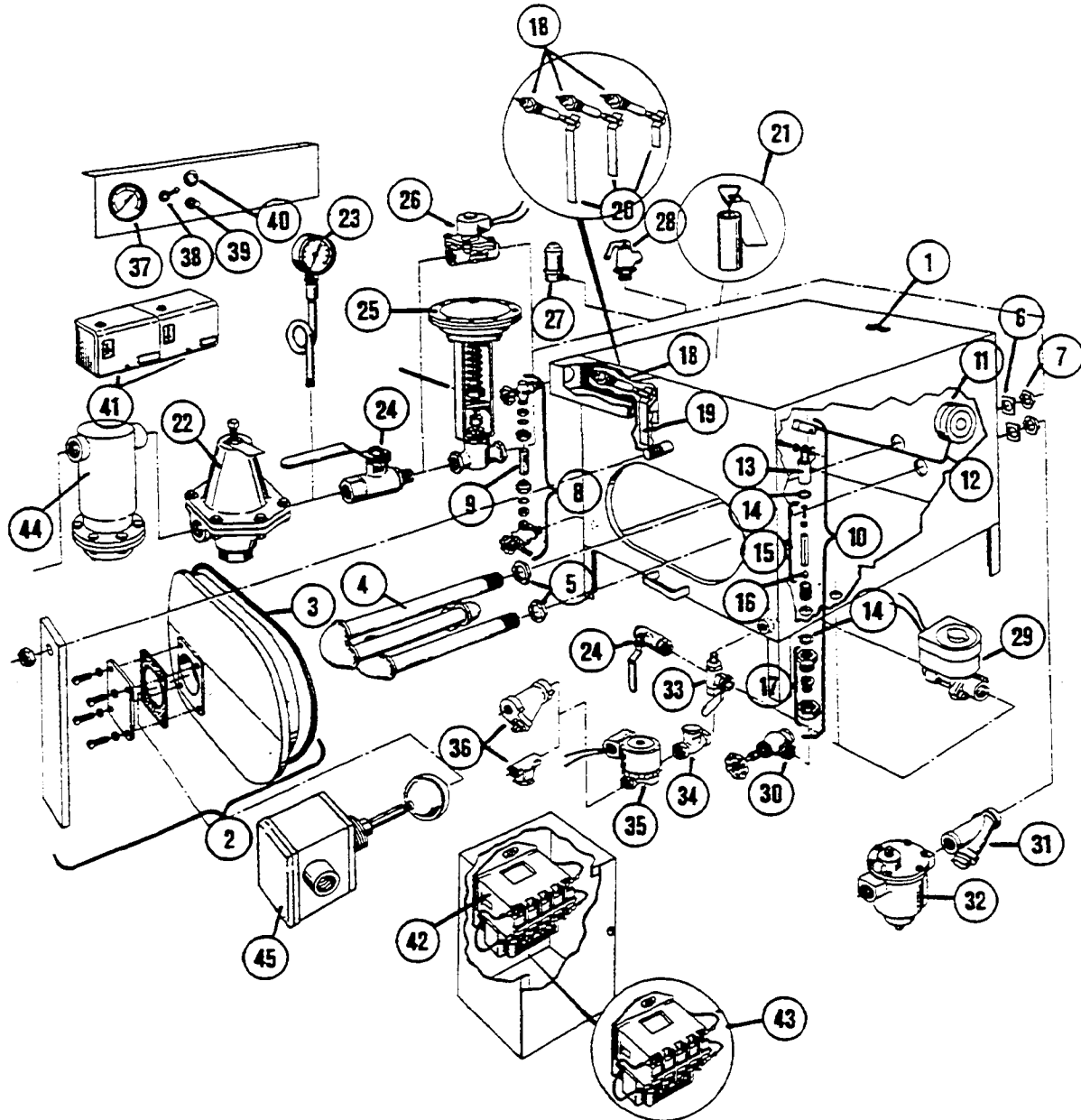

CLEVELAND/ALCO, 1333 EAST 179th ST., CLEVELAND, OHIO 44110  
Manufacturer reserves right of design improvement or modification, as warranted.

## STEAM COIL GENERATOR (BOILER) ASSEMBLY WITH VARIOUS CONTROL OPTIONS (INCLUDES BOILERS EQUIPPED WITH 0, 1, or 3 PROBES)

REFERENCE NUMBER	PART NUMBER	DESCRIPTION	REFERENCE NUMBER	PART NUMBER	DESCRIPTION
	43700	Steam coil boiler shell with legs. <i>sight gauge</i> . water regulator. steam coil. one corrosion resistor. hand hole plate assembly. (For use with mechanical pressure regulating valve tor controlling the steam supply.)	19	62453*	Probe extension (tor use only with single probe boilers)
	43782	Steam coil boiler shell (43700) above, also in cluding one probe and extension with cover box, tor electric operation of the steam supply con trols (solenoid valve in lieu of the mechanical pressure regulating valve).	20	101468	Probe extension set (3) (for use only with three probe boilers)
	439881	Steam coil boiler shell only. with legs and hand note plate assembly. (Equipped with 3 probe holes, for use with electrically controlled water and steam supplies).	2-	43895	Corrosion resistor (no: used with 3 probe boilers)
	43989	Steam coil boiler shell (43988) above, also including sight gauge, steam coil. 3 probes and extensions with cover box (for use with electrically controlled water ana steam supplies).	22	22200	3/4" Pressure reducing valve - 30 to 50 psi (optional)
2	100636	Hand note plate assembly, incl. bar. nut. ana gasket	23	07169	Pressure gauge, bottom mount 0-100-psi)
	16545	Hand hole plate only	24	03277	3/4- Ball valve
3	07116	Hand hole gasket	25	22151	3/4" Steam control valve
4	40401	Steam coil assembly	26	22193-	3/4 " Steam solenoid valve
5	14612	1 1/4 Brass locknut	27	22140	Air vent
6	23135	3% " Square flat washer	28	100075	Safety valve - 50 psi
7	14611	T'A " Steel tocknut	29	22106	1/2 Solenoid valve, boiler auto blowdown, 115 volt (optional)
8	40446	Water gauge set with glass	30	22112	Water shut-off! angle valve
	07106	Rbre Washer (2 required)	31	19872	3/4" Line strainer
	23132	Gauge Glass Washer (2 required)	32	20555	3/4 Bucket trap
9	07301	Glass only -10%" tong	33	03276	1/4" Ball valve
10	43720	Water regulator valve assembly (used before April. 1984)	34	22102	1/4" Check valve
11	06300	Float only	35	44095-	1/2" Water teed solenoid valve
12	43740	Float arm and block assembly	36	19870	1/4. " Line strainer
13	100655	Float pivot bractet	37	07173	Pressure gauge, rear mount. 0-30 psi. 2 1/2"
14	23130	Sealing washer		07168	Pressure gauge, rear mount. 030 psi. 2' (Pressure Steamers only)
15	43735	Float plunger assembly	38	19944*-	On - off power switch. 115/220 volt. DPST
16	16833	Plunge- disc	39	19968*-	Reset switch
17	43724	Water regulator valve sub-assembly (seat)	40	12161*	Signal light. 115/220 volt 1-
18	40462	Probe with lockwasher and screw		12169*-	Signal light. 115/220 volt, 1/2' (Pressure Steamers only)
			41	19947-	Pressure switch
			42	03514-	Low water cut-off relay. 115 volt (1C1DO)
			43	03504"	Water control relay. 115 volt (1D1DO)
			44	19020***	3/4" Moisture separator (ball float trap)
			45	19945*-	Float switch with gasket - low water cut-off (California only)

\*Required for electric steam control and electric low water cut-off safety circuit Through November 1982, these components were used in lieu of the #22151 steam control valve as standard equipment on all 24" and 60" wide cabinets and all California units, but optional on 36" and 42" wide cabinets. After November 1982, the #22151 was **not** used and the electric controls became standard equipment on all steam coil generators.

\*\*Required for electric (solenoid valve) water fill, used in lieu of the #43720 water regulator valve, beginning April 1984.

\*\*\*Optional, if steam supply is wet.