

U.S. Range

Installation & Operation Instructions for ***SunFire*** Series Gas Restaurant Ranges

FOR YOUR SAFETY

DO NOT STORE OR USE GASOLINE OR OTHER FLAMMABLE VAPORS OR LIQUIDS IN THE VICINITY OF THIS OR ANY OTHER APPLIANCE.

WARNING:

IMPROPER INSTALLATION, ADJUSTMENT, ALTERATION, SERVICE OR MAINTENANCE CAN CAUSE PROPERTY DAMAGE, INJURY OR DEATH. READ THE INSTALLATION, OPERATING AND MAINTENANCE INSTRUCTIONS THOROUGHLY BEFORE INSTALLING OR SERVICING THIS EQUIPMENT

PLEASE READ ALL SECTIONS OF THIS MANUAL AND RETAIN FOR FUTURE REFERENCE.

THIS PRODUCT HAS BEEN CERTIFIED AS COMMERCIAL COOKING EQUIPMENT AND MUST BE INSTALLED BY PROFESSIONAL PERSONNEL AS SPECIFIED.

THIS EQUIPMENT IS NOT RECOMMENDED FOR RESIDENTIAL INSTALLATION.

WE SUGGEST INSTALLATION, MAINTENANCE AND REPAIRS SHOULD BE PERFORMED BY YOUR LOCAL MAINTENANCE AND REPAIR CENTER, LISTED IN YOUR INFORMATION MANUAL PAMPHLET.

NOTE: All SunFire ranges must be installed with no less than six inches (6") clearance from combustible construction at the rear and no less than nine inches (9") clearance from combustible construction at each side. SunFire ranges are suitable for installation on combustible floors.

FOR YOUR SAFETY: Post in a prominent location, instructions to be followed in the event the user smells gas. This information shall be obtained by consulting your local gas supplier.

Continuous product improvement is a U.S. Range policy, therefore design and specifications are subject to change without notice.

In the event you have questions about the installation, use, care or service of this product, contact our customer service department at:



 **U.S. Range**

185 East South Street
Freeland, Pennsylvania 18224
Phone: (717) 636-1000
Fax: (717) 636-3903

Contents

Models & Input Ratings	3
Individual Burner Input Ratings	3
Pre-Installation Notes	4
Assembly	4
Appliances Equipped with Casters	4
Appliances Equipped with Legs	4
Installation	5
Gas Connection	5
Electrical Connection, (models with suffix “CP”)	5
Ventilation & Air Supply	6
Installing a Backguard or Shelf	6
Testing & Adjustment	7
Griddle Break-in	6
Griddle Seasoning	6
Operation	8
Open Top Burners	8
Hot Top Sections	8
Thermostat Controlled Griddles	8
Valve Controlled Griddles	9
Raised Broiler/Griddles	9
Standard Ovens	9
General	10
Open Burners	10
Hot Tops	10
Convection Ovens	11
Product Application Information	11
Griddles	13
Convection Ovens	13
Care & Cleaning	13
Painted Finish	13
Stainless Steel	13
Oven Interior, (porcelain enamel)	13
Oven Interior	14
(optional continuous clean)	14
Open Top Burners	14
Cast Iron Top & Ring Grates	15
Griddle	15
Hot Tops	15

Models & Input Ratings

Model No.	Configuration	Total BTU's
S-4	(4) open burners, storage base	88,000
S-4-20	(4) open burners, (1) 20" oven	113,000
S-6	(6) open burners, storage base	132,000
S-6-26	(6) open burners, (1) 26" oven	162,000
S-6-26CP	(6) open burners, (1) 26" convection oven	162,000
S-6-24BG-2626	(6) open burners, (1) 24" raised broiler/griddle, (2) 26" ovens	234,000
S-6-24BG-2626CP	(6) open burners, (1) 24" raised broiler/griddle, (1) 26" oven, (1) 26" convection oven	234,000
S-6-24BG-26CP26CP	(6) open burners, (1) 24" raised broiler/griddle, (2) 26" convection ovens	234,000
S-6-24BG-26	(6) open burners, (1) 24" raised broiler/griddle, (1) 26" oven (1) storage base	204,000
S-6-24BG-26CP	(6) open burners, (1) 24" raised broiler/griddle, (1) 26" convection oven (1) storage base	204,000
S-10	(10) open burners, storage base	220,000
S-10-2626	(10) open burners, (2) 26" ovens	280,000
S-10-2626CP	(10) open burners, (1) 26" oven, (1) 26" convection oven	280,000
S-10-26CP26CP	(10) open burners, (2) 26" convection ovens	280,000
S-10-26	(10) open burners, (1) 26" oven (1) storage base	250,000
S-10-26CP	(10) open burners, (1) 26" convection oven (1) storage base	250,000

Individual Burner Input Ratings

Burner	BTU's
Open Burner	22,000
Hot Top, (in lieu of two open burners)	24,000
12" Griddle, (in lieu of two open burners)	24,000
Broiler/Griddle	14,000
26" Oven Burner, (standard & convection)	30,000
20" Oven Burner	25,000

Pre-Installation Notes

1. Damage check: Check carton or crate for possible damage incurred in shipping. After carefully uncrating, check for “concealed” damage. Report any damage immediately to your carrier.
2. The correct type of gas for which the unit was manufactured is noted on the rating plate, and only this type of gas must be used. Confirm that the range is equipped for the type of gas you intend to supply.
3. Plan the installation to allow adequate clearance for proper operation and service.

Assembly

Appliances Equipped with Casters

1. The installation shall be made with a connector that complies with the Standard for Connectors for Moveable Gas Appliances, ANSI Z21.69, (or latest edition), addenda Z21.69a-1989, and a quick-disconnect device that complies with the Standard for Quick Disconnects for Use with Gas Fuel, ANSI Z21.41, (latest edition).
2. The front casters on the appliance are equipped with brakes to limit the movement of the appliance without placing any strain on the connector or quick disconnect device or its associated piping.
3. Please be aware; required restraint is attached to a bracket, (which is located on the rear caster closest to the gas connection), and if disconnection of the restraint is necessary, be sure to reconnect the device after the appliance has been returned to its original position.

Appliances Equipped with Legs

Raise the front of the appliance and block. Do not lay the appliance on its back. Position a leg insert in leg retainer opening and tap upward until the insert seats at the collar flange. Repeat leg insert installation for

the other three legs and adjust all four legs to the same height. Legs can be further adjusted to level the appliance and to compensate for uneven flooring.

The installation shall be made with a connector that complies with the Standard for Connectors for Movable Gas Appliances, ANSI Z21.69, or Connectors for Movable Gas Appliances, CAN/CGA-6.16, and a quick disconnect device that complies with the Standard for Quick-Disconnect Devices for Use With Gas Fuel, ANSI Z21.41, or Quick-Disconnect Devices for Use With Gas Fuel, CAN1-6.9.

Installation

Gas Connection

1. The type of gas for which the unit is equipped is stamped on the rating plate, (refer to 'SERIAL PLATE LOCATION,' page 2). Connect a unit stamped "NAT" only to natural gas, and a unit stamped "PRO" only to propane.
2. In a new installation, have the gas authorities check meter size and piping to ensure that the gas supply will deliver sufficient pressure to operate the unit properly.
3. When adding or replacing equipment, have gas authorities check gas pressure to ensure that the existing meter and piping will supply fuel to the appliance with no more than 1/2 inch water column pressure drop during operation.
4. The gas pressure must be checked when the unit is installed to ensure that the operating gas pressure is the same as that specified on the rating plate. If necessary, pressure adjustments may be made at the pressure regulator, supplied on each appliance.
5. Have a qualified gas technician check the gas pressure to make certain that the existing gas facilities, (meter, piping, etc.), will deliver the volume, (BTU's), of gas required for proper operation with no more than .50" water column pressure drop. When checking pressure, be sure that all the equipment on the same gas line is turned to the "ON" position.
6. Make certain that new piping, joints and connections have been made in a clean manner, and have been purged, so that the piping compound, chips, etc., will not clog pilots, valves, and/or controls. Use pipe joint sealant that is approved for use with natural and liquefied petroleum gases.
7. **WARNING:** Check gas connections for leaks using soap solutions or similar means. **DO NOT CHECK WITH AN OPEN FLAME.**
8. The appliance and its individual shut-off (supplied by others) must be disconnected from the gas supply piping system during any pressure testing of that system at pressures in excess of 1/2 PSIG (3.45 KPA).

The appliance must be isolated from the gas supply piping by closing its individual manual shut-off (supplied by others) during any pressure testing of the gas supply piping system at test pressures equal to or less than 1/2 PSIG (3.45 KPA).

The installation must conform with local codes, or in the absence of local codes, with the National Fuel Gas Code, ANSI Z223.1, Natural Gas Installation Code, CAN/CGA-B149.1, or the Propane Installation Code, CAN/CGA-B149.2, as applicable.

Electrical Connection

(models with suffix "CP")

IMPORTANT - This appliance must be electrically grounded in accordance with local codes, or, in the absence of local codes, with the National Electrical Code.

Permanent connection to the electrical service must comply with local codes, or in the absence of local codes, with the national Electrical Code.

A wiring diagram is attached to the rear of each appliance.

WARNING: Electrical Grounding Instructions. This appliance is equipped with a three pronged (grounding) plug for your protection against shock hazard and should be plugged directly into a properly grounded three-pronged receptacle. Do not cut or remove the grounding prong from this plug.

POWER FAILURE NOTE: In the event of a power failure, no attempt should be made to operate this oven. This oven is gas operated but has electrical features, motor and door switches.

Installation, (continued)

Ventilation & Air Supply

Proper ventilation is highly essential for optimum performance. The ideal method of ventilating open-top equipment is the use of a properly designed canopy which should extend six inches, (152mm), beyond all sides of the appliance(s) and six feet, six inches, (1981mm), above the floor.

A strong exhaust will create a vacuum in the room. For an exhaust vent to work properly, replacement air

must enter the room. The amount of air that enters must equal the amount exhausted.

All gas burners and pilots need sufficient air to operate. Large objects should not be placed in front of the appliance(s) which would obstruct the flow of air into the front.

Installing a Backguard or Shelf

1. Rear of range must be easily accessible.
2. Remove the flat-head bolt "A" from each side of the backguard only when the unit will be placed against another appliance with a backguard, shelf, or broiler.
3. Place the backguard, high shelf, salamander, or cheesemelter on the rear of the range, slipping the support brackets into the openings in the burner box sides.
4. Securely fasten the support brackets to the burner box sides with (4) 1/4-20 x 3/4 slot truss head machine screws, or (4) #10B x 1/2 Phillips sheet metal screws. (Hardware package is supplied).
5. Remove front panel.
6. If the appliance is banked with others that have backguards installed, replace the flat head bolts removed in Step B so that the upright of the

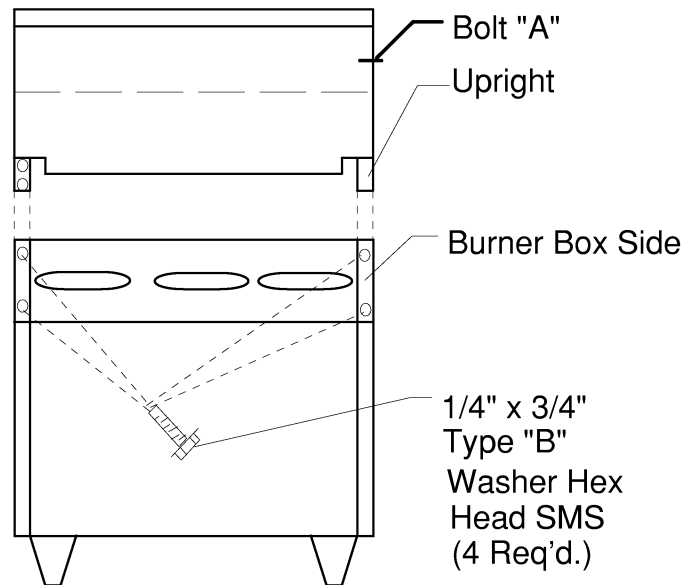

backguard is fastened to upright of the adjacent backguard.

7. Replace the front panel(s).

Testing & Adjustement

All fittings and pipe connections must be tested for leaks. Use approved gas leak detectors, soap solution or equivalent, checking over and around all the fittings and pipe connections. **DO NOT USE A FLAME!** Accessibility to all gas lines and fittings require that valve panel(s), lower front panel(s), and/or oven rack(s) be removed. It may be necessary to remove, or at least raise and securely prop griddle(s), hot top(s), and/or top grate(s). All parts removed, (including fasteners), should be stored safely for re-installation.

1. Be sure that all valves and thermostats are in the "OFF" position.
2. Turn on the main gas supply valve. Light all top section pilots.
3. Leak test all valves and fittings as described at the beginning of this section. Correct any leaks as required and recheck.

4. Light the oven pilot.
5. If the range is equipped with an oven on/off valve separate from the thermostat, turn this valve on. If the oven thermostat dial has an "OFF" position, the thermostat is its own on/off valve.

In either case, now set the thermostat to 500° F, (260° C).

6. Leak test all valves and fittings as described at the beginning of this section. Correct any leaks as required and recheck.
7. Shut off all valves and set thermostat dials to "OFF" or lowest position.

All units are tested and adjusted at the factory, however, burners and pilots should be checked upon installation and adjusted if necessary.

Caution: Gas will flow to the top section burners even if top section pilots are not lit. Gas will not be interrupted. It is the responsibility of the operator to confirm the proper ignition of each burner as it is turned on. Should ignition fail to occur 5 seconds after turning a burner on, turn the burner off, wait 5 minutes, and try again.

Griddle Break-in

Griddle Seasoning

1. Remove all factory applied protective material by washing with hot water, mild detergent or soap solution.
2. Apply a thin coat of cooking oil to the griddle surface, about one ounce per square foot of griddle surface. Spread over the entire griddle surface with a cloth to create a thin film. Wipe off any excess oil with a cloth.
3. Light all burners, set a lowest possible setting. Some discoloration will occur when heat is applied to steel.
4. Heat the griddle slowly for 15 to 20 minutes. Then wipe away oil. Repeat the procedure 2 to 3 times until the griddle has a slick, mirror like finish. Do

this until you have reached the desired cooking temperature.

IMPORTANT: Do not attain high (on valve control) or 450°(on thermostat control) during "break-in" period.

NOTE: Steel griddle surface will tone (blue discoloration) from heat. This toning will not diminish function or operation and is not a defect.

The griddle will not require reseasoning if it is used properly. If the griddle is over heated and product begins to stick to the surface it may be necessary to repeat the seasoning process again. If the griddle is cleaned with soap and water it will be necessary to reseason the griddle surface.

Operation

Open Top Burners

Lighting:

1. Light pilots located in the center of each burner.
2. Turn valve completely on. Burner flame should be 1/2-inch, (13mm), stable blue flame, and should impinge on the bottom of a pot placed on the ring grate.

Shut Down:

1. Turn all valves to the “OFF” position.
2. If the unit is to be shut down for an extended period of time, close the in-line gas valve.

CAUTION: Should burner ignition fail within 5 seconds, turn the burner valve off and repeat steps 1 through 5. If ignition continues to fail, consult your factory authorized service agency.

Hot Top Sections

1. Raise or remove hot top sections. Each burner has one pilot located at the front right side of the burner.
2. Light pilots. The pilot burner should be adjusted to provide for rapid ignition of the burner.
3. Turn the burner valve on. A sharp blue flame should be approximately 1/4-inch, (6mm), high.
4. Replace hot top sections.

Thermostat Controlled Griddles

1. Raise griddle at front and securely block.
2. Light pilots located at the front right side of each burner.
3. The sensing bulbs must be fully inserted into their individual holders, which are located on the underside of the griddle.
4. Set the thermostat to its maximum setting. The burner should have a 5/16-inch, (8mm), stable blue flame.
5. Lower the griddle carefully into position, being very careful not to leave any part of the capillary tube in the burner compartment.

Valve Controlled Griddles

1. Raise griddle at front and securely block.
2. Light pilots located at the front right side of each burner.
3. Turn burner valves completely on. Burners should have 1/2-inch to 5/8-inch, (13mm to 16mm), stable blue flame.
4. Lower griddle carefully into position.

Raised Broiler/Griddles

1. Light the pilots located in the broiler section.
2. Turn the burner valves completely on. Burners should exhibit a 5/16-inch stable blue flame.

Caution: Gas will flow to the top section burners even if top section pilots are not lit. Gas will not be interrupted. It is the responsibility of the operator to confirm the proper ignition of each burner as it is turned on. Should ignition fail to occur 5 seconds after turning a burner on, turn the burner off, wait 5 minutes, and try again.

Standard Ovens

Lighting:

1. Remove oven bottom(s).
2. Depress and hold the red reset button, located at the lower front of the oven, (beneath the oven door), while lighting the oven pilot. Continue to hold the reset button for at least 60 seconds after the pilot is lit. Release the button. If the pilot does not stay lit, wait five, (5), minutes, then repeat the procedure.

Shut Down:

1. Turn all valves and thermostats to the "OFF" position, or lowest setting.
2. If the range is to be shut down for an extended period of time, close the in-line gas valve.

Relighting:

1. Turn all gas valves off.
2. Wait five, (5), minutes.
3. Follow procedure under "LIGHTING" at left.

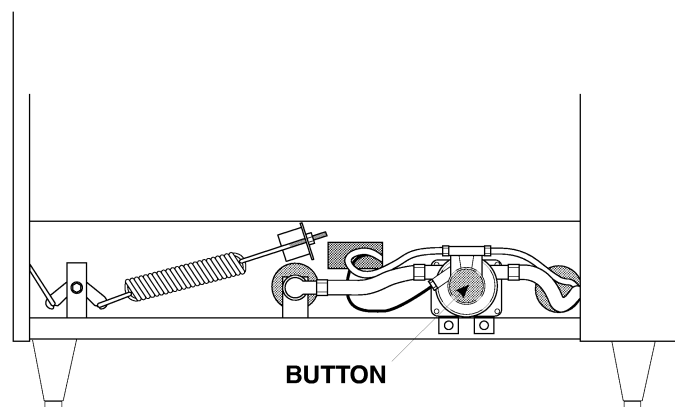

Operation, (continued)

Convection Ovens

Lighting:

1. Using the access through the louver panel hold the reset button (RED) located on the oven safety valve. (See prior)
2. Using the access hole located below the louver in the panel, push the RED IGNITOR BUTTON continuously until the oven pilot ignites. (See prior)
3. If the pilot does not stay lit after you release the reset button, wait 5 minutes and repeat Step 2 and hold the reset button approximately 60 seconds.

Start Up

1. Activate the power switch to cook position.
2. Turn oven valve on.
3. Turn thermostat to desired setting.

Cool Down

1. Turn thermostat and oven valve off.
2. Open door.
3. Activate power to the cool down position

The motor on your range convection oven is maintenance free since it is constructed with self-lubricating sealed ball bearings. It is designed to provide durable service when treated with ordinary care. We have a few suggestions to follow on the care of your motor.

- A. When the motor is operating, it cools itself internally by air entering the rear of the motor case, provided proper clearance has been allowed.
- B. Since the blower wheel is in the oven cavity it is at the same temperature as the oven. If the motor is stopped while the oven is hot, the heat from the blower wheel is conducted down the shaft and into the armature of the motor. This action could shorten motor life.
- C. We recommend, at the end of the bake or roasting period, when the oven will be idle for any period of time or before shutting down completely, that the doors be left open, and by use of the cool-down position on the fan switch, the fan continues to run for at least 20 minutes. The "FAN" should never be turned "OFF" when the oven is "HOT".

Product Application Information

General

The range is the workhorse of the kitchen because of its versatility. Most frequently used in small applications, such as cafes, schools, church kitchens, firehouses, and small nursing homes where demands are less taxing. As a general rule of thumb, one four to six burner range with a hot top will be adequate for a restaurant seating 30 to 35.

The top of the range is designed for flexibility and the preparation of numerous different types of products. It may be equipped with two, or even three different types of tops and burners, depending on the menu needs. An operation that cooks to order, or uses the range primarily as back-up will find that open burners will suit most of their needs.

Preparation of soups, stocks, or sauces is done on a hot top where slow, even cooking is desirable.

Heating larger quantities of food can be done more efficiently than heating small quantities. Pots and pans should be covered whenever possible to reduce energy consumption.

High acid sauces, such as tomato should be cooked in stainless steel rather than aluminum to avoid chemical reaction. Light colored sauces such as Alfredo may be discolored by the use of aluminum, especially if stirred with a metal spoon or whip. Saltwater shellfish may pit aluminum pots if they are frequently used for this purpose.

NOTE: Many parts of the commercial range are raw steel. Hot tops, griddles, springs, door hooks, etc., can react with moisture, forming rust. This occurrence is normal and not considered a defect. Clean with a stainless steel or fiber pad. A light coating of cooking oil may be applied.

Open Burners

The most traditional uses of open burners are sautéing, pan frying, and small stock pot work. Short-term cooking is the most efficient use for the open burner. Pans should cover as much of the grate as possible to minimize heat loss. The maximum stock

pot size to be used on an open burner is 11 inches, (279mm), diameter. Open burners should be turned off when not in use to conserve energy. Leaving a flame burning is of no advantage since the heat is instantaneous.

Hot Tops

Hot tops are recommended where long-term stock pot cooking is required for soups, sauces or stocks. Pots can be placed anywhere on the hot top, rather than in one specific position, as on an open burner. The maximum stock pot size to be used on the hot top is 12 inches, (305mm), in diameter.

Recommended preheat time for a 12-inch, (305mm), hot top section is 30 minutes. This will thoroughly saturate the metal with heat. Hot tops are evenly heated, and have a smooth surface so that pots may be moved

easily to any position. Pots must have a flat bottom for maximum contact with the hot top surface. Warped or dented pots will not transfer heat evenly or efficiently, wasting energy and resulting in uneven cooking patterns. Roasting pans with straps should not be used on a hot top because only the straps will touch the heated surface and transfer will be minimal. During slow times, group pots on one hot top section and turn off the other section(s). This will conserve energy. If needed, the other section(s) will preheat in 10 to 15 minutes due to the retained heat in the metal.

Product Application Information, *(continued)*

Griddles

Griddle tops are designed to have food cooked directly on the surface, for example hamburgers, eggs, pancakes, hash browns, etc. Do not put pots or pans on the griddle surface. This will scratch or nick the surface, resulting in sticking and scorching of product. Never salt food on a griddle because this will cause a gummy residue to build up, making the griddle more difficult to clean. Avoid hitting the griddle plate with a

spatula, as this will also nick the surface. The most frequently used temperature range for griddles is 325° to 350° F, (163° to 177° C). Check and drain the grease drawer frequently during heavy use to prevent overflowing. Over a period of time, some discoloration of the steel griddle plate will occur. This will not affect performance. For best cooking results, keep the griddle surface as clean and shiny as possible.

Convection Ovens

Generally, a temperature 25° to 50° F, (-4° to 10° C), lower than that specified in recipes for standard ovens should be used. Cooking time may be reduced, depending on the product. A 2% to 5% reduction in cook time is a general rule. Keep a close check on any product being prepared for the first time. The size of the load, temperature of the product going in, and moisture content are the major factors that influence necessary cook times and temperatures. Successfully prepared products should be recorded with their times and temperatures for future reference.

Preheat the oven thoroughly before loading. It will take approximately 15 minutes for the oven to reach 350° F, (177° C). Best results will be attained when the oven is allowed to preheat for 30 minutes or more for thorough heat saturation.

Center the load on the oven racks to allow for proper heat circulation around the sides. The oven will hold three, (3), 18" x 26", (457mm x 660mm), sheet pans, six, (6), 12" x 20" x 2.5", (305mm x 508mm x 64mm), steam table pans, or one, (1), 17.75" x 25.75", (451mm

x 654mm), roast pan. Never place pans directly on the oven bottom. Always use the lowest rack position that will allow the heated air to circulate within the oven cavity. Load and unload food as quickly as possible to prevent excessive temperature drop. For even baking, avoid using warped pans. Do not use a deep pan for shallow cakes, cookies, etc., as heat circulation across the top of these items is essential for even browning. To prevent excessive shrinkage, roast meats at a low temperature; 250° to 325° F, (121° to 163° C).

When rethermalizing frozen products, preheat the oven 50° F, (10° C), higher than the cooking temperature to compensate for heat loss during and after loading. Return the thermostat to the cooking temperature after loading.

To conserve energy, turn the oven off when not in use. If you cover pans with aluminum foil, be sure to crimp it tightly around the edges to prevent the foil from blowing off in the oven. Any food or other matter which becomes lodged in the fan must be removed as soon as the oven is cool.

Care & Cleaning

Painted Finish

Establish a regular cleaning schedule. Any spills should be wiped off immediately.

The oven should be permitted to cool down before cleaning exterior surfaces.

1. Wipe exposed, cleanable surface when cool with a mild detergent and hot water. Stubborn residue spots

may be removed with a light weight non metallic scouring pad. Dry thoroughly with a clean cloth.

2. Stainless steel should be cleaned using a mild detergent, a soft cloth and hot water. If necessary to use a nonmetallic scouring pad, always rub in the direction of the grain in the metal to prevent scratching. Use a water based stainless cleaner (Drackett Twinkle), if you want a high shine.

Stainless Steel

For routine cleaning just wash with a hot water and detergent solution. Wash just a small area at a time or the water will evaporate leaving the chemicals behind causing streaking.

Rinse the washed area with a clean sponge dipped in a sanitizing solution and wipe dry with a soft clean cloth before it can dry.

Use a paste (of water and a mild scouring powder) if you have to, but never rub against the grain. All stainless steel has been polished in one direction. Rub with the polish lines to preserve the original finish. Then thoroughly rinse as before.

To prevent fingerprints there are several stainless steel polishes on the market that leave an oily or waxy film. Do not use on surfaces that will be in contact with food.

Stainless steel may discolor if overheated. These stains can usually be removed by vigorous rubbing with a scouring powder paste.

Use only stainless steel, wood or plastic tools if necessary to scrape off heavy deposits of grease and oil. Do not use ordinary steel scrapers or knives as particles of the iron may become imbedded and rust. **STEEL WOOL SHOULD NEVER BE USED.**

Either a typical bleach solution or hot water can be used to sanitize stainless steel with out harm.

Oven Interior, (porcelain enamel)

NOTE: Disconnect line cord (if applicable) from power supply before cleaning or servicing.

1. Before cleaning oven interior, remove all oven racks and guides (if "RC" base). Oven racks and guides can be cleaned with a mild soap and warm water or run through dish washer.
2. The porcelain interior can be cleaned with oven cleaners such as "Easy-Off", or "Dow Oven Cleaner". Follow product manufacture's instructions for proper use.

Oven Interior (optional continuous clean)

NOTE: Disconnect line cord (if applicable) from power supply before cleaning or servicing.

1. “Break-In Period” - When the oven is new, operate the oven for at least two hours at high heat, with the oven empty, before normal cooking operation. Continue preheating the oven for two hours prior to use during the first two weeks. During this break-in period, it is important that the oven surfaces be kept clean of excessive soiling due to spillage.
2. How to put “continuous cleaning” action to work: Each day, after baking and roasting operations have ceased, empty the oven, turn the temperature control up to high heat (500°). This high heat will accelerate the cleaning action and reduce the time required to effectively clean the oven. Usually the cleaning operation will take about 45 to 60 minutes.
3. Heavy Staining - When the oven appears soiled, due to heavy staining, we suggest pre-heating the empty oven each day for 1 or 2 hours (depending on the condition of the oven) for effective results. Also, ordinary household ammonia has proven to be effective in removing baked-on “soil” build-up, and

has the beneficial effect of keeping the microscopic “pores” of the coating open and free to perform its cleaning action. An occasional light swabbing with household ammonia while the oven is at room temperature will prove extremely beneficial.

WARNING - Abrasives and Oven Cleaners should not be used - in order to maintain continuous cleaning action, it is very important to avoid the use of abrasive materials such as steel wool scouring pads, abrasives or sharp implements which can cause permanent damage to the surface coating. In addition, oven cleaners such as “Easy-Off” or “Dow Oven Cleaner” will clog the “PORES” of the special coating and will retard the cleaning action.

4. High temperature cleaning causes grease and food residue to be reduced to a fine powder. After oven has cooled, the powder should be brushed from the oven cavity.
5. Period “Tune-Up” - Although the oven appears clean, we recommend operating the oven at high heat for 2 hours approximately once each month. This will insure against build-up of solids in the pores of the coating.

Open Top Burners

Cleaning of the range top burner is a simple procedure, and, if done at regular intervals will prolong the life of the range and ensure good flame characteristics.

1. The most common problem with open burner ranges is spillage. Once the burner ports are partially plugged with food, the air-to-gas mixture is disturbed and results in an inefficient burner.
2. Wipe any spills as they occur.
3. Grids and trays should be removed daily, washed, rinsed and dried thoroughly.

4. Use a wire brush to clean the ports of the burners. Ignite and check for clogged holes.
5. If any clogged holes are apparent, the burner should be lifted out and brushed inside and out with a small venturi brush. Each port on the burner itself should be cleaned with a properly sized wire or thumb drill. Wash with soap and hot water if grease is observed on the burners. Dry thoroughly.
6. Reinstall and check the flame pattern. Readjust the air shutter if necessary.
7. If a yellow flame appears around the edges instead of being uniformly blue, it is usually a sign of grease and dirt in the throat of the burner. Remove and clean the burner and readjust the air shutter.

Cast Iron Top & Ring Grates

Cast iron top and ring grate(s) can be cleaned with mild soap and warm water. For baked on material, a wire brush can be used. Dry thoroughly. Lightly coat with vegetable oil to help prevent rust from forming.

At the rear of the cast iron top grate there are spill shields. These should be removed and cleaned. Replace after cleaning to prevent grease and spillovers dripping down the back of range.

Griddle

To produce evenly cooked, browned griddle products, keep griddle free from carbonized grease. Carbonized grease on the surface hinders the transfer of heat from the griddle surface to food product. This results in uneven browning and loss of cooking efficiency, and worst of all, carbonized grease tends to cling to grilled foods, giving them a highly unsatisfactory and unappetizing appearance. To keep the griddle clean and operating at peak performance, follow these simple instructions:

- A. **AFTER EACH USE** clean griddle thoroughly with a grill scraper or spatula. Wipe off any excess debris left from cooking process.
- B. **ONCE A DAY** clean griddle surface with a grill brick and grill pad. Remove grease container and clean thoroughly, in same manner as any ordinary cooking utensil.

- C. **ONCE A WEEK** clean griddle surface thoroughly. If necessary, use a grill stone or grill pad over the griddle surface. Rub with grain of the metal while still warm. A detergent may be used on the plate surface to help clean it, but care must be taken to be sure it is thoroughly removed. After removal of detergent, the surface of the plate should be covered with a thin film of oil to prevent rusting. To remove discolorations, use a non-abrasive cleaner. Before re-using the griddle **must** be reseasoned. Keep griddle drain tube to grease container clear at all times on those models without side grease container.

CAUTION: This griddle plate is steel, but the surface is relatively soft and can be scored or dented by careless use of spatula. Be careful not to dent, scratch, or gouge the plate surface. This will cause food to stick in those areas. Also, note, since this is a steel griddle if a light coating of oil is not always present rust will develop on exposed & uncoated areas.

Hot Tops

While the surface is still slightly warm, wipe down with a clean burlap cloth. Burnt on spillage should be scraped off. If necessary, remove the plate and wash in a sink with soap and hot water. Dry thoroughly. In damp climates, wipe down with a light coating of oil to prevent rusting. Avoid excessive use of water as this could damage the surface and the controls below.

NOTE: Steel griddle and hot top surface will “tone” (blue/brown discoloration) from heat. This toning will not diminish function or operation and is not a defect.

SunFire