

Operations & Service Manual

EOF-10-10/FFLT/24, EOF-10-10/FFLT/24/24
EOF-20/FFLT/24, EOF-20/FFLT/24/24



Model: EOF-10-10/FFLT/24/24



Model: EOF-20/FFLT/24/24



Giles Enterprises, Inc.

2750 Gunter Park Drive West • Montgomery, AL 36109 USA

Fax: 334.239.4117 • Website: www.gfse.com

Service Hotline (Toll Free): 800.554.4537 (USA & Canada Only)

Form No. 60221 (Release date: 11/99) Revised: 07/15/12; Rev. E)



LIMITED WARRANTY

- Subject to the terms and conditions of this Limited Warranty as herein stated, all Giles Enterprises, Inc., Foodservice Equipment and parts purchased new from an authorized Giles Enterprises, Inc., representative are warranted as to defects in material or workmanship for a period of 12 months from the date of installation, provided, however, that with regard to labor costs in connection with this warranty, see below. All installations must be made by a qualified installing agency in accordance with all applicable codes and/or regulations in the jurisdiction in which installed. Limited warranty coverage is extended to the original owner only and is void if the unit is resold.
- During the Limited Warranty period, Giles Enterprises, Inc. will replace or recondition, at its factory, any part or parts of this unit which Giles Enterprises, Inc. inspectors judge defective, provided the unit has been subjected to normal usage, properly installed, operated and serviced. This Limited Warranty does not cover cosmetic damage, and damage due to acts of God, accident, misuse, alteration, negligence, abuse of the Giles Foodservice Equipment or the use of unorthodox repair methods. All parts replaced under this Limited Warranty carry only the unexpired term of this Limited Warranty. Limited Warranty service may be furnished only by an authorized Giles Enterprises, Inc., representative.
- If Limited Warranty service is requested, Giles Enterprises, Inc., will send factory-authorized service representatives to repair, recondition, replace or inspect units of its manufacture with such labor being rendered without cost to owner for ninety (90) days from the date of installation. Otherwise, service, including labor and transportation charges or other expenses, in connection with the removal or installation of any part or parts supplied under this Limited Warranty, are specified on the original sales contract between the purchaser and the authorized Giles Enterprises, Inc., representative.
- Giles Enterprises, Inc. reserves the right to change or improve its equipment and parts in any way without obligation to alter such equipment or parts previously manufactured.
- Giles Enterprises, Inc. makes no further warranties, express or implied including implied warranties of merchantability or fitness for a particular purpose, and has no other obligation or liability not specifically stated herein.
- Repair or replacement as provided under this limited warranty is the exclusive remedy. Giles Enterprises, Inc., shall not be liable for any incidental or consequential damages for breach of any express or implied warranty on this product, except to the extent prohibited by applicable law. Any implied warranty of merchantability or fitness for a particular purpose on this product is limited in duration to the duration of this limited warranty.
- Used Giles Enterprises, Inc., Foodservice Equipment or parts or Giles Enterprises, Inc., Foodservice Equipment or parts not purchased from an authorized Giles Enterprises, Inc., representative, carry no warranties, express or implied.



Table Of Contents

EOF-10-10/FFLT/24, EOF-10-10/FFLT/24/24
EOF-20/FFLT/24/24, EOF-20/FFLT/24/24

| | |
|--|------------|
| Safety | vii |
| Safety Overview | vii |
| Specific Safety Precautions | viii |
| | |
| 1. Introduction | 1 |
| 1-01. Construction | 1 |
| 1-02. Standard Features | 1 |
| 1-03. Optional Features | 1 |
| 1-04. Specifications | 2 |
| 1-04.1. Overall Dimensions for EOF-10-10/FFLT/24(24) or EOF-20/FFLT/24(24) | 2 |
| 1-04.2. Regulatory Listings | 3 |
| 1-04.3. Basket Size | 3 |
| 1-04.4. Vat Size and Capacity | 3 |
| 1-04.5. Shipping Specifications (Crated) | 4 |
| | |
| 2. Installation | 5 |
| 2-01. Location | 5 |
| 2-02. Unpacking | 6 |
| 2-03. Shipping Bars | 7 |
| 2-04. Electrical Requirements | 8 |
| 2-04.1. EOF-10-10 Electrical Specifications | 8 |
| 2-04.1. EOF-20 Electrical Specifications | 8 |
| 2-04.2. EOF-24 Electrical Specifications | 9 |
| 2-05. Electrical Connections | 9 |
| 2-05.1. Electrical Connections Diagram | 10 |
| 2-06. Ventilation of Fryer | 10 |
| | |
| 3. Overview | 11 |
| 3-01. EOF-10-10 Basket Elevator and Baskets | 12 |
| 3-02. EOF-10-10 Control Panel | 14 |
| 3-03. EOF-10-10 Lower Cabinet Area | 16 |
| 3-04. EOF-20 Basket Elevator and Baskets | 18 |
| 3-05. EOF-20 Control Panel | 20 |
| 3-06. EOF-20 Lower Cabinet Area | 22 |
| 3-07. FFLT Table | 24 |
| 3-08. FFLT Control Panel | 26 |
| 3-09. FFLT Lower Cabinet Area | 28 |
| 3-10. EOF-24 Basket Hanger and Baskets | 30 |
| 3-11. EOF-24 Control Panel | 32 |
| 3-12. EOF-24 Lower Cabinet Area | 34 |
| 3-13. Filter Pan Assembly | 36 |
| 3-14. Accessories (Included) | 38 |
| 3-15. Accessories (Not Included) | 41 |

| | | |
|-----------|---|-----------|
| 4. | Unit Preparation | 43 |
| 4-01. | Settings before each test | 43 |
| 4-02. | Power test | 45 |
| 4-03. | Heating Element test | 46 |
| 4-04. | Filter Pump Test | 47 |
| 4-05. | Perform Boil Out Procedure | 48 |
| 4-06. | Clean Filter Pan. | 48 |
| 5. | Fryer Operation | 49 |
| 5-01. | Cooking Controller | 50 |
| 5-01.1. | Buttons and Functions | 51 |
| 5-01.2. | Programming the Cooking Temperature | 52 |
| 5-01.3. | Programming a Cooking Time. | 53 |
| 5-01.4. | Start a cooking time | 54 |
| 5-01.5. | Cancel the currently running cooking time. | 54 |
| 5-01.6. | Manually lowering and raising the cooking basket (Basket Elevator Only) | 54 |
| 5-01.7. | Displaying remaining cooking time. | 55 |
| 5-01.8. | Displaying the actual temperature of the liquid shortening | 55 |
| 5-02. | Cooking Procedure | 56 |
| 5-03. | Filtering Liquid Shortening | 61 |
| 5-04. | Removal of Liquid Shortening | 64 |
| 5-05 | Using the <u>Optional</u> Renewable Filter Media (SSFS)... | 67 |
| 5-05.1 | Washing the Renewable Filter Media (SSFS). | 67 |
| 5-06. | Normal Shut-Down | 68 |
| 5-07. | Emergency Shut-Down. | 68 |
| 6. | Cleaning | 69 |
| 6-01. | Boil-Out Procedure (Cleaning the Fry Pot) | 69 |
| 6-02. | Cleaning the Filter Pan and replacing Filter Paper after Boil Out | 72 |
| 6-03. | Cleaning the Filter Pan and replacing the Filter Paper daily | 73 |
| 7. | Troubleshooting | 75 |
| 7-01. | Temperature Control System | 75 |
| 7-02. | Oil Filtration System | 77 |
| 7-03. | Basket Elevator System (Basket Elevator Option Only) | 78 |
| 8. | Parts List | 79 |
| 8-01. | Parts Ordering and Service Information | 79 |
| 8-02. | EOF-10-10 Control Panel & Front Header | 80 |
| 8-03. | EOF-10-10 Front Lower Cabinet | 82 |
| 8-04. | EOF-10-10 Rear Lower Cabinet. | 84 |
| 8-05. | EOF-20 Control Panel & Front Header | 86 |
| 8-06. | EOF-20 Front Lower Cabinet. | 88 |
| 8-07. | EOF-20 Rear Lower Cabinet | 90 |
| 8-08. | EOF-24 Control Panel & Front Header | 92 |

Table Of Contents

EOF-10-10/FFLT/24, EOF-10-10/FFLT/24/24
EOF-20/FFLT/24/24, EOF-20/FFLT/24/24

| | | |
|-------|---------------------------------|-----|
| 8-09. | EOF-24 Front Lower Cabinet..... | 94 |
| 8-10. | EOF-24 Rear Lower Cabinet..... | 96 |
| 8-11. | FFLT Front..... | 98 |
| 8-12. | FFLT Rear..... | 100 |
| 8-13. | Filter Pan..... | 102 |



Notes:

Safety

Safety Overview

The instructions contained in this manual have been prepared to aid you in learning the proper procedures for installing and servicing your unit.

Throughout this manual, safety precautions are identified through the use of the safety alert symbol and three signal words: **DANGER**, **WARNING**, and **CAUTION**. All safety alert information precedes the step(s) to which they apply. Suggested, recommended, or other noteworthy information is identified through the use of **NOTES**. Additionally, certain words are used to indicate a specific meaning or to add emphasis.

The following words are used as indicated throughout the manual:

Shall: understood to be mandatory.

Should: understood to be advisory.

May: understood to be permissive.

Will: indicates a future event/condition to occur.

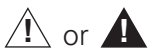

(Safety Alert Symbol)

Used in conjunction with signal words (**DANGER**, **WARNING**, or **CAUTION**) to alert you of potential personal injury hazards, immediately preceding precautionary measures that pertain to subsequent step(s). Obey all safety messages that follow these symbols to avoid possible injury or death. Failure to adhere to safety precautions identified by the safety alert symbol may also void the warranty.

DANGER

- Indicates an imminently hazardous situation which, if not avoided, will result in death or serious injury. Use of this is limited to the most extreme situations.

WARNING

- Indicates a potentially hazardous situation which, if not avoided, could result in death or serious injury.

CAUTION

- Indicates a potentially hazardous situation which, if not avoided, may result in minor or moderate injury. Also used to alert against unsafe practices.

CAUTION

- When used without the safety alert symbol, **CAUTION** indicates a potentially hazardous situation which, if not avoided, may result in equipment/property damage, and void the warranty.

NOTE:

- Identifies suggested, recommended, or other noteworthy information.

Specific Safety Precautions

For your safety, please observe the following precautions when operating or servicing this unit. Read the following important safety information to avoid personal injury and/or damage to the equipment.

DANGER

- Turn off the unit and unplug the power cord before cleaning or performing maintenance.
- **DO NOT** hose down the unit's interior or exterior with water.
- Failure to comply with these **DANGER** notices will result in death or serious injury, equipment/property damage, and void the warranty.

WARNING

- Consult a qualified electrician to ensure that:
 - all electrical specifications and codes are met.
 - circuit breakers and wiring are of sufficient rating and gauge.
- The unit must be properly grounded and all electrical specifications must be met during installation.
- Improper installation, adjustment, alteration, service or maintenance could result in death or serious injury, equipment/property damage, and void the warranty.
- **DO NOT** use or store gasoline or other flammable liquids or vapors in the vicinity of this or any other electrical appliance!
- Failure to comply with **WARNING** notices could result in death or serious injury and equipment/property damage and void the warranty.

CAUTION

- The unit must remain in the upright (vertical) position.
- Exercise care when removing the wooden crate from around the unit.
- **DO NOT** operate the unit unless you fully understand the components and their intended functions (see Section 3).
- The unit and its parts are **HOT!**
Exercise caution when operating, loading/unloading food, cleaning or servicing.
Wearing of thermal oven mitts is recommended.
- Failure to comply with **CAUTION** notices may result in minor or moderate injury, equipment/property damage, and void the warranty.

CAUTION

- Food products must be maintained at a temperature of 150°F (65.5°C) minimum or in accordance with local or state health regulations.
- **Fryers must be adequately and properly grounded. Improper grounding may result in electrical shock. Always refer to your local electrical code to ensure proper grounding of this or any other electrical equipment. Always consult with an electrician or other qualified service person to ensure breakers and wiring are of sufficient rating and gauge for the equipment being operated.**
- Giles Electric Fryers are available from the factory wired for various voltages, phase and hertz. Check the rating plate on the front of the fryer to determine the correct power supply.
- Ensure the fry kettle is positioned in a secure, safe location with the casters in the locked position.
- Consult an electrician to ensure all electrical specifications have been met and the unit is properly grounded. The wiring diagrams contained in this manual should aid your electrician in the installation of your fryer.
- Due to the high temperature of shortening in your fryer during cooking, it is extremely important the user exercise caution in the operation of this equipment to avoid personal injury.
- Before attempting to operate the unit, refer to Section 3 to familiarize yourself with the various control functions.
- Be careful not to puncture the filter paper when using the brush to unclog the Drain Valve.
- Allow the unit to cool down a minimum of 15 minutes before cleaning or servicing.

CAUTION

- The electronic components of the Control Panel are impact-sensitive. Exercise care around the Control Panel to maintain proper operation.
- **DO NOT** install the unit next to combustible walls and materials. Failure to maintain safe distances may result in fire.
- During cleaning of the unit:
 - **DO NOT** steam clean.
 - **DO NOT** use products containing chlorine.
 - **DO NOT** use abrasive products, steel wool or scouring pads.
 - **DO NOT** use oven cleaner.
- Failure to comply with these **CAUTION** notices may result in equipment/property damage and void the warranty.
- Failure to comply with these **CAUTION** notices may violate local health codes.
- **DO NOT** Modify, Alter or Add Attachments to this Equipment!

NOTE:

- If the crate in which the unit is shipped is damaged upon receipt, immediately inspect the unit and notify the carrier of any damage to the unit.
- To aid the electrician, an electrical wiring diagram is contained in this manual. Refer to the wiring diagram during installation or servicing.
- Comply with all appropriate state and/or local health regulations regarding the cleaning and sanitation of equipment.

1. Introduction

Congratulations on the purchase of your new Giles equipment, Model EOF-10-10/FFLT/24/24 or EOF-10-10/FFLT/24, EOF-20/FFLT/24/24 or EOF-20/FFLT/24, manufactured by Giles Enterprises, Inc., Montgomery, Alabama (USA), hereafter referred to as "Giles". Every unit is thoroughly inspected and tested prior to shipment. Proper care and maintenance will ensure years of trouble-free service.

To help protect your investment in this state-of-the-art cooking equipment, we recommend you take a few moments to familiarize yourself with the installation, cleaning and maintenance procedures contained in this manual. Adherence to these recommended procedures minimizes the potential for costly "Down-Time" and equipment repairs. Please retain this manual for future reference.

1-01. Construction

Model EOF-10-10/FFLT/24, EOF-10-10/FFLT/24/24, EOF-20/FFLT/24/24 and EOF-20/FFLT/24/24, exterior and fry vats are constructed of stainless steel.

1-02. Standard Features

Temperature Controller -used to control the temperature of the cooking oil and the cooking time.

Oil Filtration System -used to extend the life of cooking oil.

FFLT (Fried Food Landing Table) -used as a convenient location to place cooked product.

1-03. Optional Features

Automatic Basket Lift -used to automatically lift cooked product from hot cooking oil at the end of the cooking cycle.

1-04. Specifications

1-04.1. Overall Dimensions for EOF-10-10/FFLT/24(24) or EOF-20/FFLT/24(24)

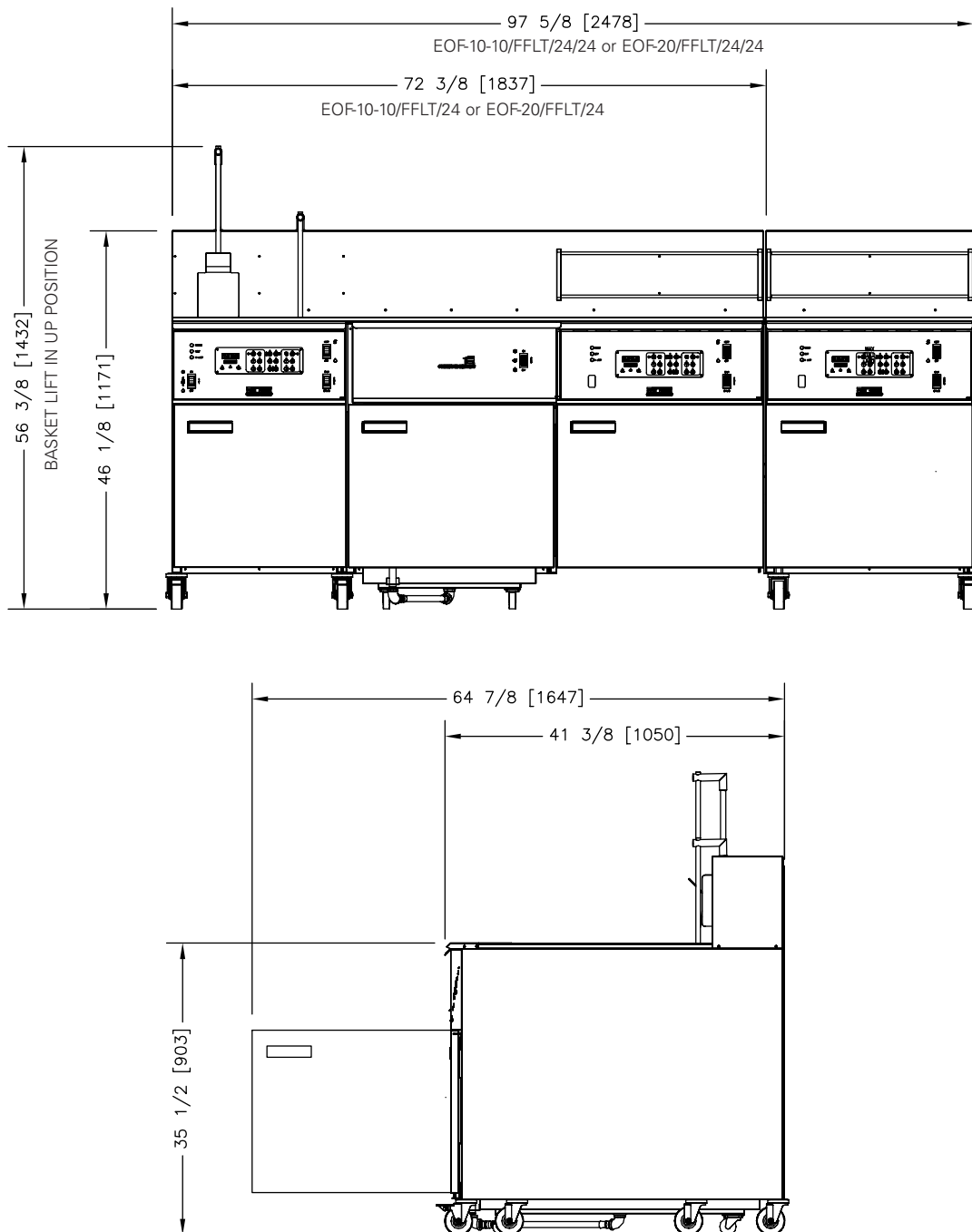

INCHES [MILLIMETERS]

1-04.2. Regulatory Listings

UL (US and Canada)
 UL Sanitation

1-04.3. Basket Size

| Model | Basket Size | | | | | | Volume | |
|------------------|-------------|-------|-------|--------|--------|-------|------------|-------------|
| | Length | | Width | | Height | | cubic inch | cubic meter |
| | in | mm | in | mm | in | mm | | |
| EOF-10 or EOF-20 | 9.00 | 228.6 | 18.50 | 469.9 | 5.5 | 139.7 | 811 | 0.005 |
| EOF-24 | 11.00 | 279.4 | 22.75 | 577.85 | 5.0 | 127 | 1176 | 0.019 |

1-04.4. Vat Size and Capacity

| Model | Length (Inside) | | Width (Inside) | | Height (Top of element to oil level line) | | Liquid Shortening Capacity (Bottom of Vat to Oil level) | | | |
|--------|-----------------|-----|----------------|-----|---|-----|---|----|-----|------|
| | In | mm | In | mm | In | mm | Lbs | Kg | Gal | Lt |
| EOF-10 | 20 | 508 | 10 | 254 | 4 1/2 | 114 | 55 | 25 | 8 | 29.5 |
| EOF-20 | 20 | 508 | 20 | 508 | 4 1/2 | 114 | 110 | 50 | 16 | 59 |
| EOF-24 | 24 | 610 | 24 | 610 | 4 1/2 | 114 | 160 | 73 | 23 | 86 |

1-04.5. Shipping Specifications (Crated)

| Model | Net Weight | | Crated Size | | | | | | Volume | |
|----------------------|------------|-----|-------------|------|-------|------|--------|------|------------|--------------|
| | Lbs | Kg | Length | | Width | | Height | | Cubic Feet | Cubic Meters |
| | | | In | mm | In | mm | In | mm | | |
| EOF-10-10/FFLT/24 | 1069 | 485 | 108 | 2743 | 50 | 1270 | 61 | 1549 | 193.75 | 5.5 |
| EOF-10-10/FFLT/24/24 | 1197 | 543 | 108 | 2743 | 50 | 1270 | 61 | 1549 | 193.75 | 5.5 |
| EOF-20/FFLT/24 | 1069 | 485 | 108 | 2743 | 50 | 1270 | 61 | 1549 | 193.75 | 5.5 |
| EOF-20/FFLT/24/24 | 1197 | 543 | 108 | 2743 | 50 | 1270 | 61 | 1549 | 193.75 | 5.5 |

2. Installation

This section provides a summary of the procedures necessary for proper installation of your new unit. To prevent personal injury or equipment damage, please ensure the following steps are taken.

2-01. Location

 **CAUTION**

- **DO NOT MODIFY, ALTER OR ADD ATTACHMENTS TO THIS EQUIPMENT**

1. Keep the appliance and surrounding area free and clear from combustible materials. {(3")}(7.6cm) for Fryer.}
2. Please note wiring diagrams for this appliance are located in the rear of this manual. Ensure the wiring diagram corresponds with the model being operated.
3. Please ensure this appliance is electrically grounded in accordance with local codes, or in the absence of local codes, with the National Electrical Code, ANSI/NFPA NO. 70-1999.
4. Please provide adequate room for servicing and proper operation of this appliance. Also, provide adequate ventilation in the operating area where necessary.
5. Always consult with an electrician or other qualified individual prior to installation.
6. Ensure voltage and amperage supplied to the unit are as specified on the fryer's rating plate.
7. Make sure this unit is in a secure position and will not move. Locking casters are supplied on this unit—use them!
8. This appliance is to be installed, used and maintained in accordance with the Standard for Ventilation Control, and Fire Protection of Commercial Cooking Operations, NFPA 96-1994.

Compliance with the above steps will help to ensure safe and proper installation of your fryer. If you have any questions concerning these procedures, contact your local Giles distributor or other qualified service person.

2-02. Unpacking

Your Giles Fryer may arrive enclosed by a wooden crate. The Fryer is secured to a wooden platform by means of high-tensile strength strapping.

CAUTION

- Exercise care when lifting or moving the unit.
- Exercise care when removing the wooden crate from around the unit.
- Failure to comply with these CAUTION notices may result in minor or moderate injury, equipment/property damage, and void the warranty.

NOTE:

- If crate is damaged, immediately inspect the unit and notify the carrier of any damage to the unit.

1. Carefully cut and remove the plastic shipping wrap and the strapping mentioned above.
2. Use pliers to loosen wire hooks which secure the wooden crate around the fryer. Remove the wooden crate.
3. Carefully remove the fryer from the shipping platform. Your new fryer is extremely heavy, the uncrated weight for the EOF-10-10/FFLT/24 and the EOF-20/FFLT/24 is 769 lbs (349 kg); the EOF-10-10/FFLT/24/24 and EOF-20/FFLT/24/24 is 897 lbs (407 kg), only use a fork lift when lifting this equipment, refer to 2-03.

2-03. Shipping Bars

Reinforcement bars have been attached to the framework, at both the front and rear of the fryer bank. These bars are provided as a stabilizing reinforcement for lifting the unit and during installation. Please note the following:

1. The bars must remain in place until the fryer is positioned in the designated final position.
2. Open or remove front doors before placing forks underneath the unit.
3. The bars are designed to be used as a lifting point for fork trucks or other type lifting devices.

CAUTION

- **Caution must be used whenever attempting to lift any fryer or placing forks for lifting to insure that components on the fryer are not hit by the forks or damaged due to lifting.**

4. After the banked unit is in the final position, the front bar must be removed to permit installation and proper operation of the fryer Filter Pan.

NOTE:

- **The Front Bar must be removed to allow the installation of the Filter Pan.**

5. The rear bar is intended to remain in place and will not affect fryer operation.
6. Remove the front bar by removing all the screws fastening the bar to the fryer frame. Note that the bar is fastened to the fryer at all vertical uprights.
7. Once the screws are removed, the bar can be removed from the fryer.
8. Install the screws that are included with the shipping documents, these screws are designed to replace the screws removed when removing the shipping bar.
9. Close or reinstall the unit's front doors.
10. Once the front bar is removed, then please follow the instructions provided in the operation manual for the remaining installation and operation of the equipment.

NOTE:

- **Giles is not liable for damage to a unit caused by the improper use of forklifts or other handling equipment, or by premature removal of the reinforcing bars. The bars must remain in place until the fryer has been located in the designated final operating position. Failure to follow these instructions could void the warranty. Giles is not liable for injuries incurred during installation of this equipment. Installation of this equipment is the sole responsibility of the purchaser.**

2-04. Electrical Requirements

⚠ CAUTION

- Fryers must be adequately and properly grounded. Improper grounding may result in electrical shock. Always refer to your local electrical code to ensure proper grounding of this or any other electrical equipment. Always consult with an electrician or other qualified service person to ensure breakers and wiring are of sufficient rating and gauge for the equipment being operated.

The EOF-10-10, EOF-20 and EOF-24 are available from the factory in the voltages and phases listed below. Check the rating plate on the rear of the fryer to determine the correct power supply.

2-04.1. EOF-10-10 Electrical Specifications

| Voltage | Phase | Watts | Amps | | | Circuit Breaker required |
|---------|-------|--------|------|----|----|--------------------------|
| | | | L1 | L2 | L3 | |
| 208 | 3 | 24,000 | 68 | 66 | 68 | 80 |
| 240 | 3 | 24,000 | 59 | 57 | 59 | 75 |
| 480 | 3 | 24,000 | 31 | 29 | 31 | 50 |

2-04.1. EOF-20 Electrical Specifications

| Voltage | Phase | Watts | Amps | | | Circuit Breaker required |
|---------|-------|--------|------|-----|----|--------------------------|
| | | | L1 | L2 | L3 | |
| 208 | 1 | 24,000 | 115 | 115 | — | 150 |
| 208 | 3 | 24,000 | 72 | 46 | 72 | 80 |
| 240 | 1 | 24,000 | 100 | 100 | — | 125 |
| 240 | 3 | 24,000 | 68 | 44 | 68 | 75 |
| 480 | 3 | 24,000 | 34 | 22 | 34 | 50 |

2-04.2. EOF-24 Electrical Specifications

| Voltage | Phase | Watts | Amps | | | Circuit Breaker required |
|---------|-------|--------|------|-----|----|--------------------------|
| | | | L1 | L2 | L3 | |
| 208 | 1 | 30,000 | 144 | 144 | — | 200 |
| 208 | 3 | 30,000 | 72 | 92 | 72 | 100 |
| 240 | 1 | 30,000 | 125 | 125 | — | 150 |
| 240 | 3 | 30,000 | 68 | 88 | 68 | 100 |
| 480 | 3 | 30,000 | 34 | 44 | 34 | 50 |

2-05. Electrical Connections

1. Install appropriate Circuit Breakers in Main Breaker Box! See Table 2-04.
2. Connect Flexible Conduit from Main Breaker Box to Quick Disconnect Box.
3. Connect Flexible Conduit from Quick Disconnect Box to the Fryer. Allow enough Conduit so Fryer can be moved away from the wall for cleaning and servicing. See Figure 2-05.1.
4. Open Fryer Door and remove Service Box Cover. See Figure 2-05.1.
5. Connect the electrical ground wire between the Terminal Block Ground Lug and a proper earth ground.
6. Route appropriate size Power Wires to the Fryer.
7. Connect the Power Wires to the appropriate Terminal Blocks located in the Service Box. See Figure 2-04.1.
8. Reinstall Service Box Cover and close the Fryer Door.

2-05.1. Electrical Connections Diagram

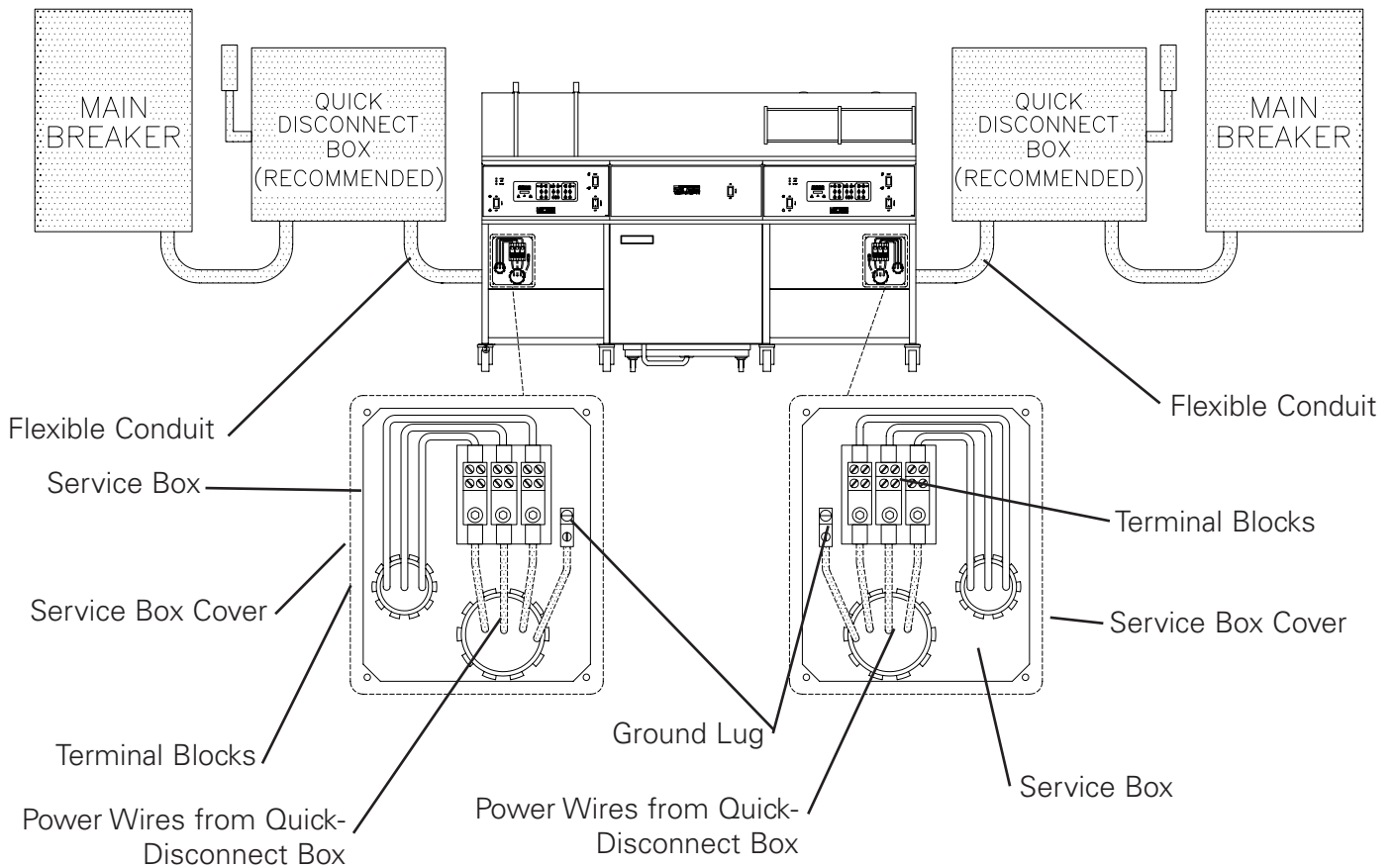

2-06. Ventilation of Fryer

NOTE:

- Guidelines for proper ventilation system requirements differ from location to location. Always consult with local authorities to ensure compliance.

Consult a professional ventilation or heating and air conditioning company for assistance in designing a Ventilation hood for this unit.

3. Overview

The following section provides a brief overview of the components, functions, and accessories of the unit. Please review this section carefully before proceeding any further.

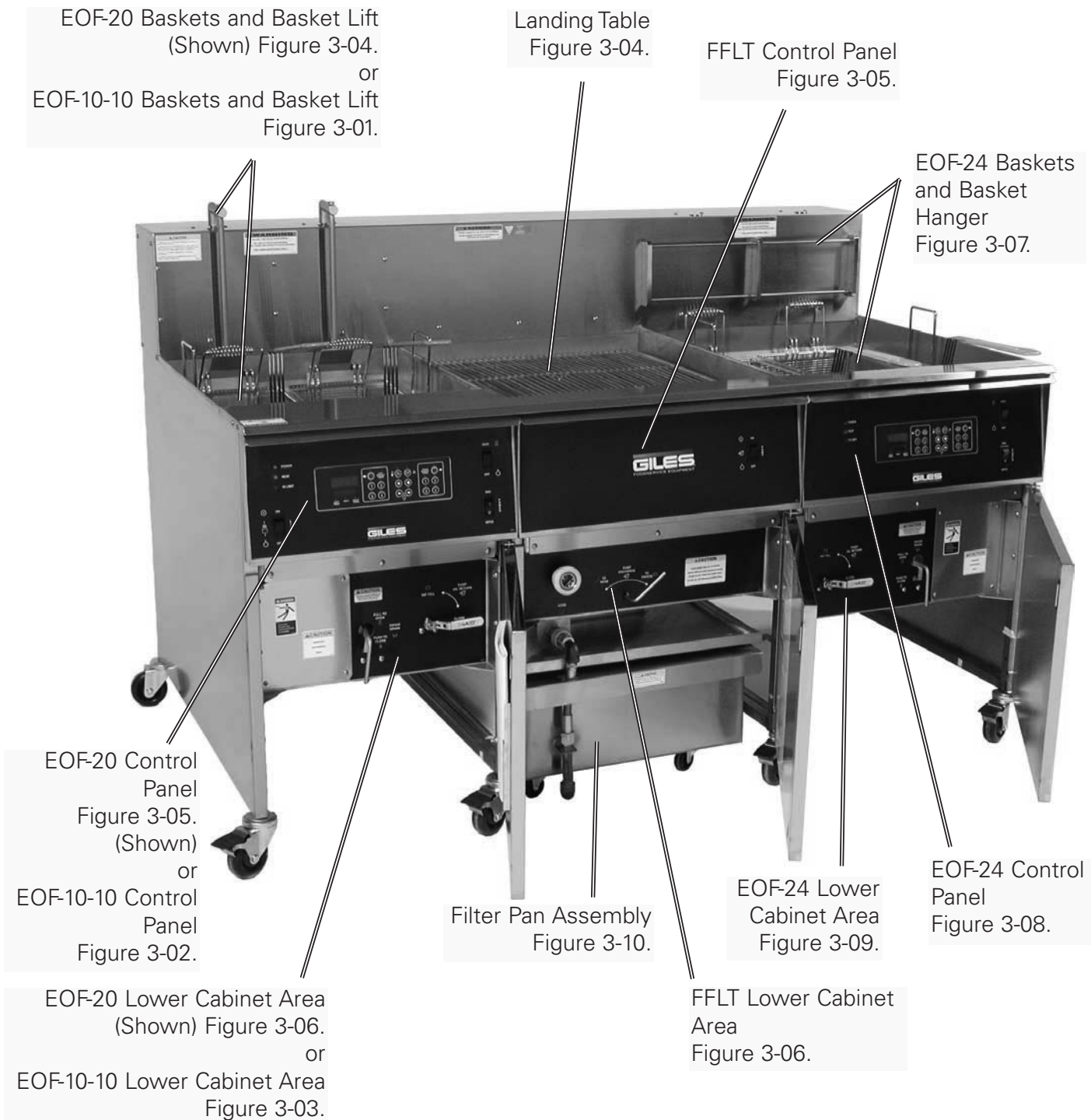

3-01. EOF-10-10 Basket Elevator and Baskets

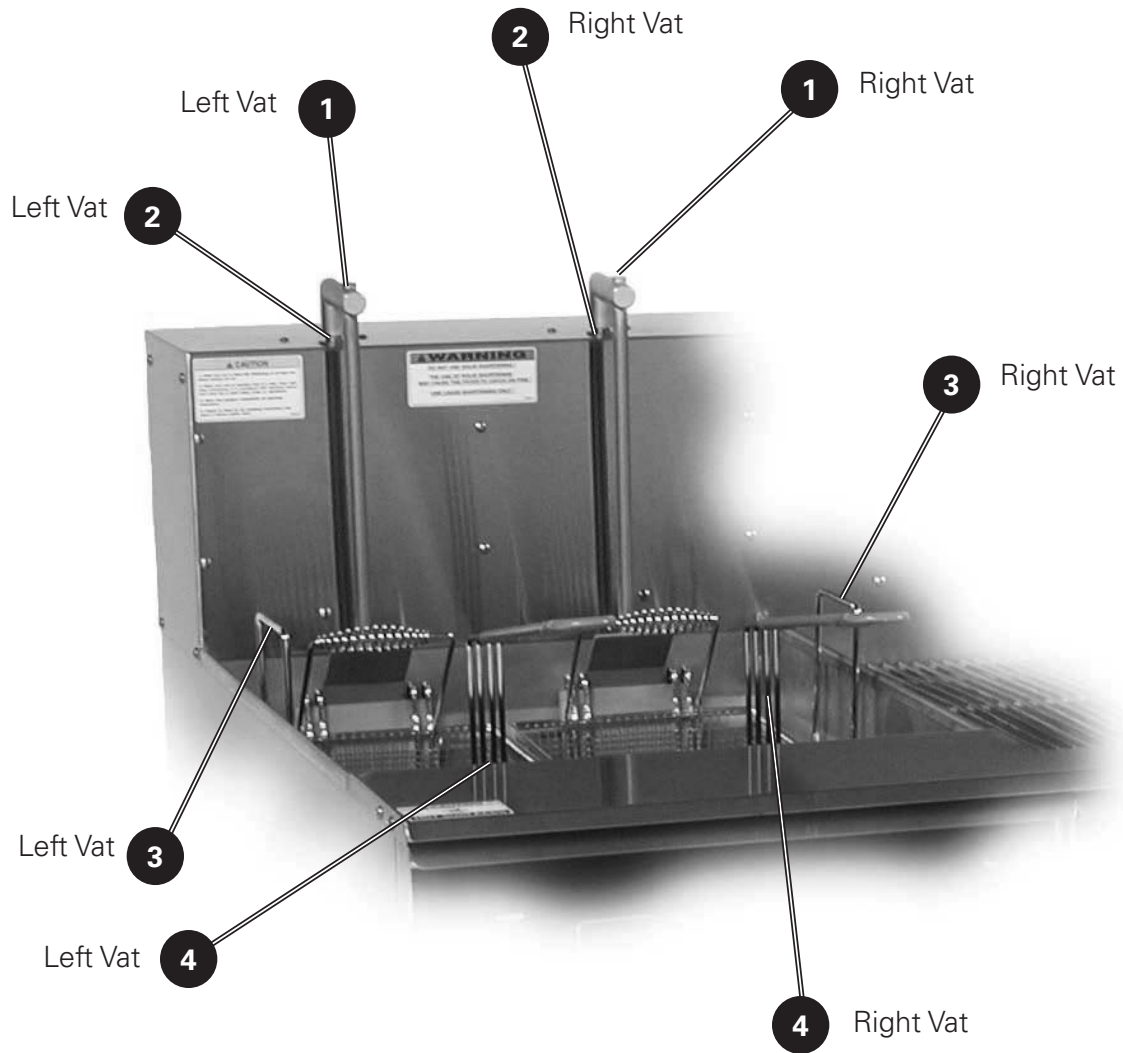

 **CAUTION**

- Always use Oven Mitts when using any of these parts. Parts will become very hot during normal use.

3-01. EOF-10-10 Basket Elevator (Optional) and Baskets

| Item | Description | Function |
|------|--------------------|---|
| 1 | Basket Carrier (2) | Used to hold the basket in the correct position when the basket is lifted or lower by the elevator. |
| 2 | Elevator (2) | Used to lower and lift the basket from the Fry Pot. |
| 3 | Crumb Screen | Used inside the Fry Pot to prevent excess breading or product from contacting the Heating Elements. |
| 4 | Basket (2) | Used for cooking product. |

3-02. EOF-10-10 Control Panel



3-02. EOF-10-10 Control Panel

| Item | Description | Function |
|------|-------------------------------------|---|
| 1 | Power Switch | The Power Switch is used to turn power ON or OFF to the unit. |
| 2 | Heat Switch (Left Vat) | The Heat Switch is used to turn power to elements ON and OFF. Place the Heat Switch in the OFF position when programming the controller or shutting down the unit. Place in ON position when ready to heat the oil. |
| 3 | Controller | The Electronic Controller is used for setting a cooking temperature and cooking times. |
| 4 | High-Limit Indicator (Left Vat) | The Red High-Limit Light indicates an alarm condition. It is illuminated when power is shut-off to the heating elements by the overheat safety shutdown control circuit. Should this light come on during operation, refer to the Troubleshooting, Section 7, of this manual. COOKING ACTIVITIES SHOULD BE DISCONTINUED UNTIL CAUSE IS DETERMINED! |
| 5 | Heat Indicator Light (Left Vat) | The Orange Heat Indicator Light is illuminated when the Heat Switch is in the ON position and the heating elements are energized. The light is off during intervals when oil is at setpoint and elements are de-energized. |
| 6 | Power Indicator Light | The Green Power Light is illuminated whenever the fryer's Power Switch is in the ON position. |
| 7 | Elevator Lift Switch | The Elevator Switch is used activate or deactivate the Basket Lifts. If the switch is ON the Lift will lower when a cooking cycle starts and rise when a cooking cycle ends. If the switch is OFF the Basket Lifts will not operate. (This switch controls both left and right basket lifts) |
| 8 | High-Limit Indicator (Right Vat) | The Red High-Limit Light indicates an alarm condition. It is illuminated when power is shut-off to the heating elements by the overheat safety shutdown control circuit. Should this light come on during operation, refer to the Troubleshooting, Section 7, of this manual. COOKING ACTIVITIES SHOULD BE DISCONTINUED UNTIL CAUSE IS DETERMINED! |
| 9 | Heat Indicator Light (Right Vat) | The Orange Heat Indicator Light is illuminated when the Heat Switch is in the ON position and the heating elements are energized. The light is off during intervals when oil is at setpoint and elements are de-energized. |
| 10 | Heat Switch (Right Vat) | The Heat Switch is used to turn power to elements ON and OFF. Place the Heat Switch in the OFF position when programming the controller or shutting down the unit. Place in ON position when ready to heat the oil. |

3-03. EOF-10-10 Lower Cabinet Area

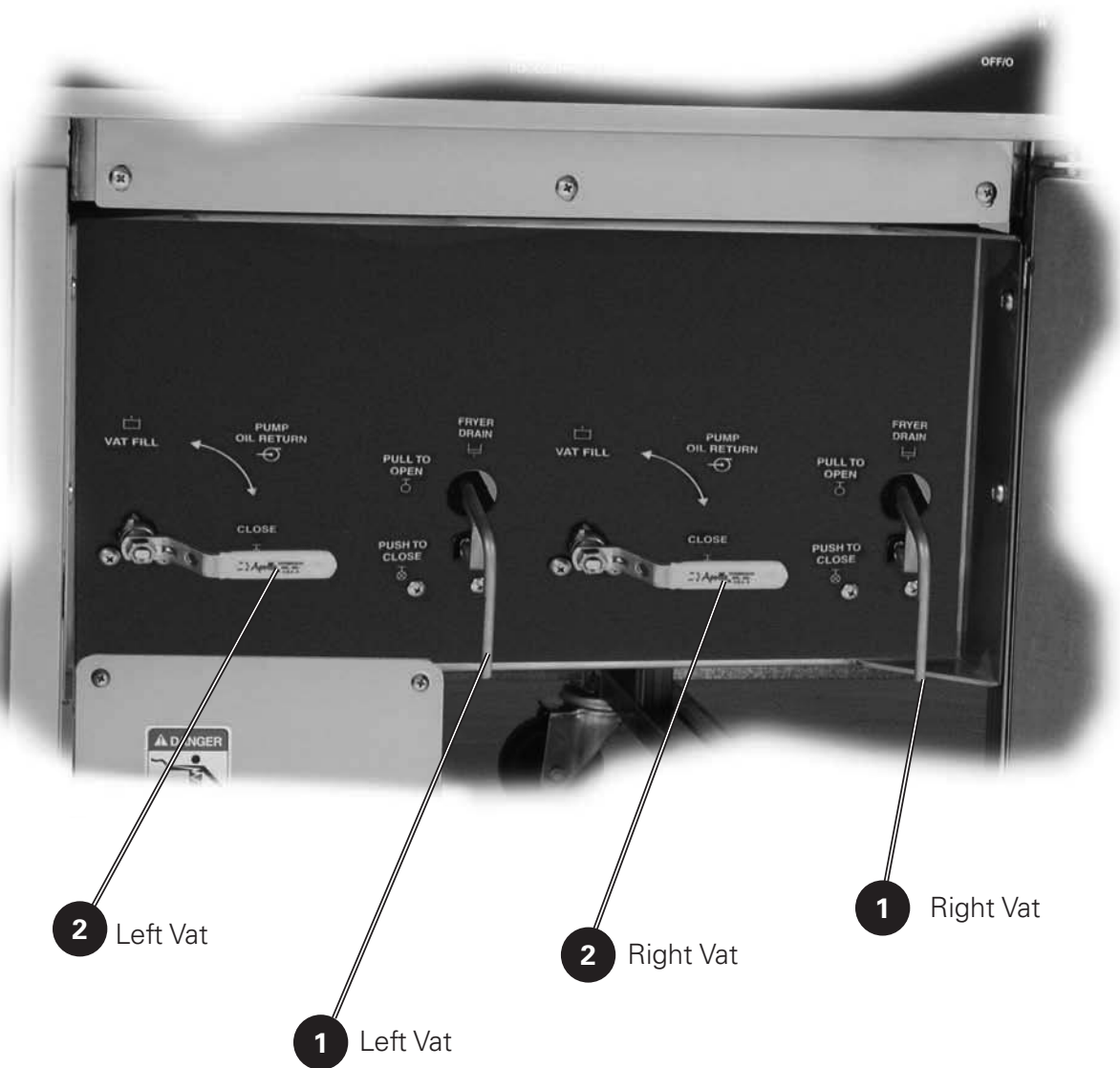

3-03. EOF-10-10 Lower Cabinet Area

| Item | Description | Function |
|------|------------------------|--|
| 1 | Drain Valve Handle | <p>Used to drain the Fry Pot. Always ensure the Handle is closed and locked prior to adding cooking oil or boil out solution. Your fryer will not heat if this Drain Valve Handle is not completely closed and locked.</p> <p>⚠ DANGER</p> <p>ALWAYS ENSURE THE HEAT SWITCH IS IN THE OFF POSITION BEFORE OPENING THIS VALVE. FAILURE TO COMPLY WITH THIS DANGER NOTICE COULD RESULT IN A FIRE, CAUSING DEATH OR SERIOUS INJURY AND/OR EQUIPMENT/PROPERTY DAMAGE AND VOID THE WARRANTY.</p> <p>⚠ WARNING</p> <p>NEVER DRAIN OIL INTO THE FILTER PAN FROM MORE THAN ONE FRY POT AT A TIME. DOING SO WILL CAUSE THE FILTER PAN TO OVERFLOW. ALWAYS PUMP OIL FROM THE FILTER PAN BACK TO A FRY POT OR TO A DISPOSAL TANK BEFORE DRAINING ANOTHER FRY POT.</p> |
| 2 | Pump Oil Return Handle | Used when Filtering to return oil to the Fry Vat. |

3-04. EOF-20 Basket Elevator and Baskets

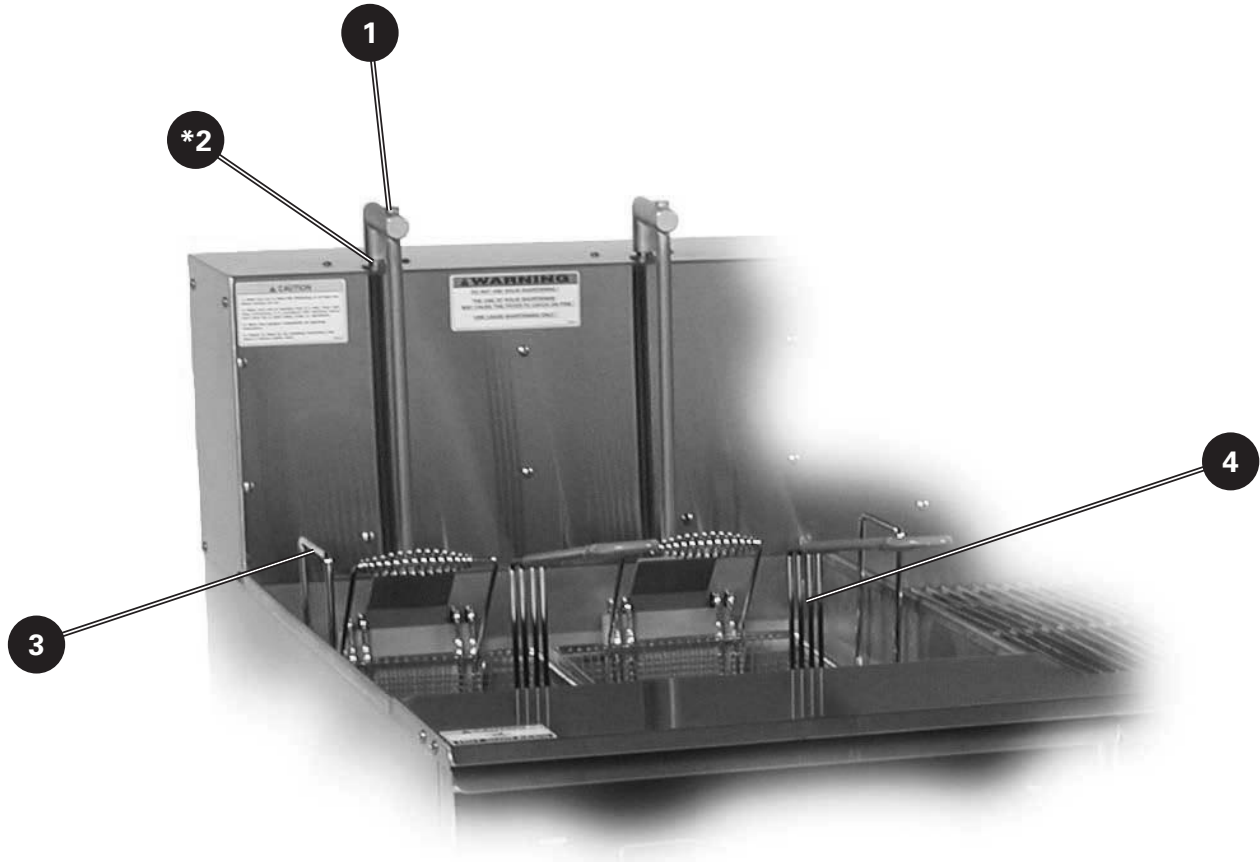

Overview

EOF-10-10/FFLT/24, EOF-10-10/FFLT/24/24
EOF-20/FFLT/24, EOF-20/FFLT/24/24

 **CAUTION**

- Always use Oven Mitts when using any of these parts. Parts will become very hot during normal use.

3-04. Basket Elevator (Optional) and Baskets

| Item | Description | Function |
|------|--------------------|---|
| 1 | Basket Carrier (2) | Used to hold the basket in the correct position when the basket is lifted or lower by the elevator. |
| 2 | Elevator (2) | LowerS and lifts basket from the Fry Pot. |
| 3 | Crumb Screen | Positioned just above elements to prevent excessive breading or product crumbs from accumulating near the Heating Elements. |
| 4 | Basket (2) | Used for cooking product. |

3-05. EOF-20 Control Panel



3-05. EOF-20 Control Panel

| Item | Description | Function |
|------|-----------------------|--|
| 1 | Power Switch | The Power Switch is used to turn power ON or OFF to the unit. |
| 2 | Heat Switch | The Heat Switch is used to turn power to elements ON and OFF. Place the Heat Switch in the OFF position when programming the controller or shutting down the unit. Place in ON position when ready to heat the oil. |
| 3 | Controller | The Electronic Controller is used for setting a cooking temperature and cooking times. |
| 4 | High-Limit Indicator | The Red High-Limit Light indicates an alarm condition. It is illuminated when power is shut-off to the heating elements by the overheat safety shutdown control circuit. Should this light come on during operation, refer to the Troubleshooting, Section 7, of this manual. COOKING ACTIVITIES SHOULD BE DISCONTINUED UNTIL CAUSE IS DETERMINED! |
| 5 | Heat Indicator Light | The Orange Heat Indicator Light is illuminated when the Heat Switch is in the ON position and the heating elements are energized. The light is off during intervals when oil is at setpoint and elements are de-energized. |
| 6 | Power Indicator Light | The Green Power Light is illuminated whenever the fryer's Power Switch is in the ON position. |
| 7 | Elevator Switch | The Elevator Switch is used activate or deactivate the Basket Lifts. If the switch is ON the Lift will lower when a cooking cycle starts and rise when a cooking cycle ends. If the switch is OFF the Basket Lifts will not operate. (This switch controls both left and right basket lifts) |

3-06. EOF-20 Lower Cabinet Area



3-06. EOF-20 Lower Cabinet Area

| Item | Description | Function |
|------|------------------------|--|
| 1 | Drain Valve Handle | <p>Used to drain the Fry Pot. Always ensure the Handle is closed and locked prior to adding cooking oil or boil out solution. Your fryer will not heat if this Drain Valve Handle is not completely closed and locked.</p> <p>⚠ DANGER</p> <p>ALWAYS ENSURE THE HEAT SWITCH IS IN THE OFF POSITION BEFORE OPENING THIS VALVE. FAILURE TO COMPLY WITH THIS DANGER NOTICE COULD RESULT IN A FIRE, CAUSING DEATH OR SERIOUS INJURY AND/OR EQUIPMENT/PROPERTY DAMAGE AND VOID THE WARRANTY.</p> <p>⚠ WARNING</p> <p>NEVER DRAIN OIL INTO THE FILTER PAN FROM MORE THAN ONE FRY POT AT A TIME. DOING SO WILL CAUSE THE FILTER PAN TO OVERFLOW. ALWAYS PUMP OIL FROM THE FILTER PAN BACK TO A FRY POT OR TO A DISPOSAL TANK BEFORE DRAINING ANOTHER FRY POT.</p> |
| 2 | Pump Oil Return Handle | Used when Filtering to return oil to the Fry Vat. |

3-07. FFLT Table

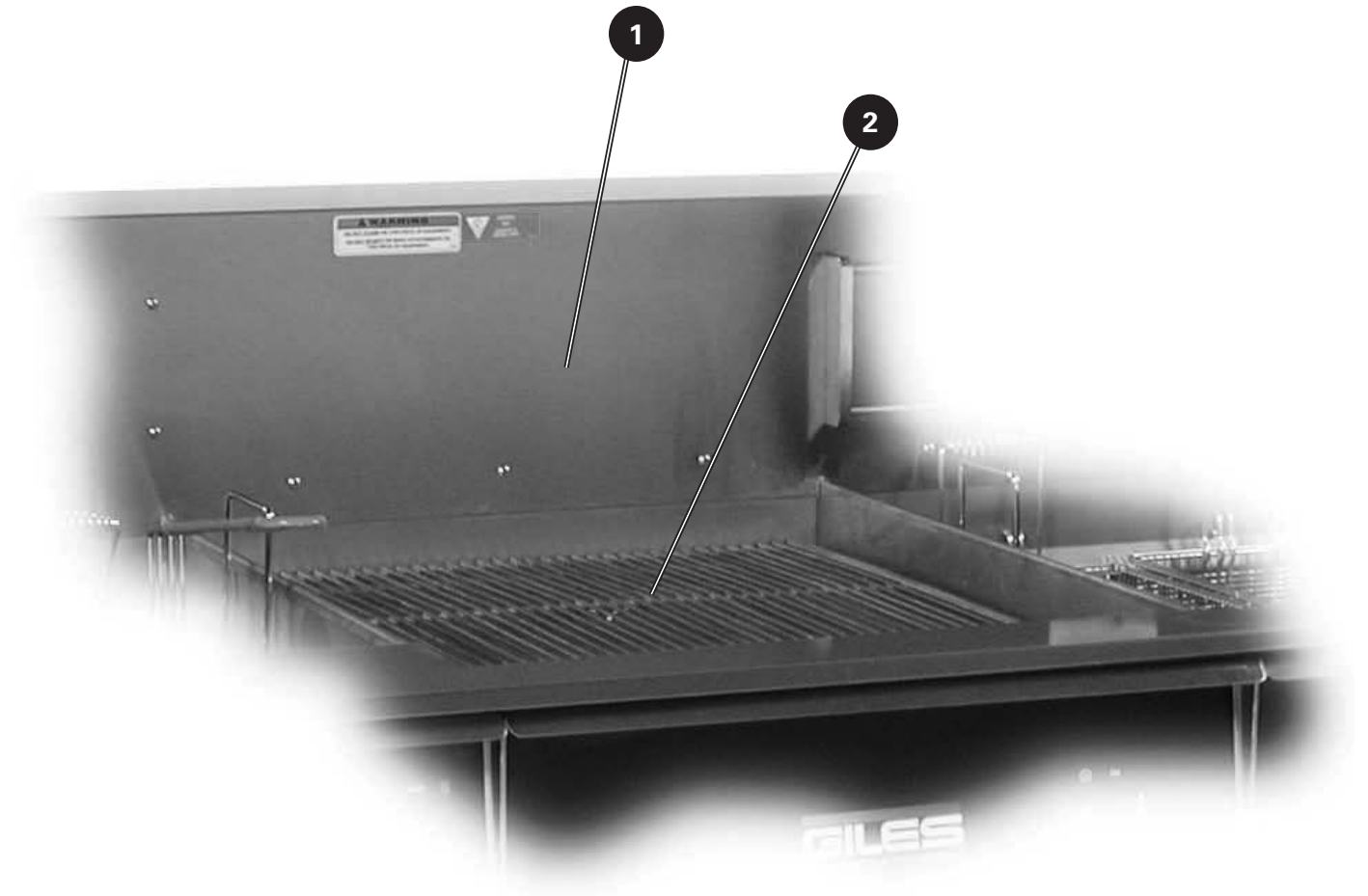

Overview

EOF-10-10/FFLT/24, EOF-10-10/FFLT/24/24
EOF-20/FFLT/24, EOF-20/FFLT/24/24



⚠ CAUTION

- Always use Oven Mitts when using any of these parts. Parts will become very hot during normal use.

3-07. Landing Table

| Item | Description | Function |
|------|----------------------|--|
| 1 | Landing Table | Dump area for cooked product. |
| 2 | Landing Table Screen | Allow excess oil to drain from the freshly cooked product. |

3-08. FFLT Control Panel



Overview

EOF-10-10/FFLT/24, EOF-10-10/FFLT/24/24
EOF-20/FFLT/24, EOF-20/FFLT/24/24

3-08. FFLT Control Panel

| Item | Description | Function |
|------|-------------|---|
| 1 | Pump Switch | Turns the Filter Pump ON or OFF to circulate oil through the oil filtration system and return it back to a selected Fry Vat, or pump oil from the Filter Pan, through the Oil Discharge Hose to an appropriate oil disposal unit. |

3-09. FFLT Lower Cabinet Area

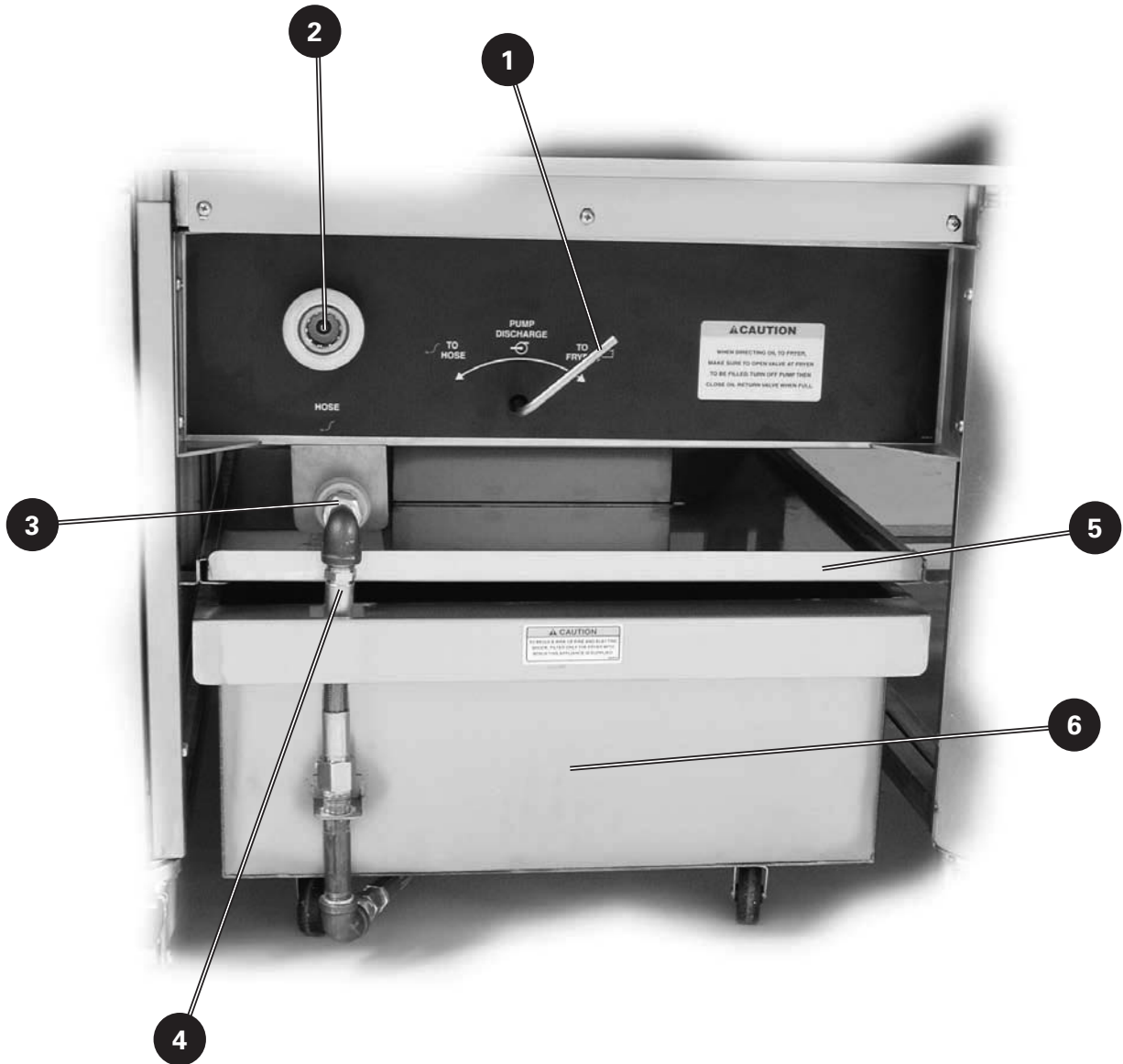



⚠ WARNING

- **Never remove the Filter Pan while it contains Liquid Shortening. This could result in oil spillage or possible burn injury. Please see Section 5-4. Removal of Liquid Shortening.**

⚠ CAUTION

- **Always use Oven Mitts when handling any of these parts. Parts become very hot during normal use.**
- **Never drain Boil Out Solution into the Filter Pan. Boil Out Solution is corrosive and will damage the Filter Pan, Filter Pan components and Filter Pump. See Section 6-1. Boil Out**

3-09. FFLT Lower Cabinet Area

| Item | Description | Function |
|------|---|--|
| 1 | Diverter Valve Handle | Used to direct pumped cooking oil from the Filter Pan to the Fry Pot or to the Cooking Oil Discharge Hose. |
| 2 | Quick Disconnect for Oil Discharge Wand | Connection fitting for the Oil Discharge Hose when removing oil from the fryer. |
| 3 | Quick Disconnect for Filter Pan Hose | Fitting for connecting the Filter Pan quick-disconnect hose to the fryer's oil filtration system. |
| 4 | Filter Pan Quick Disconnect Hose | See Section 3-8. |
| 5 | Filter Pan Cover | Helps prevent possibility of foreign material contamination of cooking oil during filtering operations. |
| 6 | Filter Pan | See Section 3-8. |

3-10. EOF-24 Basket Hanger and Baskets

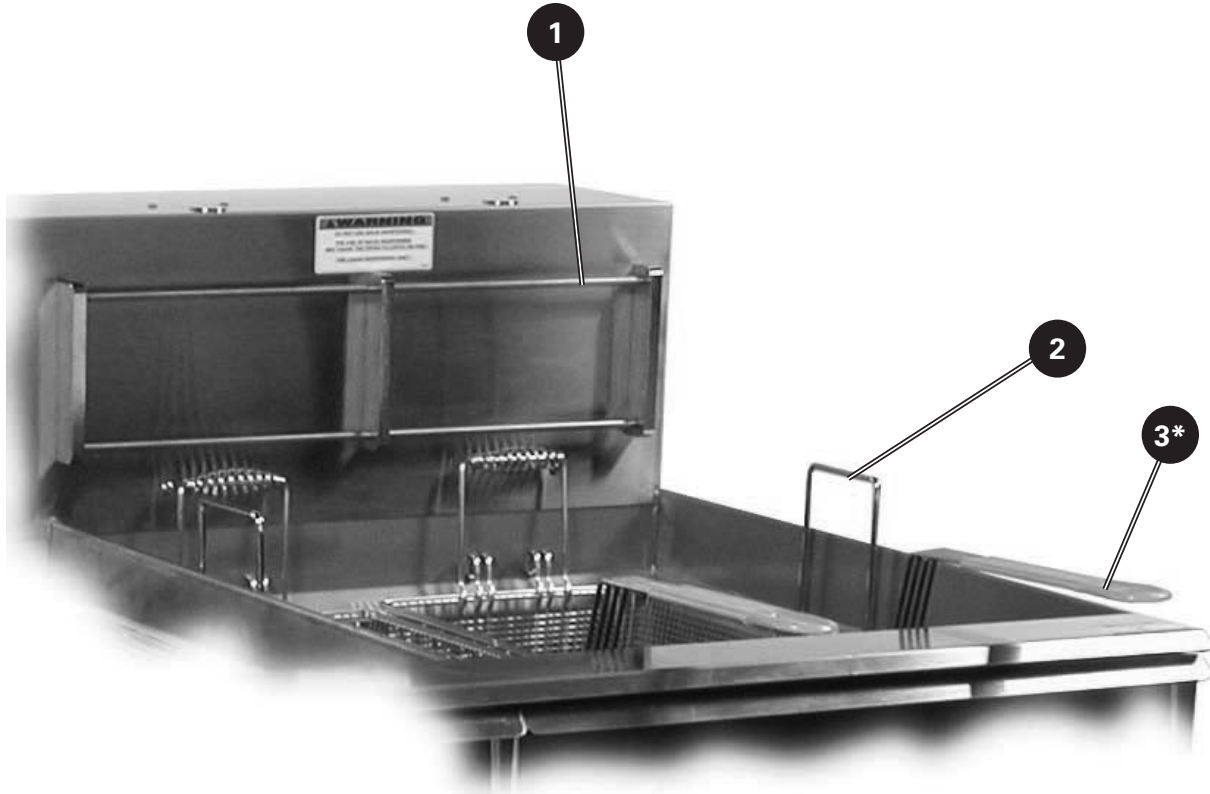

* Optional, not included as standard

Overview

EOF-10-10/FFLT/24, EOF-10-10/FFLT/24/24
EOF-20/FFLT/24, EOF-20/FFLT/24/24

CAUTION

- Always use Oven Mitts when using any of these parts. Parts will become very hot during normal use.

3-10. EOF-24 Basket Hanger and Baskets

| Item | Description | Function |
|------|---------------|---|
| 1 | Basket Hanger | Used to hold basket(s) allowing excess oil to drain from cooked product. |
| 2 | Crumb Screen | Positioned just above elements to prevent excessive breading or product crumbs from accumulating near the Heating Elements. |
| 3 | Basket (2) | Used for cooking product. (Optional item, not included as standard) |

3-11. EOF-24 Control Panel



3-11. EOF-24 Control Panel

| Item | Description | Function |
|------|-----------------------|---|
| 1 | Power Switch | The Power Switch is used to turn power ON or OFF to the unit. |
| 2 | Heat Switch | The Heat Switch is used to turn power to elements ON and OFF. Place the Heat Switch in the OFF position when programming the controller or shutting down the unit. Place in ON position when ready to heat the oil. |
| 3 | Controller | The Electronic Controller is used for setting a cooking temperature and cooking times. |
| 4 | High-Limit Indicator | The Red High-Limit Light indicates an alarm condition. It is illuminated when power is shut-off to the heating elements by the overheat safety shutdown control circuit. Should this light come on during operation, refer to the Troubleshooting, Section 7, of this manual. COOKING ACTIVITIES SHOULD BE DISCONTINUED UNTIL CAUSE IS DETERMINED! |
| 5 | Heat Indicator Light | The Orange Heat Indicator Light is illuminated when the Heat Switch is in the ON position and the heating elements are energized. The light is off during intervals when oil is at setpoint and elements are de-energized. |
| 6 | Power Indicator Light | The Green Power Light is on whenever the fryer's Power Switch is in the ON position. |

3-12. EOF-24 Lower Cabinet Area



3-12. EOF-24 Control Panel

| Item | Description | Function |
|------|------------------------|--|
| 1 | Drain Valve Handle | <p>Used to drain the Fry Pot. Always ensure the valve is closed and locked prior to adding cooking oil or boil out solution. Your fryer will not heat if this drain valve is not completely closed and locked.</p> <p>⚠ DANGER</p> <p>ALWAYS ENSURE THE HEAT SWITCH IS IN THE OFF POSITION BEFORE OPENING THIS VALVE. FAILURE TO COMPLY WITH THIS DANGER NOTICE COULD RESULT IN A FIRE, CAUSING DEATH OR SERIOUS INJURY AND/OR EQUIPMENT/PROPERTY DAMAGE AND VOID THE WARRANTY.</p> <p>⚠ WARNING</p> <p>NEVER DRAIN OIL INTO THE FILTER PAN FROM MORE THAN ONE FRY POT AT A TIME. DOING SO WILL CAUSE THE FILTER PAN TO OVERFLOW. ALWAYS PUMP OIL FROM THE FILTER PAN BACK TO A FRY POT OR TO A DISPOSAL TANK BEFORE DRAINING ANOTHER FRY POT.</p> |
| 2 | Pump Oil Return Handle | Used when Filtering to return oil to the Fry Vat. |

3-13. Filter Pan Assembly

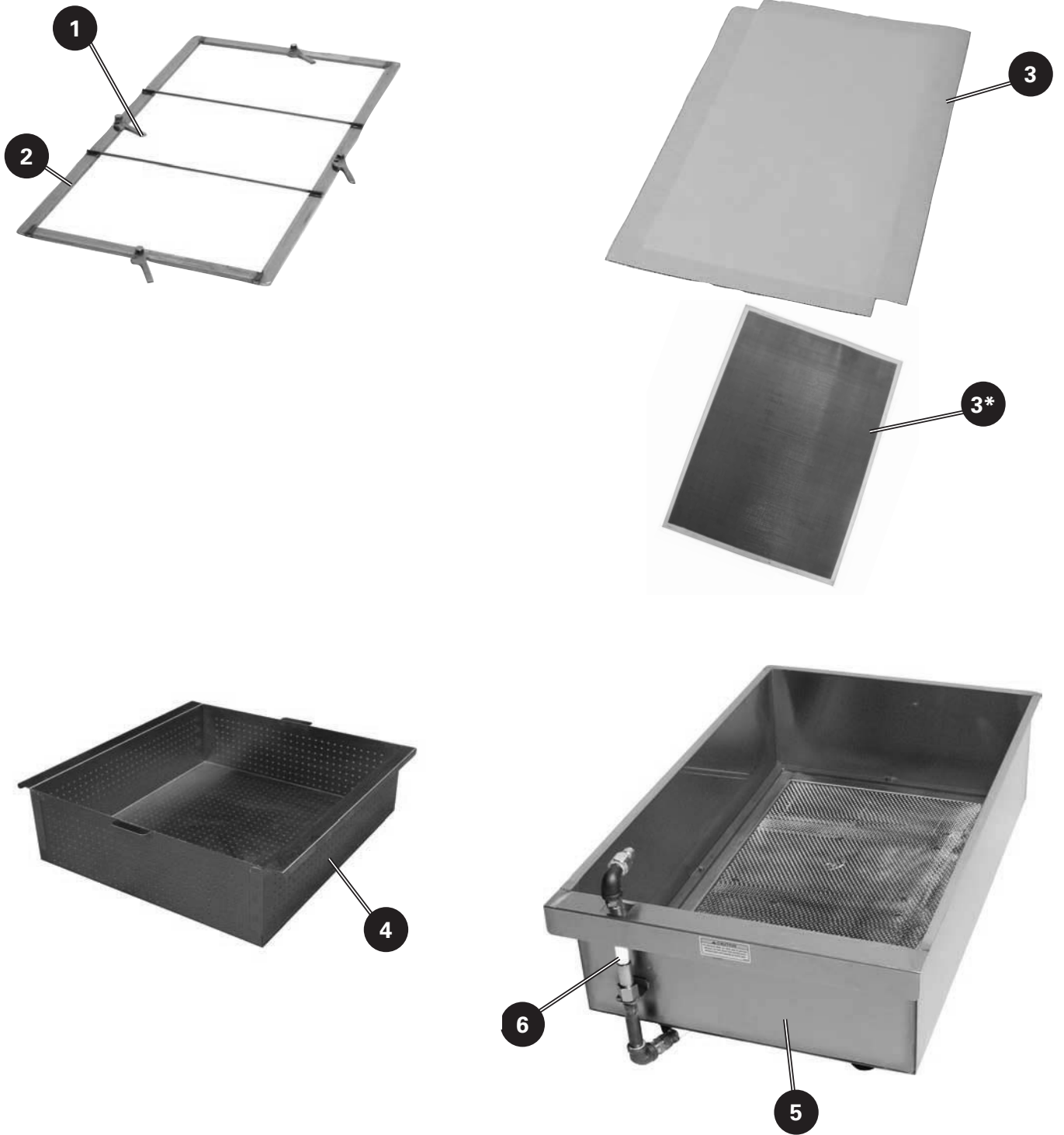



⚠ WARNING





- **Never remove the Filter Pan while it contains Liquid Shortening. This could result in oil spillage or possible burn injury. Please see Section 5-4. Removal of Liquid Shortening.**

⚠ CAUTION

- **Always use Oven Mitts when using any of these parts. Parts will become very hot during normal use.**

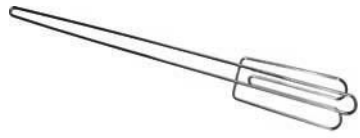

3-13. Filter Pan Assembly





| Item | Description | Function |
|------|---------------------------------|--|
| 1 | Hold Down Lever (4 Levers) | Locks & tightly holds the hold-down frame, sealing the filter paper against the pan bottom. |
| 2 | Hold Down Frame | Holds & seal the filter paper against the pan bottom. |
| 3 | Filter Paper | Filters finer particles of sediment from the cooking oil. The system requires at least (1) piece of Filter Paper, (2) may be used. |
| 3* | Optional Filter Media (SSFS) | Renewable, Stainless Steel Filter Screen. Optional alternative for Filter Paper. Can be cleaned and reused many times. |
| 4 | Filter Pan Crumb Screen | Captures large crumbs & particles of sediment as oil is drained into Filter Pan, providing an additional component of the filtering process. |
| 5 | Filter Pan | Filters cooking oil after every (4) cook cycles. The Filter Pan is easily removable for cleaning and filter paper changes. It features casters for portability. A permanent perforated screen is affixed to the pan bottom to support the filter paper and aid in protecting the filter pump from unintended debris. IT IS NOT A FILTER - FILTER PAPER MUST BE USED. |
| 6 | Filter Pan Quick-disconnect | Fitting for connection to the fryer's oil filtration system. Hose must be disconnected before removing the filter pan. |

| 3-14. Accessories (Included) | | |
|---|-----------------------------------|---|
| Part | Description/Part Number | Function |
|  | Kettle Drain Brush P/N: 71025 | Used for cleaning the Fry Pot. |
|  | Drain Brush, Small P/N: 73235 | Used for cleaning the FFLT drain |
|  | Stir Paddle P/N: 77775 | Used for stirring Hot Oil and Product being cooked. |
|  | Fry Vat Clean Brush P/N: 71100 | Used for cleaning Fry Pot and Elements. |
|  | Crumb Shovel P/N: 30059 | Used for removing sediment from the Filter Pan. |

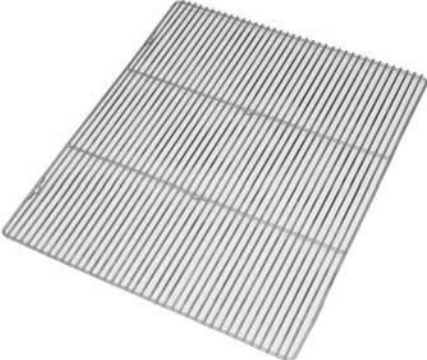

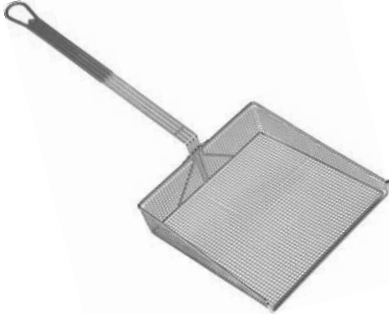
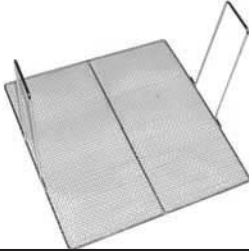
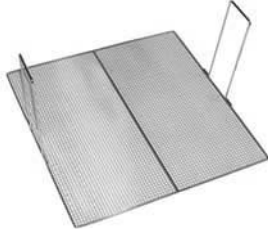

Overview

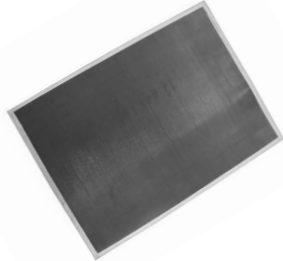

EOF-10-10/FFLT/24, EOF-10-10/FFLT/24/24
 EOF-20/FFLT/24, EOF-20/FFLT/24/24

| 3-14. Accessories (Included) | | |
|---|-----------------------------------|--|
| Part | Description/Part Number | Function |
|  | L- Shaped Brush P/N: 73233 | Used for cleaning between elements. |
|  | Vat Drain Clean Out P/N: 36577 | Used to clear excessive sediment build up from the Vat Drain. |
|  | Wand Hose P/N: 33667 | Used for removing liquid shortening from unit. Note: Not intended for washing down the fry vat. |
|  | FFLT Drain Screen P/N: 70085 | Used to allow excess oil to drain from freshly cooked product. |

| 3-14. Accessories (Included) | | |
|---|--|--|
| Part | Description/Part Number | Function |
|  | (1) EOF-20 Fry Basket (Blue Handle) P/N: 70420 | Used for cooking product in the EOF-10-10 or the EOF-20. |
|  | (1) EOF-20 Fry Basket (Yellow Handle) P/N: 71109 | Used for cooking product in the EOF-10-10 or the EOF-20. |
|  | Scoop Basket P/N: 70430 | Used for removing cooked product when batch cooking without using Fry Baskets. |
|  | EOF-20 Fry Screen P/N: 70083 | Used to prevent excess breading or product from contacting the Heating Elements. |
|  | EOF-24 Fry Screen P/N: 70084 | Used to prevent excess breading or product from contacting the Heating Elements. |
|  | (2) EOF-10-10 Fry Screen P/N: 71110 | Used to prevent excess breading or product from contacting the Heating Elements. |

3-15. Accessories (Not Included)

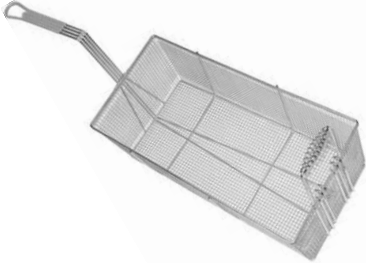
| Part | Description/Part Number | Function |
|---|--|--|
|  | Stainless Steel Filter Screen (SSFS) P/N: 41017 | Renewable, reusable filter media; direct replacement for Filter Paper. Can be cleaned and reused many times. |
|  | Filter Paper P/N: 60328 | Used to filter the cooking oil. |
|  | Filter Powder P/N: 72004 | Used to help clean the cooking oil. |
|  | Fryer Boil-Out P/N: 72003 | Used to help clean the fry pot. |

| 3-15. Accessories (Not Included) | | |
|---|---|--|
| Part | Description/Part Number | Function |
|  | <p>EOF-24 Fry Basket P/N: 70421</p> | <p>Sized for use in the 24" Vat to cook product.</p> |
|  | <p>Fryer Tool Caddy/Splash Guard</p> <p>Left-Side: P/N 71523 Right-Side: P/N 71524</p> <p>(Tools come standard with Fryer or sold separately)</p> | <p>Dual purpose Fryer attachment (no tools required)</p> <p>Store and organize Fryer Tools right at the fryer.</p> <p>Acts as Splash Guard to keep oil splatter or splash off the floor or adjacent equipment.</p> |
|  | <p>Giles Oil Caddy P/N: 79187</p> | <p>A portable oil disposal container with a capacity of 80lbs of liquid shortening.</p> <p>Note: For use with filtered, warm oil only. No crumbs or debris.</p> |

4. Unit Preparation

Giles Enterprises takes pride in the quality of its workmanship. Every effort has been made to ensure that your unit is in good operating condition when received. Each unit must pass rigorous quality control testing prior to shipment. To further ensure optimum operation, a brief operational check-out of your new fryer must be conducted as described in this section.

CAUTION

- Before attempting to operate the unit, refer to Section 3 to familiarize yourself with the various control functions. Once you have read and fully understand Section 3, please follow the steps below precisely in order to prevent equipment damage or malfunction.

4-01. Settings before each test

Please ensure each unit's control panel and valves are set to the following before proceeding to each test.

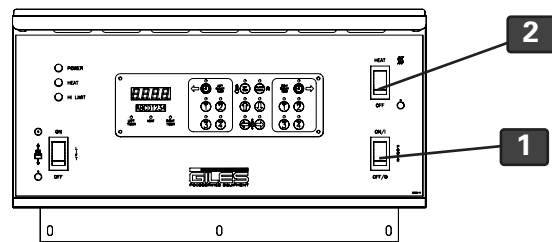

EOF-20 or EOF-24

1. Power Switch is in the OFF **1** position.
2. Heat Switch is in the OFF **2** position.

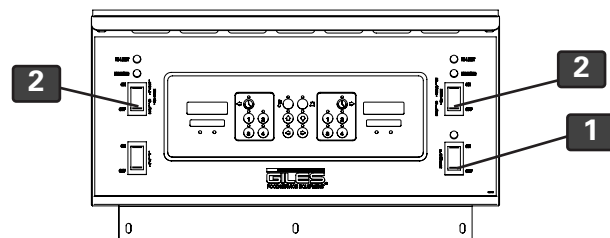

EOF-10-10

4-01. Settings before each test (Continued from previous page)

3. Open the FFLT Cabinet Door and remove the Filter Pan.
4. Ensure the Drain Valve Handle on each unit is in the CLOSED and Locked **3** position (tab pushed thru opening & tucked behind panel).
5. Ensure the Oil Diverter Valve is in the TO FRYER **4** position.
6. Remove Crumb Screen(s) and Baskets.

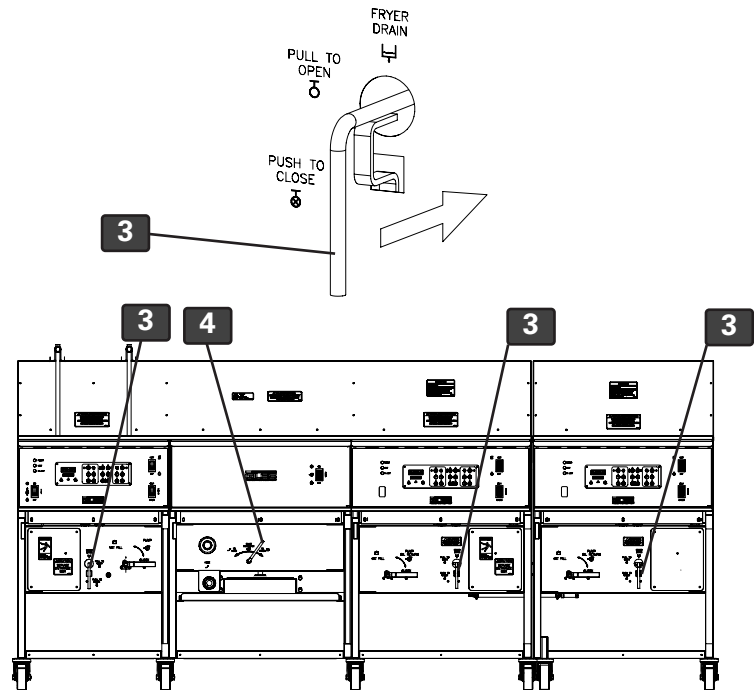

EOF-20/FFLT/24 or EOF-20/FFLT/24/24

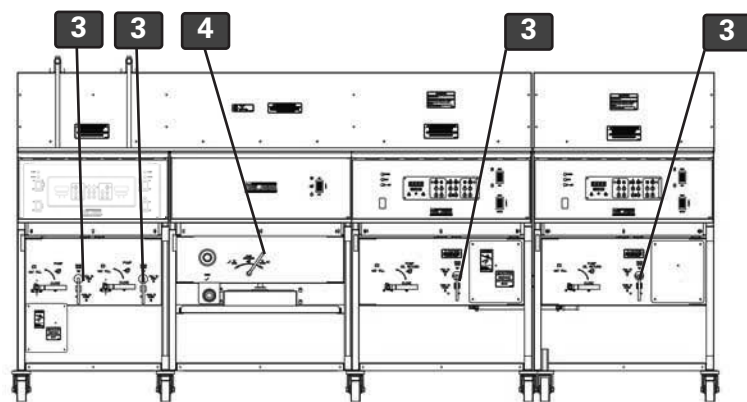

EOF-10-10/FFLT/24 or EOF-10-10/FFLT/24/24

Unit Preparation

EOF-10-10/FFLT/24, EOF-10-10/FFLT/24/24
EOF-20/FFLT/24, EOF-20/FFLT/24/24

4-02. Power test

The following test will ensure the unit has power. Perform test on each unit.

1. Follow steps shown in Section 4-1.
2. Ensure the main circuit breaker supplying power the unit is ON. If a Disconnect Box is used, ensure it is ON.
3. Press the Power Switch to the ON **1** position. The green POWER light **2** will illuminate. Please proceed to Section 4-3.

If the POWER light does not come on, refer to the Troubleshooting procedure in Section 7-1.

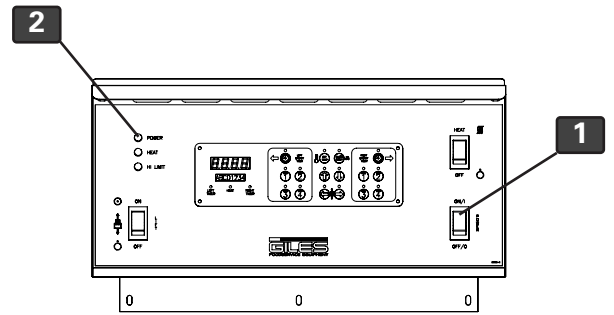

EOF-20 or EOF-24

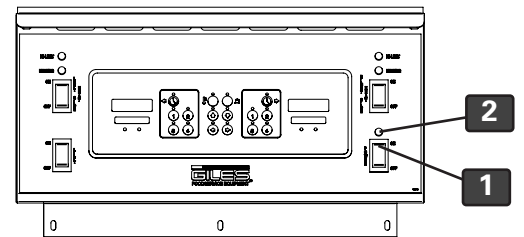

EOF-10-10

4-03. Heating Element test

The following test will ensure the Heating Element is being powered. **Perform this test on each Fry Pot.**

⚠ DANGER

•**DO NOT touch the Heating Elements. The Heating Elements are very hot and skin contact with the Heating Elements may result in severe burns.**

1. Follow steps shown in Section 4-1.
2. Ensure Power Switch is in the OFF position.
3. Liberally dampen a sponge with water and wipe down the Heating Element **1**.
4. Press the Power Switch to the ON **2** position.
5. Wait until the Controller display **3** reads "HOLD."
- 6.a. **For the EOF-20 or EOF-24 only**, press the Set Temp **4** button, the display should read 350. If not, set the temperature to 350, see Section 5-1.2. Programming the Cooking Temperature.
- 6.b. **For the EOF-10-10 only**, press the left or right arrow **5** button to select the left or right cooking vat, then press the Set Temp **6** button, the display should read 350. If not, set the temperature to 350, see Section 5-1.2. Programming the Cooking Temperature.
7. Press the Heat Switch to the HEAT **7** position. Leave in the HEAT position **NO MORE THAN 10 SECONDS.**
 Note: Should the Controller Scrolling Display **8** read "Check Oil Level," press the Power Switch **9** to the OFF position and proceed to the next step.

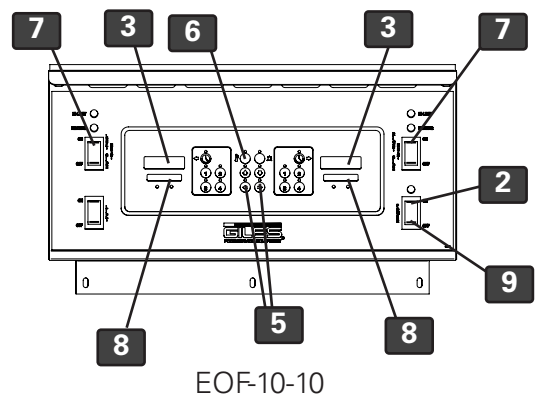
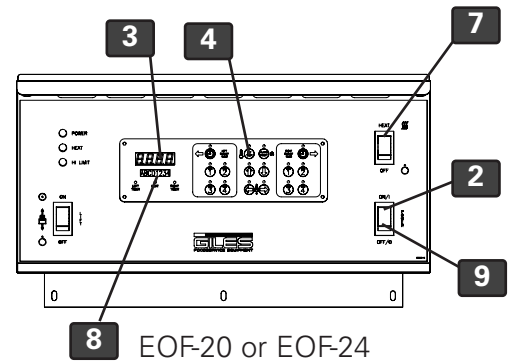
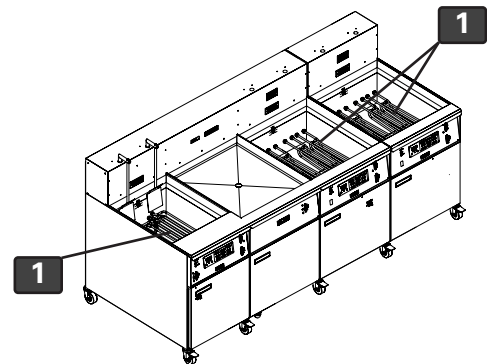

Continued next page

4-03. Heating Element test (Continued from previous page)

8. Press the Heat Switch **10** to the OFF position
9. The wet element should dry quickly dry, approximately 15 seconds. Proceed to Section 4-4.

If the Heating Element does not dry within 15-30 seconds, refer to the Troubleshooting procedure in Section 7-1.

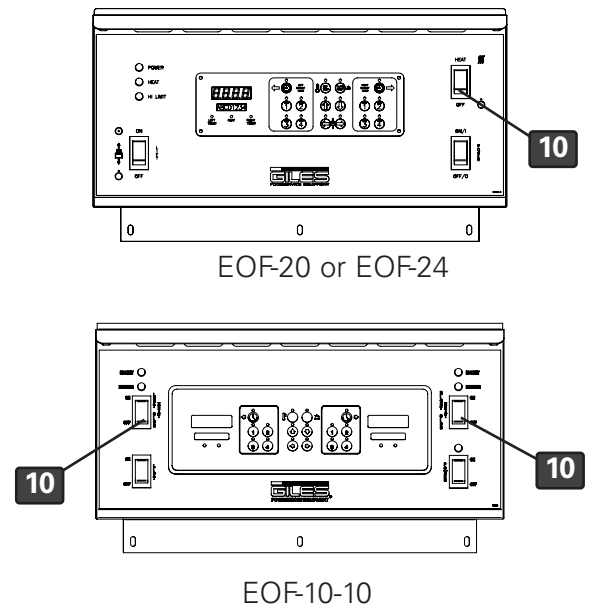

4-04. Filter Pump Test

The following test will ensure the Filter Pump is operating correctly.

1. Follow steps shown in Section 4-1.
2. Open Landing Table (FFLT) Cabinet Door.
3. Place the palm of your hand over the Quick Disconnect **1** for the Filter Pan connection.
4. Briefly press the Pump Switch **2** to the PUMP position and then return it to the OFF **3** position. If suction is felt on the palm, the pump is operating correctly. Proceed to Section 4.5.

If no suction is detected, refer to the Troubleshooting procedure in Section 7-2.

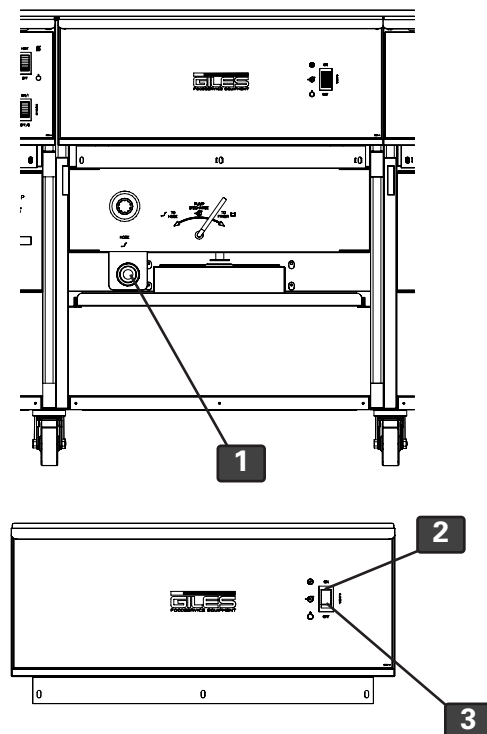

4-05. Perform Boil Out Procedure

Perform a Boil Out Procedure to remove any dirt, dust or debris that may have accumulated during shipping. Follow Section 6-1 Boil Out Procedure. After performing the Boil Out Procedure proceed to Section 4-6.

4-06. Clean Filter Pan

Thoroughly clean the Filter Pan to remove any dirt, dust or debris that may have accumulated during shipping. Follow Section 6-2 Cleaning the Filter Pan and replacing Filter Paper after Boil Out.

Fryer preparation is now complete; proceed to the Fryer Operation Section.

5. Fryer Operation

This section describes how to operate the unit.

DANGER

- Turn off the unit and turn off the fryer's circuit breaker in the main circuit breaker box before cleaning or performing maintenance.
- DO NOT hose down the unit's interior or exterior with water.
- Failure to comply with these DANGER notices will result in death or serious injury, equipment/property damage, and void the warranty.

CAUTION

- Ensure the unit is positioned in a secure, safe location ... casters with brakes must have the brake applied.
- Consult an electrician to ensure all electrical specifications have been met and the unit is properly grounded. The wiring diagrams provided with this unit should aid the electrician while installing the fryer.
- Due to the high temperature of oil during cooking operations, it is extremely important that the user exercise caution when working with or around this equipment to avoid personal injury.

5-01. Cooking Controller

The following section describes the functions, features and programming of the Cooking Controller.

EOF-10-10

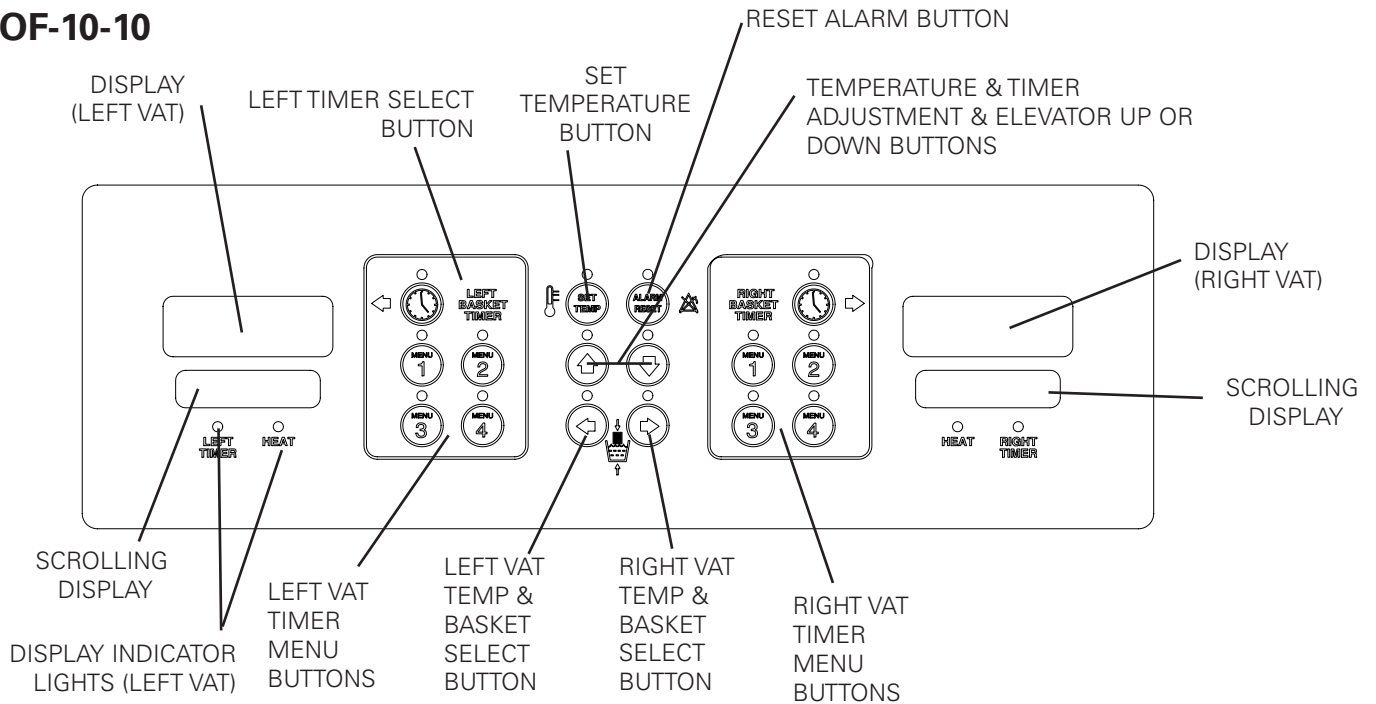

EOF-20 or EOF-24

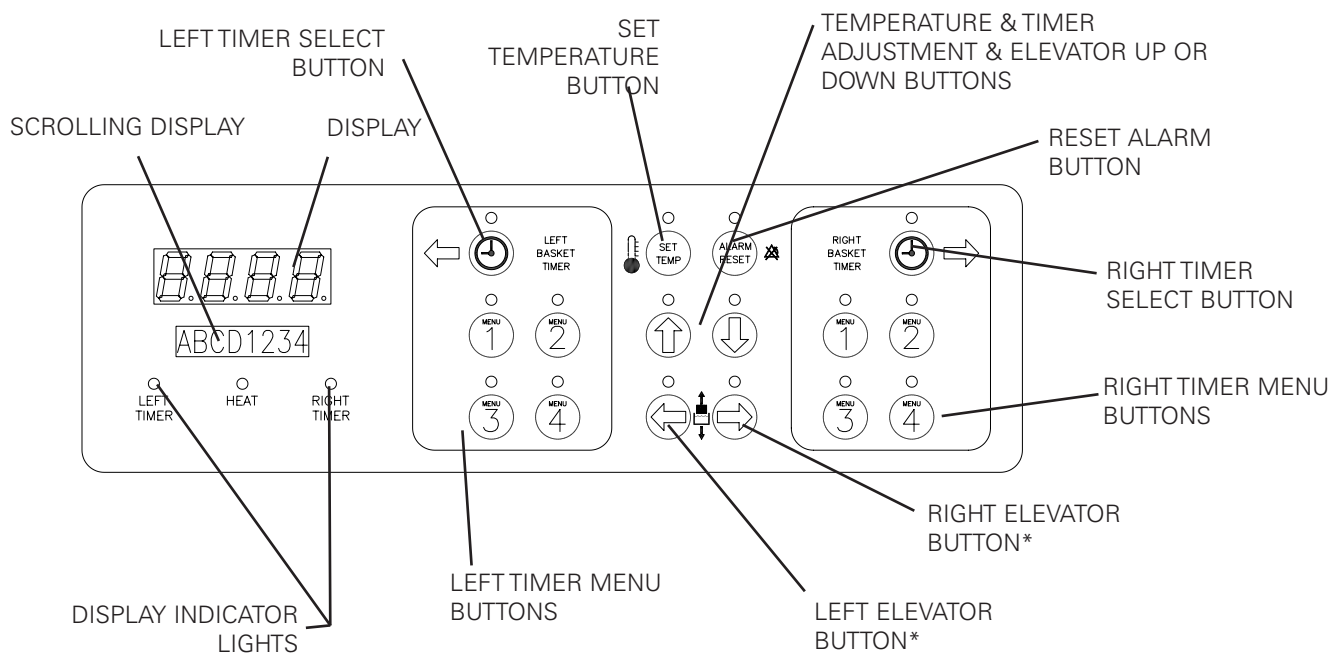

* -Basket Elevator Option Only

5-01.1. Buttons and Functions

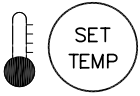

Used to set and display cooking temperature.

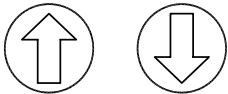

Used to increase or decrease cooking time and temperature.

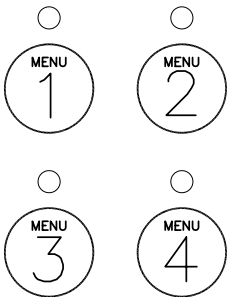

Used to set and recall cooking times.



Used to silence alarm.

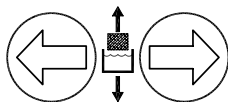

EOF-10-10: Used to select Left-Right Vat and Basket Elevator.

EOF-20 or EOF-24: Used to select Left or Right Basket Elevator. (Basket Elevator Option Only)

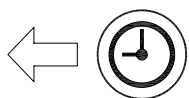

Used to select the Left Basket Timer.

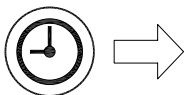

Used to select the Right Basket Timer.

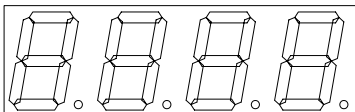

Used to display cooking times and temperature.



Scrolls various status information.

5-01.2. Programming the Cooking Temperature

EOF-10-10

Ensure both Heat Switches are in the OFF position

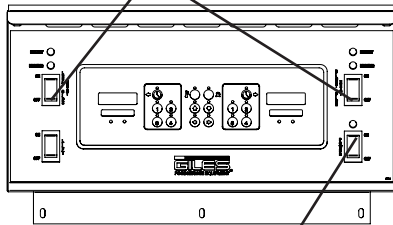

Press Power Switch to ON

Select left or right side to program

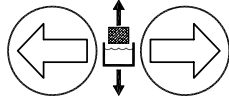

Press

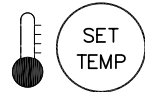

Adjust temperature

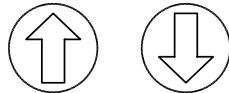

Press to set

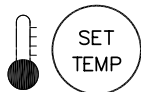

EOF-20 or EOF-24

Ensure Heat Switch is in the OFF position

Press Power Switch to ON

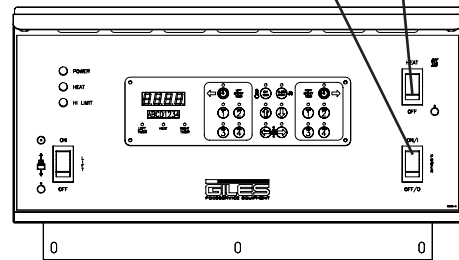

Press

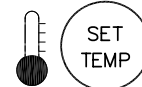

Adjust temperature

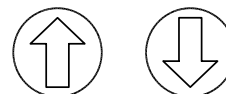

Press to set

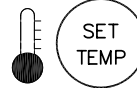

5-01.3. Programming a Cooking Time

EOF-10-10

Ensure both Heat Switches are in the OFF position

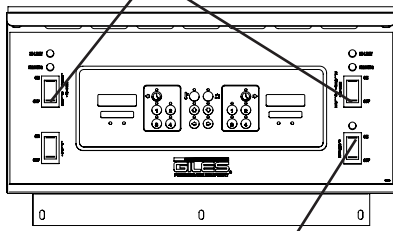

Press Power Switch to ON

EOF-20 or EOF-24

Ensure Heat Switch is in the OFF position

Press Power Switch to ON

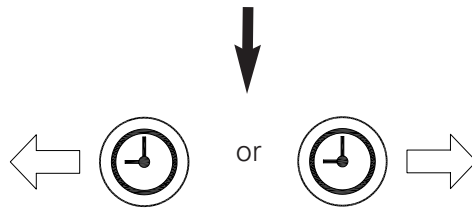
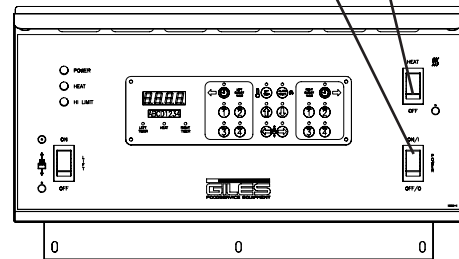

Press & hold both the desired Basket Timer Button (left or right) and the desired Menu # Key for 5 seconds

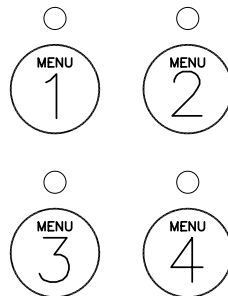

Press the desired Basket Timer Button again to set

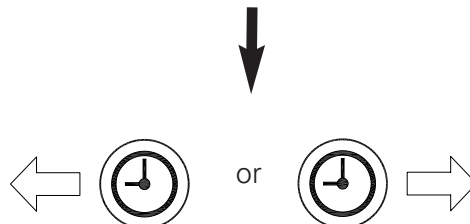

5-01.4. Start a cooking time

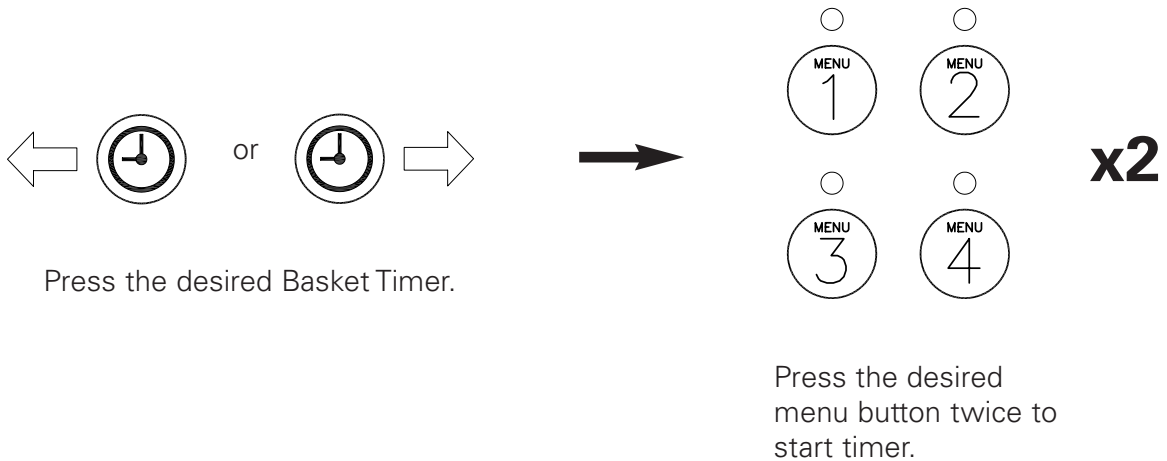

5-01.5. Cancel the currently running cooking time



(Basket Elevator Option Only) If cancelled after the Basket Lift has been lowered, the Lift will raise when the program is cancelled.

5-01.6. Manually lowering and raising the cooking basket (Basket Lift Only)



Fryer Operation

EOF-10-10/FFLT/24, EOF-10-10/FFLT/24/24
 EOF-20/FFLT/24, EOF-20/FFLT/24/24

5-01.7. Displaying remaining cooking time

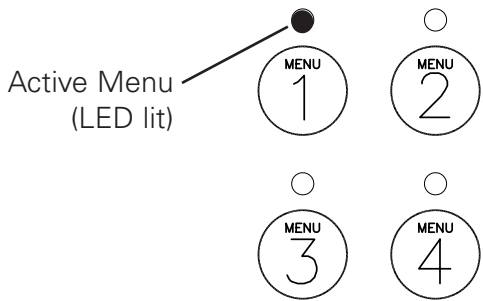

Press the active (LED lit) Timer Menu button

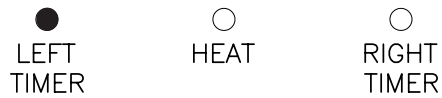

The time is displayed and the Left or Right LED is lit to identify the Basket time being displayed.

5-01.8. Displaying the actual temperature of the liquid shortening

EOF-10-10

Select left or right side

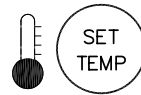
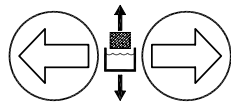

Press and Hold for 5 seconds

Actual temperature will display for 20 seconds

EOF-20 or EOF-24

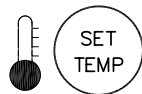

Press and Hold for 5 seconds

Actual temperature will display for 20 seconds

5-02. Cooking Procedure

This section describes the cooking process for the unit. This procedure applies to the EOF-20 and EOF-24 units.

1. Program the Controller to the desired temperature, See Section 5-1.2.
2. Ensure the Power Switch is in the OFF **1** position.
3. Ensure the Heat Switch is in the OFF **2** position.
4. Ensure the Drain Valve is pushed in and locked in the CLOSED **3** position (tab thru opening & tucked securely behind panel).
5. Fill the Fry Pot with liquid shortening to the ADD **4** level only. The Fry Pot is filled only to this level to allow for expansion of liquid shortening as it is heated.

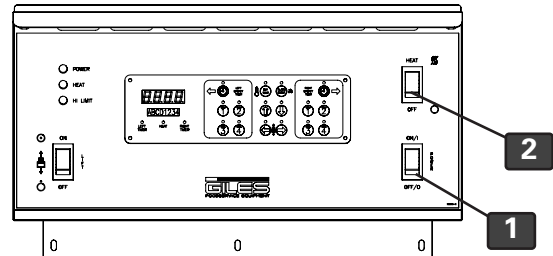

EOF-20 or EOF-24

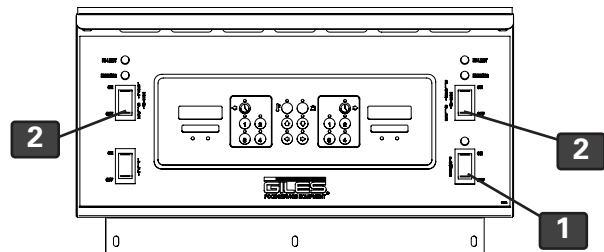

EOF-10-10

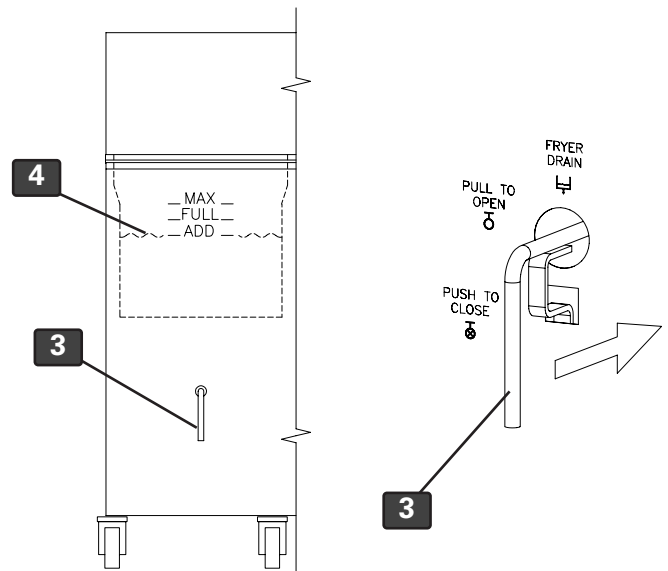

Continued next page

5-02. Cooking Procedure (Continued from previous page)

6. Press the Power Switch **5** to the ON position. The Power Light **6** will turn on. If the unit is equipped with the Basket Elevators and you wish to activate the lifts, place the Basket Elevator Switch **7** in the ON position.

NOTE:

- If an alarm sounds when Power Switch is placed in the ON position and the Scrolling Display reads "Drain Open - Close & Push Reset", follow step 4, above and then press Alarm Reset on the Cooking Controller.

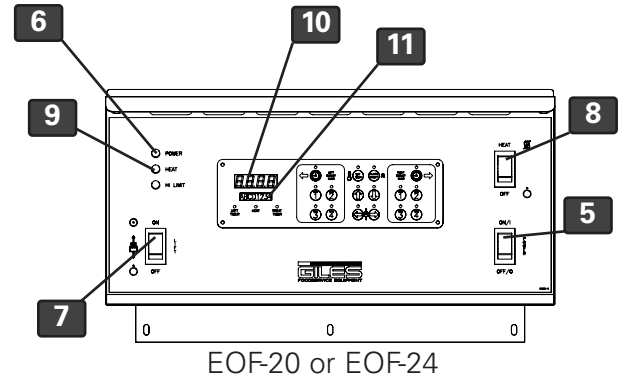

7. Press the HEAT Switch **8** to the ON position. The Heat Light **9** will illuminate, the display **10** will read "HOLD" and the Scrolling Display **11** will read "Oil Heating". Oil will begin to heat to the programmed setpoint temperature .

NOTE:

- On the first heating of the day, particularly if the cool shortening is in a thickened state, it is recommended that the vat be stirred occasionally during heating to prevent false Hi-Limit or Low Oil alarms.

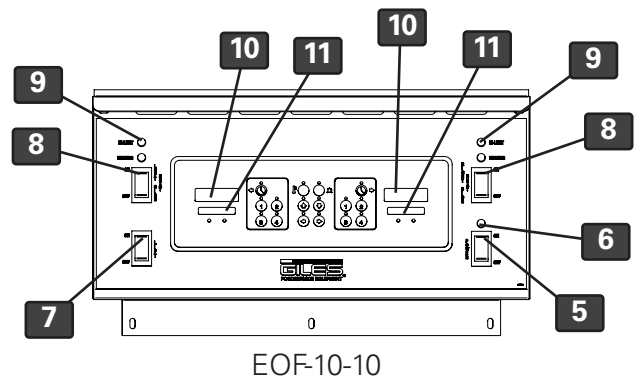

5-02. Cooking Procedure (Continued from previous page)

NOTE:

- The following step will help remove any cold areas in the heated Liquid Shortening which will allow the product to be cooked more evenly.

8. Once oil has reached the first preheat, an alarm will sound and the Scroll Display will read "Stir Oil and Push Reset" **11**. Using the supplied Stir Paddle, thoroughly stir the Cooking Oil, then press the Alarm Reset **12** button.

9. When the Heat Light **13** goes out the Oil has reach setpoint temperature.

10. Check the oil level, it should now be at the FULL Mark **14**. Add if needed.

11. Place the Fry Screen **15** into Fry Pot (handles to the sides).

12. (Basket Elevator Option Only) Place the Cooking Basket **16** onto the Basket Carrier **17**.

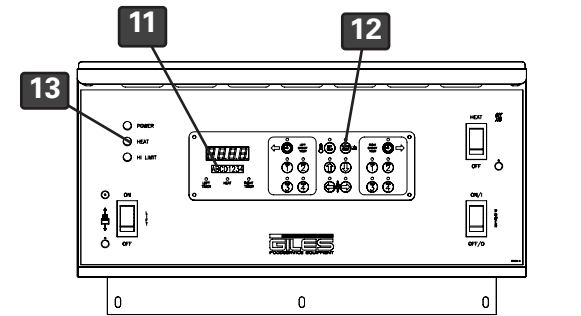

EOF-20 or EOF-24

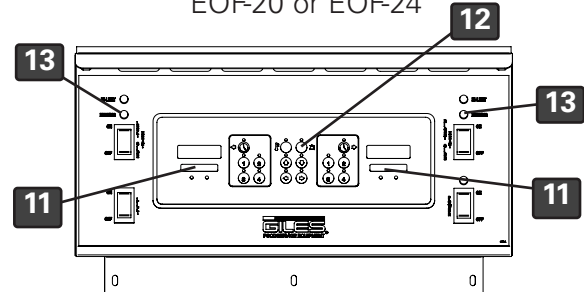

EOF-10-10

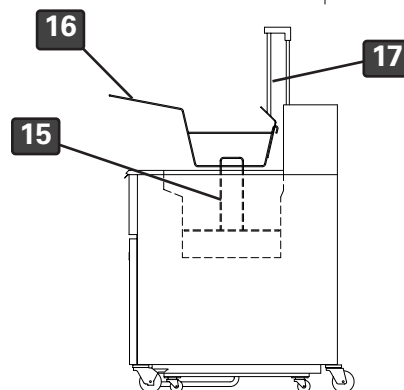
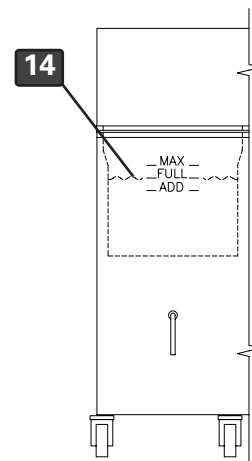

Continued next page

5-02. Cooking Procedure (Continued from previous page)

13. We recommend placing uncooked product into the Cook Basket while in the up position, then lowering the basket into the oil. However, uncooked product may be placed into the Cooking Basket after it has been lowered into the oil.

CAUTION

- Use extreme caution when placing product into the HOT shortening as severe burns are possible should hands contact hot oil or in the event of unexpected oil splash.

14. (Basket Elevator Option Only) Press the desired Basket Lift Button **18**. Then press the Down Arrow **19**. Cook Basket will lower.

(Basket Hanger Option Only) Place Baskets in Fry Pot, resting on Fry Screen **20**.

15. Press desired Basket Timer **21** Button, then press the desired Menu Time **22** Button two times. The the time will start counting down and the Scrolling Display will read "Cooking" **23**.

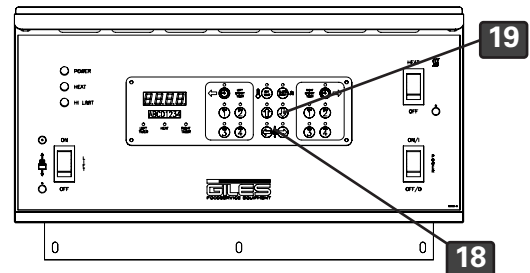

EOF-20 or EOF-24

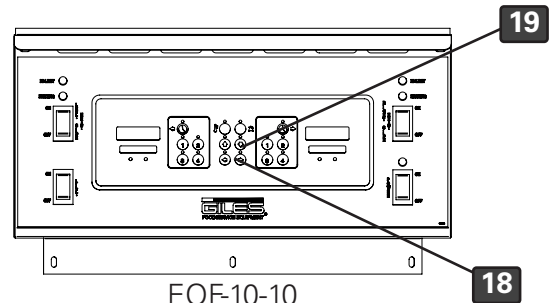

EOF-10-10

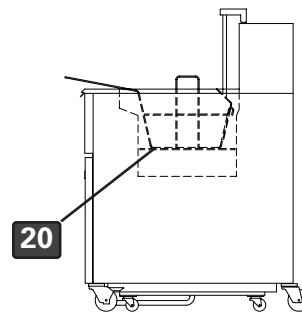

20

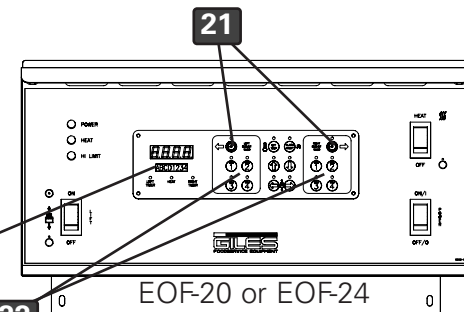

EOF-20 or EOF-24

23

22

21

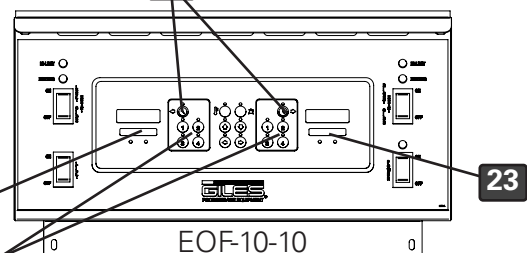

EOF-10-10

23

22

EOF-10-10

Continued next page

5-02. Cooking Procedure (Continued from previous page)

16. After 60% of the cooking time has elapsed from the selected cooking time, a Stir Cycle alarm will sound and the Scrolling Display will read "Stir Product" **24**. Using the Stir Paddle **25** and wearing oven mitts, stir the product and then press the Alarm Reset Button **26**.

17. **With Basket Elevators:** At the end of the programmed cooking time, an alarm will sound and the Display will read "DONE" **27**. The Scrolling Display will read "Left Timer" or "Right Timer" **24**. The Cook Basket **28** will automatically be raised from the oil. Press Alarm Reset Button **26** to silence the alarm.

With Manual Baskets: At the end of the programmed cooking time, an alarm will sound and the Display will read "DONE" **27**. The Scrolling Display will read "Left Timer" or "Right Timer" **24**. Using Oven Mitts lift the Basket **28** from the oil and hang it on the top bar of the Basket Hanger **29**. Press the Alarm Reset Button **26** to silence the alarm.

18. Allow cooked product to adequately drain.

19. Using Oven Mitts remove the Basket and dump cooked product onto the FFLT landing table or into an appropriate container.

20. • To continue cooking return to step 6 of this procedure.

• To shut-down the unit, see Section 5-5 Normal Shut-Down.

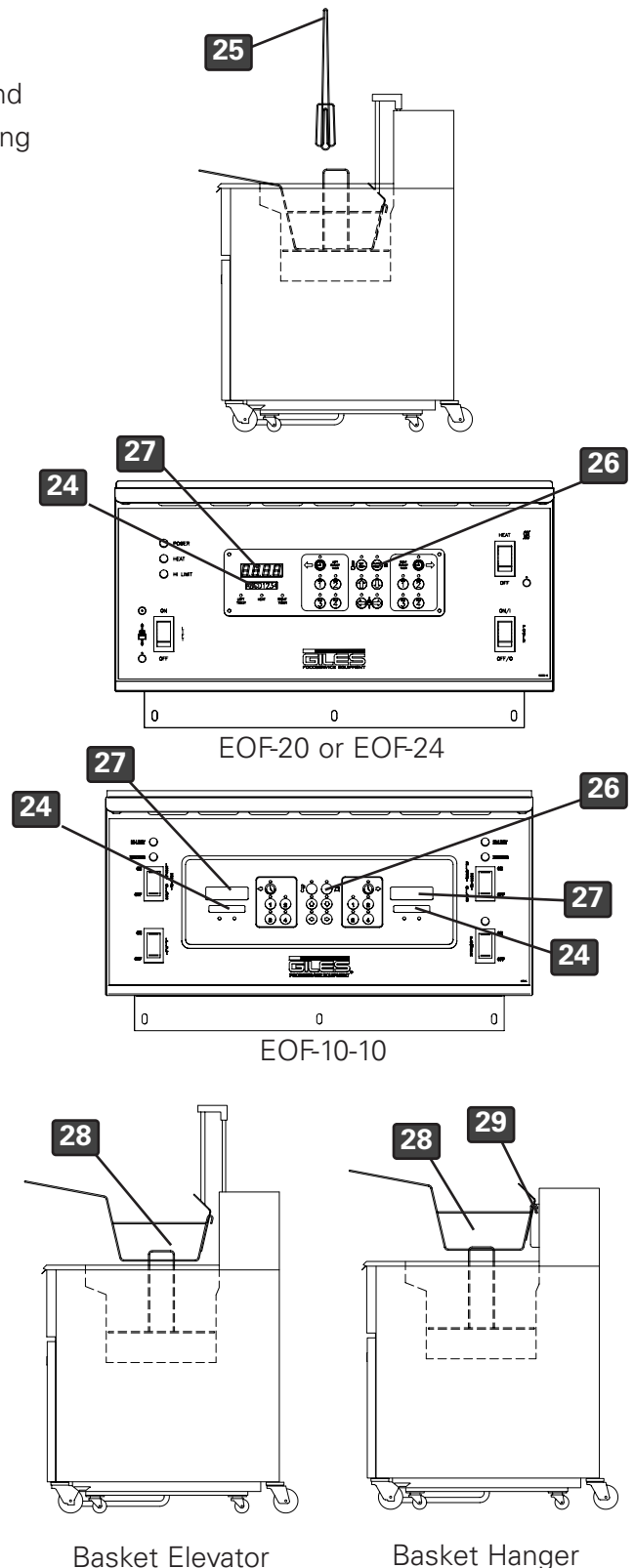

5-03. Filtering Fryer Shortening

This section describes the procedure for filtering the fryer shortening through the built-in filtration system. The filtration system circulates used cooking oil through filter media in the Filter Pan and back to the Cooking Vat. Adhering to this process can increase shortening life up to 50%. Cooking Controllers on each fry vat are preset to alert the operator to filter shortening after every fourth (4th) load cooked.

Two different types of filter media can be used with the EOF Fryer, either disposable Filter Paper or a renewable stainless steel mirco-mesh filter screen (SSFS)

CAUTION

- **Never attempt to filter cold shortening; the thickened shortening can clog the filter pump and potentially damage the unit. Shortening must be heated to a minimum of 200°F (93°C) before filtering.**
- **Parts of the Fryer may be extremely HOT! Always wear thermal mitts or gloves when performing this procedure.**

1. After the fourth (4th) load has been cooked in a vat, the oil needs to be filtered.
2. Place the Heat Switch **1** for the unit to be filtered in the **OFF** position .
3. Open the FFLT Cabinet Door. While wearing hand protection, disconnect the Filter Pan quick-disconnect hose **2** and remove the empty Filter Pan **3** from under the unit.
4. **Using Filter Paper:** Ensure that (1) sheet of Filter Paper is installed correctly in Filter Pan and that the Hold-down Frame is securely locked in place. **Two (2) pieces of paper are required for older models without the permanent Filter Pan screen.**
Using Renewable Mesh Screen: Ensure the Screen is free of residue and properly seated in the Filter Pan bottom. Be certain that no debris is trapped underneath the gasket and that the Hold-down Frame is securely locked in place.
5. Evenly distribute approximately 4-3/4 oz. of an appropriate Filter Powder evenly over the filter media surface ... Giles #72004 is recommended.
6. Ensure the Filter Pan Cover **4** is in place, then reposition Filter Pan under the unit. Reconnect the Filter Pan quick-disconnect hose **2** to the proper fitting on the Fryer.

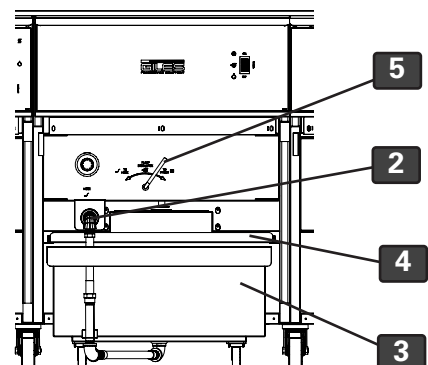
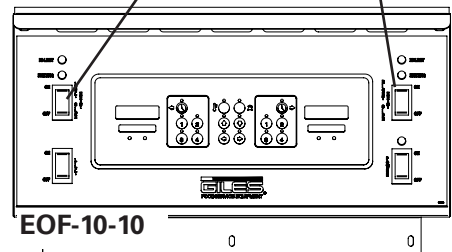
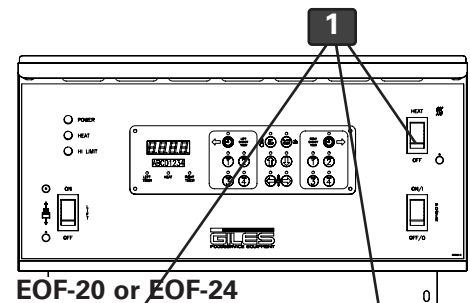

5-03. Filtering Liquid Shortening (Continued from previous page)

⚠ DANGER

- During the next step hot shortening is drained into the Filter Pan, which will expose the Heating Elements. Failure to have the fryer's Heat Switch in the OFF position prior to draining may result in fire. **ALWAYS CONFIRM THE HEAT SWITCH IS IN THE "OFF" POSITION BEFORE DRAINING THE THE COOK VAT.**

⚠ WARNING

- Never drain oil from more than one (1) cook vat at a time into the Filter Pan! The Filter Pan only has capacity to contain the oil from one (1) vat.
- Never disconnect and attempt to remove the Filter Pan from unit while it contains liquid shortening.

7. Confirm that the Heat Switch **1** for the unit to be filtered is in the **OFF** position. On the FFLT lower panel, ensure the Oil Diverter Valve is in the **TO FRYPOT** **5** position. Unlock and slowly pull the Drain Valve Handle **6** out to the **OPEN** position, allowing the cooking oil to drain into the Filter Pan.

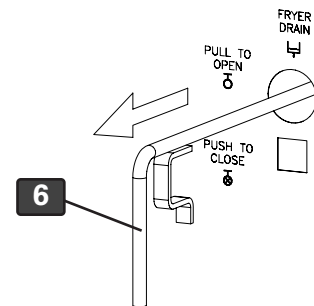

NOTE:

- If the Fry Vat does not readily drain, use the supplied Drain Brush or Clean-out Tool to break up crumbs or cooking residue which may be blocking the Fry Vat Drain.

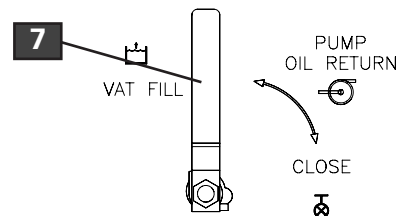

8. Move the Pump - Oil Return Valve Handle **7** for the unit to be filtered to the **VAT FILL** position.
9. After the Fry Vat has completely drained, place the Pump Switch **8** in the **ON** position.

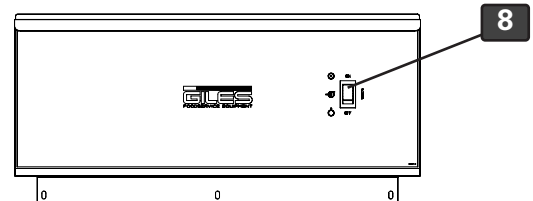

5-03. Filtering Liquid Shortening (Continued from previous page)

10. The used oil will be pumped from the Filter Pan, through the filter media and recirculated back to the Fry Vat **9**. Leave the Drain Valve open and allow the oil to continually circulate through the system for at least 5 minutes. During this time it is advisable to remove the Crumb Screen and use the Pot Brush and Element Brush to scrub the vat walls and elements, allowing residue to be flushed into the Filter Pan.

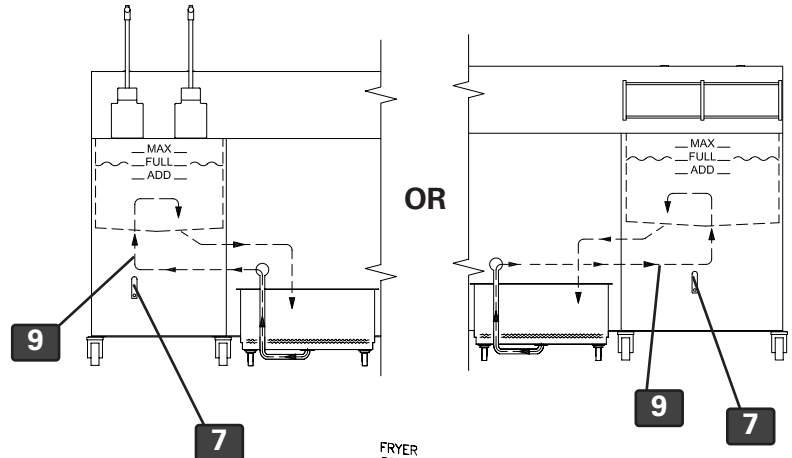

11. After 5 minutes, replaced the Crumb Screen if removed, push in and lock the Drain Valve Handle **10** in the **CLOSED** position and allow the Fry Vat to refill. When all oil has been pumped back to the vat, air bubbles will appear at the pump discharge inside the vat.

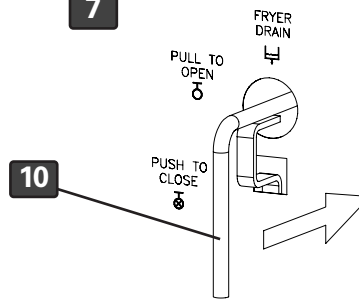

12. After the Fry Vat has refilled, place the Pump Switch **11** in the **OFF** position.

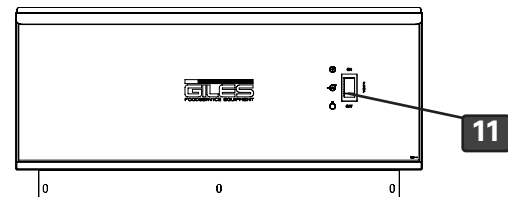

13. Position the Pump Oil Return Lever **12** on the unit being filtered to the **CLOSE** position.

14. Ensure the Fry Pot contains the proper level of liquid shortening ... add if needed.

15. • To continue cooking, See **Section 5-2, Cooking Procedure**.

• To discontinue cooking, See **Section 5-5, Normal Shut-Down**.

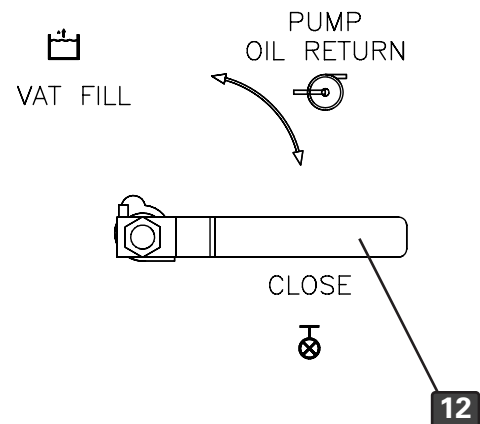

5-04. Removing Used Shortening

This section describes the procedure for removing used shortening from the unit for disposal or prior to performing a fryer Boil Out. A Giles Oil Caddy (**not supplied**) is depicted as being used for disposal of used shortening.

CAUTION

- **Never attempt to pump cold shortening; the thickened shortening can clog the filter pump and potentially damage the unit. Shortening must be heated to a minimum of 200°F (93°C) before filtering performing this procedure.**

1. If shortening is cold, heat to 200°F (93°C).
2. Ensure the Power Switch **1** is in the **ON** position.
3. Next, confirm that the Heat Switch **2** is in the **OFF** position.
4. Ensure the Filter Pan **3** and the Filter Pan Cover **4** are in place. Confirm the quick disconnect hose **5** is properly connected to the unit. Verify the Pump Discharge Valve Handle **6** is in the **TO FRYER** position.

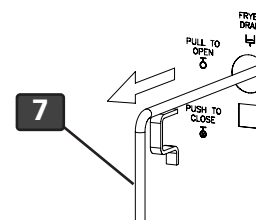
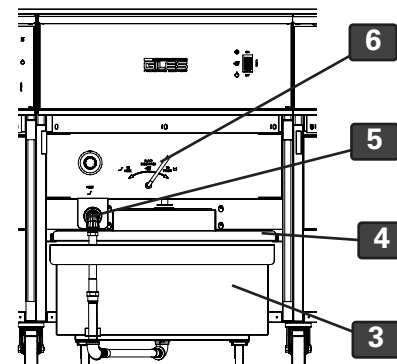
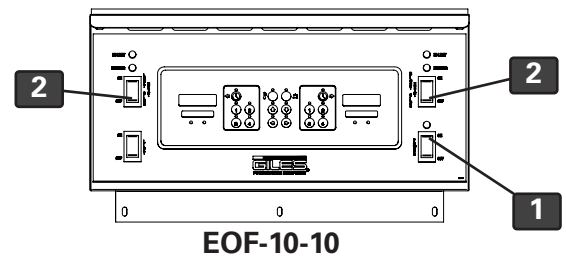
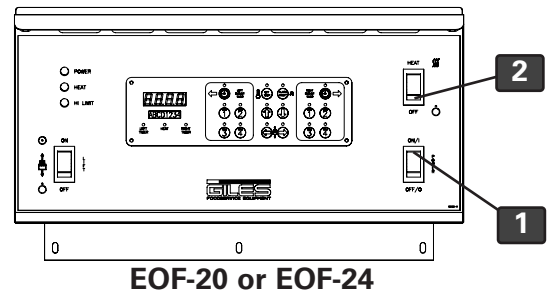

DANGER

- **During the next step hot shortening is drained into the Filter Pan, which will expose the Heating Elements. Failure to have the fryer's Heat Switch in the OFF position prior to draining may result in fire. ALWAYS CONFIRM THE HEAT SWITCH IS IN THE "OFF" POSITION BEFORE DRAINING THE COOK VAT.**

WARNING

- **Never drain oil from more than one (1) cook vat at a time into the Filter Pan! The Filter Pan only has capacity to contain the oil from one (1) vat.**
- **Never disconnect and attempt to remove the Filter Pan from unit while it contains liquid shortening.**

5. Slowly unlock and pull the Drain Valve Handle to the **OPEN** **7** position and allow the oil to completely drain into the Filter Pan.

Continued next page

5-04. Removing Used Shortening (Continued from previous page)

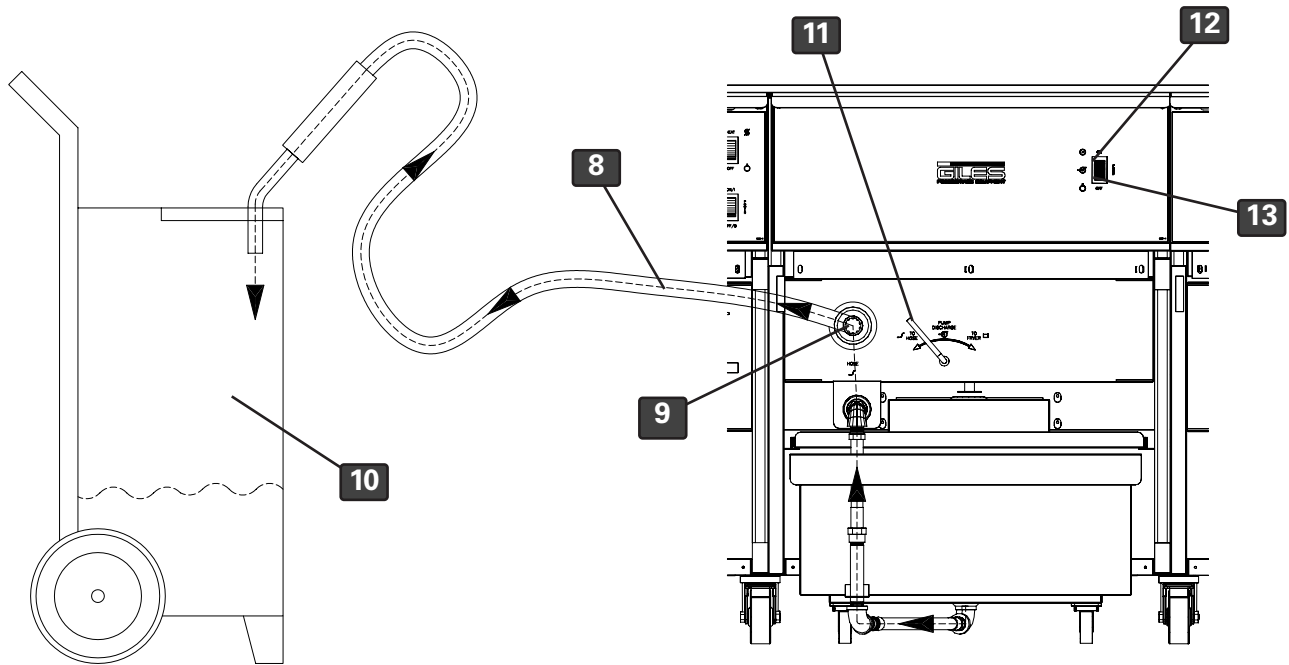

6. Connect the supplied Oil Discharge Hose **8** to the Discharge Hose Coupling **9**.
7. Place the discharge end into an appropriate Hot Oil Disposal Container **10** (Giles Oil Caddy is shown)
8. Turn the Pump Discharge Valve Handle **11** to the **TO DISCHARGE HOSE** position.

WARNING

- When handling the Discharge Hose during the next step, be sure to wear thermal mitts or gloves, as the hose can become very hot.

9. Place the Pump Switch **12** in the **PUMP** position. Allow the pump to run until all liquid shortening has been pumped into the Disposal Container.
10. After all the used oil has been removed from the Filter Pan, place the Pump Switch **13** to the **OFF** position.

5-04. Removing Used Shortening (Continued from previous page)

11. Place the Power Switch in the **OFF** **14** position.
12. Push and lock the Drain Valve to the **CLOSED** **15** position (tab tucked behind panel).
13. Turn the Pump Discharge Valve Handle to the **TO FRYPOT** **16** position.

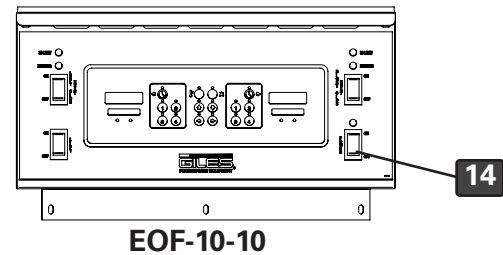
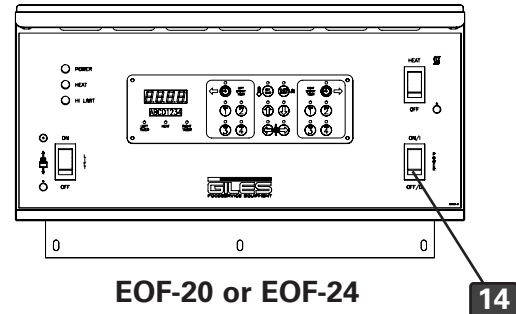

⚠ WARNING

- During the next step be sure the wear thermal mitts or gloves as the Discharge Hose and the Discharge Hose Coupling will have become very hot.

14. Remove the Discharge Hose from the Discharge Hose Coupling and drain any oil remaining in the hose into the Oil Disposal Container.
15. Allow the Filter Pan to thoroughly cool. Remove and thoroughly clean the Filter Pan and Filter Pan Cover.
16. • To perform a Boil Out on the unit see **Section 6-1, Boil Out Procedure.**
 • To shut down the unit see **Section 5-5, Normal Shut-Down.**

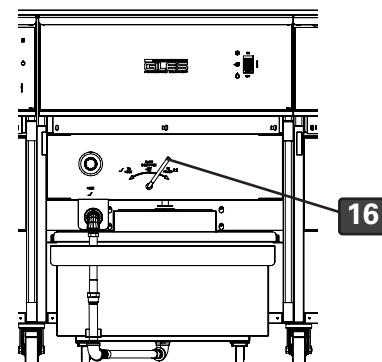
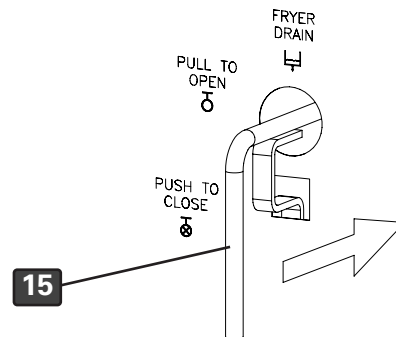

5-05. Using the Optional Renewable Filter Media (SSFS)

This section describes use and care of the renewable, stainless steel, Filter Screen (SSFS). The SSFS is a direct replacement for paper filter media that can be cleaned and reused many times. It is an optional item (**Giles #41017**) that can be ordered with new units or purchased later as a filter paper alternative.

1. Place the SSFS into the Filter Pan same as filter paper. **DO NOT use filter paper and the Screen at the same time.**
2. Ensure that the edge gasket is flat against Pan bottom. Position the Hold-down Frame and lock into place with the locking levers. Levers may not fully close when using the Screen ... this will not affect performance.
3. For best filtering results, always use an appropriate filter aid, such as **Giles #72004 Filter Powder**. Distribute the prescribed amount evenly over the surface, same as with filter paper.
4. After performing a regular filtering cycle, see **Section 5-03, Filtering Shortening**, clean accumulated filter sediment from the SSFS surface with the supplied Crumb Shovel, or other suitable utensil, and discard. It might be necessary to remove the SSFS to brush remaining residue from its surface.
5. If Screen is removed, do not allow filter residue to fall into the Filter Pan bottom and be certain to reinstall the screen with the soiled side up; wipe any residue from the edge gasket before installing.



5-05.1. Washing the Renewable Filter Media (SSFS)

1. It is not necessary to wash the SSFS Filter Screen after every filtering cycle.
2. On a weekly basis, remove the SSFS Screen and clean it in a sink, using **ONLY** hot water and a soft bristle brush. **DO NOT USE SOAP or OTHER CLEANERS** when washing the Screen. Doing so may affect oil life and quality. It is highly unlikely that soap residue can be completely rinsed from the screen and it will eventually be transferred to the cooking oil during subsequent filter cycles.
4. **DO NOT USE OVEN CLEANERS or CAUSTIC PRODUCTS** to clean the Screen. These chemicals will damage the silicone edge gasket and residue can be transferred to the cooking oil.
5. Before reinstalling the clean SSFS in the Filter Pan, shake off excess water and dry with a clean towel. Be certain screen is dry before using. If possible, it is best to allow screen to dry overnight.
6. Take care not to cut or tear the silicone edge gasket. Inspect the Screen weekly for damage, such as fraying, holes, damaged gasket, etc. A damaged screen should be removed from service and replaced immediately.



5-06. Normal Shut-Down

This section explains the process of Fryer shutdown.

1. Place the Heat Switch in the **OFF 1** position.
2. Place the Power Switch to the **OFF 2** position, the Power Light **3** will turn off.
3. If required, turn off fryer supply power at the main circuit breaker panel.

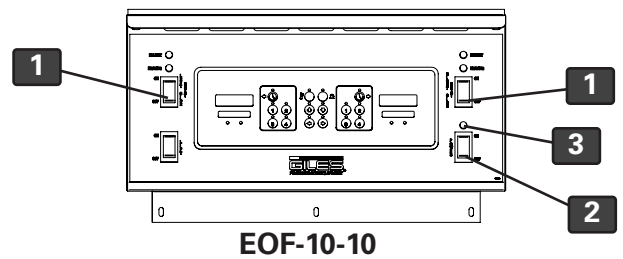
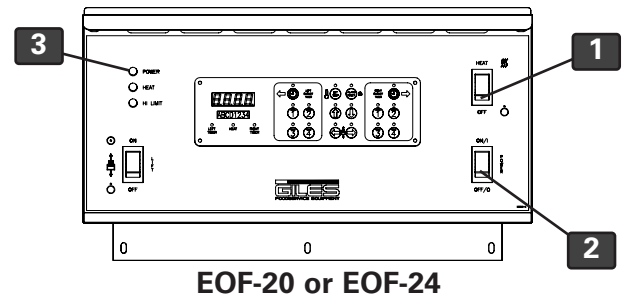

5-07. Emergency Shut-Down

In case of emergency, remove power to the unit by turning off the facility circuit breaker.

6. Cleaning

This section describes cleaning operations for the EOF Model Banked Fryers. General cleaning should be performed on a daily basis, other specific procedures should be performed as stated.

⚠ DANGER

- **DO NOT** wash down the unit's interior or exterior with water from a spray hose or pressure-type washer.
- Failure to comply with these DANGER notices will result in death or serious injury, equipment or property damage, and void the warranty.

6-01. Boil-Out Procedure (Cleaning the Fry Pot)

This section describes how to clean the Fry Vat; the process is referred to as Boil-Out. The Boil-Out process must be performed before cooking with new equipment, and should be performed each time prior to refilling the vat with fresh shortening.

For proper fryer maintenance and operation, the Boil-Out procedure should be performed every 7 to 14 days.

⚠ DANGER

- **DO NOT**, under any circumstances, leave the fryer unattended during this procedure as it may become necessary to adjust heat settings to avoid vat overflow. Overflow may result in serious equipment damage.

1. Remove shortening from the unit, see **Section 5-4, Removing Used Shortening**.
2. Ensure the Drain Valve Handle is pushed in and locked in the **CLOSED 1** position and the Power Switch 6 is in the **OFF** position.
3. Fill the Fry Vat with clean water to the **FULL** level mark **2**.
4. Follow the directions on the Boil-Out Cleaner product being used ... add the recommend amount of product to the vat.

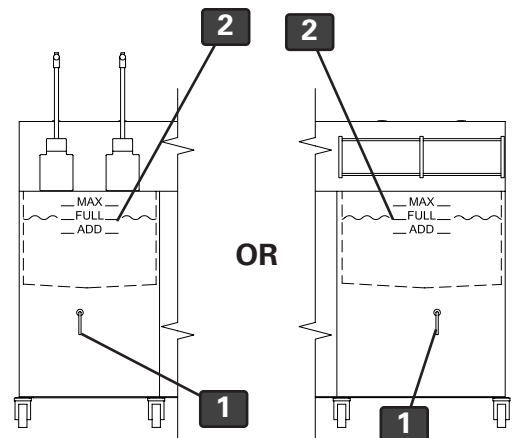

⚠ CAUTION

- **Closely adhere to the fryer cleaner manufacturer's usage instructions. Many commercially available fryer cleaning products contain caustic chemicals and require special precautions when used. Improper use, may damage the fryer and also present potential for personal injury.**

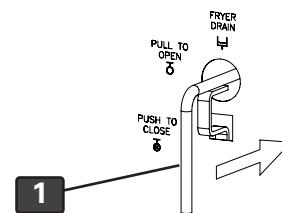

Continued next page

6-01. Boil Out Procedure (Continued)

5. Place the Power Switch **3** in the **ON** position.
6. Set the Cooking Temperature to the temperature recommended for the boil-out product being used. **See Section 5-1.2.**
7. Place the Heat Switch **4** in the **HEAT** or **ON** position.
8. The boil-out solution will heat to recommended setpoint. See product instructions for suggested cleaning cycle time.
 If desired, one of the Timer buttons can be set for the suggested boil-out time. **See Section 5-1.3.**
9. At the completion of the Boil-Out cycle time, place the Heat Switch **5** and Power Switch **6** in the **OFF** position.
10. Disconnect Filter Pan quick-disconnect hose. Remove the Filter Pan and Filter Pan Cover.

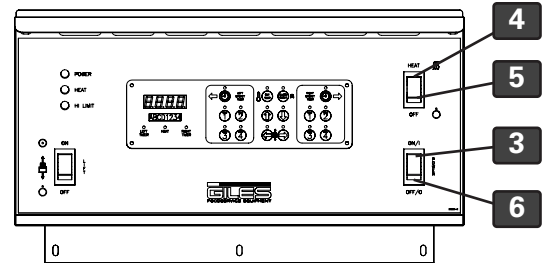

EOF-20 or EOF-24

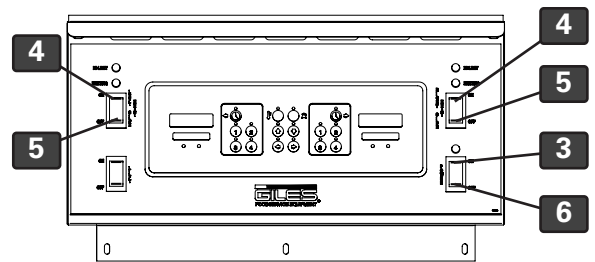

EOF-10-10

CAUTION

- **NEVER** drain the Boil-Out solution into the Filter Pan! It is corrosive and will cause damage to the Filter Pan, Mesh Filter Screen (if equipped), Hold-Down Frame and Filter Pump. Failure to comply could cause minor to moderate personal injury, equipment or property damage, and result in voiding the warranty.
- Use a catch container that is heat rated for 300°F (148°C). General-use plastic containers are typically not desirable; they may melt or break. A leak-proof metal container is preferable, but any container made of suitable high-temperature rated material may be used. Failure to comply with this caution may result in serious injury.
- Always wear rubber gloves and use thermal mitts when handling and discarding the hot boil-out solution.

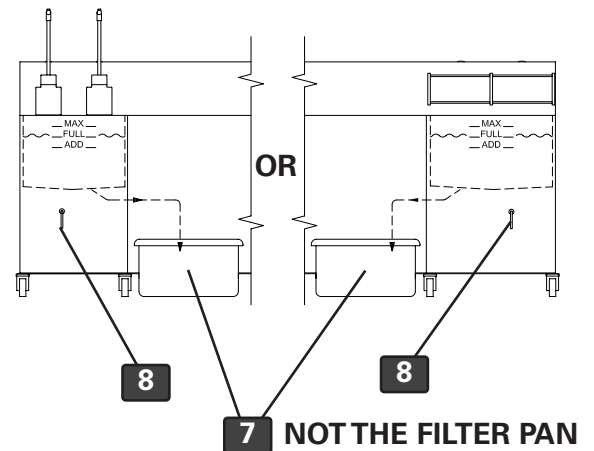

11. Position a suitable Heat Resistant Container **7** (not supplied) beneath the Fryer Drain.
12. Unlock and slowly pull the Drain Valve Handle to the **OPEN** **8** position.

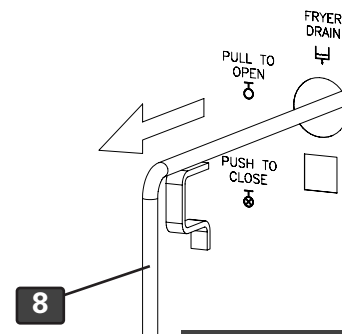

Continued next page

6-01. Boil Out Procedure (Continued)

13. Remove Screen from the vat and, as needed, use the Pot Brush & Element Brush to scrub vat sides, bottom, heating elements, etc. to remove oil residue. Rinse and flush the Fry Vat thoroughly with clean warm water.

Note: Take care to avoid damaging the temperature probes located inside the vat and attached to heating elements.

14. Completely dry the vat with a clean dry towel and properly dispose of the used boil-out solution.
15. Push in and lock Drain Valve Handle in the **CLOSE** **9** position.
16. Clean Filter Pan and replace Filter Media. See directions in **Section 6-02, Cleaning the Filter Pan & Replacing Filter Media After Boil Out.**
17. Re-install Filter Pan Cover **10**.
18. Position Filter Pan **11** under unit and connect Filter Pan quick-disconnect hose to unit **12**.
19. Restart the fryer for cooking. **See Section 5-2.**

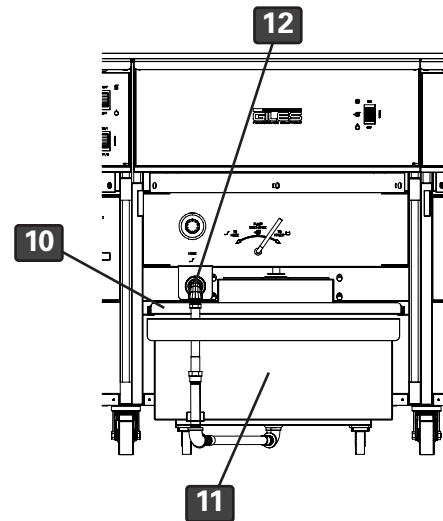
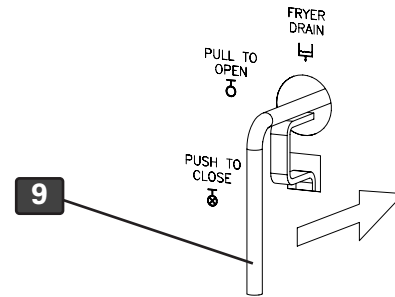

6-02. Cleaning the Filter Pan & Renewing Filter Media After Boil Out

This section explains the procedure for cleaning the Filter Pan and renewing the Filter Media. This should be done each time the Boil-Out procedure (**Section 6-01**) is performed.

CAUTION

- Use thermal mitts or gloves to protect hands from hot parts.

1. Filter Pan should have been removed prior to draining boil-out solution.
2. Remove & clean Crumb Screen **1**, using a biodegradable, non-toxic cleaner.
3. Use the supplied metal Crumb Scoop to remove as much of the accumulated filter sediment as possible from the filter media surface, particularly around the edges. This will help prevent debris from getting underneath the renewed filter media or falling through the perforated support screen and potentially causing the filter pump to clog.
4. Clean the Filter Pan Cover **2**, using a biodegradable, non-toxic cleaner. Dry it thoroughly.
5. Turn the four Lever **4** to disengage the Hold-down Frame **5**. Remove, clean and dry Frame thoroughly.
6. Remove the Filter Media **6**, either Filter Paper or Mesh Screen (SSFS).

Using Paper: Carefully roll up soiled filter sheet and discard; avoid allowing filter debris to fall through the permanent, perforated support screen **7** in the Filter Pan bottom.

Using SSFS Screen: Remove the screen; avoid allowing filter debris to fall through the permanent, perforated support screen **7** in the Filter Pan bottom. Using only hot water and a soft bristle brush, clean screen in sink. Shake out water and dry with clean dry towel. **DO NOT use soaps or cleaners of any kind when washing the SSFS Screen!**

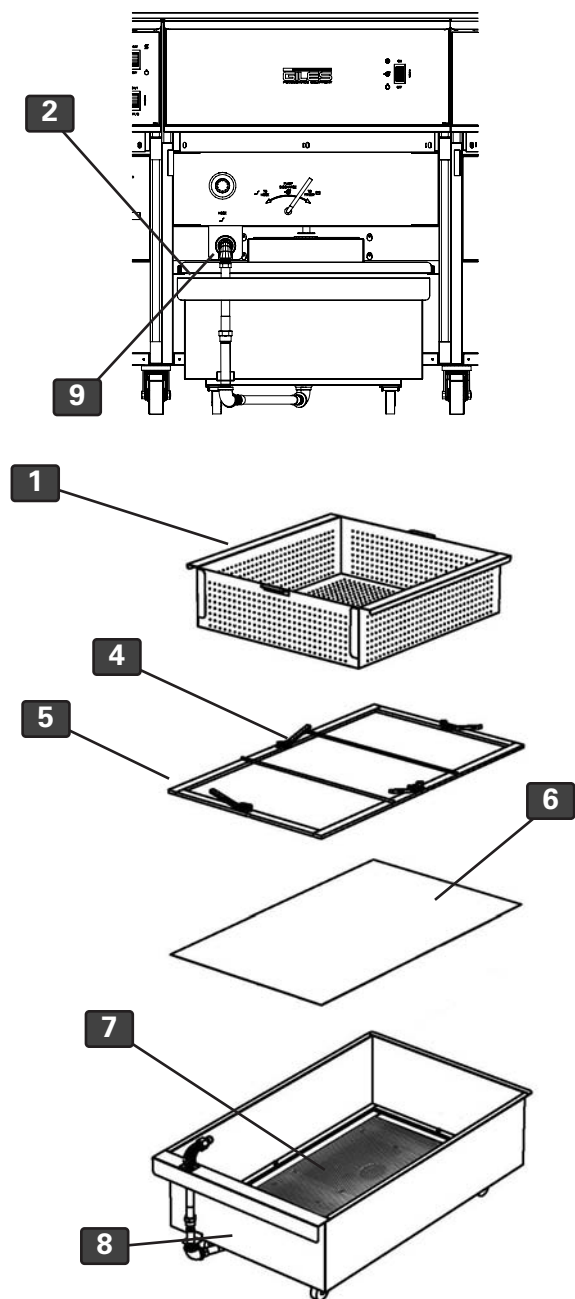

6-02. Cleaning the Filter Pan & Renewing Filter Media After Boil Out (Continued)

7. Thoroughly clean and dry the Filter Pan **8**. Flush out any debris that may have fallen through the perforated support screen in the Pan bottom.
8. Reassemble the Filter Pan with either (1) new sheet of Filter Paper or the clean SSFS Screen, as applicable.
9. Reinstall Filter Pan Cover, position assembled Filter Pan under Fryer and re-connect the quick-disconnect hose **9**.

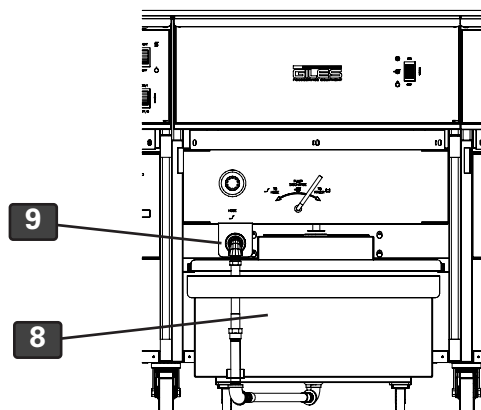

6-03. Daily Cleaning the Filter Pan & Renewing the Filter Media

This section explains the process for the daily cleaning of the Filter Pan and renewing the Filter Media. This procedure should be performed as required by actual cooking load, but at a minimum once daily.

CAUTION

- Use thermal mitts or gloves to protect hands from hot parts.

1. Follow the Normal Shut-Down procedure, **see Section 5-05**.
2. Disconnect quick-disconnect hose; remove the Filter Pan **1** and Filter Pan Cover **2**.
3. Clean Filter Pan Cover thoroughly, using a biodegradable, non-toxic cleaner.
4. Remove and clean Crumb Screen **3**, using a biodegradable, non-toxic cleaner.
5. Use the supplied metal Crumb Scoop to remove as much accumulated filter sediment as possible from the filter media surface, particularly around the edges. This will help prevent debris from getting underneath the renewed filter media or falling through the perforated support screen, which could potentially cause the filter pump to clog.

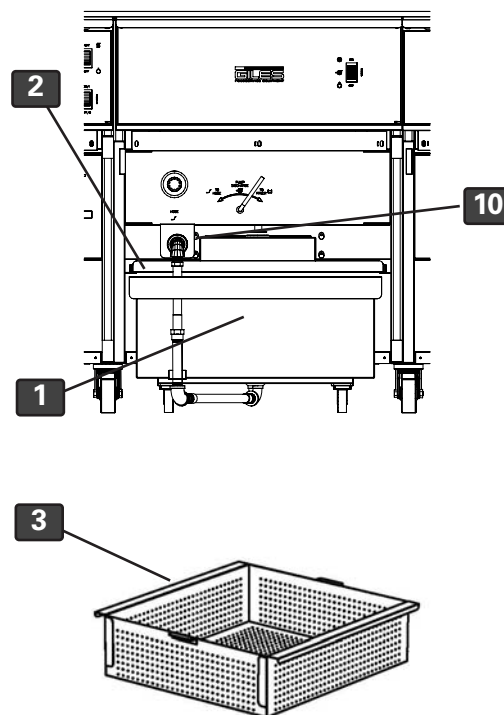

6-03. Daily Cleaning the Filter Pan & Renewing the Filter Media (Continued)

6. Turn the four Levers **4** to disengage the Hold-down Frame **5** ... remove, clean and dry it thoroughly.

7. Remove the Filter Media **6**, either Filter Paper or Mesh Screen (SSFS).

Using Paper: Carefully roll up soiled filter sheet and discard; avoid allowing filter debris to fall through the permanent, perforated support screen **7** in the Filter Pan bottom.

Using SSFS Screen: Remove the screen; avoid allowing filter debris to fall through the permanent, perforated support screen **7** in the Filter Pan bottom. Simply shake or brush remaining filter residue from the screen. The SSFS Screen only requires washing weekly (it should also be washed when performing the Boil-Out procedure), **see Section 5-06.1**. Take care not to cut or tear the silicone border gasket.

8. Thoroughly clean, rinse and dry the Filter Pan **8**. Flush out any debris that may have fallen through the perforated support screen. Stand Pan on end to drain any water from the Pan's tubing.

10. As applicable, reassemble the Filter Pan with either (1) new sheet of Filter Paper or the cleaned SSFS Screen **6**.

11. Reinstall Filter Pan Cover, position assembled Filter Pan under the unit and re-connect the Quick-disconnect Hose **9**.

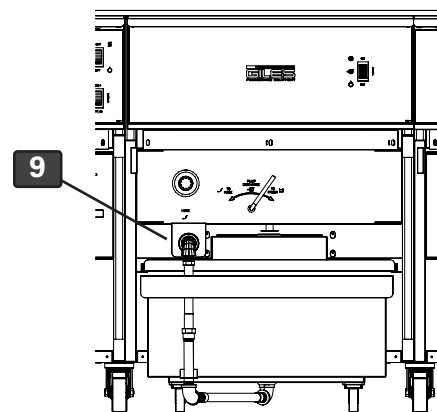
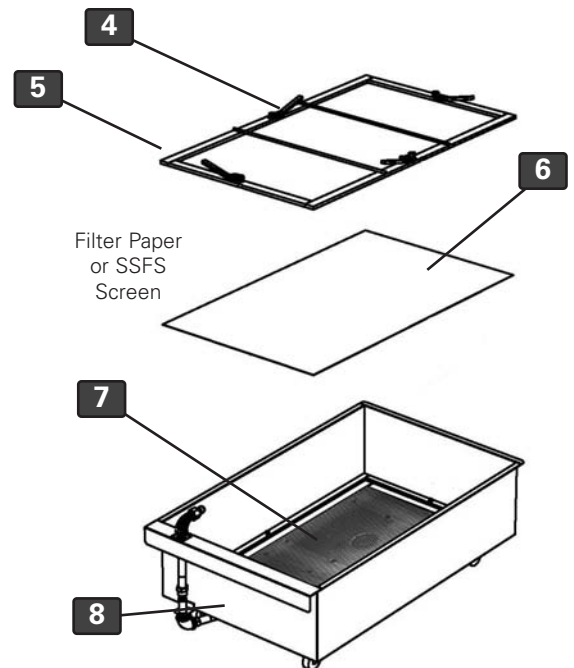

7. Troubleshooting

This section describes troubleshooting procedures. Refer to the wiring diagrams in Section 9 as an aid to more detailed analysis, if needed.

| 7-01. Temperature Control System | | |
|--|--|---|
| Problem | Probable Cause | Repair Procedure |
| FRYER WILL NOT TURN ON: No power light | A. Not connected to power source | A. Connect to power source |
| | B. Faulty fuse or circuit breaker | B. Check fuse or breaker |
| | C. Fuse holder cracked | C. Replace fuse holder |
| | D. Faulty Power Switch | D. Replace Power Switch |
| | E. Improper supply voltage | E. Connect to proper voltage source |
| FRYER WILL NOT HEAT: Power light ON. Heat light OFF. | A. Heat Switch not in "Heat (On)" position. | A. Place Heat Switch in "Heat" position. |
| FRYER WILL NOT HEAT: Power light ON. Heat Switch in "Heat" position. Heat light OFF. | A. Controller programmed below actual oil temperature. | A. Set temperature controller to desired temperature. |
| | B. Drain Valve open. | B. Close Drain Valve. Press Alarm Reset Button on Controller. |
| | C. Faulty cooking Controller. | C. Replace cooking Controller. |
| | D. Variable probe shorted or open. | D. Replace probe |
| | E. Loose wire. | E. Repair loose wire. |
| | F. Contactor failure. | F. Replace faulty contactor. |
| | G. Element bad. | G. Replace element. |
| | H. Heat Switch bad. | H. Replace Heat Switch. |
| | I. Low Oil Level | I. Turn Power Switch Off and Add Oil. |

| 7-01. Temperature Control System (Continued) | | |
|--|-------------------------------------|--|
| Problem | Probable Cause | Repair Procedure |
| FRYER HEATING SLOW: (slow recovery) Heat light stays ON. | A. Incorrect Cooking procedures. | A. Consult Operations Manual for proper Cooking procedure. |
| | B. Element failing. | B. Replace bad Element. |
| | C. Contactor failing. | C. Replace Contactor. |
| | D. Loose Wire. | D. Repair Loose Wire. |
| | E. Low Supply Voltage. | E. Supply proper Voltage. |
| FRYER HEATS SLOW: (short cycling) Heat light OFF and ON CONTINUOUSLY. | A. Low supply Voltage. | A. Supply proper Voltage. |
| | B. Variable probe touching element. | B. Reposition variable probe. |
| | C. Faulty cooking Controller. | C. Replace cooking Controller. |
| OIL TEMPERATURE ERRATIC: | A. Probe bad. | A. Replace Probe. |
| | B. Contactor failing. | B. Replace Contactor. |
| | C. Faulty cooking Controller. | C. Replace cooking Controller. |
| | D. Loose Wire. | D. Repair loose Wire. |
| OIL SMOKING: | A. Oil being used too long. | A. Change oil. |
| | B. Over temperature. | B. Check temperature setting. |
| | C. Dirty element. | C. Clean elements, using Fry Vat cleaning brush. |
| | D. Faulty element. | D. Replace element. |
| | E. Improper element voltage. | E. Supply proper Voltage. |
| | F. Low Oil level. | F. Keep Oil at FULL Level. |



7-01. Temperature Control System (Continued)

| Problem | Probable Cause | Repair Procedure |
|---|------------------------------------|---|
| FRYER WILL NOT HEAT: Power light ON. Heat Switch in Heat position. High Limit light ON. | A. Power surge. | A. Turn Power Switch OFF for 5 seconds. |
| | B. Sticking Contactor. | B. Replace Contactor. |
| | C. Bad High Limit Board. | C. Replace High Limit Board. |
| | D. High Limit Probe short or open. | D. Replace High Limit Probe. |
| | E. Line spikes or noise. | E. Filter Line or remove noise source. |

7-02. Oil Filtration System

| Problem | Probable Cause | Repair Procedure |
|--------------------------------------|--|---|
| OIL NOT RETURNING TO FRY POT: | A. Pump Switch not in "Pump" position. | A. Place Selector Switch in "Filter/Pump" position. |
| | B. Air Leak (hose, fittings, filter paper). | B. Repair Air Leak. |
| | C. Pump Motor Bad. | C. Replace Pump Motor. |
| | D. Oil Pump Sticking. | D. Free Stuck Pump. |
| | E. Diverter Valve not in "TO FRYER" position. | E. Place Diverter Valve in "TO FRYER" position. |
| | F. Using pump to handle used boil-out. | F. Disassemble and re-oil pump. |
| | G. Old oil allowed to sit in pump. | G. Run clean oil through pump. |
| | H. Oil cold or below 200°F (93°C) in Filter Pan. | H. Remove Filter Pan and remove cold oil from Filter Pan. |
| | I. Filter Pan incorrectly assembled. | I. Assemble Filter Pan correctly. |
| | J. Dirty Filter Pan. | J. Clean Filter Pan. |



7-03. Basket Elevator System (Basket Elevator Option Only)

| Problem | Probable Cause | Repair Procedure |
|--------------------------------------|---|--|
| BASKET WILL NOT GO UP OR DOWN | A. Power not ON. | A. Press Power Switch to ON position. |
| | B. Faulty cooking Controller. | B. Replace cooking Controller. |
| | C. Elevator micro-switch out of adjustment. | C. Adjust Elevator micro-switch. |
| | D. Faulty elevator micro-switch. | D. Replace elevator micro-switch. |
| | E. Elevator switch not in ON position. | E. Press elevator switch to ON position. |
| | F. Faulty elevator motor. | F. Replace motor. |

8. Parts List

This section lists various parts that are available for replacement on the unit.

8-01. Parts Ordering and Service Information

If you require assistance or need repairs, please contact your Giles Representative to locate a service agency in your area. For further assistance, please contact Giles Enterprises, Inc. at one of the following phone numbers:

IN THE UNITED STATES, CANADA or MEXICO

Call **800.554.4537** during normal business hours, 8:00AM to 5:00PM Central Time. For emergency equipment repair service after normal business hours, call 800.554.4537 and follow the recorded prompts to obtain after-hours support..

IN ALL OTHER COUNTRIES

Call **334.272.1457** during normal business hours, 8:00AM to 5:00PM Central Time Zone and follow the recorded prompts. For emergency equipment repair service after normal business hours call, 334-272-1457 and follow the recorded prompts to obtain after-hours support..

WEBSITE:

Please visit our website: www.gfse.com. E-mail: services@gfse.com

The goal of the Giles team is to provide you with the best possible service and assistance. You can help us accomplish this by obtaining the following information and having it readily available when calling. The information is recorded on the Data/Serial Label attached to the Back Panel of each Fryer unit.

| | | | | |
|--|----|------------------------|------|-------|
| MODEL/MODELE | | SERIAL NO/NO. DE SERIE | | |
| VAC/VCA | HZ | PHASE | AMPS | WATTS |
| | | | | |
| DESCRIPTION/DESCRIPCIÓN | | | | |
| | | | | |
| GILES ENTERPRISES 1-800-554-4537 2750 GUNTER PARK DRIVE WEST • MONTGOMERY • ALABAMA • 36109 | | | | |

The area below may be helpful in recording information for use as a quick reference.

Model Number: _____

Serial Number: _____

Phase: _____

Voltage: _____

Be ready prepared to describe the nature of the problem.

8-02. EOF-10-10 Control Panel & Front Header

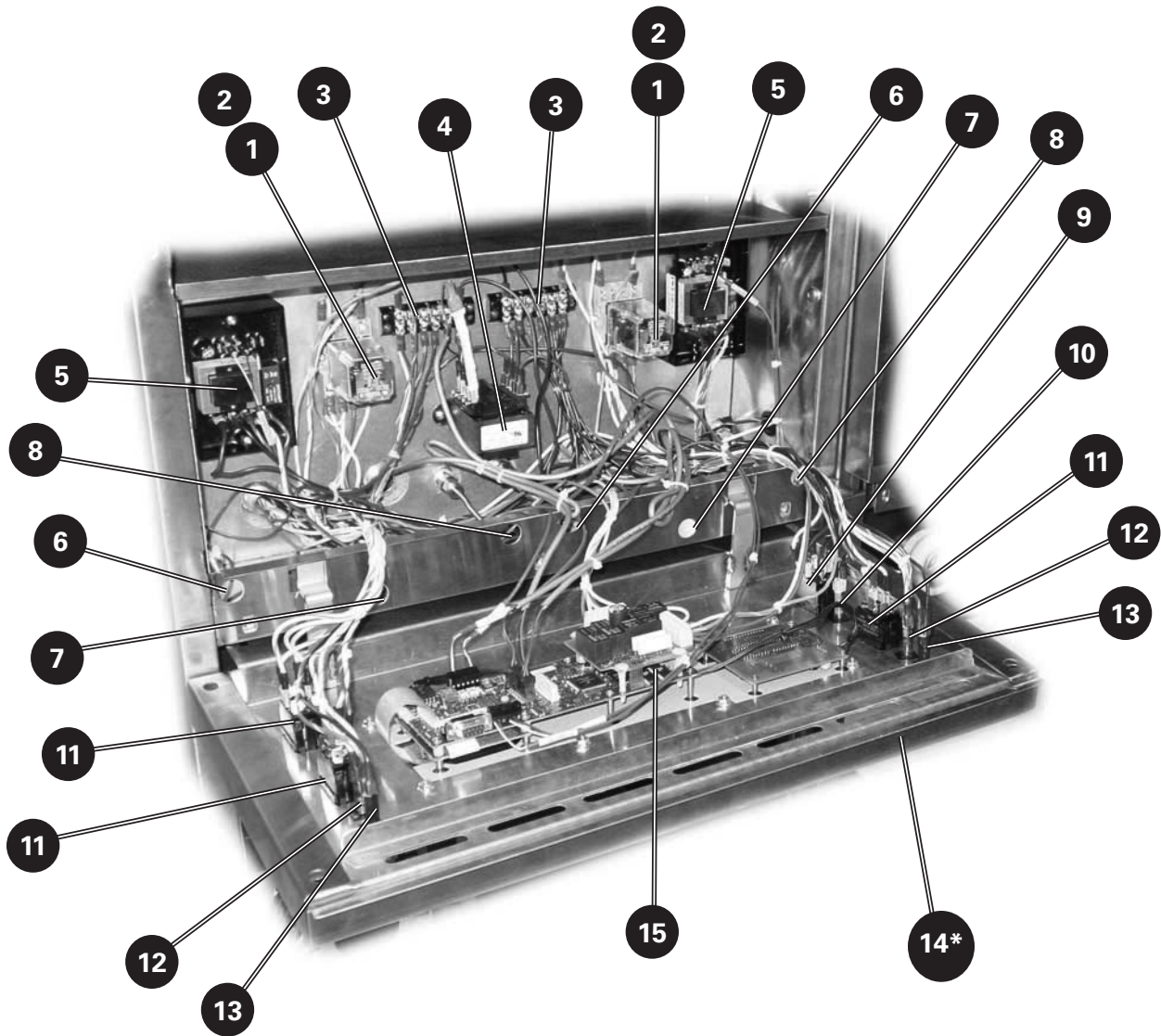

* Not shown

Parts List

EOF-10-10/FFLT/24, EOF-10-10/FFLT/24/24
 EOF-20/FFLT/24, EOF-20/FFLT/24/24

8-02. EOF-10-10 Control Panel & Front Header

| Item | Part No. | Qty. | Description |
|------|----------|------|--|
| 01 | 21101 | 2 | SOCKET, RELAY, 8 PIN, 300V, 10A, CR-5 |
| 02 | 21102 | 2 | RELAY, 8 PIN, 240V COIL, 10A |
| 03 | 23751 | 2 | TERMINAL BLOCK, MA106,6 POLE |
| 04 | 20366 | 1 | TRANSFORMER,18VA,CL2,115/230V,60HZ |
| 05 | 23755 | 2 | THERMOSTAT, SAFETY, WATLOW, 450DEG |
| 06 | 20315 | 2 | THERMOCOUPLE,13.5",STRAIGHT,J TYPE (REQUIRES P/N 45111 FERRULE) |
| 07 | 20362 | 2 | THERMOCOUPLE,7.5 X 0.188,J-TYPE,STRAIGHT (REQUIRES P/N 45111 FERRULE) |
| 08 | 20365 | 2 | THERMOCOUPLE, 12 INCH , J-TYPE, EOF-10 (REQUIRES P/N 45111 FERRULE) |
| 09 | 21190 | 1 | SWITCH, ROCKER, ON-OFF, 250V, 20A, DPST |
| 10 | 38215 | 1 | LIGHT, INDICATOR, GREEN,250VAC |
| 11 | 21052 | 3 | SWITCH,ROCKER,ON-NONE-ON,250V,20A,DPDT |
| 12 | 38213 | 2 | LIGHT, INDICATOR, ORANGE,250V |
| 13 | 38214 | 2 | LIGHT, INDICATOR, RED,250VAC |
| 14* | 63778 | 1 | LABEL, CONTROL PANEL, EOF-10-10 |
| 15 | 20364 | 1 | CONTROLLER, N7, DUAL DISPLAY, WATLOW |

* Not shown

8-03. EOF-10-10 Front Lower Cabinet

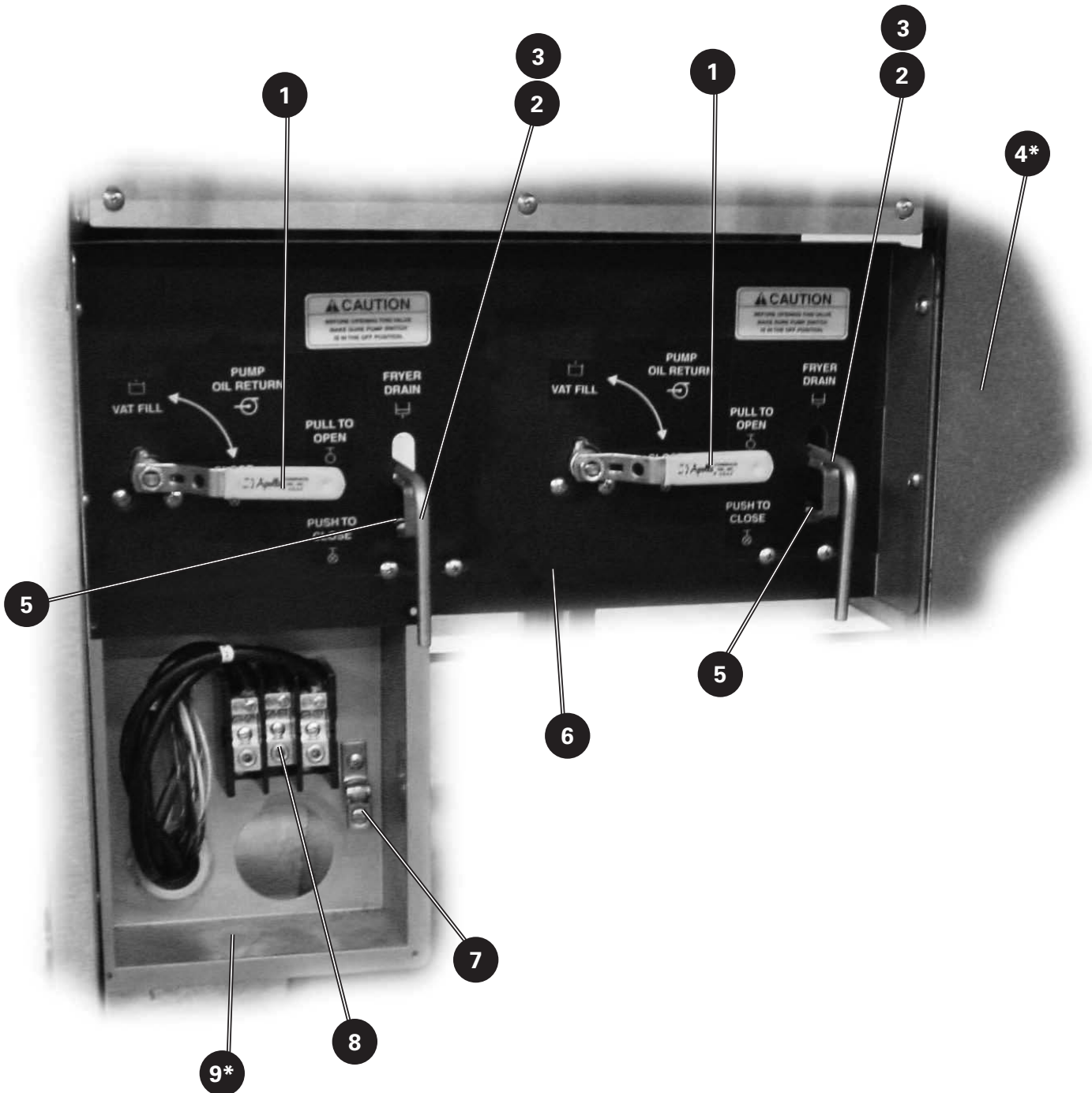

* Not shown

Parts List

EOF-10-10/FFLT/24, EOF-10-10/FFLT/24/24
EOF-20/FFLT/24, EOF-20/FFLT/24/24

8-03. EOF-10-10 Front Lower Cabinet

| Item | Part No. | Qty. | Description |
|------|----------|------|--|
| 01 | 40784 | 2 | VALVE,BALL,1/2",S/S w/NON-STICK SEALS |
| 02 | 39258 | 2 | HANDLE, DRAIN PULL |
| 03 | 40818 | 2 | VALVE,BALL,1-1/4",DRAIN,SINGLE THREAD END |
| 04* | 35151 | 1 | DOOR ASSEMBLY |
| 05 | 21157 | 2 | SWITCH, LIMIT, 15A, 250V DRAIN SWITCH |
| 06 | 63986 | 1 | LABEL, FRONT BRACE, EOF-10-10 |
| 07 | 21051 | 1 | LUG, 1/0-2/0 COPPER TERMINAL 125A 1/4" BOLT HOLE |
| 08 | 21164 | 1 | POWER DIST,TERMINAL BLOCK |
| 09* | 39978 | 1 | COVER, SERVICE CONNECTION, EOF-10-10 |

* Not shown

8-04. EOF-10-10 Rear Upper & Lower Cabinet

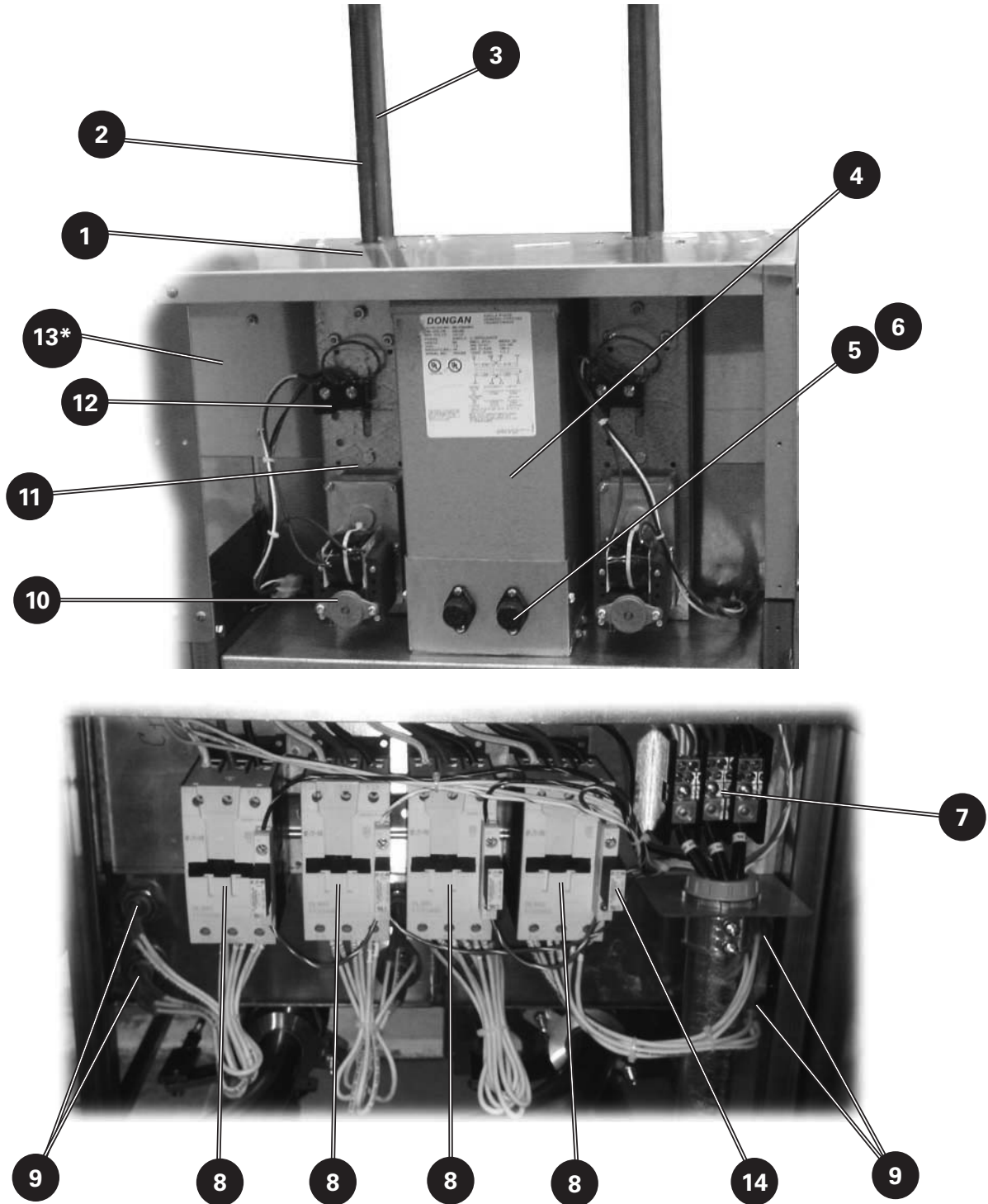

* Not shown

Parts List

EOF-10-10/FFLT/24, EOF-10-10/FFLT/24/24
 EOF-20/FFLT/24, EOF-20/FFLT/24/24

8-04. EOF-10-10 Rear Upper & Lower Cabinet

| Item | Part No. | Qty. | Description |
|------|----------|------|--|
| 01 | 39167 | 2 | BEARING, BRONZE, GROOVED |
| 02 | 35052 | 2 | BAR, ELEVATOR LIFT |
| 03 | 39403 | 2 | BASKET CARRIER ASSY |
| 04* | 20513 | 2 | CURCUIT BREAKER, 50A, 6-PL (208/240 ONLY)V |
| 04 | 24277 | 1 | TRANSFORMER, 1.5 KW 480V > 240V (480V ONLY) |
| 05 | 21950 | 2 | FUSE HOLDER, 300V, 15A, SC 0 >15 |
| 06 | 21900 | 2 | FUSE, 15-AMP, SC-15 |
| 07 | 21164 | 1 | TERMINAL BLOCK, POWER DISTRIBUTION |
| 08 | 20617 | 4 | CONTACTOR, 50A, 3-POLE, LONG-LIFE |
| 09 | 20359 | 4 | ELEMENT, 6000W, 480V, FIREBAR, EOF-10-10 |
| 09 | 20358 | 4 | ELEMENT, 6000W, 240V, FIREBAR, EOF-10-10 |
| 09 | 20357 | 4 | ELEMENT, 6000W, 208V, FIREBAR, EOF-10-10 |
| 10 | 36457 | 2 | BASKET LIFT MOTOR ASSEMBLY |
| 11 | 35166 | 2 | COMPLETE BASKET LIFT ASSEMBLY (includes motor) |
| 12 | 22878 | 2 | SWITCH, DBL. SNAP ACTION, 205V, 10A |
| 13* | 34971 | 1 | BACK PANEL, EOF-20 |
| 14 | 20568 | 4 | RC SUPPRESSOR |

* Not shown



8-05. EOF-20 Control Panel & Front Header

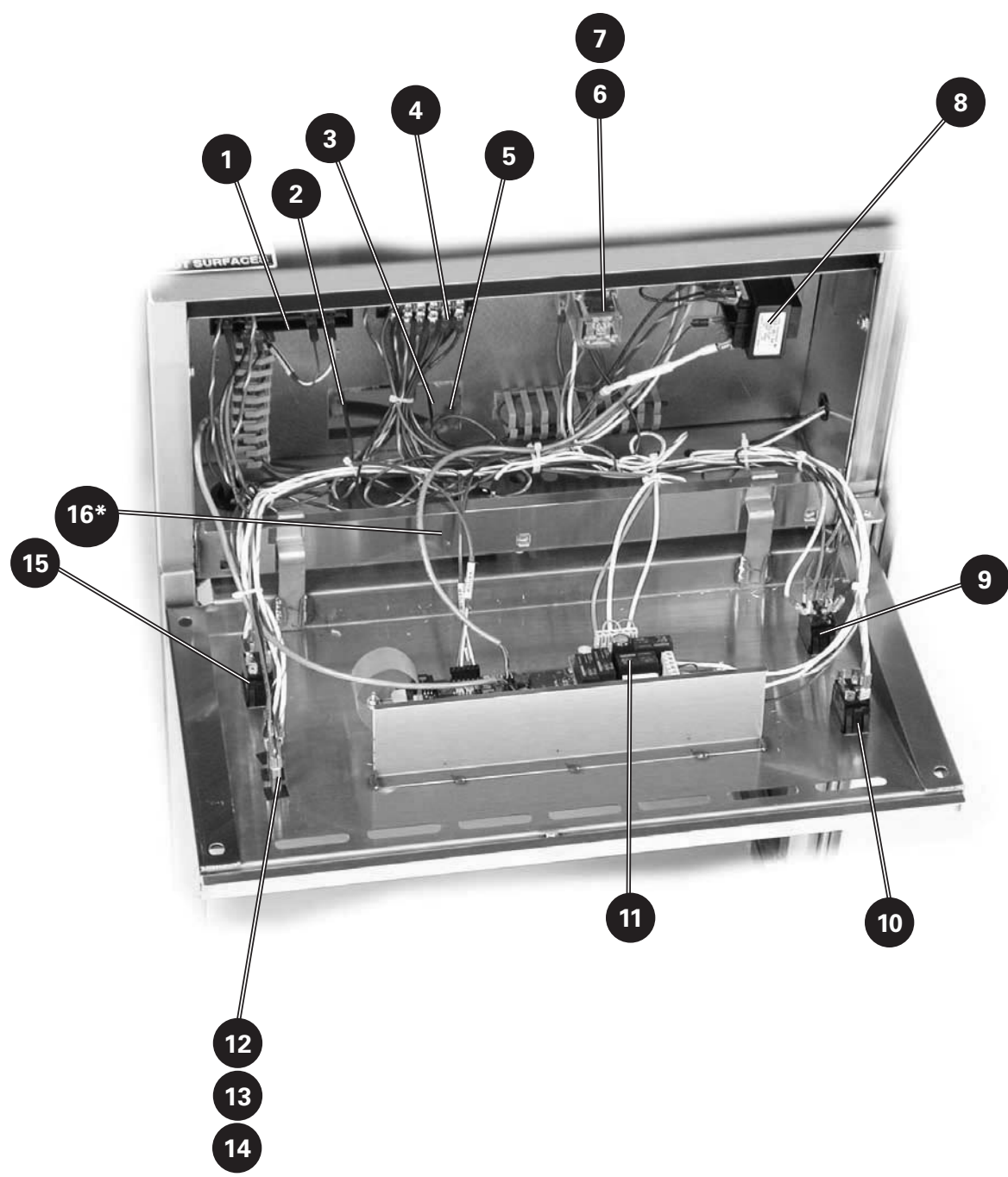

* Not shown

Parts List

EOF-10-10/FFLT/24, EOF-10-10/FFLT/24/24
 EOF-20/FFLT/24, EOF-20/FFLT/24/24

8-05. EOF-20 Control Panel & Front Header

| Item | Part No. | Qty. | Description |
|------|----------|------|--|
| 01 | 23755 | 1 | THERMOSTAT, SAFETY, WATLOW, 450DEG |
| 02 | 20315 | 1 | THERMOCOUPLE, 13.5", STRAIGHT, J TYPE, (REQUIRES P/N 45111 FERRULE) |
| 03 | 20315 | 1 | THERMOCOUPLE, 13.5", STRAIGHT, J TYPE, (REQUIRES P/N 45111 FERRULE) |
| 04 | 23751 | 1 | TERMINAL BLOCK, MA106, 6 POLE |
| 05 | 24222 | 1 | THERMOCOUPLE, VARIABLE, SINGLE, (REQUIRES P/N 45111 FERRULE) |
| 06 | 21101 | 1 | SOCKET, RELAY, 8 PIN, 300V, 10A, CR-5 |
| 07 | 21102 | 1 | RELAY, 8 PIN, 240V, 10A, CR-5 |
| 08 | 37616 | 1 | TRANSFORMER & ADAPTER PLATE, ASSY, 60HZ |
| 09 | 21190 | 1 | SWITCH, ROCKER, ON-OFF, 250V, 20A, DPST |
| 10 | 21052 | 1 | SWITCH, ROCKER, ON-NONE-ON, 250V, 20A, DPDT |
| 11 | 20326 | 1 | CONTROLLER, N7, WATLOW |
| 12 | 38214 | 1 | LIGHT, INDICATOR, RED, 250VAC |
| 13 | 38213 | 1 | LIGHT, INDICATOR, ORANGE, 250V |
| 14 | 38215 | 1 | LIGHT, INDICATOR, GREEN, 250VAC |
| 15 | 21052 | 1 | SWITCH, ROCKER, ON-NONE-ON, 250V, 20A, DPDT |
| 16* | 23782 | 1 | SONALERT, 250V, CONTINUOUS BEEP |

* Not shown



8-06. EOF-20 Front Lower Cabinet

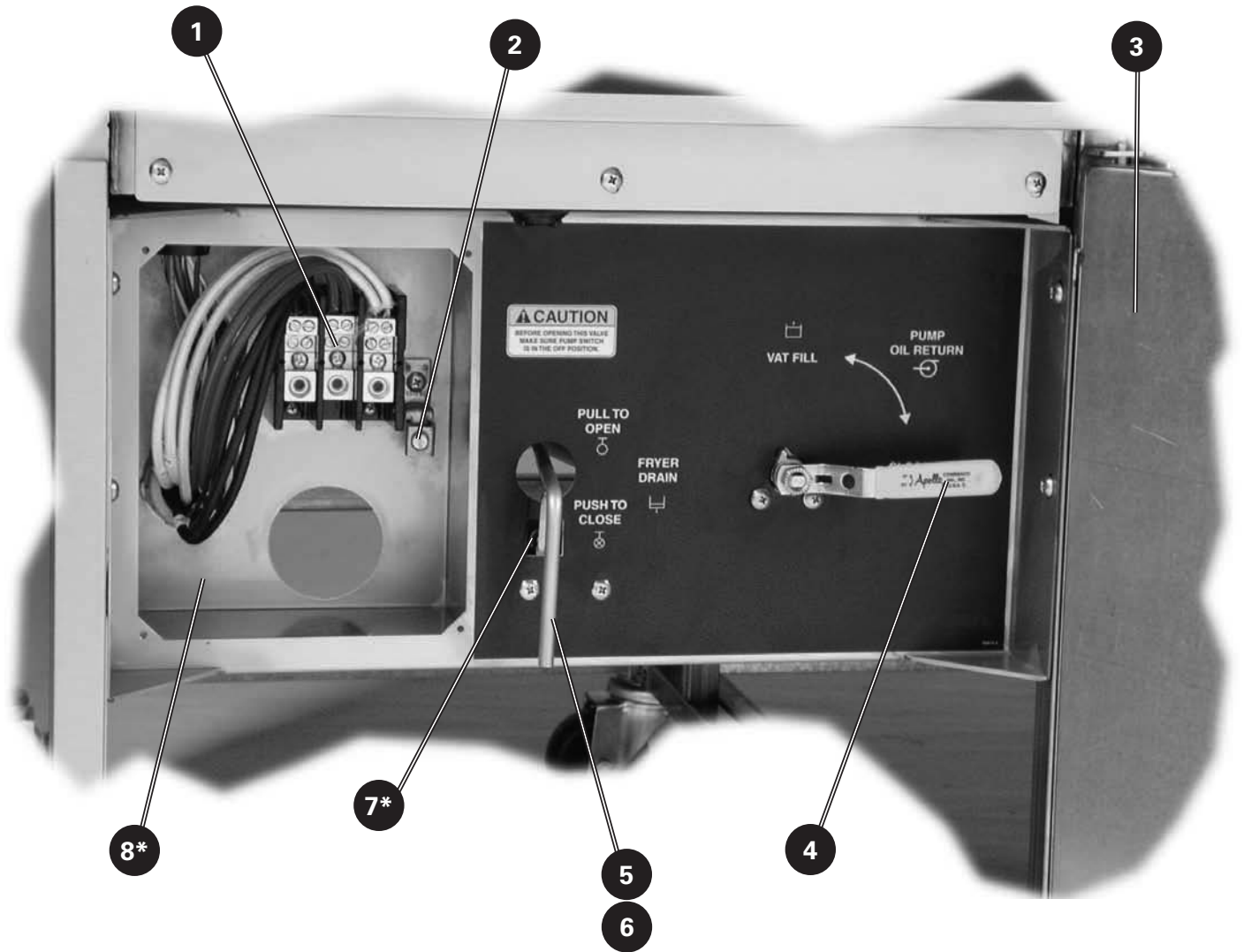

* Not shown

Parts List

EOF-10-10/FFLT/24, EOF-10-10/FFLT/24/24
EOF-20/FFLT/24, EOF-20/FFLT/24/24

8-06. EOF-20 Front Lower Cabinet

| Item | Part No. | Qty. | Description |
|------|----------|------|--|
| 01 | 21164 | 1 | TERMINAL BLOCK, POWER DIST. |
| 02 | 21051 | 1 | LUG, 1/0-2/0 COPPER TERMINAL 125A 1/4" BOLT HOLE |
| 03 | 35151 | 1 | DOOR ASSEMBLY |
| 04 | 40784 | 1 | VALVE, BALL, 1/2", S/S W/NON-STICK SEALS |
| 05 | 39258 | 1 | HANDLE, DRAIN PULL |
| 06 | 40818 | 1 | VALVE,BALL,1-1/4",DRAIN,SINGLE THREADEND |
| 07* | 21157 | 1 | SWITCH, LIMIT, 15A, 250V DRAIN SWITCH |
| 08* | 35236 | 1 | COVER, SERVICE CONNECTION |

* Not shown

8-07. EOF-20 Rear Lower Cabinet

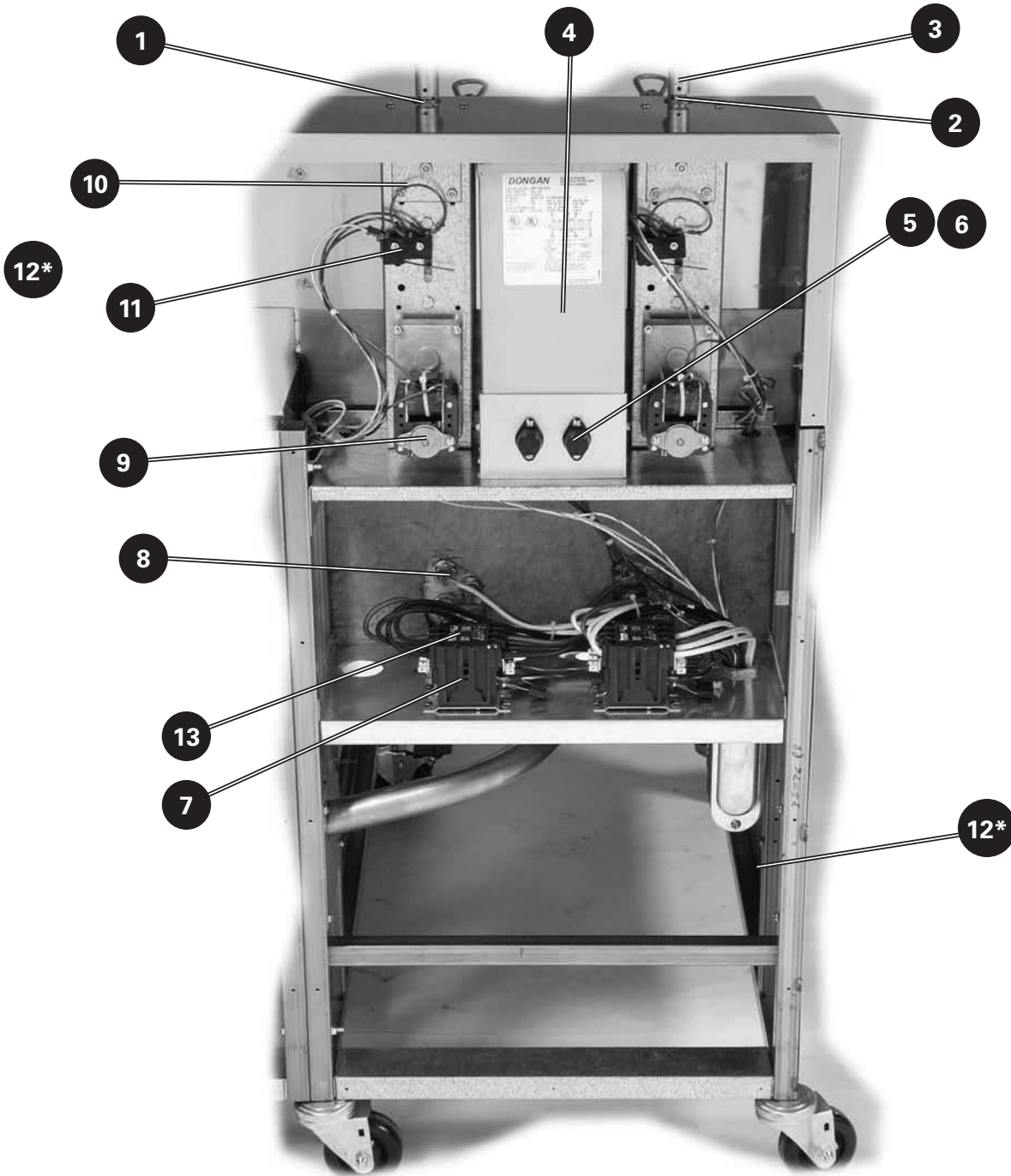

* Not shown

REF #: 60221-03

Parts List

EOF-10-10/FFLT/24, EOF-10-10/FFLT/24/24
 EOF-20/FFLT/24, EOF-20/FFLT/24/24

8-07. EOF-20 Rear Lower Cabinet

| Item | Part No. | Qty. | Description |
|------|----------|------|--|
| 01 | 39167 | 2 | BEARING, BRONZE, GROOVED |
| 02 | 35052 | 2 | BAR, ELEVATOR LIFT |
| 03 | 39403 | 2 | BASKET CARRIER ASSY |
| 04* | 20513 | 2 | CURCUIT BREAKER, 50A, 6-PL (208/240 ONLY)V |
| 04 | 24277 | 1 | TRANSFORMER, 1.5 KW 480V > 240V (480V ONLY) |
| 05 | 21950 | 2 | FUSE HOLDER, 300V, 15A, SC 0 >15 |
| 06 | 21900 | 2 | FUSE, 15-AMP, SC-15 |
| 07 | 20617 | 2 | CONTACTOR, 50A, 3-POLE, LONG-LIFE |
| 08 | 20003 | 4 | ELEMENT, ROUND, 6000W, 208V, EOF-20 |
| 08 | 20004 | 4 | ELEMENT, ROUND, 6000W, 240V, EOF-20 |
| 08 | 24257 | 4 | ELEMENT, ROUND, 6000W, 480V, EOF-20 |
| 09 | 36457 | 2 | BASKET LIFT MOTOR ASSEMBLY |
| 10 | 35166 | 2 | COMPLETE BASKET LIFT ASSEMBLY (includes motor) |
| 11 | 22878 | 2 | SWITCH, DBL. SNAP ACTION, 205V, 10A |
| 12* | 34971 | 1 | BACK PANEL, EOF-20 |
| 13 | 20568 | 2 | RC SUPPRESSOR |

* Not shown



8-08. EOF-24 Control Panel & Front Header

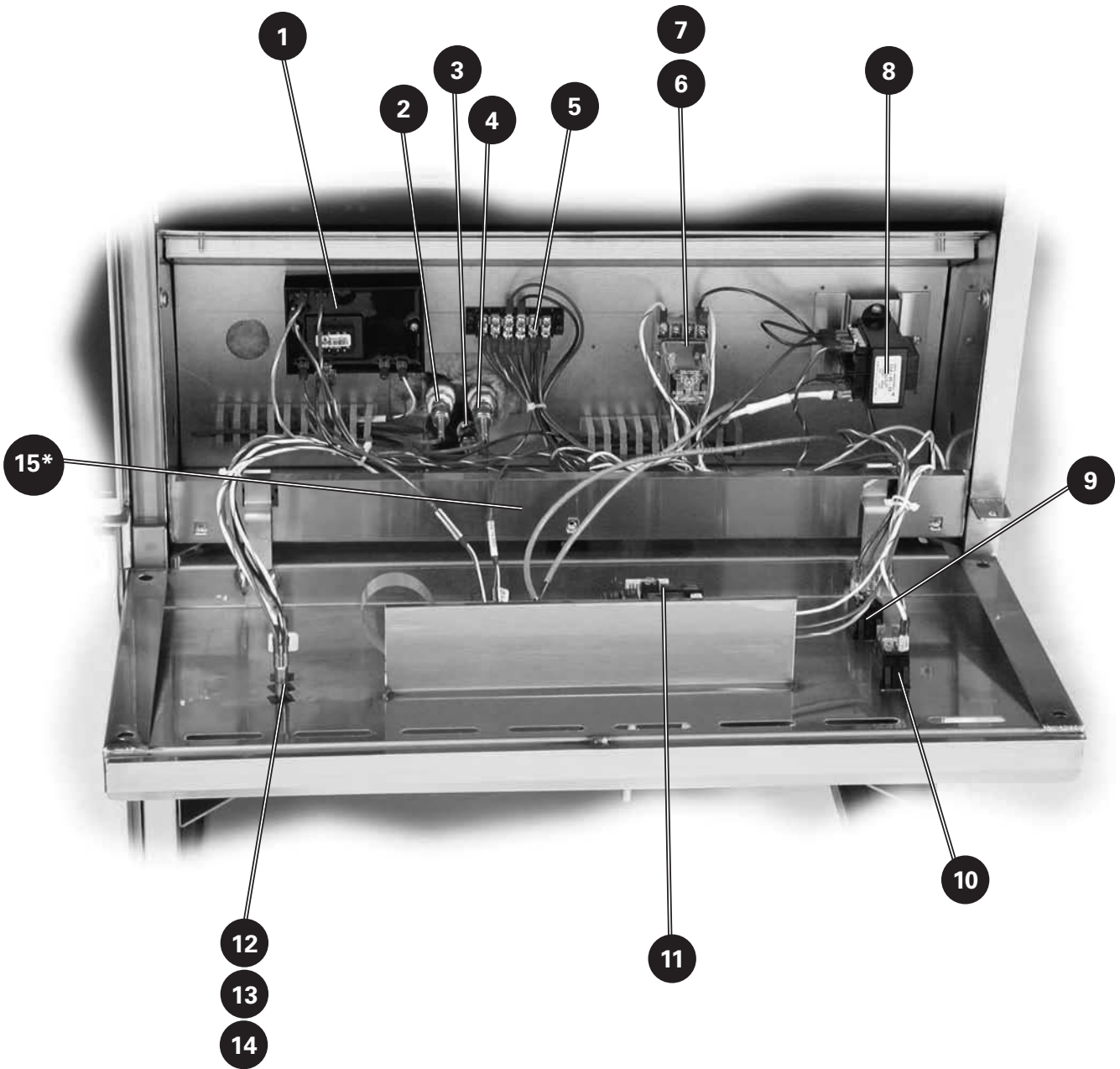

* Not shown

Parts List

EOF-10-10/FFLT/24, EOF-10-10/FFLT/24/24
EOF-20/FFLT/24, EOF-20/FFLT/24/24

8-08. EOF-24 Control Panel & Front Header

| Item | Part No. | Qty. | Description |
|------|----------|------|--|
| 01 | 23755 | 1 | THERMOSTAT, SAFETY, WATLOW, 450DEG |
| 02 | 20315 | 1 | THERMOCOUPLE, 13.5", STRAIGHT, J TYPE, (REQUIRES P/N 45111 FERRULE) |
| 03 | 24222 | 1 | THERMOCOUPLE, VARIABLE, SINGLE, WOG-D, (REQUIRES P/N 45111 FERRULE) |
| 04 | 20315 | 1 | THERMOCOUPLE, 13.5", STRAIGHT, J TYPE, (REQUIRES P/N 45111 FERRULE) |
| 05 | 23751 | 1 | TERMINAL BLOCK, MA106, 6 POLE |
| 06 | 21101 | 1 | SOCKET, RELAY, 8 PIN, 300V, 10A |
| 07 | 21102 | 1 | RELAY, 8 PIN, 240V, 10A |
| 08 | 37616 | 1 | TRANSFORMER & ADAPTER PLATE, ASSY, 60HZ |
| 09 | 21190 | 1 | SWITCH, ROCKER, ON-OFF, 250V, 20A, DPST |
| 10 | 21052 | 1 | SWITCH, ROCKER, ON-NONE-ON, 250V, 20A, DPDT |
| 11 | 20326 | 1 | CONTROLLER, N7, WATLOW |
| 12 | 38214 | 1 | LIGHT, INDICATOR, RED, 250VAC |
| 13 | 38213 | 1 | LIGHT, INDICATOR, ORANGE, 250V |
| 14 | 38215 | 1 | LIGHT, INDICATOR, GREEN, 250VAC |
| 15* | 23782 | 1 | SONALERT, 250V, CONTINUOUS BEEP |

* Not shown



8-09. EOF-24 Front Lower Cabinet



* Not shown

Parts List

EOF-10-10/FFLT/24, EOF-10-10/FFLT/24/24
EOF-20/FFLT/24, EOF-20/FFLT/24/24

8-09. EOF-24 Front Lower Cabinet

| Item | Part No. | Qty. | Description |
|------|----------|------|--|
| 01 | 21051 | 1 | LUG, 1/0-2/0 COPPER TERMINAL 125A 1/4" BOLT HOLE |
| 02 | 21164 | 1 | TERMINAL BLOCK, POWER DIST. |
| 03 | 35150 | 1 | DOOR ASSEMBLY (EOF24) |
| 04 | 35152 | 1 | DOOR ASSEMBLY (FFLT & RT. END EOF24 on 4-VAT) |
| 05* | 35236 | 1 | COVER, SERVICE CONNECTION |
| 06 | 40818 | 1 | VALVE,BALL,1-1/4",DRAIN,SINGLE THREADEND |
| 07 | 39260 | 1 | HANDLE,DRAIN PULL, WELD ASSY |
| 08 | 40784 | 1 | VALVE,BALL,1/2",S/S W/NON-STICK SEALS |

8-10. EOF-24 Rear Lower Cabinet

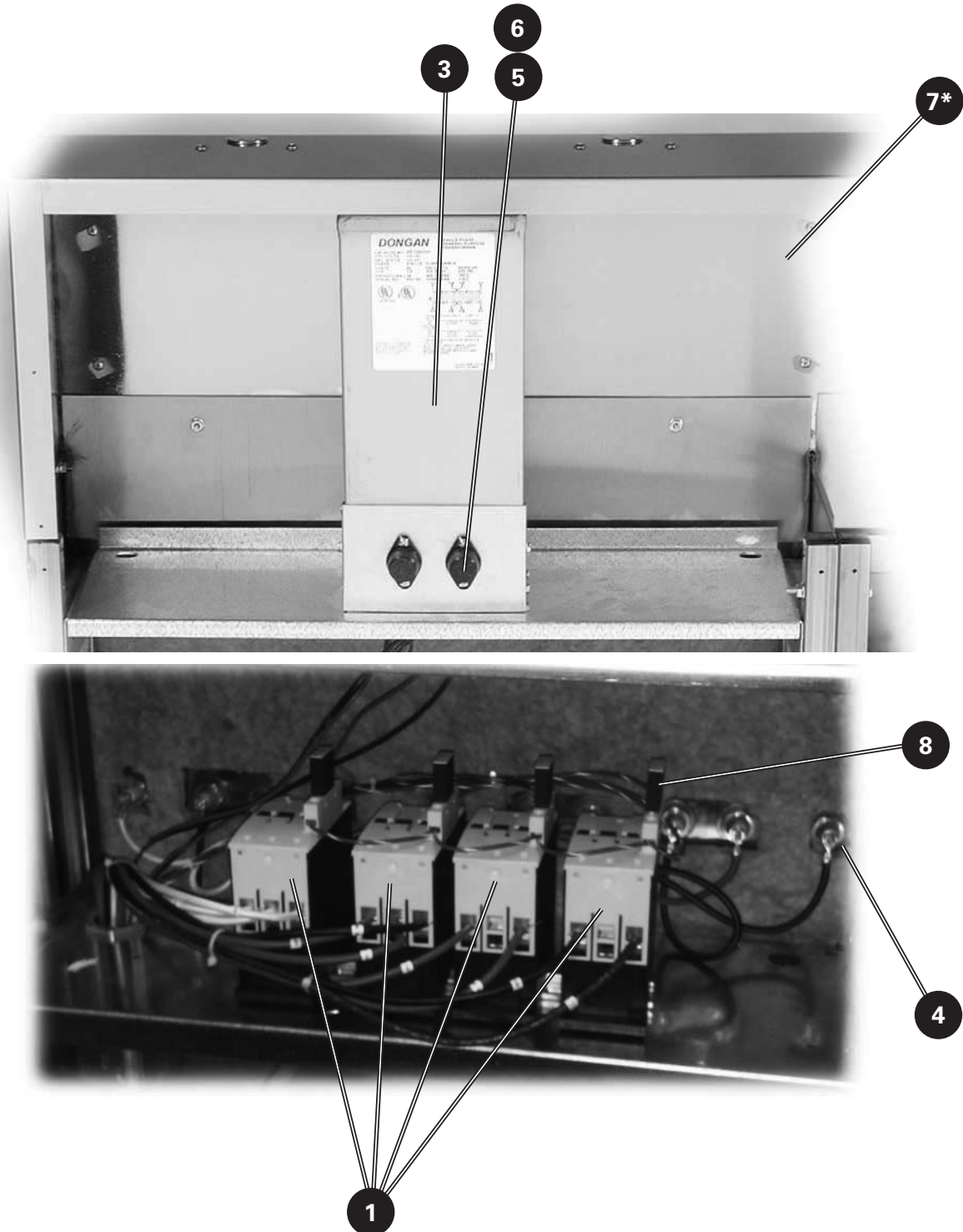

* Not shown

REF #: 60221-06

Parts List

EOF-10-10/FFLT/24, EOF-10-10/FFLT/24/24
EOF-20/FFLT/24, EOF-20/FFLT/24/24

8-10. EOF-24 Rear Lower Cabinet

| Item | Part No. | Qty. | Description |
|------|----------|------|---|
| 01 | 20617 | 4 | CONTACTOR, 50A, 3-POLE, LONG-LIFE |
| 02 | 35052 | 2 | BAR, ELEVATOR LIFT |
| 03* | 20513 | 2 | CURCUIT BREAKER, 50A, 6-PL (208/240 ONLY)V |
| 03 | 24277 | 1 | TRANSFORMER, 1.5 KW 480V > 240V (480V ONLY) |
| 04 | 20006 | 5 | ELEMENT, ROUND, 6000W, 240V, EOF-24 |
| 04 | 20005 | 5 | ELEMENT, ROUND, 6000W, 208V, EOF-24 |
| 04 | 24239 | 5 | ELEMENT, ROUND, 6000W, 480V, EOF-24 |
| 05 | 21950 | 2 | FUSE HOLDER, 300V, 15A, SC 0 >15 |
| 06 | 21900 | 2 | FUSE, 15-AMP, SC-15 |
| 07* | 34977 | 1 | BACK PANEL, EOF-24 |
| 08 | 20568 | 4 | RC SUPPRESSOR |

* Not shown

8-11. FFLT Front

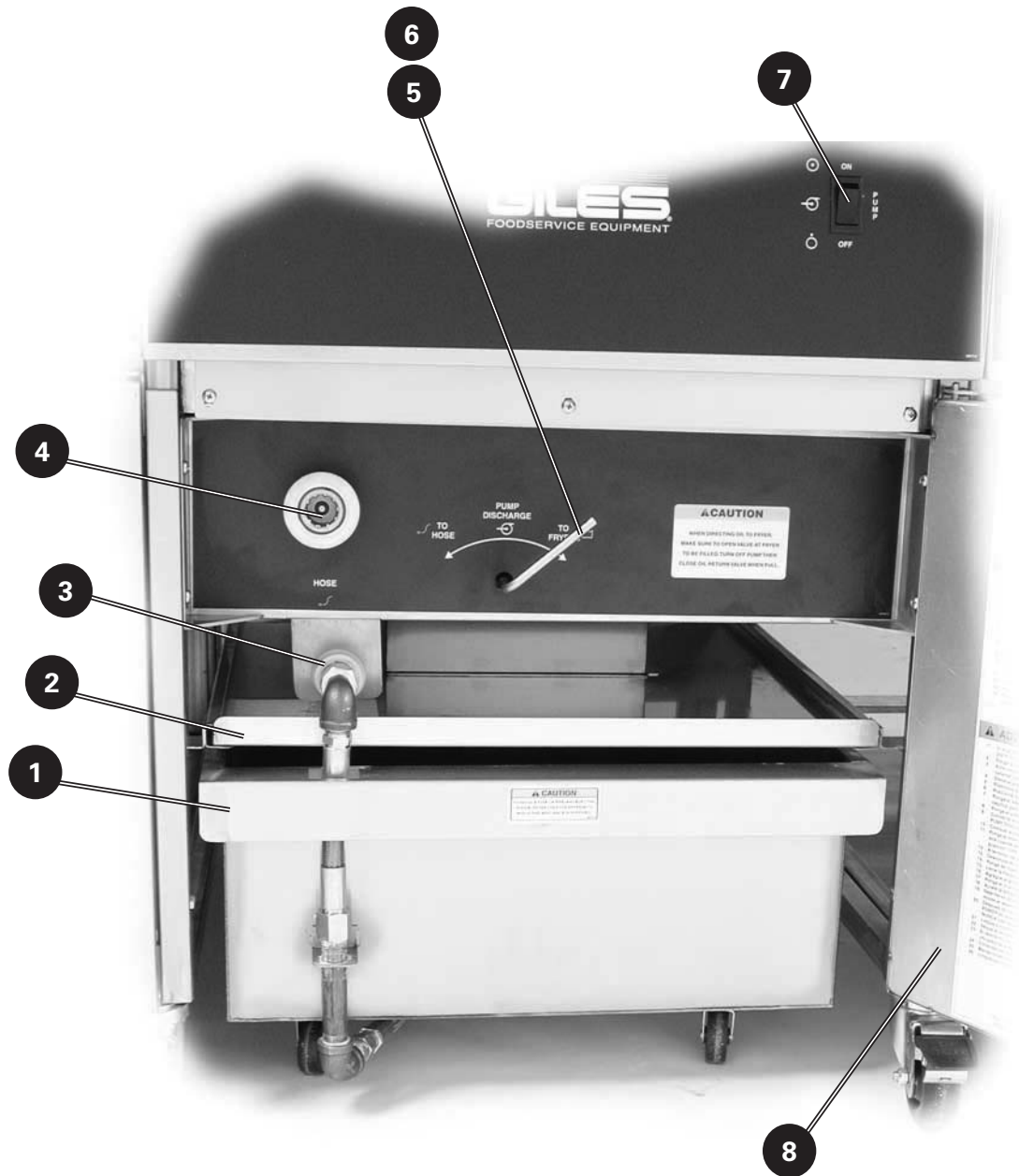

Parts List

EOF-10-10/FFLT/24, EOF-10-10/FFLT/24/24
EOF-20/FFLT/24, EOF-20/FFLT/24/24

8-11. FFLT Front

| Item | Part No. | Qty. | Description |
|------|----------|------|---|
| 01 | 35202 | 1 | FILTER PAN ASSEMBLY, EOF |
| 02 | 38994 | 1 | FILTER PAN COVER & HOUSING ASSEMBLY |
| 03 | 41900 | 1 | COUPLING, QUICK DISCONNECT, FEMALE |
| 04 | 41699 | 1 | COUPLING, QUICK DISCONNECT, FEMALE |
| 05 | 35108 | 1 | WELD ASSY., DIVERTER VALVE HANDLE |
| 06 | 45755 | 1 | VALVE, 3-WAY, 1/2NPT, NICKEL PLATED |
| 07 | 21052 | 1 | SWITCH, ROCKER, ON-NONE-ON, 250V, 20A, DPDT |
| 08 | 35152 | 1 | DOOR ASSEMBLY, FFLT |



8-12. FFLT Rear



* Not shown

Parts List

EOF-10-10/FFLT/24, EOF-10-10/FFLT/24/24
EOF-20/FFLT/24, EOF-20/FFLT/24/24



8-12. FFLT Rear

| Item | Part No. | Qty. | Description |
|------|----------|------|-----------------------|
| 01* | 34970 | 1 | BACK PANEL |
| 02 | 70912 | 1 | PUMP & MOTOR ASSEMBLY |
| 03 | 70910 | 1 | PUMP HEAD ONLY |
| 04 | 70911 | 1 | PUMP MOTOR ONLY |

8-13. Filter Pan

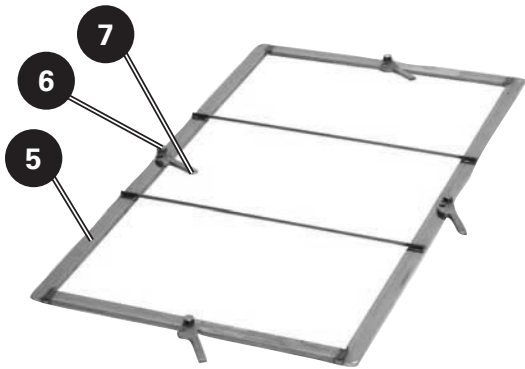

**NOTE: PERMANENT SUPPORT
SCREEN ... NOT A REMOVABLE
ITEM.**

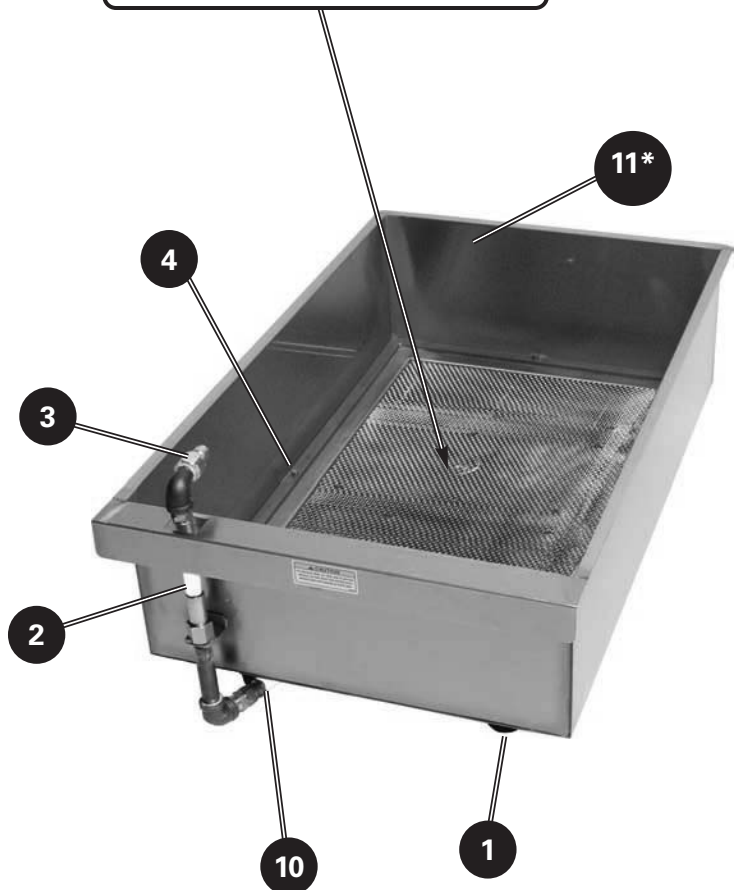
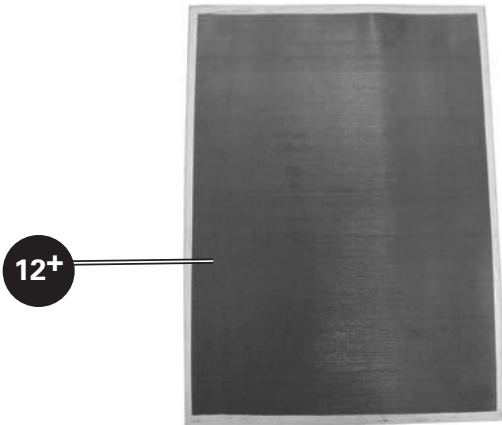
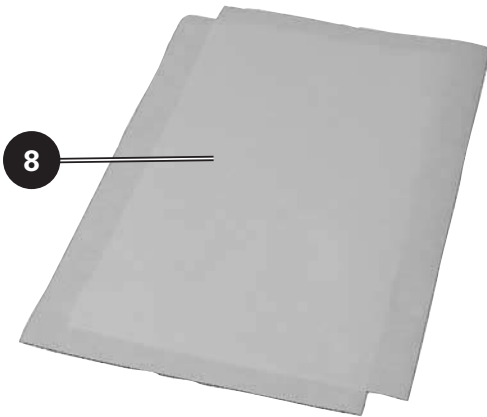

* Complete assembly
+ Optional Item

Parts List

EOF-10-10/FFLT/24, EOF-10-10/FFLT/24/24
EOF-20/FFLT/24, EOF-20/FFLT/24/24

8-13. Filter Pan

| Item | Part No. | Qty. | Description |
|------|----------|------|--|
| 01 | 40649 | 4 | CASTER, LOW PROFILE, PLATE MOUNT |
| 02 | 40959 | 1 | HOSE, 1/2NPT X 7-5/8, SCT, 1-END SWIVEL |
| 03 | 44150 | 1 | FITTING, BRASS,MALE,1/2NPT, QUICK-DISCONNECT |
| 04 | 30039-8 | 4 | STUD, FILTER PAN SUPPORT FRAME |
| 05 | 36772 | 1 | HOLD-DOWN FRAME |
| 06 | 30040-4 | 4 | STUD, FILTER PAN HOLD-DOWN FRAME |
| 07 | 54526 | 4 | LEVER, FILTER PAN HOLD-DOWN FRAME |
| 08 | 60328 | 1 | PAPER FILTER MEDIA, 19-3/8 X 32-3/8 (100 CT. CASE) |
| 09 | 36212 | 1 | CRUMB CATCHER SCREEN, FILTER PAN INSERT |
| 10 | 40958 | 1 | HOSE, 1/2NPT X 18, SCT, 1-END SWIVEL |
| 11* | 35202 | 1 | FILTER PAN COMPLETE ASSEMBLY (#36121 not included) |
| 12+ | 41017 | 1 | REUSABLE, RENEWABLE FILTER SCREEN, 19.375 X 32.375 (Optional Item) |

* Complete assembly

+ Optional Item

Note: The permanent perforated screen eliminated the need for P/N 40367, Filter Pan Screen, however, 40367 is still required for Filter Pans and/or units manufactured before Dec. 2009.



Notes:





Giles Enterprises, Inc.

2750 Gunter Park Drive West • Montgomery, Al 36109 USA
(334) 272-1457 • Service Hotline 800-554-4537 (USA & Canada Only) • FAX (334) 239-4117 • www.gfse.com • e-mail: services@gfse.com

Form No. 60221 (Release date: 11/99) Revised: 07/15/12, Rev. E)