



## Giles Enterprises, Inc.

2750 Gunter Park Drive West • Montgomery, AL 36109 USA

Fax: (334) 272-3561 • Internet: [www.gilesent.com](http://www.gilesent.com)

Service Hotline (Toll Free): 1-800-554-4537 (USA & Canada Only)

Form No. 60347 (Release date: 11/99)(Revision date: 11/06/07)(Rev. B)



## LIMITED WARRANTY

- Subject to the terms and conditions of this Limited Warranty as herein stated, all Giles Enterprises, Inc., Foodservice Equipment and parts purchased new from an authorized Giles Enterprises, Inc., representative are warranted as to defects in material or workmanship for a period of 12 months from the date of installation, provided, however, that with regard to labor costs in connection with this warranty, see below. All installations must be made by a qualified installing agency in accordance with all applicable codes and/or regulations in the jurisdiction in which installed. Limited warranty coverage is extended to the original owner only and is void if the unit is resold.
- During the Limited Warranty period, Giles Enterprises, Inc. will replace or recondition, at its factory, any part or parts of this unit which Giles Enterprises, Inc. inspectors judge defective, provided the unit has been subjected to normal usage, properly installed, operated and serviced. This Limited Warranty does not cover cosmetic damage, and damage due to acts of God, accident, misuse, alteration, negligence, abuse of the Giles Foodservice Equipment or the use of unorthodox repair methods. All parts replaced under this Limited Warranty carry only the unexpired term of this Limited Warranty. Limited Warranty service may be furnished only by an authorized Giles Enterprises, Inc., representative.
- If Limited Warranty service is requested, Giles Enterprises, Inc., will send factory-authorized service representatives to repair, recondition, replace or inspect units of its manufacture with such labor being rendered without cost to owner for ninety (90) days from the date of installation. Otherwise, service, including labor and transportation charges or other expenses, in connection with the removal or installation of any part or parts supplied under this Limited Warranty, are specified on the original sales contract between the purchaser and the authorized Giles Enterprises, Inc., representative.
- Giles Enterprises, Inc. reserves the right to change or improve its equipment and parts in any way without obligation to alter such equipment or parts previously manufactured.
- Giles Enterprises, Inc. makes no further warranties, express or implied including implied warranties of merchantability or fitness for a particular purpose, and has no other obligation or liability not specifically stated herein.
- Repair or replacement as provided under this limited warranty is the exclusive remedy. Giles Enterprises, Inc., shall not be liable for any incidental or consequential damages for breach of any express or implied warranty on this product, except to the extent prohibited by applicable law. Any implied warranty of merchantability or fitness for a particular purpose on this product is limited in duration to the duration of this limited warranty.
- Used Giles Enterprises, Inc., Foodservice Equipment or parts or Giles Enterprises, Inc., Foodservice Equipment or parts not purchased from an authorized Giles Enterprises, Inc., representative, carry no warranties, express or implied.



<b>Safety</b> .....	<b>vii</b>
Safety Overview .....	vii
Specific Safety Precautions .....	viii
<b>1. Introduction</b> .....	<b>1</b>
1-01. Construction .....	1
1-02. Standard Features .....	1
1-03. Optional Features .....	1
1-04. Specifications .....	2
1-04.1. Overall Dimensions for EOF 20/20 .....	2
1-04.2. Regulatory Listings .....	3
1-04.3. Basket Size .....	3
1-04.4. Vat Size and Capacity .....	3
1-04.5. Shipping Specifications (Crated) .....	3
<b>2. Installation</b> .....	<b>5</b>
2-01. Location .....	5
2-02. Unpacking .....	6
2-03. Electrical Requirements .....	7
2-03.1. EOF 20/20 Electrical Specifications .....	7
2-04. Electrical Connections .....	7
2-04.1. Electrical Connections Diagram .....	8
2-05. Ventilation of Fryer .....	8
<b>3. Overview</b> .....	<b>9</b>
3-01. EOF-20 Basket Elevator and Baskets .....	10
3-02. EOF-20 Control Panel .....	12
3-03. EOF-20 Left Lower Cabinet Area .....	14
3-04. EOF-20 Right Lower Cabinet Area .....	16
3-05. EOF-20 Basket Elevator and Baskets .....	18
3-06. Filter Pan Assembly .....	20
3-07. Accessories (Included) .....	22
3-08. Accessories (Not Included) .....	25
<b>4. Unit Preparation</b> .....	<b>27</b>
4-01. Settings before each test .....	27
4-02. Power test .....	29
4-03. Heating Element test .....	30
4-04. Filter Pump Test .....	31
4-05. Perform Boil Out Procedure .....	32
4-06. Clean Filter Pan .....	32

<b>5.</b>	<b>Fryer Operation . . . . .</b>	<b>33</b>
5-01.	Cooking Controller . . . . .	34
5-01.1.	Buttons and Functions . . . . .	35
5-01.2.	Programming the Cooking Temperature . . . . .	36
5-01.3.	Programming a Cooking Time . . . . .	37
5-01.4.	Start a cooking time . . . . .	38
5-01.5.	Cancel the currently running cooking time . . . . .	38
5-01.6.	Manually lowering and raising the cooking basket (Basket Elevator Only) . . . . .	38
5-01.7.	Displaying remaining cooking time . . . . .	39
5-01.8.	Displaying the actual temperature of the liquid shortening . . . . .	39
5-02.	Cooking Procedure . . . . .	40
5-03.	Filtering Liquid Shortening . . . . .	45
5-04.	Removal of Liquid Shortening . . . . .	48
5-05.	Normal Shut-Down . . . . .	51
5-06.	Emergency Shut-Down . . . . .	51
<b>6.</b>	<b>Cleaning . . . . .</b>	<b>53</b>
6-01.	Boil-Out Procedure (Cleaning the Fry Pot) . . . . .	53
6-02.	Cleaning the Filter Pan and replacing Filter Paper after Boil Out . . . . .	56
6-03.	Cleaning the Filter Pan and replacing the Filter Paper daily . . . . .	57
<b>7.</b>	<b>Troubleshooting . . . . .</b>	<b>59</b>
7-01.	Temperature Control System . . . . .	59
7-02.	Oil Filtration System . . . . .	61
7-03.	Basket Elevator System (Basket Elevator Option Only) . . . . .	62
<b>8.</b>	<b>Parts List . . . . .</b>	<b>63</b>
8-01.	Parts Ordering and Service Information . . . . .	63
8-02.	EOF-20 Left Control Panel & Front Header . . . . .	64
8-03.	EOF-20 Left Front Lower Cabinet . . . . .	66
8-04.	EOF-20 Left Rear Lower Cabinet . . . . .	68
8-05.	EOF-20 Right Control Panel & Front Header . . . . .	70
8-06.	EOF-20 Right Front Lower Cabinet . . . . .	72
8-07.	EOF-20 Right Rear Lower Cabinet . . . . .	74
8-08.	Filter Pan . . . . .	76
<b>9.</b>	<b>Wiring Diagram . . . . .</b>	<b>79</b>
9-01.	Wiring Diagram EOF-20/20 Left Fryer 208-240/60/3 Computer . . . . .	80
9-02.	Wiring Diagram EOF-20/20 Right Fryer 208-240/60/3 Computer . . . . .	82
9-03.	Wiring Diagram EOF-20/20 Left Fryer 480/60/3 Computerr . . . . .	84
9-04.	Wiring Diagram EOF-20/20 Right Fryer 480/60/3 Computer . . . . .	86





**Notes:**



## Safety

### Safety Overview

The instructions contained in this manual have been prepared to aid you in learning the proper procedures for installing and servicing your unit.

Throughout this manual, safety precautions are identified through the use of the safety alert symbol and three signal words: **DANGER**, **WARNING**, and **CAUTION**. All safety alert information precedes the step(s) to which they apply. Suggested, recommended, or other noteworthy information is identified through the use of **NOTES**. Additionally, certain words are used to indicate a specific meaning or to add emphasis.

The following words are used as indicated throughout the manual:

**Shall:** understood to be mandatory.

**Should:** understood to be advisory.

**May:** understood to be permissive.

**Will:** indicates a future event/condition to occur.

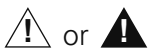

(Safety Alert Symbol)

Used in conjunction with signal words (**DANGER**, **WARNING**, or **CAUTION**) to alert you of potential personal injury hazards, immediately preceding precautionary measures that pertain to subsequent step(s). Obey all safety messages that follow these symbols to avoid possible injury or death. Failure to adhere to safety precautions identified by the safety alert symbol may also void the warranty.

#### **DANGER**

- Indicates an imminently hazardous situation which, if not avoided, will result in death or serious injury. Use of this is limited to the most extreme situations.

#### **WARNING**

- Indicates a potentially hazardous situation which, if not avoided, could result in death or serious injury.

#### **CAUTION**

- Indicates a potentially hazardous situation which, if not avoided, may result in minor or moderate injury. Also used to alert against unsafe practices.

#### **CAUTION**

- When used without the safety alert symbol, **CAUTION** indicates a potentially hazardous situation which, if not avoided, may result in equipment/property damage, and void the warranty.

#### **NOTE:**

- Identifies suggested, recommended, or other noteworthy information.

**Specific Safety Precautions**

For your safety, please observe the following precautions when operating or servicing this unit. Read the following important safety information to avoid personal injury and/or damage to the equipment.

**⚠ DANGER**

- Turn off the unit and unplug the power cord before cleaning or performing maintenance.
- **DO NOT** hose down the unit’s interior or exterior with water.
- Failure to comply with these **DANGER** notices will result in death or serious injury, equipment/property damage, and void the warranty.

**⚠ WARNING**

- Consult a qualified electrician to ensure that:
  - all electrical specifications and codes are met.
  - circuit breakers and wiring are of sufficient rating and gauge.
- The unit must be properly grounded and all electrical specifications must be met during installation.
- Improper installation, adjustment, alteration, service or maintenance could result in death or serious injury, equipment/property damage, and void the warranty.
- **DO NOT** use or store gasoline or other flammable liquids or vapors in the vicinity of this or any other electrical appliance!
- Failure to comply with **WARNING** notices could result in death or serious injury and equipment/property damage and void the warranty.

**⚠ CAUTION**

- The unit must remain in the upright (vertical) position.
- Exercise care when removing the wooden crate from around the unit.
- **DO NOT** operate the unit unless you fully understand the components and their intended functions (see Section 3).
- The unit and its parts are HOT!  
Exercise caution when operating, loading/unloading food, cleaning or servicing.  
Wearing of thermal oven mitts is recommended.
- Failure to comply with **CAUTION** notices may result in minor or moderate injury, equipment/property damage, and void the warranty.

## CAUTION

- Food products must be maintained at a temperature of 150°F (65.5°C) minimum or in accordance with local or state health regulations.
- **Fryers must be adequately and properly grounded. Improper grounding may result in electrical shock. Always refer to your local electrical code to ensure proper grounding of this or any other electrical equipment. Always consult with an electrician or other qualified service person to ensure breakers and wiring are of sufficient rating and gauge for the equipment being operated.**
- Giles Electric Fryers are available from the factory wired for various voltages, phase and hertz. Check the rating plate on the front of the fryer to determine the correct power supply.
- Ensure the fry kettle is positioned in a secure, safe location with the casters in the locked position.
- Consult an electrician to ensure all electrical specifications have been met and the unit is properly grounded. The wiring diagrams contained in this manual should aid your electrician in the installation of your fryer.
- Due to the high temperature of shortening in your fryer during cooking, it is extremely important the user exercise caution in the operation of this equipment to avoid personal injury.
- Before attempting to operate the unit, refer to Section 3 to familiarize yourself with the various control functions.
- Be careful not to puncture the filter paper when using the brush to unclog the Drain Valve.
- Allow the unit to cool down a minimum of 15 minutes before cleaning or servicing.

## CAUTION

- The electronic components of the Control Panel are impact-sensitive. Exercise care around the Control Panel to maintain proper operation.
- **DO NOT** install the unit next to combustible walls and materials. Failure to maintain safe distances may result in fire.
- During cleaning of the unit:
  - **DO NOT** steam clean.
  - **DO NOT** use products containing chlorine.
  - **DO NOT** use abrasive products, steel wool or scouring pads.
  - **DO NOT** use oven cleaner.
- Failure to comply with these **CAUTION** notices may result in equipment/property damage and void the warranty.
- Failure to comply with these **CAUTION** notices may violate local health codes.
- **DO NOT** Modify, Alter or Add Attachments to this Equipment!

**NOTE:**

- If the crate in which the unit is shipped is damaged upon receipt, immediately inspect the unit and notify the carrier of any damage to the unit.
- To aid the electrician, an electrical wiring diagram is contained in this manual. Refer to the wiring diagram during installation or servicing.
- Comply with all appropriate state and/or local health regulations regarding the cleaning and sanitation of equipment.

## 1. *Introduction*

Congratulations on the purchase of your new Giles equipment, Model EOF-20/20 manufactured by Giles Enterprises, Inc., Montgomery, Alabama (USA), hereafter referred to as "Giles". Every unit is thoroughly inspected and tested prior to shipment. Proper care and maintenance will ensure years of trouble-free service.

To help protect your investment in this state-of-the-art cooking equipment, we recommend you take a few moments to familiarize yourself with the installation, cleaning and maintenance procedures contained in this manual. Adherence to these recommended procedures minimizes the potential for costly "Down-Time" and equipment repairs. Please retain this manual for future reference.

### 1-01. Construction

Model EOF-20/20, exterior and fry vats are constructed of stainless steel.

### 1-02. Standard Features

**Temperature Controller** -used to control the temperature of the cooking oil and the cooking time.

**Oil Filtration System** -used to extend the life of cooking oil.

### 1-03. Optional Features

**Automatic Basket Lift** -used to automatically lift cooked product from hot cooking oil at the end of the cooking cycle.

1-04. Specifications

1-04.1. Overall Dimensions for EOF 20/20

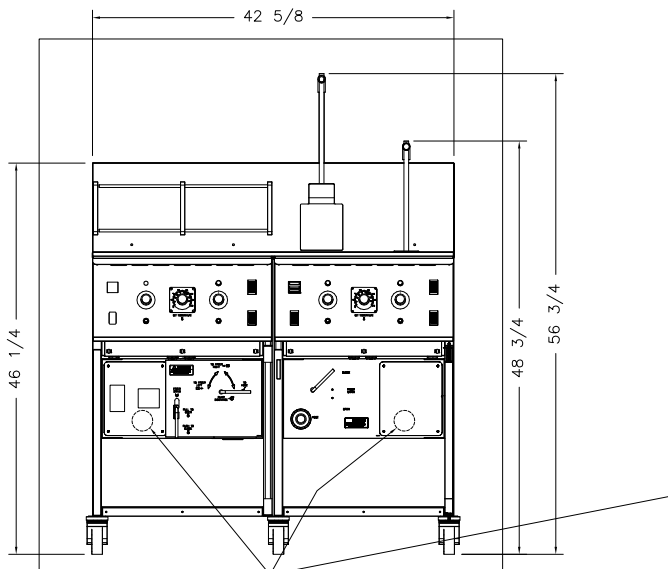

ELECTRICAL SERVICE CONNECTION

FRONT VIEW WITH DOORS OPEN

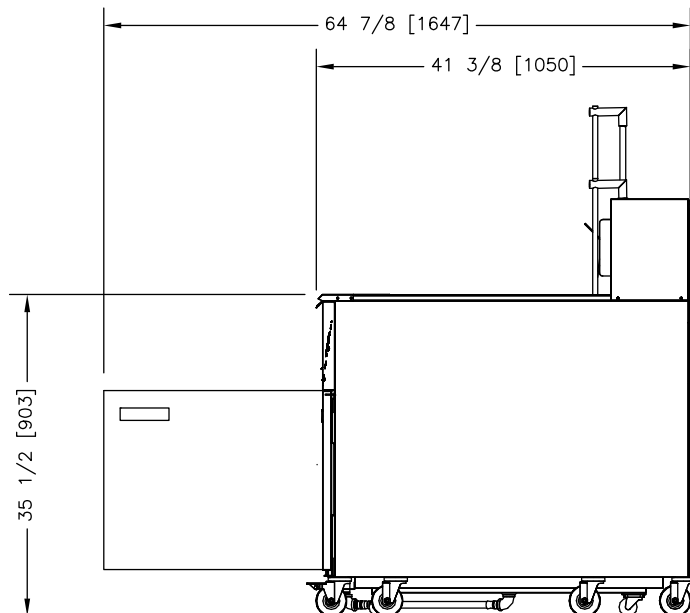

INCHES [MILLIMETERS]

<b>1-04.2. Regulatory Listings</b>	
UL (US and Canada) UL Sanitation	

<b>1-04.3. Basket Size</b>								
Model	Basket Size						Volume	
	Length		Width		Height		cubic inch	cubic meter
	in	mm	in	mm	in	mm		
EOF-20	9.00	228.6	18.50	469.9	5.5	139.7	811	0.013

<b>1-04.4. Vat Size and Capacity</b>										
Model	Length (Inside)		Width (Inside)		Height (Top of element to oil level line)		Liquid Shortening Capacity (Bottom of Vat to Oil level)			
	In	mm	In	mm	In	mm	Lbs	Kg	Gal	Lt
EOF-20	20	508	20	508	4 1/2	114	110	50	16	59

<b>1-04.5. Shipping Specifications (Crated)</b>										
Model	Net Weight		Crated Size						Volume	
	Lbs	Kg	Length		Width		Height		Cubic Feet	Cubic Meters
			In	mm	In	mm	In	mm		
EOF 20/20	884	401	76	1930	50	1270	61	1549	134.1	3.8



---

**Notes:**



## 2. Installation

This section provides a summary of the procedures necessary for proper installation of your new unit. To prevent personal injury or equipment damage, please ensure the following steps are taken.

### 2-01. Location

 **CAUTION**

- **DO NOT MODIFY, ALTER OR ADD ATTACHMENTS TO THIS EQUIPMENT**

1. Keep the appliance and surrounding area free and clear from combustible materials. {(3")(7.6cm) for Fryer.}
2. Please note wiring diagrams for this appliance are located in the rear of this manual. Ensure the wiring diagram corresponds with the model being operated.
3. Please ensure this appliance is electrically grounded in accordance with local codes, or in the absence of local codes, with the National Electrical Code, ANSI/NFPA NO. 70-1999.
4. Please provide adequate room for servicing and proper operation of this appliance. Also, provide adequate ventilation in the operating area where necessary.
5. Always consult with an electrician or other qualified individual prior to installation.
6. Ensure voltage and amperage supplied to the unit are as specified on the fryer's rating plate.
7. Make sure this unit is in a secure position and will not move. Locking casters are supplied on this unit—use them!
8. This appliance is to be installed, used and maintained in accordance with the Standard for Ventilation Control, and Fire Protection of Commercial Cooking Operations, NFPA 96-1994.

Compliance with the above steps will help to ensure safe and proper installation of your fryer. If you have any questions concerning these procedures, contact your local Giles distributor or other qualified service person.

**2-02. Unpacking**

Your Giles Fryer may arrive enclosed by a wooden crate. The Fryer is secured to a wooden platform by means of high-tensile strength strapping.

**⚠ CAUTION**

- Exercise care when lifting or moving the unit.
- Exercise care when removing the wooden crate from around the unit.
- Failure to comply with these CAUTION notices may result in minor or moderate injury, equipment/property damage, and void the warranty.

**NOTE:**

- If crate is damaged, immediately inspect the unit and notify the carrier of any damage to the unit.

1. Carefully cut and remove the plastic shipping wrap and the strapping mentioned above.
2. Use pliers to loosen wire hooks which secure the wooden crate around the fryer. Remove the wooden crate.
3. Carefully remove the fryer from the shipping platform. Your new fryer is extremely heavy, the uncrated weight for the EOF-20/20 is 584 lbs (265 kg), only use a fork lift when lifting this equipment, refer to 2-03.

## 2-03. Electrical Requirements

**⚠ CAUTION**

- **Fryers must be adequately and properly grounded. Improper grounding may result in electrical shock. Always refer to your local electrical code to ensure proper grounding of this or any other electrical equipment. Always consult with an electrician or other qualified service person to ensure breakers and wiring are of sufficient rating and gauge for the equipment being operated.**

The EOF-20/20 is available from the factory in the voltages and phases listed below. Check the rating plate on the rear of the fryer to determine the correct power supply.

### 2-03.1. EOF-20 Electrical Specifications

Voltage	Phase	Watts	Amps			Circuit Breaker required
			L1	L2	L3	
208	1	24,000	115	115	—	150
208	3	24,000	72	46	72	80
240	1	24,000	100	100	—	125
240	3	24,000	68	44	68	75
480	3	24,000	34	22	34	50

## 2-04. Electrical Connections

1. Install appropriate Circuit Breakers in Main Breaker Box! See Table 2-04.
2. Connect Flexible Conduit from Main Breaker Box to Quick Disconnect Box.
3. Connect Flexible Conduit from Quick Disconnect Box to the Fryer. Allow enough Conduit so Fryer can be moved away from the wall for cleaning and servicing. See Figure 2-05.1.
4. Open Fryer Door and remove Service Box Cover. See Figure 2-05.1.
5. Connect the electrical ground wire between the Terminal Block Ground Lug and a proper earth ground.
6. Route appropriate size Power Wires to the Fryer.
7. Connect the Power Wires to the appropriate Terminal Blocks located in the Service Box. See Figure 2-04.1.
8. Reinstall Service Box Cover and close the Fryer Door.

### 2-04.1. Electrical Connections Diagram

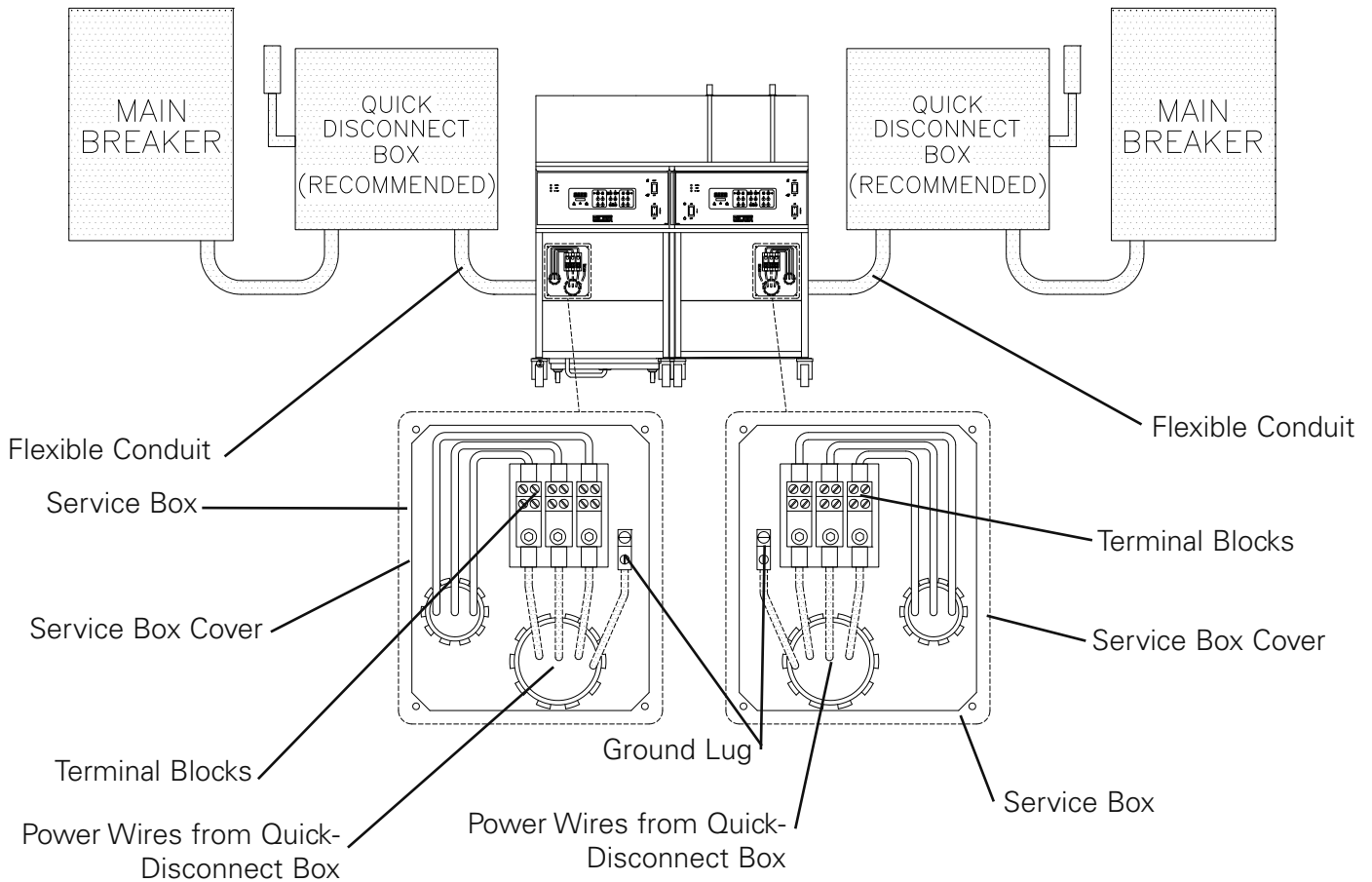

### 2-05. Ventilation of Fryer

**NOTE:**  
•Guidelines for proper ventilation system requirements differ from location to location. Always consult with local authorities to ensure compliance.

Consult a professional ventilation or heating and air conditioning company for assistance in designing a Ventilation hood for this unit.

3. Overview

The following section provides a brief overview of the components, functions, and accessories of the unit. Please review this section carefully before proceeding any further.

EOF-20 Baskets and Basket Hanger Figure 3-07.

EOF-20 Baskets and Basket Lift Figure 3-04.



EOF-20 Control Panel Figure 3-05.

EOF-20 Lower Cabinet Area Figure 3-06.

Filter Pan Assembly Figure 3-08.

3-01. EOF-20 Basket Elevator and Baskets

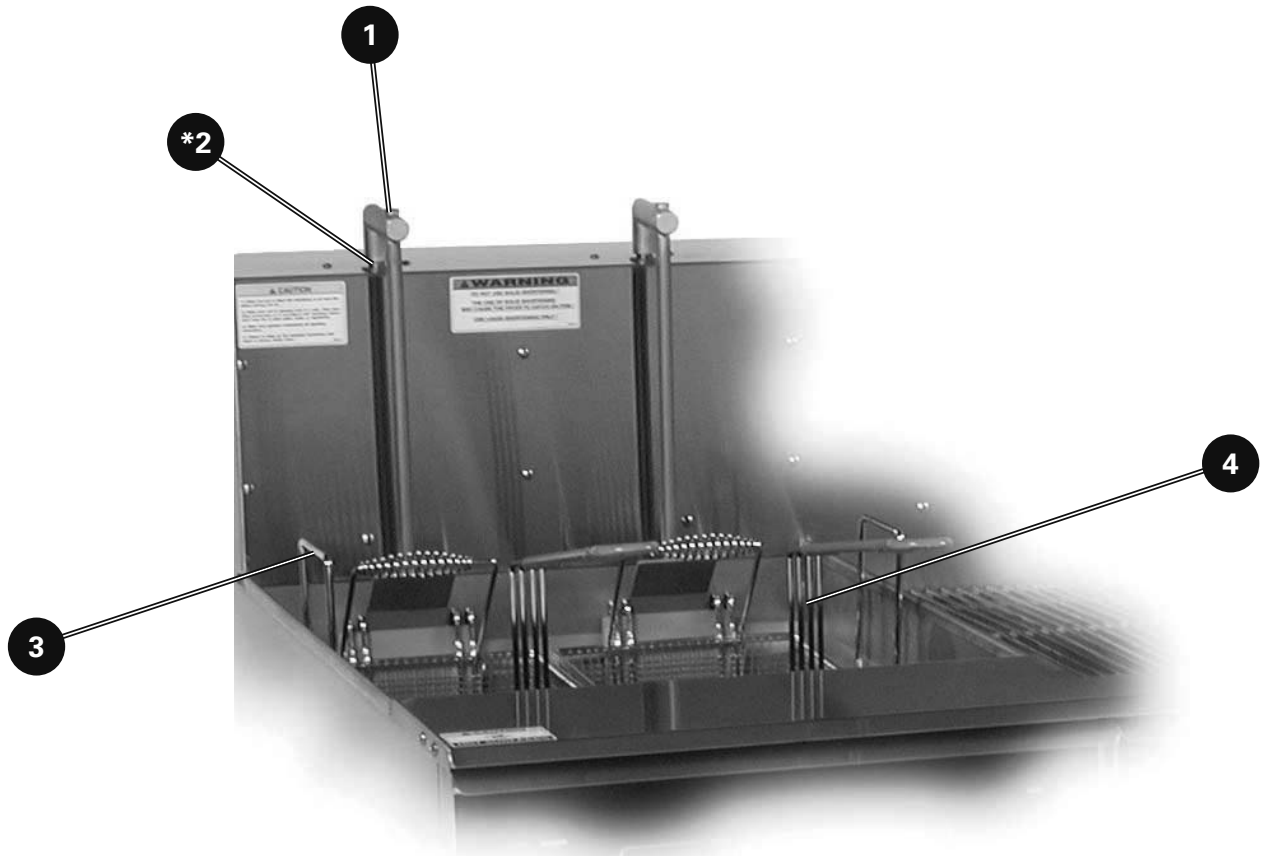



**⚠ CAUTION**

- Always use Oven Mitts when using any of these parts. Parts will become very hot during normal use.

### 3-01. Basket Elevator (Optional) and Baskets

Item	Description	Function
1	Basket Carrier (2)	Used to hold the basket in the correct position when the basket is lifted or lower by the elevator.
2	Elevator (2)	Used to lower and lift the basket from the Fry Pot.
3	Crumb Screen	Used inside the Fry Pot to prevent excess breading or product from contacting the Heating Elements.
4	Basket (2)	Used for cooking product.

3-02. EOF-20 Control Panel





3-02. EOF-20 Control Panel		
Item	Description	Function
1	Power Switch	The Power Switch is used to turn power ON or OFF to the unit.
2	Heat Switch	The Heat Switch is used to turn the power to the elements ON or OFF. Place the Heat Switch in the OFF position when programming the controller or shutting down the unit. Place in the ON position when ready to heat the oil.
3	Controller	The Electronic Controller is used for setting a cooking temperature and cooking times.
4	High-Limit Indicator	The Red High-Limit Indicator Light is illuminated as a result of power being shut off to the fryer's heating elements by the built-in solid-state control circuit as a safeguard against overheating. Should this light come on during operation, refer to the Troubleshooting, Section 7, of this manual. NEVER ATTEMPT TO COOK IF THE HIGH-LIMIT LIGHT IS ON!
5	Heat Indicator Light	The Orange Heat Indicator Light will be on when the Heat Switch is in the ON position and the heating elements are heating the oil. The light will go on and off at various times as the oil temperature is maintained.
6	Power Indicator Light	The Green Power Light is on whenever the fryer's Power Switch is in the ON position.
7	Elevator Switch	The Elevator Switch is used to turn the Elevator power on or off. If the switch is ON the Elevator will lower when a cooking cycle starts and rise when a cooking cycle ends. If the switch is OFF the Elevator will not operate.

3-03. EOF 20 Left Lower Cabinet Area



1

2

3

3-03. EOF-20 Left Lower Cabinet Area

Item	Description	Function
1	Drain Valve Handle	<p>Used to drain the Fry Pot. Always ensure the Handle is closed and locked prior to adding cooking oil or boil out solution. Your fryer will not heat if this Drain Valve Handle is not completely closed and locked.</p> <p><b>⚠ DANGER</b></p> <p><b>ALWAYS ENSURE THE HEAT SWITCH IS IN THE OFF POSITION BEFORE OPENING THIS VALVE. FAILURE TO COMPLY WITH THIS DANGER NOTICE COULD RESULT IN A FIRE, CAUSING DEATH OR SERIOUS INJURY AND/OR EQUIPMENT/PROPERTY DAMAGE AND VOID THE WARRANTY.</b></p> <p><b>⚠ WARNING</b></p> <p><b>NEVER DRAIN OIL FROM MORE THAN ONE FRY POT AT A TIME INTO THE FILTER PAN. THIS WILL CAUSE THE FILTER PAN TO OVERFLOW. ALWAYS REMOVE OIL FROM THE FILTER PAN BEFORE DRAINING ANOTHER FRY POT.</b></p>
2	Pump Oil Return Handle	Used when Filtering to return oil to the Fry Vat.
3	Filter Pan Quick Disconnect	Used to connect filter pan to fryer pump.

3-04. EOF 20 Right Lower Cabinet Area



3-04. EOF-20 Left Lower Cabinet Area

Item	Description	Function
1	Drain Valve Handle	<p>Used to drain the Fry Pot. Always ensure the Handle is closed and locked prior to adding cooking oil or boil out solution. Your fryer will not heat if this Drain Valve Handle is not completely closed and locked.</p> <p><b>⚠ DANGER</b></p> <p><b>ALWAYS ENSURE THE HEAT SWITCH IS IN THE OFF POSITION BEFORE OPENING THIS VALVE. FAILURE TO COMPLY WITH THIS DANGER NOTICE COULD RESULT IN A FIRE, CAUSING DEATH OR SERIOUS INJURY AND/OR EQUIPMENT/PROPERTY DAMAGE AND VOID THE WARRANTY.</b></p> <p><b>⚠ WARNING</b></p> <p><b>NEVER DRAIN OIL FROM MORE THAN ONE FRY POT AT A TIME INTO THE FILTER PAN. THIS WILL CAUSE THE FILTER PAN TO OVERFLOW. ALWAYS REMOVE OIL FROM THE FILTER PAN BEFORE DRAINING ANOTHER FRY POT.</b></p>
2	Pump Oil Return Handle	Used when Filtering to return oil to the Fry Vat.
3	Discharge Hose Quick Disconnect	Used to connect discharge hose to fryer.

3-05. EOF-20 Basket Hanger and Baskets

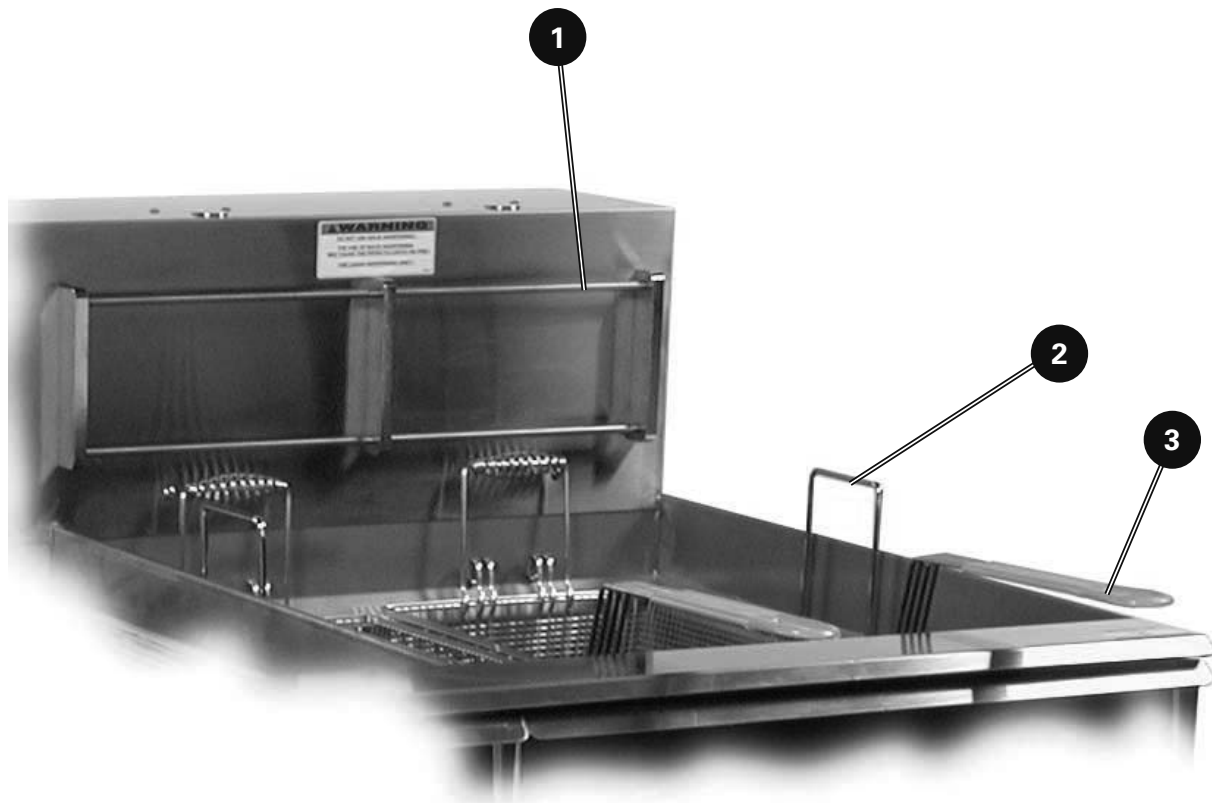



**⚠ CAUTION**

- Always use Oven Mitts when using any of these parts. Parts will become very hot during normal use.

### 3-05. EOF-20 Basket Hanger and Baskets

Item	Description	Function
1	Basket Hanger	Used to hold the basket(s) while excess oil is drained from the product.
2	Crumb Screen	Used inside the Fry Pot to prevent Baskets, excess breading or product from contacting the Heating Elements.
3	Basket (2)	Used for cooking product. (Optional on some units)

3-06. Filter Pan Assembly

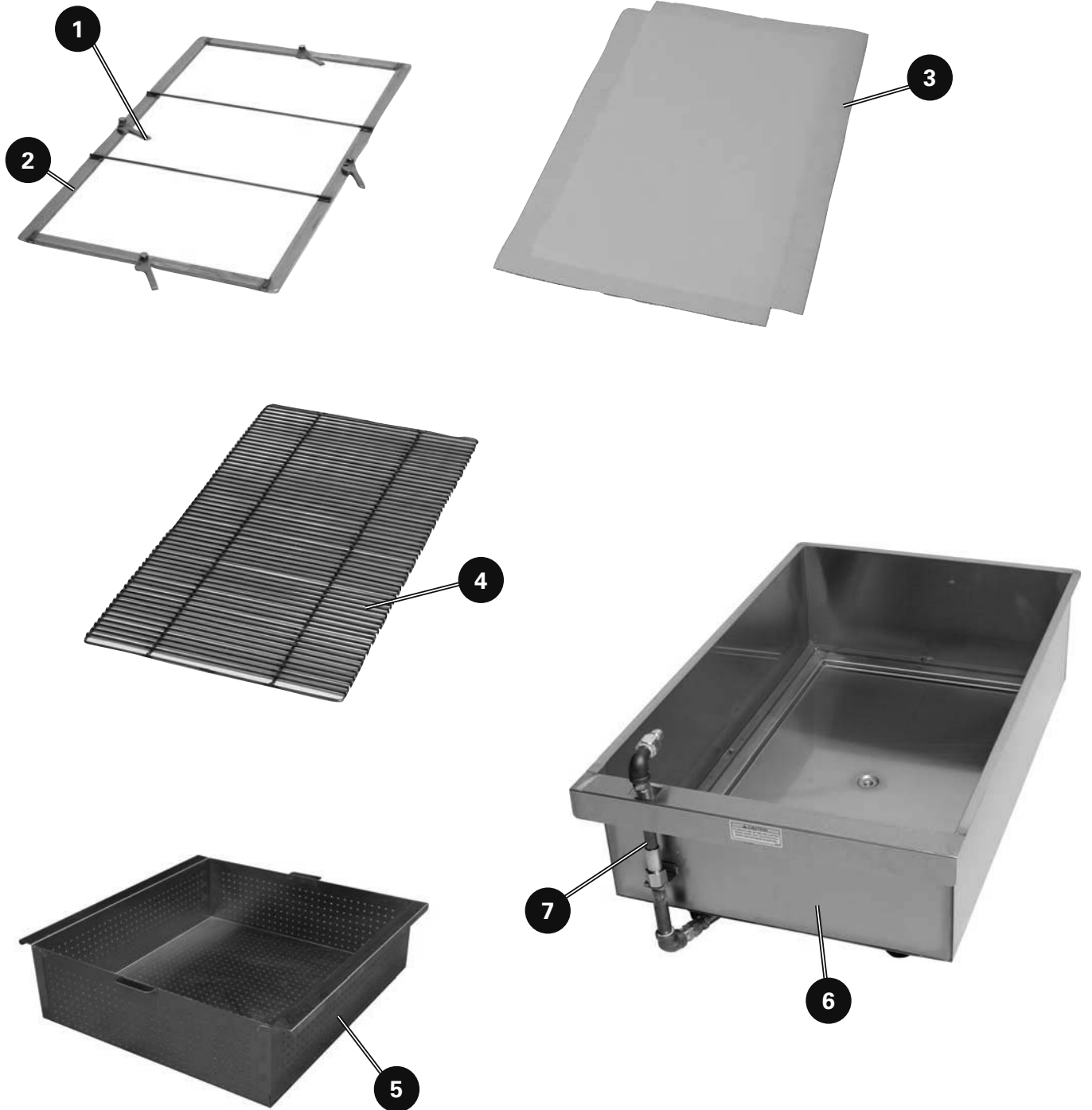





**⚠ WARNING**





- **Never remove the Filter Pan with Liquid Shortening in the pan. This could cause oil to spill. Please see section 5-4. Removal of Liquid Shortening.**



**⚠ CAUTION**



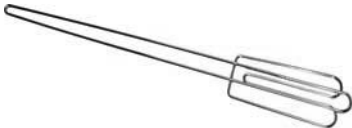

- **Always use Oven Mitts when using any of these parts. Parts will become very hot during normal use.**

### 3-06. Filter Pan Assembly



Item	Description	Function
1	Hold Down Lever (4 Levers)	Used to tightly hold down the hold down frame on the filter paper.
2	Hold Down Frame	Used to tightly hold down the filter paper.
3	Filter Paper (2 Sheets)	Used to filter finer particles of sediment from the cooking oil. The system requires (2) pieces of Filter Paper to be used.
4	Filter Pan Screen	Used to elevate the filter paper from the bottom of the filter pan to allow proper filtration.
5	Filter Pan Crumb Screen	Used to remove larger particles of sediment from the cooking oil during the filtering process.
6	Filter Pan	Used to filter cooking oil. The Filter Pan is removable for cleaning and for the changing of the filter paper.
7	Filter Pan Quick Disconnect Hose	Used to connect to the fryer's oil filtration system. The hose must be disconnected before removing the filter pan.

3-07. Accessories (Included)		
Part	Description/Part Number	Function
	Kettle Drain Brush P/N: 71025	Used for cleaning the Fry Pot.
	Drain Brush, Small P/N: 73235	Used for cleaning the FFLT drain
	Stir Paddle P/N: 77775	Used for stirring Hot Oil and Product being cooked.
	Fry Vat Clean Brush P/N: 71100	Used for cleaning Fry Pot and Elements.
	Crumb Shovel P/N: 30059	Used for removing sediment from the Filter Pan.

3-07. Accessories (Included)		
Part	Description/Part Number	Function
	<p>L Shaped Brush P/N: 73233</p>	<p>Used for cleaning between elements.</p>
	<p>Vat Drain Clean Out P/N: 36577</p>	<p>Used to clear excessive sediment build up from the Vat Drain.</p>
	<p>Wand Hose P/N: 33667</p>	<p>Used for removing liquid shortening from unit.  Note: Not recommended for washing down the fry pot.</p>

3-07. Accessories (Included)		
Part	Description/Part Number	Function
	(1) EOF-20 Fry Basket (Blue Handle) P/N: 70420	Used for cooking product in the EOF-10-10 or the EOF-20.
	(1) EOF-20 Fry Basket (Yellow Handle) P/N: 71109	Used for cooking product in the EOF-10-10 or the EOF-20.
	(2) EOF-20 Fry Screen P/N: 70083	Used to prevent excess breading or product from contacting the Heating Elements.
	Product Scoop P/N: 70430	Used for removing cooked product when Fry Baskets are not used. (Optional on some units)

**3-08. Accessories (Not Included)**

Part	Description/Part Number	Function
	<p>Filter Paper P/N:60709</p>	<p>Used to filter the cooking oil.</p>
	<p>Filter Powder P/N: 72004</p>	<p>Used to help clean the cooking oil.</p>
	<p>Fryer Boil-Out P/N: 72003</p>	<p>Used to help clean the fry pot.</p>

3-08. Accessories (Not Included)		
Part	Description/Part Number	Function
	<p>Giles Oil Caddy P/N: 79187</p>	<p>A portable oil disposal container with a capacity of 80lbs of liquid shortening.</p> <p>Note: For use with filtered, warm oil only. No crumbs or debris.</p>

## 4. Unit Preparation

We at Giles Enterprises, Inc. take pride in the quality of our workmanship. Every effort has been made to ensure that your unit is in good operating condition when you receive it. Each unit must pass a rigorous quality control test prior to shipment. To further ensure optimum operation of your new unit, a brief operational check-out of your new fryer must be conducted as set-out in this section.

### **CAUTION**

- Before attempting to operate the unit, refer to Section 3 to familiarize yourself with the various control functions. Once you have read and fully understand Section 3, please follow the steps below precisely in order to prevent equipment damage or malfunction.

### 4-01. Settings before each test

Please ensure each unit's control panel and valves are set to the following before proceeding to each test.

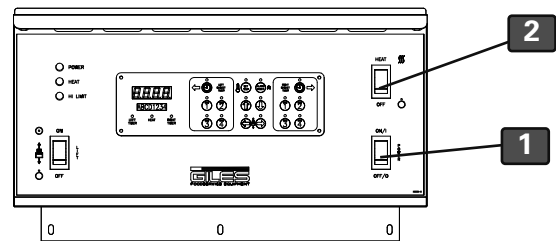

EOF-20

1. Power Switch is in the OFF **1** position.
2. Heat Switch is in the OFF **2** position.

4-01. Settings before each test (Continued from previous page)

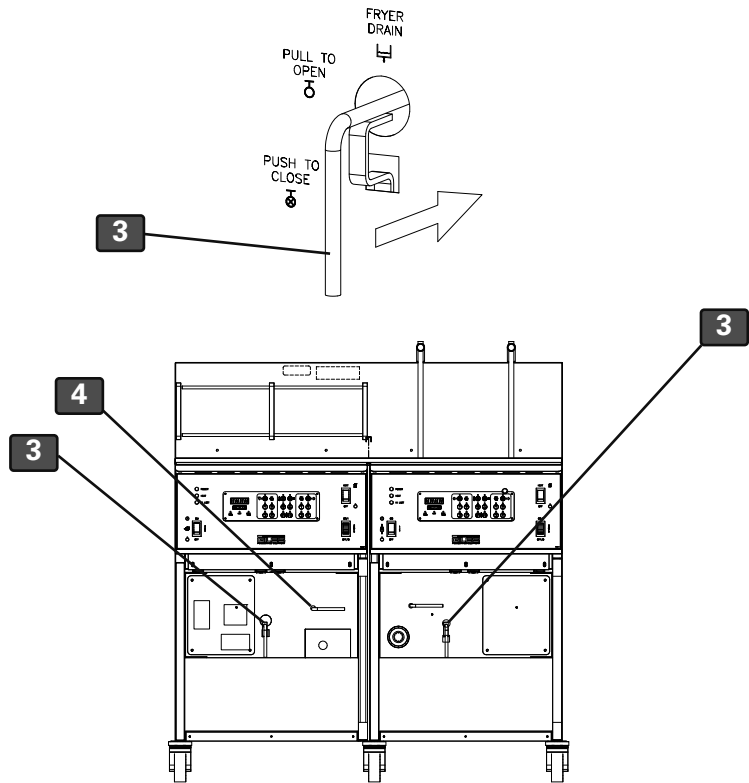

3. Open the Left EOF-20 Cabinet Door and remove the Filter Pan.
4. Ensure the Drain Valve Handle on each unit is in the CLOSED and Locked **3** position.
5. Ensure the Oil Diverter Valve is in the TO FRYER **4** position.
6. Remove Crumb Screen(s) and Baskets.

EOF-20/20



## 4-02. Power test

The following test will ensure the unit has power. Perform this test on each unit.

1. Follow steps shown in Section 4-1.
2. Ensure the main circuit breaker powering the unit is ON. If a Quick Disconnect Box is used, ensure it is ON.
3. Press the Power Switch to the ON **1** position. The green POWER light **2** will come on. Please proceed to Section 4-3.

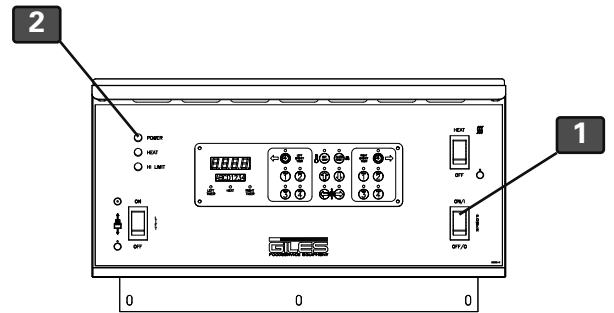

EOF-20

If the POWER light does not come on, refer to the Troubleshooting procedure in Section 7-1.

4-03. Heating Element test

The following test will ensure the Heating Element is being powered. Perform this test on each Fry Pot.

**⚠ DANGER**

•DO NOT touch the Heating Elements. The Heating Elements are very hot and skin contact with the Heating Elements may result in severe burns.

1. Follow steps shown in Section 4-1.
2. Ensure Power Switch is in the OFF position.
3. Wipe the Heating Element **1** with a sponge wet with water.
4. Press the Power Switch to the ON **2** position.
5. Wait until the display **3** reads "HOLD."
6. Press the Set Temp **4** button, the Display should read 350. If it does not set the temperature to 350, see Section 5-1.2. Programming the Cooking Temperature.
7. Press the Heat Switch to the HEAT **7** position. Leave in the HEAT position **NO MORE THAN 10 SECONDS.**  
 Note: If the Scroll Display **8** reads "Check Oil Level," press the Power Switch to the OFF **9** position, then proceed to the next step.

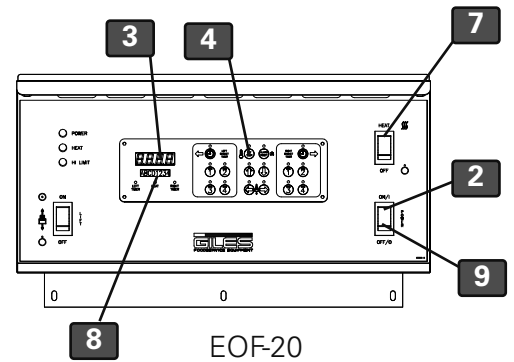
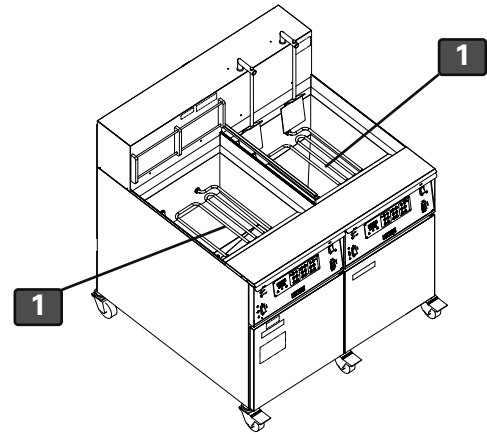

Continued next page

## 4-03. Heating Element test (Continued from previous page)

8. Press the Heat Switch to the OFF **10** position
9. The wet element should quickly dry within 15 seconds. Proceed to Section 4-4.

If the Heating Element does not dry within 15-30 seconds, refer to the Troubleshooting procedure in Section 7-1.

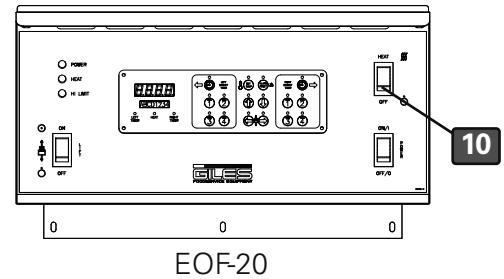

## 4-04. Filter Pump Test

The following test will ensure the Filter Pump is operating correctly.

1. Follow steps shown in Section 4-1.
2. Open Cabinet Door.
3. Place the palm of your hand over the Quick Disconnect **1** for the Filter Pan Hose.
4. Briefly press the Pump Switch to the PUMP **2** position then press the Pump Switch to the OFF **3** position. If suction is felt on the palm, the pump is operating correctly. Proceed to Section 4.5.

If no suction is felt, refer to the Troubleshooting procedure in Section 7-2.

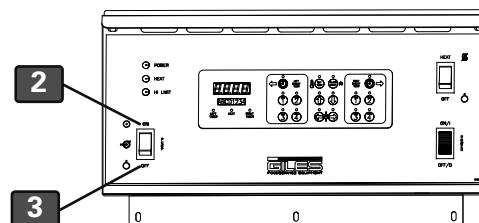
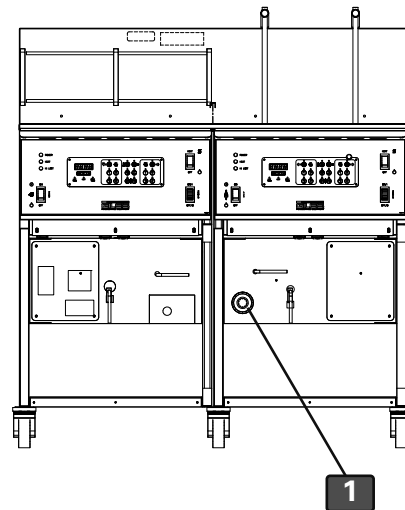

**4-05. Perform Boil Out Procedure**

Perform a Boil Out Procedure to remove any particles or debris that may have been left due to shipping. Follow Section 6-1 Boil Out Procedure. After performing the Boil Out Procedure proceed to Section 4-6.

**4-06. Clean Filter Pan**

Thoroughly clean the Filter Pan to remove any particles or debris that may have been left due to shipping. Follow Section 6-2 Cleaning the Filter Pan and replacing Filter Paper after Boil Out.

The fryer's preparation is now complete. Please proceed to the Fryer Operation Section.

## 5. Fryer Operation

This section describes how to operate the unit.

### DANGER

- Turn off the unit and turn off the fryer's circuit breaker in the main circuit breaker box before cleaning or performing maintenance.
- DO NOT hose down the unit's interior or exterior with water.
- Failure to comply with these DANGER notices will result in death or serious injury, equipment/property damage, and void the warranty.

### CAUTION

- Ensure the unit is positioned in a secure, safe location with the casters in the locked position.
- Consult an electrician to ensure all electrical specifications have been met and the unit is properly grounded. The wiring diagrams contained in this manual should aid your electrician in the installation of your fryer.
- Due to the high temperature of cooking oil in your fryer during cooking, it is extremely important the user exercise caution in operation this equipment to avoid personal injury.

5-01. Cooking Controller

The following section describes the functions, features and programming of the Cooking Controller.

EOF-20

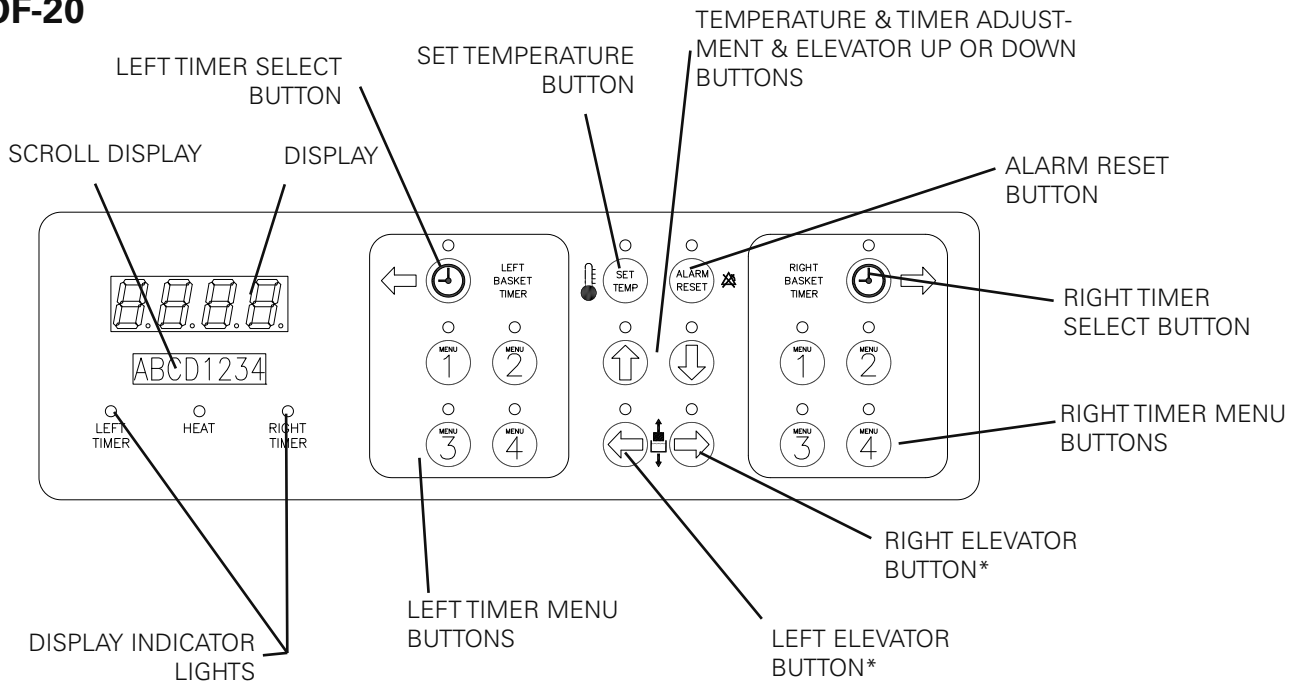

\* -Basket Elevator Option Only

## 5-01.1. Buttons and Functions

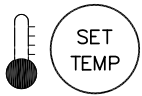

Used to set and display cooking temperature.

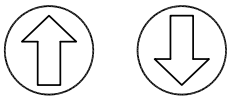

Used to increase or decrease cooking time and temperature.

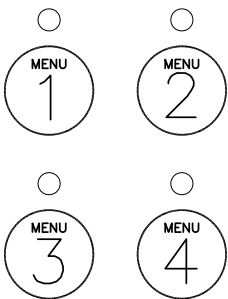

Used to set and recall cooking times.



Used to silence alarm.

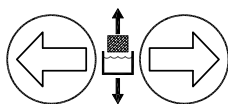

**EOF-20:** Used to select Left or Right Basket Elevator. (Basket Elevator Option Only)

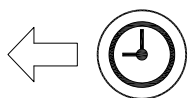

Used to select the Left Basket Timer.

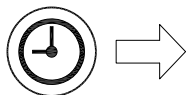

Used to select the Right Basket Timer.

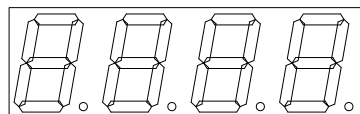

Used to display cooking times and temperature.



Scrolls various status information.

5-01.2. Programming the Cooking Temperature

EOF-20

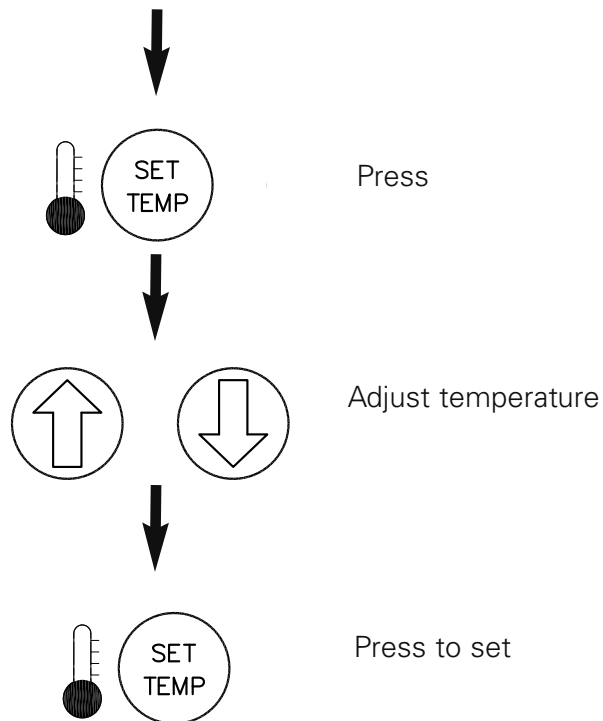
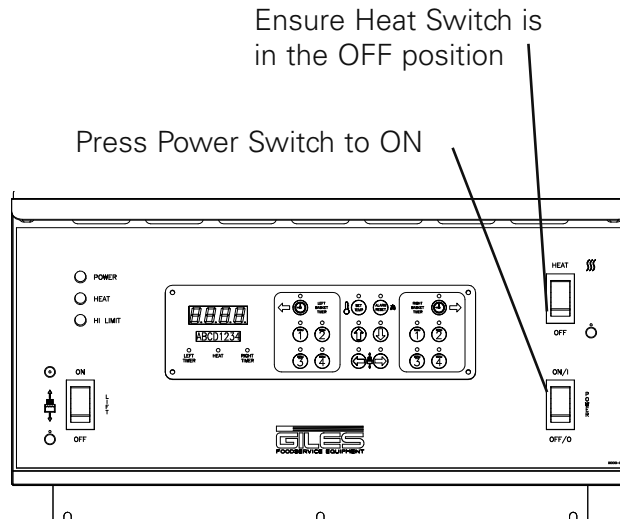



## 5-01.3. Programming a Cooking Time

### EOF-20

Ensure Heat Switch is in the OFF position

Press Power Switch to ON

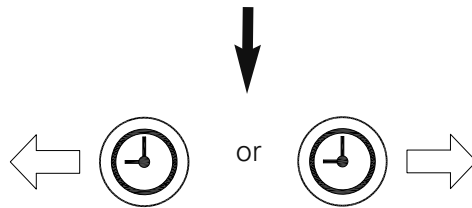
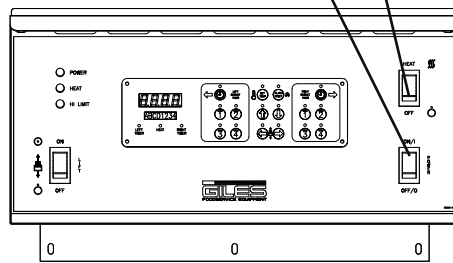

Press and hold both the desired Basket Timer (left or right) and the desired Menu Key for 5 seconds

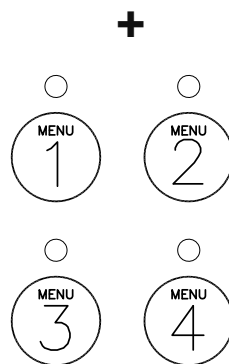

5-01.4. Start a cooking time

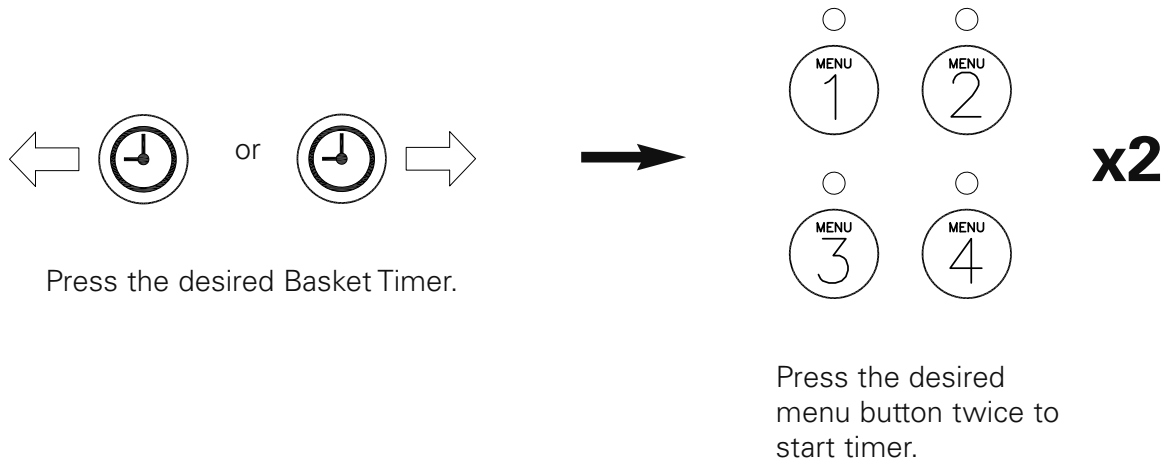

5-01.5. Cancel the currently running cooking time



(Basket Elevator Option Only) If cancelled and the Basket Elevator has been lowered, the Basket Elevator will raise when cancelled.

5-01.6. Manually lowering and raising the cooking basket (Basket Elevator Only)

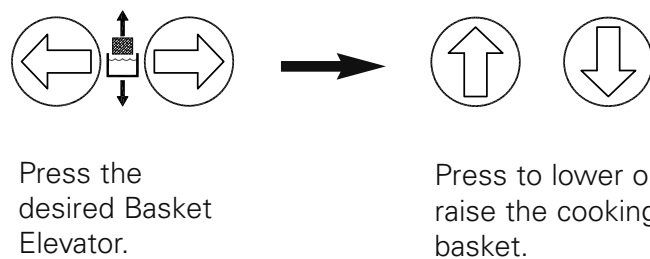

## 5-01.7. Displaying remaining cooking time

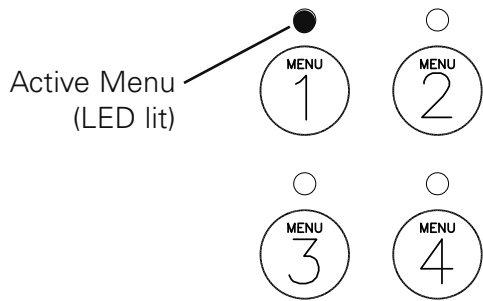

Press the active (LED lit) Timer Menu button



● LEFT  
TIMER

○ HEAT

○ RIGHT  
TIMER

The time is displayed and the Left or Right LED is lit to identify the Basket time being displayed.

## 5-01.8. Displaying the actual temperature of the liquid shortening

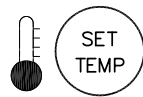

Press and Hold for 5 seconds

=



Actual temperature will display for 20 seconds

5-02. Cooking Procedure

This section describes the cooking process for the unit.

1. Program the Controller to the desired temperature, See Section 5-1.2.
2. Ensure the Power Switch is in the OFF **1** position.
3. Ensure the Heat Switch is in the OFF **2** position.
4. Ensure the Drain Valve is pushed in and locked in the CLOSED **3** position.
5. Fill the Fry Pot with liquid shortening to only the ADD **4** level. The Fry Pot is filled only to this level due to the expansion of liquid shortening which occurs after it is heated.

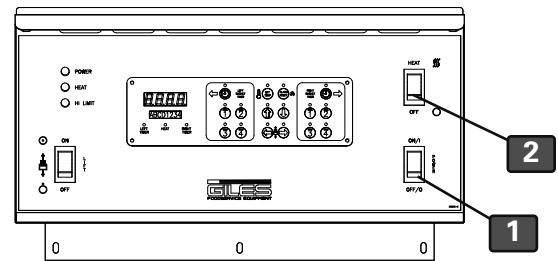

EOF-20

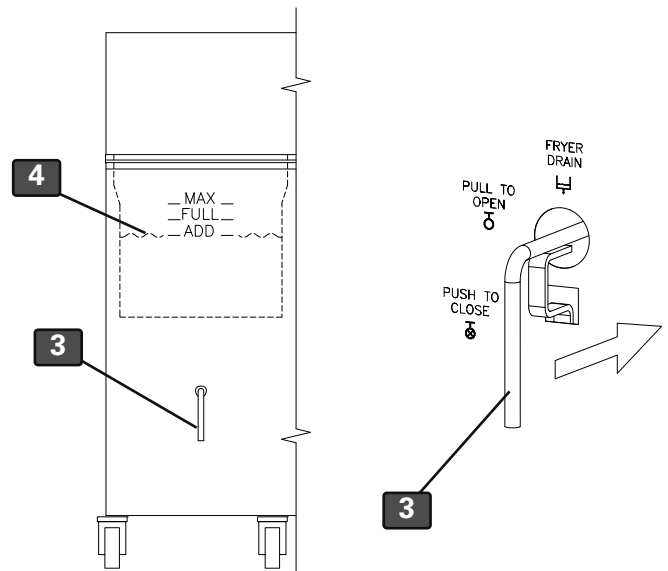

Continued next page

## 5-02. Cooking Procedure (Continued from previous page)

6. Press the Power Switch to the ON **5** position. The Power Light **6** will come on. If the unit is equipped with the Basket Elevator Option, and you want to engage this option, press the Basket Elevator Switch to the ON **7** position.

**NOTE:**

- If when pressing the Power Switch to the ON position, an alarm sounds and the Scroll Display reads "Drain Open -Close and Push Reset"; follow step 4, above, then press Alarm Reset on the Cooking Controller.

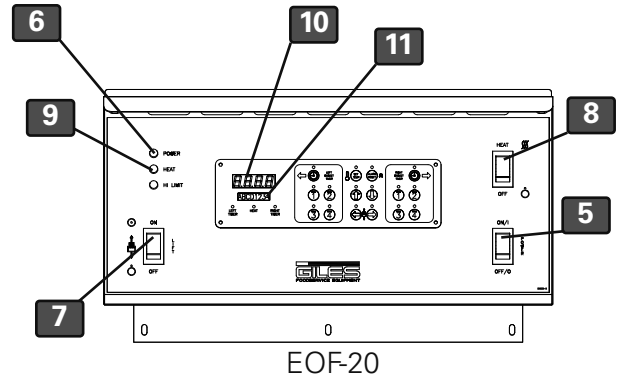

7. Press the HEAT Switch to the ON **8** position. The Heat Light **9** will come on, the display will read "HOLD" **10** and the Scroll Display will read "Oil Heating" **11**. The Oil will begin to heat to the programmed temperature .

5-02. Cooking Procedure (Continued from previous page)

**NOTE:**

- The following step will help remove any cold area in the Liquid Shortening which will allow the product to be cooked more evenly.

8. Once the oil has reached it's first preheat, an alarm will sound and the Scroll Display will read "Stir Oil and Push Reset" **11**. Using the supplied Stir Paddle, thoroughly stir the Cooking Oil, then press the Alarm Reset **12** button.

9. When the Heat Light **13** goes out the Oil is heated to the set point.

10. Check the Liquid Shortening level, it should now be at the FULL Level **14**. Add Liquid Shortening if needed.

11. Place the Crumb Screen **15** in Fry Pot.

12. (Basket Elevator Option Only) Place the Cooking Basket **16** on the Basket Carrier **17**.

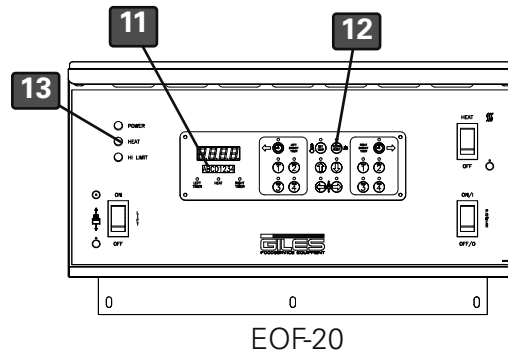

EOF-20

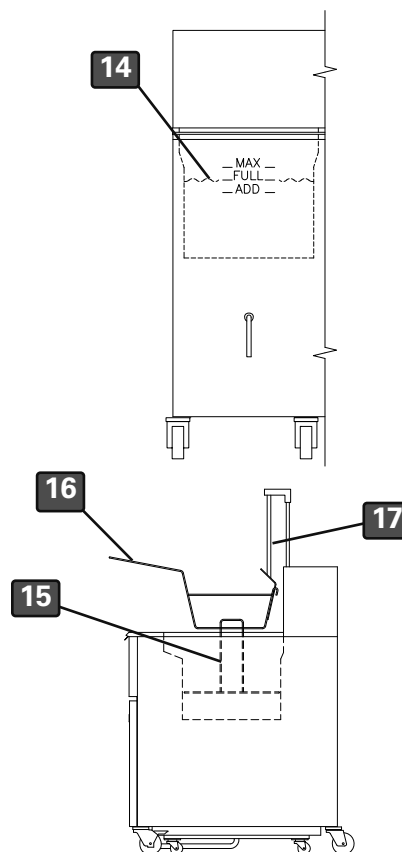

Continued next page

## 5-02. Cooking Procedure (Continued from previous page)

13. We recommend placing uncooked product into the Cooking Basket with the basket in the up position, then lowering the basket into the oil. However, uncooked product may be placed into the Cooking Basket after the Cooking Basket has been lowered.

**CAUTION**

- Use extreme caution when placing product in the HOT liquid shortening, as the HOT liquid shortening could cause severe burns.

14. (Basket Elevator Option Only) Press the desired Basket Lift Button **18**. Then press the Down Arrow **19**. Cooking Basket will lower.

(Basket Hanger Option Only) Place Baskets in Fry Pot on top of Crumb Screen **20**.

15. Press desired Basket Timer **21** Button , then press the desired Menu Time **22** Button two times. The the time will start counting down and the Scroll Display will read "Cooking" **23**.

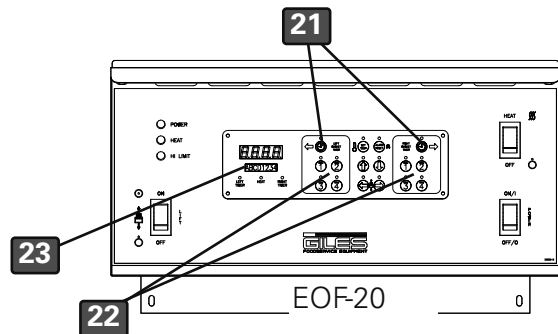
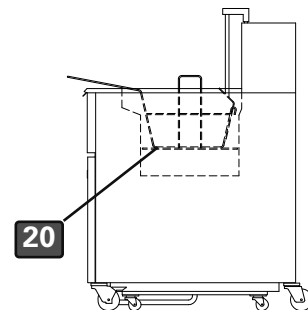
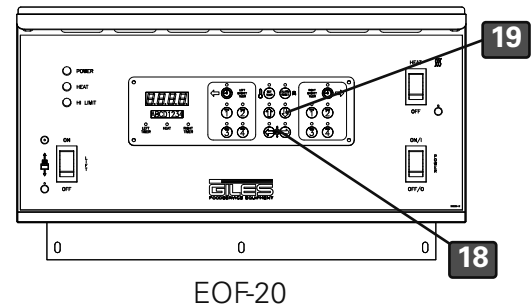

**5-02. Cooking Procedure (Continued from previous page)**

16. After 60% of the cooking time has elapsed from the selected cooking time, the stir cycle alarm will sound and the Scroll Display will read "Stir Product" **24**. Using the Stir Paddle **25** and wearing Oven Mitts stir the product, then press the Alarm Reset Button **26**.

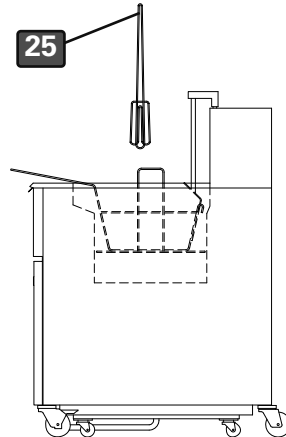

17. (Basket Elevator Option) At the end of the cooking time an alarm will sound and the Display will read "DONE" **27**. The Scroll Display will read "Left Timer" or "Right Timer" **24**. The Cooking Basket **28** and the cooked product will automatically raise from the Hot Liquid Shortening. Press the Alarm Reset **26** Button to silence the alarm.

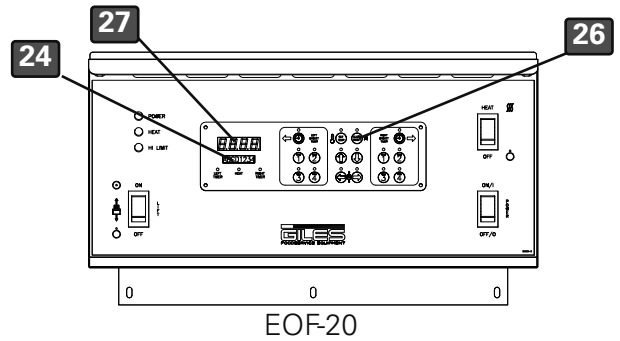

(Basket Hanger) At the end of the cooking time an alarm will sound and the Scroll Display will read "DONE" **27**. The Scroll Display will read "Left Timer" or "Right Timer" **24**. Using Oven Mitts lift the Basket **28** from the cooking oil and hang the Basket on the top bar of the Basket Hanger **29**. Press the Alarm Reset **26** Button to silence the alarm.

- 18. Allow the cooked product to adequately drain.
- 19. Using Oven Mitts remove the Basket and place cooked product on a landing table or in an appropriate container.
- 20. • To continue cooking on the unit return to step 6 of this procedure.
- To shut down the unit, see Section 5-5 Normal Shut-Down.

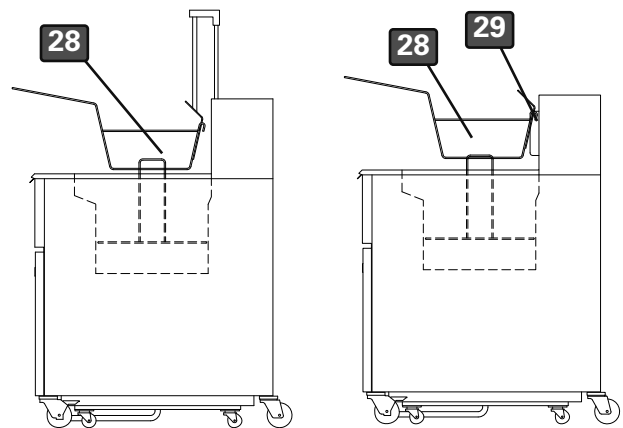

Basket Elevator

Basket Hanger



## 5-03. Filtering Liquid Shortening

This section describes how to filter Liquid Shortening through the built-in filtration system. The filtration system recirculates the Liquid Shortening through the Filter Pan, Filter Paper and Cooking Vat. By following this process you will increase the Liquid Shortening life up to 50%. The Cooking Controller is preset to alert you to filter every fourth load.

### CAUTION

- **Never try to filter cold Liquid Shortening, this could clog the filter pump and damage the unit. Liquid Shortening must be heated to a minimum of 200°F (93°C) before filtering.**

1. After cooking the fourth load in the Fry Pot the oil will need to be filtered.
2. On the unit to be filtered, press the Heat Switch to the OFF **1** position.
3. Open the Cabinet Door. Wearing Oven Mitts, disconnect the Filter Pan Quick Disconnect Hose **2** then remove the Filter Pan **3** from the unit.
4. Ensure the Filter Pan has (2) sheets of Filter Paper installed correctly.
5. Add one package (4.8 ounces) of Giles Filter Powder (Part No. 72004) into the Filter Pan.
6. Ensure the Filter Pan Cover is in place, then reposition the Filter Pan in the unit and reconnect the Filter Pan Quick Disconnect Hose **2**.

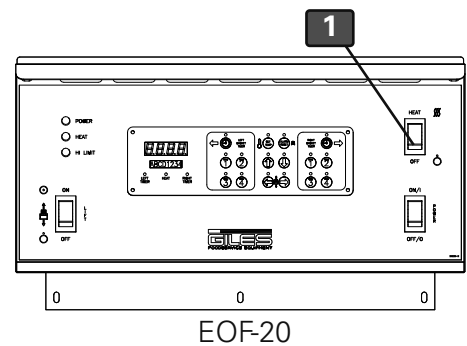

### DANGER

- **In the next step Liquid Shortening is drained into the Filter Pan. Failure to ensure the fryer's Heat Switch is in the OFF position prior to draining may result in fire from the exposed Heating Elements. ALWAYS ENSURE THE HEAT SWITCH IS IN THE OFF POSITION BEFORE DRAINING LIQUID SHORTENING.**

### WARNING

- **Never drain both sides into the Filter Pan! The Filter Pan only has capacity for one Fry Pot.**
- **Never disconnect the Filter Pan from unit with Liquid Shortening in the Filter Pan.**

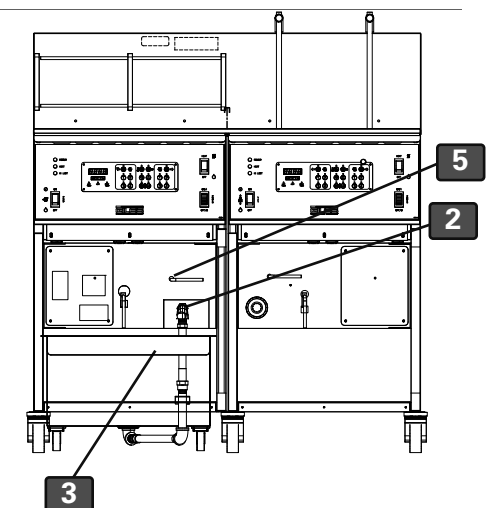

Continued next page

5-03. Filtering Liquid Shortening (Continued from previous page)

7. On the unit to be filtered, ensure the Heat Switch is in the OFF **1** position. On the Right EOF-20, ensure the Oil Diverter Valve is in the TO FRYPOT **5** position. On the unit to be filtered, slowly unlock and pull the Drain Valve Handle to the OPEN **6** position. This will allow Liquid Shortening to drain into the Filter Pan.

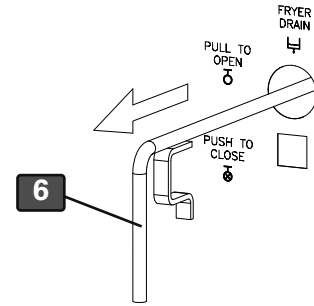

**NOTE:**

- If the Fry Pot does not drain use the supplied Kettle Drain Brush to break up the crumbs in the Fry Pot Drain.

**CAUTION**

- Be careful not to puncture the filter paper in the filter pan. This could cause the filter pump to clog and damage the unit.

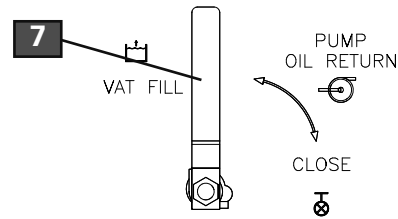

8. Turn the Pump Oil Return Handle on the unit to be filtered to the VAT FILL **7** position.

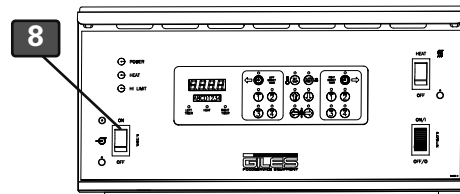

9. Once the Fry Pot has completely drained into the Filter Pan, press the Pump Switch to the ON **8** position.

10. The Liquid Shortening will begin to recirculate **9** through the Filter Pan and back to the Fry Pot. Leave the Drain Valve open and allow the Liquid Shortening to continually circulate for a minimum of 5 minutes.

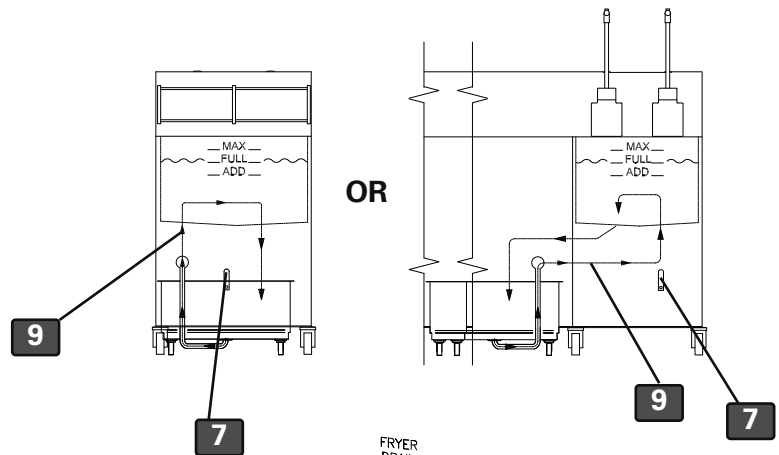

11. Allowing the Liquid Shortening to recirculate for a minimum of 5 minutes, then push in and lock the Drain Valve Handle to the CLOSE **10** position and allow the Fry Pot to refill.

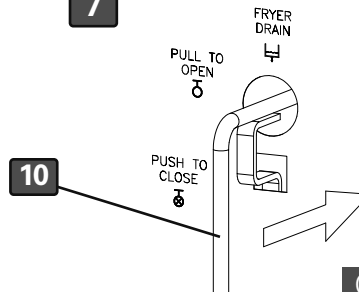

Continued next page

## 5-03. Filtering Liquid Shortening (Continued from previous page)

12. After the Fry Pot has refilled, press the Pump Switch to the OFF **11** position.
13. Turn the Pump Oil Return on the unit being filtered to the CLOSE **12** position.
14. Ensure the Fry Pot contains the proper level of Liquid Shortening, add if needed.
15. • To continue cooking, See Section 5-2, Cooking Procedure.  
  
• To discontinue cooking, See Section 5-5, Normal Shut Down.

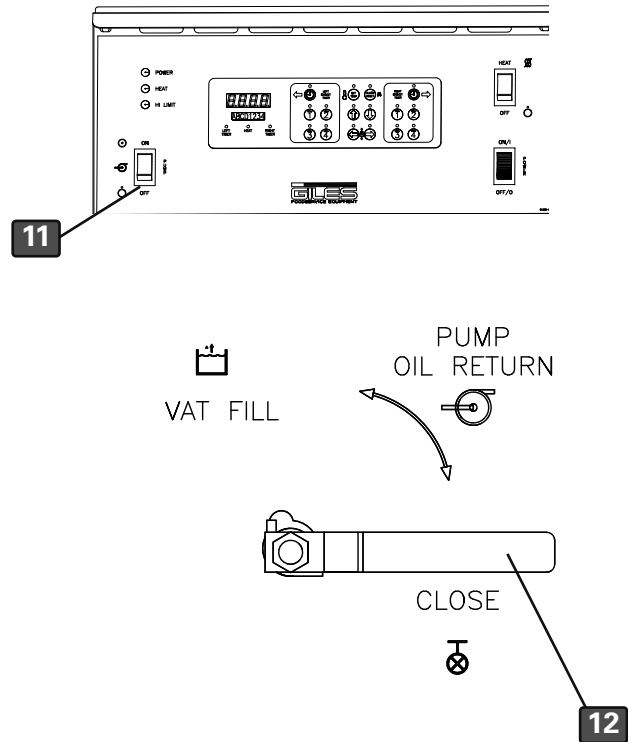

**5-04. Removal of Liquid Shortening**

This section describes how to remove Liquid Shortening from the unit. Liquid Shortening must be removed from the fryer before a Boil Out is performed. In this section a Giles Oil Caddy (not included) is used to dispose the used Liquid Shortening.

**CAUTION**

- **Never try to remove cold Liquid Shortening using this procedure, this could clog the filter pump and damage the unit. Liquid Shortening must be heated to a minimum of 200°F (93°C) before following this procedure.**

1. If the Liquid Shortening is cold, heat to 200°F (93°C).
2. Ensure the Power Switch is in the ON **1** position.
3. Next, ensure the Heat Switch is in the OFF **2** position.
4. Ensure the Filter Pan **3** and the Filter Pan Cover are in place. Ensure the quick disconnect hose **4** is connected the to unit. Ensure the Pump Discharge Handle is in the TO FRYER **5** position.

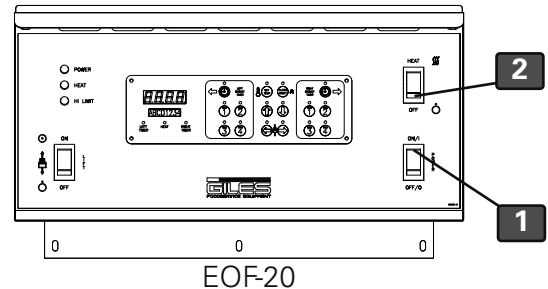

**DANGER**

- **In the next step, Liquid Shortening is drained into the Filter Pan. Failure to ensure the fryer's Heat Switch is in the OFF position prior to draining may result in fire from the exposed Heating Elements. ALWAYS ENSURE THE HEAT SWITCH IS IN THE OFF POSITION BEFORE DRAINING LIQUID SHORTENING.**

**WARNING**

- **Never drain more than one Fry Pot into the Filter Pan! The Filter Pan only has capacity for one Fry Pot.**
- **Never disconnect the Filter Pan from unit with Liquid Shortening in the Filter Pan.**

5. Slowly unlock and pull the Drain Valve Handle to the OPEN **7** position and allow the Fry Pot to completely drain into the Filter Pan.

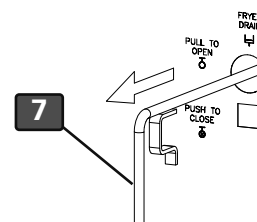
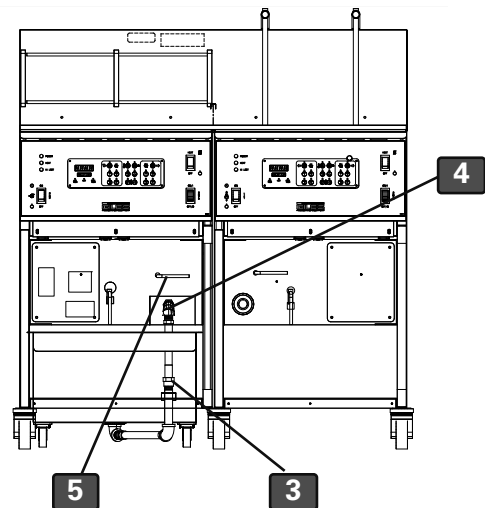

Continued next page

## 5-04. Removal of Liquid Shortening (Continued from previous page)

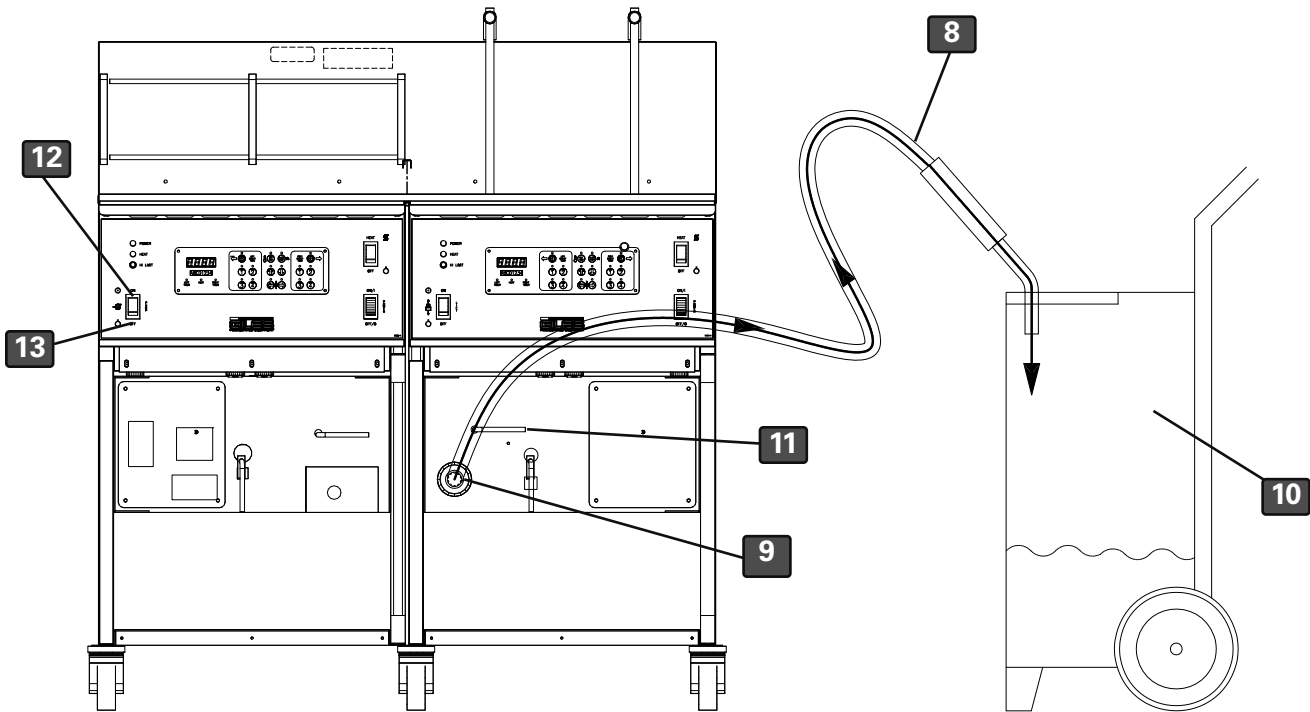

6. Connect the Discharge Hose **8** to the Discharge Hose Coupling **9**.
7. Place the discharge end into a Hot Oil Disposal Container **10** (Giles Oil Caddy shown).
8. Turn the Oil Diverter Valve to the TO DISCHARGE HOSE **11** position.

### **⚠ WARNING**

- **During the next step be sure to wear Oven Mitts if holding the Discharge Hose, as the hose will become very hot.**

9. Press the Pump Switch to the PUMP **12** position and allow the liquid shortening to pump into the Disposal Container.
10. After the Liquid Shortening is removed from the Filter Pan, press the Pump Switch to the OFF **13** position.

5-04. Removal of Liquid Shortening (Continued from previous page)

11. Press the Power Switch to the OFF **14** position.
12. Push and lock the Drain Valve to the CLOSED **15** position.
13. Turn the Oil Diverter Valve handle to the TO FRY-POT **16** position.

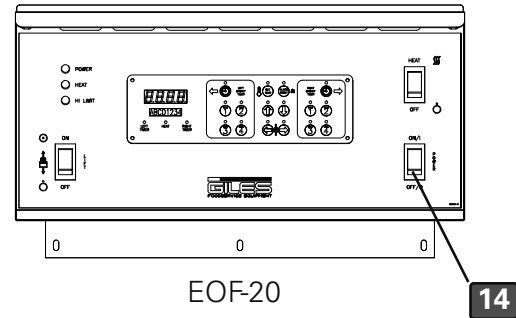

**WARNING**

- During the next step be sure the wear Oven Mitts as the Discharge Hose and the Discharge Hose Coupling will become very hot.

14. Remove the Discharge Hose from the Discharge Hose Coupling and drain the excess Liquid Shortening remaining in the hose into the Oil Disposal Container.
15. Allow the Filter Pan to thoroughly cool, then remove and thoroughly clean the Filter Pan and the Filter Pan Cover.
16. • To perform a Boil Out on the unit see Section 6-1 Boil Out Procedure.  
• To shut down the unit see Section 5-5 Normal Shut-Down.

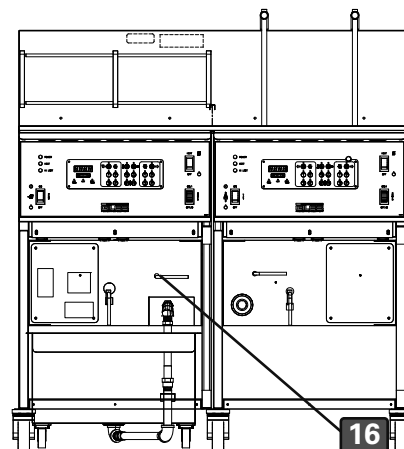
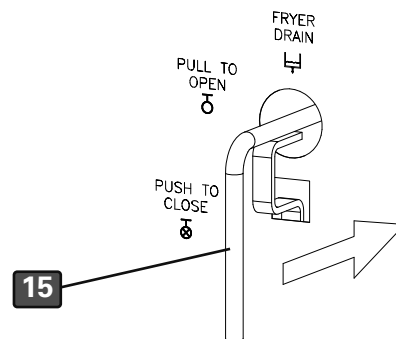

## 5-05. Normal Shut-Down

This section explains the process of shutting the unit down.

1. Press the Heat Switch to the OFF **1** position.
2. Press the Power Switch to the OFF **2** position, the Power Light **3** will go off.
3. If required, turn off the fryer circuit breaker in the main circuit breaker box to remove power to the unit.

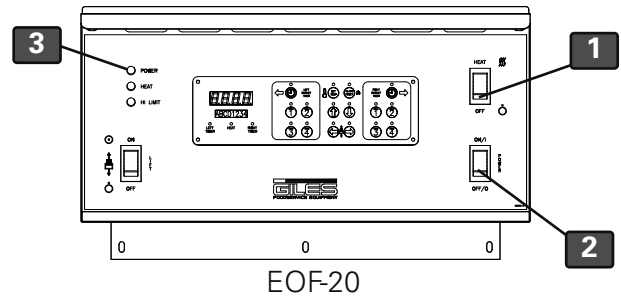

## 5-06. Emergency Shut-Down

In case of emergency, remove power to the unit by turning off the facility circuit breaker.



**Notes:**



## 6. Cleaning

This section describes the cleaning operations for the EOF-20/20. The unit should be cleaned on a daily basis.

### **⚠ DANGER**

- **DO NOT hose down the unit's interior or exterior with water.**
- **Failure to comply with these DANGER notices will result in death or serious injury, equipment/property damage, and void the warranty.**

### 6-01. Boil-Out Procedure (Cleaning the Fry Pot)

This section describes how to clean the Fry Pot in the unit. This process is referred to as "Boil-Out". A "Boil-Out" must be performed before cooking with new equipment and should be performed each time liquid shortening is discarded from the unit.

For proper operation of the fryer, the Boil-Out procedure should be carried out every 7 to 14 days.

### **⚠ DANGER**

- **DO NOT under any circumstances leave the fryer unattended during this procedure as heat must be carefully monitored to prevent the Fry Pot from overflow due to boiling. Overflow of the Fry Pot may result in serious equipment damage.**

1. Remove Liquid Shortening from the unit, see Section 5-4. Removal of Liquid Shortening.
2. Ensure the Drain Valve Handle is pushed in and locked in the CLOSED **1** position and the Power Switch is in the OFF **6** position.
3. Fill the Fry Pot with water to the FULL level **2**.
4. Following the directions on the Giles Boil-Out Container, add the recommend amount of Boil-Out to the Fry Pot.

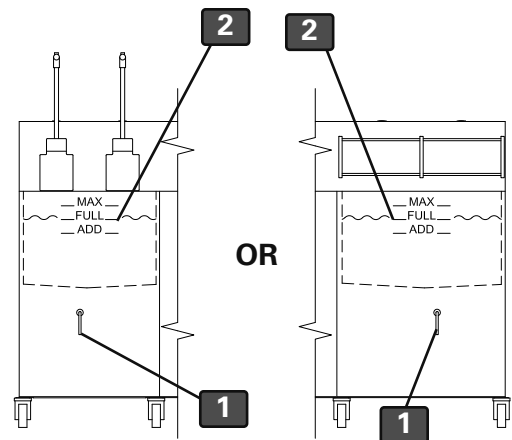

### **⚠ CAUTION**

- **If using a cleaner other than Giles Boil-Out pay close attention to the instructions listed on the container. Many commercially available cleaners are caustic chemicals which require special precautions. If used improperly, these chemicals may cause damage to the fryer and potential injury to the user.**

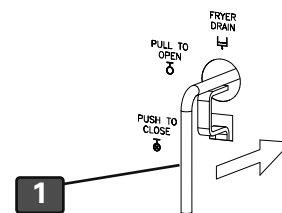

Continued next page

6-01. Boil Out Procedure (Continued)

5. Press the Power Switch to the ON **3** position.
6. Set the Cooking Temperature to 200°F (93°C) See Section 5-1.2.
7. Press the Heat Switch to the HEAT **4** position.
8. The Boil Out Solution will heat to 200°F (93°C). See directions on Boil Out container for suggested cycle time.

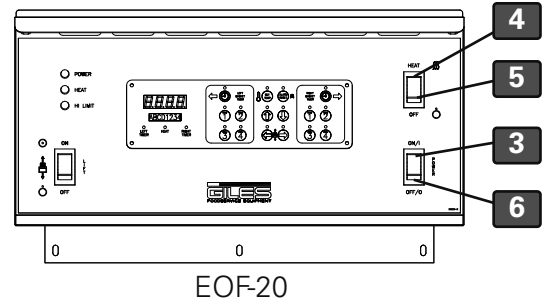

If desired, set a cooking time to a Basket Timer for the suggest Boil Out time, See Section 5-1.3.

9. At the completion of the Boil Out Cycle time press the Heat Switch to the OFF **5** position and the Power Switch to the OFF **6** position.
10. Disconnect Quick Disconnect Hose, remove the Filter Pan, then remove the Filter Pan Cover.

**CAUTION**

- In the next step **DO NOT drain the Boil-Out into the Filter Pan! Contents are corrosive and will cause damage to the Filter Pan, the Hold-Down Frame, and the Filter Pump. Failure to comply may result in minor or moderate injury, equipment/property damage, and void the warranty.**
- In the next step always ensure the container which is used is heat resistant up to 300°F (148°C). Plastic is generally not safe as it may melt or break. Metal containers which do not leak are preferable to containers made of other materials. Failure to comply with this caution may result in serious injury.

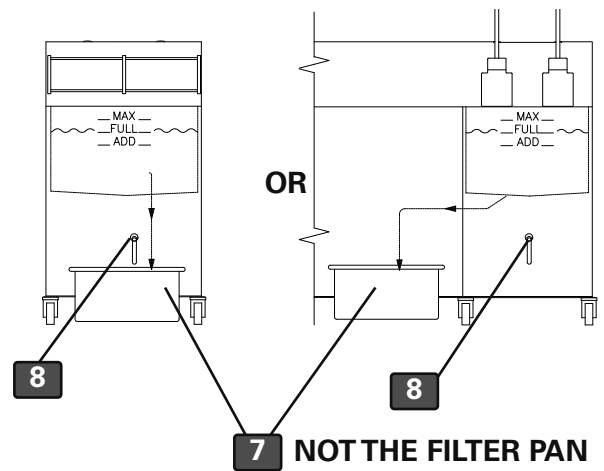

11. Position a suitable **Heat Resistant Container 7** (not supplied with the unit) beneath the Fryer Drain.
12. Slowly unlock and pull the Drain Valve Handle to the OPEN **8** position.

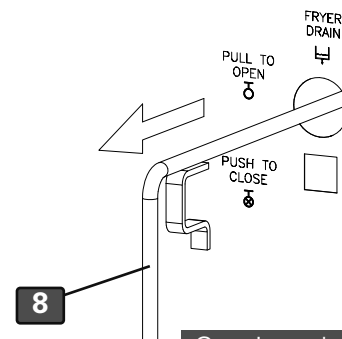

Continued next page

## 6-01. Boil Out Procedure (Continued)

13. Rinse and flush the Fry Pot thoroughly with tap water.
14. Dry fry pot with a clean dry towel.
15. Push and lock in the Drain Valve Handle to the CLOSE **9** position.
16. Clean Filter Pan and replace Filter Paper; follow directions in Section 6-2, Cleaning the Filter Pan and replacing Filter Paper after the Boil Out.
17. Re install Filter Pan Cover .
18. Position Filter Pan **10** under unit and connect Filter Pan Quick Disconnect Hose **11**.
19. To begin cooking on the unit, see Section 5-2.

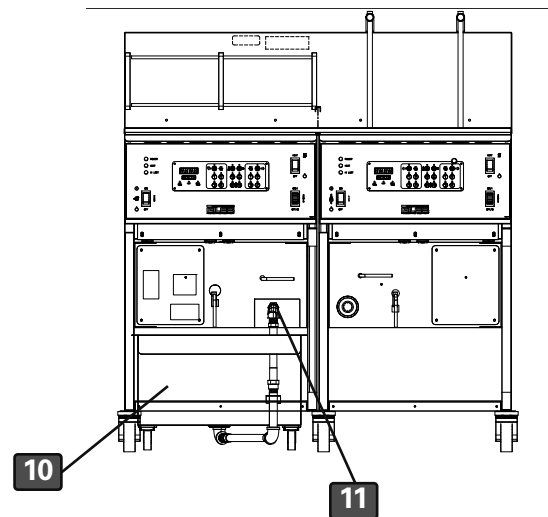
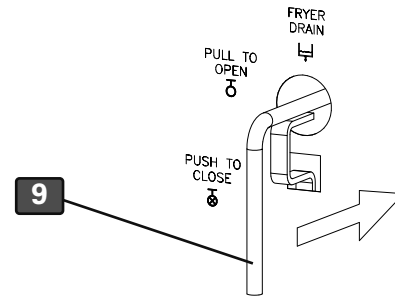

**6-02. Cleaning the Filter Pan and replacing Filter Paper after Boil Out**

This section explains the process for cleaning the Filter Pan and the replacement of the Filter Paper. This process should be carried out each time you perform a Boil Out Procedure (Section 5-5).

**CAUTION**

- Use Thermal Mitts for protection from hot parts.

1. Follow the Normal Shut-Down procedure, see Section 5-5.
2. Disconnect Quick Disconnect hose, remove the Filter Pan **1** and the Filter Pan Cover .
3. Clean Filter Pan Cover thoroughly, using a biodegradable, none toxic cleaner.
4. Remove and clean Crumb Screen Screen **3** , using a biodegradable, none toxic cleaner.
5. Using metal Crumb Scoop provided with the unit, remove the accumulated breading and residue from the edge of the Hold Down Frame and surface of the Filter Paper. This will help prevent breading from getting underneath the new Filter Paper, which could prevent a good seal.
6. Turn the four Levers **4** to disengage the Hold-Down Frame **5** from the bottom of Filter Pan.
7. Remove the Hold Down Frame **5** , then clean and dry thoroughly.
8. Grasp one end of the Filter Paper **6** and carefully roll up both sheets, then discard them.
9. Remove the Screen **7** , then clean and dry thoroughly.
10. Thoroughly clean and dry the Filter Pan **8** .
11. Reassemble the Filter Pan using (2) new sheets of Filter Paper.
12. Reinstall Filter Pan Cover, then the Filter Pan Assembly into the unit.

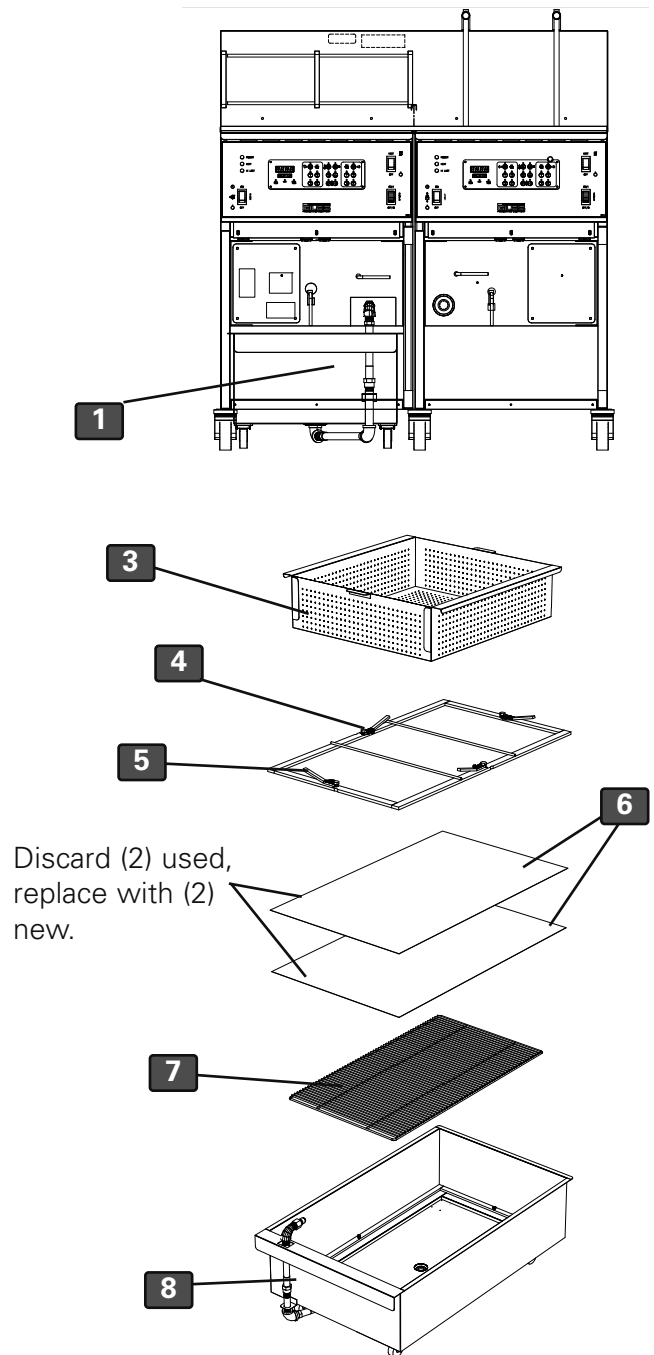

## 6-03. Cleaning the Filter Pan and replacing the Filter Paper daily

This section explains the process for cleaning the Filter Pan and the replacement of the Filter Paper daily. This process should be carried out daily.

### **CAUTION**

- Use Thermal Mitts for protection from hot parts.

1. Follow the Normal Shut-Down procedure, see Section 5-5.
2. Disconnect Quick Disconnect hose, remove the Filter Pan **1** and the Filter Pan Cover .
3. Clean Filter Pan Cover thoroughly, using a biodegradable, none toxic cleaner.
4. Remove and clean Crumb Screen Screen **3**, using a biodegradable, none toxic cleaner.
5. Using metal Crumb Scoop provided with the unit, remove the accumulated breadding and residue from the edge of the Hold Down Frame and surface of the Filter Paper. This will help prevent breadding from getting underneath the new Filter Paper, which could prevent a good seal.
6. Turn the four Levers **4** to disengage the Hold-Down Frame **5** from the bottom of Filter Pan.
7. Remove the Hold-Down Frame **5**, then clean and dry thoroughly.
8. Grasp top sheet **6** of Filter Paper by one end, carefully roll up and discard.
9. Grasp bottom sheet **7** of Filter Paper by both ends and remove; retain for reuse.
10. Remove the Screen **9**, then clean and dry thoroughly.
11. Thoroughly clean and dry the Filter Pan **10**.
12. Reassemble the Filter Pan using (1) new sheet of Filter Paper **8**, placed under maintained sheet.
13. Reinstall Filter Pan Cover, then the Filter Pan Assembly into the unit.

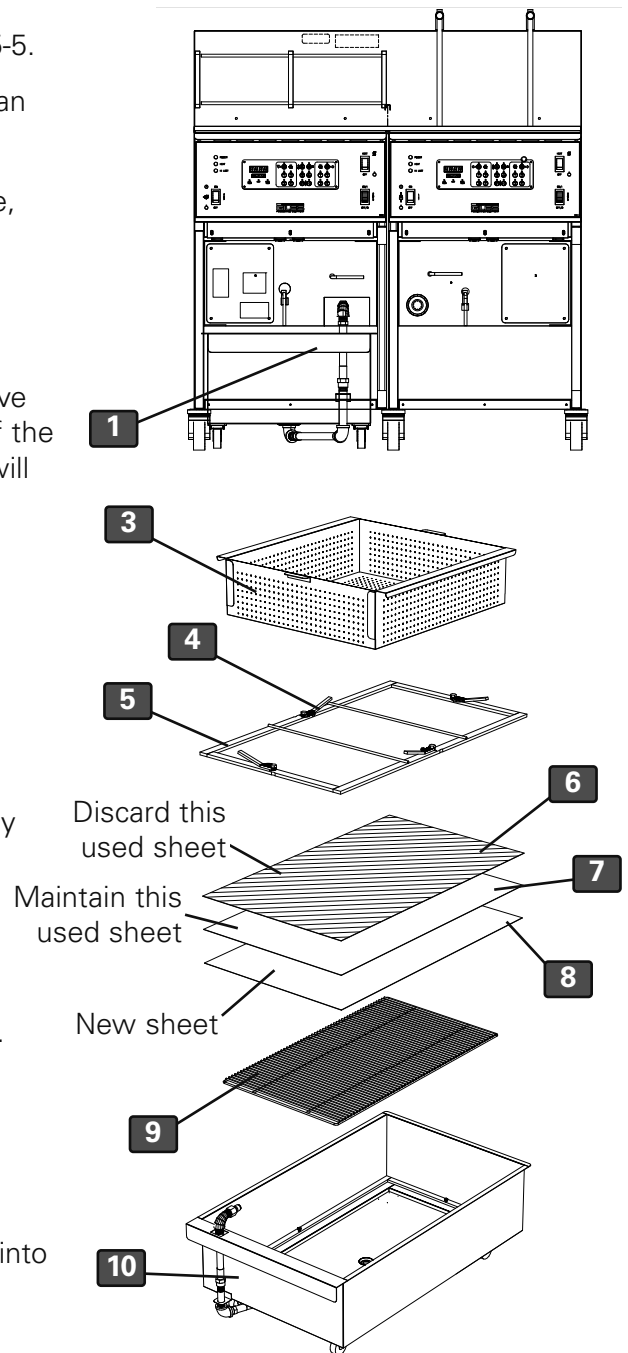



**Notes:**

## 7. Troubleshooting

This section describes troubleshooting procedures for the unit. Refer to the wiring diagrams in Section 9 for more detailed analysis.

7-01. Temperature Control System		
Problem	Probable Cause	Repair Procedure
<b>FRYER WILL NOT TURN ON:</b> No power light	A. Not connected to power source.	A. Connect to power source.
	B. Bad fuse or circuit breaker.	B. Check fuse or breaker.
	C. Fuse holder cracked.	C. Replace fuse holder.
	D. Power switch bad.	D. Replace Power Switch.
	E. Improper supply voltage.	E. Connect to proper voltage source.
<b>FRYER WILL NOT HEAT:</b> Power light on. Heat light not on.	A. Heat Switch not in Heat position.	A. Place Heat Switch in Heat position.
<b>FRYER WILL NOT HEAT:</b> Power light on. Heat Switch in Heat position. Heat light not on.	A. Controller programmed below present oil temperature.	A. Set temperature controller to desired temperature.
	B. Drain Valve open.	B. Close Drain Valve. Press Alarm Reset Button on Controller.
	C. Cooking computer faulty.	C. Replace Cooking Computer.
	D. Variable probe shorted or open.	D. Replace Probe.
	E. Loose wire.	E. Repair loose wire.
	F. Contactor failure.	F. Replace faulty contactor.
	G. Element bad.	G. Replace element.
	H. Heat Switch bad.	H. Replace Heat Switch.
	I. Low Oil Level	I. Turn Power Switch Off and Add Oil.

7-01. Temperature Control System (Continued)		
Problem	Probable Cause	Repair Procedure
<b>FRYER HEATING SLOW:</b> (slow recovery) Heat light stays on.	A. Incorrect Cooking procedures.	A. Consult Operations Manual for proper Cooking procedure.
	B. Element failing.	B. Replace bad Element.
	C. Contactor failing.	C. Replace Contactor.
	D. Loose Wire.	D. Repair Loose Wire.
	E. Low Supply Voltage.	E. Supply proper Voltage.
<b>FRYER HEATS SLOW:</b> (short cycling) Heat light off and on CONTINUOUSLY.	A. Low supply Voltage.	A. Supply proper Voltage.
	B. Variable probe touching element.	B. Reposition variable probe.
	C. Cooking Controller faulty.	C. Replace Cooking Controller.
<b>OIL TEMPERATURE ERRATIC:</b>	A. Probe bad.	A. Replace Probe.
	B. Contactor failing.	B. Replace Contactor.
	C. Cooking Controller faulty.	C. Replace Cooking Controller.
	D. Loose Wire.	D. Repair loose Wire.
<b>OIL SMOKING:</b>	A. Old Oil.	A. Change Oil.
	B. Over Temperature.	B. Check temperature setting.
	C. Dirty Element.	C. Clean Elements, using Fry Vat cleaning brush.
	D. Element failure.	D. Replace Element.
	E. Improper element voltage.	E. Supply proper Voltage.
	F. Low Oil level.	F. Keep Oil at FULL Level.



7-01. Temperature Control System (Continued)		
Problem	Probable Cause	Repair Procedure
<b>FRYER WILL NOT HEAT:</b> Power light on. Heat Switch in Heat position. High Limit light On.	A. Power surge.	A. Turn Power Switch off for 5 seconds.
	B. Sticking Contactor.	B. Replace Contactor.
	C. Bad High Limit Board.	C. Replace High Limit Board.
	D. High Limit Probe short or open.	D. Replace High Limit Probe.
	E. Line spikes or noise.	E. Filter Line or remove noise source.

7-02. Oil Filtration System		
Problem	Probable Cause	Repair Procedure
<b>OIL NOT RETURNING TO FRY POT:</b>	A. Pump Switch not in "Pump" position.	A. Place Selector Switch in "Filter/Pump" position.
	B. Air Leak (hose, fittings, filter paper).	B. Repair Air Leak.
	C. Pump Motor Bad.	C. Replace Pump Motor.
	D. Oil Pump Sticking.	D. Free Stuck Pump.
	E. Diverter Valve not in TO FRYER position.	E. Place Diverter Valve in TO FRYER position.
	F. Boil Out being run through Pump.	F. Disassemble and Re-Oil Pump.
	G. Old Oil allowed to sit in Pump.	G. Run Clean Oil through Pump.
	H. Oil cold or Oil below 200°F (93°C) in Filter Pan.	H. Remove Filter Pan and remove cold oil from Filter Pan.
	I. Filter Pan incorrectly assembled.	I. Assembly Filter Pan correctly.
	J. Dirty Filter Pan.	J. Clean Filter Pan.

**7-03. Basket Elevator System (Basket Elevator Option Only)**

Problem	Probable Cause	Repair Procedure
<b>BASKET WILL NOT GO UP OR DOWN</b>	A. Power not on.	A. Press Power Switch to ON position.
	B. Cooking Controller faulty.	B. Replace Cooking Controller.
	C. Elevator microswitch out of adjustment.	C. Adjust Elevator microswitch.
	D. Elevator microswitch bad.	D. Replace Elevator microswitch.
	E. Elevator Switch not in On position.	E. Press Elevator Switch to On position.
	F. Elevator Motor bad.	F. Replace Motor.

## 8. Parts List

This section lists various parts that are available for replacement on the unit.

### 8-01. Parts Ordering and Service Information

If you require assistance or need repairs, please contact your area developer for a service agency in your area. For further assistance, please contact the Giles Enterprises, Inc. corporate office at the following phone numbers:

**IN THE UNITED STATES, CANADA or MEXICO**

Please call **1-800-554-4537** during normal business hours, 8:00AM-5:00PM Central Time Zone. For emergency equipment repair service, after normal business hours, call 1-800-554-4537, extension 314.

**IN ALL OTHER COUNTRIES**

Please call **1-334-272-1457** during normal business hours, 8:00AM-5:00PM Central Time Zone; For emergency equipment repair service, after normal business hours call, 1-334-272-1457 extension 314.

**INTERNET**

Please visit our website on the world wide web at: [www.gilesent.com](http://www.gilesent.com).

The goal of the Giles team of professionals is to provide you with the highest quality of service and assistance. You can help us accomplish this by obtaining the following information and having it readily available when calling. The information is recorded on the Data Plate attached to the side of the unit.

MODEL	<input type="text"/>	SERIAL NO.	<input type="text"/>
MODÈLE	<input type="text"/>	NO. DE SÉRIE	<input type="text"/>
VAC	<input type="text"/>	AMP	<input type="text"/>
VCA	<input type="text"/>	WATTS	<input type="text"/>
PHASE	<input type="text"/>	HZ.	<input type="text"/>
	<input type="text"/>	DATE	<input type="text"/>
<b>GILES ENTERPRISES, INC.</b>			
1-800-288-1555			
<small>64230-C</small>			

The area below may be helpful in recording information from the Data Plate for use as a quick reference.

**Model Number:** \_\_\_\_\_

**Serial Number:** \_\_\_\_\_

**Phase:** \_\_\_\_\_

**Voltage:** \_\_\_\_\_

**Be ready to describe the nature of the problem.**



8-02. Right Side EOF-20 Left Control Panel & Front Header

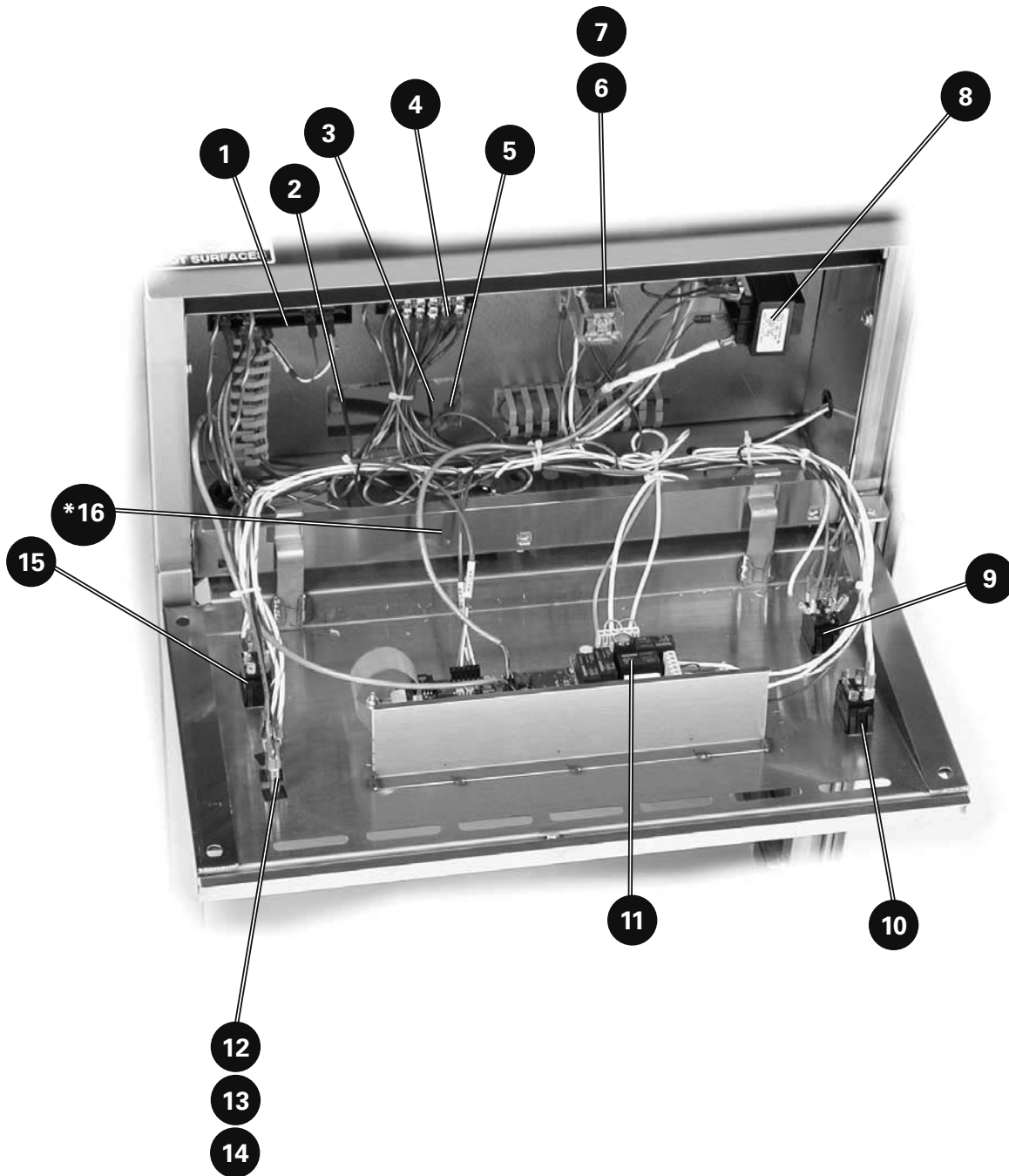

\* -Not shown

**8-02. EOF-20 Control Panel & Front Header**

Item	Part No.	Qty.	Description
01	23755	1	THERMOSTAT, SAFETY, WATLOW, 450DEG
02	20315	1	THERMOCOUPLE, 13.5", STRAIGHT, J TYPE, <b>(REQUIRES P/N 45111 FERRULE)</b>
03	20315	1	THERMOCOUPLE, 13.5", STRAIGHT, J TYPE, <b>(REQUIRES P/N 45111 FERRULE)</b>
04	23751	1	TERMINAL BLOCK, MA106, 6 POLE
05	24222	1	THERMOCOUPLE, VARIABLE, SINGLE, <b>(REQUIRES P/N 45111 FERRULE)</b>
06	21101	1	SOCKET, RELAY, 8 PIN, 300V, 10A, CR-5
07	21102	1	RELAY, 8 PIN, 240V, 10A, CR-5
08	37616	1	TRANSFORMER & ADAPTER PLATE, ASSY, 60HZ
09	21190	1	SWITCH, ROCKER, ON-OFF, 250V, 20A, DPST
10	21052	1	SWITCH, ROCKER, ON-NONE-ON, 250V, 20A, DPDT
11	20326	1	CONTROLLER, COMPUTER, WATLOW, TIME/TEMP
12	38214	1	LIGHT, INDICATOR, RED, 250VAC
13	38213	1	LIGHT, INDICATOR, ORANGE, 250V
14	38215	1	LIGHT, INDICATOR, GREEN, 250VAC
15	21052	1	SWITCH, ROCKER, ON-NONE-ON, 250V, 20A, DPDT
16	23782	1	SONALERT, 250V, CONTINUOUS BEEP

\* -Not shown



8-03. EOF-20 Left Front Lower Cabinet

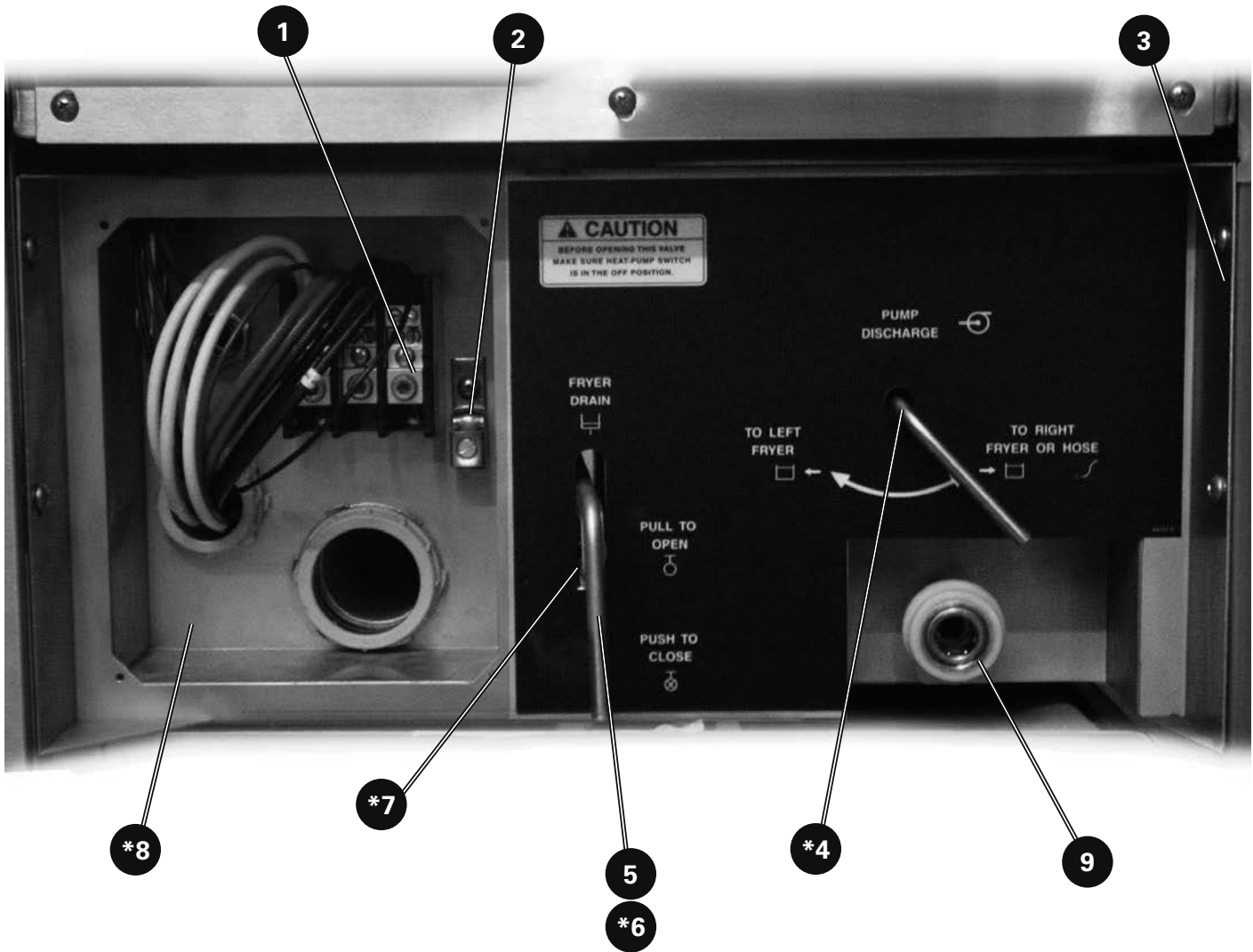

\* -Not shown

**8-03. EOF-20 Front Lower Cabinet**

Item	Part No.	Qty.	Description
01	21164	1	POWER DIST,TERMINAL BLOCK
02	21051	1	LUG, 1/0-2/0 COPPER TERMINAL 125A 1/4" BOLT HOLE
*03	35151	1	WELD ASSY., DOOR FINAL
*04	45755	1	VALVE, 3-WAY, 1/2NPT
05	39258	1	HANDLE,DRAIN PULL,WELD ASSY
*06	40818	1	VALVE,BALL,1-1/4",DRAIN,SINGLE THREADEND
*07	21157	1	SWITCH, LIMIT, 15A, 250V DRAIN SWITCH
*08	35236	1	COVER, SERVICE CONNECTION
09	41900	1	COUPLING, QUICK DICONNECT,FEMALE,FIL PAN

\* -Not shown



8-04. EOF-20 Left Rear Lower Cabinet

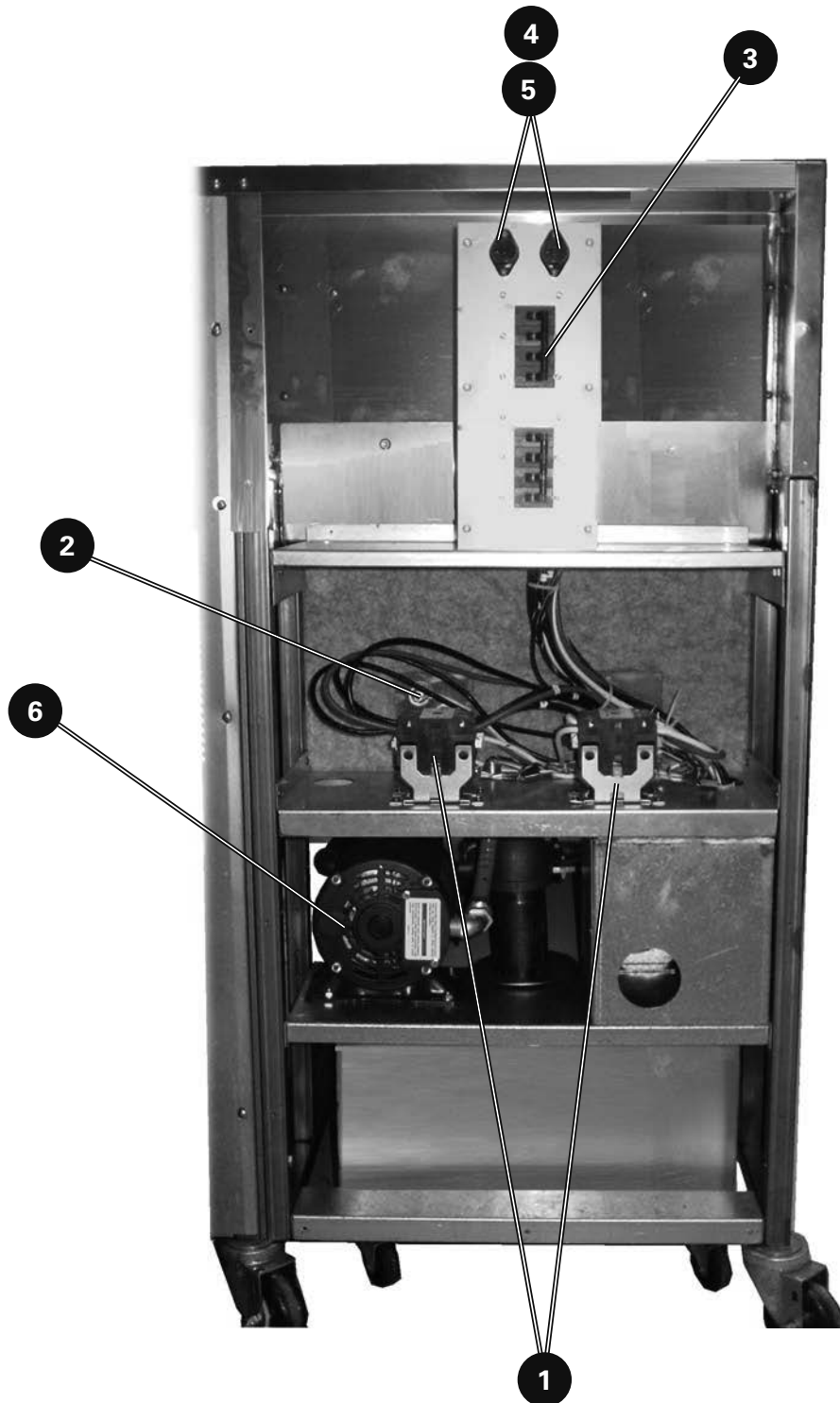

\* -Not shown

REF #: 60221-03



## 8-04. EOF-20 Left Rear Lower Cabinet

Item	Part No.	Qty.	Description
01	32260	2	CONTACTOR,ASSY,4 POLE,40A,W/QUENCH
02	20003	4	ELEMENT, 6000W, 208V, EOF-20
02	20004	4	ELEMENT, 6000W 240V, EOF-20
02	24257	4	ELEMENT, 6000W 480V, EOF-20
03	20513	2	BREAKER, CIRCUIT,277V,50A,6 POLE
04	21900	2	FUSE, 15-AMP, SC-15
05	21950	2	HOLDER, FUSE, 300V, 15A
06	70912	1	PUMP/MOTOR ASSY

\* -Not shown



8-05. EOF-20 Right Control Panel & Front Header

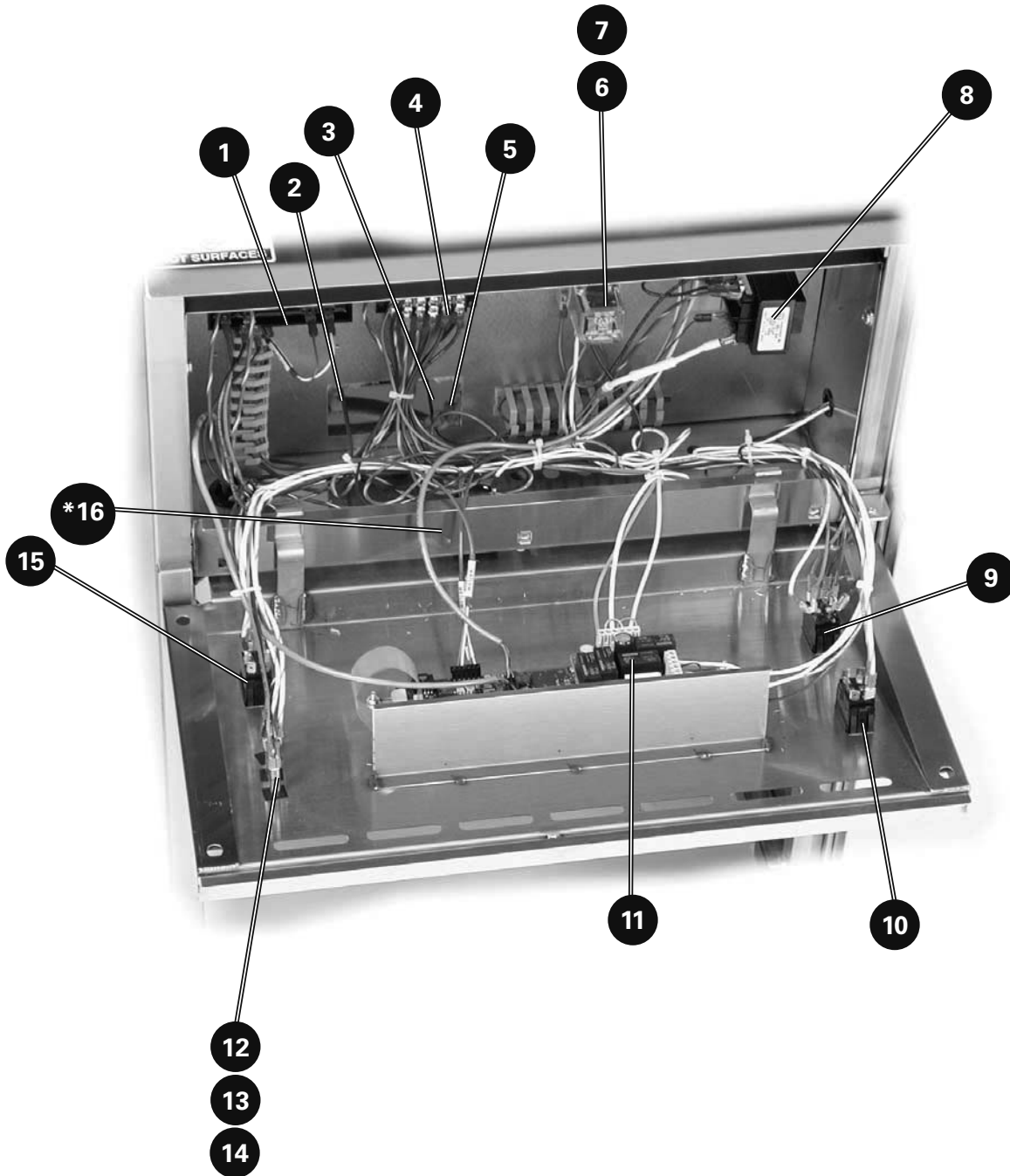

\* -Not shown

**8-05. EOF-24 Control Panel & Front Header**

Item	Part No.	Qty.	Description
01	23755	1	THERMOSTAT, SAFETY, WATLOW, 450DEG
02	20315	1	THERMOCOUPLE, 13.5", STRAIGHT, J TYPE, <b>(REQUIRES P/N 45111 FERRULE)</b>
03	24222	1	THERMOCOUPLE, VARIABLE, SINGLE, WOG-D, <b>(REQUIRES P/N 45111 FERRULE)</b>
04	20315	1	THERMOCOUPLE, 13.5", STRAIGHT, J TYPE, <b>(REQUIRES P/N 45111 FERRULE)</b>
05	23751	1	TERMINAL BLOCK, MA106, 6 POLE
06	21101	1	SOCKET, RELAY, 8 PIN, 300V, 10A
07	21102	1	RELAY, 8 PIN, 240V, 10A
08	37616	1	TRANSFORMER & ADAPTER PLATE, ASSY, 60HZ
09	21190	1	SWITCH, ROCKER, ON-OFF, 250V, 20A, DPST
10	21052	1	SWITCH, ROCKER, ON-NONE-ON, 250V, 20A, DPDT
11	20326	1	CONTROLLER, COMPUTER, WATLOW, TIME/TEMP
12	38214	1	LIGHT, INDICATOR, RED, 250VAC
13	38213	1	LIGHT, INDICATOR, ORANGE, 250V
14	38215	1	LIGHT, INDICATOR, GREEN, 250VAC
15	23782	1	SONALERT, 250V, CONTINUOUS BEEP

\* -Not shown



8-06. EOF-20 Right Front Lower Cabinet

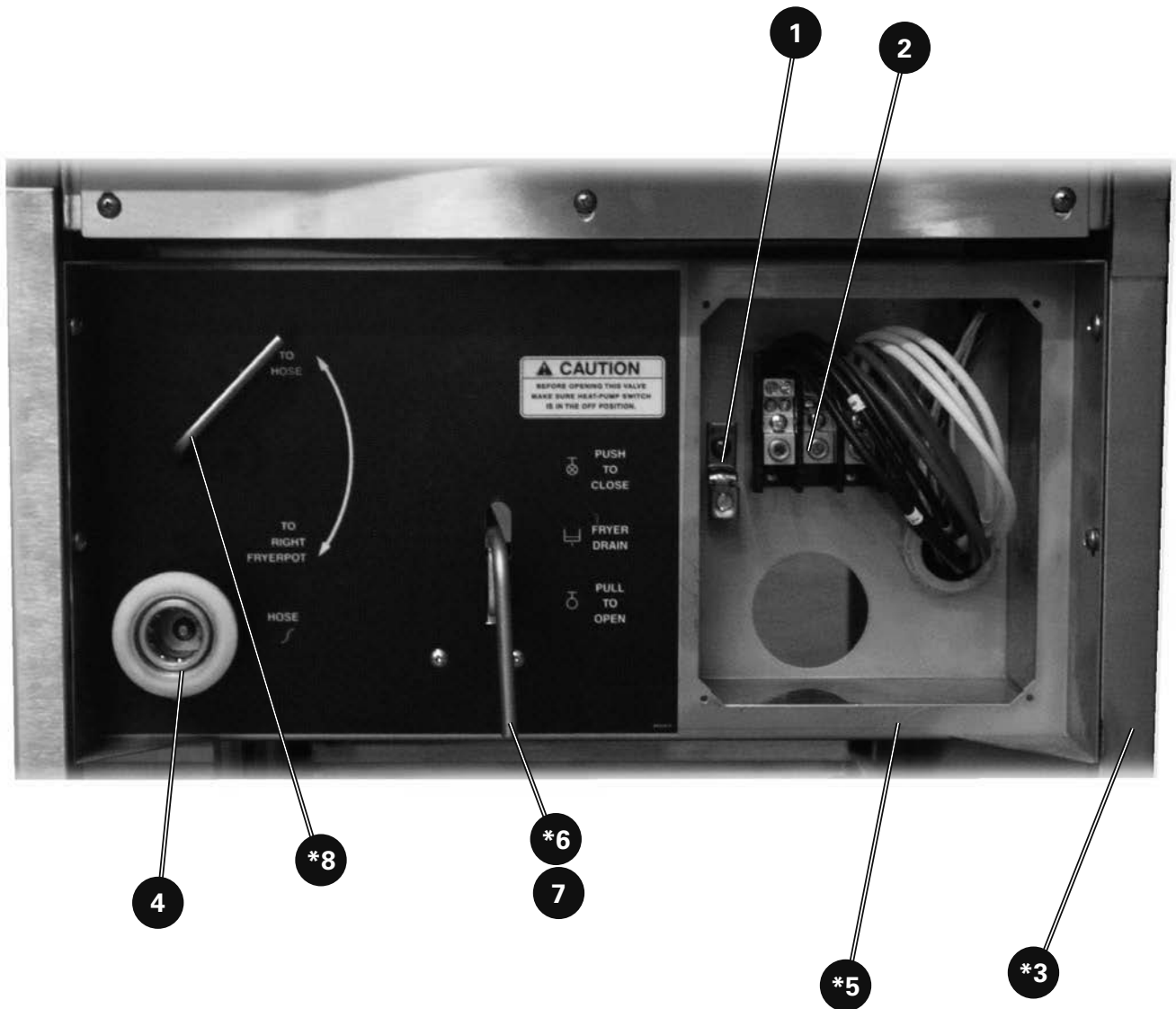

\* -Not shown



## 8-06. EOF-24 Front Lower Cabinet

Item	Part No.	Qty.	Description
01	21051	1	LUG, 1/0-2/0 COPPER TERMINAL 125A 1/4" BOLT HOLE
02	21164	1	POWER DIST,TERMINAL BLOCK
*03	35151	1	DOOR FINAL, WELD ASSY
04	41699	1	COUPLING, QUICK DISCONNECT, FEMALE
*05	35236	1	COVER, SERVICE CONNECTION
*06	40818	1	VALVE,BALL,1-1/4",DRAIN,SINGLE THREADEND
07	39260	1	HANDLE,DRAIN PULL, WELD ASSY
*08	40784	1	VALVE,BALL,1/2",S/S



8-07. EOF-24 Rear Lower Cabinet

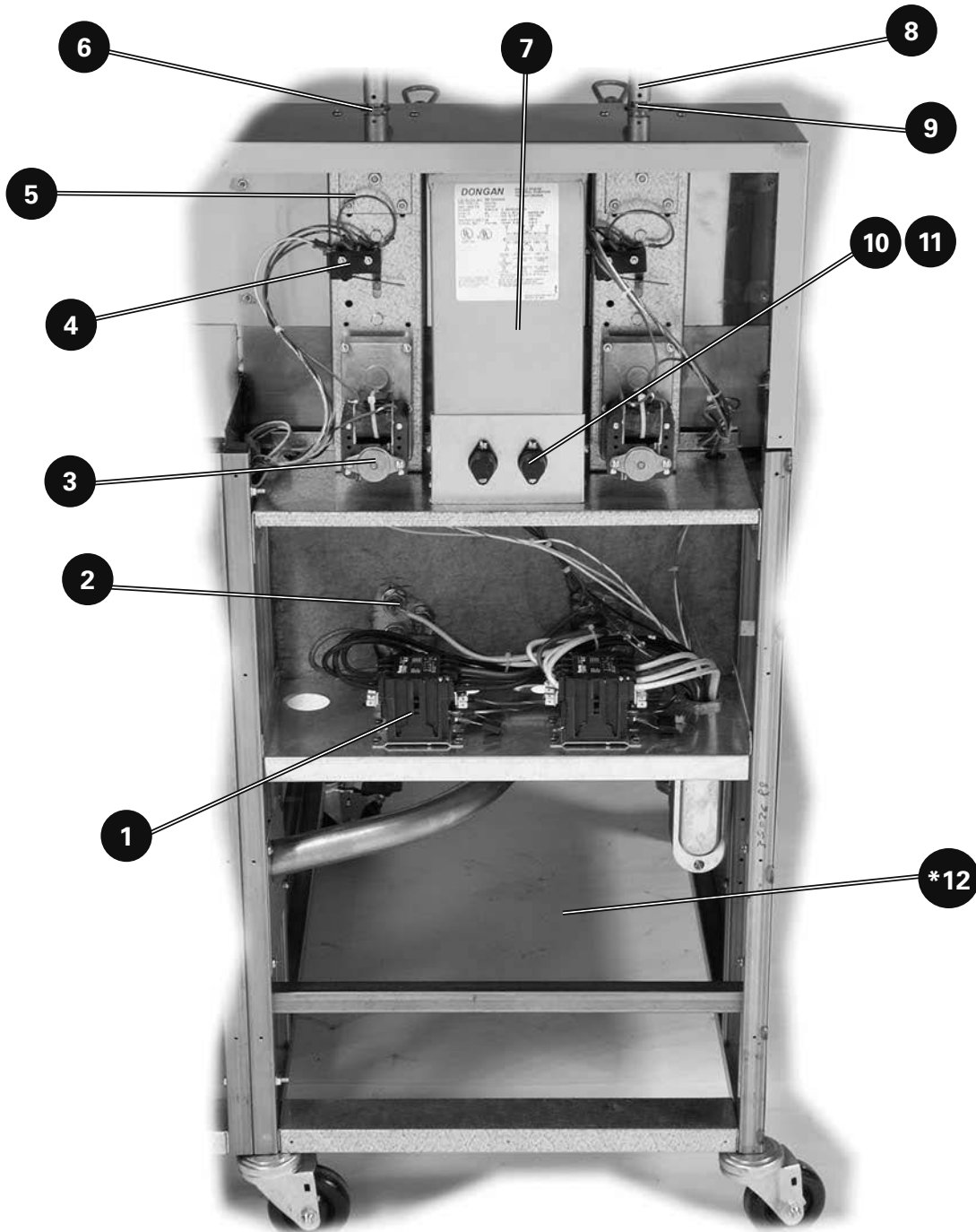

\* -Not shown

**8-07. EOF-20 Right Rear Lower Cabinet**

Item	Part No.	Qty.	Description
01	32260	2	CONTACTOR,ASSY,4 POLE,40A,W/QUENCH
02	20003	4	ELEMENT, 6000W, 208V, EOF-20
02	20004	4	ELEMENT, 6000W 240V, EOF-20
02	24257	4	ELEMENT, 6000W 480V, EOF-20
03	32158	2	ELEV MOTOR & QUENCHARC, ASSY 208/240
04	22878	2	SWITCH, 250V, 10A, DOUBLE SNAP ACTION
05	36457	2	ELEVATOR, BASKET, ASSY, EOF
06	39167	2	BRONZE BEARING WITH GROOVE
07	24277	1	TRANSFORMER, 1.5kw, 480V TO 240V, (480V MODEL ONLY)
07*	20513	2	BREAKER, CIRCUIT,50A,277V,6 PL, SER TRIP (208V OR 240V MODEL ONLY)
08	39403	2	BASKET CARRIER,. ASSY
09	35052	2	BAR, ELEVATOR LIFT, EOF
10	21900	2	FUSE, 15AMP, SC-15
11	21950	2	HOLDER, FUSE, 300V, 15A, SC 0 TO 15
*12	35125	1	WELD ASSY., BACK PANEL

\* -Not shown



8-08. Filter Pan

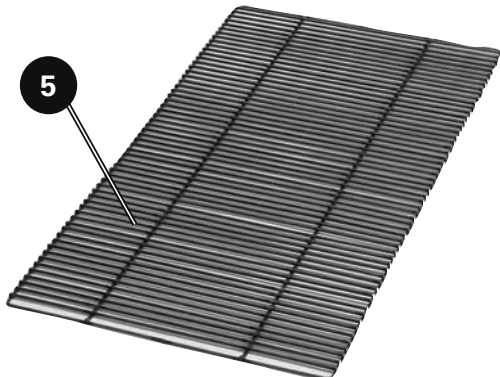
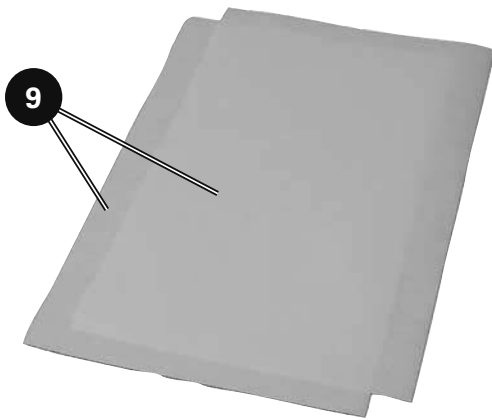
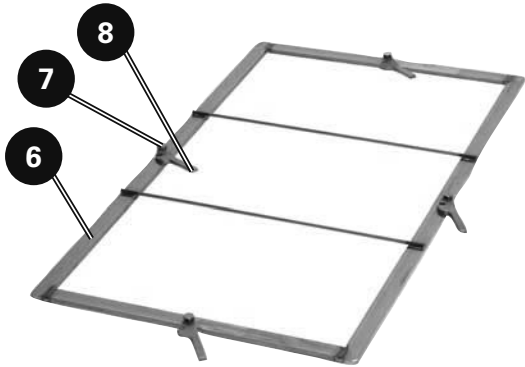

\* -Complete assembly



**8-08. Filter Pan**

Item	Part No.	Qty.	Description
01	40649	4	CASTER, SWIVEL, 2.563IN, PLATE MNT
02	43307	1	HOSE, 1/2NPT X 7.625, STEEL BRAIDED
03	44150	1	FITTING, BRASS,MALE,1/2NPT,QUICK DISCONN
04	30039-8	4	STUD, FILTER PAN SUPPORT FRAME
05	40181	1	SCREEN, FILTER PAN (EOF-20)
06	35810	1	FRAME, FILTER PAPER HOLD DWN, WELD ASSY
07	30040-4	4	STUD, FILTER PAN HOLD DOWN FRAME
08	54526	4	CASTING, LEVER,FILTER PAN,HOLDDOWN FRAME
09	60709	2	PAPER, FILTER, GFSE, 15-3/8 X 32-3/8
10	36213	1	CRUMB SCREEN, WELD ASSY, FILTER PAN
11	43302	1	HOSE, 1/2 NPT X 18.000, STEEL BRAIDED
12*	35813	1	FILTER PAN, FINAL, ASSY, EOF-20/20, (P/N 36213 NOT INCLUDED)

\* -Complete assembly



**Notes:**

## 9. *Wiring Diagram*

The following section contains various Wiring Diagrams for the unit. Please check the Serial Plate on the rear of each unit, as shown below, for the units Model Name, Voltage, Hertz, and Phase.

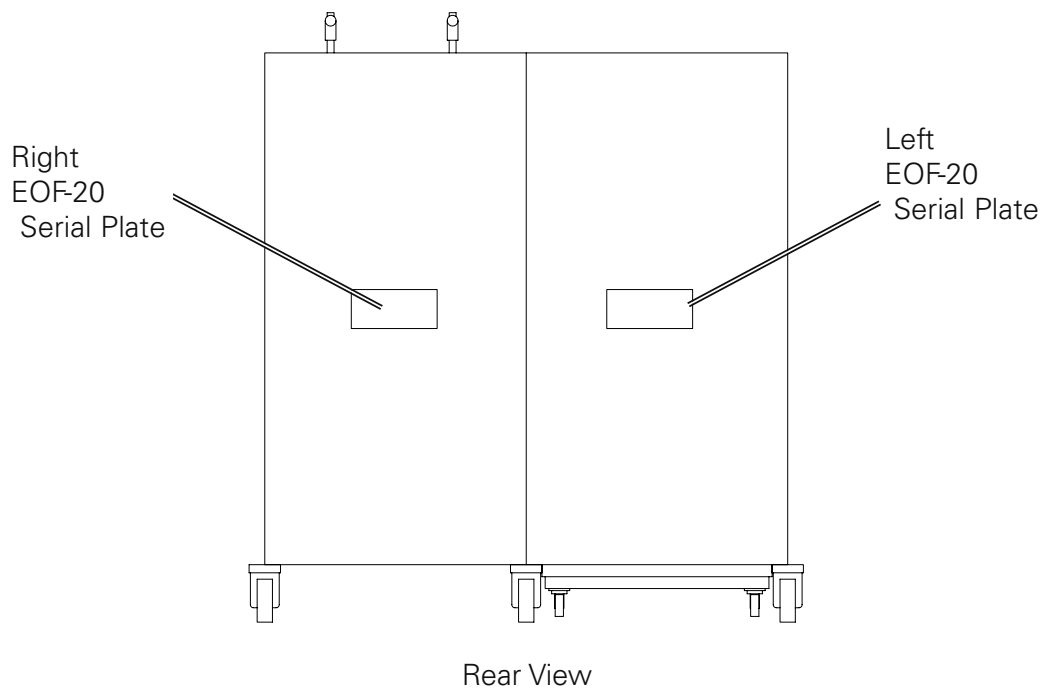

9-01. Wiring Diagram EOF 20/20 Left Fryer 208-240/60/3

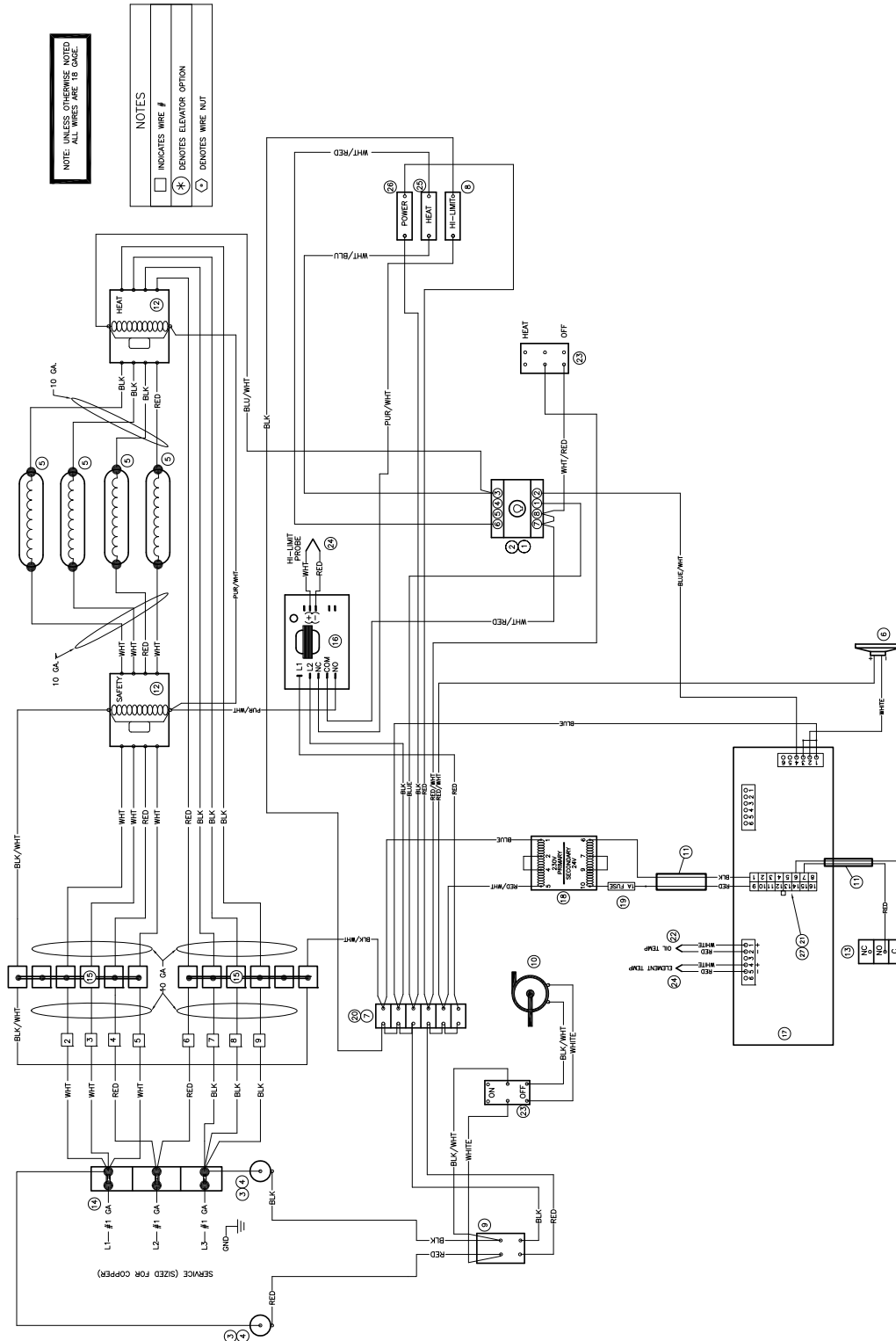

39391-D  
9/6/07

WIRING DIAGRAM EOF-20/20 LEFT FRYER 208-240/60/3  
WITH SUPPLY POWER FOR FILTER PUMP/COMPUTER COOKER/LOW OIL PROTECTION

## 9-01. BOM for Wiring Diagram EOF 20/20 Left Fryer 208-240/60/3

Item	Part No.	Qty.	Description
1	21102	1	RELAY, 8 PIN, 240V, 10A
2	21101	1	SOCKET, RELAY, 8 PIN, 300V, 10A
3	21900	2	FUSE, 15-AMP, SC-15
4	21950	2	HOLDER, FUSE
5	20004	4	ELEMENT, ROUND, 6000W, 240V,
5	20003	4	ELEMENT, ROUND, 6000W, 208V
6	23782	1	SONALERT, 250V, CONTINOUS BEEP
7	23751	1	TERMINAL BLOCK, MA106
8	20402	1	INDICATOR LIGHT, RED
9	21190	1	SWITCH, ROCKER, ON-OFF
10	70912	1	PUMP/MOTOR ASSY
11	25200	1	WIRE, 22-GA, MULTI-LEAD
12	32260	2	CONTACTOR, ASSY, 4-POLE
13	21157	1	SWITCH, LIMIT, 15A, 250V DRAIN SWITCH
14	21164	1	BLOCK, POWER DISTRIBUTION
15	20513	2	BREAKER, CIRCUIT
16	23755	1	THERMOSTAT, SAFETY, WATLOW, 450DEG
17	20326	1	CONTROLLER, N7
18	37616	1	TRANSFORMER
19	38365	1	ASSY, FUSE
20	21196	4	TERMINAL, BLOCK, JUMPER
21	20327	1	BOARD CONNECTOR, 16-PIN
22	23900	1	THERMOCOUPLE - J, 3-IN, SINGLE
23	21052	2	SWITCH,ROCKER,ON-OFF-ON
24	20315	1	THERMOCOUPLE, J-TYPE, STRAIGHT, 13.5-IN
25	20399	1	INDICATOR LIGHT, AMBER
26	20398	1	INDICATOR LIGHT, GREEN
27	20328	4	PIN, CONNECTOR

9-02. Wiring Diagram EOF 20/20 Right Fryer 208-240/60/3

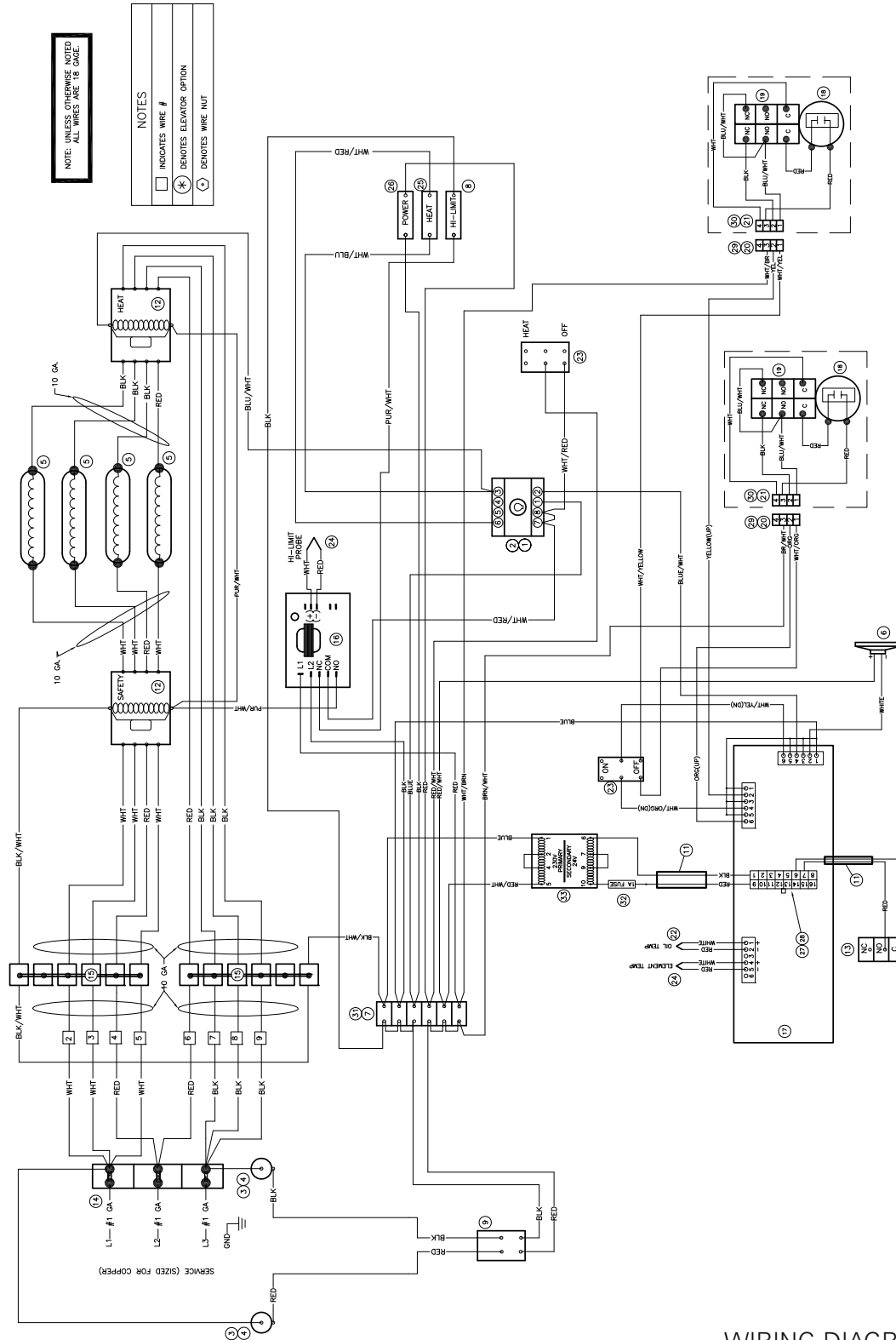

NOTE: UNLESS OTHERWISE NOTED ALL WIRES ARE 18 GAGE.

- NOTES
- INDICATES WIRE #
  - ⊕ DENOTES ELEVATOR OPTION
  - ⊖ DENOTES WIRE NUT

WIRING DIAGRAM RIGHT FRYER EOF-20/20 208-240/60/3 WITH SUPPLY POWER FOR FILTER PUMP/COMPUTER COOKER/LOW OIL PROTECTION

39392-D  
9/6/07

## 9-02. BOM for Wiring Diagram EOF 20/20 Right Fryer 208-240/60/3

Item	Part No.	Qty.	Description
1	21102	1	RELAY, 8 PIN, 240V, 10A
2	21101	1	SOCKET, RELAY, 8 PIN, 300V, 10A
3	21900	2	FUSE, 15-AMP, SC-15
4	21950	2	HOLDER, FUSE
5	20004	4	ELEMENT, ROUND, 6000W, 240V,
5	20003	4	ELEMENT, ROUND, 6000W, 208V
6	23782	1	SONALERT, 250V, CONTINOUS BEEP
7	23751	1	TERMINAL BLOCK, MA106
8	20402	1	INDICATOR LIGHT, RED
9	21190	1	SWITCH, ROCKER, ON-OFF
10	-----	-	-----
11	25200	1	WIRE, 22-GA, MULTI-LEAD
12	32260	2	CONTACTOR, ASSY, 4-POLE
13	21157	1	SWITCH, LIMIT, 15A, 250V DRAIN SWITCH
14	21164	1	BLOCK, POWER DISTRIBUTION
15	20513	2	BREAKER, CIRCUIT
16	23755	1	THERMOSTAT, SAFETY, WATLOW, 450DEG
17	20326	1	CONTROLLER, N7
18	36457	2	ASSY, MOTOR & QUENCHARC, ELEV
19	22878	2	SWITCH, 250V, 10A, DOUBLE SNAP ACTION
20	20007	2	CONNECTOR, 4-PIN, IN-LINE RECEPTACLE
21	20008	2	CONNECTOR, 4-PIN, IN-LINE PLUG
22	23900	1	THERMOCOUPLE - J, 3-IN, SINGLE
23	21052	2	SWITCH,ROCKER,ON-OFF-ON
24	20315	1	THERMOCOUPLE, J-TYPE, STRAIGHT, 13.5-IN
25	20399	1	INDICATOR LIGHT, AMBER
26	20398	1	INDICATOR LIGHT, GREEN
27	20328	4	PIN, CONNECTOR
28	20327	1	BOARD CONNECTOR, 16-PIN
29	21291	6	CONNECTOR, PIN, FEMALE
30	21290	6	CONNECTOR, PIN, MALE
31	21196	4	TERMINAL, BLOCK, JUMPER
32	38365	1	ASSY, FUSE, CONTROLLER
33	37616	1	TRANSFORMER





## 9-03. BOM for Wiring Diagram EOF 20/20 Left Fryer 480/60/3

Item	Part No.	Qty.	Description
1	21102	1	RELAY, 8 PIN, 240V, 10A
2	21101	1	SOCKET, RELAY, 8 PIN, 300V, 10A
3	21900	2	FUSE, 15-AMP, SC-15
4	21950	2	HOLDER, FUSE
5	24257	4	ELEMENT, ROUND, 6000W, 480V
6	23782	1	SONALERT, 250V, CONTINOUS BEEP
7	23751	1	TERMINAL BLOCK, MA106
8	20402	1	INDICATOR LIGHT, RED
9	21190	1	SWITCH, ROCKER, ON-OFF
10	24277	1	TRANSFORMER, 1.5kw, 480V TO 240V
11	25200	1	WIRE, 22-GA, MULTI-LEAD
12	32260	2	CONTACTOR, ASSY, 4-POLE
13	21157	1	SWITCH, LIMIT, 15A, 250V DRAIN SWITCH
14	21164	1	BLOCK, POWER DISTRIBUTION
15	70912	1	PUMP/MOTOR ASSY
16	23755	1	THERMOSTAT, SAFETY, WATLOW, 450DEG
17	20326	1	CONTROLLER, N7
18	37616	1	TRANSFORMER
19	38365	1	ASSY, FUSE
20	21196	4	TERMINAL, BLOCK, JUMPER
21	20327	1	BOARD CONNECTOR, 16-PIN
22	23900	1	THERMOCOUPLE - J, 3-IN, SINGLE
23	21052	2	SWITCH,ROCKER,ON-OFF-ON
24	20315	1	THERMOCOUPLE, J-TYPE, STRAIGHT, 13.5-IN
25	20399	1	INDICATOR LIGHT, AMBER
26	20398	1	INDICATOR LIGHT, GREEN
27	20328	4	PIN, CONNECTOR



## 9-04. BOM for Wiring Diagram EOF 20/20 Right Fryer 480/60/3

Item	Part No.	Qty.	Description
1	21102	1	RELAY, 8 PIN, 240V, 10A
2	21101	1	SOCKET, RELAY, 8 PIN, 300V, 10A
3	21900	2	FUSE, 15-AMP, SC-15
4	21950	2	HOLDER, FUSE
5	24257	4	ELEMENT, ROUND, 6000W, 480V
6	23782	1	SONALERT, 250V, CONTINOUS BEEP
7	23751	1	TERMINAL BLOCK, MA106
8	20402	1	INDICATOR LIGHT, RED
9	21190	1	SWITCH, ROCKER, ON-OFF
10	24277	1	TRANSFORMER, 1.5kw, 480V TO 240V
11	25200	1	WIRE, 22-GA, MULTI-LEAD
12	32260	2	CONTACTOR, ASSY, 4-POLE
13	21157	1	SWITCH, LIMIT, 15A, 250V DRAIN SWITCH
14	21164	1	BLOCK, POWER DISTRIBUTION
15	37616	1	TRANSFORMER
16	23755	1	THERMOSTAT, SAFETY, WATLOW, 450DEG
17	20326	1	CONTROLLER, N7
18	36457	2	ASSY, MOTOR & QUENCHARC, ELEV
19	22878	2	SWITCH, 250V, 10A, DOUBLE SNAP ACTION
20	20007	2	CONNECTOR, 4-PIN, IN-LINE RECEPTACLE
21	20008	2	CONNECTOR, 4-PIN, IN-LINE PLUG
22	23900	1	THERMOCOUPLE - J, 3-IN, SINGLE
23	21052	2	SWITCH,ROCKER,ON-OFF-ON
24	20315	1	THERMOCOUPLE, J-TYPE, STRAIGHT, 13.5-IN
25	20399	1	INDICATOR LIGHT, AMBER
26	20398	1	INDICATOR LIGHT, GREEN
27	20328	4	PIN, CONNECTOR
28	20327	1	BOARD CONNECTOR, 16-PIN
29	21291	6	CONNECTOR, PIN, FEMALE
30	21290	6	CONNECTOR, PIN, MALE
31	21196	4	TERMINAL, BLOCK, JUMPER
32	38365	1	ASSY, FUSE, CONTROLLER



**Notes:**



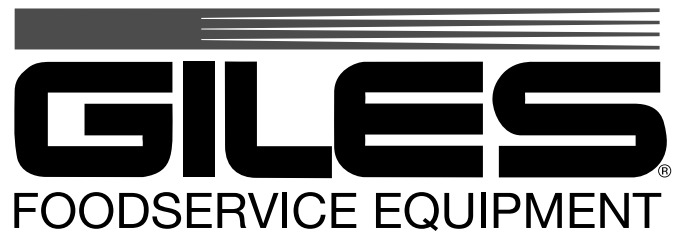

**Giles Enterprises, Inc.**

2750 Gunter Park Drive West • Montgomery, Al 36109 USA  
(334) 272-1457 • Service Hotline 1-800-554-4537 (USA & Canada Only) • FAX (334) 272-3561 • [www.gilesent.com](http://www.gilesent.com)

Form No. 60437 (Release date: 11/99)(Revision date: 11/06/07)(Rev B)