

Operations & Service Manual

FSH-2,
FSH-2A-99



Model: FSH-2A-99



Giles Enterprises, Inc.

An ISO 9001 Registered Company • Committed to Quality
2750 Gunter Park Drive West • Montgomery, AL 36109 USA

Fax: 334.239.4117 • Website: www.gfse.com

Service Hotline (Toll Free): 800.554.4537 (USA & Canada Only)

Form No. 60200 (Release date: 07/98)(Revision Date: 09/30/12; Rev. G)



LIMITED WARRANTY

- Subject to the terms and conditions of this Limited Warranty as herein stated, all Giles Enterprises, Inc., Foodservice Equipment and parts purchased new from an authorized Giles Enterprises, Inc., representative are warranted as to defects in material or workmanship for a period of 24 months from the date of installation, provided, however, that with regard to labor costs in connection with this warranty, see below. All installations must be made by a qualified installing agency in accordance with all applicable codes and/or regulations in the jurisdiction in which installed. Limited warranty coverage is extended to the original owner only and is void if the unit is resold.
- During the Limited Warranty period, Giles Enterprises, Inc. will replace or recondition, at its factory, any part or parts of this unit which Giles Enterprises, Inc. inspectors judge defective, provided the unit has been subjected to normal usage, properly installed, operated and serviced. This Limited Warranty does not cover cosmetic damage, and damage due to acts of God, accident, misuse, alteration, negligence, abuse of the Giles Foodservice Equipment or the use of unorthodox repair methods. All parts replaced under this Limited Warranty carry only the unexpired term of this Limited Warranty. Limited Warranty service may be furnished only by an authorized Giles Enterprises, Inc., representative.
- If Limited Warranty service is requested, Giles Enterprises, Inc., will send factory-authorized service representatives to repair, recondition, replace or inspect units of its manufacture with such labor being rendered without cost to owner for twenty-four (24) months from the date of installation. Otherwise, service, including labor and transportation charges or other expenses, in connection with the removal or installation of any part or parts supplied under this Limited Warranty, are specified on the original sales contract between the purchaser and the authorized Giles Enterprises, Inc., representative.
- Giles Enterprises, Inc. reserves the right to change or improve its equipment and parts in any way without obligation to alter such equipment or parts previously manufactured.
- Giles Enterprises, Inc. makes no further warranties, express or implied including implied warranties of merchantability or fitness for a particular purpose, and has no other obligation or liability not specifically stated herein.
- Repair or replacement as provided under this Limited Warranty is the exclusive remedy. Giles Enterprises, Inc., shall not be liable for any incidental or consequential damages for breach of any express or implied warranty on this product, except to the extent prohibited by applicable law. Any implied warranty of merchantability or fitness for a particular purpose on this product is limited in duration to the duration of this Limited Warranty.
- Used Giles Enterprises, Inc., Foodservice Equipment or parts or Giles Enterprises, Inc., Foodservice Equipment or parts not purchased from an authorized Giles Enterprises, Inc., representative, carry no warranties, express or implied.

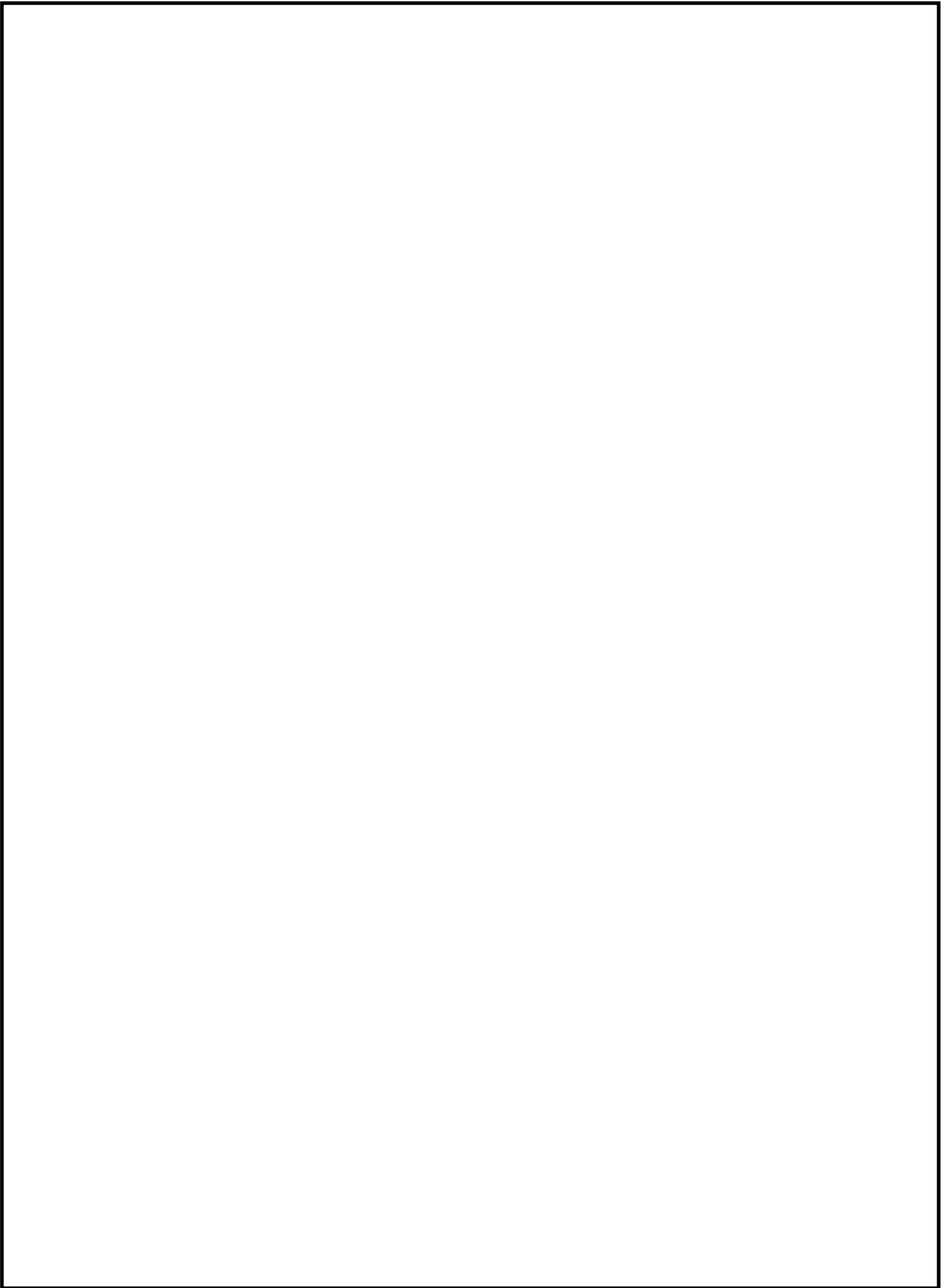

Safety	v
Safety Overview	v
Specific Safety Precautions	vi
1. Introduction	1
1-01. Construction	1
1-02. Standard Features	1
1-03. Optional Feature	1
1-04. Specifications	2
1-04.01. Overall Dimensions for FSH-2	2
1-04.02. Overall Dimensions for FSH-2A-99	3
1-05. Regulatory Listings	4
1-06. Unit Weights	4
2. Installation	5
2-01. Location	5
2-02. Unpacking	6
2-03. Electrical Requirements	6
2-03.01. Electrical Connections (Overview)	7
2-03.02. Hood Power Connection	7
2-03.03. Hood and Appliance Interlock Connection	8
2-03.04. Fire Alarm Connection	9
2-04. Limitations and Clearances	9
2-04.01. Fryer Limitations	9
2-04.02. Fryer Clearances for FSH-2	10
2-04.03. Fryer Clearances for FSH-2A-99	11
2-05. Fire Suppression System	12
2-05.01. Fusible Links and Gas Cartridge Location	12
2-05.02. Fire Extinguishing Nozzles and Tank Location	13
2-05.03. Manual Pull Diagram	14
2-06. Restraining Device	15
3. Overview	17
3-01. Filter Chamber	18
3-02. Control Panel	20
3-03. Accessories (Included)	22
4. Operation	25
4-01. Hood Operation	25
4-02. Hood Filters and Filter Maintenance	25
4-02.01. Hood Filter Table	25

4-02.02.	Baffle Filter Removal	26
4-02.03.	Baffle Filter Installation	27
4-02.04.	Baffle Filter Missing	28
4-02.05.	Baffle Filter Cleaning Procedure	28
4-02.06.	EAC Filter Removal	28
4-02.07.	EAC Filter Installation	29
4-02.08.	EAC Filter Status	29
4-02.09.	EAC Filter Cleaning	30
4-02.10.	Charcoal Filter Removal	31
4-02.11.	Charcoal Filter Installation	31
4-02.12.	Charcoal Filter Missing	32
4-02.13.	Charcoal Replacement Procedure	32
4-02.14.	Ultra Violet Lamp Removal	33
4-02.15.	Ultra Violet Lamp Installation	33
4-02.16.	Ultra Violet Lamp Cleaning	34
4-03.	Maintenance	35
4-03.01.	Monthly Interlock Check	35
4-03.02.	Semi-Annual Fire Suppression System Servicing	36
4-03.03.	Annual Fire Suppression System Servicing	36
4-03.04.	Annual UV System Servicing	36
4-03.05.	Twelve Year Suppression System Servicing	36
4-03.06.	Maintenance and Service Log	37
5.	General Hood Cleaning	39
5-01.	Weekly Cleaning	39
5-02.	Quarterly Cleaning	39
6.	Troubleshooting	41
6-01.	Troubleshooting Procedures	41
7.	Parts List	43
7-01.	Parts Ordering and Service Information	43
7-02.	Ventless Hood - Front	44
7-03.	Ventless Hood - Rear	46

Safety

Safety Overview

The instructions contained in this manual have been prepared to aid you in learning the proper procedures for installing and servicing your new unit.

Throughout this manual, safety precautions are identified through the use of the safety alert symbol and three signal words: **DANGER, WARNING**, and **CAUTION**. All safety alert information precedes the step(s) to which they apply. Suggested, recommended, or other noteworthy information is identified through the use of **NOTES**. Additionally, certain words are used to indicate a specific meaning or to add emphasis.

The following words are used as indicated throughout the manual:

Shall: understood to be mandatory.

Should: understood to be advisory.

May: understood to be permissive.

Will: indicates a future event/condition to occur.

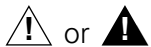

Used in conjunction with signal words (**DANGER, WARNING**, or **CAUTION**) to alert you of potential personal injury hazards, immediately preceding precautionary measures that pertain to subsequent step(s). Obey all safety messages that follow this symbol to avoid possible injury or death. Failure to adhere to safety precautions identified by the safety alert symbol may also void the warranty.

DANGER

- Indicates an imminently hazardous situation which, if not avoided, will result in death or serious injury.

WARNING

- Indicates a potentially hazardous situation which, if not avoided, could result in death or serious injury.

CAUTION

- Indicates a potentially hazardous situation which, if not avoided, may result in minor or moderate injury. Also used to alert against unsafe practices.

CAUTION

- When used without the safety alert symbol, **CAUTION** indicates a potentially hazardous situation which, if not avoided, may result in equipment/property damage, and void the warranty.

NOTE:

- Identifies suggested, recommended, or other noteworthy information.

Specific Safety Precautions

For your safety, please observe the following precautions when operating or servicing your Giles equipment. Read the following important safety information to avoid personal injury and/or damage to the equipment.

DANGER

- Turn off the unit and unplug the power cord before cleaning or performing maintenance.
- **DO NOT** hose down the unit's interior or exterior with water.
- Failure to comply with these **DANGER** notices will result in death or serious injury, equipment/property damage, and void the warranty.

WARNING

- Consult a qualified electrician to ensure that:
 - all electrical specifications and codes are met.
 - circuit breakers and wiring are of sufficient rating and gauge.
- The unit must be properly grounded and all electrical specifications must be met during installation.
- Improper installation, adjustment, alteration, service or maintenance could result in death or serious injury, equipment/property damage, and void the warranty.
- **DO NOT** use or store flammable liquids, or materials producing flammable vapors, in the vicinity of this or any other appliance!
- Failure to comply with **WARNING** notices could result in death or serious injury and equipment/property damage and void the warranty.

WARNING

- Internal ultraviolet radiation source
- Keep protective barrier in place.
- Replace all removable covers or panels after servicing.
- Interlocks are installed to reduce potential for exposure to excessive ultraviolet radiation. **DO NOT** attempt to bypass these interlocks.

CAUTION

- **The unit must be adequately and properly grounded. Improper grounding may result in electrical shock. Always refer to local electrical code to ensure proper grounding of this or any other electrical equipment. Always consult with an electrician or other qualified service person to ensure breakers and wiring are of sufficient rating and gauge for the equipment being operated.**
- Ensure the unit is positioned in a secure, safe location.
- Consult an electrician to ensure all electrical specifications have been met and the unit is properly grounded. The wiring diagram provided with this unit should aid an electrician during installation.

CAUTION

- The electronic components of the Control Panel are impact-sensitive. Exercise care around the Control Panel to maintain proper operation.
- During cleaning of the unit
 - **DO NOT** steam clean.
 - **DO NOT** use products containing chlorine.
 - **DO NOT** use abrasive products, steel wool or scouring pads.
- **DO NOT** modify, alter or add attachments to this equipment!
- Failure to comply with these **CAUTION** notices may result in equipment/property damage and void the warranty.

CAUTION

- The unit must remain in the upright (vertical) position.
- Exercise care when removing the wooden crate from around the unit.
- **DO NOT** operate the unit unless you fully understand the components and their intended function (see Section 3).

NOTE:

- If the crate is damaged upon receipt, immediately inspect the unit and notify the carrier of any damage to the unit.
- To aid the electrician, an electrical wiring diagram is provided with the unit. Refer to the wiring diagram during installation or servicing.
- Comply with all appropriate state and/or local health regulations regarding the cleaning and sanitation of equipment.

NOTE:

- **Consultation with an HVAC specialist may be required for some installations to confirm proper room air exchange and the heat load capabilities of the on site AC system.**
- Exhaust ventilation is recommended for areas in which recirculating hoods are used. We recommend 50 CFM per linear foot of hood space.
- This amount could vary based on local codes and the site specific installation requirements.

Notes:

1. Introduction

Congratulations on the purchase of your new Giles Free Standing Ventless Hood, Model FSH-2 or FSH-2A-99 manufactured by Giles Enterprises, Inc., Montgomery, Alabama (USA), hereafter referred to as "Giles". The Free Standing Ventless Hood is a product of extensive research and testing. Every unit is thoroughly inspected and tested prior to shipment. Proper care and maintenance will ensure years of trouble-free service.

The Giles Ventless Hood System is used in conjunction with various listed cooking appliances to accomplish removal of grease vapors and objectionable odors which may be generated during cooking. The hood system performs this function through the use of what is commonly referred to as an electronic air cleaner (EAC). Electronic air cleaners use an electrical charge to remove contaminants from the air as they pass through the EAC.

To help protect your investment in this equipment, we recommend taking a few moments to familiarize yourself with the installation, cleaning and maintenance procedures contained in this manual. Read these instructions before installation and use. Adherence to these recommended procedures minimizes the potential for costly "down-time" and equipment repairs. Please retain this manual for future reference.

1-01. Construction

All of the unit's exterior parts are constructed of stainless steel.

1-02. Standard Features

Three Stage Filtration -uses three different filters to remove particulate matter from the air.

Extinguishing System -built into the hood to extinguish an accidental fire from the Fryer installed underneath the hood.

1-03. Optional Feature

Ultimate Ventless: Ultra Violet light in conjunction with Giles patented air filtration system improves emission cleaning and odor control as well as keeping the unit free from grease build up.

Interlocking Start System (ILS): In the event of a power interruption, the Hood and the Appliance below the Hood will not restart after power is restored until attended by an operator. ILS is required by some cities and/or states. Please check with your local code officials to see if this system is required.

1-04. Specifications

1-04.01. Overall Dimensions for FSH-2

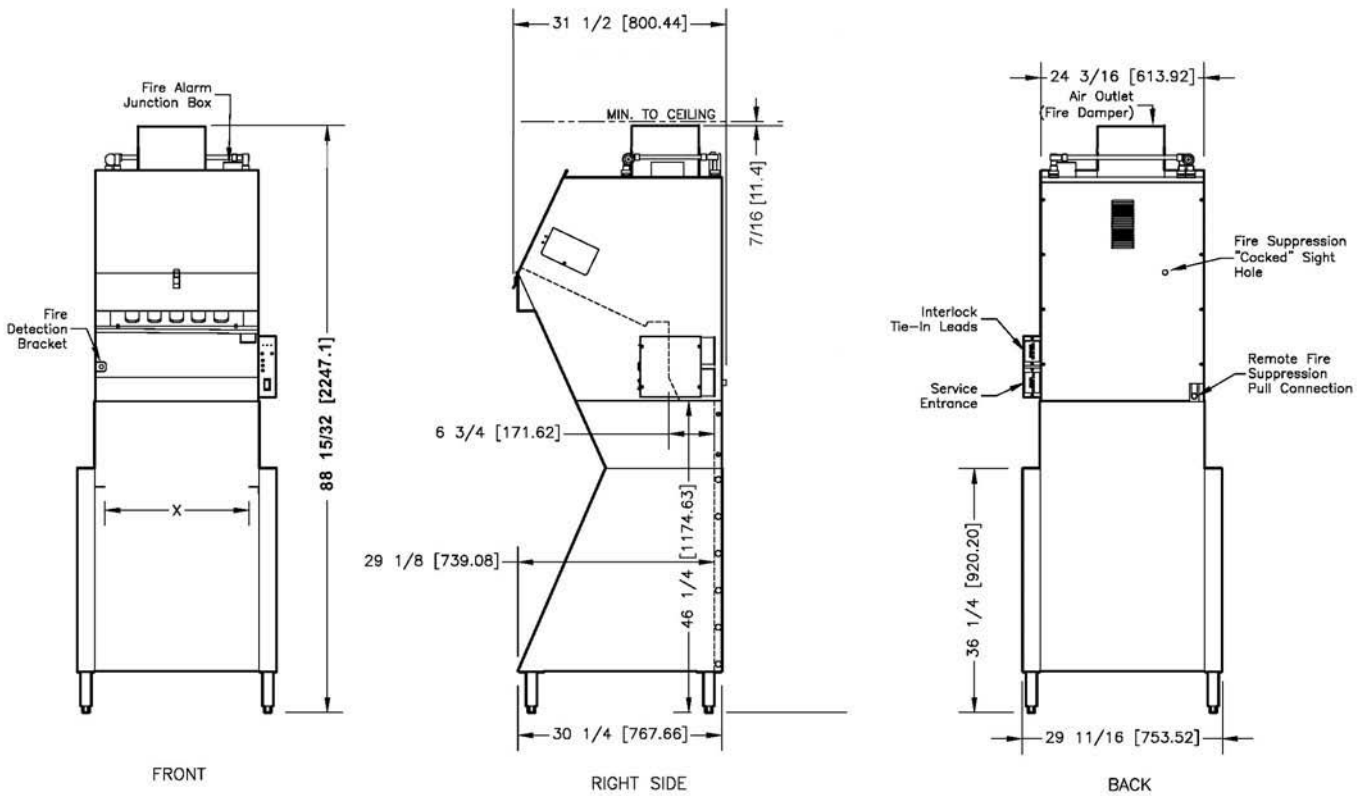

INCHES [MILLIMETERS]

DOCKING OPENING WIDTH "X"		
MODEL (LETTER DESIGNATION FOR OPENING)	IN.	MM
FSH-2 (A)	24	609.6
FSH-2 (B)	20-1/8	511.2
FSH-2 (C)	18-5/8	473.1
FSH-2 (D)	16-1/8	409.6
FSH-2 (E)	15-5/8	396.9
FSH-2 (F)	15-1/8	384.2
FSH-2 (G)	14-1/8	358.8
FSH-2 (H)	10-1/8	257.2

1-04.02. Overall Dimensions for FSH-2A-99

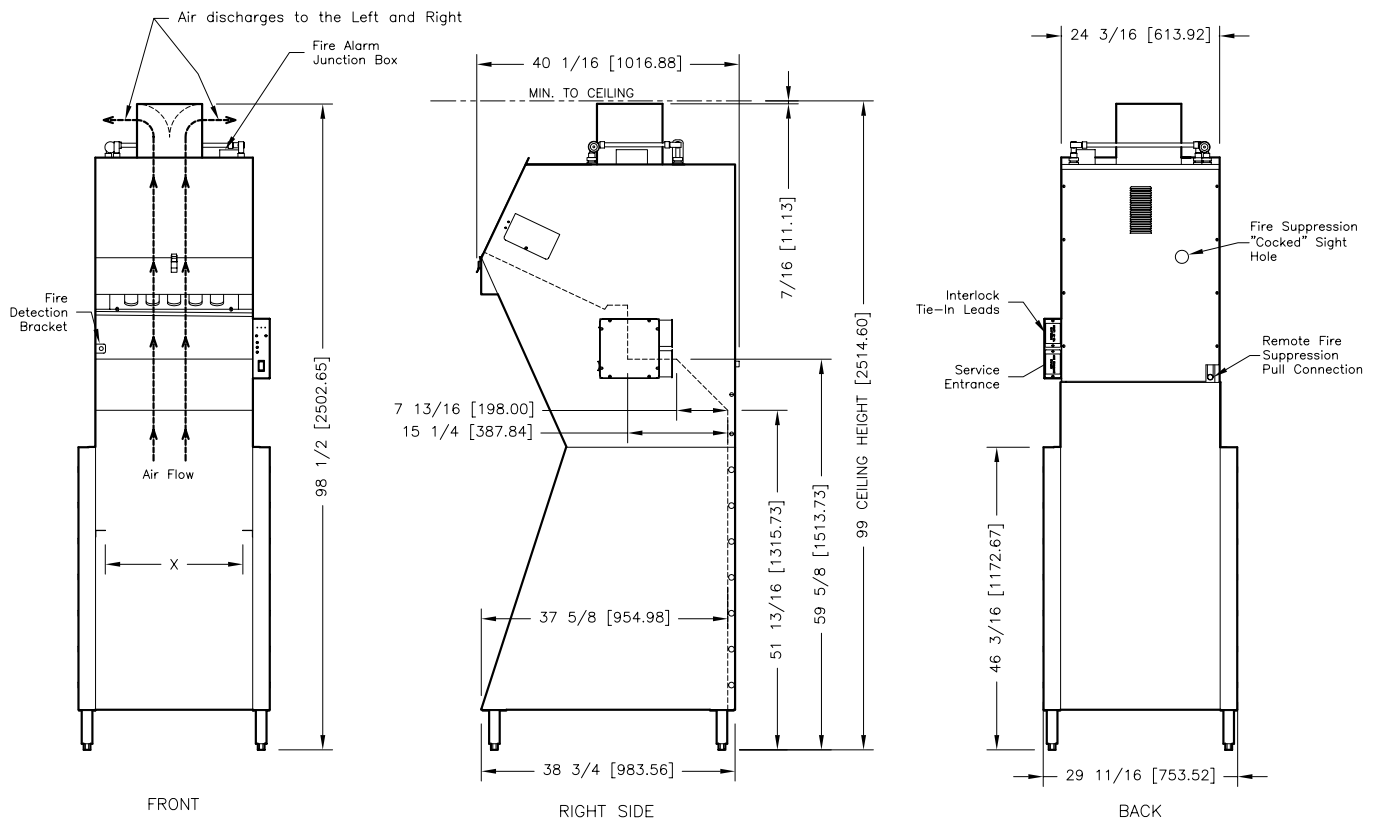

INCHES [MILLIMETERS]

DOCKING OPENING WIDTH "X"		
MODEL (LETTER DESIGNATION FOR OPENING)	IN.	MM
FSH-2-99 (A)	24	609.6
FSH-2-99 (B)	20-1/8	511.2
FSH-2-99 (C)	18-5/8	473.1
FSH-2-99 (D)	16-1/8	409.6
FSH-2-99 (E)	15-5/8	396.9
FSH-2-99 (F)	15-1/8	384.2
FSH-2-99 (G)	14-1/8	358.8
FSH-2-99 (H)	10-1/8	257.2

1-05. Regulatory Listings

UL (US and Canada)
NSF
CE

1-06. Unit Weights

Model	Weights			
	Crated		Uncrated	
	lb	kg	lb	kg
FSH-2	462	146	327	148
FSH-2A-99	535	243	380	173

2. Installation

This section provides a summary of the procedures necessary for proper installation of your unit. To help prevent personal injury or equipment damage, please ensure the following steps are taken.

2-01. Location

NOTE:

- The decibel level of the hood when operating is approximately 65 dB's.

 **CAUTION**

- **DO NOT MODIFY, ALTER OR ADD ATTACHMENTS TO THIS EQUIPMENT**

1. Before unpacking the unit and assembling the unit, using the dimensions and clearances shown in Section 2-04.03. and 2-04.06, determine the location of the unit.
2. Keep the unit and the surrounding area free and clear from combustible materials.
3. Please provide adequate room for servicing and proper operation of the unit. Also, provide adequate ventilation in the operating area where necessary.
4. Before operating, make sure the unit is in a secure position and will not move.

NOTE:

- **Consultation with an HVAC specialist may be required for some installations to confirm proper room air exchange and the heat load capabilities of the on site AC system.**
- Exhaust ventilation is recommended for areas in which recirculating hoods are used. We recommend 50 CFM per linear foot of hood space.
- This amount could vary based on local codes and the site specific installation requirements.

2-02. Unpacking

The unit will arrive enclosed by a wooden crate. The Hood is secured to a wooden platform by means of high-tensile strength strapping and wrapped with stretch-wrap.

NOTE:

- **If the crate is damaged, immediately inspect the unit and notify the carrier of any damage to the unit.**

⚠ CAUTION

- **Exercise care when lifting or moving the unit.**
- **Exercise care when removing the wooden crating from around the unit.**
- **Failure to comply with these CAUTION notices may result in minor or moderate injury, equipment/property damage, and void the warranty.**

1. Carefully cut and remove the plastic shipping wrap and the strapping.
2. Using appropriate tools, carefully remove the wooden crating from around the unit.
3. Carefully remove the unit from the shipping platform. The FSH-2 or FSH-2A-99 is extremely heavy, see Section 1-03.04. for unit weights. Great care should be taken when lifting or moving the unit to prevent personal injury or equipment damage.

2-03. Electrical Requirements

⚠ WARNING

- Consult a qualified electrician to ensure all electrical specifications have been met.
- **The unit must be adequately and properly grounded. Improper grounding may result in electrical shock. Always refer to local electrical code to ensure proper grounding of this or any other electrical equipment. Always consult with an electrician or other qualified service person to ensure breakers and wiring are of sufficient rating and gauge for the equipment being powered.**
- Improper installation, adjustment, alteration, service or maintenance could result in death or serious injury, equipment or property damage, and void the warranty.

Hood Electrical Requirements (Hood Only)

Unit	Voltage	Hz	Phase	Amps	Breaker
FSH-2	208-240	60	1	3	10
FSH-2A-99	208-240	60	1	3	10

2-03.01. Electrical Connections (Overview)

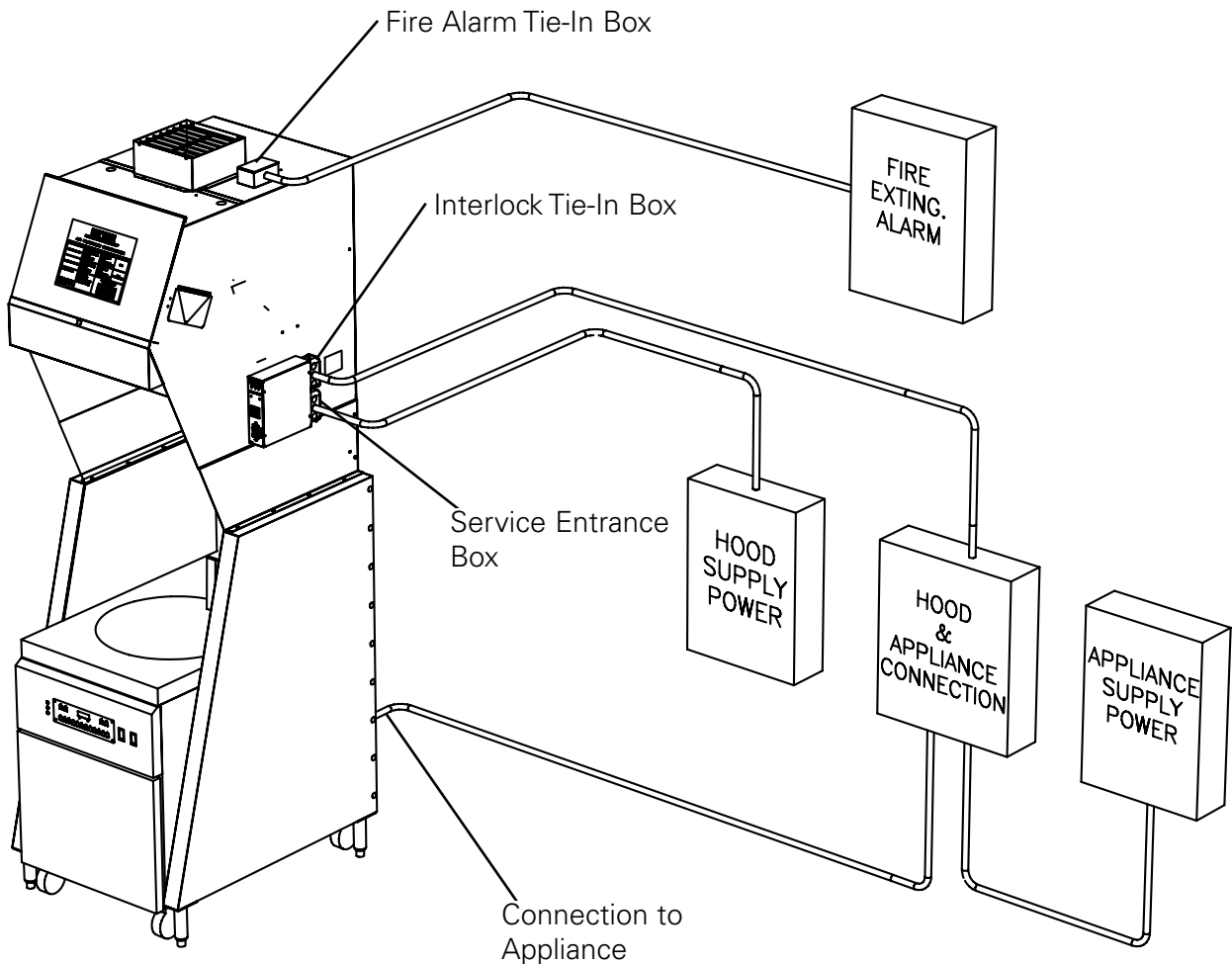

2-03.02. Hood Power Connection

Connect Hood Power:

1. Install appropriate Circuit Breakers in Hood Supply Power Box (Main Breaker Box). See Section 2-03. for required Circuit Breakers.
2. Remove Cover on Service Entrance Box and run appropriate size conduit and wire from the Service Entrance Box to the Hood Supply Power box (Main Breaker Box). Allow enough conduit and wire so the unit can be accessed for cleaning and servicing.
3. Make all appropriate connections.
4. Reinstall Service Entrance Box Cover.

2-03.03. Hood and Appliance Interlock Connection

This interlock circuit will disable power to the Appliance installed under the Hood if any of the following occurs:

- Any Filter becomes excessively dirty, not allowing proper air flow through the Hood.
- Any Filter is missing or not installed correctly
- The Fire Extinguisher System is activated.

Interlock Hood to Appliance:

1. Remove Cover on Interlock Tie-In Box and run appropriate size conduit and wire from the Interlock Tie-In Box to a Hood and Appliance Connection Box (Supplied by Customer). Allow enough conduit and wire so the Hood can be accessed for cleaning and servicing.
2. Make appropriate connections. See Diagram below.
3. Reinstall Interlock Tie-In Box Cover.

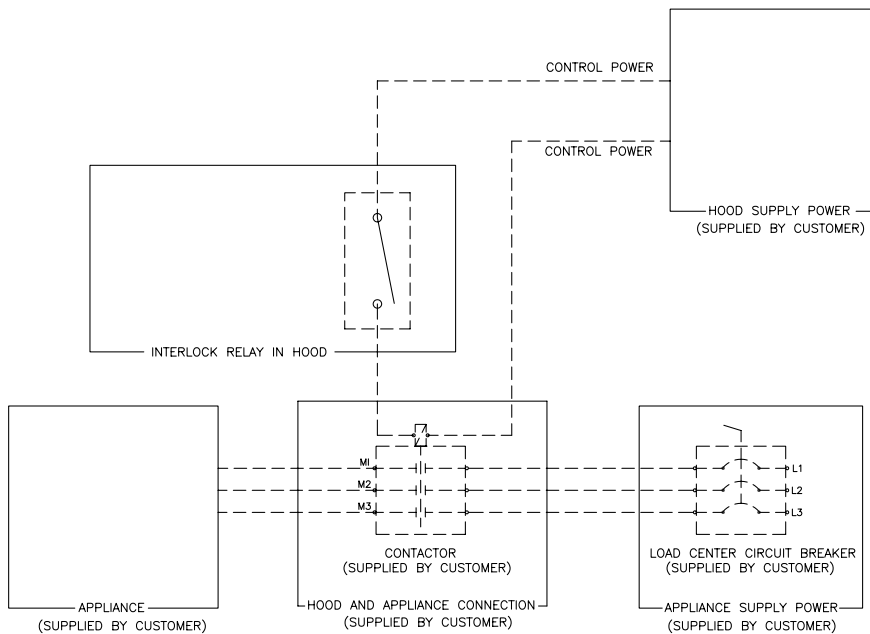

NOTE:

- **If not using the ILS option, the Hood will continue to run and the Appliance will turn off when:**
 - Any Filter becomes excessively dirty, not allowing proper air flow through the Hood.
 - Any Filter is missing or not installed correctly.
 - The Fire Extinguisher System is activated.
- **If using the ILS option, the Hood and Appliance will turn off when:**
 - Any Filter becomes excessively dirty, not allowing proper air flow through the Hood.
 - Any Filter is missing or not installed correctly.
 - The Fire Extinguisher System is activated.

2-03.04. Fire Alarm Connection

This connection will send a signal the Facility Fire Alarm System in the event that the Hood Fire Extinguisher System is activated.

Fire Alarm Connection:

1. Remove Cover on Fire Alarm Tie-In Box and run appropriate size conduit and wire from the Box to the Facility Fire Alarm System. Allow enough conduit and wire so the Hood can be accessed for cleaning and servicing.
2. Make appropriate connections.
3. Reinstall Fire Alarm Tie-In Box Cover.

2-04. Limitations and Clearances

This section describes various limitations for appliances that can be placed underneath the hoods. ONLY electrically heated appliances, which meet these limitations and clearances are approved for use under these hoods. Gas appliances or appliances other than the types stated are not approved.

2-04.01. Fryer Limitations

WARNING

- **The Hoods are design for Electric Fryers Only!!! DO NOT USE ANY GAS APPLIANCES UNDER THE FSH-2 or FSH-2A-99!!**

Hood	Max. kW Input	Max. Shortening Capacity (lbs)	Max Cooking Surface (per Fryer)
FSH-2	20	110	380 Sq. In.
FSH-2A-99	20	110	380 Sq. In.

2-04.02. Fryer Clearances for FSH-2

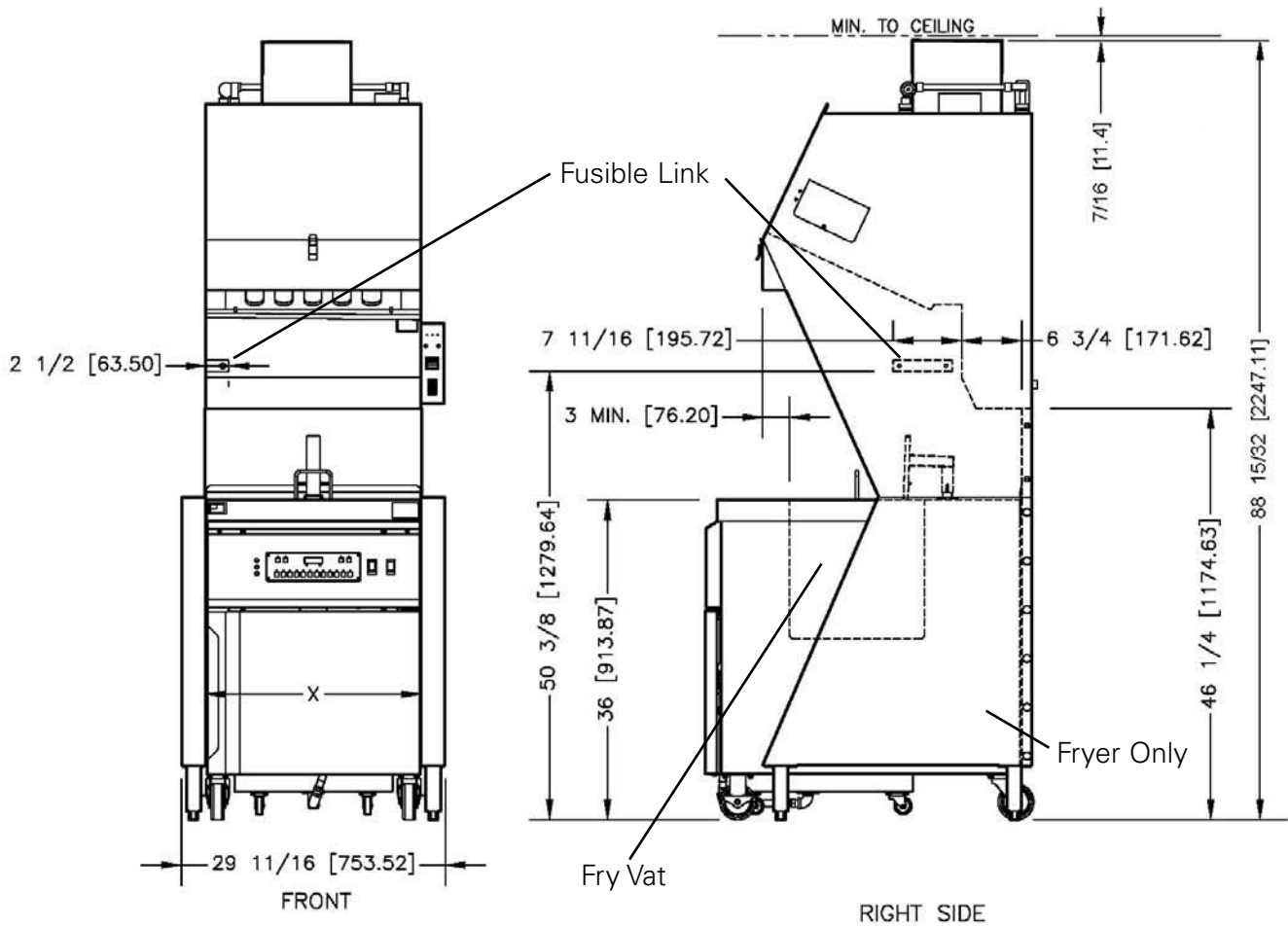

INCHES [MILLIMETERS]

DOCKING OPENING WIDTH "X"		
MODEL (LETTER DESIGNATION FOR OPENING)	INCHES	MILLIMETERS
FSH-2 (A)	24	609.6
FSH-2 (B)	20-1/8	511.2
FSH-2 (C)	18-5/8	473.1
FSH-2 (D)	16-1/8	409.6
FSH-2 (E)	15-5/8	396.9
FSH-2 (F)	15-1/8	384.2
FSH-2 (G)	14-1/8	358.8
FSH-2 (H)	10-1/8	257.2

2-04.03. Fryer Clearances for FSH-2A-99

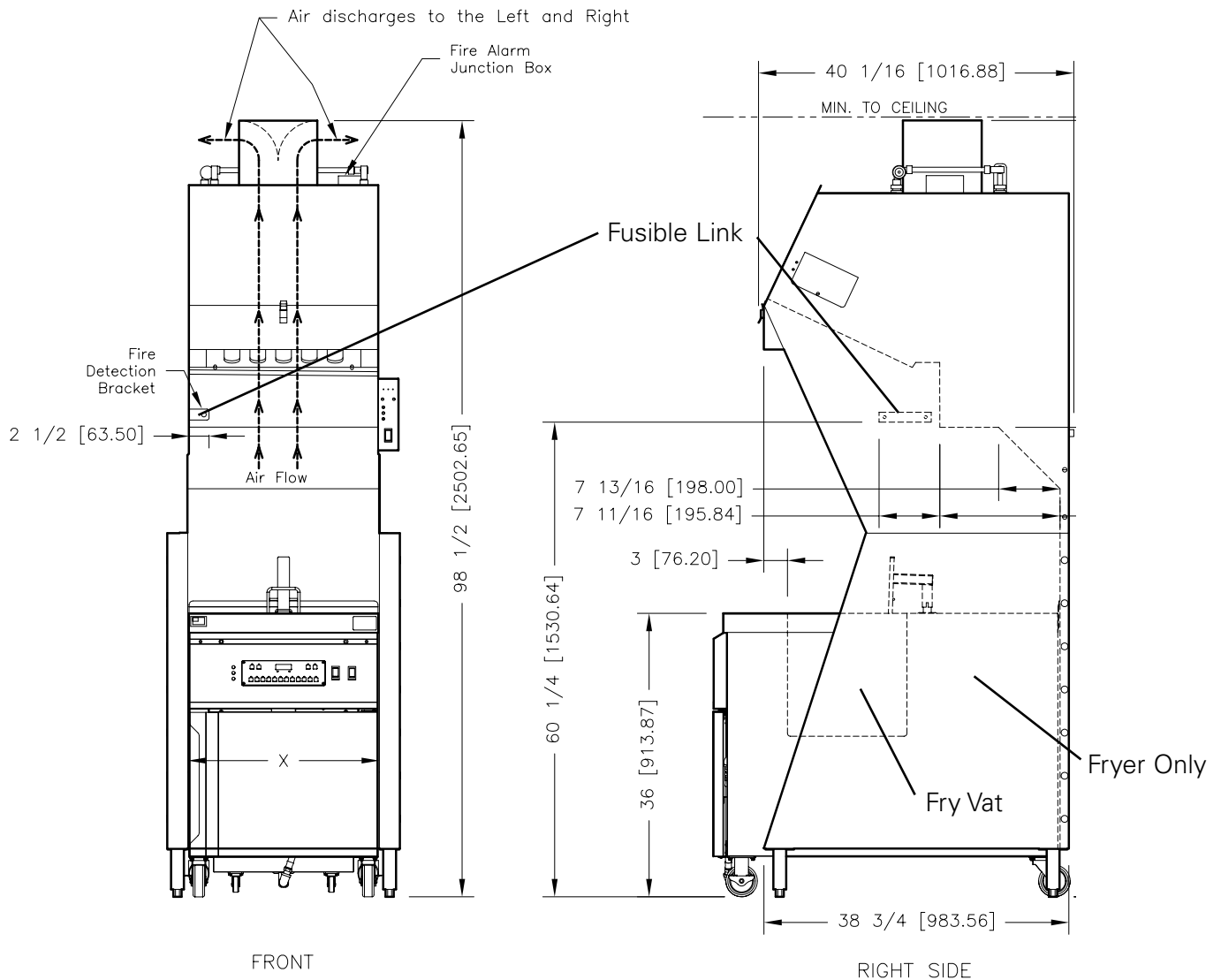

INCHES [MILLIMETERS]

DOCKING OPENING WIDTH "X"		
MODEL (LETTER DESIGNATION FOR OPENING)	INCHES	MILLIMETERS
FSH-2A-99 (A)	24	609.6
FSH-2A-99 (B)	20-1/8	511.2
FSH-2A-99 (C)	18-5/8	473.1
FSH-2A-99 (D)	16-1/8	409.6
FSH-2A-99 (E)	15-5/8	396.9
FSH-2A-99 (F)	15-1/8	384.2
FSH-2A-99 (G)	14-1/8	358.8
FSH-2A-99 (H)	10-1/8	257.2

2-05. Fire Suppression System

The fire suppression system used in the Giles Ventless Hood is an ANSUL® R-102 Restaurant Fire Suppression System (Standard UL 710B Listed). **Final installation, charging and certification of the system must be performed by an authorized Ansul distributor in accordance with the system's listing.**

The fire suppression system is designed and UL-listed to provide fire protection for cooking appliances such as fryers. It automatically protects 24 hours per day. The system includes piping, nozzles (appliance & plenum), release mechanism, fusible link brackets, conduit for routing the fusible link cable and 1.5 Gal stainless steel tank.

2-05.01. Fusible Links and Gas Cartridge Location

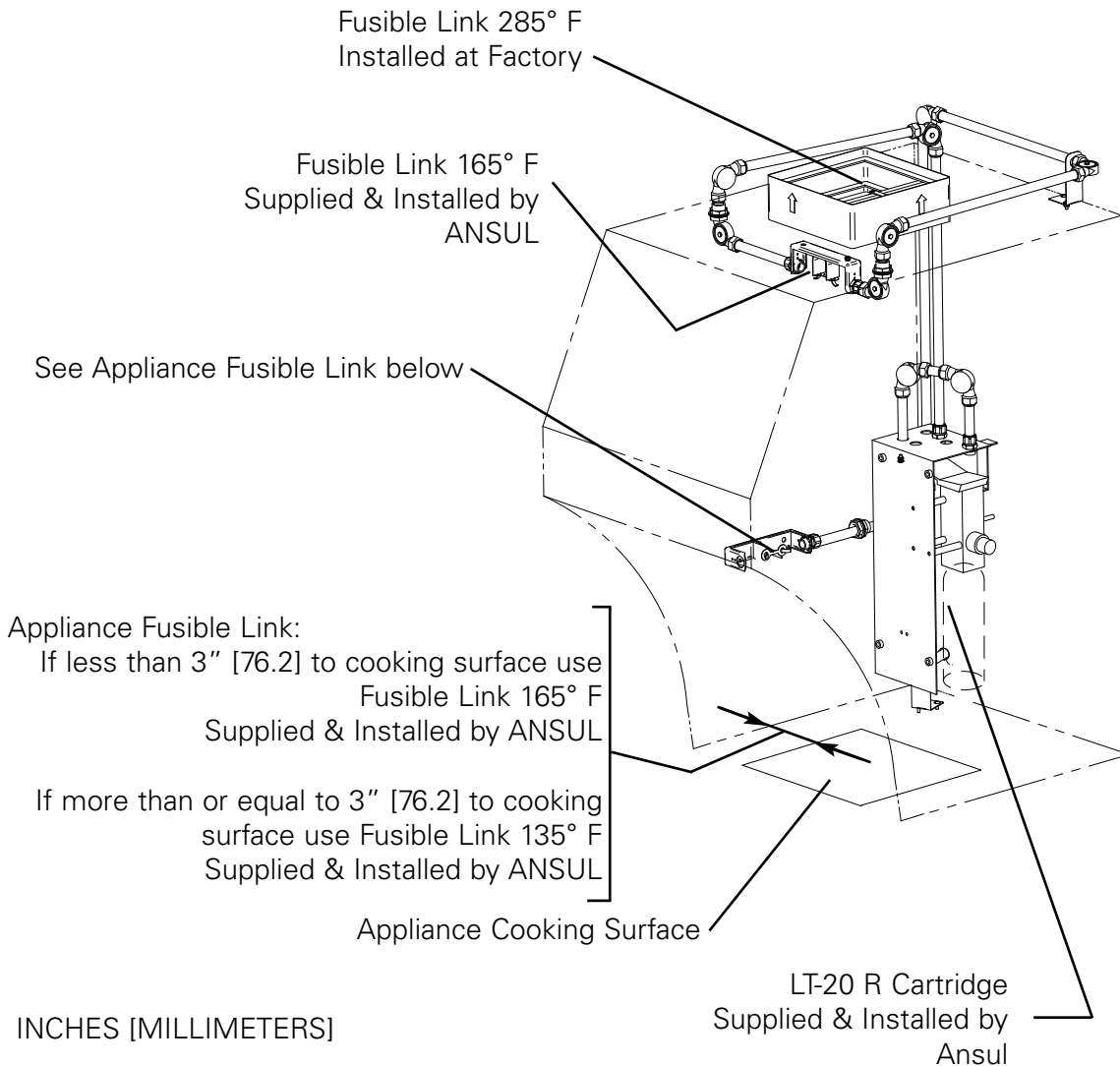

2-05.02. Fire Extinguishing Nozzles and Tank Location

All nozzles have been factory installed and aligned in the proper operating position. **DO NOT MOVE OR ADJUST.**

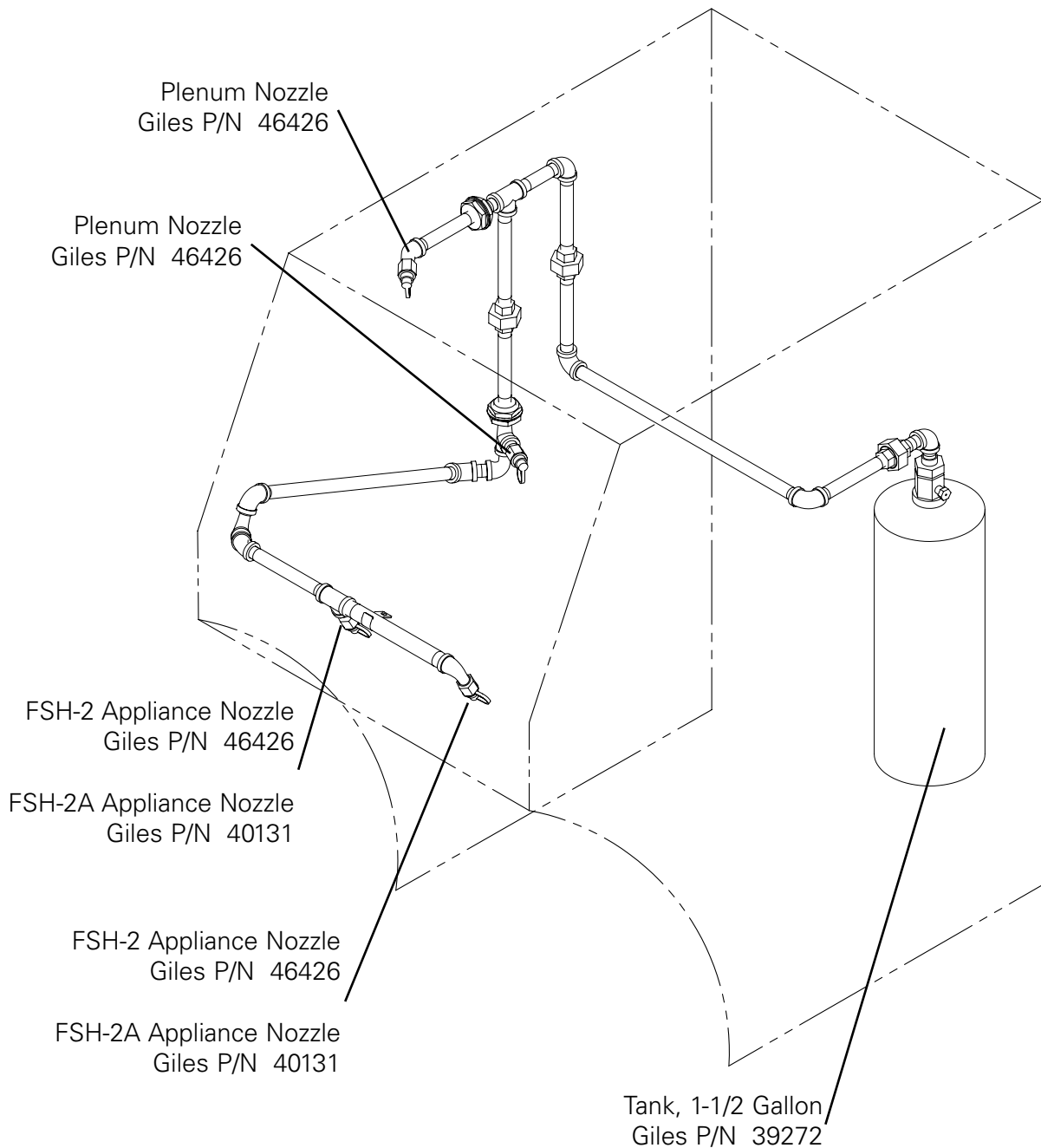

2-05.03. Manual Pull Diagram

This Hood requires use of the ANSUL® R-102 Standard for a Manual Activation System. The Manual Pull Station must be mounted on a nearby wall near the path of egress and connected to the Hood. The Manual Activation System is used to activate the Fire Extinguisher System from a remote location. It is to be supplied and installed by the Ansul agent.

The following illustration is a typical Manual Pull installation. Using this basic configuration the Hood may be moved from the wall for Cleaning and Servicing without removing the Manual Pull from the wall.

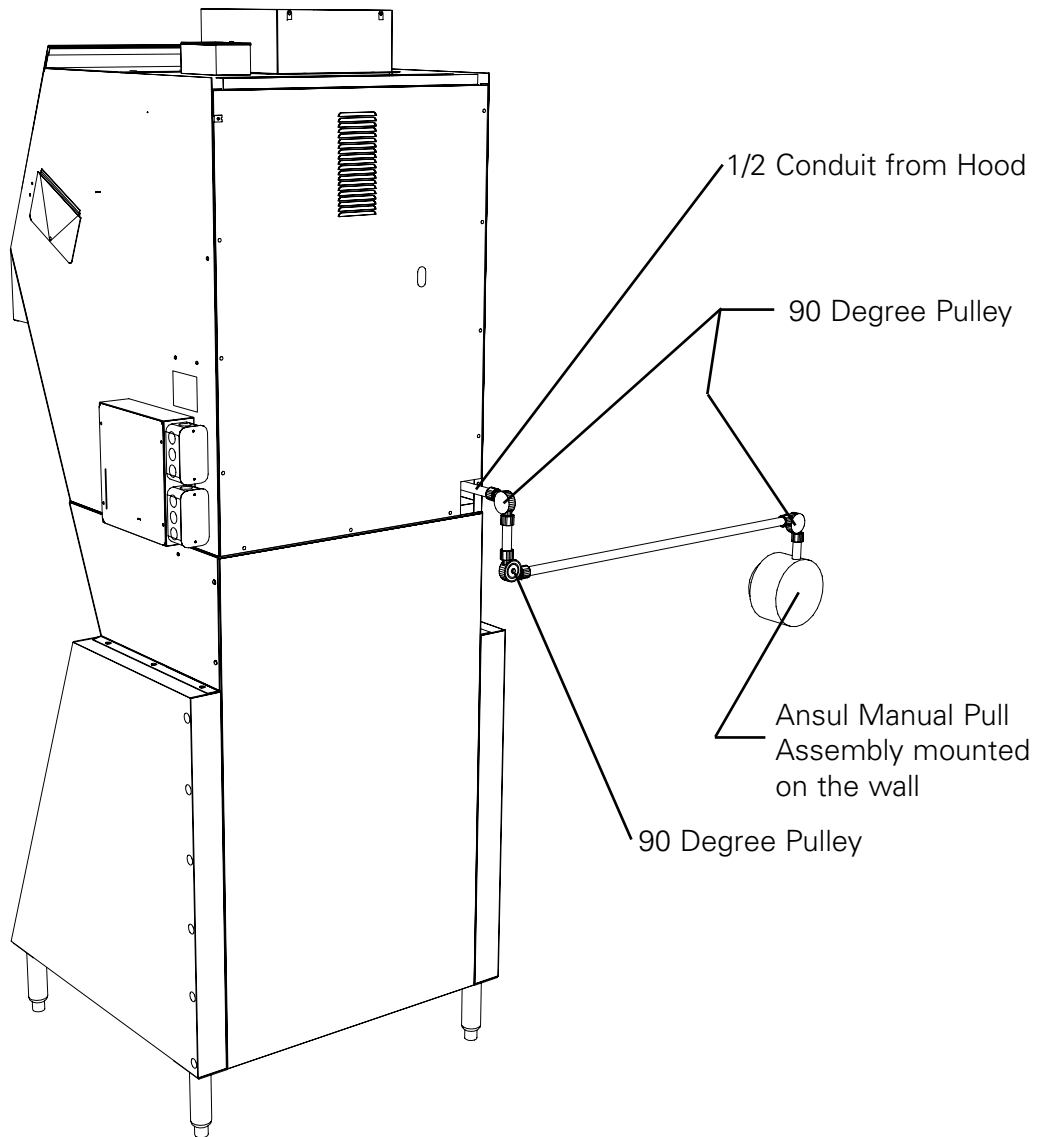

2-06. Restraining Device

Any Fryer placed under this Hood must be secured so that it can not move from under the Hood. The following depicts an example of a suitable restraining device. The restraining device must be appropriate for the appliance being used and will vary depending on the make and model of Fryer. **Restraining device is not supplied with the hood.**

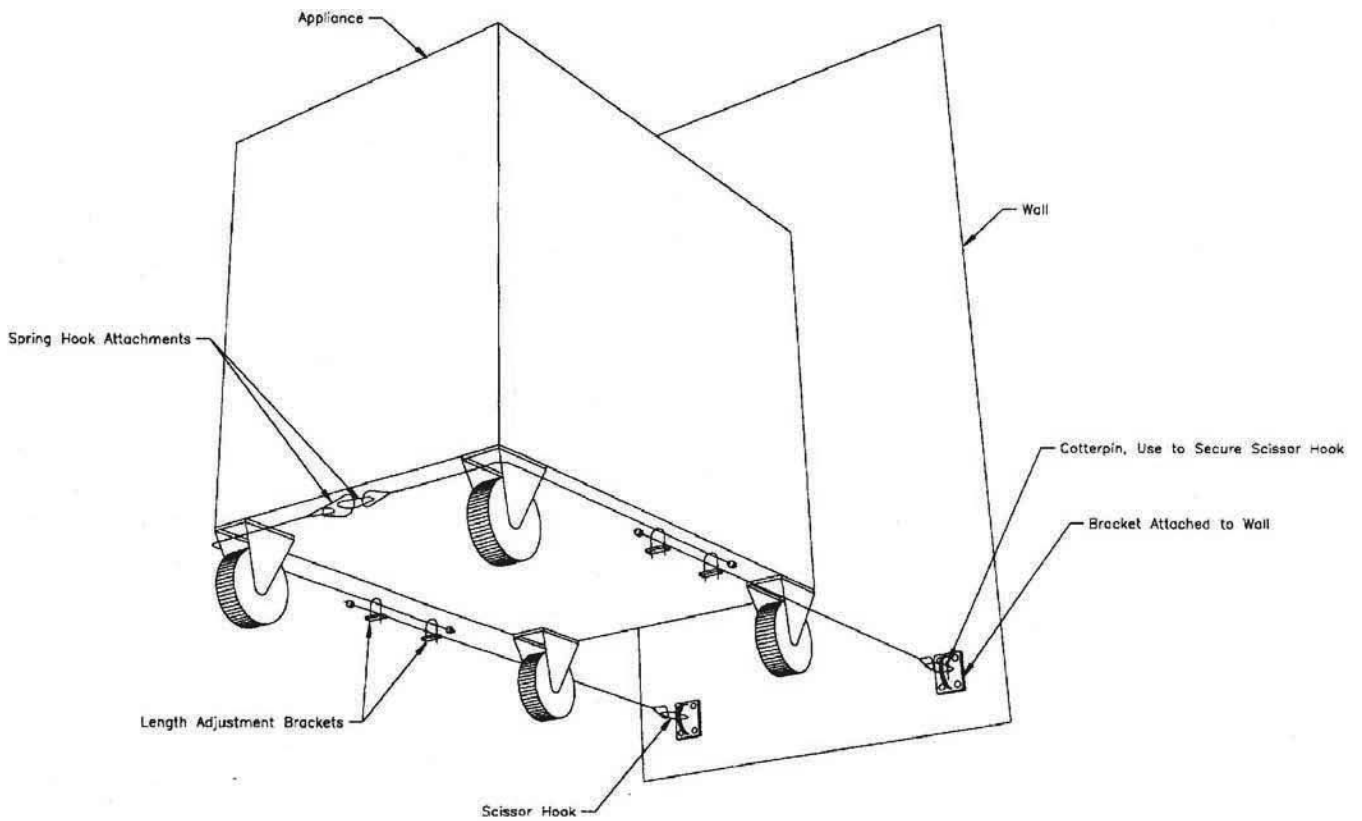

Note: Be sure to maintain minimum and maximum clearances (see Section 2-04.02 or 2-04.03 after the Restraining Device is installed.



3. Overview

The following section provides a brief overview of the components, functions, and accessories of the Free Standing Hood, Model FSH-2, FSH-2A-99. Please review this section carefully before proceeding further.

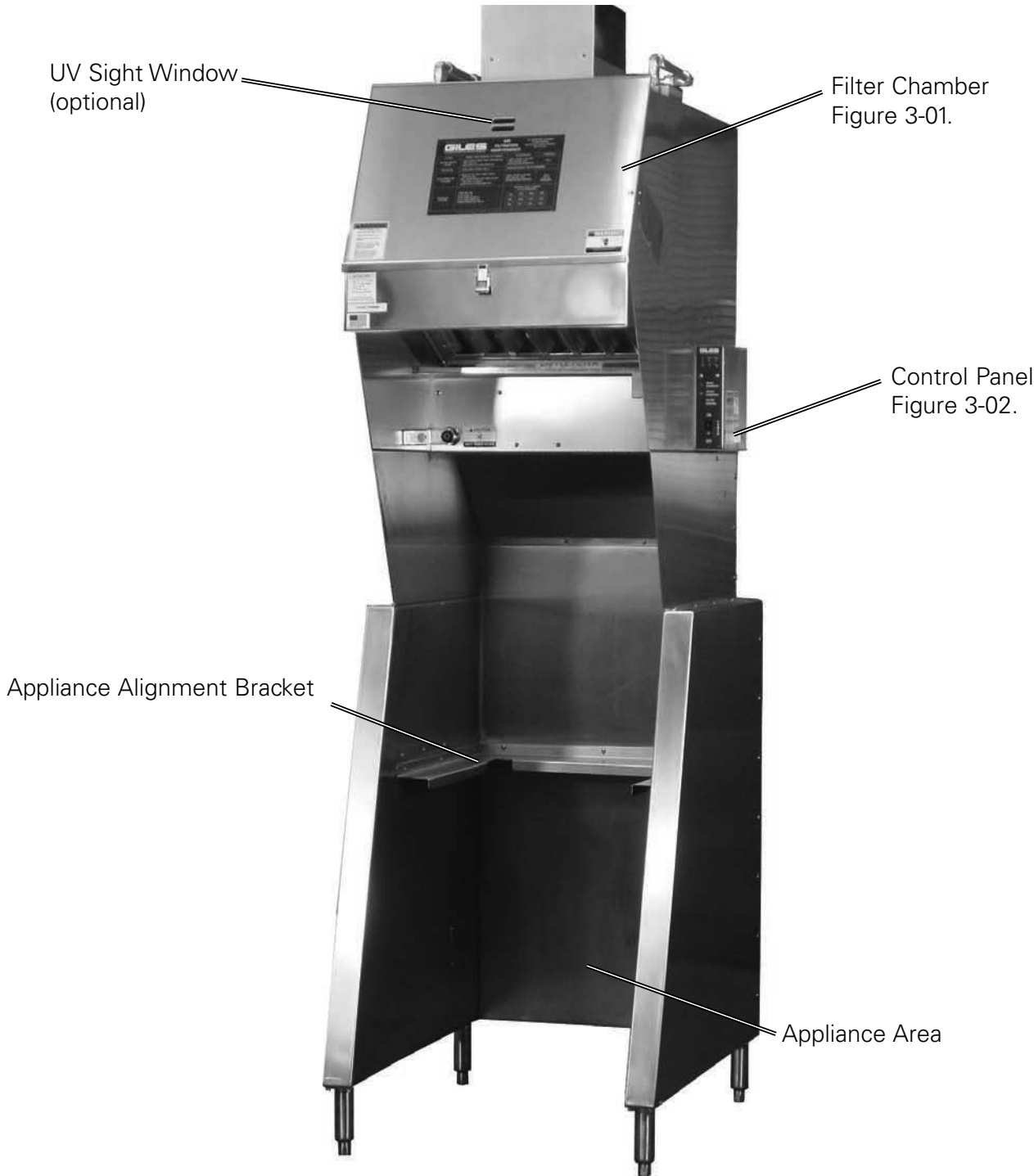

3-01. Filter Chamber



* Not Shown

3-01. Filter Chamber

Item	Description	Function
*1	Filter Acces Cover	Provides access for the Electronic Air Cleaner (EAC), Charcoal Filter and (optional) UV Lamp. This cover must be in place and latched for the unit to operate. <i>Ultra Violet Panel has sight windows.</i>
2	Ultraviolet Lamp (optional)	Sanitizes discharge air and helps with controlling unwanted cooking aromas. This lamp should be cleaned monthly and replaced annually. DO NOT touch Lamp with bare hands
3	Charcoal Filter	This Filter helps to remove unwanted aromas generated during cooking. It should be replaced monthly. NEVER attempt to clean the Charcoal Filter. Keeping a spare filter (Giles #30248) for quick exchange when needed can avoid down-time! DO NOT remove the Charcoal Filter while the Hood or the Fryer is operating to prevent contact with electrical parts and avoid electrical shock.
4	EAC Filter	The EAC Filter is an electronic cell which electrostatically removes grease-laden vapor and smoke emissions generated by the fryer during cooking. Power must be turned OFF to the Hood and Fryer before removing the EAC for cleaning. The EAC should be cleaned daily for best performance. DO NOT remove the EAC Filter while the Hood or the Fryer is operating to prevent contact with electrical parts and avoid electrical shock.
5	Baffle Filter	The Baffle Filter is the first stage of the grease-laden vapor removal and air-cleaning system. It is easily removed for daily cleaning. DO NOT remove the Baffle Filter while the Hood or the Fryer is operating to prevent contact with electrical parts and avoid electrical shock.
6	Grease Drip Cup	Captures and contains the grease condensate generated at the Baffle Filter. It should be cleaned daily or as needed.
7	Grease Drip Cup Safety Pin	Secures the Grease Drip Cup in place and to prevent the cup from unintentionally falling from the holding bracket.
8	Discharge Air Diverter Stack	Diverts hood exhaust discharge air to the sides and rear. Allows for operation of the unit in spaces with lower ceiling heights.
9	Appliance Fusible Link	Used to detect a fire in the appliance. Be careful not to hit or bump this link. Doing so may inadvertently cause the Fire Extinguisher System to activate.



* Not Shown



3-02. Control Panel



3-02. Control Panel

Item	Description	Function
1	ON Indicator (EAC Status L.E.D.)	Indicates that the Electronic Air Cleaner (EAC) is powered. The EAC is operating normally when this is the only light illuminated.
2	WASH Indicator (EAC Status L.E.D.)	Indicates that the EAC has become excessively dirty. Do not rely upon this light as a signal for routine cleaning. The EAC must be cleaned daily to maintain peak performance. Failure to do so will significantly decrease the life of the charcoal filter.
3	CHECK Indicator (EAC Status L.E.D.)	Indicates that the EAC cell has stopped functioning and is no longer cleaning the air. The EAC cell must be cleaned, repaired or replaced.
4	Hood Powered Indicator Light	Indicates the Hood is powered and running.
5	Fryer Powered Indicator Light	Indicates power is being supplied to the Appliance under the hood and it can be operated.
6	Filter Missing Indicator Light	Used to indicate the Baffle Filter or Charcoal Filter is either missing or not properly installed.
7	Power Switch	Used to turn Hood power on or off.
*8	"Push to Start" Button	<p>Used with ILS (Interlocking Start) units only. After the Power Switch is placed in the ON position, push and hold the "PUSH & HOLD TO START" Button for 5 seconds to start the blower. The button must be pressed and held any time power is interrupted in order to restart the Hood.</p> <p>This option is required by some jurisdictions. Please contact local code officials to see if this is required in your locale.</p>

3-03. Accessories (Included)		
Part	Description/Part Number	Function
	<p>Baffle Filter P/N 42300</p>	<p>Removes grease-laden vapor contaminants from the air</p>
	<p>EAC Filter P/N 20520</p>	<p>Removes smoke and fine grease-laden contaminants from the air stream.</p>
	<p>Charcoal Filter P/N 30248</p>	<p>Helps to remove unwanted cooking aromas from the air stream.</p>

3-03. Accessories (Included)		
Part	Description/Part Number	Function
	EAC Soak Tank P/N 39327	Container for holding degreasing solution used to clean EAC cell daily.
Part	Description/Part Number	Function
	UV Lamp P/N 90226	Sanitizes discharge air and the hood's plenum area. Helps with controlling unwanted aromas.



Notes:

4. Operation

This section describes operation of the Hood and filter maintenance procedures.

4-01. Hood Operation

This section describes how to start the Ventless Hood. Ensure all Filters and UV Lamp, if equipped, are in place and correctly installed before operating the unit.

- Place Power Switch in the **ON** **1** position, (if ILS, press and hold the "Push & Hold to Start" **2** Button for 5 seconds), the following will occur:

3 - illuminates, indicating the EAC cell is **ON** and cleaning the air.

4 - illuminates, indicating the Hood is powered.

5 - illuminates, indicating power is supplied to the Appliance underneath the Hood.

6 - if equipped, sight window illuminates indicating UV is operating

- The Appliance underneath the Hood may now be turned on and used.

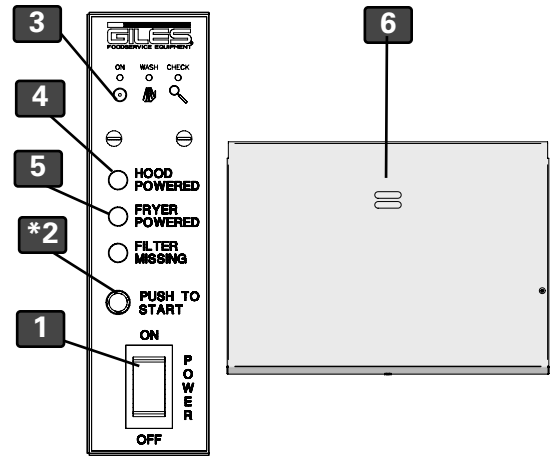

* -ILS only

4-02. Hood Filters and Filter Maintenance

This section describes each Filter and the required maintenance.

4-02.01. Hood Filter Table

Filter	When to clean or replace	How to remove	How to clean	How to install
Baffle Filter	Clean daily	Section 4-02.06	Section 4-02.07	Section 4-02.08
EAC Cell	Clean daily	Section 4-02.08	Section 4-02.11	Section 4-02.09
Charcoal Filter	Replace every 30 days, P/N 30248	Section 4-02.12.	Never clean, replace only Section 4-02.15	Section 4-02.13.
Ultraviolet Lamp	Clean every 30 days Replace annually	Section 4-02.14	Section 4-02.16	Section 4-02.15

4-02.02. Baffle Filter Removal

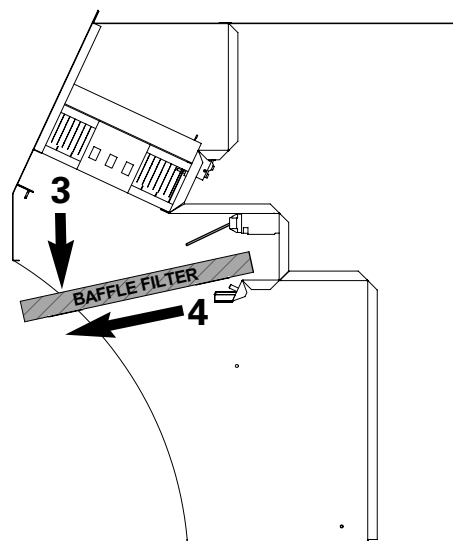
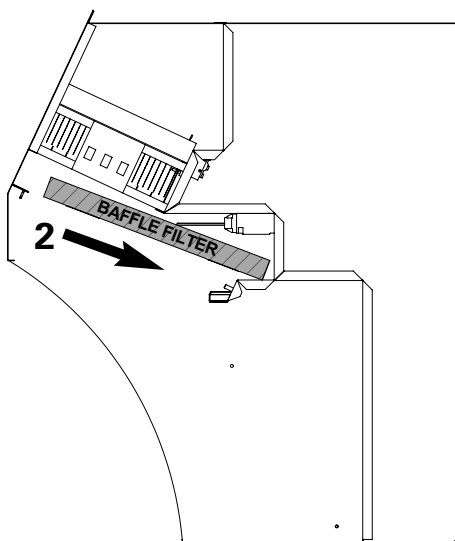
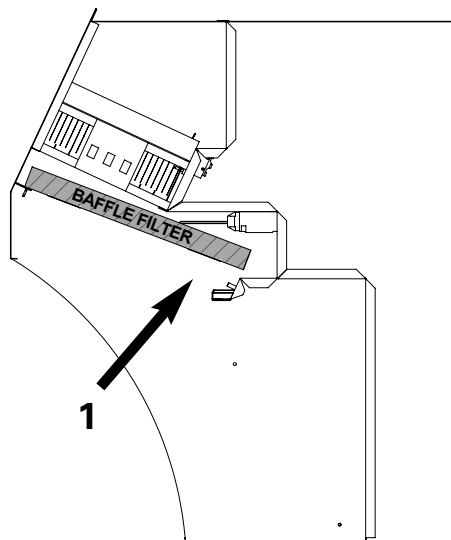
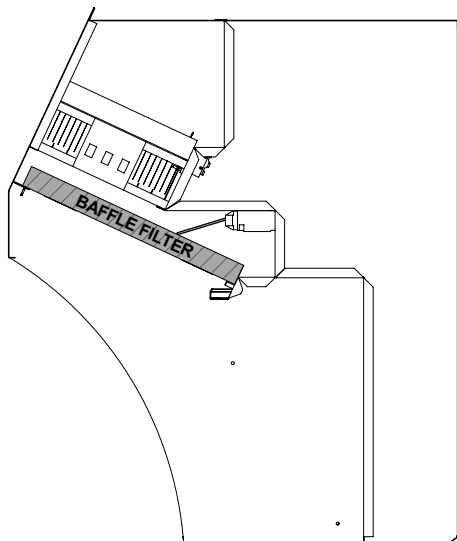

4-02.03. Baffle Filter Installation

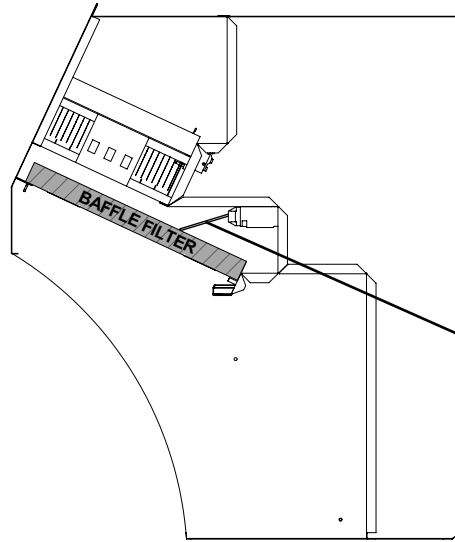
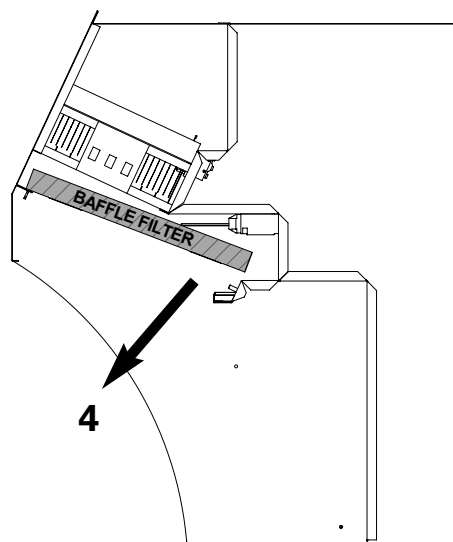
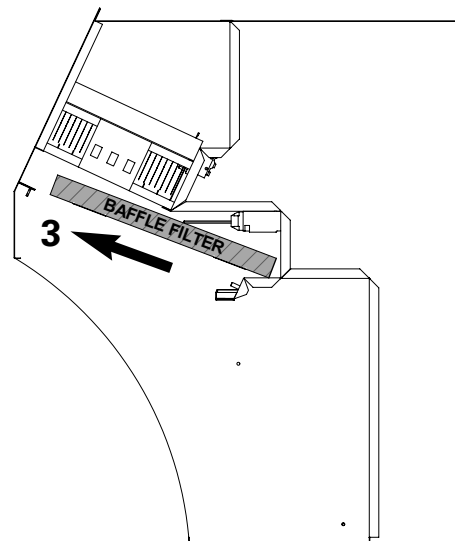
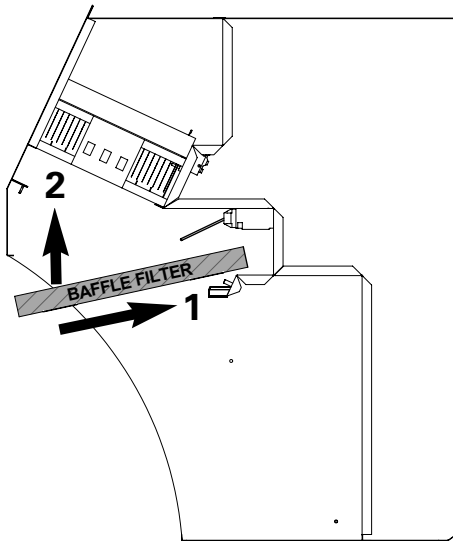

Switch arm must be actuated by the Baffle Filter as shown

4-02.04. Baffle Filter Missing

If the Baffle Filter is either missing or not properly installed, the Filter Missing Light **1** will illuminate and power to the under-hood appliance is disabled until the condition is corrected. See Section 7-02.03 Baffle Filter Installation.

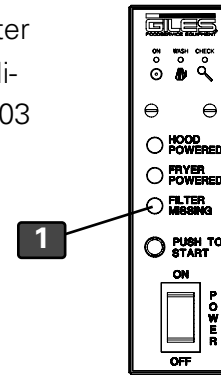

4-02.05. Baffle Filter Cleaning Procedure

The Baffle Filter should be cleaned daily. Place the Baffle Filter in a sink and clean with a mild degreaser. Rinse and dry thoroughly, then reinstall in the unit. The Baffle Filter may be washed in the dishwasher.

Never place a wet filter into the unit!

4-02.06. EAC Filter Removal

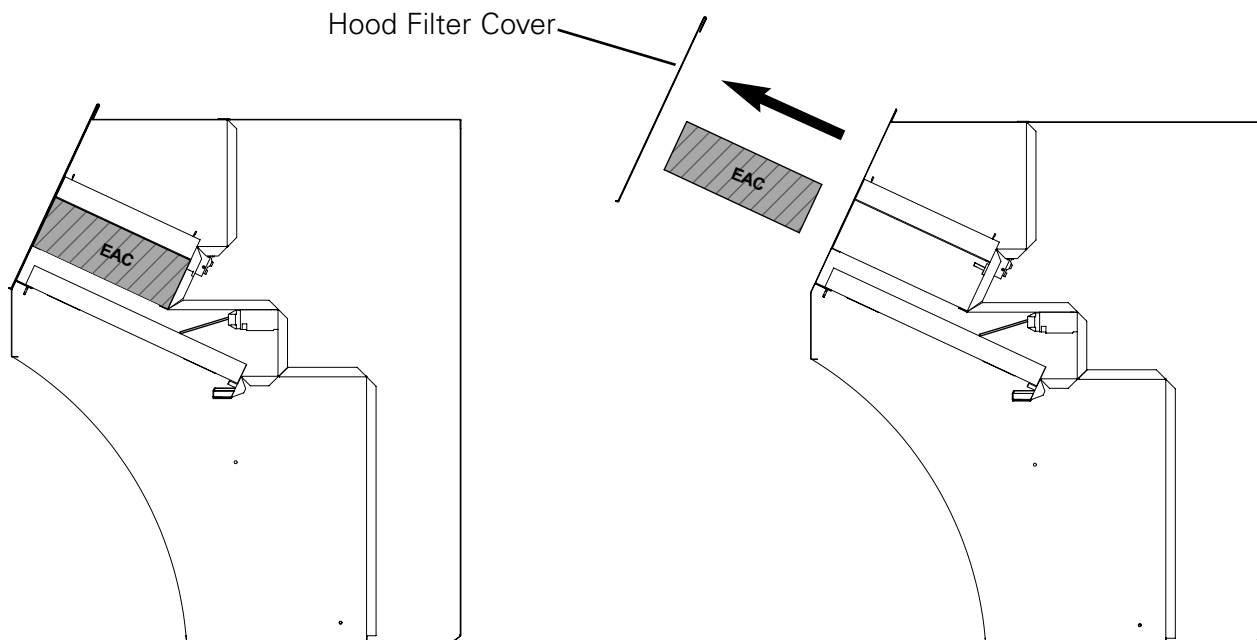

4-02.07. EAC Filter Installation

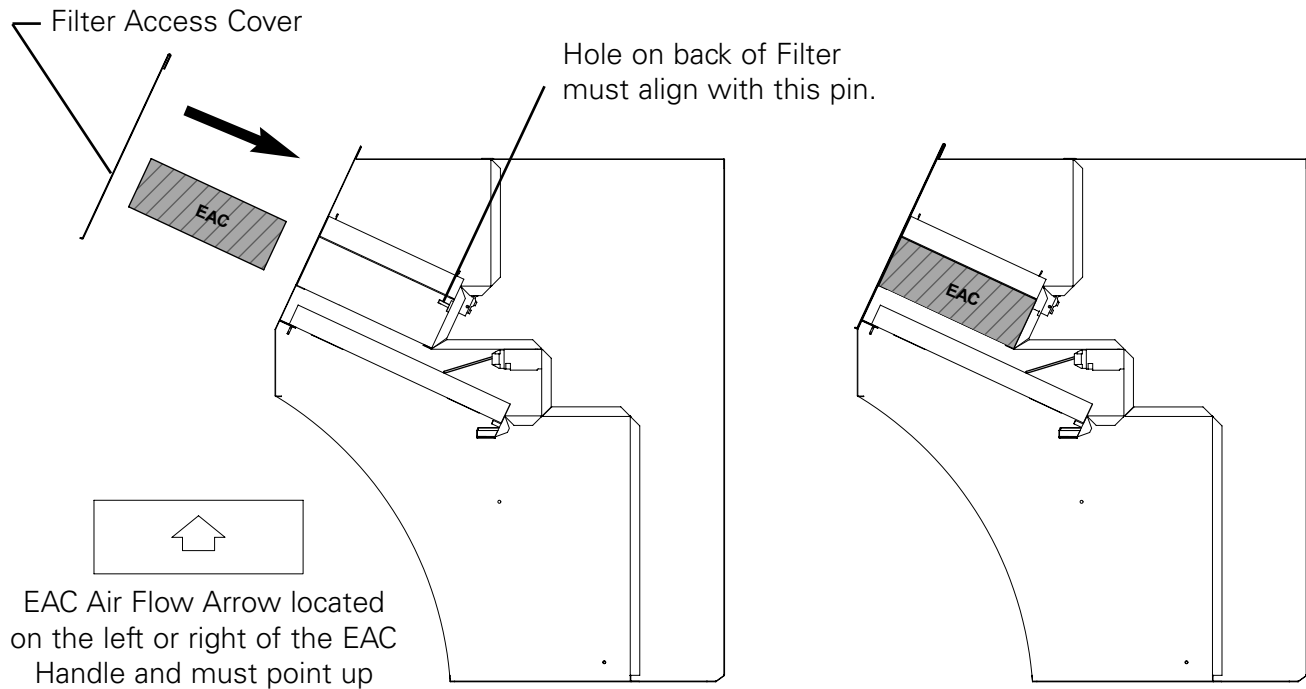

4-02.08. EAC Filter Status

The three L.E.D. indicator lights on the Control Panel display the status of the EAC Cell.

- 1 ON** The EAC Filter is in place and powered.
- 2 WASH** The EAC Filter is becoming excessively dirty and must be cleaned. If this light is **ON** for more then 2 minutes, an intermittent alarm will sound and power to the Fryer underneath the Hood will be disabled.
- 3 CHECK** The EAC Filter is not operating, either the filter is not making proper connection to its power supply or it is damaged. If this light is **ON** or more then 2 minutes, an intermittent alarm will sound and power to the Fryer underneath the Hood will be disabled.

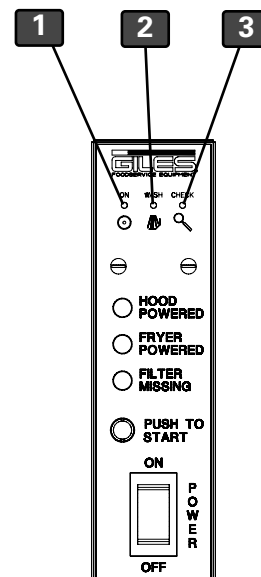

4-02.09. EAC Filter Cleaning

CAUTION

- Do not bend the fins or break the ionizer wires on the EAC cell as this will prevent proper function and potentially void the warranty.

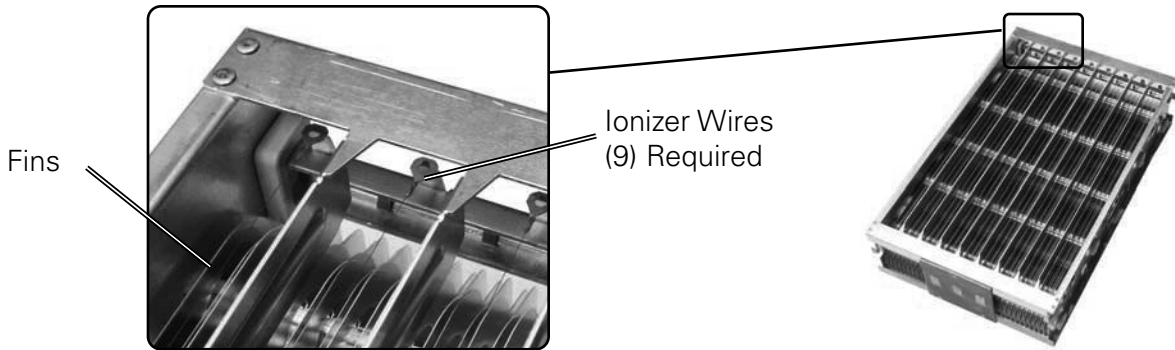

1. Add 1/2 gal. of a mild degreaser, such as **Simple Green** or **Clear Magic**, to the provided Soak Tank **1** ... add water to the fill line marked by X's on the inside of the tank back and mix thoroughly.
2. Grasp the cell's contact plate **2** and carefully lower the EAC **3** into the mixed degreasing solution.
3. Allow the EAC to soak for approx. 30 minutes. After that time, grasp the cell by the contact plate **2**, lift and agitate the cell up and down in the solution several times to dislodge grease residue.
4. Carefully remove the EAC from the tank and rinse thoroughly in a sink using hot water spray.
5. Stand cell on end with contact plate up and allow to air dry overnight.
6. Inspect cell for broken wires or bent fins. Any broken wires need to be replaced promptly. Bent fins may be gently straightened by hand, if needed.

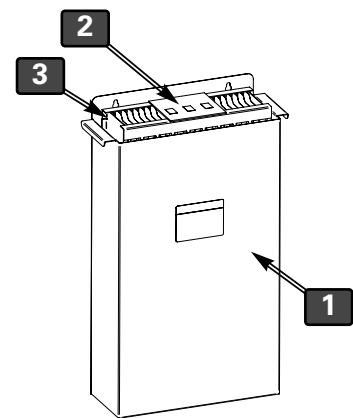

DO NOT WASH EAC CELL IN THE DISHWASHER!

NOTE: The degreasing solution can be used for approximately 30 days. It should then be discarded and refreshed

CAUTION

- Do not dry the EAC either by running the hood to air dry or by running the appliance to heat dry. This could potentially damage the EAC causing improper operation and voiding the warranty.

4-02.10. Charcoal Filter Removal

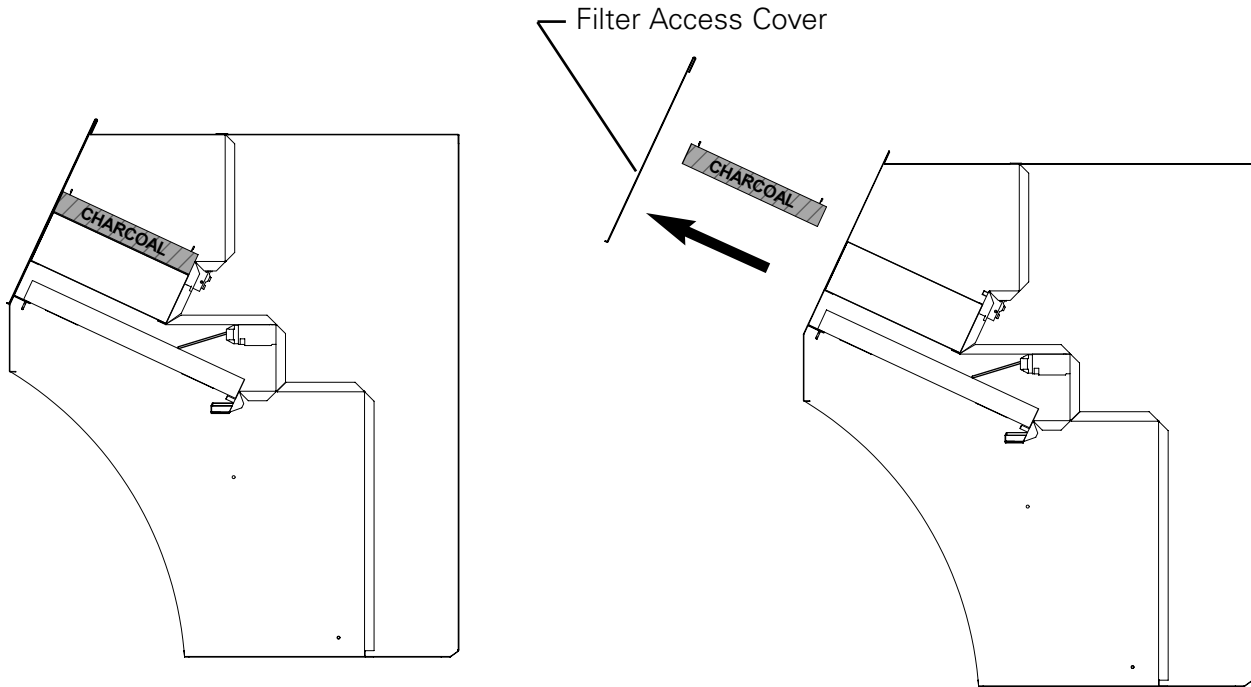

4-02.11. Charcoal Filter Installaton

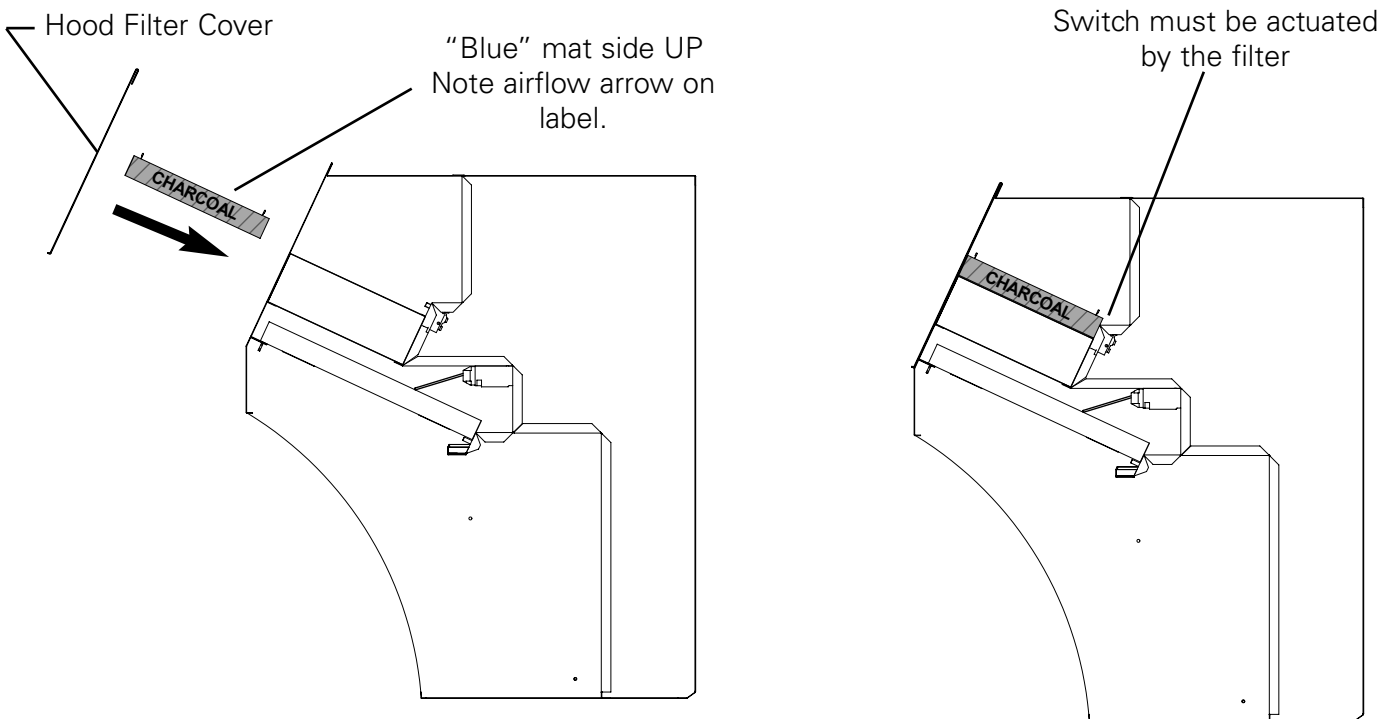

4-02.12. Charcoal Filter Missing

If the Charcoal Filter is missing or not properly installed, the Filter Missing Light **1** will illuminate and power to the under-hood appliance is disabled until the condition is corrected. See Section 4-02.11 Charcoal Filter Installation.

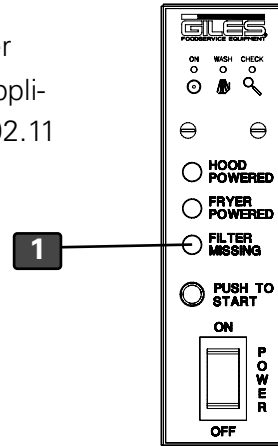

4-02.13. Charcoal Replacement Procedure

CAUTION

- **Never attempt to clean and reuse a Charcoal Filter. This filter is only to be replaced. The reuse of a Charcoal Filter can cause damage to the unit.**

Replace the Charcoal Filter every 30 days. Use Replacement Part #30248.

4-02.14. Ultraviolet Lamp Removal

1. Place hood power switch in the **OFF** position.
2. Remove Filter Access Cover
3. Disconnect UV Lamp wiring harness from power supply wiring harness .
4. Loosen and remove (2) thumb screws and remove Lamp Guard.
5. Remove Lamp from holding brackets.

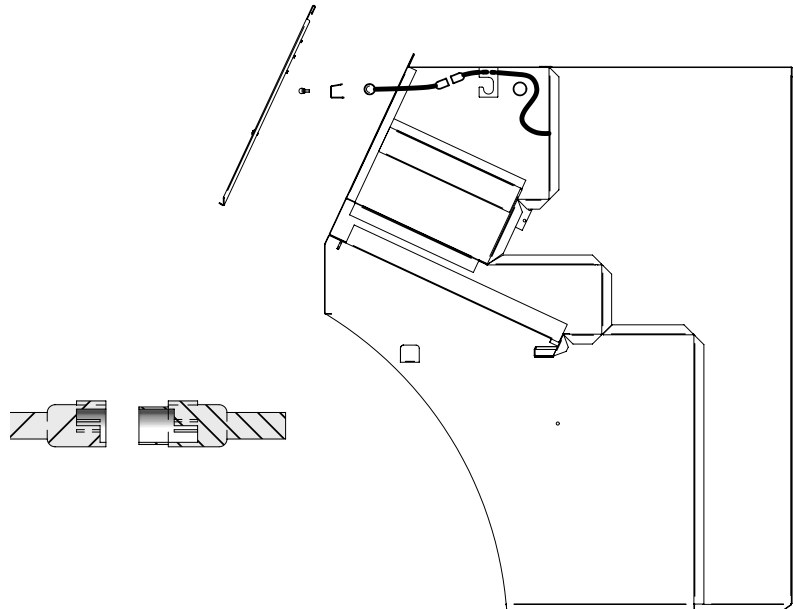

4-02.15. Ultraviolet Lamp Installation

1. Install new UV Lamp in holding brackets. **AVOID TOUCHING BULB PORTION OF LAMP WITH BARE HANDS.**
2. Install Lamp Guard and tighten thumb screws.
3. Connect UV Lamp wiring harness to power supply wiring harness.
4. Place hood power switch in the **ON** position.

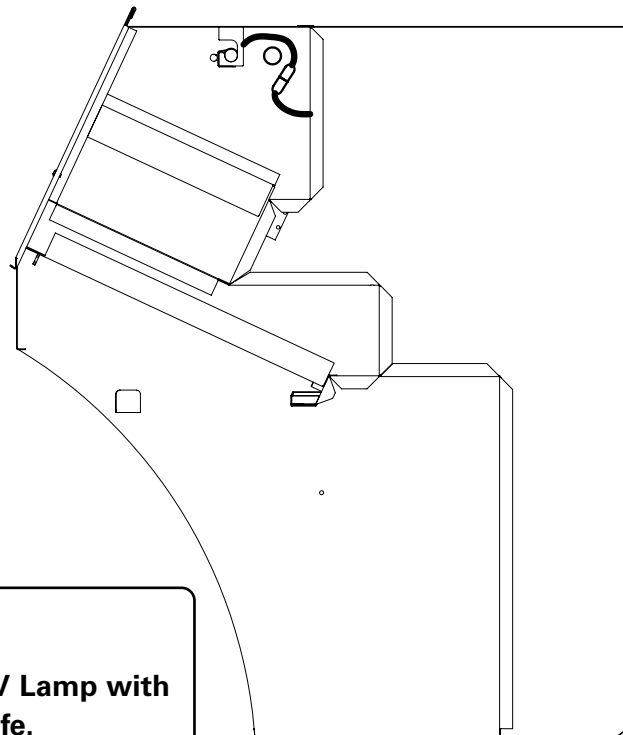

CAUTION

- **DO NOT touch or handle bulb portion of UV Lamp with bare hands. This will greatly reduce lamp life.**

4-02.16. Ultraviolet Lamp Cleaning

CAUTION

- **DO NOT touch or handle bulb portion of UV Lamp with bare hands. This will greatly reduce lamp life.**

Cleaning should be performed every 30 days

1. Place hood power switch in the **OFF** position.
2. Remove Filter Access Cover.
3. Loosen and remove (2) thumb screws and remove Lamp Guard.
4. Lightly spray a mild non-caustic biodegradable degreaser, such as **Simple Green**, onto the UV Lamp and allow to soak for a few seconds. Wipe off residue with a clean, dry, lint free cloth.
5. Re-install Lamp Guard.

4-03. Maintenance

This Section describes periodic maintenance for the Ventless Hood System. Performance of these procedures will help to maintain the unit's efficiency over time.

A **Maintenance and Service Log** is provided in this manual, see Section 4-03.06.

4-03.01. Monthly Interlock Check

The Giles Ventless Hood System incorporates an Interlock System to ensure the unit is operates in a safe and effective manner. Testing of the Interlock System should be conducted MONTHLY in the following manner. Use the form located in Section 4-06.06 Maintenance and Service Log, place a check in the box that corresponds to the test being performed. If a problem is found, call your service representative.

1. **Baffle Filter Check:** With the Power Switch in the **OFF** position remove the grease baffle. Place the Power Switch in the **ON** position. Check the under-hood appliance power, the appliance should not turn on. Turn the Power Switch to the **OFF** position and reinstall the grease baffle filter.
2. **EAC Filter Check:** With the Power Switch in the **OFF** position remove the EAC and replace Filter Access Cover. Place the Power Switch in the **ON** position, wait two minutes. Intermitten alarm tone should sound. Check the under-hood appliance power, the appliance should not turn on. Turn the Power Switch to the **OFF** position and reinstall the EAC.
3. **Charcoal Filter Check:** With the Power Switch in the **OFF** position remove the Charcoal Filter and replace Filter Access Cover. Place the Power Switch in the **ON** position. Check the under-hood appliance power, the appliance should not turn on. Return the Power Switch to the **OFF** position and reinstall the charcoal filter.
4. **Filter Clogged Check:** Place Hood power switch in the **ON** position. The blower will start and a continuous tone alarm should sound for 2 to 8 seconds until the blower reaches speed, then silence. Check appliance power during this time; there should be no power supplied to appliance until the alarm silences. If the alarm tone does not sound, fails to silence, and/or the appliance fails to come on or comes on before the alarm silences, contact service agent and have the Clogged Filter interlock checked. Return Hood power switch to the **OFF** position.

4-03.02. Semi-Annual Fire Suppression System Servicing

Service of the Fire Suppression System is to be conducted by qualified fire equipment personnel. As a minimum, field inspection of the Fire Suppression System is to be performed semi-annually by qualified fire equipment service personnel. Such maintenance shall consist of the following **(Consult the Giles Enterprises Design Installation, Recharge and Maintenance Manual for complete servicing guidelines)**.

Place fire extinguishing system locking bar on fire system when servicing hood.

1. Remove charging cartridge, inspect gasket for cuts and elasticity, coat gasket with extreme temperature grease and reinstall. See Section 2-06.01. Fusible Link and Gas Cartridge Locations
2. Remove tank, verify chemical is at proper level, clean and coat O-ring with extreme temperature grease and reinstall. See Section 2-06.02. Fire Extinguisher Nozzle and Tank Locations
3. Check all nozzles to insure they are free of cooking grease buildup.
4. Test the remote manual pull station for activation and wear.
5. Install test link and cut to simulate automatic actuation.
6. Clean and inspect fusible links. See Section 2-06.01. for Fusible Link and Gas Cartridge Locations
7. Inspect wire rope for wear at pulleys and detectors and replace if necessary.
8. Record maintenance date and maintain in a permanent file.

4-03.03. Annual Fire Suppression System Servicing

Same as Semi-Annual but all fusible links must be replaced with new fusible links. See Section 2-06.01. Fusible Link and Gas Cartridge Locations.

4-03.04. Annual UV System Servicing

CAUTION

• **DO NOT touch or handle bulb portion of UV Lamp with bare hands. This will greatly reduce the life of bulb.**

Replace Ultraviolet Lamp annually.

4-03.05. Twelve Year Suppression System Servicing

Same as Annual except for the following.

1. Replace R-102 fire suppression chemical.
2. Hydrostatically test the tank and cartridge.
3. Flow test the regulator.

4-03.06. Maintenance and Service Log

Check								Initial/Date	Check								Initial/Date			
✓	✓	✓	✓					ABC 1/2/03	1	2	3	4								
1	2	3	4						1	2	3	4								
1	2	3	4	5					1	2	3	4	5							
1	2	3	4						1	2	3	4								
1	2	3	4						1	2	3	4								
1	2	3	4	5	6*				1	2	3	4	5	6*						
1	2	3	4						1	2	3	4								
1	2	3	4						1	2	3	4								
1	2	3	4	5					1	2	3	4	5							
1	2	3	4						1	2	3	4								
1	2	3	4						1	2	3	4								
1	2	3	4	5	6*	7*	8		1	2	3	4	5	6*	7*	8				
1	2	3	4						1	2	3	4								
1	2	3	4						1	2	3	4								
1	2	3	4	5					1	2	3	4	5							
1	2	3	4						1	2	3	4								
1	2	3	4						1	2	3	4								
1	2	3	4	5	6*				1	2	3	4	5	6*						
1	2	3	4						1	2	3	4								
1	2	3	4						1	2	3	4								
1	2	3	4	5					1	2	3	4	5							
1	2	3	4						1	2	3	4								
1	2	3	4						1	2	3	4								
1	2	3	4	5	6*	7*	8		1	2	3	4	5	6*	7*	8				
1	2	3	4						1	2	3	4								
1	2	3	4	5					1	2	3	4	5							
1	2	3	4						1	2	3	4								
1	2	3	4						1	2	3	4								
1	2	3	4	5	6*				1	2	3	4	5	6*						
1	2	3	4						1	2	3	4								
1	2	3	4	5					1	2	3	4	5							
1	2	3	4	5					1	2	3	4								
1	2	3	4	5					1	2	3	4								
1	2	3	4	5	6*	7*	8		1	2	3	4	5	6*	7*	8				

- | | | | | | |
|---|---|---|--------------------|---|--|
| 1 | Baffle Filter Check | 2 | EAC Filter Check | 3 | Charcoal Filter Check |
| 4 | Filter Clogged | 5 | Quarterly Cleaning | 6 | Fire Suppression System |
| 7 | Fire Suppression System replace Fusible Links | | | 8 | Replace UV Lamp
<i>(UV Option Only)</i> |

* Inspection performed by a qualified fire equipment company.



Notes:

5. *General Hood Cleaning*

This section describes Hood cleaning.

CAUTION

- **DO NOT** steam clean.
- **DO NOT** use products containing chlorine.
- **DO NOT** use abrasive products, steel wool or scouring pads.

Before performing any cleaning activities, disconnect Hood and Appliance power at the main breaker.

5-01. Weekly Cleaning

Exterior: Use a good quality stainless steel cleaner to clean all external stainless steel surfaces.

Skirt Section: Use a mild, non-caustic degreaser to clean the inside surfaces of the hood's skirt section directly above the appliance.

Weekly cleaning should also include filters and UV lamp as previously described. See Section 4.02.01 Hood Filter Table.

5-02. Quarterly Hood Cleaning

Disconnect power to the unit. Remove the Filter Access Cover and all Filters from the hood. Using a soft cloth, sponge or towel and a mild, non-caustic, bio-degradable degreaser, clean the entire Hood Plenum area and Filter Channels. Inspect blower and if there is evidence of grease build-up, thoroughly clean the fan blades.



Notes:

6. Troubleshooting

This section describes troubleshooting procedures for the FSH-2, FSH-2A-99. Refer to the wiring diagram provided with the unit as needed for more detailed analysis.

DANGER

- Electrical troubleshooting procedures should be performed **ONLY** by qualified service personnel. Death or serious injury will result from contact with energized electrical components.
- Failure to comply with these **DANGER** notices will result in death or serious injury, equipment or property damage, and void the warranty.

6-01. Troubleshooting Procedures

Problem	Probable Cause	Repair Procedure
Hood will not turn on	a. (ILS only) "Push to Start" button not held for 5 seconds	a. Hold down "Push to Start" button until unit remains running
	b. Power switch bad	b. Replace power switch.
	c. Improper supply voltage	c. Connect to proper voltage source.
	d. Hood cover not closed	d. Close hood cover.
	e. Not connected to power source	e. Connect to proper power source.
	f. Circuit breaker tripped	f. Reset Circuit breaker.
Filter Missing Light on	a. Baffle filter is not installed	a. Install Baffle filter.
	b. Charcoal filter is not installed	b. Install charcoal filter.
	c. One or both improperly installed.	c. Properly install filters
Check or Wash Light on	a. EAC shorted	a. Replace or repair EAC.
	b. EAC dirty	b. Clean EAC.
	c. High voltage power supply faulty.	c. Replace high voltage power supply
	d. High voltage wires shorted.	d. Correct shorted condition.
	e. Bad contact plate	e. Replace contact plate.

6-01. Troubleshooting Procedures (Cont'd.)

Problem	Probable Cause	Repair Procedure
Fryer will not turn on and ... • Hood Power Light is ON • Filter Missing Light is ON	a. Baffle Filter missing	a. Install Baffle Filter
	b. Baffle Filter not installed properly	b. Reinstall Baffle Filter
	c. Charcoal Filter missing	c. Install Charcoal Filter
Fryer will not turn on and ... • Hood Power Light is ON • Continuous tone alarm sounding • Fryer Powered light is OFF	a. Charcoal Filter clogged	a. Replace Charcoal Filter
	b. Baffle Filter clogged	b. Clean Baffle Filter
	c. Vacuum switch out of adjustment	c. Adjust Vacuum switch only.
	d. Kinked vacuum line	d. Remove vacuum line kinks
	e. Fan running slow	e. Check voltage
Fryer will not turn on and ... • Hood Power Light is ON • Pulsating tone alarm sounding • Fryer Powered Light is OFF	a. EAC shorted	a. Repair EAC
	b. EAC dirty	b. Clean EAC
	c. EAC power supply faulty	c. Replace EAC power supply
	d. EAC wires shorted	d. Check voltage
	e. Bad contact plate	e. Replace contact plate
	f. EAC module faulty	f. Replace EAC module
	g. Too many EAC ionizer wires broken or missing	g. Replace ionizer wires
UV Lamp not illuminated	a. Bad Connection	a. Reconnect
	b. Lamp blown	b. Replace Lamp
	c. Filters not installed correctly	c. Install filters
	d. Access Pannel not installed	d. Install Access Panel
	e. Bad Ballast	e. Replace Ballast

7. Parts List

This section lists various parts that are available for replacement on the FSH2, FSH-2A-99.

7-01. Parts Ordering and Service Information

If you require assistance or need repairs, please contact a Giles Manufacturer's Representative to assist with locating an authorized service provider in your area. For further assistance, please contact the Giles Enterprises, Inc. factory at the following phone numbers:

IN THE UNITED STATES, CANADA or MEXICO

Call **800.554.4537** during normal business hours, 8:00 AM to 5:00 PM Central Time; other than normal business hours, call **800.554.4537** and follow recorded prompts to reach after-hours support.

IN ALL OTHER COUNTRIES

Call **334.272.1457** during normal business hours, 8:00 AM to 5:00 PM Central Time; other than normal business hours, call **334.272.1457** and follow the recorded prompts.

INTERNET

Please visit our website at: www.gfse.com or e-mail services@gfse.com.

The goal of the Giles team is to provide you with the highest quality service and assistance possible. To help us accomplish this please have the following information readily available when calling, along with the nature of the problem you are encountering. This information is recorded on a Serial Plate or Label attached to the unit.

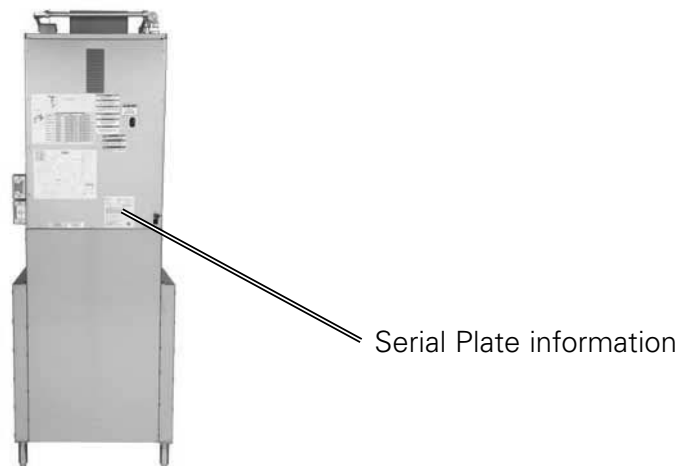

The area below may be helpful in recording information for use as a quick reference.

Model: _____

Serial Number: _____

Phase: _____

Voltage: _____

7-02. Ventless Hood - Front

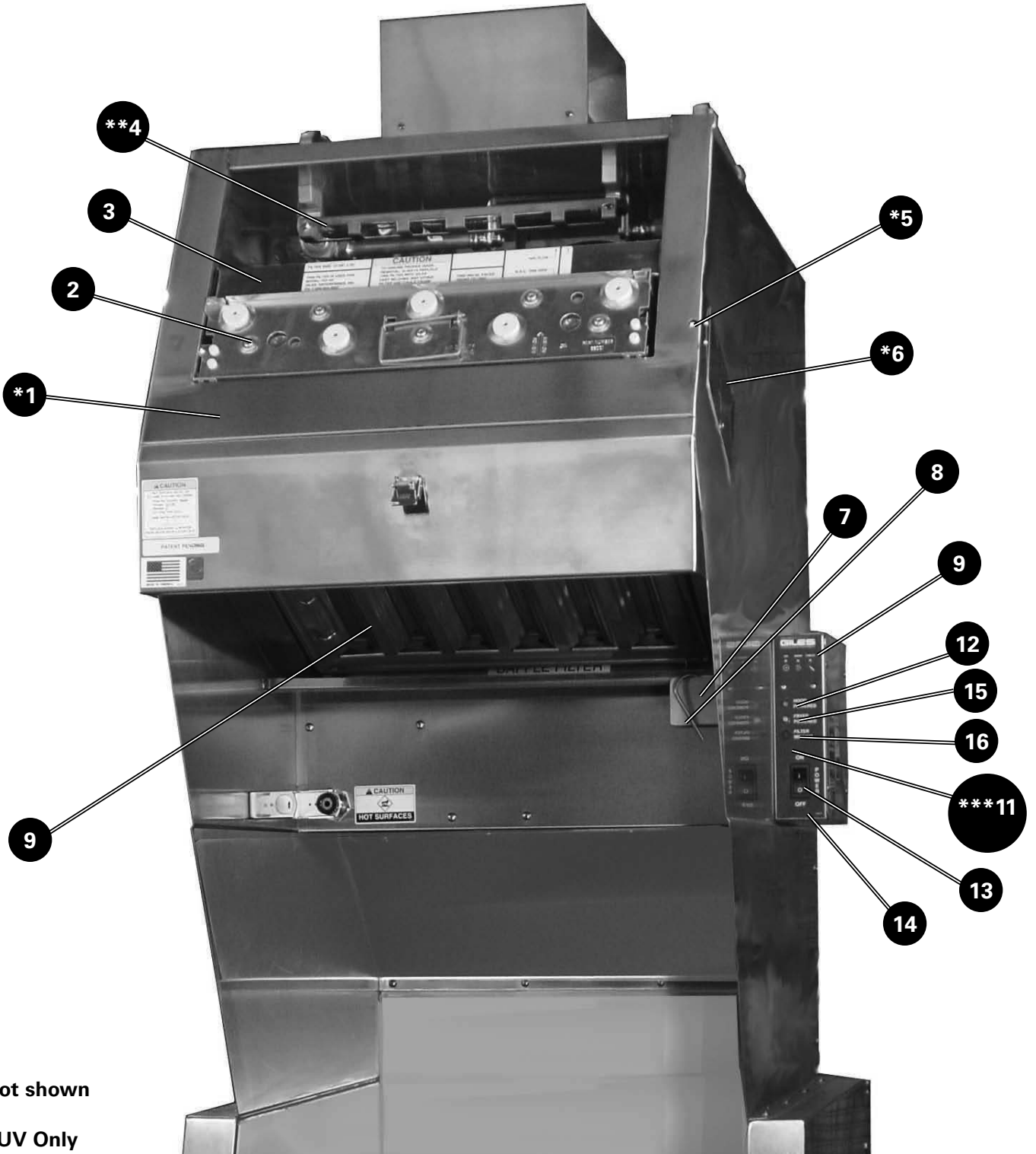

* Not shown

** UV Only

*** Not shown & ILS only

7-02. Parts List for Front Ventless Hood -Front

Item No.	Part No.	Qty.	Description
*1	90261	1	FILTER ACCESS PANEL, WELD ASSY
**1	90262	1	FILTER ACCESS PANEL, ASSY, FSH-2-UV
2	20520	1	FILTER, EAC, 20 IN
3	30248	1	FILTER, CHARCOAL, ASSY, 20 X 12.375 X 2
**4	90226	1	LAMP, ASSY, 16-IN, UV, REPLACEMENT ONLY
*5	23200	1	SWITCH, SNAP ACTION, ROLLER TYP
6	21125	1	BOARD, CONTACT, EAC, VH UNITS
7	30206	1	DRIP CUP, WELD ASSY
8	34750	1	PIN, DRIP CUP SAFETY
9	42300	1	FILTER, BAFFLE, 20X20, S/S, LARGE VH
10	24209	1	L.E.D. CLUSTER, AIR FILTER, EAC
***11	23173	1	SWITCH, MOMENTARY
12	22277	1	INDICATOR LIGHT, GREEN
13	21190	1	SWITCH, ROCKER, ON-OFF, 250V, 20A, DPST
14	64460	1	LABEL, CONTROL PANEL, FSH-2
15	38213	1	INDICATOR LIGHT, ORANGE
16	38214	1	INDICATOR LIGHT, RED

* Not shown

** UV Only

*** Not shown & ILS only

7-03. Ventless Hood - Rear

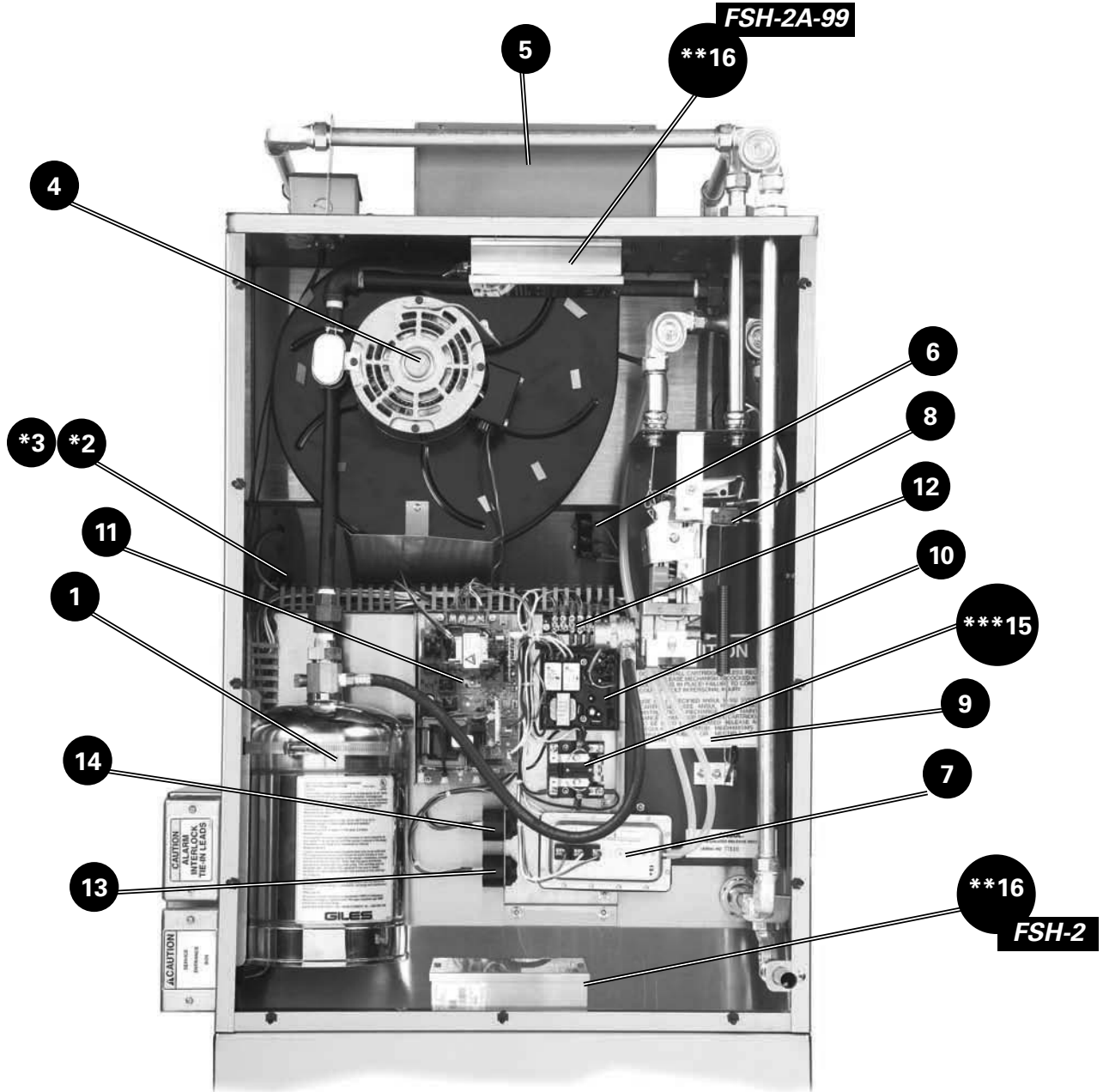

* Not shown

** UV Only

*** ILS Only (FSH-2A-99)

7-03. Parts List for Ventless Hood -Rear

Item No.	Part No.	Qty.	Description
1	39272	1	TANK, 1.5 GAL. & LABEL ASSY.
*2	23778	1	SWITCH, SIDE ROTARY, 240V, 30A, W/O ARM
*3	23779	1	ROD, ADJUSTMENT
4	33589	1	BLOWER, ASSY, VH-FRYERS
5	46125	1	DAMPER, FIRE, 10 X 10, 285 DEG LINK
6	24237	1	SWITCH, PLUNGER, 250V, 15A
7	23001	1	SWITCH, VACUUM, HOSE BARB
8	20002	1	SWITCH, ANSUL, SHUTDOWN/ALARM, 15A, 120V
9	40132	1	BRACKET & RELEASE, ANSUL
10	23776	1	MODULE, AIR FILTER, ALARM AND SHUTDOWN
11	24208	1	POWER SUPPLY, W/DRIVER BRD, 208-240V,EAC
12	23751	1	TERMINAL BLOCK, MA106
13	23782	1	SONALERT, 250V, CONTINUOUS BEEP
14	22950	1	SONALERT, 250V, INTERMITTENT
***15	21174	1	RELAY, 30A, 240V, 2PL
**16	20373	1	UV-LAMP, ASSY (BALLAST & LAMP)

* Not shown

** UV Only

*** ILS Only (FSH-2A-99)

Model: FSH-2, FSH-2A-99

Parts List



Notes:





Giles Enterprises, Inc.

P.O. Box 210247 • 2750 Gunter Park Drive West • Montgomery, Al 36121-0247 USA
Phone: 334.272.1457 • Service Hotline: 800.554.4537 (USA & Canada Only) • FAX: 334.239.4117 • www.gfse.com

Form No. 60200 (Release date: 07/98)(Revision date: 09/30/12; Rev. G)