

Operations & Service Manual

FSH-3.5 & FSH-4



Model: FSH-3.5 & FSH-4



Giles Enterprises, Inc.

ISO 9001 Registered Company • Committed to Quality
2750 Gunter Park Drive West • Montgomery, AL 36109 USA
Phone: 334.272.1457 • Fax: 334.239.4117 • Website: www.gfsequipment.com
Service Hotline (Toll Free): 800.554.4537 (USA & Canada Only)
Form No. 65497 (Release date: 04/09) (Revision Date: 08/10, Rev. B)



LIMITED WARRANTY

- Subject to the terms and conditions of this Limited Warranty as herein stated, all Giles Enterprises, Inc., Foodservice Equipment and parts purchased new from an authorized Giles Enterprises, Inc., representative are warranted as to defects in material or workmanship for a period of 12 months from the date of installation, provided, however, that with regard to labor costs in connection with this warranty, see below. All installations must be made by a qualified installing agency in accordance with all applicable codes and/or regulations in the jurisdiction in which installed. Limited warranty coverage is extended to the original owner only and is void if the unit is resold.
- During the Limited Warranty period, Giles Enterprises, Inc. will replace or recondition, at its factory, any part or parts of this unit which Giles Enterprises, Inc. inspectors judge defective, provided the unit has been subjected to normal usage, properly installed, operated and serviced. This Limited Warranty does not cover cosmetic damage, and damage due to acts of God, accident, misuse, alteration, negligence, abuse of the Giles Foodservice Equipment or the use of unorthodox repair methods. All parts replaced under this Limited Warranty carry only the unexpired term of this Limited Warranty. Limited Warranty service may be furnished only by an authorized Giles Enterprises, Inc., representative.
- If Limited Warranty service is requested, Giles Enterprises, Inc., will send factory-authorized service representatives to repair, recondition, replace or inspect units of its manufacture with such labor being rendered without cost to owner for ninety (90) days from the date of installation. Otherwise, service, including labor and transportation charges or other expenses, in connection with the removal or installation of any part or parts supplied under this Limited Warranty, are specified on the original sales contract between the purchaser and the authorized Giles Enterprises, Inc., representative.
- Giles Enterprises, Inc. reserves the right to change or improve its equipment and parts in any way without obligation to alter such equipment or parts previously manufactured.
- Giles Enterprises, Inc. makes no further warranties, express or implied including implied warranties of merchantability or fitness for a particular purpose, and has no other obligation or liability not specifically stated herein.
- Repair or replacement as provided under this limited warranty is the exclusive remedy. Giles Enterprises, Inc., shall not be liable for any incidental or consequential damages for breach of any express or implied warranty on this product, except to the extent prohibited by applicable law. Any implied warranty of merchantability or fitness for a particular purpose on this product is limited in duration to the duration of this limited warranty.
- Used Giles Enterprises, Inc., Foodservice Equipment or parts or Giles Enterprises, Inc., Foodservice Equipment or parts not purchased from an authorized Giles Enterprises, Inc., representative, carry no warranties, express or implied.

Safety	v
Safety Overview	v
Specific Safety Precautions	vi
1. Introduction	1
1-1. Construction	1
1-2. Standard Features	1
1-3. Optional Features	1
1-4. Specifications	2
1-4.1. Overall Dimensions	2
1-4.3. Regulatory Listings	4
1-4.4. Hood Weights	4
2. Installation	5
2-01. Unpacking	5
2-02. Location	6
2-03.1. Ceiling Mount Hood Mounting Detail	6
2-03.2. Hood Skirt Installation	7
2-03.3. Free Standing Mounting Detail	8
2-04. Cooking Appliance limitations and clearances	9
2-04.1. Fryer limitations	9
2-04.2. Fryer clearances	9
2-04.3. Oven limitations	10
2-04.4. Oven clearances	10
2-04.5. Griddle limitations	11
2-04.6. Griddle clearances	11
2-04.7. Range limitations	12
2-04.8. Range clearances	12
2-05. Hood Electrical Requirements	13
2-05.1. Electrical Connections	13
2-05.2. Routing Power Wires	14
2-05.3. Hood and Appliance Interlock Diagram	15
2-06. Fire Suppression System Installation	15
2-06.1. Fire Suppression System Routing	15
2-06.2. Fire Suppression Fusible Links	16
2-06.3. Appliance Nozzles	16
2-06.4. Fire Extinguisher Nozzle Locations	17
2-06.5. General Maintenance	17
3. Overview	19
3-01. Control Panel	20
3-02. Filter Chamber and Exhaust	22
3-03. Accessories (Included)	24

4. Operation & Filter Maintenance 27

4-01. Hood Operation 27

4-02. Filters and Filter Maintenance 27

4-02.01. Ventless Hood Filter Table 27

4-02.02. Baffle Filter Removal. 28

4-02.03. Baffle Filter Installation 29

4-02.04. Baffle Filter Missing 29

4-02.05. Baffle Filter Cleaning. 30

4-02.06. Pre-Filter Removal. 30

4-02.07. Pre-Filter Installation. 31

4-02.08. Pre-Filter Filter Missing. 31

4-02.09. Pre-Filter Replacement. 32

4-02.10. EAC Filter Removal. 32

4-02.11. EAC Filter Installation 33

4-02.12. EAC Filter Status. 34

4-02.13. EAC Filter Cleaning. 34

4-02.14. Charcoal Filter Removal 35

4-02.15. Charcoal Filter Installation 36

4-02.16. Charcoal Filter Missing. 36

4-02.17. Charcoal Filter Replacement. 37

4-03. Filter Alarm Chart 37

5. Hood Cleaning and Maintenance 39

5-1. Monthly Interlock Check. 39

5-2. Quarterly Hood Cleaning 39

5-3. Semi-Annual Fire Suppression System 40

5-4. Annual Fire Suppression System 40

5-5. 12 Year Fire Suppression System 40

5-6. Maintenance and Service Log 41

6. Troubleshooting 43

6-1. Troubleshooting Procedures 43

Parts List 45

7-1. Parts Ordering and Service Information 45

7-2. Component Drawer 47

7-3. Front View -Doors and Panel removed 49

7-4. Baffle Filters and Switches 51

7-5. Doors and Front Panel (Ceiling Mounted). 53

7-6. Doors and Front Panel (Free-Standing). 55

Safety

Safety Overview

The instructions contained in this manual have been prepared to aid you in learning the proper procedures for installing and servicing your unit.

Throughout this manual, safety precautions are identified through the use of the safety alert symbol and three signal words: **DANGER, WARNING**, and **CAUTION**. All safety alert information precedes the step(s) to which they apply. Suggested, recommended, or other noteworthy information is identified through the use of **NOTES**. Additionally, certain words are used to indicate a specific meaning or to add emphasis.

The following words are used as indicated throughout the manual:

Shall: understood to be mandatory.

Should: understood to be advisory.

May: understood to be permissive.

Will: indicates a future event/condition to occur.

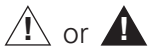

(Safety Alert Symbol)

Used in conjunction with signal words (**DANGER, WARNING**, or **CAUTION**) to alert you of potential personal injury hazards, immediately preceding precautionary measures that pertain to subsequent step(s). Obey all safety messages that follow this symbol to avoid possible injury or death. Failure to adhere to safety precautions identified by the safety alert symbol may also void the warranty.

DANGER

- Indicates an imminently hazardous situation which, if not avoided, will result in death or serious injury. Use of this is limited to the most extreme situations.

WARNING

- Indicates a potentially hazardous situation which, if not avoided, could result in death or serious injury.

CAUTION

- Indicates a potentially hazardous situation which, if not avoided, may result in minor or moderate injury. Also used to alert against unsafe practices.

CAUTION

- When used without the safety alert symbol, **CAUTION** indicates a potentially hazardous situation which, if not avoided, may result in equipment/property damage, and void the warranty.

NOTE:

- Identifies suggested, recommended, or other noteworthy information.

Specific Safety Precautions

For your safety, please observe the following precautions when operating or servicing your Ventless Hood equipment. Read the following important safety information to avoid personal injury and/or damage to the equipment or property.

DANGER

- Always disconnect the source of the main power before removing the service entrance box cover.
- Failure to ensure the Power switch is in the “OFF” position during servicing and when replacing filters could result in equipment damage, electrical shock and/or personal injury.
- Failure to comply with these **DANGER** notices will result in death or serious injury, equipment/property damage, and void the warranty.

WARNING

- **DO NOT** use or store flammable liquids or materials that produce flammable vapors in the vicinity of this or any other appliance!
- Consult a qualified electrician to ensure all electrical specifications have been met and the unit is properly grounded.
- Before installing or servicing this equipment, read the contents of this manual thoroughly.
- Improper installation, adjustment, alteration, service or maintenance could result in death or serious injury, equipment/property damage, and void the warranty.
- Failure to comply with these **WARNING** notices could result in death or serious injury and equipment/property damage.

CAUTION

- Maintain a minimum clearance of 14" (355.6mm) between the hood outlet and the ceiling or any obstruction above the hood. **18" (457.2mm) is recommended for best performance.**
- Exercise care when lifting or moving the unit. See Section 1-4.4 for Hood weights.
- Exercise care when removing the wooden crate from around the unit.

CAUTION

- **DO NOT** operate the unit unless you fully understand the components and their intended function.
- Be careful not to bend the fins or break the ionizer wires on the Electrostatic Air Cleaner (EAC). Doing so will prevent the EAC from working properly and cause a shutdown of power to the appliance being used with the hood.
- Failure to comply with these **CAUTION** notices may result in minor or moderate injury, equipment/property damage, and void the warranty.

CAUTION

- The electronic components of the Control Panel are impact-sensitive. Exercise care around the Control Panel to maintain proper operation.
- Do not attempt to dry the EAC after cleaning by installing it and running the hood to force air dry or by running an appliance below to heat dry. This could potentially damage the EAC system leading to failure and voiding the warranty. The filter must air dry at ambient room temperature, preferably overnight.
- During cleaning of Hood.
 - **DO NOT** steam clean.
 - **DO NOT** use products containing chlorine.
 - **DO NOT** use abrasive products, steel wool or scouring pads.
- Failure to comply with these **CAUTION** notices may result in equipment/property damage and void the warranty.

NOTE:

- If upon receipt, the palletized unit shows any signs of damaged, immediately inspect the entire Ventless Hood and the included accessories, and promptly notify the freight company of any damages.
- To aid the electrician, an electrical wiring diagram is attached inside the back cover of this manual. Refer to the wiring diagram during installation or servicing. A wiring diagram is also attached to the inside of the filter access door.
- Comply with all appropriate state and/or local health regulations regarding the cleaning and sanitation of equipment.
- For cleaning areas with excessive particulate build up, a mild bio-degradable non-toxic degreaser (such as Clear Magic or Simple Green) may be used.
- Always ensure the unit is electrically grounded and installed in accordance with local codes, or in the absence of local codes, in accordance with the National Electrical Code ANSI/NFPA No. 70-1984.

NOTE:

- The decibel level of the hood when operating is approximately 73 dB.

NOTE:

- **A HVAC specialist may be required for installations to confirm proper air exchange and the heat load capabilities of the on-site AC system.**
- Exhaust ventilation is recommended for areas in which recirculating hoods are used. We recommend 50 CFM per lineal ft. of hood.
- This amount could vary based on local codes and the site specific installation requirements.

1. Introduction

Congratulations on the purchase of a new FSH-3.5 or FSH-4 Giles Ventless Hood System manufactured by Giles Enterprises, Inc., Montgomery, Alabama (USA), hereafter referred to as "Giles". These two models are available in either ceiling mounted or free-stand mounted versions. The stand mounted version is available in a 72" or 78" height (measured from the floor to the bottom edge on the hood skirt).

Proper care and maintenance of this unit will ensure years of trouble-free service and to help protect your investment in this equipment, we recommend taking a few moments to familiarize yourself with the installation, cleaning, and maintenance procedures described in this manual. We urge you to read these instructions before installing or using this hood. Adherence to these recommended procedures will minimize potential for costly downtime and equipment repairs. Please retain this manual for future reference.

1-1. Construction

The Ventless Hood System exterior is constructed of stainless steel.

1-2. Standard Features

Control Panel

- Two LED light clusters indicate the status of the left and right EAC filters.
- "Appliance Powered" light indicates that power is being supplied to the interlocked appliance(s) under the hood.
- "Filter Missing" light indicates that one (or more) Baffle filter, Pre-filter, and/or Charcoal filter is missing or installed improperly.
- "Filter Clogged" light indicates that the Baffle filters, Pre-filters, and/or Charcoal filters are possibly clogged and require attention to ensure proper hood performance.

Filters

- Baffle Filters - capture large grease particles in the air stream.
- Pre-Filters - capture the smaller grease particles.
- Electronic Air Cleaners (EAC) - capture smoke & fine particle air contaminants.
- Charcoal Filters - help eliminate cooking odors.

1-3. Optional Features

Inter-Locking Start System (ILS)

- Inter-Locking Start System (ILS) - Should there be a power interruption to the the hood, this system will not allow the Hood and the Appliance(s) below it to restart without the attendance of an operator. This system is required by code in some cities and/or states. Please consult with your local code officials to see if this option is required.

Floor Stand Mount

- 72" or 78" high stand mounts are available instead of the standard ceiling hung mount (*height measured from floor to bottom edge of skirt).

1-4. Specifications

1-4.1. Overall Dimensions for FSH-3.5 / 4 (Ceiling Mount Option)

DIM	FSH-3.5	FSH-4
(A)	42-11/16 [1084.4]	48-11/16 [1236.7]
(B)	37-11/16 [958.0] C to C	43-11/16 [1109.7] C to C
(C)	42-5/8 [1081.9]	48-5/8 [1235.1]

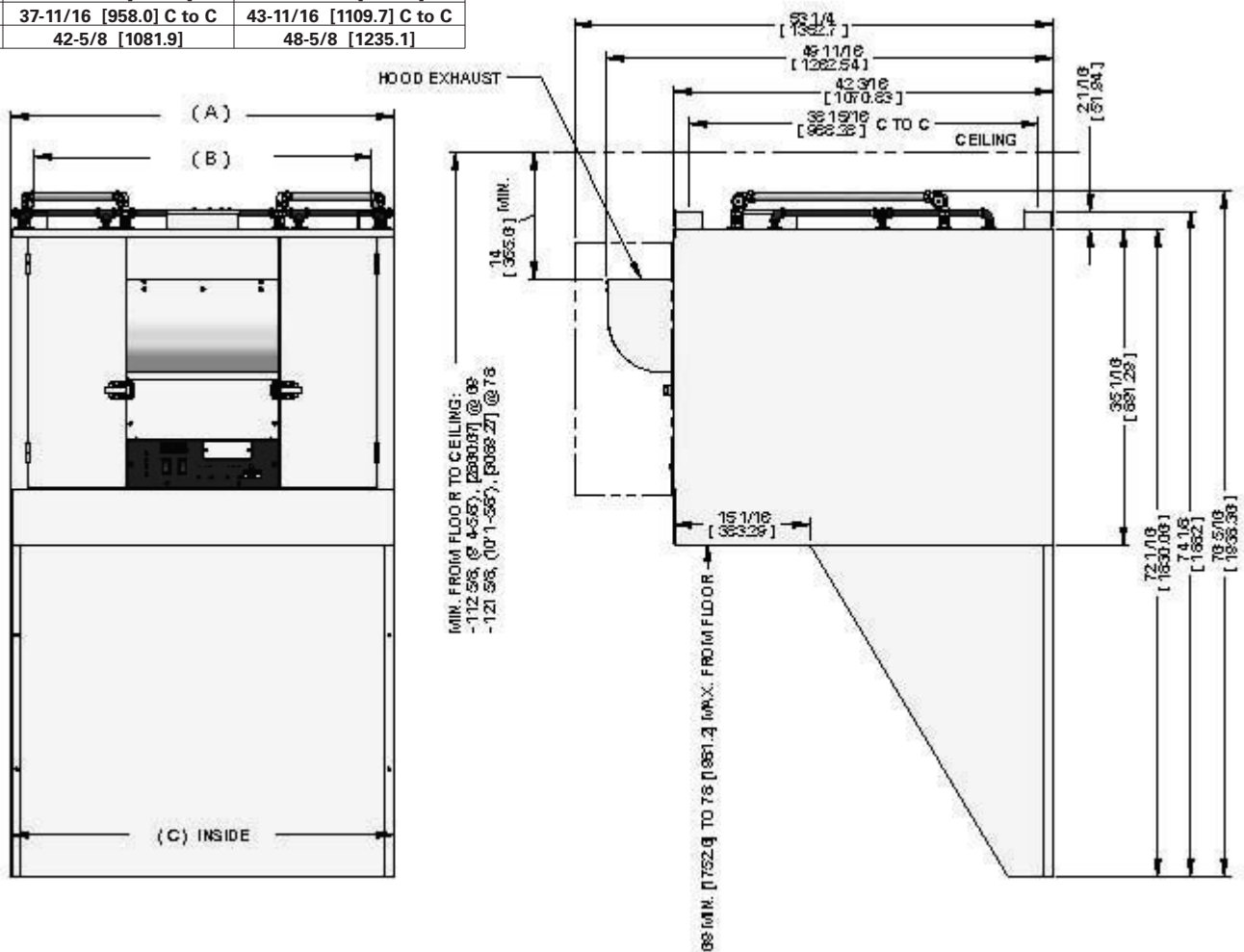

1-4.2. Overall Dimensions for FSH-3.5 / 4 (Free Standing Option)

DIM	FSH-3.5	FSH-4
(A)	42-11/16 [1084.4]	48-11/16 [1236.7]
(B)	39-1/16 [991.7]	45-1/16 [1144.6]
(C)	44-3/8 [1126.6]	50-3/8 [1279.5]
	(with 72" Stand Mt)	(with 78" Stand Mt)
(D)	72 [1828.8]	78 [1981.2]
(E)	115-5/8 [2936.9]	121-5/8 [3089.3]

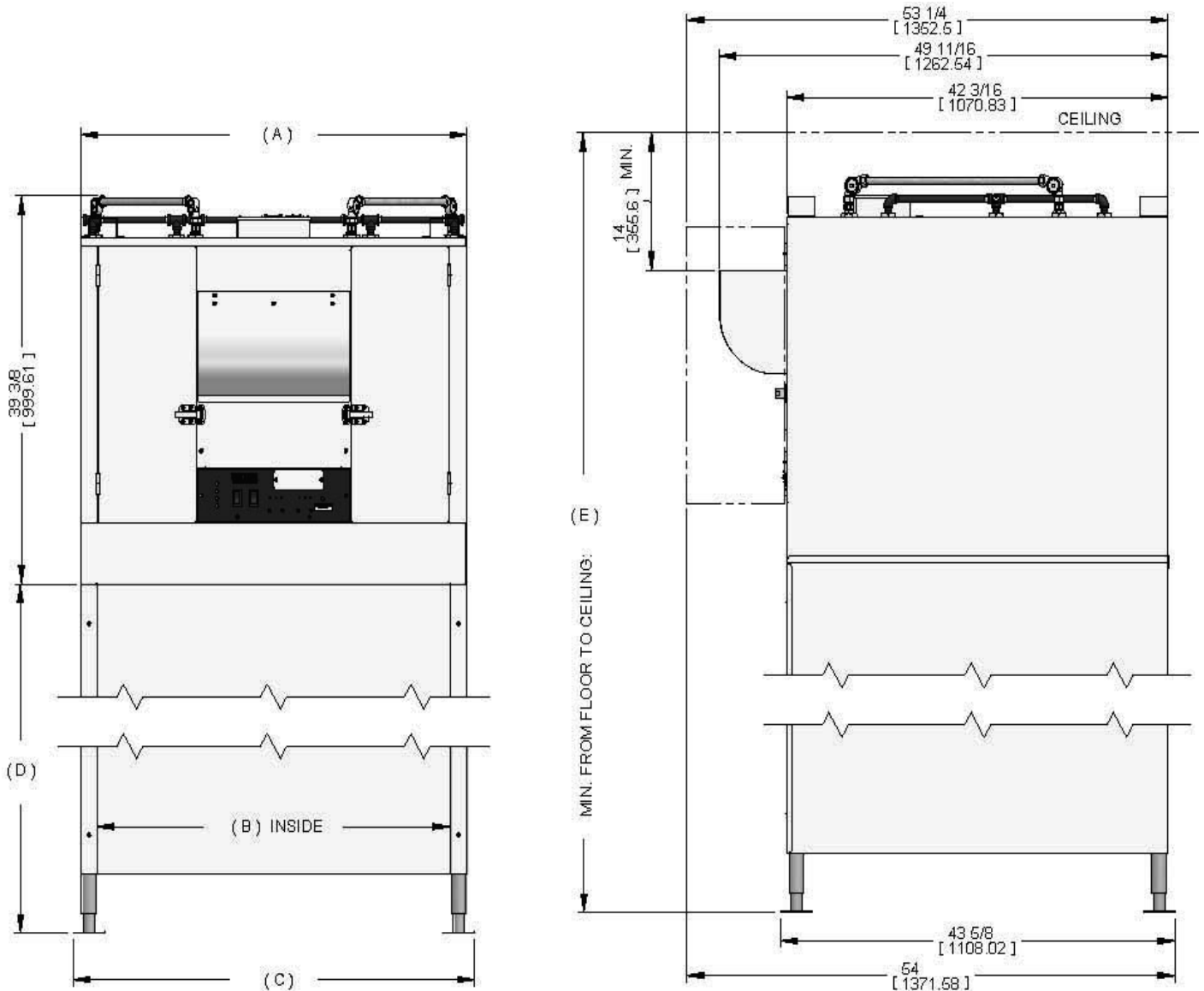

INCHES (MILLIMETERS)

1-4.3. Regulatory Listings



1-4.4. Hood Weights

Hood	Crated Weight	Uncrated Weight
FSH-3.5 (Ceiling Mt.)	664 lbs [302 kg]	464 lbs [211 kg]
FSH-3.5 (Stand Mt.)	733 lbs [333 kg]	553 lbs [251 kg]
FSH-4 (Ceiling Mt.)	724 lbs [328 kg]	524 lbs [243 kg]
FSH-4 (Stand Mt.)	793 lbs [368 kg]	613 lbs [284 kg]

2. Installation

This section summarizes the procedures necessary to install your new FSH-3.5 or FSH-4 Hood. Before installing or servicing this equipment, please read the contents of this manual thoroughly. Following these procedures will help ensure a safe and proper installation.

NOTE:

- **A HVAC specialist may be required for some installations to confirm proper air exchange and the heat load capabilities of the on-site AC system.**
- Exhaust ventilation is recommended for areas in which recirculating hoods are used. We recommend 50 CFM per lineal ft. of hood.
- This amount could vary based on local codes and the site specific installation requirements.

2-01. Unpacking

Your Ventless Hood should arrive palletized with a wooden protective frame, wrapped in machine applied stretch-wrap, and secured to by means of high-tensile plastic strapping. Perform the following steps to unpack the unit:

1. Position the palletized unit in an area that has sufficient space for unpacking.

!! IMPORTANT NOTE:

- If the palletized unit shows any signs of damage, immediately inspect the equipment and other packed components, and notify the freight company of any and all damages.

2. Cut and remove stretch-wrap and all strapping.
3. Use a hammer and pry-bar to remove the wooden crate from around the unit

⚠ CAUTION

- Use suitable equipment to lift the hood and carefully move it away from the pallet ... see Section 1-4.4 for hood weights. Take precautions not to damage to the hood's bottom skirting. If possible, it is advisable to rig and lift the hood from the topside, utilizing the hood's hanging brackets.
- Exercise care when removing the wooden framing from around the unit.
- Failure to comply with these **CAUTION** notices may result in minor or moderate injury, equipment or property damage, and void the warranty.

2-02. Location

NOTE:

- The decibel level of the hood when operating is approximately 73 db.

CAUTION

- **DO NOT MODIFY, ALTER OR ADD ATTACHMENTS TO THIS EQUIPMENT**

NOTE:

- **A HVAC specialist may be required for some installations to confirm proper air exchange and the heat load capabilities of the on-site AC system.**
- Exhaust ventilation is recommended for areas in which recirculating hoods are used. We recommend 50 CFM per lineal ft. of hood.
- This amount could vary based on local codes and the site specific installation requirements.

1. Do not obstruct the exhaust air outlet. Maintain a minimum clearance of **14 inches (355.6mm)** between the air outlet and ceiling, or any obstruction.
2. Ensure intended mounting site is structurally sound and capable of supporting the hood's weight. See Section 1-4.4 for hood weights

2-03.1 Hood Mounting Detail (Ceiling Mount)

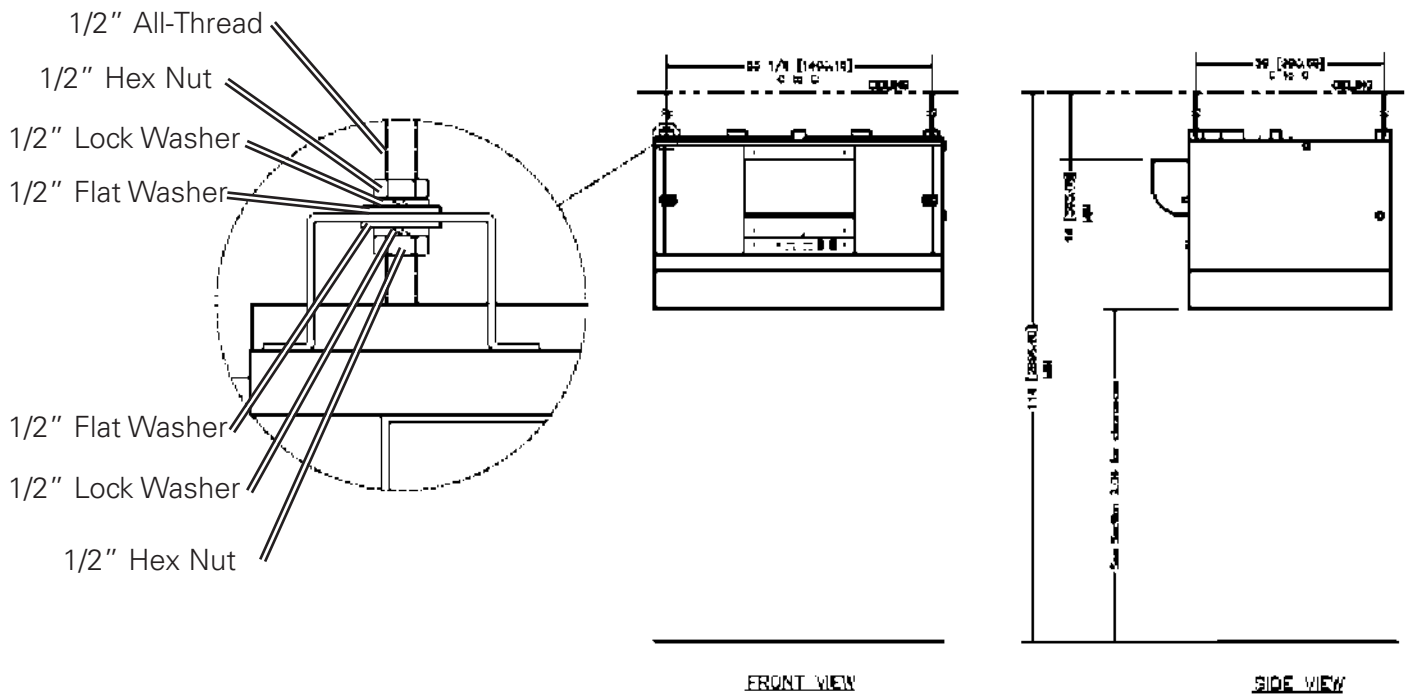

1. Ensure the hood is level, left to right and front to back.
2. Ensure all mounting fasteners are tight and secure.

2-03.2 Hood Skirt Installation (Ceiling Mount)

NOTE:

- Hood Skirts MUST be installed for proper air capture.

1. Apply a bead of Hi-Temp Silicone (included) to the top flanges of both Side Skirts.
2. Attach Left and Right Side Skirts to hood with enclosed fasteners (do not tighten completely).
3. Apply a bead of the Hi-Temp Silicone to the top flange of the Rear Skirt.
4. Attach Rear Skirt to hood with enclosed fasteners (do not tighten completely) .
5. Fasten Left and Right Skirts to Rear Skirt.
6. Completely tighten all fasteners and wipe any excess silicone from the assembled Skirt.

NOTE: Peel all protective film from parts before assembling.

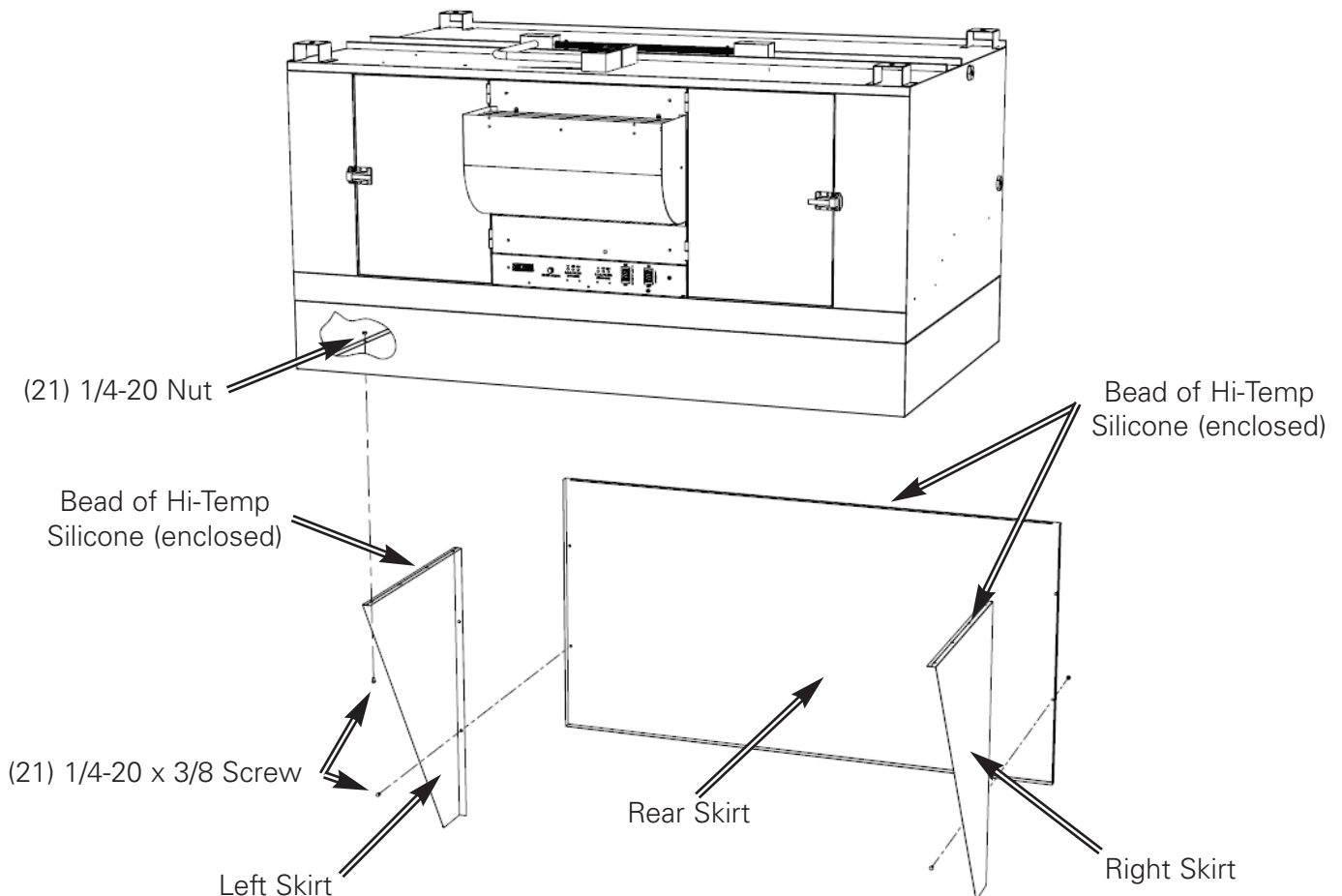

2-03.3 Hood Mounting Detail (Free-Standing)

STEP 1

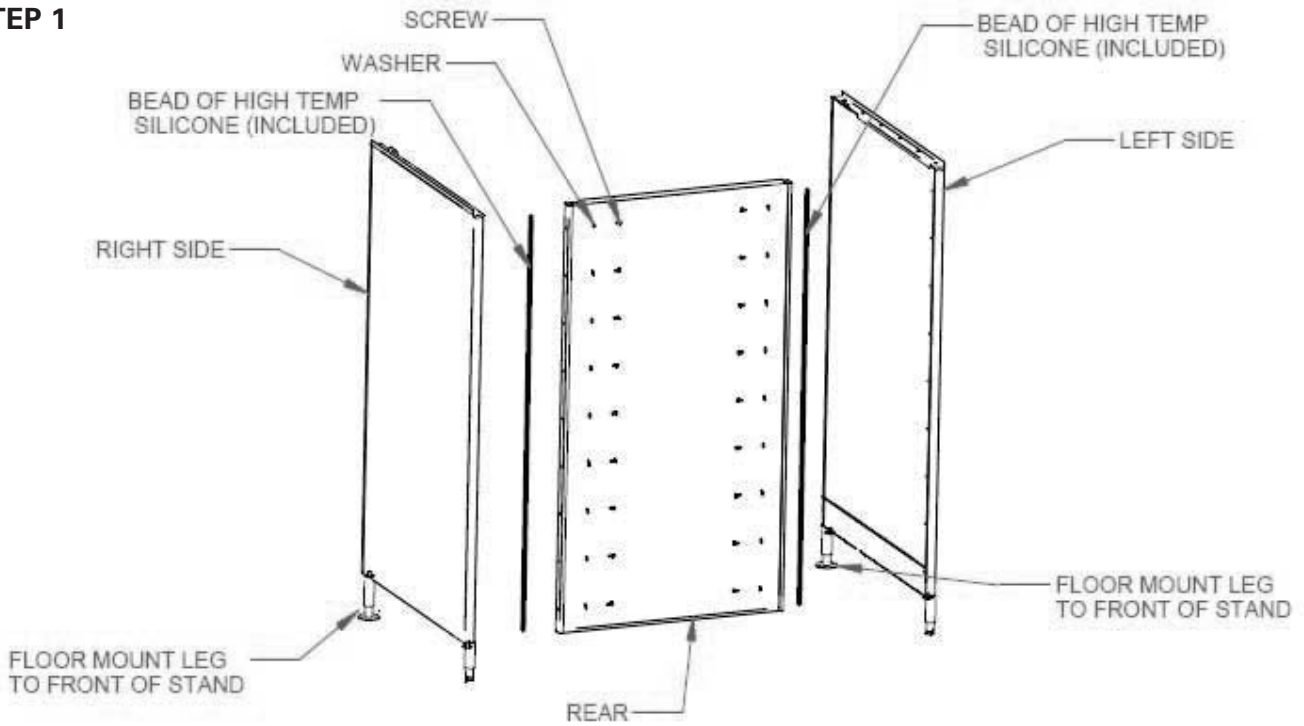

STEP 2

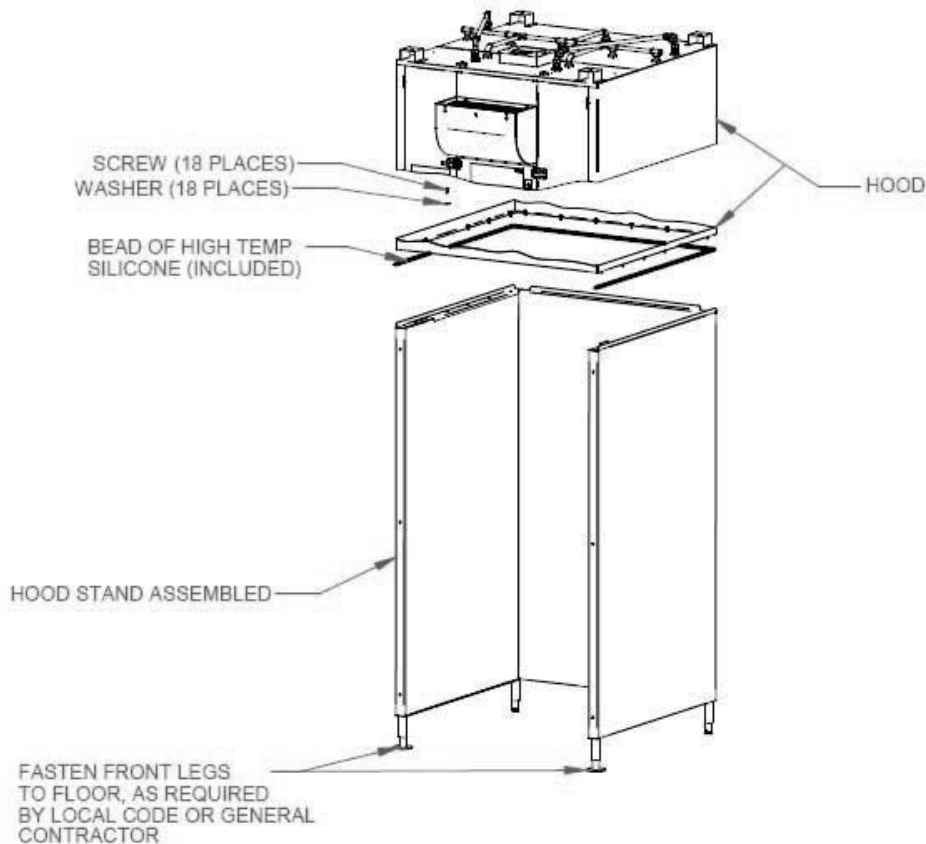

2-04. Cooking Appliance Limitations and Clearances

2-04.1. Fryer Limitations (Electric Appliances Only)

Hood	Max. Temp.	Max. kW Input	Max. Shortening Capacity	Max Cooking Surface (per Fryer)	Max Cooking Surface (Total all Fryers)
FSH-3.5 / 4	400	20(1)/40 Total	20 Gal.	576 Sq. In.	576 Sq. In.

2-04.2. Fryer Clearances (side-to-side overhang requirement does not apply with Free-standing Mount model)

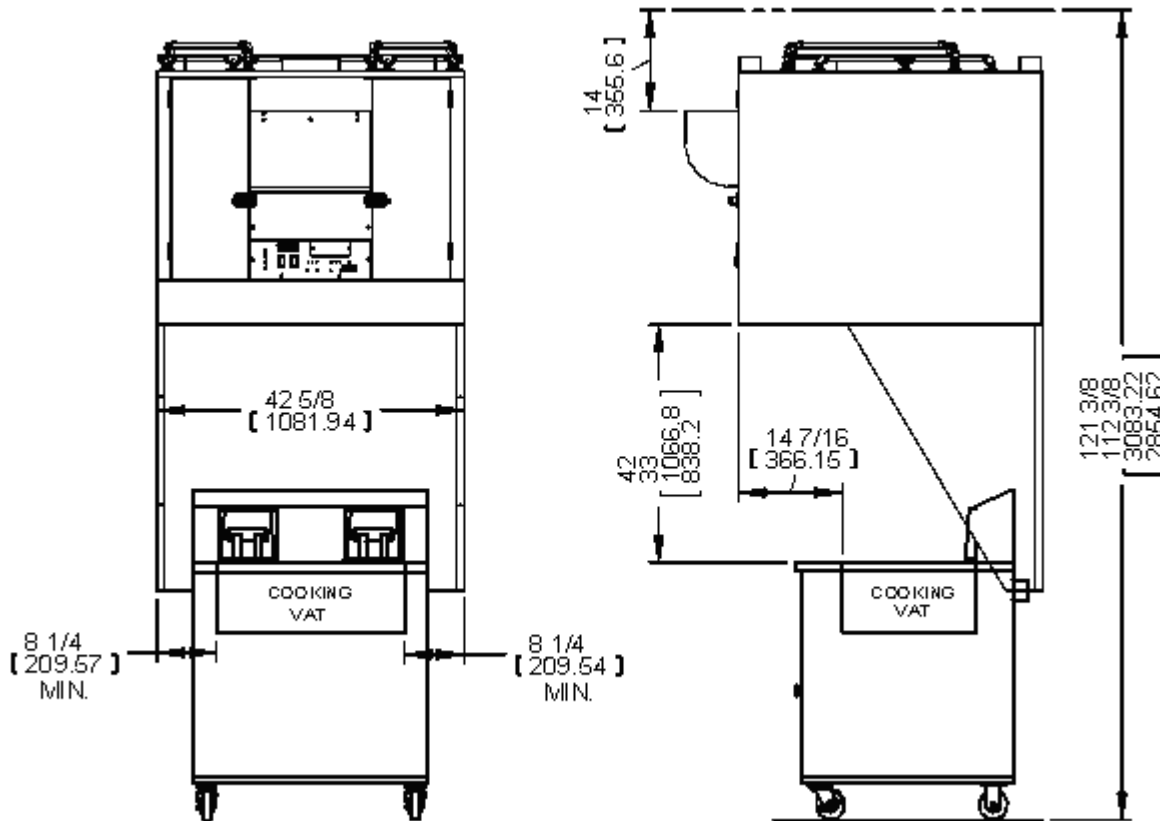

Inches [Millimeters]

2-04.3. Oven Limitations (Electric Appliances Only)

Hood	Max. Temp.	Max. kW Input (Total all Ovens)
FSH-3.5 / 4	500	55

2-04.4. Oven Clearances

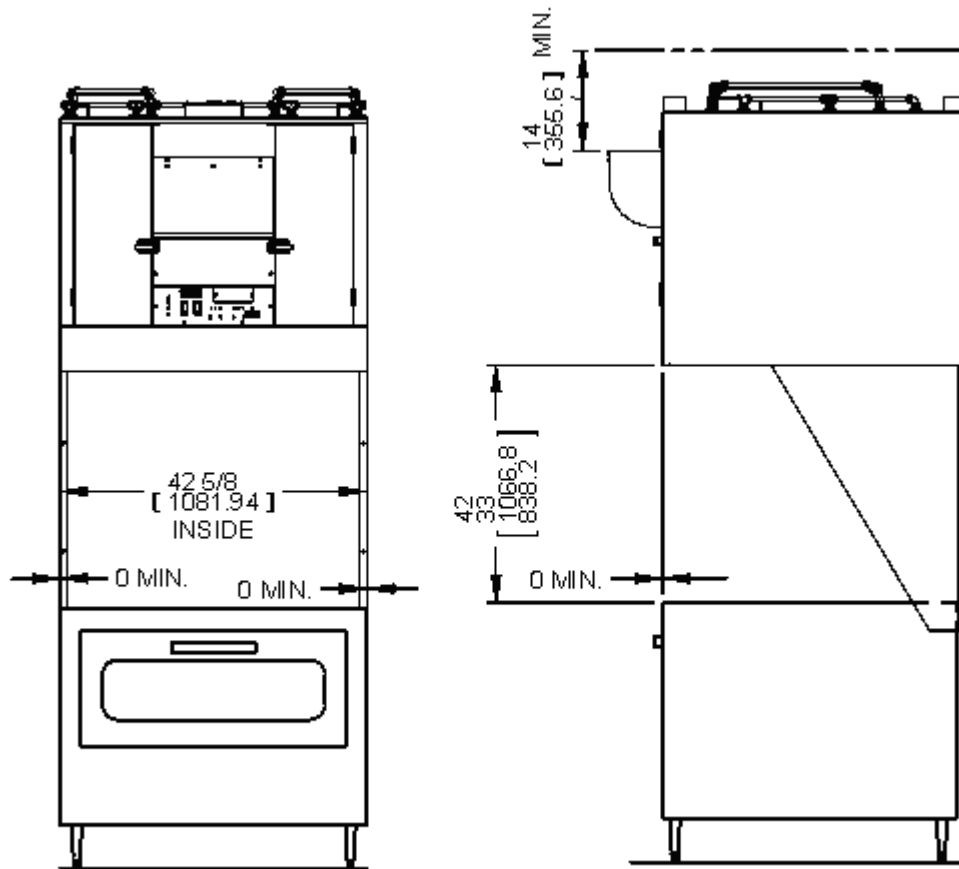

Inches [Millimeters]

2-04.5. Griddle Limitations (Electric Appliances Only)

Hood	Max. Temp.	Max. kW Input	Max Cooking Surface
FSH-3.5 / 4	400	25	42 X 42

2-04.6. Griddle Clearances (side-to-side overhang requirement does not apply with Free-standing Mount model)

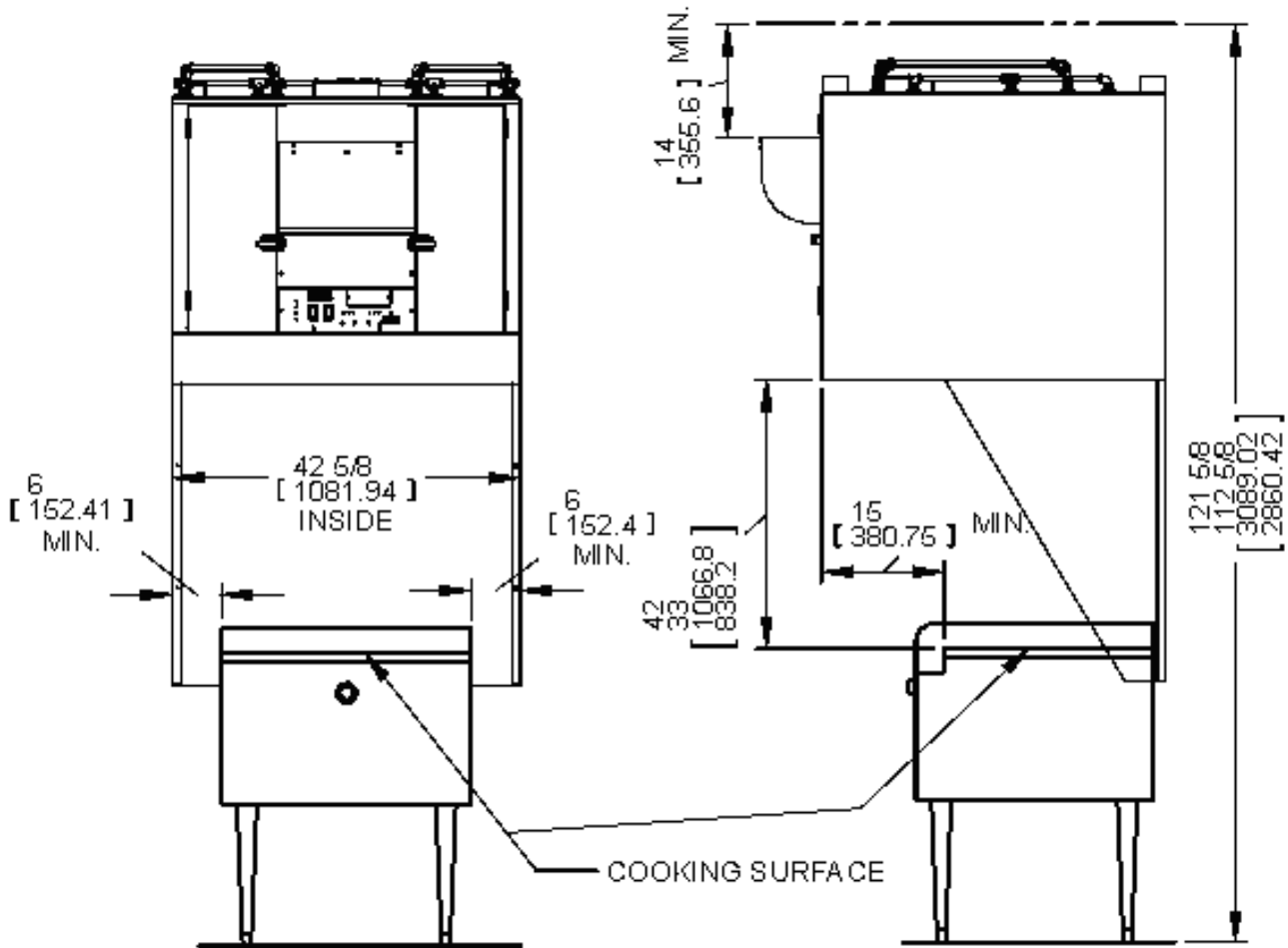

Inches [Millimeters]

2-04.7. Range Limitations (Electric Appliances Only)

Hood	Max. Temp.	Max. kW Input	Max Burners
FSH-3.5 / 4	400	25	8

2-04.8. Range Clearances (side-to-side overhang requirement does not apply with Free-standing Mount model)

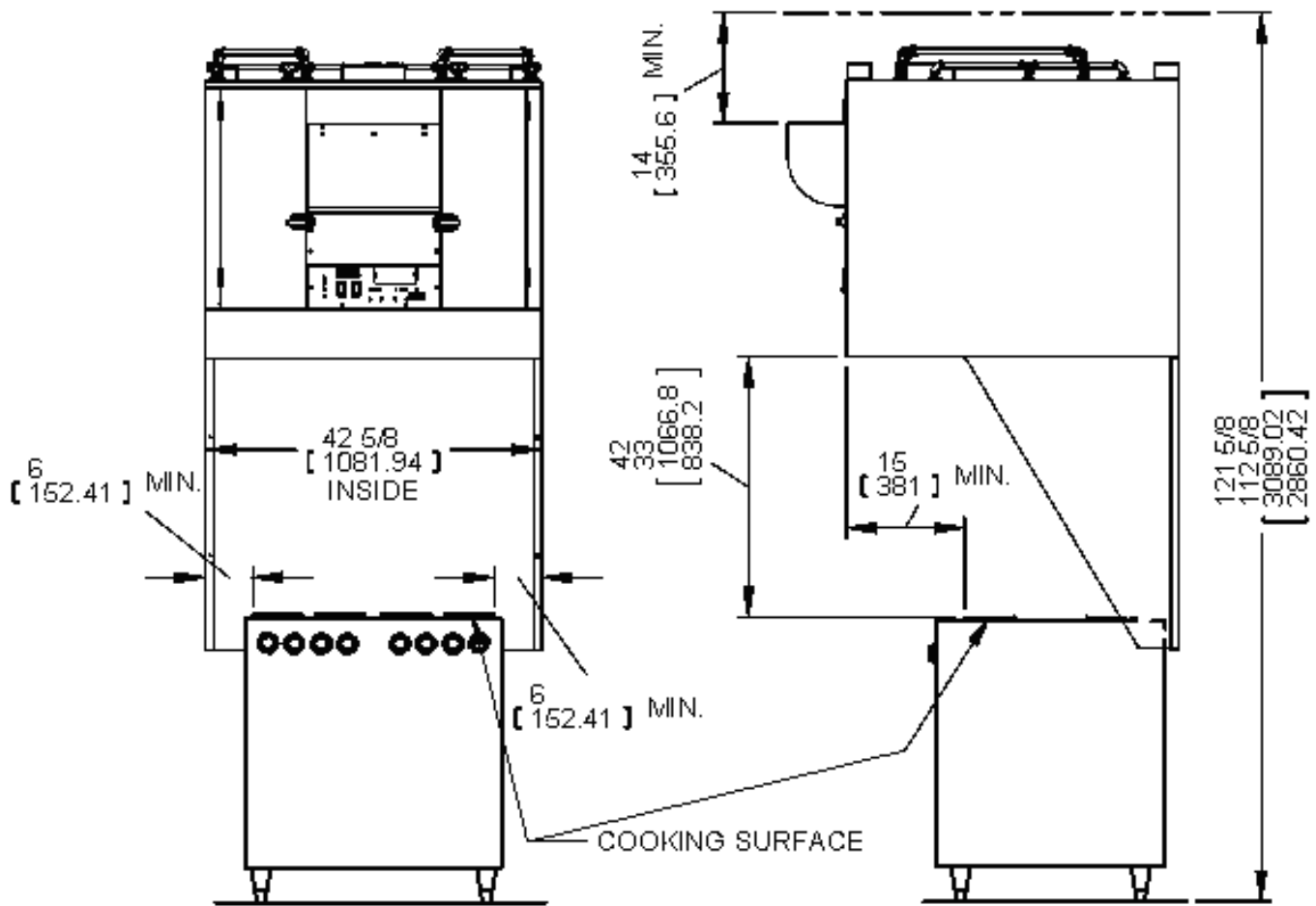

Inches [Millimeters]

2-05. Hood Electrical Requirements

⚠ WARNING

- Consult a qualified electrician to ensure all electrical specifications have been met and that the unit is properly grounded.
- Improper installation, adjustment, alteration, service or maintenance could result in death or serious injury, equipment/property damage, and void the warranty.

Hood Electrical Requirements

Unit	Voltage	Hz	Phase	Amps	Breaker
FSH-3.5 & 4	208 or 240	60	1	15	20

2-05.1. Electrical Connections

1. Install appropriate Circuit Breaker in Main Breaker Box (See Section 2-05).
2. Connect appropriate size wire from hood to the main breaker.
3. Re-install Service Panel.
4. Turn Main Breaker on.
5. Press the Hood power switch to the **ON** position. If ILS, press and hold the “Push to Start” button for 5 secs after power is on.

2-05.2 Routing Power Wires

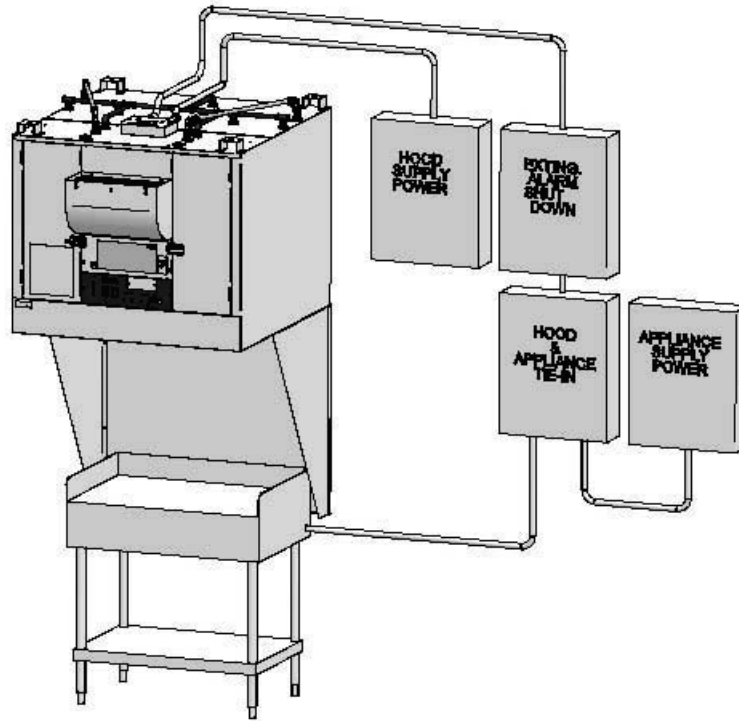

2-05.3 Hood and Appliance Interlock Diagram

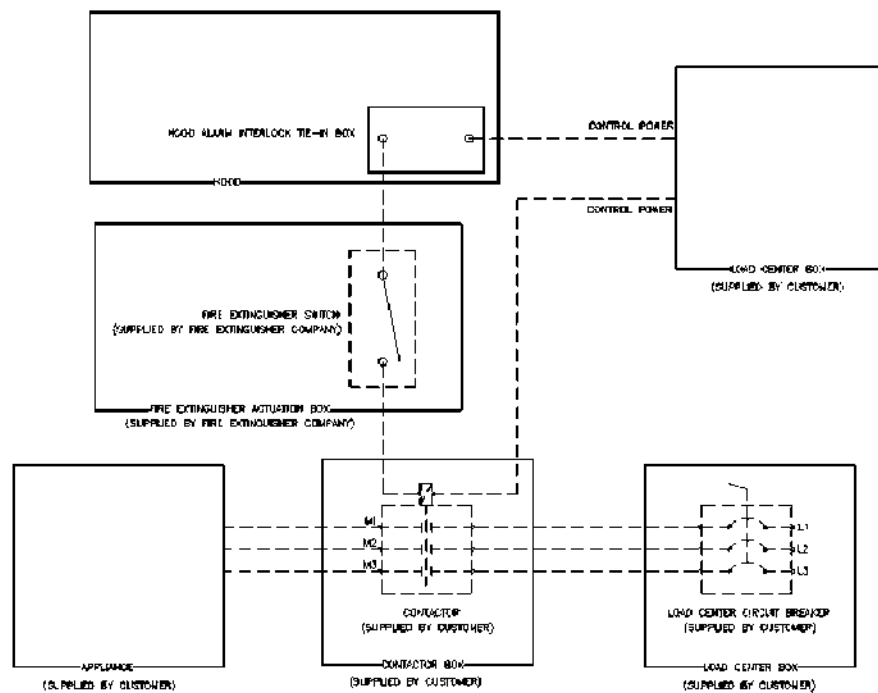

2-06. Fire Suppression System Installation

It is a requirement that the Giles FSH-3.5/4 Ventless Hood System be protected by a UL Listed fire suppression system. Installation must be performed by an Authorized Fire Suppression Agent in accordance with the system listing.

The FSH-3.5/4 hood system is pre-piped at the factory and contains supply line, plenum nozzles and fusible link brackets. **Appliance nozzles and drop-downs are not included.** The hood has been designed to accommodate either left or right side hook-up. The electrical switch requirements are identical to those listed in the Ansul R-102 Installation Manual with the hood system acting as the customer supplied switch.

1. Use Ansul No. 56922-1W Appliance Nozzles, No. 56927 Plenum Nozzles and Ansul No. 56811 Fusible Link 165°F (74°C).
2. Appliance nozzles shall be positioned 11" [279.4mm] below the lowermost front edge of the hood.
3. The use of both appliance nozzles is required at all times.
4. A manual pull station for the Fire System is to be installed and located in a path of exit or egress. The pull station must be clearly marked and easily accessible.
5. Regulated Release Assembly shall be the mechanical type (Ansul P/N 79290).

2-06.1. Fire Suppression System Routing

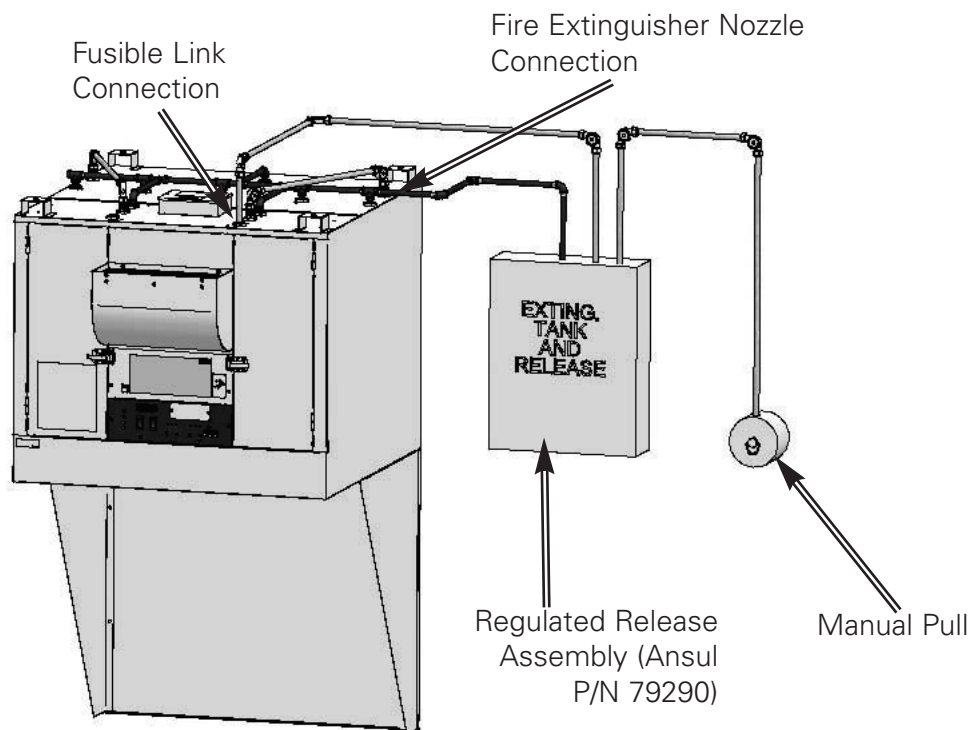

Note -System may be located and connected on the left or right of the hood.

2-06.2. Fire Suppression Fusible Links

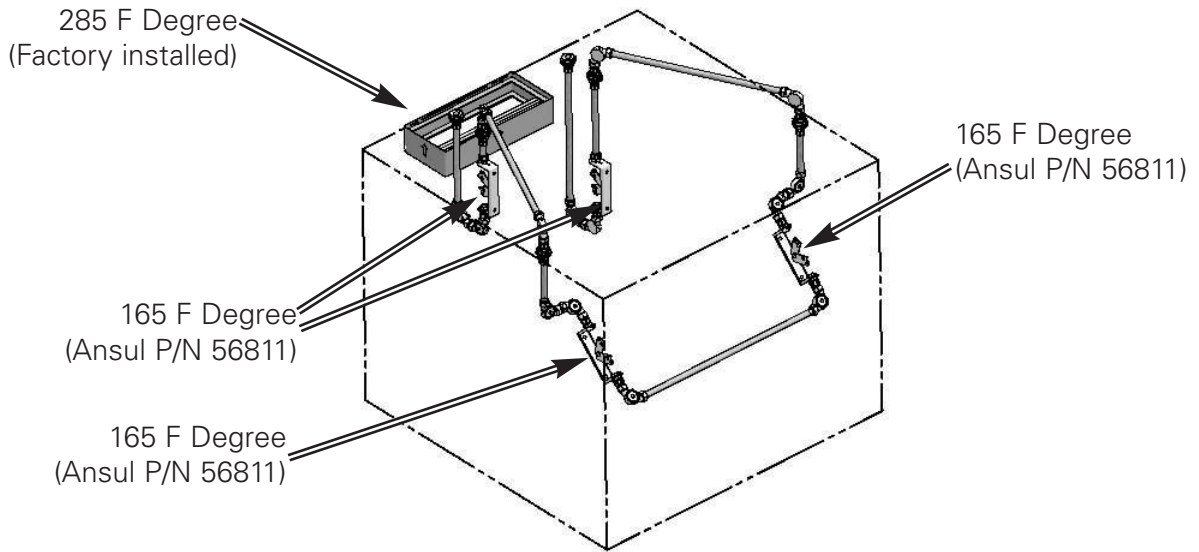

2-06.3. Appliance Nozzles

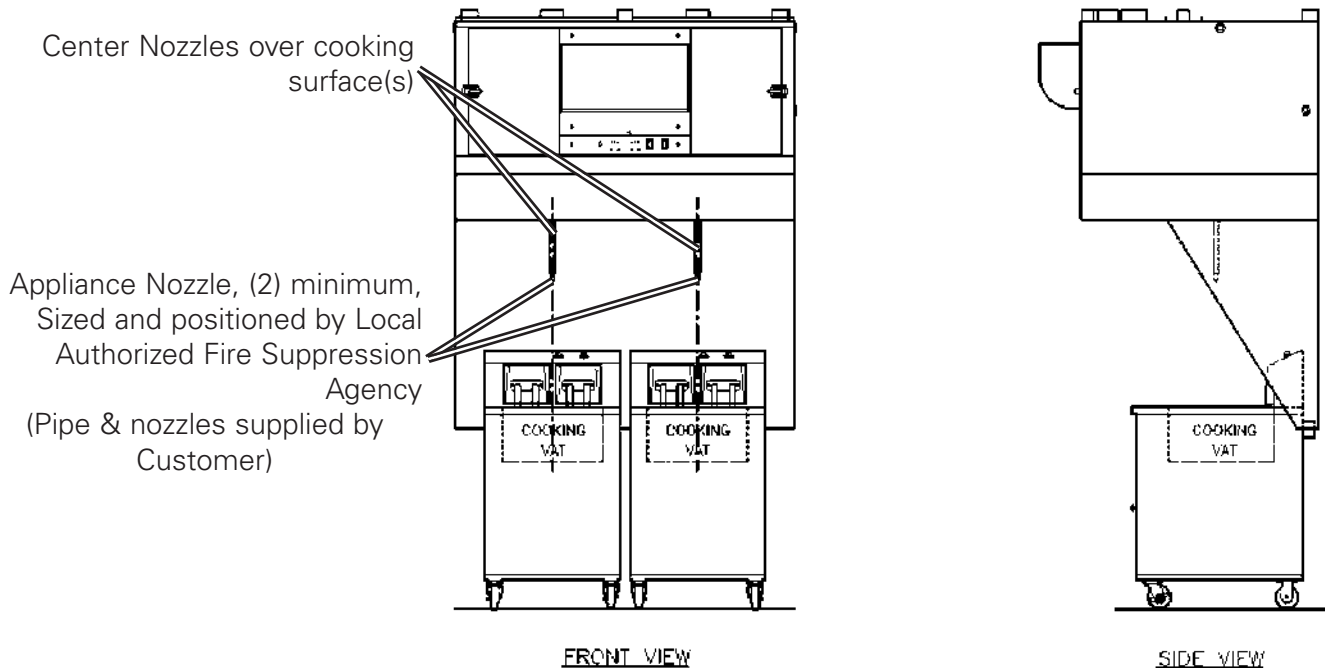

2-06.4. Fire Extinguisher Nozzle Locations

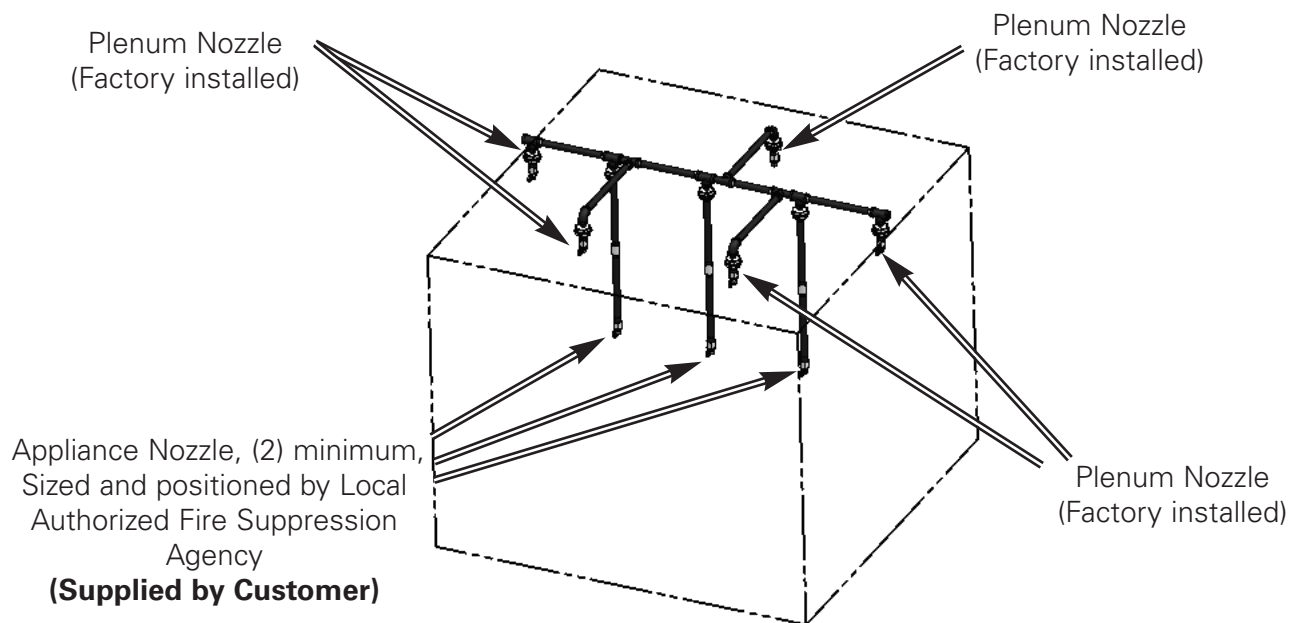

2-06.5. General Maintenance

The fire extinguishing system should be maintained as outlined in the Standard for Wet Chemical Extinguishing Systems, NFPA 17A and in accordance with the instructions of the system's installer. Please contact a local Authorized Fire Suppression Agent or Ansul Dealer for maintenance, troubleshooting and repairs.

General Maintenance of the fire suppression system is very important. Inspect and maintain as follows: Servicing and inspection of the fire suppression system is to be conducted by qualified fire protection technicians. As a minimum, field inspection of the fire suppression system is to be performed semi-annually. Such maintenance shall consist of the following:

1. Confirm that the hazard has not changed.
2. Verify that system pressure is nominal.
3. Inspect the soundness of the discharge spray nozzles and fusible links.
4. Ensure the system is properly located with respect to the appliance.
5. Verify the date the unit was manufactured.
6. Check to be sure the service tag is attached indicating what service was performed and when performed.

*Ansul is a registered trademark.



NOTES:

3. Overview

The following section provides a brief overview of the components, functions, and accessories of the FSH-3.5/FSH-4 Series hood. Please review this section carefully before proceeding any further.

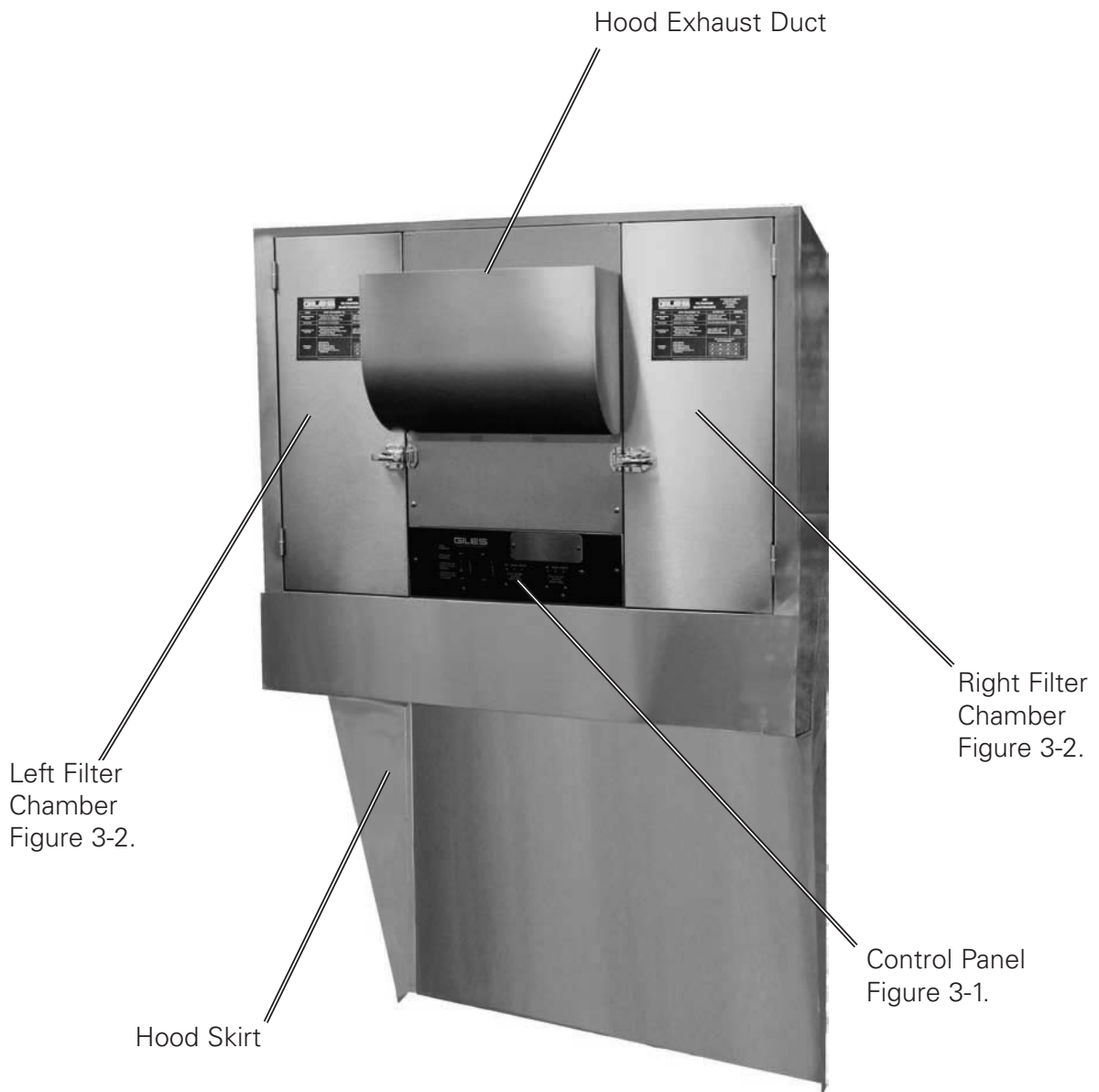

3-01. Control Panel

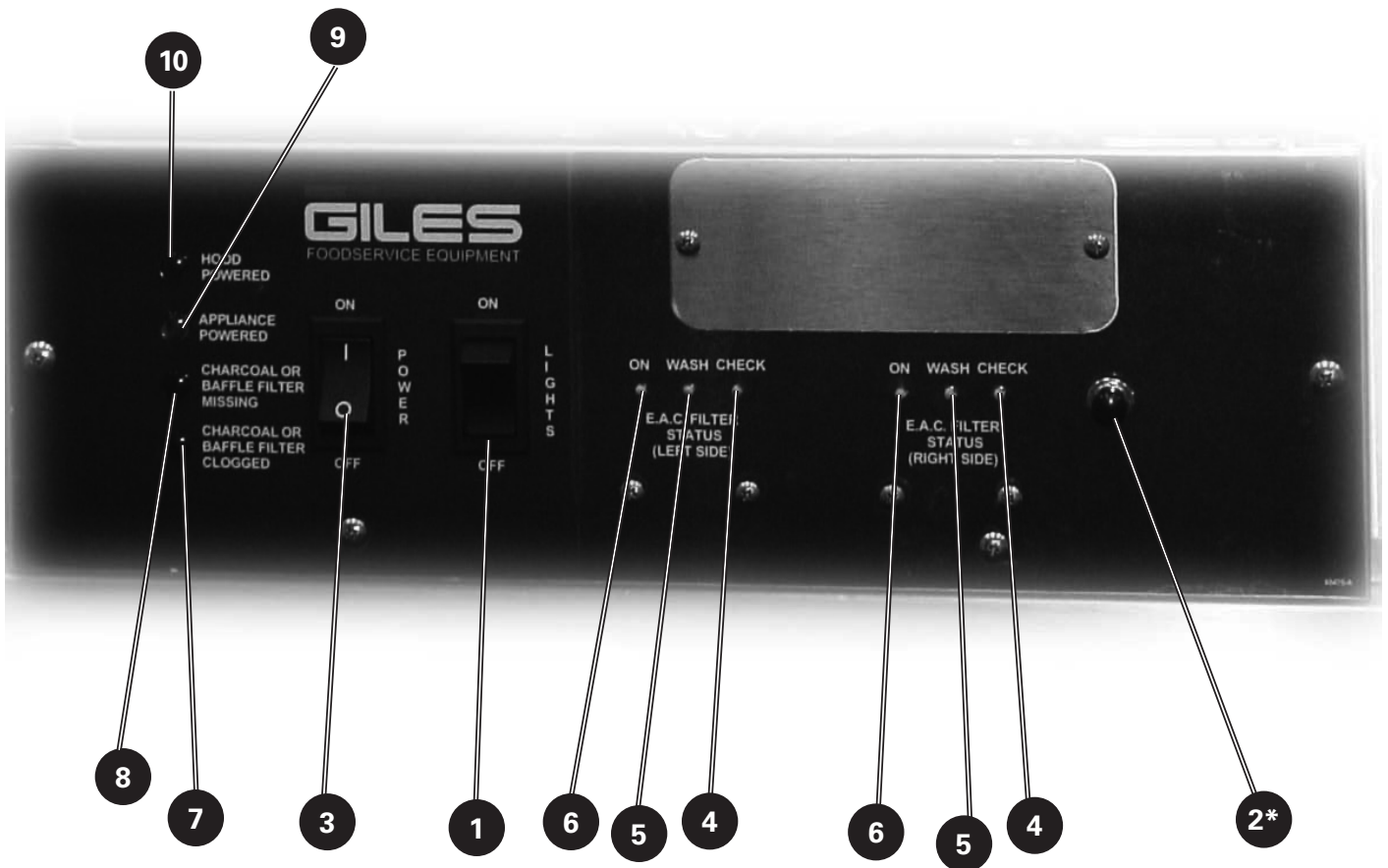

* ILS Only

3-01. Control Panel		
Item	Description	Function
1	Light Switch	Used to turn the hood light on and off.
2*	PUSH to START Button	After the Power Switch is in the "ON" position, push and hold down "PUSH to START" Button for 5 seconds. (Used only in units with Inter-Locking Start (ILS) system.
3	Power Switch	The Power Switch is a two-position Switch. Move the switch upward to the "ON" position for operation.
4	"CHECK" LED Indicator (Right & Left EAC's)	The "Check" Indicator Light will turn on when the EAC becomes shorted. (EAC needs cleaning or repair).
5	"WASH" LED Indicator (Right & Left EAC's)	The "Wash" Indicator Light will come on when the EAC becomes excessively dirty. DO NOT use this light as a signal for routine cleaning of the EAC. Failure to clean the EAC daily will significantly decrease the life of the charcoal filter and possibly damage the EAC power supply. Clean the EAC daily for best performance.
6	"ON" LED Indicator (Right & Left EAC's)	The "ON" Indicator Light will turn on when the Electronic Air Cleaner (EAC) power supply is on.
7	Charcoal or Baffle Filter Clogged Light	The "Charcoal or Baffle Filter Clogged" Light will turn on when the Grease Baffle Filter, Pre-filter, or Charcoal Filter is dirty/clogged.
8	Charcoal or Baffle Filter Missing Light	The "Charcoal or Baffle Filter Missing Light" illuminates when either Charcoal, Pre-Filter, or Baffle filter is missing or incorrectly installed.
9	Appliance Powered Light	The "Appliance Powered Light" will turn on to signify appliance power when all filters are installed correctly and none are clogged.
10	Hood Powered Light	The "Hood Powered Light" will turn on when both of the filter doors are closed properly and power switch is "on." If equipped, ILS button must also be depressed.

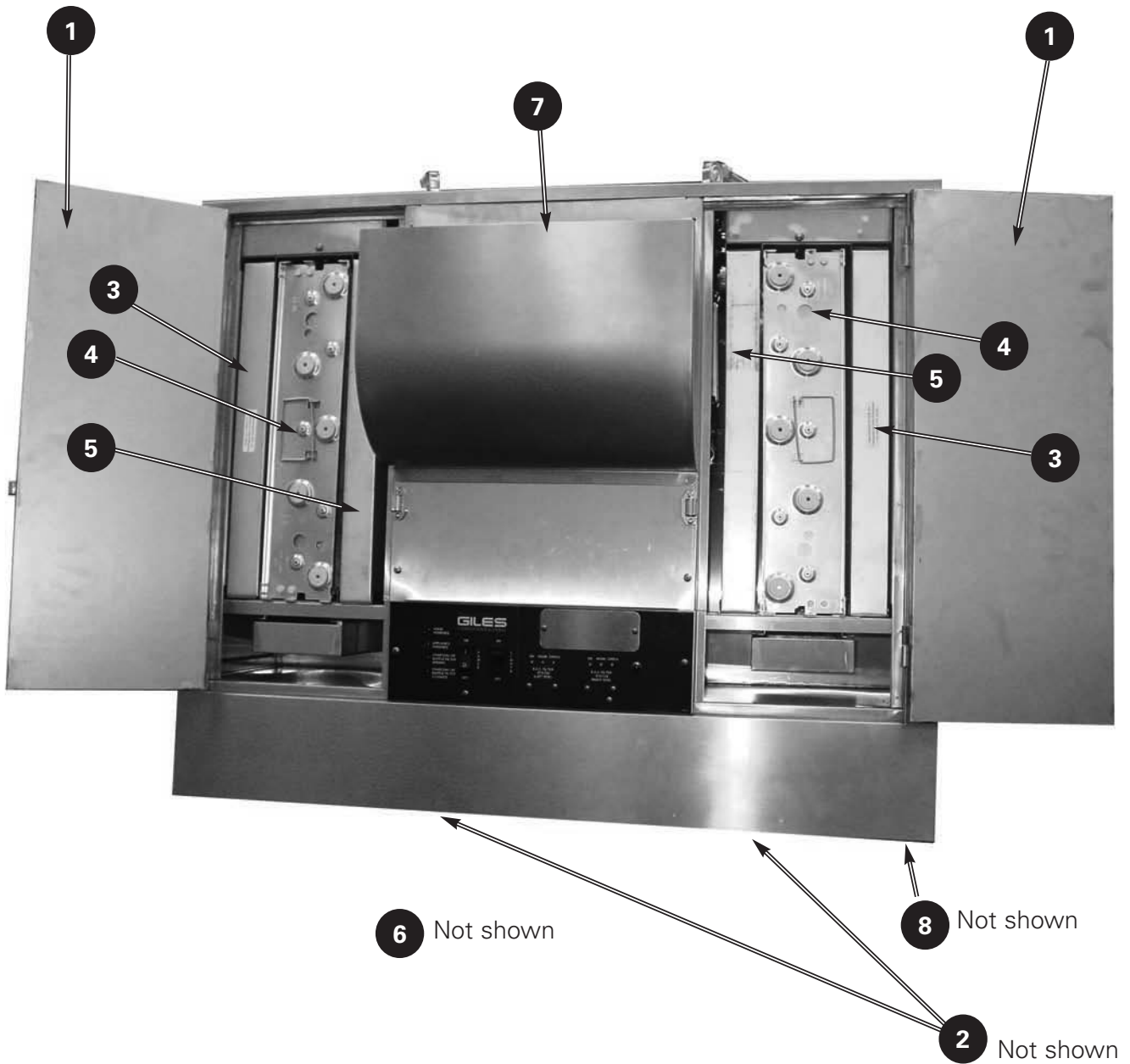

3-02. Filter Chamber and Exhaust



3-02. Filter Chamber and Exhaust



Item	Description	Function
1	(2) Hood Filter Door	Used to access the Pre-Filter, EAC and Charcoal Filters. The door must be closed and latched for the unit to operate.
2	(2) Baffle Filter	Baffle Filters are the first stage of the grease extraction and air-cleaning system of this unit. These filters are easily removed for daily cleaning. To prevent contact with electrical parts and avoid electrical shock, DO NOT remove the Baffle Filter(s) while the hood is operating. The Baffle Filter should be cleaned daily.
3	(2) Pre-Filter	Pre-Filters remove additional grease-laden vapors from the air stream. To prevent contact with electrical parts and avoid electrical shock, DO NOT remove the Pre-Filter(s) while the hood is operating. NEVER attempt to clean and re-use the Pre-Filters ... Replace with new filters weekly.
4	EAC Filter (Left and Right)	EAC Filters are electrostatic devices that remove grease vapor and smoke generated by the appliance during cooking. To prevent contact with electrical parts and avoid electrical shock, DO NOT remove the EAC Filter while the hood is operating ... The EAC should be cleaned daily.
5	(2) Charcoal Filter	Charcoal Filter helps to eliminate cooking odors. These Filters should be replaced monthly. To prevent contact with electrical parts and avoid electrical shock, DO NOT remove the Charcoal Filter while the hood is operating. NEVER attempt to clean and re-use the Charcoal Filters ... Replace with new filters every 30 days.
6*	Hood Skirt	The Hood Skirt helps contain and capture grease laden vapors produced by the cooking appliance.
7*	Exhaust Outlet	The Exhaust Outlet located on front of the unit, exhausts the filtered air back into the room. A minimum clearance of 14" must be maintained between the top of the Exhaust Outlet and the Ceiling, or other obstruction, for proper air flow.
8*	Grease Drip Cup	The Grease Drip Cup is used to catch grease condensate generated at the Baffle Filters. This cup must be emptied and cleaned daily.

* Not shown

3-03. Accessories (Included)		
Part	Description/Part Number	Function
	<p>(2) Baffle Filter P/N 40943</p>	<p>Removes large particle contaminant from the air.</p>
	<p>(2) Pre-Filter P/N 91707</p>	<p>Removes additional grease-laden vapors from the air.</p>
	<p>EAC Filter P/N 20521 (LEFT) P/N 20520 (RIGHT)</p>	<p>Removes smoke and small particle contaminant from the air.</p>

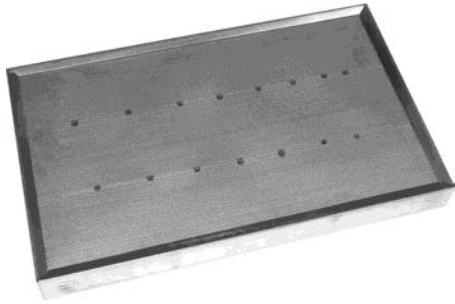

3-03. Accessories (Included)

Part	Description/Part Number	Function
 A rectangular charcoal filter with a mesh-like surface and several small circular holes along its length.	(2) Charcoal Filter P/N 31964	Helps remove odors from the air
 A rectangular metal tank with a lid, used for soaking and cleaning the EAC filter.	EAC Soak Tank P/N 39327	Used for soaking and cleaning EAC filter.



Notes:

4. Operation & Filter Maintenance

This section describes Hood operation and filter maintenance.

4-01. Hood Operation

Starting the Ventless Hood ... Make sure all Filters are in place and filter access doors are closed before attempting to operate the unit. **NOTE: The hood will NOT power-up if either filter door is open.**

- Place the Power Switch **1** to the **ON** position, (if ILS model, press and hold the "Push & Hold to Start" Button **2** for 5 seconds). The EAC **ON** light **3** will illuminate and the "Appliance Powered" light **5** will turn **ON**.
The cooking appliance under the hood, which is interlocked with the hood may now be turned on.
- Press the Light Switch **4** to the **ON** position to turn on the under-hood lights.

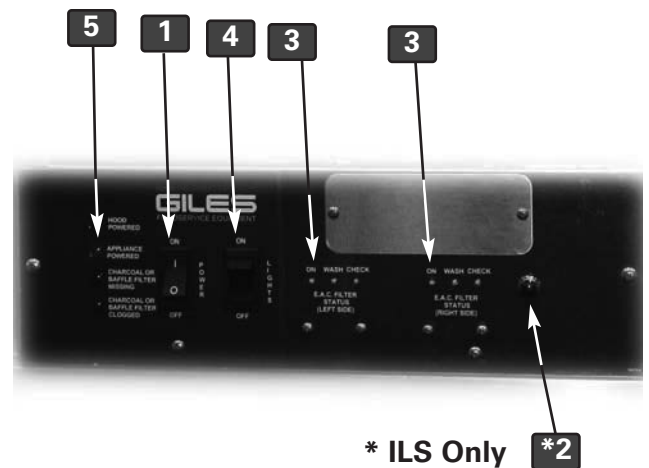

4-02. Filters and Filter Maintenance

Filter System operation, cleaning and maintenance schedule

4-02.01. Ventless Hood Filter Table

Filter	When to clean or replace	How to remove	How to clean	How to install
Baffle Filter	Clean daily	Section 4-02.02.	Section 4-02.05.	Section 4-02.03.
Pre-Filter	Replace weekly	Section 4-02.06.	Never clean, Replace Only Section 4-02.09.	Section 4-02.07.
EAC Filter	Clean daily	Section 4-02.10.	Section 4-02.13.	Section 4-02.11.
Charcoal Filter	Replace every 30 days	Section 4-02.14.	Never clean, Replace Only Section 4-02.17.	Section 4-02.15.
Ultra Violet Lamp (If equipped)	Clean every 30 days Replace annually	Section 4-02.19	Section 4-02.18	Section 4-02.20

4-02.02. Baffle Filter Removal



1 Place in OFF position

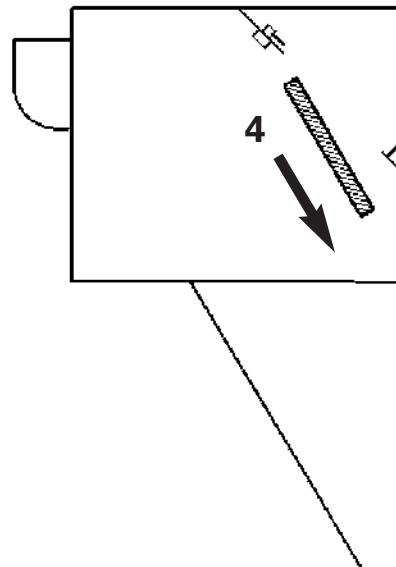
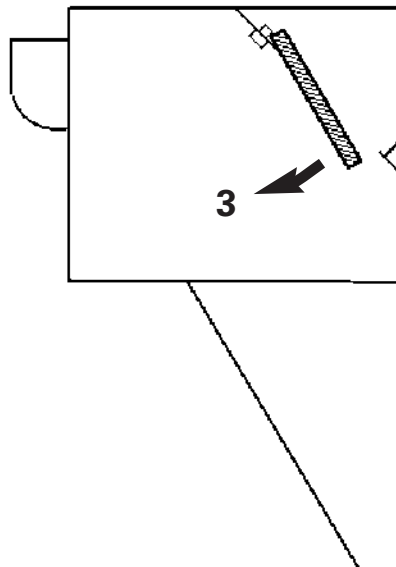
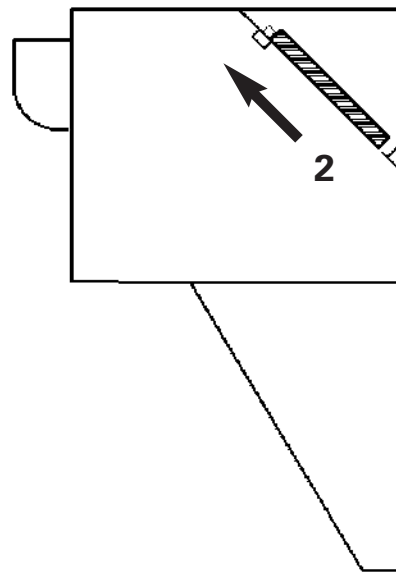
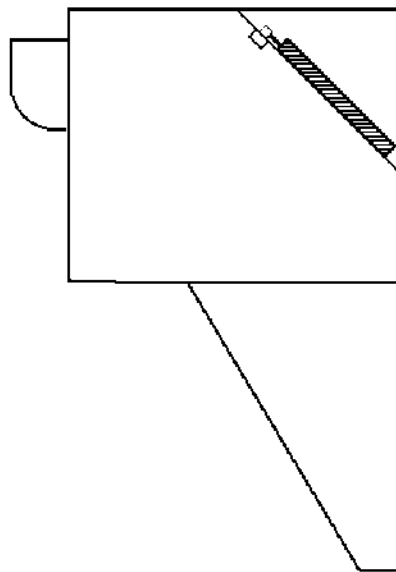

4-02.03. Baffle Filter Installation

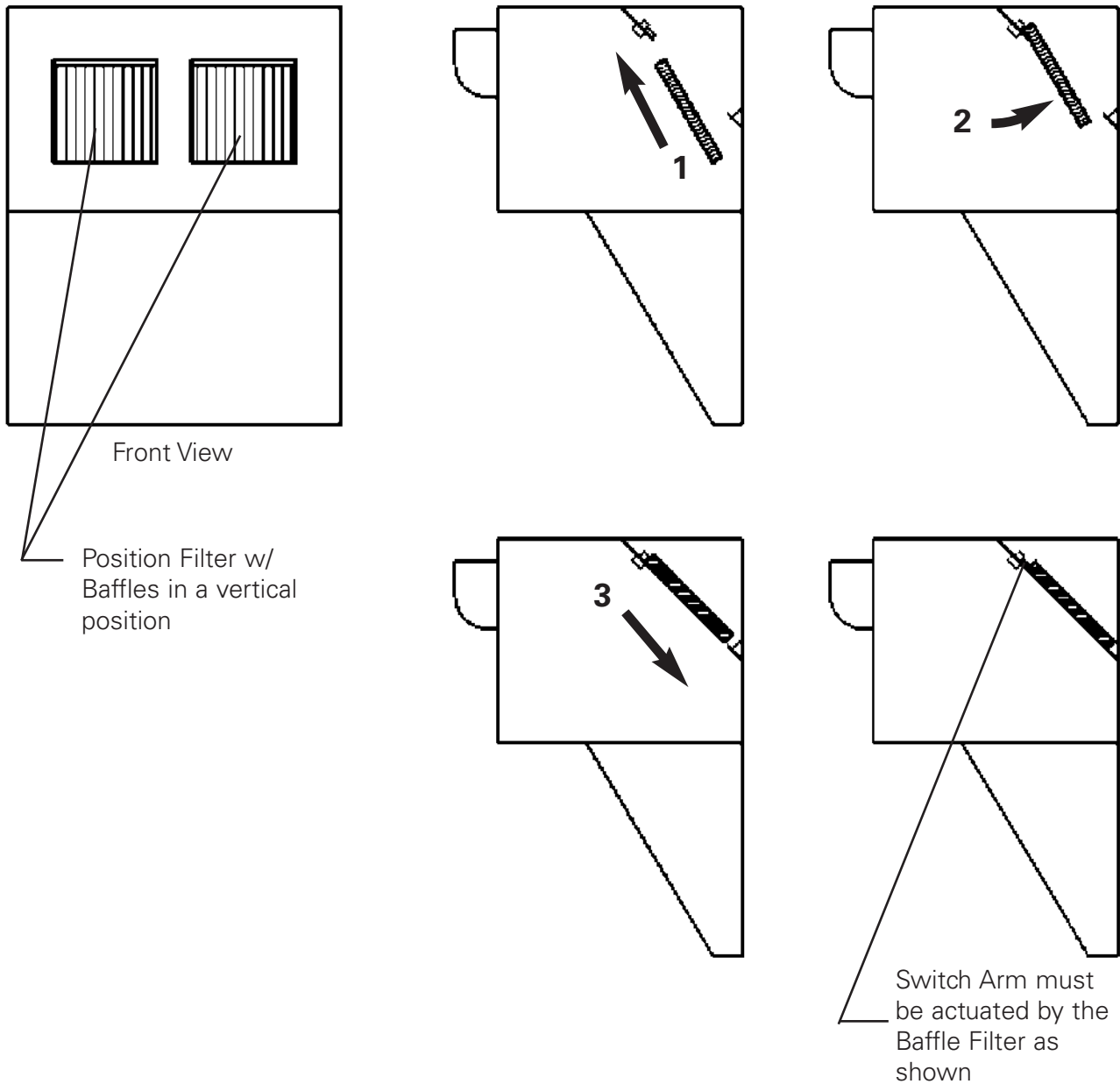

4-02.04. Baffle Filter Missing

If either Baffle Filter is missing, or not positioned correctly, the Filter Missing Light **1** will illuminate and power to cooking appliance is interrupted until the condition is corrected (Appliance Powered light will turn **OFF**). See Section 4-2.03 Baffle Filter Installation.



4-02.05. Baffle Filter Cleaning

Grease Baffle Filters should be cleaned daily. Place them in sink and clean with a mild bio-degradable degreaser. Dry filters thoroughly and reinstall in the unit.

4-02.06. Pre-Filter Removal



1 Place in OFF position

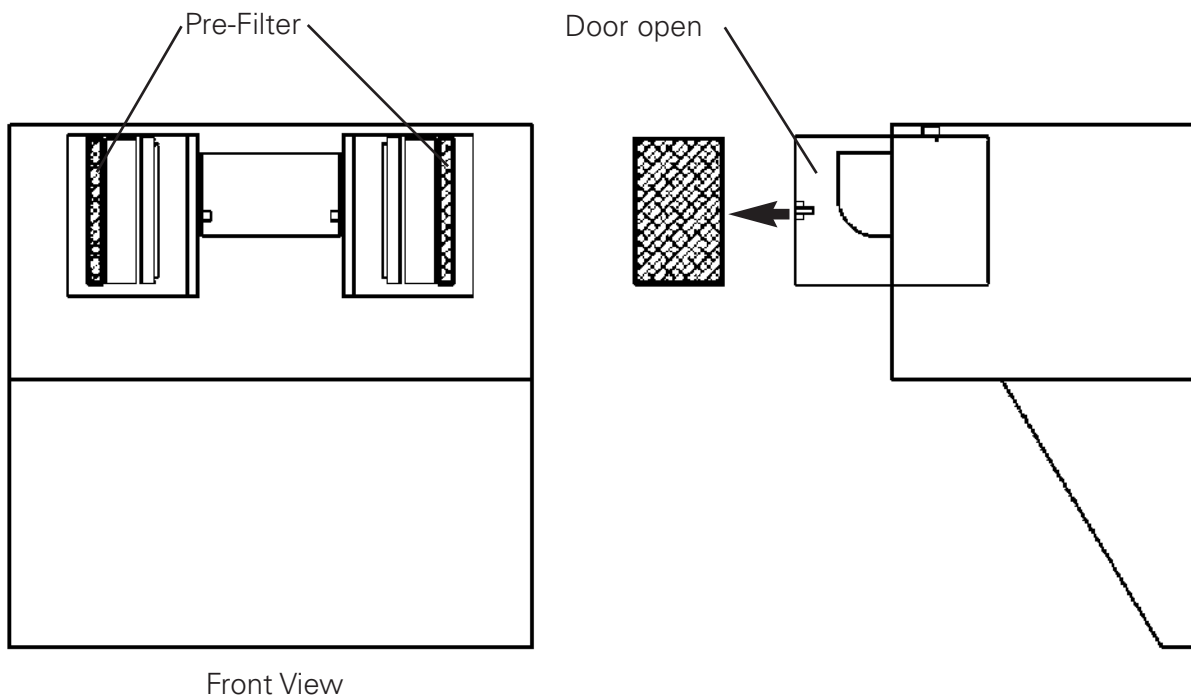

4-02.07. Pre-Filter Installation

NOTE:

- When filters are changed, always record the installation date in the space provided on the filter label.

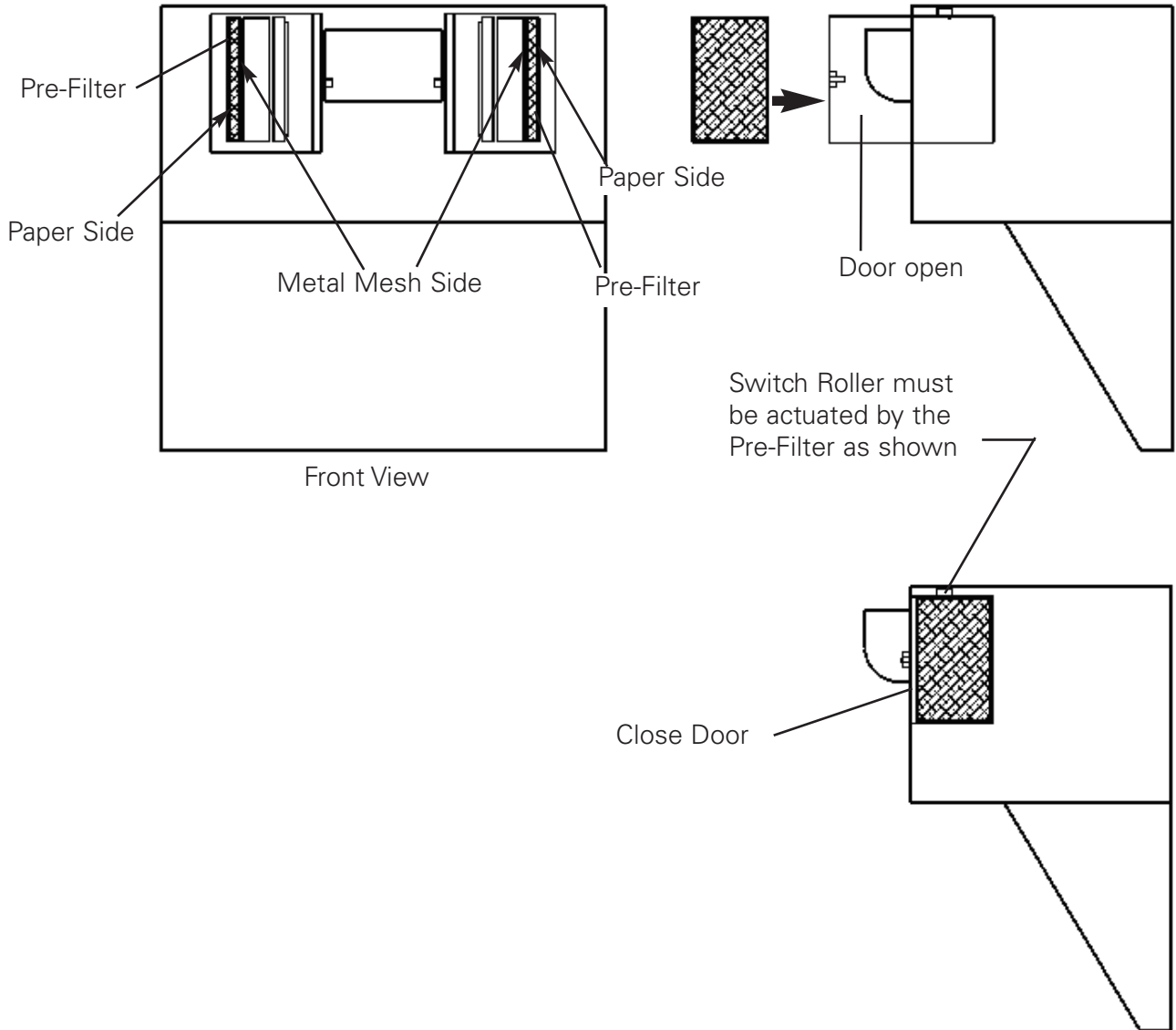

4-02.08. Pre-Filter Filter Missing

If either Pre-Filter is missing or not properly positioned, the Filter Missing Light **1** will illuminate and power to cooking appliance is interrupted until the condition is corrected (Appliance Powered light will turn **OFF**).
Section 4-02.07 Pre-Filter Installation.



4-02.09. Pre-Filter Replacement



- NEVER attempt to clean and re-use the Pre-Filter. This could damage the unit.

Replace Pre-Filters weekly ... **Replacement Part No. 91707.**

4-02.10. EAC Filter Removal



1 Place in OFF position

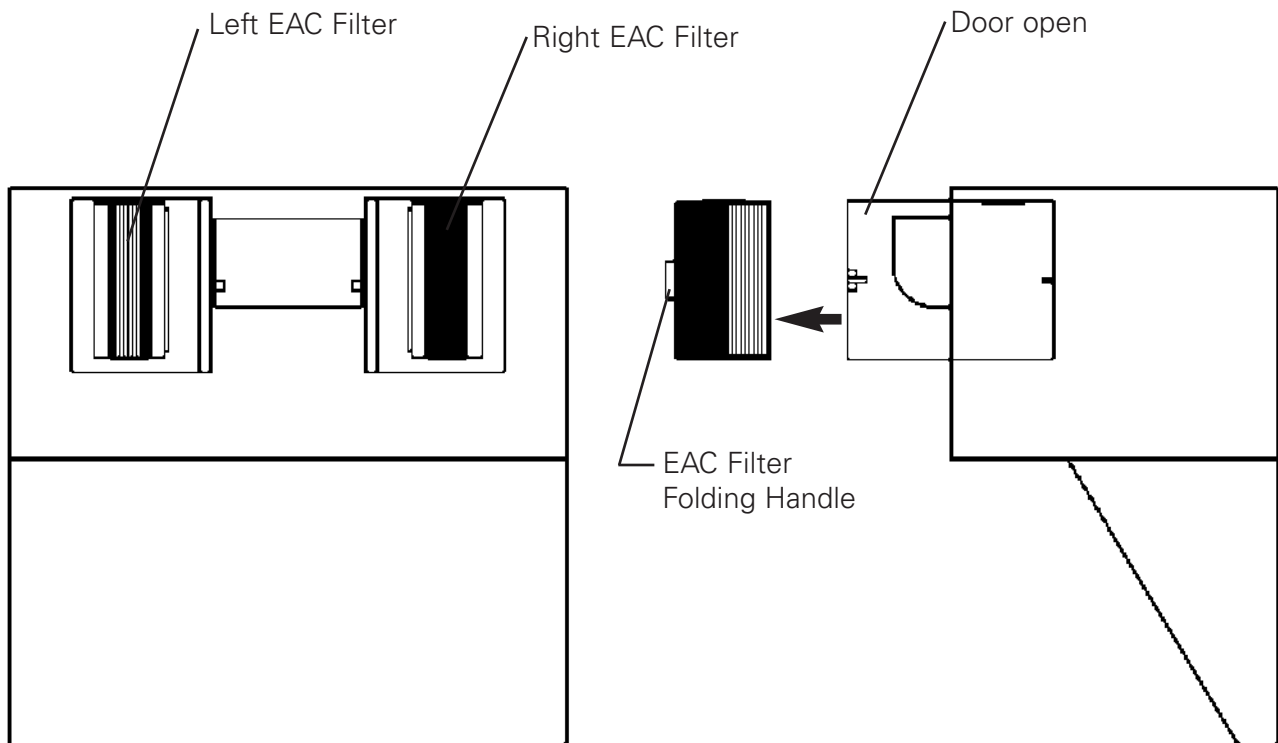

4-02.11. EAC Filter Installation

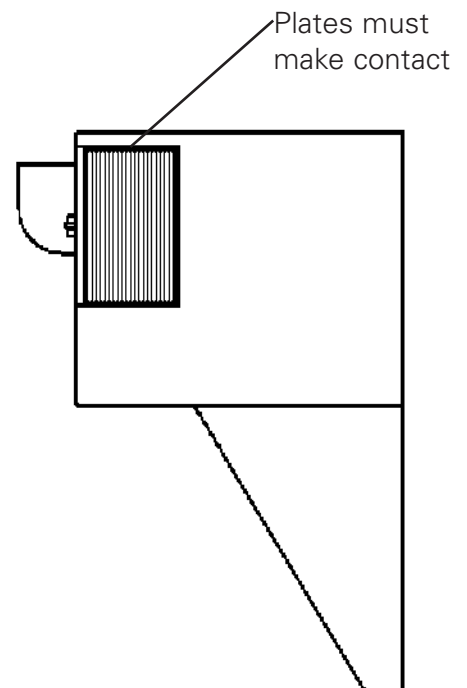
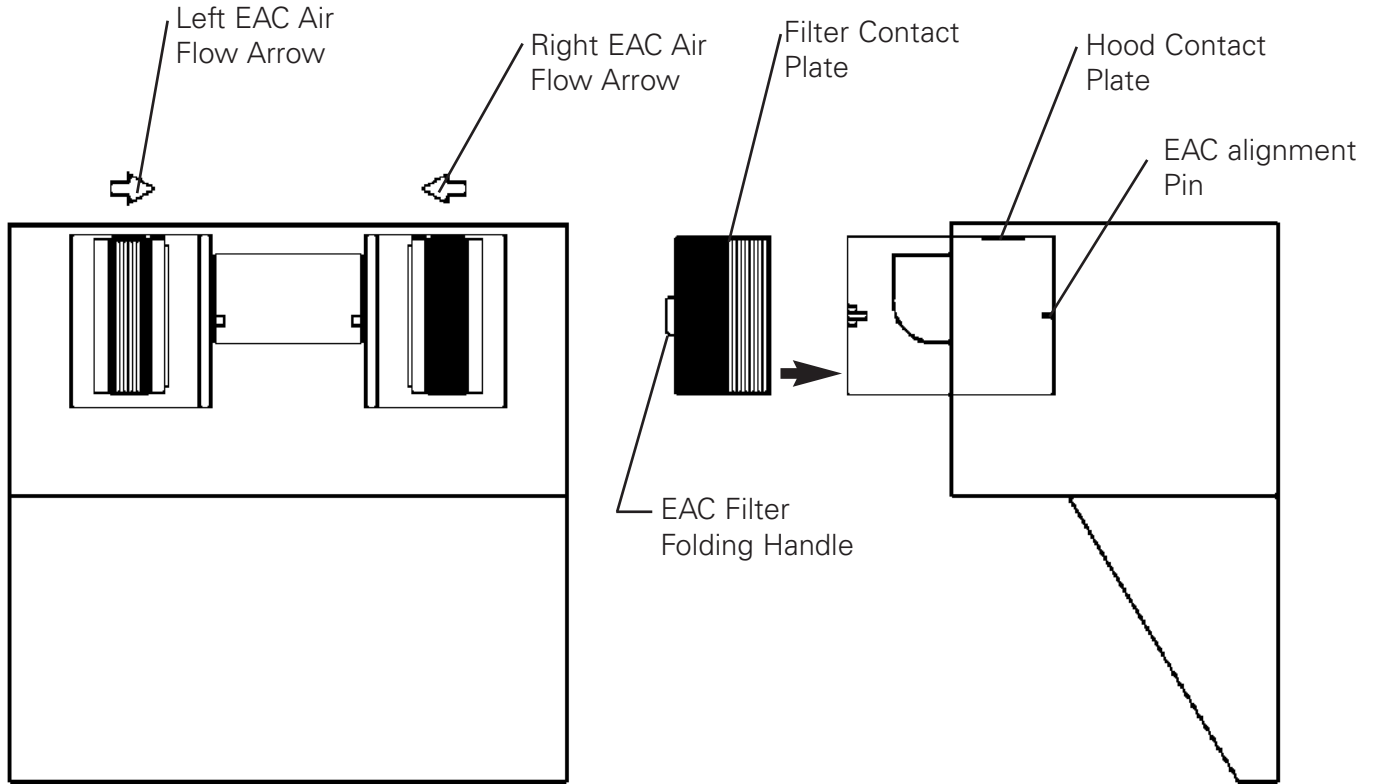

If either EAC Filter is missing or not properly positioned, all 3 EAC LED's **1** will illuminate and after approx. 2 minutes an intermittent tone alarm will sound. "Appliance Powered" light will turn **OFF** and power to interlocked under-hood cooking appliance(s) is interrupted until the condition is corrected

4-02.12. EAC Filter Status

Three LED indicator lights on the Control Panel display the status of each EAC Filter.

- 1 ON** The EAC Filter is in place, powered and operating properly..
- 2 WASH** When **ON**, indicates the collection fins are becoming excessively dirty and must be cleaned. After approx. 2 minutes in this condition, an intermittent tone alarm will sound and power to interlocked under-hood cooking appliance(s) will be interrupted until the condition is corrected. The "Appliance Powered" light will turn **OFF**.
- 3 CHECK** When **ON**, indicates the Filter is not operating. There is either a poor connection at the contacts or the filter is damaged. After approx. 2 minutes in this condition, an intermittent tone alarm will sound and power to interlocked under-hood cooking appliance(s) will be interrupted until the condition is corrected. The "Appliance Powered" light will turn **OFF**.

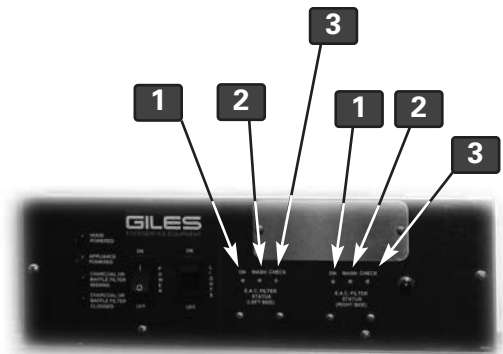

4-02.13. EAC Filter Cleaning

The EAC Filter should be cleaned daily.

CAUTION

- **Do not bend the fins or break the ionizer wires on the EAC as this will prevent the electrostatic collecting cell from performing properly and potentially void the warranty.**

1. Add 1/2 gal of a mild degreaser, such as "Simple Green" or "Clean Magic," to the Soak Tank **1** ... add water to fill line (X's) and mix.
2. Holding the cell by the contact plate **2**, carefully lower the EAC **3** into the mixed degreasing solution.
3. Allow the EAC to soak for 20 to 30 minutes. Grasping it by the contact plate **2**, lift and agitate vigorously up and down in the solution several times to dislodge grease residue.
4. Carefully remove the EAC from the tank and rinse thoroughly in a sink using hot water.
5. Allow the cell to air dry, thoroughly.
6. Inspect cell for broken wires or bent fins, Have broken wires replaced promptly. Bent fins may be gently straightened by hand, if needed.

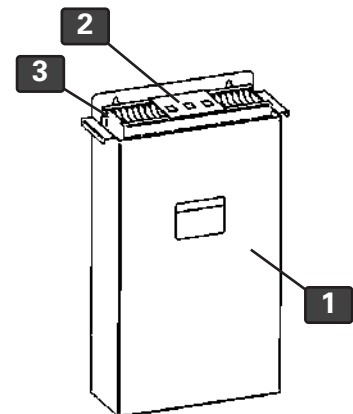

NOTE: The EAC cell is NOT designed to withstand washing in commercial dishwashers.

4-02.14. Charcoal Filter Removal



1 Place in OFF position

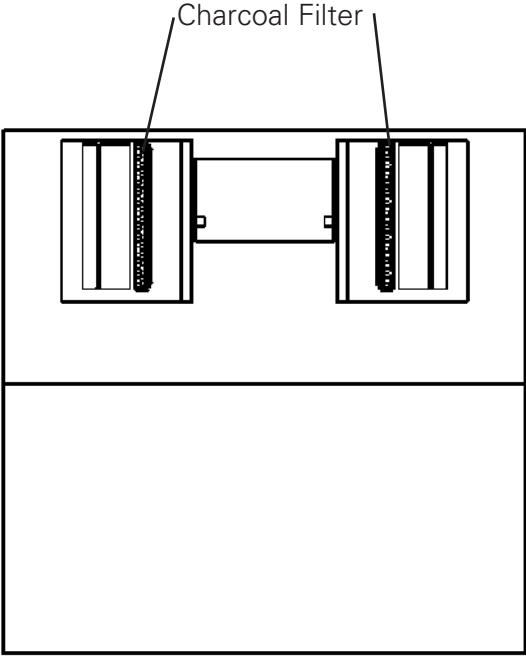

Front View

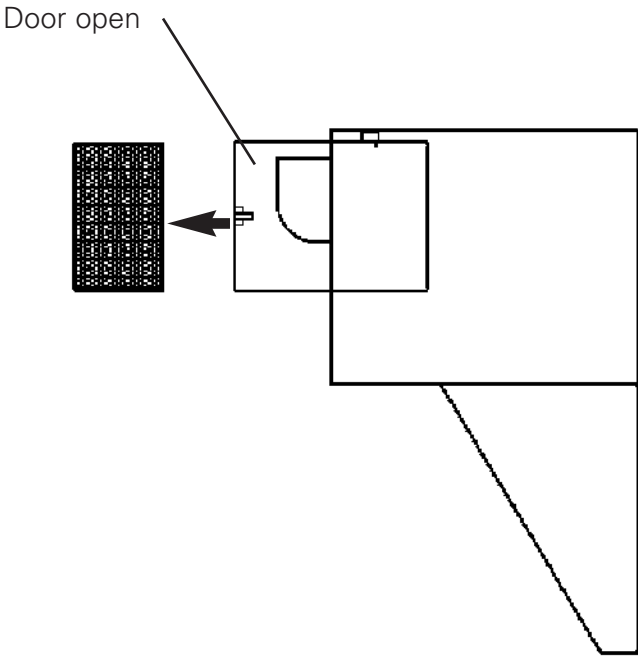

4-02.15. Charcoal Filter Installation

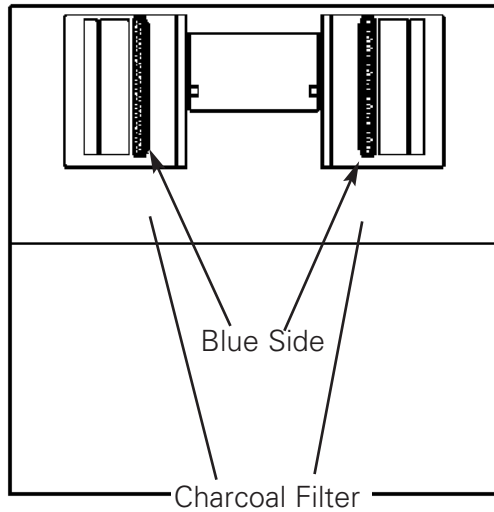

Front View

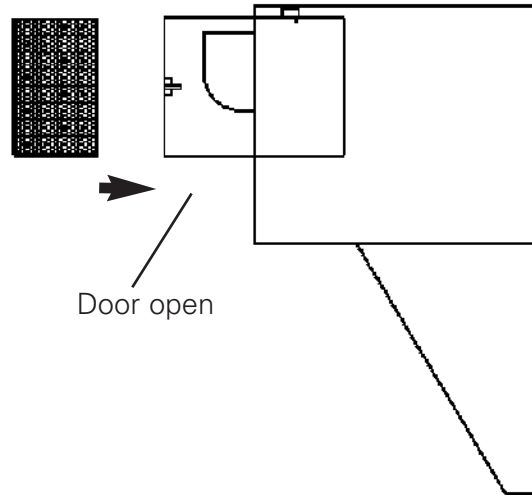

Switch Roller must be actuated by the Charcoal Filter as shown

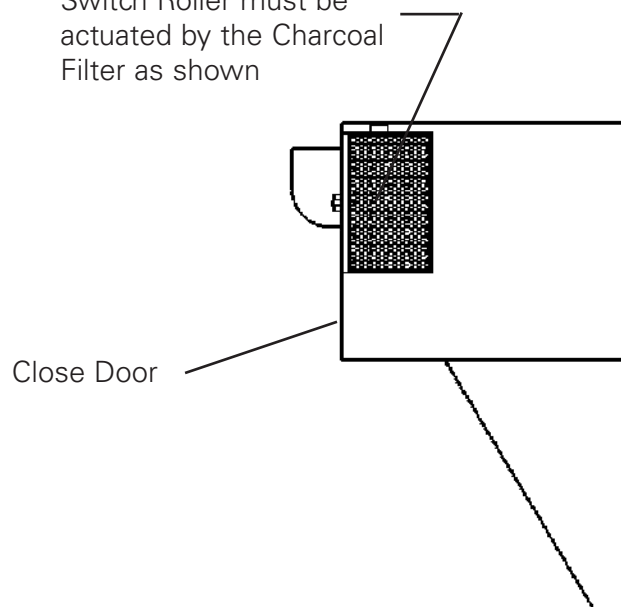

4-02.16. Charcoal Filter Missing

If either Charcoal Filter is missing or not properly positioned and the unit is on, the Filter Missing Light **1** will illuminate and power to cooking appliance is interrupted until the condition is corrected (Appliance Powered light will turn **OFF**). Section 4-2.15 Charcoal Filter Installation.



1

4-02.17. Charcoal Filter Replacement



- **NEVER attempt to clean and re-use the Charcoal Filter. This could cause damage to the unit.**

Replace the Charcoal Filter every 30 days. Use Replacement Part No. 31964.

Please take the time to record installation date in space provided on the new filter label.

4-03. Filter Alarm Chart

Alarm Sound	What will happen	Filter affected	Cause	Solution	See Section
Continuous tone	Alarm sounds, "Clogged Filter" lamp illuminates and power to the appliance is shutdown, "Appliance Powered" light is OFF . (If ILS model, the hood fan will also shutdown)	Charcoal or Pre-Filter	Filter dirty	Replace Filter	4-02.15. & 4-02.17. or 4-02.07 & 4-02.09
Continuous tone	Alarm sounds, "Clogged Filter" lamp illuminates and power to the appliance is shutdown, "Appliance Powered" light is OFF . (If ILS model, the hood fan will also shutdown)	Baffle	Filter dirty	Clean Filter	4-02.03. & 4-02.05
Intermittent tone	"Check" and/or "Wash" LED's will illuminate, alarm sounds, after approx. 2 minutes, power to the appliance is shutdown, "Appliance Powered" light is OFF . (If ILS model, the hood fan will also shutdown)	E.A.C.	Filter dirty	Clean Filter	4-02.11. and 4-02.13



Notes:

5. Hood Cleaning and Maintenance

This Section describes cleaning and maintaining the Hood System. Attention to these procedures will help ensure the hood remains efficient over time.

A **Maintenance & Service Log** is provided in this manual, see Section 5-6.

5-1. Monthly Interlock Check

The Giles Ventless Hood System is designed with various interlock devices to ensure the unit operates in a safe and effective manner. These interlocks should be tested MONTHLY as described below. Use the **Maintenance & Service Log** and place a check in the box that corresponds to each function test. If a problem is found call your service representative.

1. **Baffle Filter Check:** Place power switch in the **OFF** position, remove the left-side Baffle Filter ... turn power **ON**. "Filter Missing Light" should be illuminated and "Appliance Powered" light should be **OFF**. Turn power **OFF** and reinstall the Grease Baffle Filter. Follow the same procedure to check the right-side Filter.
2. **Pre-Filter/Door Interlock Check:** Turn power switch **ON** ... with Hood running, slightly open the Filter Access door ... confirm Hood shutdown when door is opened ... turn power switch **OFF**. Remove the left-side Pre-Filter and close door ... turn power **ON**. "Filter Missing Light" should be illuminated and "Appliance Powered" light should be **OFF**. Turn power **OFF** and reinstall Pre-Filter. Follow the same procedure to check the right-side Pre-Filter.
3. **EAC Filter Check:** Place power switch in the **OFF** position, remove the left-side EAC Filter and close door ... turn power **ON**. Wait 2 minutes ... intermittent alarm should sound and "Appliance Powered" light should be **OFF**. Turn power switch **OFF** and reinstall EAC Filter. Follow the same procedure to check right-side EAC Filter.
4. **Charcoal Filter Check:** Place power switch in the **OFF** position, remove the left-side Charcoal Filter and close door ... turn power **ON**. "Filter Missing Light" should be illuminated and "Appliance Powered" light should be **OFF**. Turn power switch **OFF** and reinstall Charcoal Filter. Follow the same procedure to check the right-side Charcoal Filter.
5. **Filter Clogged Check:** Place Hood power switch in the **ON** position. The blower will start and a continuous tone alarm should sound for 2 to 8 seconds until the blower reaches speed, then silence. Check appliance(s) power during this time; there should be no power supplied to appliance(s) until the alarm silences. If the alarm tone does not sound, fails to silence, and/or the appliance(s) fails to come on or comes on before the alarm silences, contact service agent and have the Clogged Filter interlock checked. Return Hood power switch to the **OFF** position.

5-2. Quarterly Hood Cleaning

To maintain effectiveness and performance, the hood must be cleaned, at a minimum, every 3 months. Disconnect power from the unit, preferably at a breaker. Remove all filters from the hood. Using soft cloth, sponge or towel, and a mild bio-degradable degreaser, clean the entire hood plenum and blower section. Any grease build-up on the fan blades should be removed during this cleaning.

5-3. Semi-Annual Fire Suppression System Service

(Consult the Giles Enterprises Design Installation, Recharge and Maintenance Manual for complete servicing guidelines).

Servicing and inspection of the fire suppression system must be performed by certified, qualified fire protection equipment specialists. As a minimum, field inspection of the Fire Suppression System must be conducted semi-annually. Such maintenance shall consist of the following:

Place fire extinguishing system locking bar on fire system when inspecting or servicing.

1. Inspect storage tank for chemical level and charge pressure. Inspect release mechanism.
2. Check all nozzles to insure they are free of grease buildup. See Section 2-06.4, Extinguisher Nozzle locations.
4. Test the remote manual pull station for activation and wear.
5. Install test link and cut to simulate automatic actuation.
6. Clean and inspect fusible links. See Section 2-06.2 for Fusible Link locations.
7. Inspect fusible link wire cabling for wear at pulleys and detectors ... replace if necessary.
8. Record maintenance date and service performed in a permanent file.

5-4. Annual Fire Suppression System

Same as Semi-Annual with the exception that all fusible links must be replaced with new links. See Section 2-06-2, Fire Suppression Fusible Links.

5-5. 12 Year Fire Suppression System

Same as Annual except for the following:

1. Replace R-102 fire suppressant chemical.
2. Hydrostatically test the holding tank and charging cartridge. Can be replaced with new components that have current hydrostatic certifications.
3. Flow test the regulator.

Hood Cleaning and Maintenance

Model: FSH-3.5 & FSH-4

5-6 Maintenance & Service Log

Check								Initial/Date	Check								Initial/Date					
✓	✓	✓	✓	✓				ABC 1/2/03	1	2	3	4	5									
1	2	3	4	5					1	2	3	4	5									
1	2	3	4	5	6				1	2	3	4	5	6								
1	2	3	4	5					1	2	3	4	5									
1	2	3	4	5					1	2	3	4	5									
1	2	3	4	5	6	7*	8*		1	2	3	4	5	6	7*	8*						
1	2	3	4	5					1	2	3	4	5									
1	2	3	4	5					1	2	3	4	5									
1	2	3	4	5	6				1	2	3	4	5	6								
1	2	3	4	5					1	2	3	4	5									
1	2	3	4	5					1	2	3	4	5									
1	2	3	4	5	6	7*	8*		1	2	3	4	5	6	7*	8*						
1	2	3	4	5					1	2	3	4	5									
1	2	3	4	5					1	2	3	4	5									
1	2	3	4	5	6				1	2	3	4	5	6								
1	2	3	4	5					1	2	3	4	5									
1	2	3	4	5					1	2	3	4	5									
1	2	3	4	5	6	7*	8*		1	2	3	4	5	6	7*	8*						
1	2	3	4	5					1	2	3	4	5									
1	2	3	4	5					1	2	3	4	5									
1	2	3	4	5	6				1	2	3	4	5	6								
1	2	3	4	5					1	2	3	4	5									
1	2	3	4	5					1	2	3	4	5									
1	2	3	4	5	6	7*	8*		1	2	3	4	5	6	7*	8*						
1	2	3	4	5					1	2	3	4	5									
1	2	3	4	5					1	2	3	4	5									
1	2	3	4	5	6				1	2	3	4	5	6								
1	2	3	4	5					1	2	3	4	5									
1	2	3	4	5					1	2	3	4	5									
1	2	3	4	5	6	7*	8*		1	2	3	4	5	6	7*	8*						

1	Baffle Filter Check	Section 5-1
2	Pre-Filter/Door-Interlock Check	Section 5-1
3	EAC Filter Check	Section 5-1
4	Charcoal Filter Check	Section 5-1
5	Filter Clogged Check	Section 5-1
6	Quarterly Cleaning	Section 5-2
7*	Fire Suppression System	Section 5-3
8*	Fire Suppression System replace Fusible Links	Section 5-4

*** Must be performed by a certified, qualified fire protection equipment company.**



Notes:

6. Troubleshooting

This section describes basic troubleshooting procedures for the FSH-3.5/4. The wiring diagram attached inside the back cover is provided to assist qualified technicians with more in-depth troubleshooting.

DANGER

- Electrical troubleshooting procedures should be performed **ONLY** by a qualified service technician or electrician. Death or serious injury will result from contact with energized electrical components.
- Failure to comply with these **DANGER** notices can result in death or serious injury, equipment or property damage, and possibly void the warranty.

6-1 Troubleshooting Procedures

Problem	Probable Cause	Corrective Action
Hood will not turn on	a. (ILS Only) "HOLD TO START" button not held for 5 seconds	a. Hold down "HOLD TO START"
	b. Faulty power switch	b. Replace power switch.
	c. Improper supply voltage	c. Connect to proper voltage source.
	d. Filter Access Door not closed	d. Close access door.
	e. Not properly connected to power source.	e. Connect to proper power source.
	f. Blown fuse or tripped circuit breaker.	f. Check fuse or breaker.
Filter Missing Light illuminated • Initial Start-up Only	a. Baffle filter is not installed	a. Install Baffle filter.
	b. Charcoal filter is not installed	b. Install charcoal filter.
	c. Pre-Filter is not installed	c. Install pre-filter.
Check or Wash LED illuminated • LED light cluster for each side's filter.	a. EAC shorted	a. Replace or repair EAC.
	b. EAC dirty	b. Clean EAC.
	c. High voltage power supply faulty.	c. Replace high voltage power supply
	d. High voltage wires shorted.	d. Correct shorted condition.
	e. Bad contact plate	e. Replace contact plate.

6-1 Troubleshooting Procedures (Cont'd.)

Problem	Probable Cause	Corrective Action
Appliance will not heat <ul style="list-style-type: none"> • Hood power ON • FILTER MISSING light ON • APPLIANCE POWERED light OFF 	a. Baffle Filter missing	a. Install Baffle Filter
	b. Baffle Filter not installed properly	b. Reinstall Baffle Filter
	c. Charcoal Filter missing	c. Install Charcoal Filter
Appliance will not heat <ul style="list-style-type: none"> • Hood power ON • FILTER CLOGGED light ON • APPLIANCE POWERED light OFF • Alarm emitting a continuous tone 	a. Charcoal Filter clogged	a. Replace Charcoal Filter
	b. Baffle Filter clogged	b. Clean Baffle Filter
	c. Clogged filter switch out of adjustment	c. Adjust clogged switch only. (initial start-up switch bad)
	d. Kinked vacuum line	d. Remove vacuum line kinks
	e. Fan running slow	e. Check voltage
Appliance will not heat <ul style="list-style-type: none"> • Hood power ON • CHECK and/or WASH LED's ON • APPLIANCE POWERED light OFF • Alarm emitting an intermittent tone 	a. EAC shorted	a. Repair EAC
	b. EAC dirty	b. Clean EAC
	c. EAC power supply faulty	c. Replace EAC power supply
	d. EAC wires shorted	d. Check voltage
	e. Bad contact plate	e. Replace contact plate
	f. EAC module faulty	f. Replace EAC module
	g. EAC ionizer wire broken or missing	g. Replace ionizer wire

7. Parts List

This section lists various replacement parts available for the FSH-3.5 & FSH-4.

7-1 Parts Ordering and Service Information

If you require assistance or need repairs, please contact an area Giles dealer to assist with locating a service provider in your area or for further assistance, please contact Giles Enterprises directly at the following phone numbers:

IN THE UNITED STATES, CANADA or MEXICO

Please call **800.554.4537** during normal business hours, 8:00AM to 5:00PM Central Time; other than normal business hours, call **800.554.4537** and follow recorded prompts to reach after-hours support.

IN ALL OTHER COUNTRIES

Please call **334.272.1457** during normal business hours, 8:00AM to 5:00PM Central Time; other than normal business hours, call **334.272.1457** and follow the recorded prompts.

INTERNET

Please visit our website at: www.gfsequipment.com or e-mail services@gfsequipment.com.

The goal of the Giles team is to provide you with the highest quality service and assistance. You can help us accomplish this by obtaining the following information and having it readily available when calling. The information is recorded on a Serial Plate or Label attached to the unit.

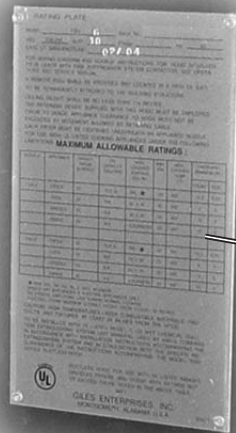

Serial Plate

Record information here for quick reference in the future.

Model Name: _____

Serial Number: _____

Phase: _____

Voltage: _____

Nature of Problem: _____

7-2 Component Drawer -FSH-3.5 & FSH-4

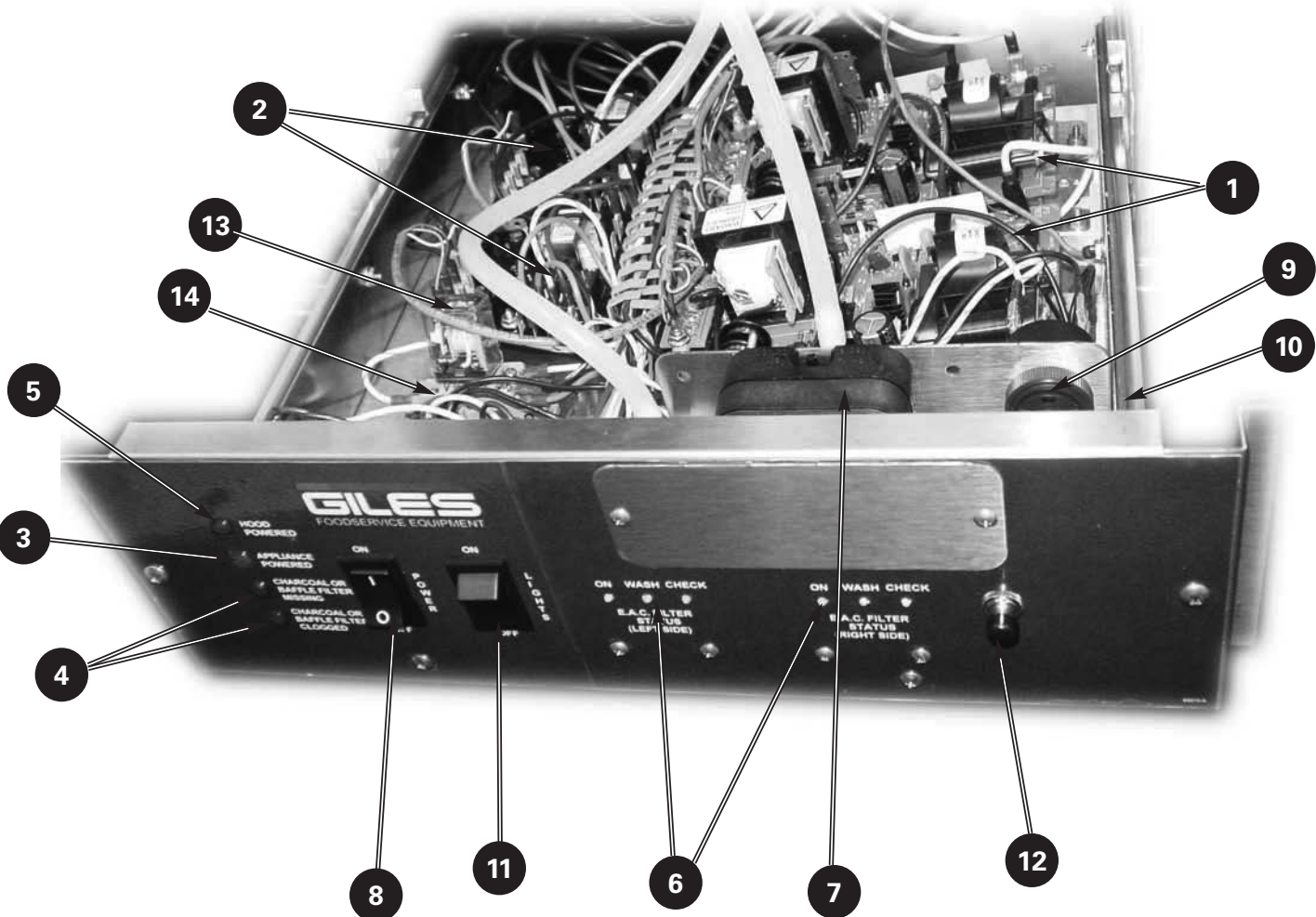

* ILS Only

7-2 Parts List for Component Drawer - FSH-3.5 & FSH-4

Item	Part No.	Qty.	Description
1	24208	2	EAC POWER SUPPLY, w/DRIVER BOARD, 208-240V
2	23776	2	ALARM & SHUTDOWN MODULE, AIR FILTER
3	20399	1	INDICATOR LIGHT, AMBER
4	20402	2	INDICATOR LIGHT, RED (250V)
5	20398	1	INDICATOR LIGHT, GREEN
6	24209	2	LED, EAC STATUS INDICATOR
7	20390	1	VACUUM SWITCH, ADJUSTABLE
8	21190	1	ROCKER SWITCH, ON-OFF, 250V, 20A, DPST
9	23782	1	SONALERT, 250V, CONTINUOUS TONE
10	22950	1	SONALERT, 250V, INTERMITTENT TONE
11	21052	1	ROCKER SWITCH, ON-OFF-ON, 250V, 20A, DPDT
12*	23173	1	SWITCH, MOMENTARY, PUSH-BUTTON (ILS PUSH TO START)
13	20318	1	RELAY, 240 VAC, 10A
14	20312	1	RELAY BASE

* ILS Only

7-3 Front View - Doors and Panel removed

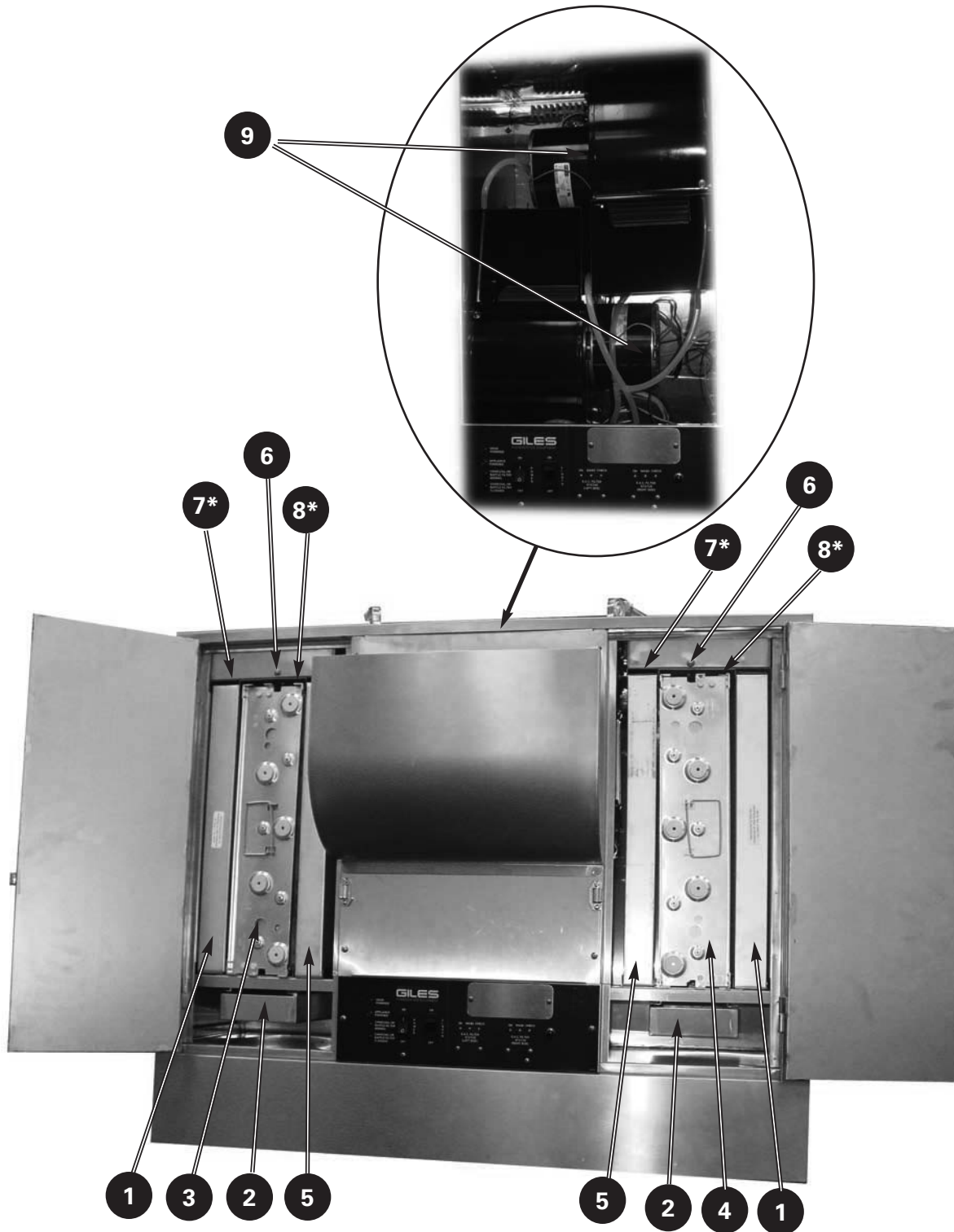

* Not shown

7-3 Parts List for Front Compartment - Doors and Panel removed

ITEM	PART NO.	QTY	DESCRIPTION
1	91707	2	PRE-FILTER, ASSY, 12 X 20 X 2
2	91545	2	DRIP CUP, EAC FILTER
3	20521	1	FILTER, EAC 12 X 20, LEFT SIDE ONLY
4	20520	1	FILTER, EAC 12 X 20, RIGHT SIDE ONLY
5	31964	2	CHARCOAL FILTER, ASSY
6	21157	2	DOOR SWITCH, FILTER ACCESS
7*	23200	4	SWITCH, SNAP ACTION, ROLLER
8*	21125	2	CONTACT BOARD, EAC FILTER
9	33589	2	BLOWER ASSEMBLY

* Not shown



7-4 Baffle Filters and Switches

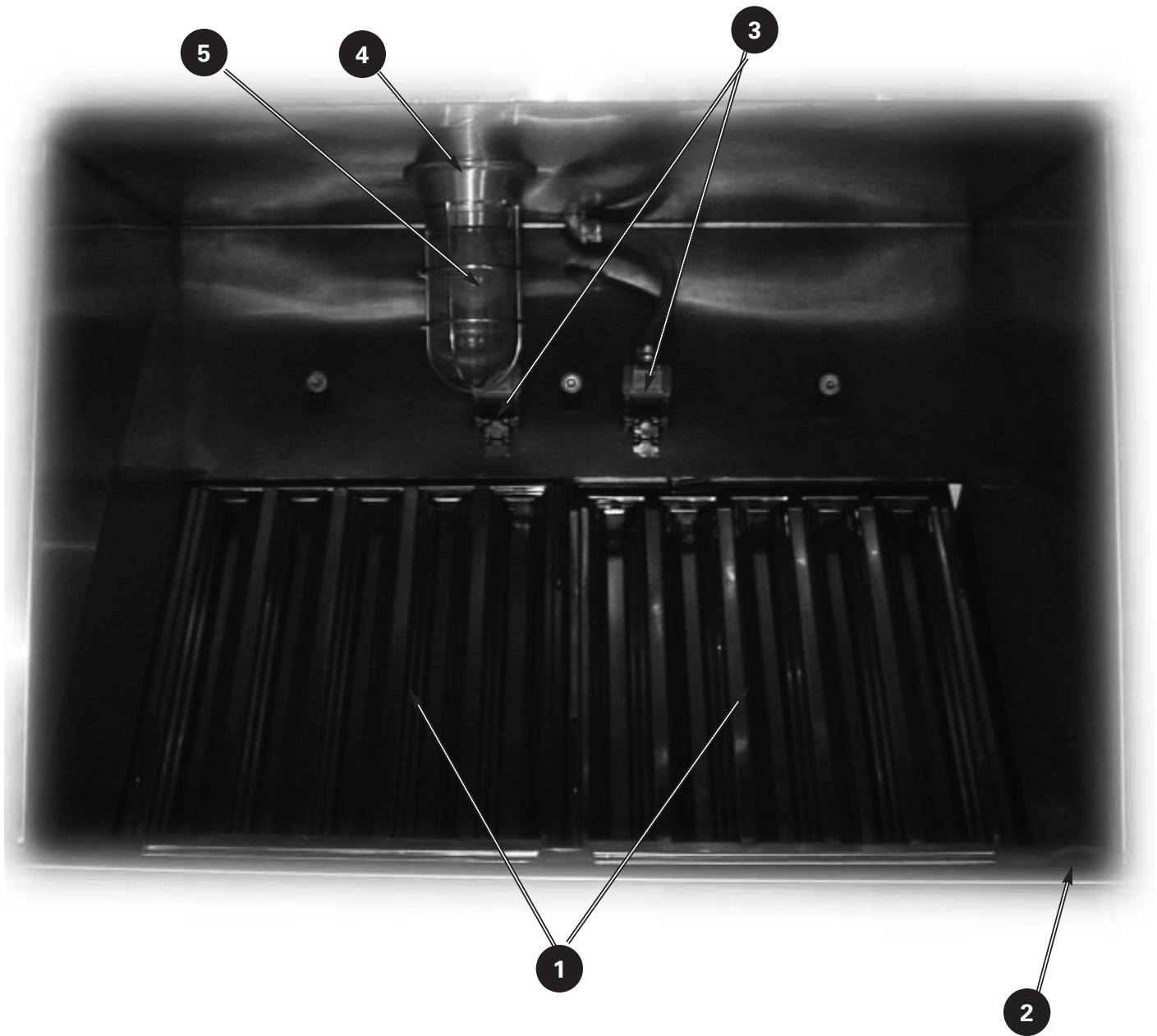

* Not shown



7-4. Parts List for Baffle Filters and Switches

ITEM	PART NO.	QTY	DESCRIPTION
1	40943	2	BAFFLE FILTER, S/S, 16 X 20
2	32776	1	DRIP CUP
3	32102	2	BAFFLE FILTER SWITCH ASSY.
4	40625	1	LIGHT FIXTURE
5	20395	1	FLUORESCENT BULB, COATED

7-5 Doors and Front Panel (Ceiling Mount)

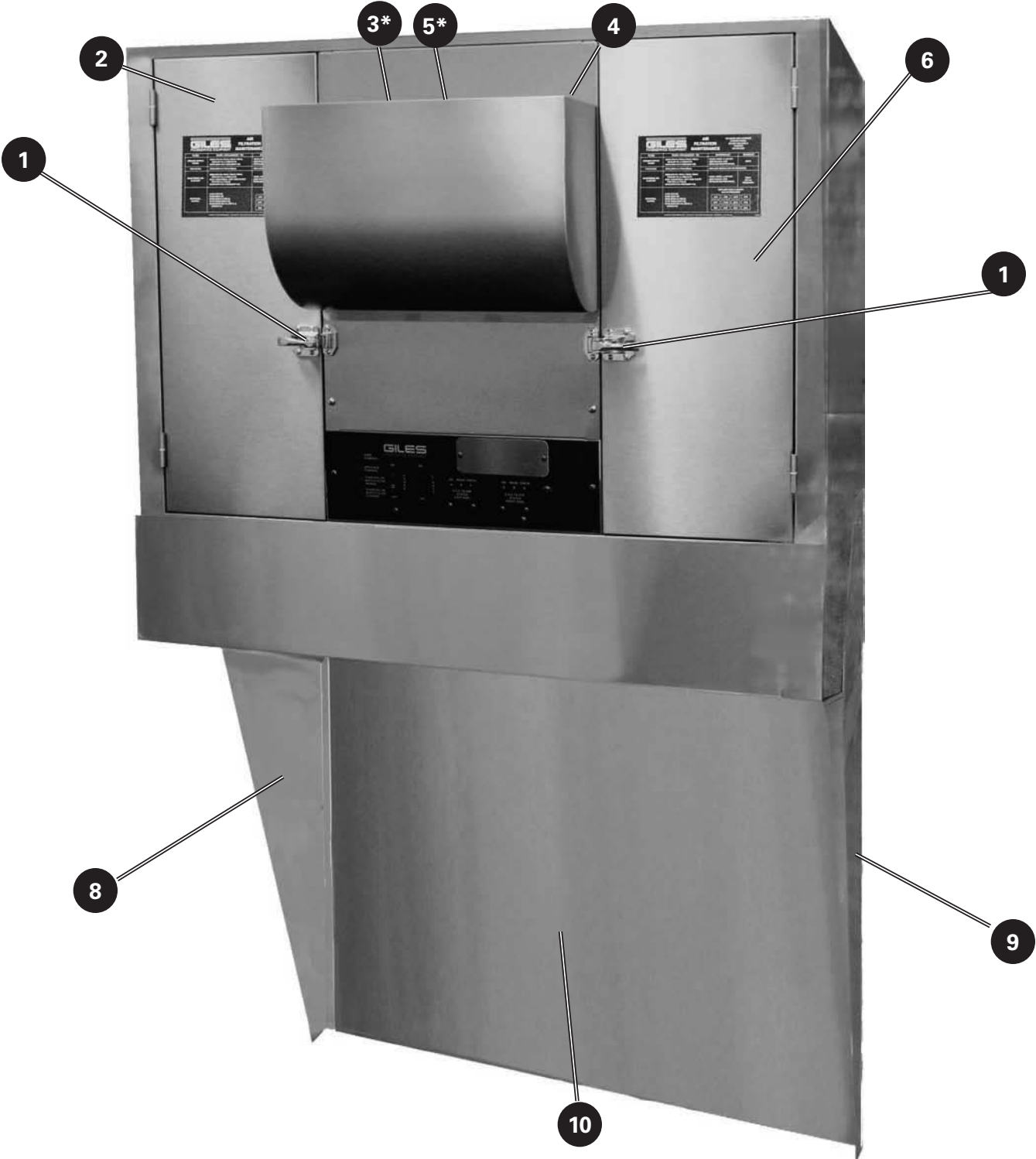

* Not shown



7-5 Parts List for Doors and Front Panel (Ceiling Mount)

ITEM	PART NO.	QTY	DESCRIPTION
1	42827	2	DOOR LATCH
2	91476	1	ACCESS DOOR ASSY, LEFT
3*	40929	1	FIRE DAMPER
4	91553	1	FAN COVER
5*	91699	1	GUARD, FIRE DAMPER
6	91475	1	ACCESS DOOR ASSY, RIGHT
8	91709	1	SIDE-SKIRT PANEL, LEFT
9	91710	1	SIDE-SKIRT PANEL, RIGHT
10	91705	1	BACK-SLASH PANEL, FSH-3.5
10	92101	1	BACK SPLASH PANEL, FSH-4

* Not shown

7-6. Doors and Front Panel (Free-Standing)

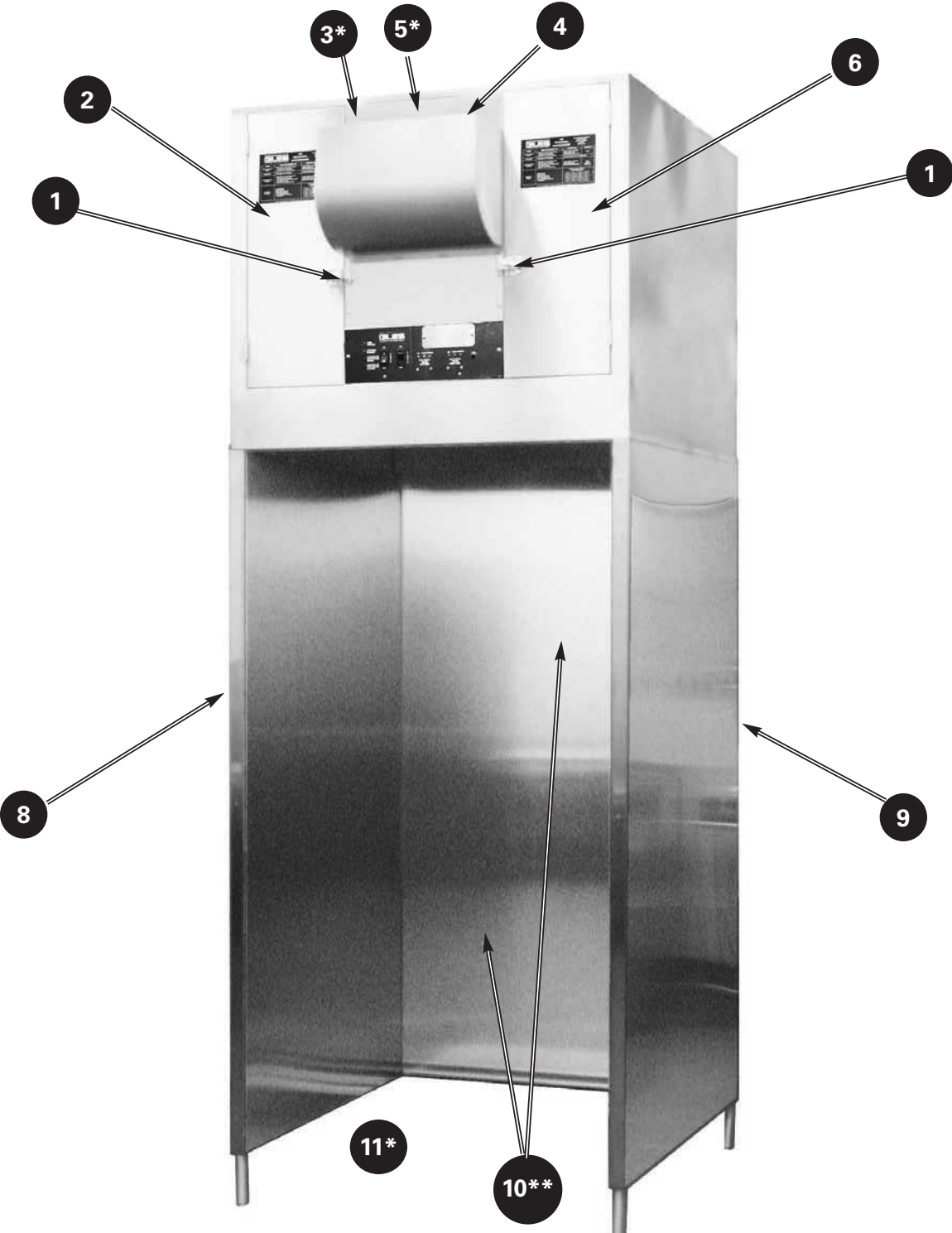

* Not shown

** Consist of (2) pieces on FSH-4



7-6. Parts List for Doors and Front Panel (Free-Standing)

ITEM	PART NO.	QTY	DESCRIPTION
1	42827	2	DOOR LATCH
2	91476	1	ACCESS DOOR ASSY, LEFT
3*	40929	1	FIRE DAMPER
4	91553	1	FAN DUCT PANEL
5*	91699	1	GUARD, FIRE DAMPER
6	91475	1	ACCESS DOOR ASSY, RIGHT
8	91574	1	78" HOOD STAND SIDE, LEFT
8	91583	1	72" HOOD STAND SIDE, LEFT
9	91577	1	78" HOOD STAND SIDE, RIGHT
9	91586	1	72" HOOD STAND SIDE, RIGHT
10	91579	1	78" HOOD STAND BACK PANEL, FSH-3.5
10	91588	1	72" HOOD STAND BACK PANEL, FSH-3.5
10 (2 pcs)	92098	1	78" HOOD STAND TOP BACK PANEL, FSH-4
	92125	1	78" HOOD STAND BOTTOM BACK PANEL, FSH-4
10 (2 pcs)	92100	1	72" HOOD STAND TOP BACK PANEL, FSH-4
	92127	1	72" HOOD STAND BOTTOM BACK PANEL, FSH-4
11*	91530	2	CHANNEL, APPLIANCE POSITION, FSH-3.5
11*	92128	2	CHANNEL, APPLIANCE POSITION, FSH-4

* Not shown



Notes:

Model: FSH-3.5 & FSH-4





Giles Enterprises, Inc.

2750 Gunter Park Drive West • Montgomery, Al 36109 USA
Phone 334.272.1457 • Service Hotline 800.554.4537 (USA & Canada Only) • FAX 334.239.4117 • www.gfsequipment.com

Form No. 65497 (Release date: 04/09) (Revision Date: 08/10 Rev. B)