

# *Operations & Service Manual*

**GVH-C &  
GVH-F HOOD**



**Giles Enterprises, Inc.**

**An ISO 9001-2008 Registered Company • Committed to Quality**

2750 Gunter Park Drive West • Montgomery, AL 36109 USA

Phone: 334.272.1457 • Fax: 334.239.4117 • Website: [www.gfse.com](http://www.gfse.com)

Toll Free: **800.554.4537** (USA & Canada Only)

Item No. 65877 (Release Date 4/2/12: Rev. A)



## LIMITED WARRANTY

- Subject to the terms and conditions of this Limited Warranty as herein stated, all Giles Enterprises, Inc., Foodservice Equipment and parts purchased new from an authorized Giles Enterprises, Inc., representative are warranted as to defects in material or workmanship for a period of 24 months from the date of installation, provided, however, that with regard to labor costs in connection with this warranty, see below. All installations must be made by a qualified installing agency in accordance with all applicable codes and/or regulations in the jurisdiction in which installed. Limited warranty coverage is extended to the original owner only and is void if the unit is resold.
- During the Limited Warranty period, Giles Enterprises, Inc. will replace or recondition, at its factory, any part or parts of this unit which Giles Enterprises, Inc. inspectors judge defective, provided the unit has been subjected to normal usage, properly installed, operated and serviced. This Limited Warranty does not cover cosmetic damage, and damage due to acts of God, accident, misuse, alteration, negligence, abuse of the Giles Foodservice Equipment or the use of unorthodox repair methods. All parts replaced under this Limited Warranty carry only the unexpired term of this Limited Warranty. Limited Warranty service may be furnished only by an authorized Giles Enterprises, Inc., representative.
- If Limited Warranty service is requested, Giles Enterprises, Inc., will send factory-authorized service representatives to repair, recondition, replace or inspect units of its manufacture with such labor being rendered without cost to owner for 24 months from the date of installation. Otherwise, service, including labor and transportation charges or other expenses, in connection with the removal or installation of any part or parts supplied under this Limited Warranty, are specified on the original sales contract between the purchaser and the authorized Giles Enterprises, Inc., representative.
- Giles Enterprises, Inc. reserves the right to change or improve its equipment and parts in any way without obligation to alter such equipment or parts previously manufactured.
- Giles Enterprises, Inc. makes no further warranties, express or implied including implied warranties of merchantability or fitness for a particular purpose, and has no other obligation or liability not specifically stated herein.
- Repair or replacement as provided under this limited warranty is the exclusive remedy. Giles Enterprises, Inc., shall not be liable for any incidental or consequential damages for breach of any express or implied warranty on this product, except to the extent prohibited by applicable law. Any implied warranty of merchantability or fitness for a particular purpose on this product is limited in duration to the duration of this limited warranty.
- Used Giles Enterprises, Inc., Foodservice Equipment or parts or Giles Enterprises, Inc., Foodservice Equipment or parts not purchased from an authorized Giles Enterprises, Inc., representative, carry no warranties, express or implied.



<b>Safety</b> .....	<b>v</b>
Safety Overview .....	v
Specific Safety Precautions .....	vi
<b>1. Introduction</b> .....	<b>1</b>
1-01. Construction .....	1
1-02. Standard Features .....	1
1-03. Optional Features .....	1
1-04. Specifications .....	2
1-04.1. Overall Dimensions .....	2
1-04.3. Regulatory Listings .....	4
1-04.4. Hood Weights .....	4
<b>2. Installation</b> .....	<b>5</b>
2-01. Unpacking .....	5
2-02. Location .....	6
2-02.1. Clearance to Combustibles, GVH-C .....	7
2-02.2. Clearance to Combustibles, GVH-F .....	8
2-03. Cooking Appliance Limitations & Clearances .....	9
2-03.1. Limitations and Clearances, GVH-C .....	9
2-03.2. Limitations and Clearances, GVH-F .....	10
2-04. Electrical Requirements .....	11
2-04.1. Electrical Connections .....	12
2-04.2. Hood & Appliance Wiring Configurations .....	13
2-04.2.1. Connection w/Interlocked Receptacle Option .....	13
2-04.2.2. Connection w/Hood & Appliance on same Circuit .....	14
2-04.2.3. Connection w/ 380-480V Appliance Power Separate from 208-240V Hood Power .....	15
2-04.2.4. Connection w/120V to 480V Appliance Power Separate from 208-240V Hood Power using Remote Shunt Trip Device .....	16
2-05. Fire Suppression System Installation .....	17
2-05.1. Fire Suppression System Routing .....	18
2-05.2. Fire Suppression Fusible Link Specification & Location .....	19
2-05.3. Fire Extinguisher Nozzle Locations .....	20
2-05.4. Fire Extinguisher Nozzle Alignment .....	21
2-05.5. Final Counter-Top Installation, GVH-C .....	22
<b>3. Overview</b> .....	<b>23</b>
3-01. Control Panel .....	24
3-02. Hood Front & Filter Chamber .....	26
3-03. Accessories (Standard) .....	28
3-04. Accessories (Optional) .....	29

---

---

---

**4. Operation & Filter Maintenance . . . . . 31**

4-01. Hood Operation . . . . . 31

4-01.1. Starting the Hood (Regular) . . . . . 31

4-01.2. Starting the Hood (ILS Model) . . . . . 31

4-02. Hood Filter System . . . . . 32

4-02.1. Ventless Hood Filter Table . . . . . 32

4-02.2. Filter Removal, Baffle, EAC, Charcoal . . . . . 33

4-02.3. Filter Installation, Baffle, EAC, Charcoal Filter Installation . . . . . 34

4-02.4. Charcoal or Baffle Filter Missing . . . . . 34

4-02.5. EAC Filter Missing . . . . . 34

4-02.6. EAC Filter Status . . . . . 35

4-03. Filter Maintenance . . . . . 35

4-03.1. Baffle Filter Cleaning . . . . . 35

4-03.2. EAC Filter Cleaning . . . . . 36

4-03.3. Charcoal Filter Maintenance . . . . . 36

4-03.4. UV Lamp Cleaning . . . . . 37

4-03.5. Replacing the UV Lamp . . . . . 38

4-04. Filter Alarm Chart . . . . . 39

4-05. Replacing Under-Hood Fluorescent Light . . . . . 40

**5. Hood Cleaning and Maintenance . . . . . 41**

5-01. Monthly Interlock Check . . . . . 41

5-02. Quarterly Hood Cleaning . . . . . 42

5-03. Fire Suppression System Maintenance . . . . . 42

5-03.1. Semi-Annual Fire Suppression Maintenance . . . . . 43

5-03.2. Annual Fire Suppression System . . . . . 43

5-03.3. 12 Year Fire Suppression System . . . . . 43

5-04. Maintenance and Service Log . . . . . 44

**6. Troubleshooting . . . . . 46**

6-01. Troubleshooting Procedures . . . . . 46

**7. Parts List . . . . . 48**

7-01. Parts Ordering and Service Information . . . . . 48

7-02. Rear Electrical Components . . . . . 50

7-03. Front View, Filter & Fan Compartment . . . . . 52

7-04. Under-Hood Components Filters and Switches . . . . . 54

## Safety

### Safety Overview

The instructions contained in this manual have been prepared to aid you in learning the proper procedures for installing and servicing the GVH-CF Hood.

Throughout this manual, safety precautions are identified through the use of safety alert symbols and three key words: **DANGER, WARNING** and **CAUTION**. All safety alert information will precede the step(s) to which it applies. Suggested, recommended, or otherwise noteworthy information is identified through the use of **NOTES**. Additionally, certain words are used to indicate a specific meaning or to add emphasis.

The following words are used as indicated throughout the manual:

**Shall:** understood to be mandatory.

**Should:** understood to be advisory.

**May:** understood to be permissive.

**Will:** indicates a future event or condition is highly likely to occur.

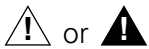

(Safety Alert Symbol)

Used in conjunction with key words **DANGER, WARNING**, or **CAUTION** to alert you of potential personal injury hazards and to highlight precautionary measures that pertain to subsequent step(s). Adhere to all safety messages following these symbols to avoid possible injury or death. Failure to comply with safety precautions identified by a safety alert symbol may also void the equipment's warranty.

#### **DANGER**

- Indicates an imminently hazardous situation which, if not avoided, will result in serious injury, or even death. Use of this is limited to the most extreme situations.

#### **WARNING**

- Indicates a potentially hazardous situation which, if not avoided, may result in serious injury, or even death.

#### **CAUTION**

- Indicates a potentially hazardous situation which, if not avoided, may result in minor to moderate injury. Also alerts against unsafe practices.

#### **CAUTION**

- When used without the safety alert symbol, **CAUTION** indicates a potentially hazardous situation which, if not avoided, may result in damage to the equipment or property, and void the warranty.

#### **NOTE:**

- Identifies suggested, recommended, or otherwise noteworthy information.

## Specific Safety Precautions

For your safety, please observe the following precautions when operating or servicing the GVH Ventless Hood. Read the following important safety information to avoid personal injury and/or damage to the equipment or property.

### **DANGER**

- Always disconnect the source of main power before removing any service panel or cover.
- Failure to ensure that the Power Switch is in the **OFF** position during servicing or when replacing filters could result in damage to the equipment, electrical shock or other serious personal injury.
- Failure to comply with these **DANGER** notices will result in serious injury or even death, equipment or property damage, and void the warranty.

### **WARNING**

- **DO NOT** use or store flammable liquids or materials that produce flammable vapors in the vicinity of this or any other appliance!
- Consult a qualified electrician to ensure that all electrical requirements are met and that the unit is properly grounded.
- Before installing or servicing this equipment, read the contents of this manual thoroughly.
- Improper installation, adjustments or alterations, or improper service/maintenance could result in serious injury or even death, damage to equipment or property, and void the warranty.
- Failure to comply with these **WARNING** notices could result in serious injury or even death, and equipment or property damage.

### **WARNING**

#### **UV MODEL ONLY**

- An internal ultraviolet radiation source is present on these models during operation.
- Keep protective covers and panels in place during normal operation. Replace any removed after servicing.
- An interlock circuit in the hood reduces potential for exposure to excessive ultraviolet radiation. **DO NOT** attempt to disconnect or bypass this interlock.
- Looking directly at a UV light source without proper eye protection can cause serious eye injury.



## CAUTION

- Maintain a minimum clearance of **18" (457.2mm)** between the hood's exhaust outlet and the ceiling, or other overhead obstruction.
- Exercise care when lifting or moving the unit. See **Section 1-4.4, Hood Weights**.
- Exercise care when removing the unit from the shipping skid.

## CAUTION

- **DO NOT** operate the unit unless you fully understand its components and their intended function.
- **DO NOT** bend the collection fins or break the ionizer wires of the Electrostatic Air Cleaner (EAC). Doing so will prevent it from working properly and cause a shutdown of power to the appliance being operated under the hood.
- Failure to comply with these **CAUTION** notices may result in minor to moderate injury, damage to equipment or property, and void the warranty.

## CAUTION

- The electronic components of the Control Panel are somewhat impact-sensitive. Exercise care when performing tasks near the unit's Control Panel to prevent possible unintentional damage.
- After cleaning the EAC, **DO NOT** attempt to dry the EAC cell by installing it in the hood and running the fan to force air dry, or by running the appliance under the hood to heat dry. This could potentially damage the EAC power system, leading to failure and voiding the warranty. The EAC filter must air dry at ambient room temperature, preferably overnight.
- When cleaning the Hood, Hood Skirt or Stand ...
  - **DO NOT** steam clean.
  - **DO NOT** spray with water from a hose.
  - **DO NOT** use products containing chlorine.
  - **DO NOT** use abrasive products, steel wool or scouring pads.
- Failure to comply with these **CAUTION** notices may result in damage to equipment or property, and void the warranty.

## NOTE:

- Giles' responsibility for the damage to the unit ends once the freight shipment is loaded onto the carrier's truck. Upon delivery, if the palletized unit showed any signs of damage, the entire load, including the supplied accessories, should have been inspected immediately and any damage to the equipment should have been promptly reported to the freight company.
- As an aid for electricians and installers, an electrical wiring diagram is provided with the unit. Refer to the wiring diagram during installation or while servicing.
- Comply with all appropriate state and/or local health regulations regarding cleaning and sanitation of foodservice equipment.
- Giles recommends the use of mild, bio-degradable, non-toxic degreasers, such as **Clear Magic** or **Simple Green**, for cleaning parts of the hood where excessive grease film accumulation is present.
- Always ensure the unit is installed and electrically grounded in accordance with local codes, or in the absence of local codes, in accordance with the **National Electrical Code ANSI/NFPA No. 70-1984**.

## NOTE:

- The approximate sound level of the hood while operating is 65 dB.

## NOTE:

- **For some installations, it may be necessary to consult a HVAC specialist to confirm that proper room air exchange is occurring and that the on-site A/C system is capable of handling the anticipated heat load.**
- Exhaust ventilation is recommended for areas in which recirculating hoods are operated. Giles recommends **50 CFM** per linear foot of hood space. **This amount could vary based on local codes and site-specific situations.**

## 1. Introduction

Thank You! for purchasing a GVH Series Ventless Hood System manufactured by Giles Enterprises, Inc., Montgomery, Alabama, USA. The GVH-C model is designed specifically for use as a counter-top hood and is listed for the removal of grease-laden cooking vapors produced by a variety of small commercial appliances. The GVH-F model is the Floor Stand version.

With proper care and maintenance, this unit will provide years of trouble-free service. To help protect your investment in this equipment, we recommend taking a few moments to familiarize yourself with the installation, operation, cleaning, and maintenance procedures described in this manual. We urge you to read this manual before installing or operating the hood. Adherence to these recommended procedures will minimize future potential for costly downtime and equipment repairs. Please retain this manual for later reference.

### 1-1. Construction

The GVH Hood is constructed of 20-Ga & 18-Ga Stainless Steel.

### 1-2. Standard Features

#### Control Panel

- **LED** light cluster indicates the status and condition of the Electronic Air Cleaner (EAC) cell.
- **Appliance Powered** light indicates that power is being supplied to the interlocked appliance(s) operating under the hood.
- **Filter Missing** light indicates that the Baffle Filter and/or the Charcoal Filter is missing or not properly installed.
- **Filter Clogged** light indicates that the Baffle Filter and/or the Charcoal Filter is possibly clogged and requires attention.

#### Filters

- Double Baffle Filter - captures and collects large grease particles entrained in the air stream.
- Electronic Air Cleaner (EAC) - captures and collects fine particulate air contaminants.
- Charcoal Filter - activated carbon filter helps to eliminate cooking odors.

#### Floor Stand Model

- Features a 61-1/2" tall Floor Stand alternative to the standard Counter-top model. Total height of Hood and Stand is 82"

### 1-3. Optional Features

#### Inter-Locked Start (ILS)

- Should there be a power interruption to the the hood, this system prevents the hood and the served appliance(s) from restarting until attended by an operator. This optional provision is required by code in certain cities and/or states.

#### Ultimate Ventless

- Ultra-violet Lamp Package, working in conjunction with Giles' proven air filtration system, sanitizes the plenum area and the exhaust air, helping to improve odor control.

## 1-3. Optional Features - Continued

### Interlocked Appliance Receptacle

- Factory-installed, 50A, NEMA receptacle ready to accept the appliance power cord. This appliance "plug-in" feature provides added convenience.

## 1-4. Specifications

### 1-4.1. Overall Dimensions - GVH-C Countertop Model

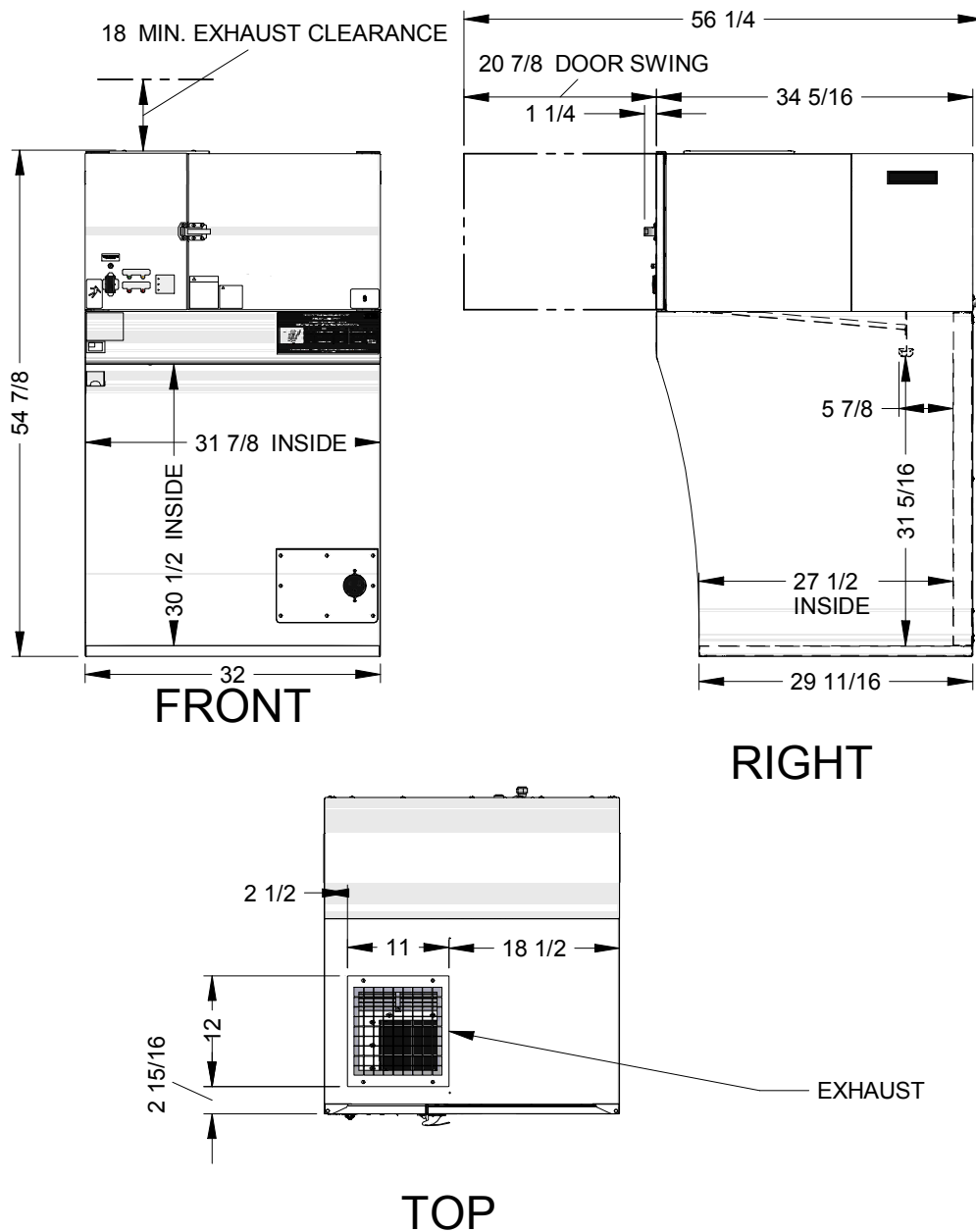

## 1-4.2. Overall Dimensions - GVH-F Floor Stand Model

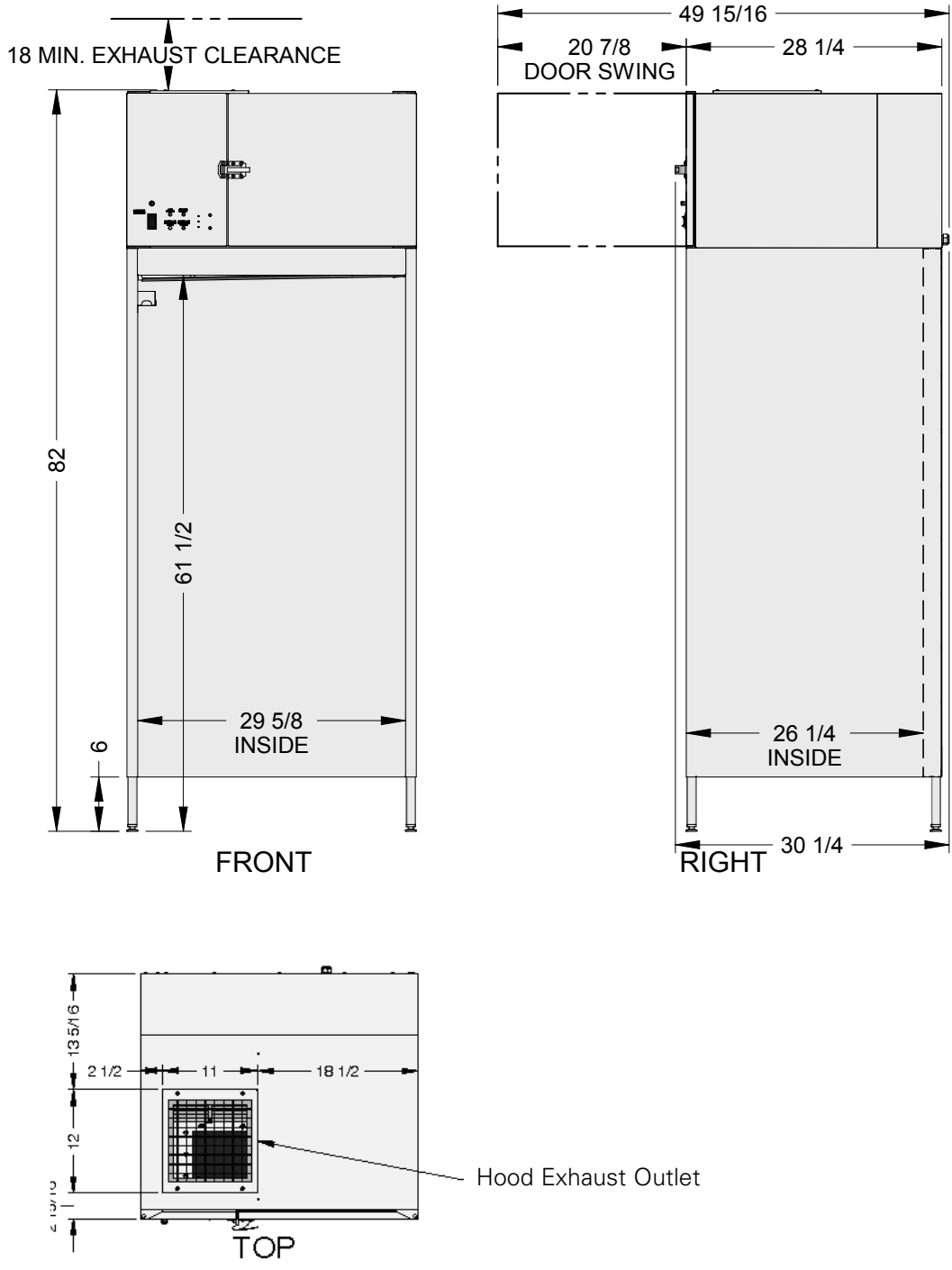

## 1-4.3. Regulatory Listings



## 1-4.4. Hood Weight

Hood	Crated Weight	Uncrated Weight
GVH-C (Counter-Top)	290 lbs [131.5 kg]	345 lbs [156.5 kg]

## 2. Installation

This section summarizes the procedures necessary to install your new GVH-C or GVH-F Hood. Before installing and attempting to operate, please read the contents of this manual thoroughly. Following these procedures will help ensure safe and proper installation.

### 2-01. Unpacking

#### !! IMPORTANT NOTE:

- If the palletized unit showed any signs of damage, you should have immediately inspected the equipment and any other packed accessories, and promptly notified the freight company of any and all damages. **Typically, it is the customer's responsibility to claim freight damage.**

The unit is shipped on a wooden skid with protective framing, secured to the skid by high-tensile plastic strapping and wrapped with machine applied stretch-wrap. Perform the following steps to unpack the unit:

1. Position the palletized unit in an area with sufficient space for unpacking.
2. Cut and remove stretch-wrap and all strapping.
3. Use appropriate tools to remove the wooden crate from around the unit.
3. Remove any packed accessories from the skid and set aside. If a Floor Stand model, carefully uncrate the Hood Stand pieces and set aside for later assembly.
4. The unit is extremely heavy. Using suitable lifting equipment or adequate manpower, lift the unit and remove it from the shipping skid. See **Section 1-4.4, Hood Weights**.
5. Properly dispose of all shipping materials.

#### CAUTION

- The unit is extremely heavy and somewhat top-heavy! Exercise due caution when handling to avoid personal injury or damage to the equipment. Take precautions not to damage the hood's Base or Skirting.
- Exercise care when removing the wooden framing from around the unit to avoid any exposed nails or staples.
- Failure to comply with these **CAUTION** notices may result in minor to moderate injury, damage to equipment or property, and void the warranty.

## 2-02. Location

### CAUTION

- DO NOT MODIFY OR ALTER THIS EQUIPMENT, OR ADD ATTACHMENTS OF ANY KIND.

### NOTE:

- For some installations, it may be necessary to consult a HVAC specialist to confirm that proper room air exchange is occurring and that the on-site A/C system is capable of handling the anticipated heat load.
- Exhaust ventilation is recommended for areas in which recirculating hoods are operated. Giles recommends **50 CFM** per linear foot of hood space. **This amount could vary based on local codes and site-specific situations.**

### NOTE:

- The sound level of the hood while operating will be approximately 65 dB.

1. Do not obstruct the exhaust air outlet. Maintain a minimum clearance of **18 inches (457.2 mm)** between the air outlet and the ceiling, or any other overhead obstruction.
2. The GVH-C Hood model is designed to sit atop a counter space. Ensure that the intended site is structurally sound and capable of supporting the hood's weight plus that of the appliance(s) to be placed under it. See **Section 1-4.4, Hood Weight.**
3. If installing a GVH-F Floor Stand model, ensure that the floor space is fairly level. The hood stand features adjustable legs to accomplish final leveling of the unit.



## 2-02.1 Clearance to Combustibles, GVH-C Model

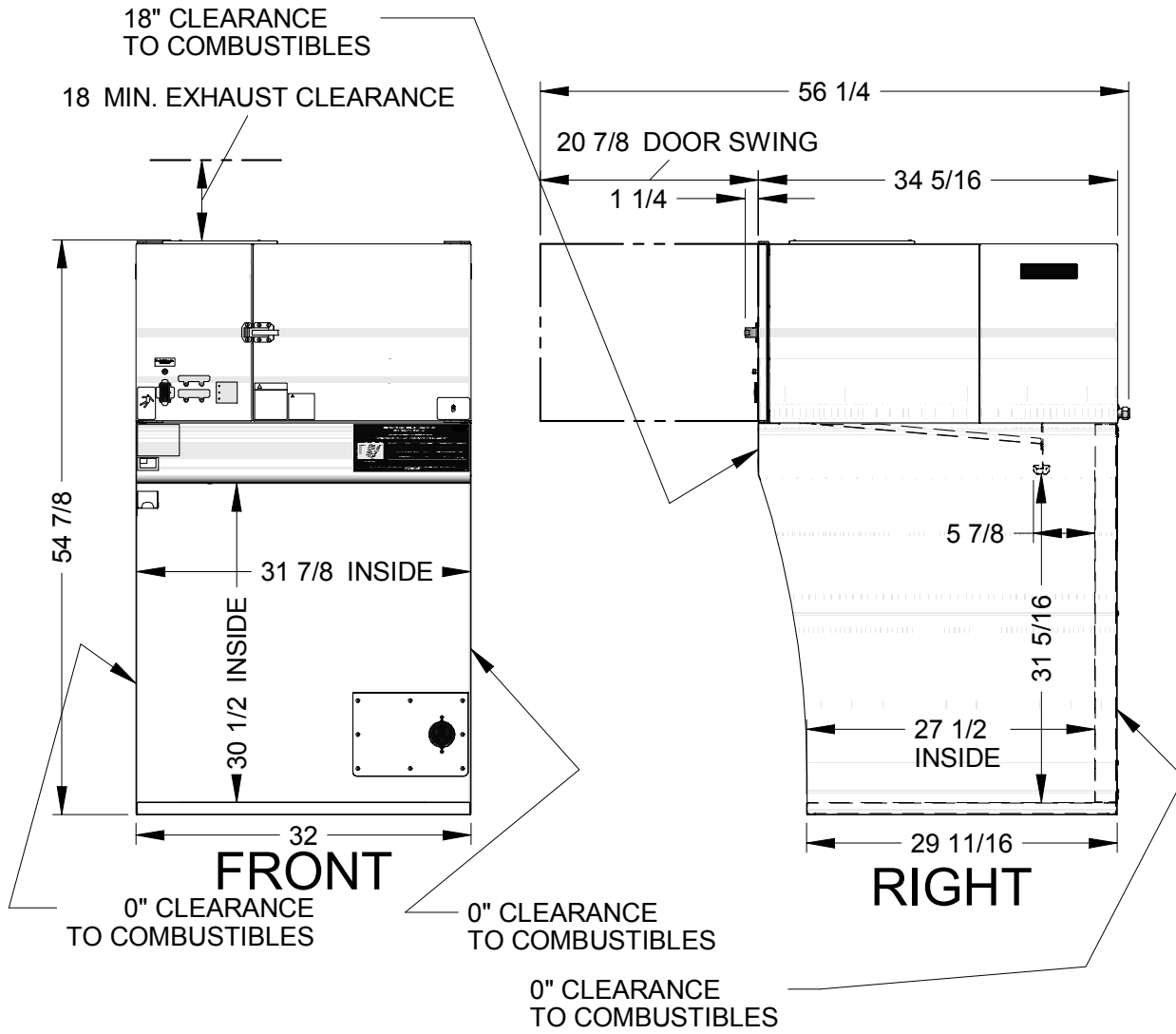

2-02.2 Clearance to Combustibles, GVH-F Model

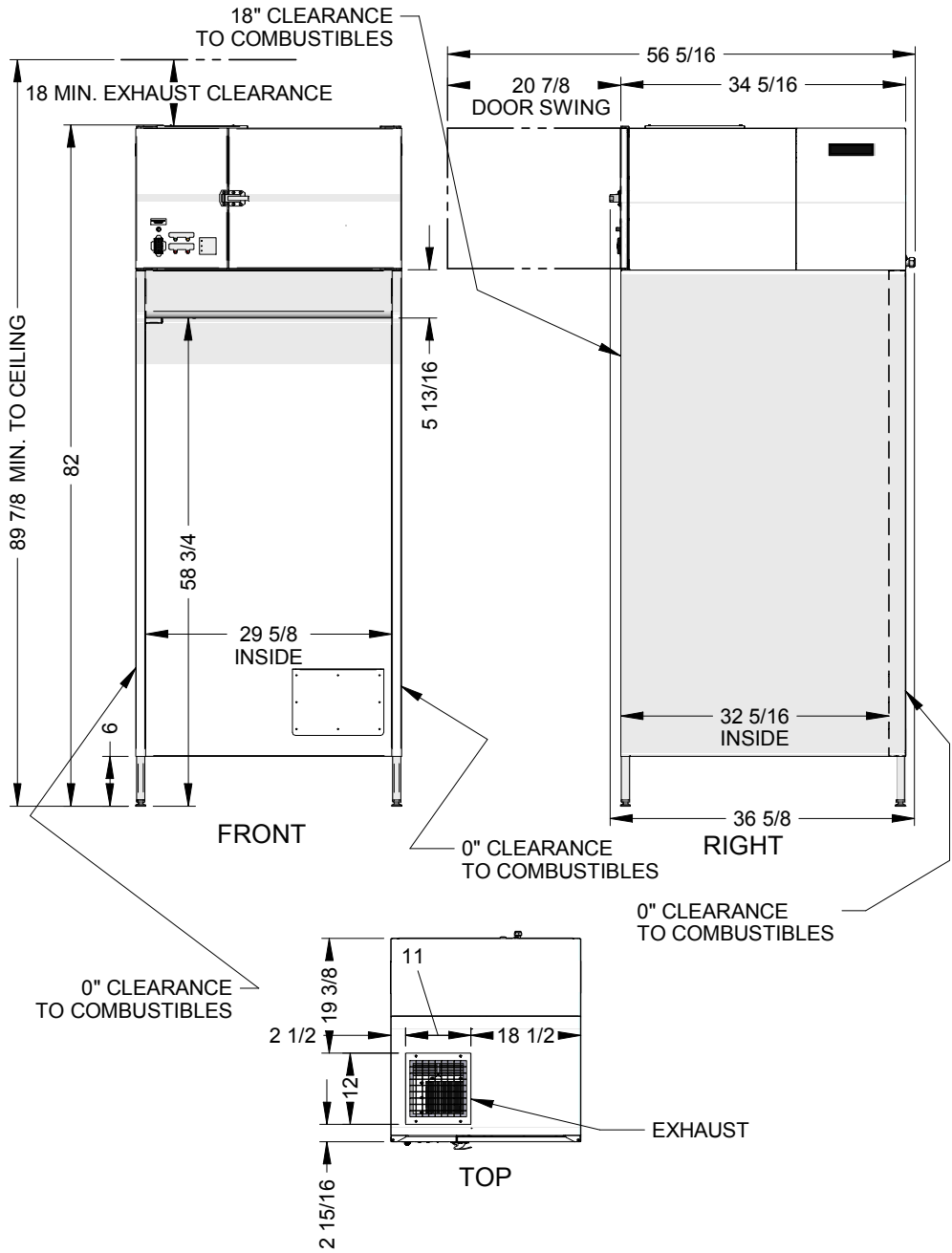

## 2-03. Cooking Appliance Limitations & Clearances

### 2-03-1. Limitations & Clearances, Model GVH-C

**Hood is listed for Electric Appliances ONLY.**

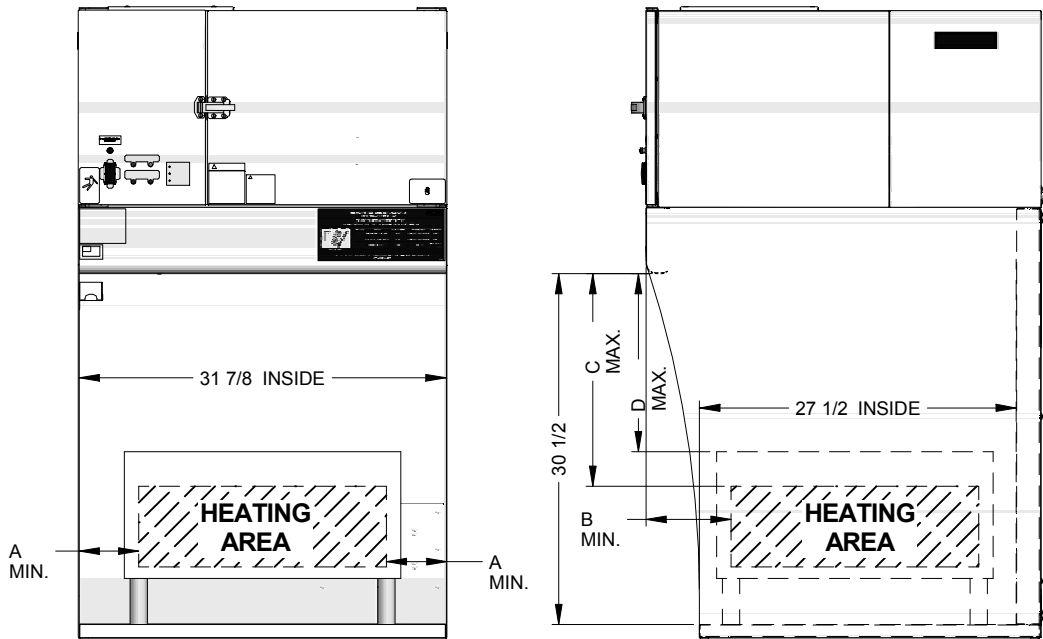

APPLIANCE RESTRICTIONS									
APPLIANCE	A	B	C	D	MAX. AMP.	MAX. SURFACE AREA	MAX. SHORTENING CAPACITY	MAX. TEMP	MAX ELEMENTS
FRYER(S)	1-1/2	8	N/A	19	100 TOTAL* (MAX 50AMP THROUGH HOOD INTERLOCK CONTACTOR)	576 SQ. IN.	140LBS/9.1 GAL	N/A	N/A
GRIDDLE	3-7/8	8-3/4	19	N/A	35	480 SQ. IN.	N/A	450F	N/A
RANGE	4	8-3/4	19	N/A	44 TOTAL ALL BURNERS	N/A	N/A	N/A	4
OVEN	1	8-3/4	19	N/A	55 TOTAL* (MAX 50AMP THROUGH HOOD INTERLOCK CONTACTOR)	N/A	N/A	500F	N/A
CONVEYOR OVEN	5-1/2	8	19	N/A	55 TOTAL* (MAX 50AMP THROUGH HOOD INTERLOCK CONTACTOR)	N/A	N/A	500F	N/A
TOASTER	1	8-3/4	19	N/A	55 TOTAL* (MAX 50AMP THROUGH HOOD INTERLOCK CONTACTOR)	N/A	N/A	500F	N/A

\* Appliance(s) exceeding 50 Amps must have a separate circuit from the Hood, but interlocked through the Hood contactor coil.

## 2-03-2. Limitations & Clearances, Model GVH-F

**Hood is listed for Electric Appliances ONLY.**

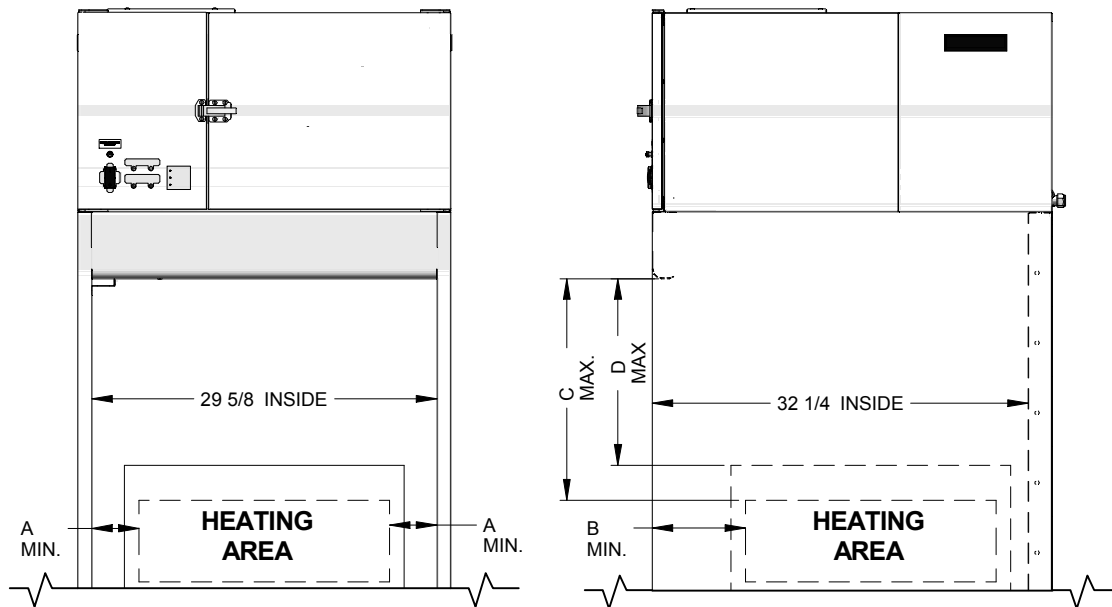

APPLIANCE RESTRICTIONS									
APPLIANCE	A	B	C	D	MAX. AMP.	MAX. SURFACE AREA	MAX. SHORTENING CAPACITY	MAX. TEMP.	MAX ELEMENTS
FRYER(S)	5/16	8	N/A	19	100 TOTAL* (MAX 50AMP THROUGH HOOD INTERLOCK CONTACTOR)	576 SQ. IN.	140LBS/9.1 GAL	N/A	N/A
GRIDDLE	2-11/16	8-3/4	19	N/A	35	480 SQ. IN.	N/A	450F	N/A
RANGE	2-7/8	8-3/4	19	N/A	44 TOTAL ALL BURNERS	N/A	N/A	N/A	4
OVEN	1	8-3/4	19	N/A	55 TOTAL* (MAX 50AMP THROUGH HOOD INTERLOCK CONTACTOR)	N/A	N/A	500F	N/A
CONVEYOR OVEN	5-1/2	8	19	N/A	55 TOTAL* (MAX 50AMP THROUGH HOOD INTERLOCK CONTACTOR)	N/A	N/A	500F	N/A
TOASTER	1	8-3/4	19	N/A	55 TOTAL* (MAX 50AMP THROUGH HOOD INTERLOCK CONTACTOR)	N/A	N/A	500F	N/A

\* Appliance(s) exceeding 50 Amps must have a separate circuit from the Hood, but interlocked through the Hood contactor coil.

## 2-04. Electrical Requirements

**⚠ WARNING**

- Consult a qualified electrician to ensure that all electrical specifications have been met and that the unit is properly grounded.
- Improper installation, adjustment, alteration, service or maintenance could result in serious injury or even death, damage to equipment or property, and void the warranty.

### Power Rating for Hood & Appliance\*\* on Same 208-240V Circuit

Voltage	Hz	Phase	Field Provided Appliance Power (Amps)	Hood Power (Amps)	Branch Circuit Protector (Amps) if Connecting Hood & Appliance on Same Circuit
208-240	60	1 or 3	0 - 10.5	1.5	15
			10.6 - 14.5	1.5	20
			14.6 - 22.5	1.5	30
			22.6 - 38.5	1.5	50
			38.6 - 46.5	1.5	60
			46.7 - 50*	1.5	70

\* Appliance(s) exceeding 50 Amps must have a separate circuit from the Hood, but intelocked through the Hood contactor coil.

\*\* Appliance provided and rated separately from Hood.

### Power Rating for Hood Only, if Appliance is on Separate Circuit & Interlocked Through Separate Contactor

Voltage	Hz	Phase	Hood Power (Amps)	Breaker
208-240	60	1	1.5	15

## 2-04.1. Electrical Connections

### **WARNING**

- All electrical installation should be performed by a qualified electrician or technician.
  - Improper installation or poor work practices could result in serious injury or even death, damage to equipment or property, and void the warranty.
1. Install appropriate circuit breaker in Main breaker box.
  2. Remove rear Hood Cover and Back Skirt Panel.
  3. Connect appropriately sized wire (**supplied by customer**) from breaker box to Hood. Allow sufficient cord length to allow moving hood, if necessary for future service or maintenance.
  4. Connect Hood and Appliance wiring to Hood terminal blocks. Several different wiring configuration options are possible depending on specific installation situations and appliance choices. See **Section 2-04.2** for specific details of these options.
  5. Replace all panels and covers.
  6. Turn on Main Breaker.
  7. Place the Hood Power Switch in the **ON** position; Hood fan will start. For **ILS** model hood, press and hold the "Push to Start" button on the Control Panel for approximately 5 seconds to start fan.
- If using a remote contactor (**Section 2-04.2.4**), the contactor must be a UL Listed, definite purpose AC resistive air heating type, suitable for the appliance load. Installation and connections shall be in accordance with the National Electric Code NFPA 70.

## 2-04.2. Hood & Appliance Wiring Configurations

### 2-04.2.1 Electrical Connection w/Interlocked Receptacle Option

APPLIANCE POWER FROM RECEPTACLE LOCATED IN HOOD. APPLIANCE AND HOOD POWER ON SAME CIRCUIT BREAKER (USING HOOD SHUNT TRIP CONTACTOR INCLUDED IN HOOD)

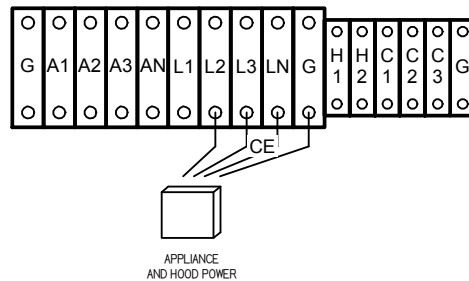
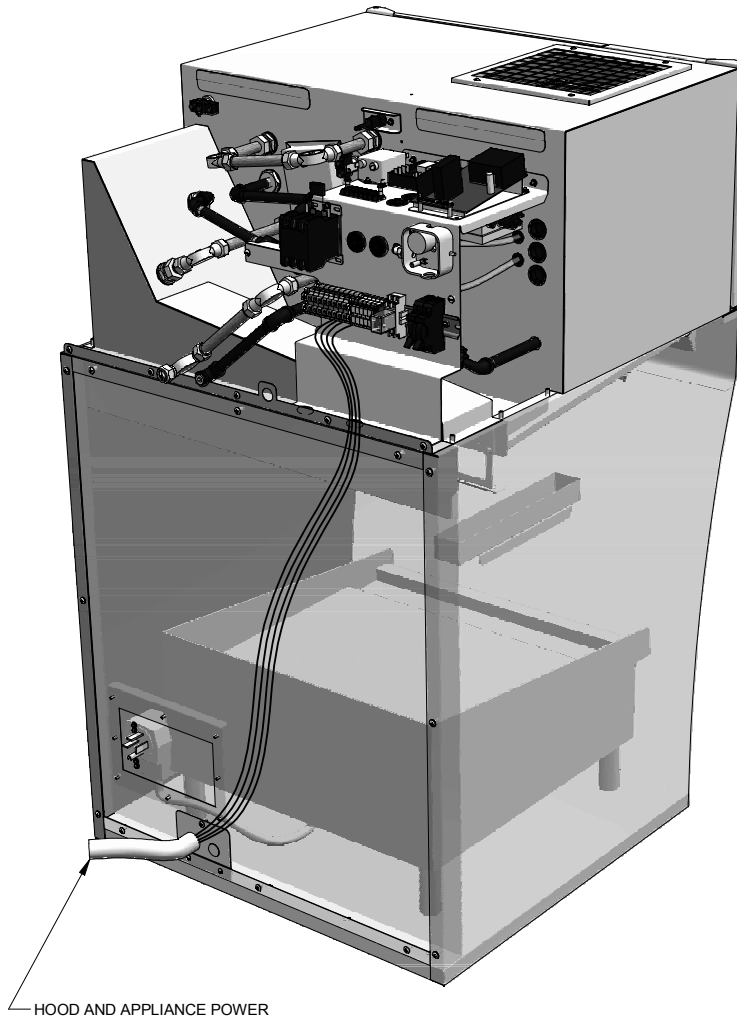

## 2-04.2.2 Electrical Connection, Hood & Appliance on same Circuit

208-240V APPLIANCE AND 208-240V HOOD POWER ON SAME CIRCUIT BREAKER

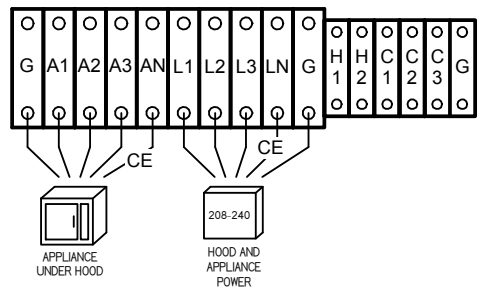
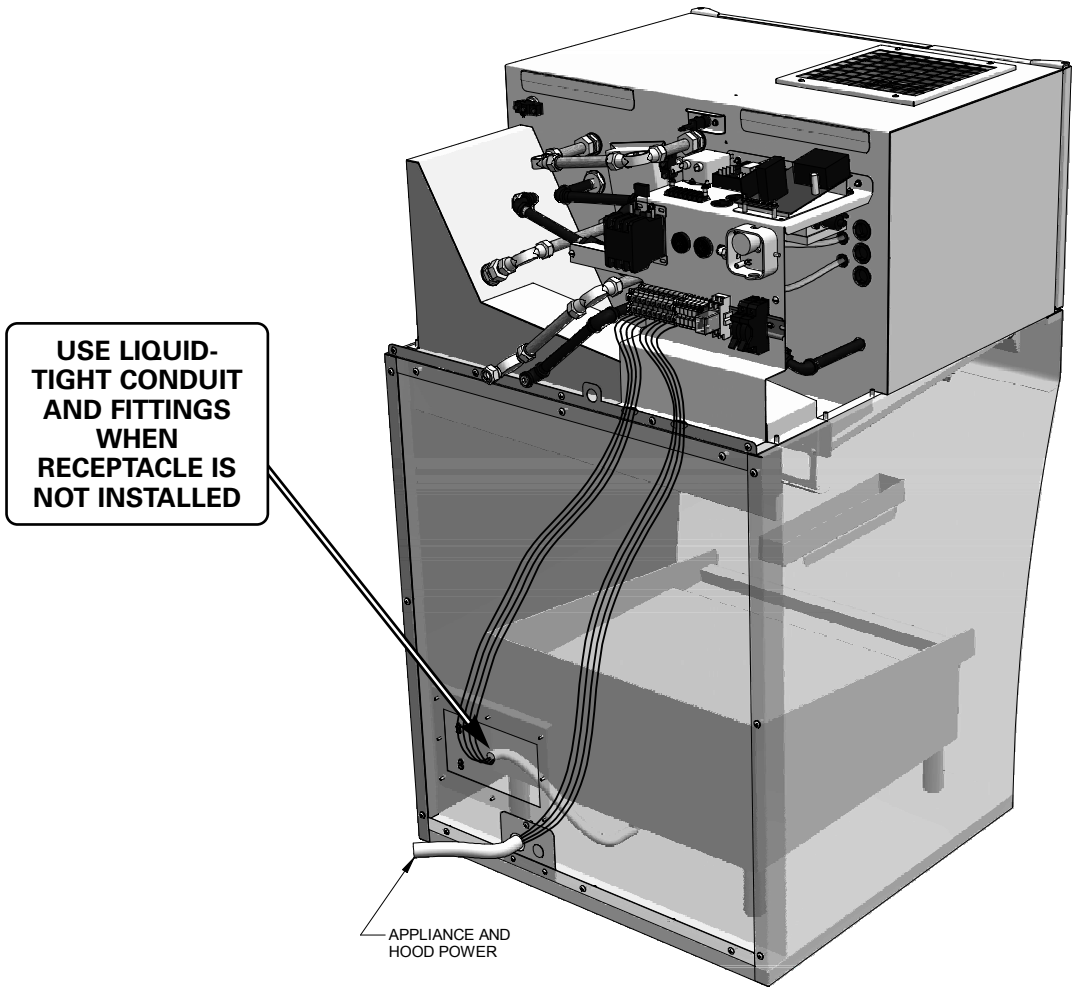



## 2-04.2.3 Electrical Connection, 380-480V Appliance Power Separate from 208-240V Hood Power

380-480V APPLIANCE POWER SEPERATE FROM 208-240V HOOD POWER (USING HOOD SHUNT TRIP CONTACTOR INCLUDED IN HOOD)

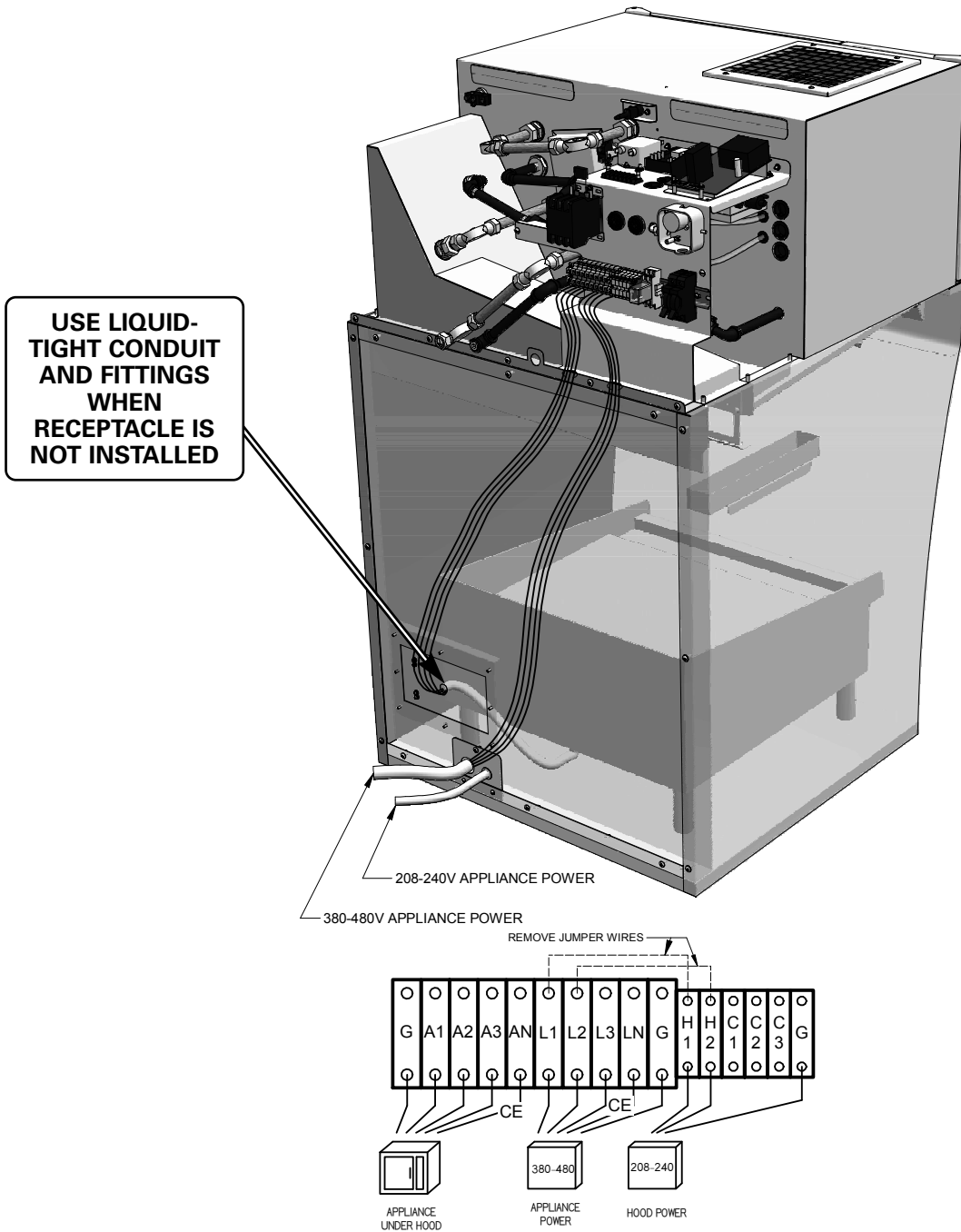

**2-04.2.4 Electrical Connection, 120V to 480V Appliance Power Separate from 208-240V Hood Power w/Remote Shunt Trip Device**

120V to 480V APPLIANCE POWER SEPARATE FROM 208-240 V HOOD POWER (USING REMOTE SHUNT TRIP CONTACTOR SUPPLIED BY LICENSED ELECTRICIAN). Contactor must be a UL Listed, definite purpose, AC resistive, air heating type, suitable for the appliance load. The Installation and connections shall be in accordance with the National Electric Code NFPA 70.

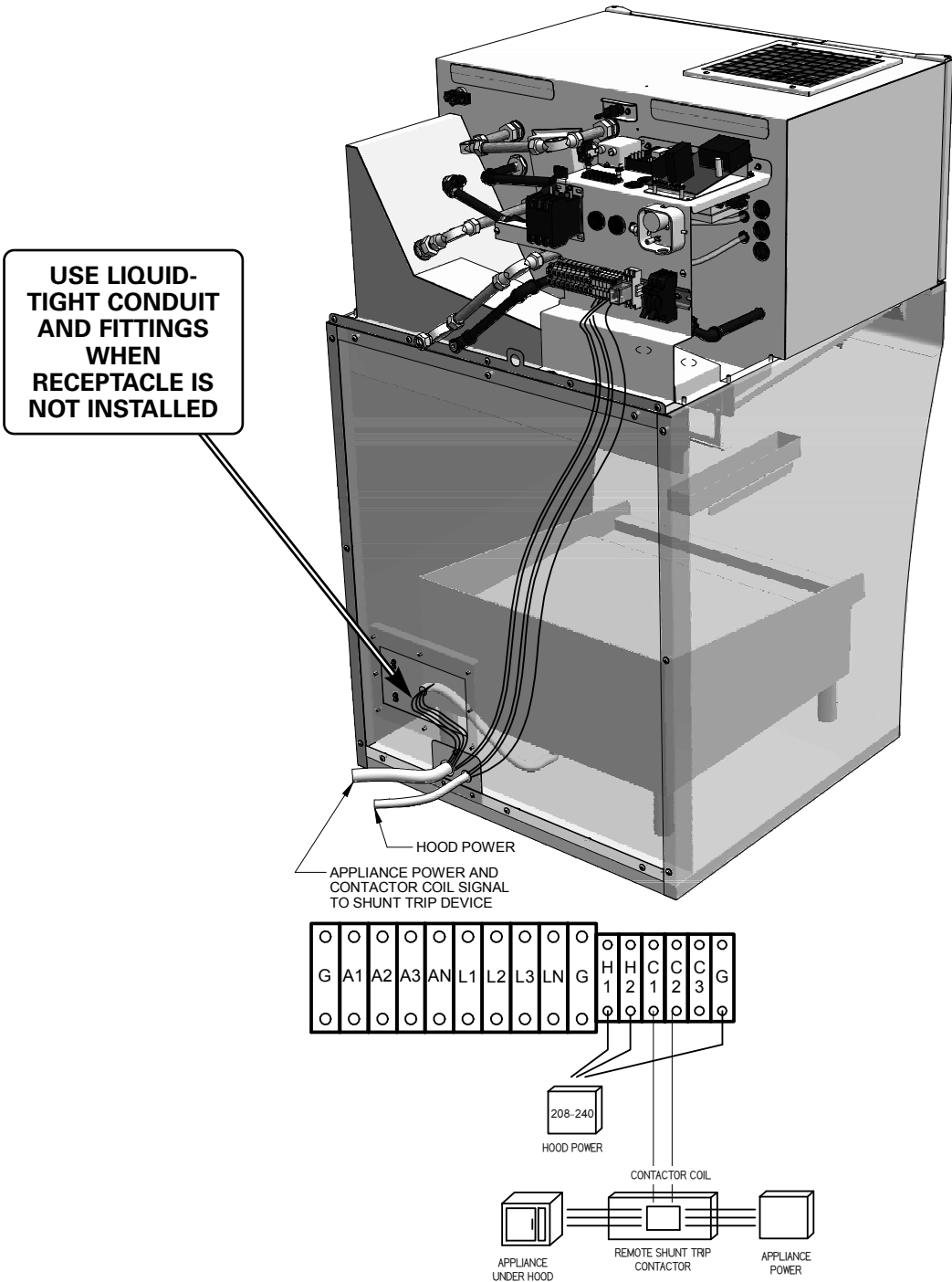

## 2-05. Fire Suppression System Installation

It is required that the Giles GVH Ventless Hood System be protected by a UL listed fire suppression system. **Procurement, final installation, testing and certification of this system is the responsibility of the customer and must be performed by a qualified Fire Protection Agent in accordance with the hood system listing.**

The GVH hood includes factory-installed suppressant piping, plenum and appliance discharge nozzles, fusible link brackets, cable conduit and wire cable. Piping and conduit are stubbed on the hood back, ready for hook-up.

1. Discharge Nozzles: Appliance, 56930-1W ... Plenum, 56929-1/2N; see **Section 2-05.3, Fire Extinguisher Nozzle Locations.**
2. Fusible Links specifications are appliance-specific. See **Section 2-05.2, Fusible Link Specification & Location.**
3. The remote Manual Actuation Device of the fire extinguishing system shall be readily accessible, in a path of exit or egress and shall be clearly identified. The installation of the Manual Actuation Device shall comply with applicable installation standards and codes. The remote Manual Actuation Device shall be installed by qualified personnel.
4. The Regulated Release Assembly with a 3-Gal suppressant tank shall be a mechanical type; typical Ansul Automan #79290.
5. See **Section 2-05.1** for the specific requirements for Fire Suppression System installation.
6. The installation, use, and maintenance of this product are to be in accordance with the **Standard for Ventilation Control and Fire Protection of Commercial Cooking Operations, NFPA 96.**



## 2-05.2. Fire Suppression Fusible Link Specification & Location

**NOTE:**

Some of the Fusible Links used in the GVH Fire Suppression System firing circuit are specific to the type of appliance(s) to be served by the hood. See the diagram below for specific manufacturer, temperature rating and part number.

**Fusible links are to be installed by an authorized fire protection agent.**

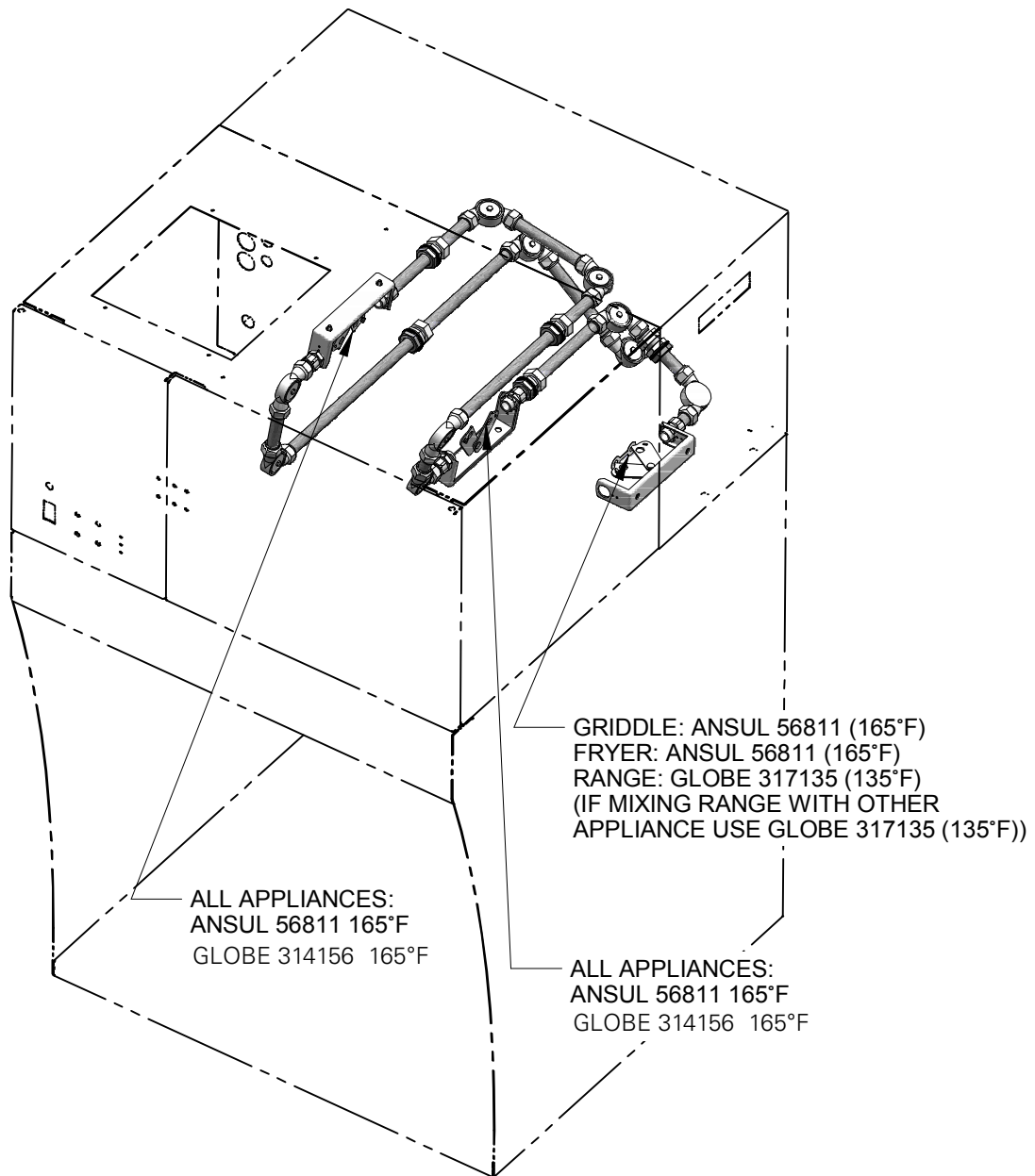

**LINK TEMPERATURE AND LOCATION**

2-05.3. Fire Extinguisher Nozzle Locations

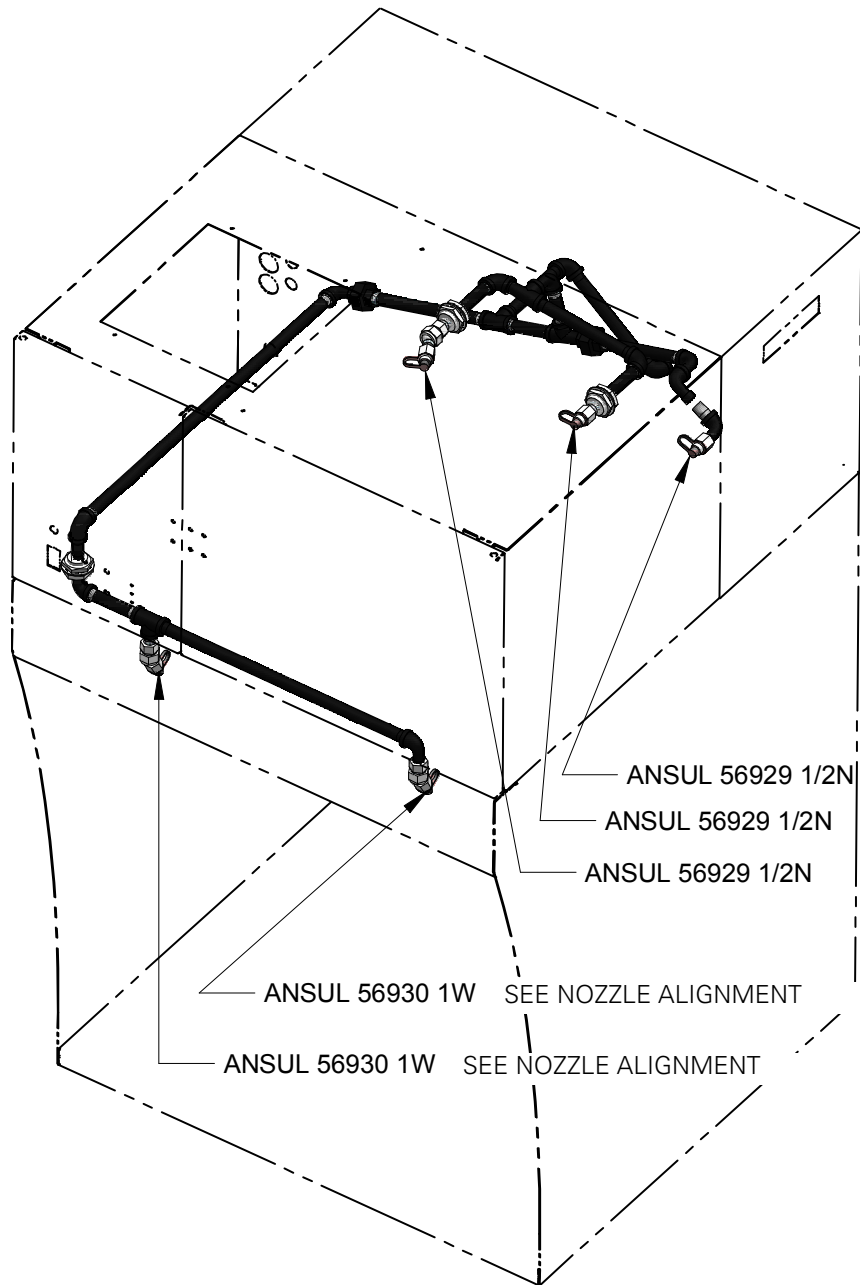

**NOZZLE TYPE AND LOCATION**

**NOTE:**

All nozzles are factory-installed.

## 2-05.4. Fire Extinguisher Nozzle Alignment

Appliance extinguisher nozzles must be aligned as shown for these appliances.

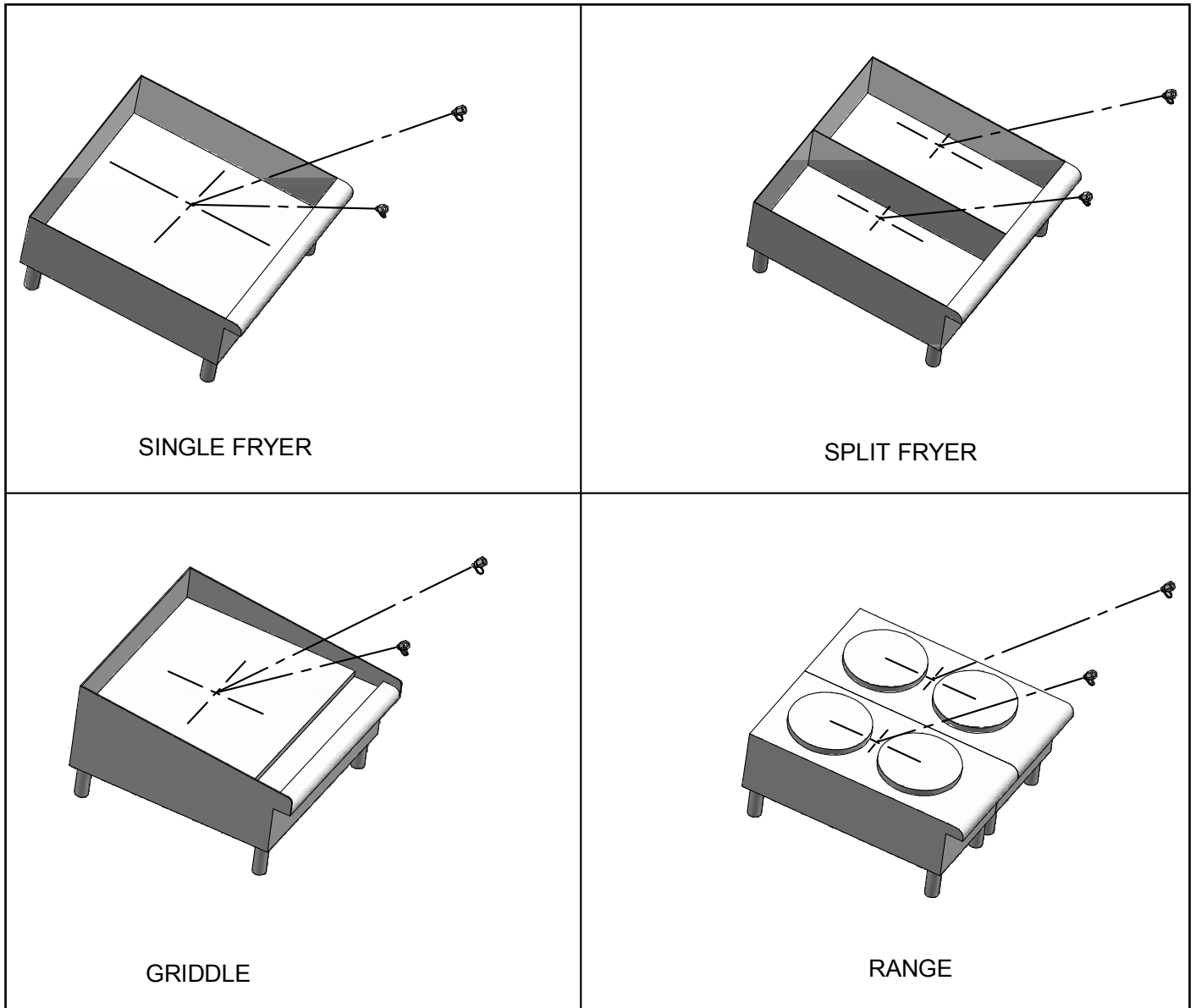

## 2-06. Final Counter-Top Installation, GVH-C

1. Confirm that both the Hood and cooking appliance are properly wired and that installation of the fire suppression system is complete.
2. Ensure that the Hood is located in its final location and that it is suitably level and stable.
3. Two (2) Mounting Brackets are provided for securing the Hood to the counter-top. The brackets, one on each side, can be placed at most any position along the Hood's base, but preferably should be located between the middle to the rear third of the side.
4. Use the supplied #10 x 1/2" self-drilling screws to attach the brackets to the Hood base. Use screws which are appropriate for the counter-top material (not supplied) to fasten the Mounting Brackets to the counter-top.
5. Apply a bead of food-grade silicone around the entire hood base perimeter to create a liquid-tight seal between the base and counter-top surface.
6. The Hood installation must comply with all applicable health and sanitation codes and regulations.

### NOTE:

- Before operating the Hood, remove any remaining protective film from the outer surfaces of the Hood, Skirt and Base, then clean all exterior surfaces with a good quality stainless steel cleaner/polish.

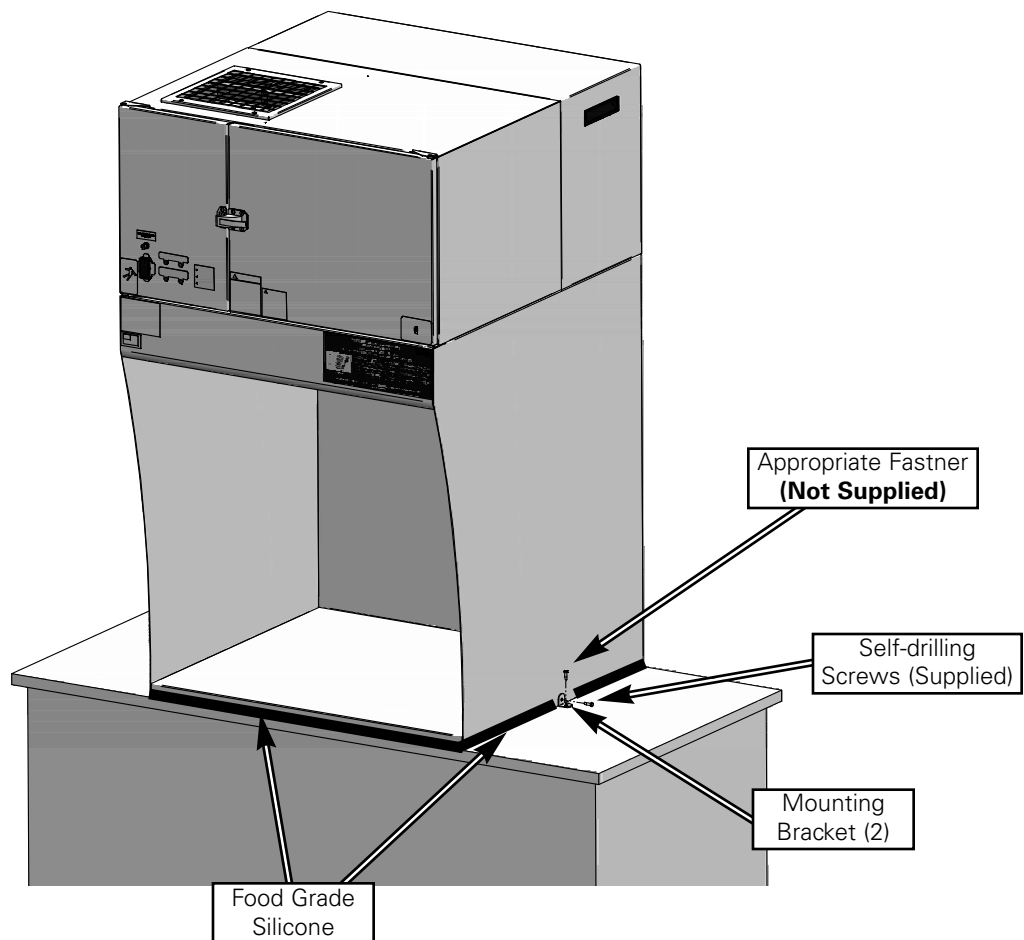



## 3. Overview

The following section provides a brief overview of the components, functions, and accessories of the GVH Ventless Hood. Please review this section carefully before attempting to operate the unit.

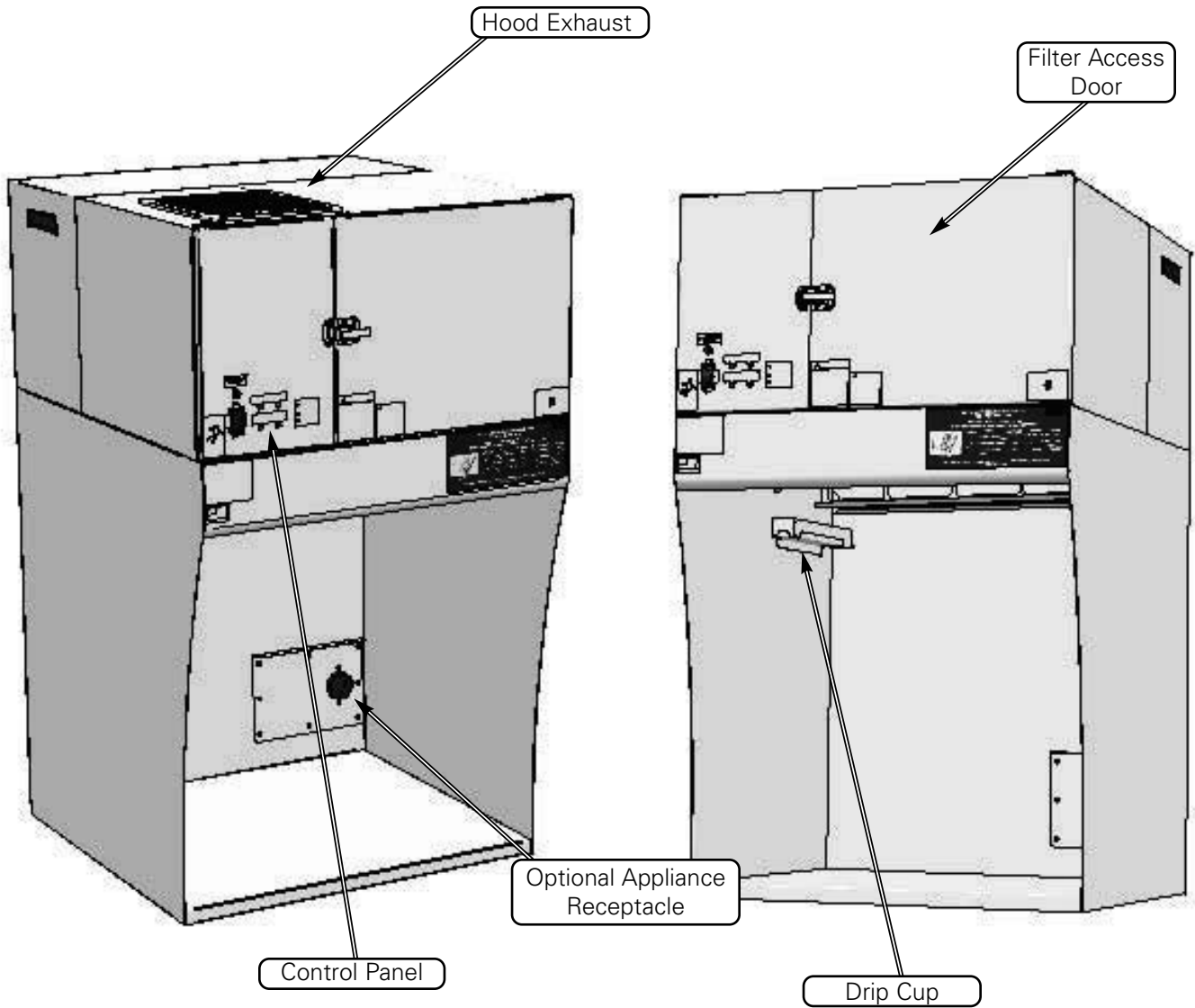

3-01. Control Panel

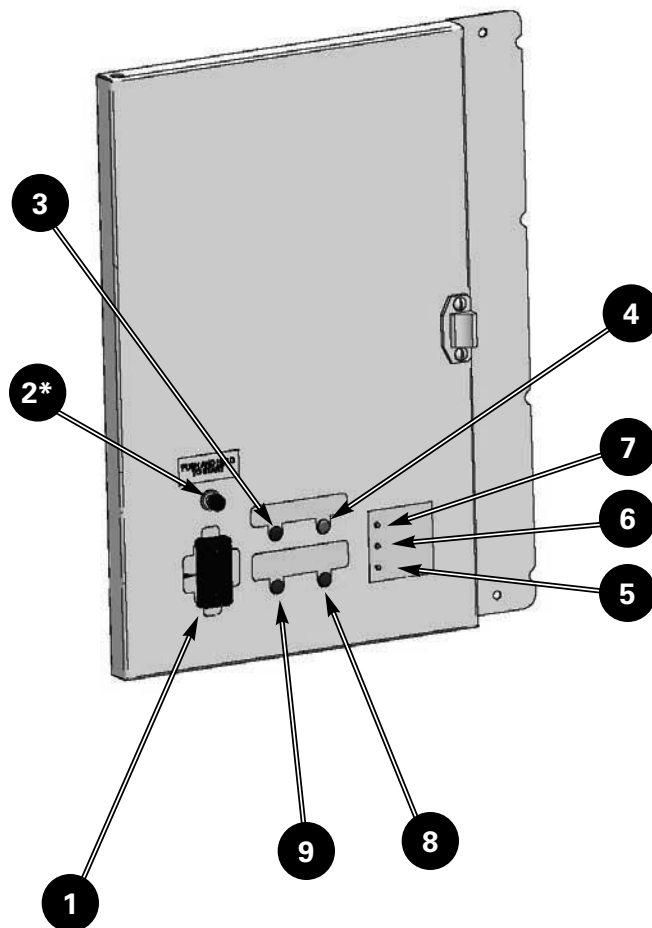

\* ILS Only

3-01. Control Panel		
Item	Description	Function
1	Power Switch	The Power Switch is a two-position Switch. Placing switch in the <b>ON</b> position starts the hood fan and turns on the under-hood light.
2*	<b>PUSH TO START</b> Button	After placing Power Switch in the <b>ON</b> position, push and hold button for approx. 5 seconds to start the hood fan. <b>Only on units with Inter-Locking Start (ILS) option installed.</b>
3	Hood Powered Light	This Light is illuminated when the Power Switch is in the <b>ON</b> position and the Filter Access Door is properly closed. If equipped with the <b>ILS</b> , the start button must have also been depressed.
4	Appliance Powered Light	Light is illuminated to signify that the appliance under the hood is receiving power and ready to turn on for use.
5	<b>ON</b> LED Indicator (EAC)	The <b>ON</b> Indicator Light is illuminated when the Electronic Air Cleaner (EAC) power supply is on. If the EAC is functioning normally, this will be the only LED illuminated.
6	<b>WASH</b> LED Indicator (EAC)	The <b>WASH</b> Indicator Light is illuminated when the EAC becomes excessively dirty. This is <b>NOT</b> a signal for routine cleaning; the EAC must be cleaned <b>daily</b> for best performance. Failure to do so will significantly reduce the life of the charcoal filter and possibly cause damage to the EAC power supply.
7	<b>CHECK</b> LED Indicator (EAC)	The <b>CHECK</b> Indicator Light will illuminate when the EAC cell becomes shorted. The EAC has stopped functioning; an alarm will sound and the cooking appliance will be disabled two (2) minutes after the <b>CHECK</b> light comes on. The EAC must be cleaned or is need of repair or replacement.
8	Clogged Filter Indicator (Baffle or Charcoal)	Light will illuminate if the Baffle Filter or Charcoal Filter is dirty/clogged.
9	Filter Missing Indicator (Baffle or Charcoal)	Light will illuminate if either the Charcoal or Baffle Filter is missing or installed improperly.

\* ILS Only

3-02. Hood Front & Filter Chamber

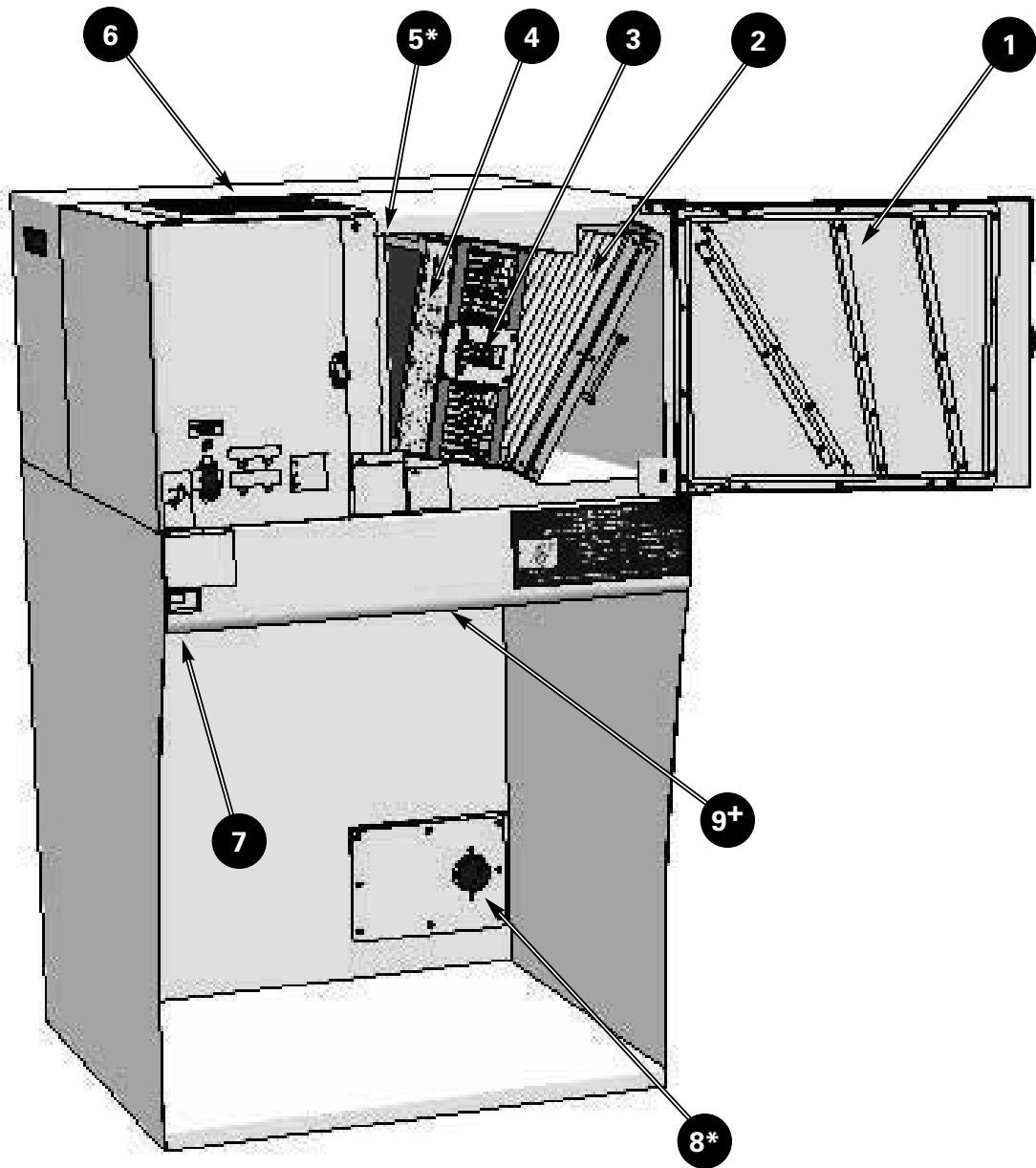

\* Optional  
+ Not Seen

3-02. Hood Front & Filter Chamber		
Item	Description	Function
1	Filter Access Door	Provides access to the Baffle Filter, EAC and Charcoal Filter. This door must be closed and latched for the unit to operate.
2	Baffle Filter	First stage of the grease extraction and air-cleaning system. This filter is easily removed for daily cleaning. <b>To avoid possible electrical shock, DO NOT remove while the hood Power Switch is ON. The Baffle Filter should be cleaned daily.</b>
3	EAC Filter	EAC Filter is an electrostatic device that removes grease vapor and smoke generated during cooking. <b>To avoid possible electrical shock, DO NOT remove while the hood Power Switch is ON. The EAC <u>must</u> be cleaned daily.</b>
4	Charcoal Filter	Charcoal Filter helps to eliminate cooking aromas from the discharge air. This Filter should be replaced monthly. <b>To avoid possible electrical shock, DO NOT remove the Charcoal Filter while the hood Power Switch is ON. NEVER attempt to clean and re-use the Charcoal Filter. Replace with new filter every 30 days.</b>
5*	UV Lamp	Optional 4th stage of air cleaning, helps sanitize discharge air and the hood plenum area to further aid with eliminating cooking aromas. <b>The UV Lamp should be cleaned monthly and replaced annually.</b>
6	Air Exhaust Outlet	The Exhaust Outlet located on top of the unit, exhausts the filtered air back into the room. <b>For proper air flow, a minimum clearance of 18" <u>must</u> be maintained between the top of the hood and the ceiling, or other overhead obstruction.</b>
7	Grease Drip Cup	The Grease Drip Cup catches grease condensate generated at the Baffle Filter. This container must be emptied and cleaned daily.
8*	Appliance Receptacle	Optional interlocked appliance receptacle (NEMA), 50A max. Allows the under-hood appliance to be plugged directly into the hood, eliminating need for separate appliance power supply.
9	Under-Hood Light	Fluorescent lighting illuminates the appliance area under the hood.

\* Optional  
 + Not Seen



**3-03. Accessories (Standard)**

Part	Description/Part Number	Function
	<p>Baffle Filter (Double, Hinged) <b>P/N 41043</b></p>	<p>Removes large particle contaminant from the air stream.</p>
	<p>EAC Filter Assembly <b>P/N 93302</b></p>	<p>Removes smoke and fine particle contaminant from the air stream.</p>
	<p>Charcoal Filter <b>P/N 31964</b></p>	<p>Helps to remove cooking odors from the discharged air.</p>



**3-03. Accessories (Standard)**

Part	Description/Part Number	Function
	<p>EAC Soak Tank P/N 39327</p>	<p>Use for soaking and cleaning EAC filter.</p>

**3-04. Accessories (Optional)**

Part	Description/Part Number	Function
	<p>Ultra-Violet Lamp P/N 90226</p>	<p>Sanitizes discharge air and hood plenum area to aid odor control.</p>



**NOTES:**



## 4. Operation & Filter Maintenance

This section describes Hood operation, care and cleaning of Filters, and other general maintenance items.

### 4-01. Hood Operation

Confirm that all Filters are in place and properly seated before attempting to operate the hood. The Filter Access Door must be in place and secure. **NOTE: The hood will NOT start if the Filter Access Door is not installed or not properly positioned.**

#### 4-01.1 Starting the Hood (Regular)

1. Place the **Power Switch** **1** in the **ON** position.
2. The green **Hood Powered** light **2** will come on.
3. The Hood blower will start.
4. The EAC status **ON LED** **3** will illuminate.
5. The amber **Appliance Powered** light **4** will come on.  
This indicates that power is being supplied to the cooking appliance under the hood. It can now be operated.
6. Should an audible alarm sound, any other indicator lights come on and/or if the **Appliance Powered** light does not turn on, refer to Troubleshooting Sections of this manual.

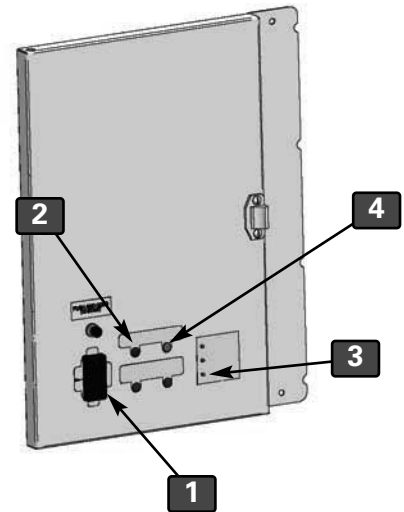

#### 4-01.2 Starting the Hood (ILS Model)

1. Place the **Power Switch** **1** in the **ON** position.
2. Press and hold the **Push to Start** Button **2** for approx. 5 seconds.
3. The green **Hood Powered** light **3** will come on.
4. The Hood blower will start.
5. The EAC status **ON LED** **4** will illuminate.
6. The amber **Appliance Powered** light **5** will come on.  
This indicates that power is being supplied to the cooking appliance under the hood. It can now be operated.
7. Should an audible alarm sound, any other indicator lights come on and/or if the **Appliance Powered** light does not turn on, refer to Troubleshooting Sections of this manual.

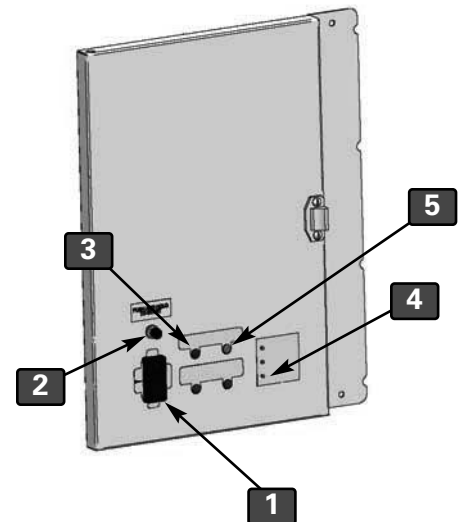

**4-02. Hood Filter System**

The GVH Hood Filter System consist of three (3) stages. This section describes filter maintenance and cleaning procedured necessary to keep the air cleaning system at peak performance.

**4-02.1. Ventless Hood Filter Table**

<b>Filter</b>	<b>When to clean or replace</b>	<b>How to remove</b>	<b>How to clean</b>	<b>How to install</b>
Baffle Filter	Clean daily	Section 4-02.02.	Section 4-03.01.	Section 4-02.03.
EAC Filter	Clean daily	Section 4-02.02.	Section 4-03.02.	Section 4-02.03.
Charcoal Filter	Replace every 30 days	Section 4-02.02.	<b>Never clean, Replace Only</b> Section 4-03.03.	Section 4-02.03.
Ultra-violet Lamp (if equipped)	Clean every 30 days Replace annually	NA	Section 4-03.04	NA

## 4-02.2. Filter Removal - Baffle, EAC & Charcoal

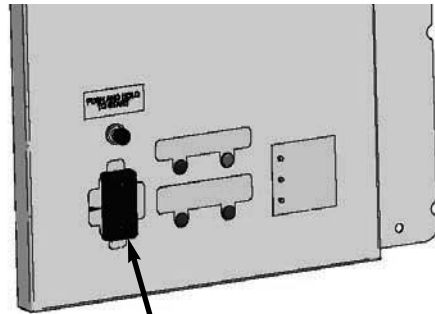

**1** Place in OFF position

**2** Remove Filter Access Door

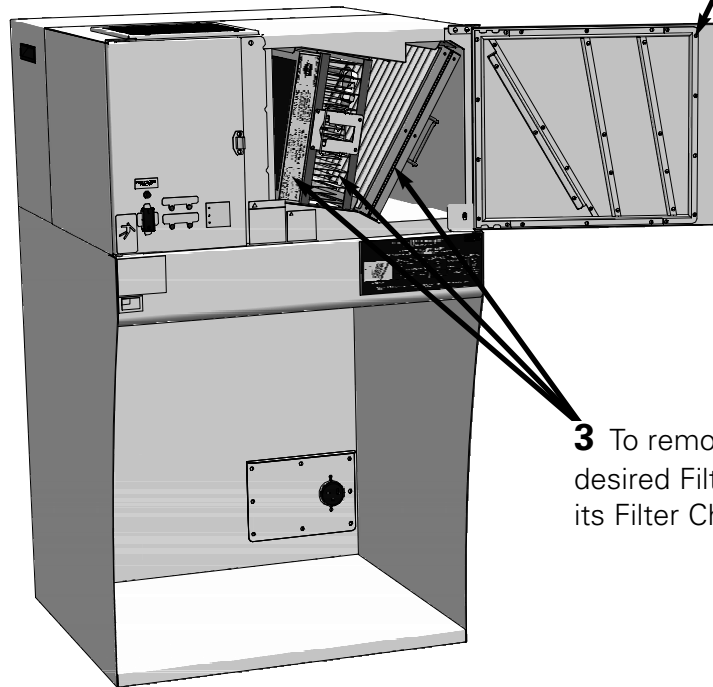

**3** To remove, simply slide the desired Filter straight out of its Filter Chamber track.

## 4-02.3. Filter Installation - Baffle, EAC & Charcoal

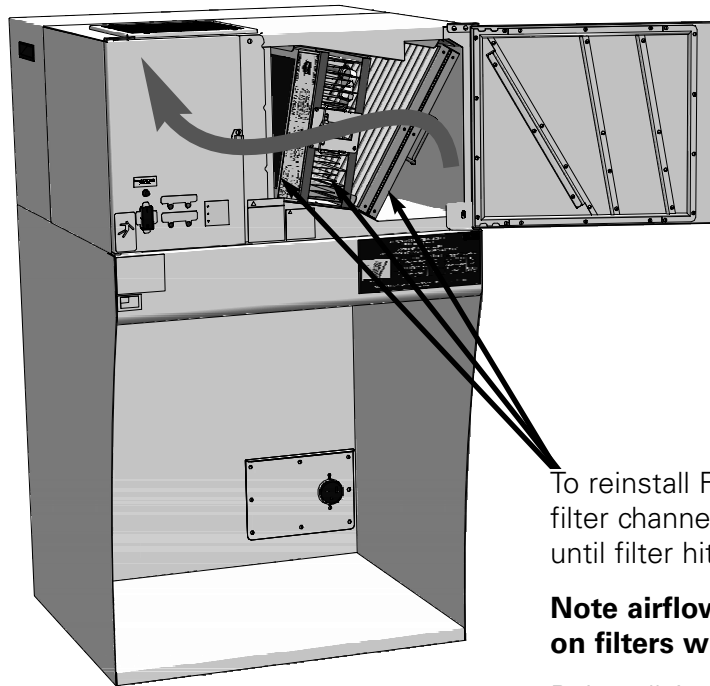

To reinstall Filters, align with the filter channel and slide straight in until filter hits a stop.

**Note airflow direction arrows on filters when reinstalling.**

Reinstall Access Door

## 4-02.4. Charcoal or Baffle Filter Missing

If the Baffle or Charcoal Filter is missing, or not positioned correctly, the **Charcoal or Baffle Filter Missing** light **1** will illuminate and power to the cooking appliance under the hood is interrupted until the condition is corrected. The amber **Appliance Powered** light will turn **OFF**.

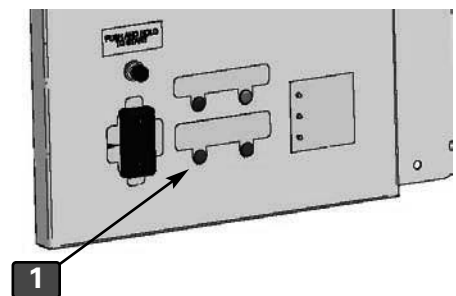

## 4-02.05. EAC Filter Missing

If the EAC Filter is missing or not properly positioned, all 3 EAC LED's **2** will illuminate; after approx. 2 minutes an intermittent tone alarm will sound and power to the cooking appliance under the hood is interrupted until the condition is corrected. The amber **Appliance Powered** light will turn **OFF**.

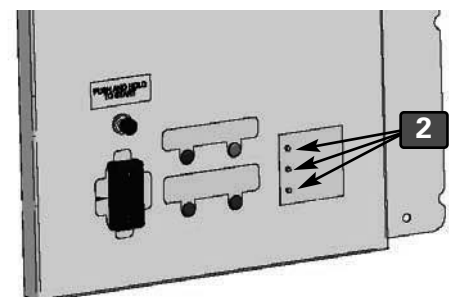

## 4-02.6. EAC Filter Status

Three L.E.D. indicator lights on the Control Panel display the status of the EAC Filter System.

- 1 ON** When this is the only L.E.D. **ON**, the EAC Filter is in place, powered and operating properly.
- 2 WASH** When **ON**, indicates the collection fins are becoming excessively dirty and must be cleaned. After approx. 2 minutes in this condition, an intermittent tone alarm will sound and power to the interlocked under-hood cooking appliance will be interrupted until the condition is corrected. The amber **Appliance Powered** light will turn **OFF**.
- 3 CHECK** When **ON**, indicates the Filter is not operating. There is either a poor connection at the contacts or the filter is extremely dirty or damaged. After approx. 2 minutes in this condition, an intermittent tone alarm will sound and power to the interlocked under-hood cooking appliance will be interrupted until the condition is corrected. The amber **Appliance Powered** light will turn **OFF**.

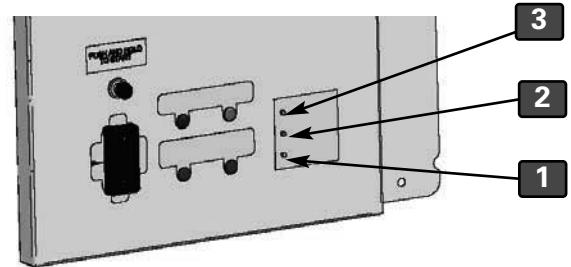

### !! IMPORTANT NOTE

- **The WASH L.E.D. is not to be use as an indicator signal for routine cleaning of the EAC cell. The EAC must be cleaned daily to maintain peak performance. The WASH light being ON is an indication that the cell is too dirty to function and that power to the cooking appliance is about to be shutdown.**

## 4-03. Filter Maintenance

### 4-03.1. Baffle Filter Cleaning

Grease Baffle Filter should be cleaned daily. Place in sink and clean with a mild, bio-degradable, degreaser. Dry filter thoroughly and reinstall in the unit. Generally, the Baffle Filter may be washed in a dishwasher.

**Ensure that Baffle Filter is thoroughly dry before reinstalling in the hood. NEVER PLACE A WET FILTER INTO THE HOOD!**

The EAC Filter **must** be cleaned daily for peak performance. Failure to do so will eventually lead to filter system failure and reduce Charcoal Filter life. Follow the procedure below for effective cleaning.

**The EAC cell is NOT designed to withstand washing in commercial dishwashers.**

### CAUTION

- **Do not bend the fins or break the ionizer wires on the EAC as this will prevent the collecting cell from performing properly and potentially void the warranty.**

1. Add 1/2 gal. of a mild degreaser, such as **Simple Green** or **Clear Magic**, to the provided Soak Tank **1** ... add water to the fill line marked by X's on the inside of the tank back and mix thoroughly.
2. Grasp the cell's contact plate **2** and carefully lower the EAC **3** into the mixed degreasing solution.
3. Allow the EAC to soak for 30 minutes. After that time, grasp the cell by the contact plate **2**, lift it and agitate up and down in the solution several times to dislodge grease residue.
4. Carefully remove the EAC from the tank and rinse thoroughly in a sink using hot water spray.
5. Stand cell on end with contact plate up and allow to air dry overnight.
6. Inspect cell for broken wires or bent fins. Any broken wires need to be replaced promptly. Bent fins may be gently straightened by hand, if needed.

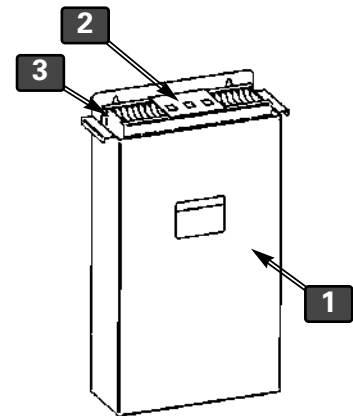

- **With proper care, cleaning, and handling, the EAC cell is designed to provide years of service. It is important that it be cleaned daily as described above.**

## 4-03.3. Charcoal Filter Maintenance

### WARNING

- **NEVER attempt to clean and re-use the Charcoal Filter. Damage to the unit could result.**

The Charcoal Filter cannot be cleaned ... it is to be replaced **ONLY**.

**Replace the Charcoal Filter every 30 days using replacement Part No. 31964.** It is advised that the installation date be recorded in the space provided on the new filter's label.

## 4-03.2. UV Lamp Cleaning (If Equipped)

### **CAUTION**

- **DO NOT** touch or handle the glass portion of the UV Lamp with bare hands. This will greatly reduce the life of the bulb.

It is recommended to clean the UV Lamp every 30 days.

1. Place hood Power Switch **1** in the **OFF** position.
2. Open Filter Access Door **2**.
3. The UV Lamp **3** protrudes through the rear wall of the hood and extends into the plenum area. It is not necessary to remove the lamp to clean it.
4. Remove the Charcoal Filter and EAC Filter, if needed.
5. Lightly spray a mild, non-caustic, bio-degradable degreaser, such as **Simple Green** onto the UV lamp. Allow it to soak for a few seconds and then wipe off residue with a dry, lint free cloth. **DO NOT TOUCH THE LAMP'S GLASS BULB WITH BARE HANDS.**
6. Reinstall filters, if removed, and close Filter Access Door.
7. Restart hood as described in **Section 4-01.1 or 4-01.2.**

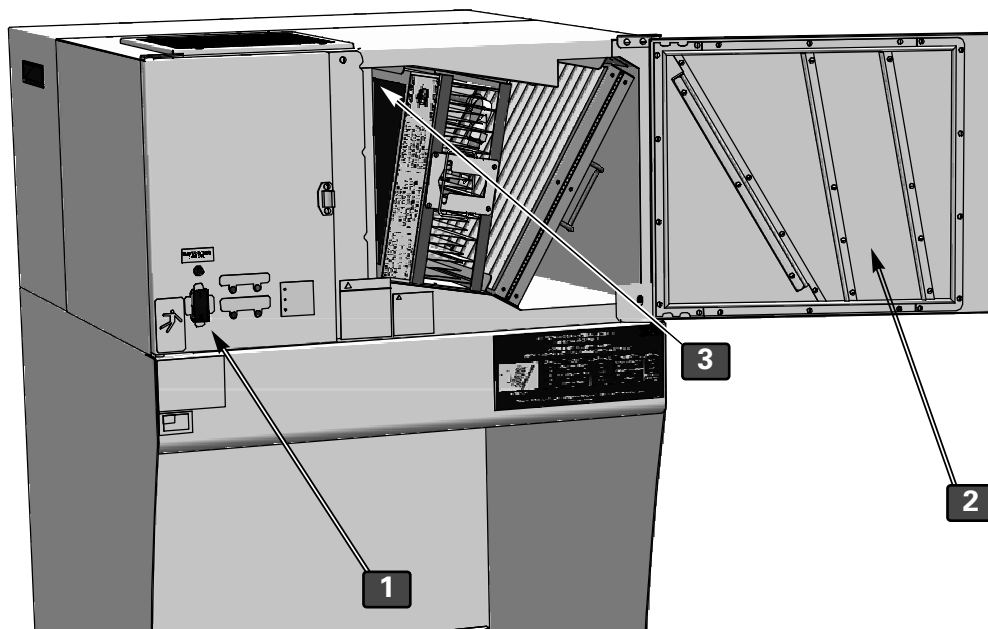

## 4-03.2. Replacing the UV Lamp (If Equipped)

The UV Lamp must be replaced annually to maintain peak performance, as well as if it is broken or burned out.

1. Place hood Power Switch in the **OFF** position.
2. Remove screws and carefully lift off the Rear Hood Cover **1**.
3. Carefully unplug the lead **2** of the old lamp from the ballast lead.
4. Remove the two (2) retaining nuts securing the UV Sealing Channel **3** to the hood back.
5. Pull the old lamp from the hood plenum and remove the Sealing Channel..
6. When handling the new lamp, **DO NOT TOUCH THE GLASS BULB WITH BARE HANDS.** Unwrap new lamp; be certain the o-ring **4** is in place on the white socket. It must be against the flange toward the bulb.
7. Slide the Sealing Channel over the cord and seat it against the socket flange.
8. Place the new lamp through the hole **5** on the hood back and insert fully until the o-ring is seated against the wall. Reinstall retaining nuts to secure channel and lamp.
9. Plug Lamp lead into ballast lead and secure excess wire.
10. Restart hood as described in **Section 4-01.1 or 4-01.2.**

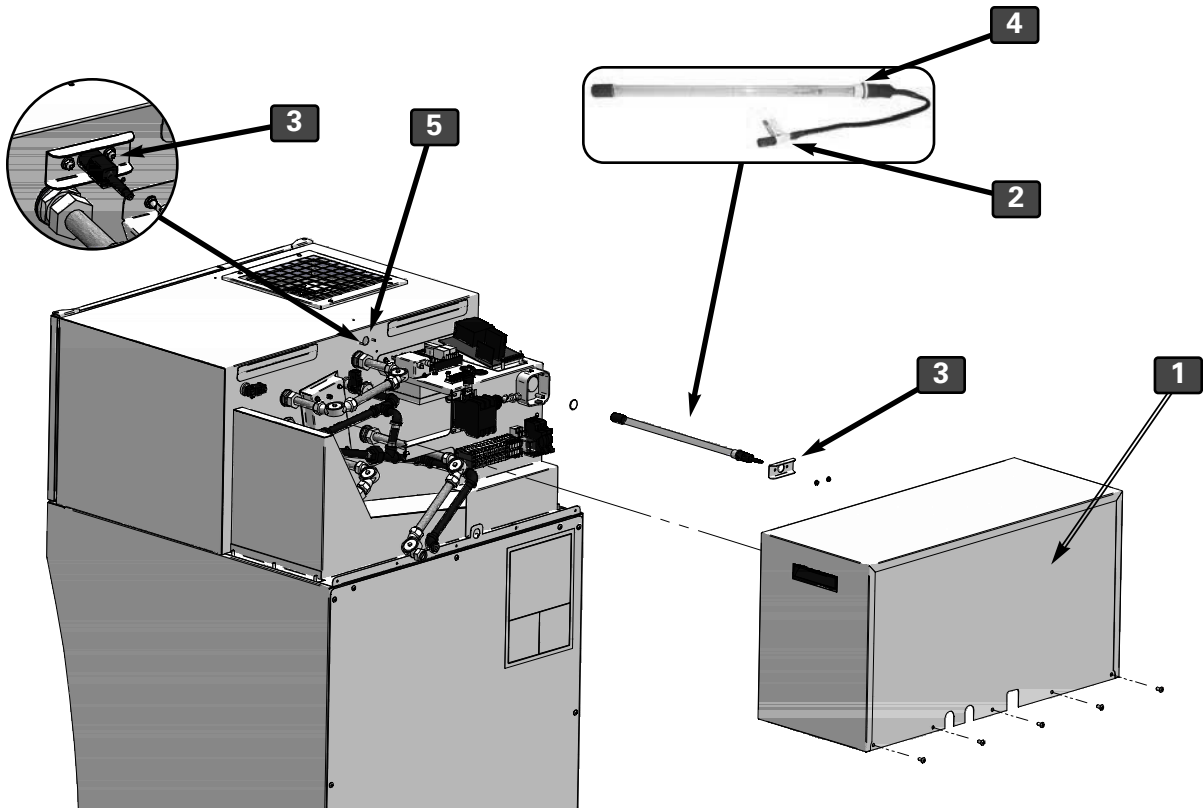



## 4-04. Filter Alarm Chart

Alarm Sound	What will happen	Filter affected	Cause	Solution	See Section
Continuous tone	Alarm sounds, <b>Charcoal or Baffle Filter Clogged</b> lamp illuminates, and power to the appliance is shutdown. <b>Appliance Powered</b> light is <b>OFF</b> .	Charcoal	Filter dirty or otherwise clogged	Replace Filter	4-02.02. & 4-02.03.
Continuous tone	Alarm sounds, <b>Charcoal or Baffle Filter Clogged</b> lamp illuminates, and power to the appliance is shutdown. <b>Appliance Powered</b> light is <b>OFF</b> .	Baffle	Filter dirty or otherwise clogged	Remove and clean Filter	4-02.02. 4-02.03. & 4-03.01.
Intermittent tone	<b>Check</b> and/or <b>Wash</b> LED's are illuminated, alarm sounds and after approx. 2 minutes, power to the appliance is shutdown. <b>Appliance Powered</b> light is <b>OFF</b> .	E.A.C.	Filter dirty or damaged	Clean Filter. Replace or repair Filter if needed	4-02.02. 4-02.03. & 4-03.02.

## 4-05. Replacing Under-Hood Fluorescent Light

1. Place hood Power Switch **1** in the **OFF** position; **ensure that the cooking appliance(s) under the hood is adequately cool before attempting to replace bulb.**
2. Remove retaining screws from the Light Cover Assembly **2** and remove.
3. Remove the old fluorescent bulb **3**, replace with new, T5 - 14W - 22" fluorescent tube (**Giles P/N 20616**).
4. Replace Light Cover Assembly.
5. Restart hood as described in **Section 4-01.01 or 4-01.02**

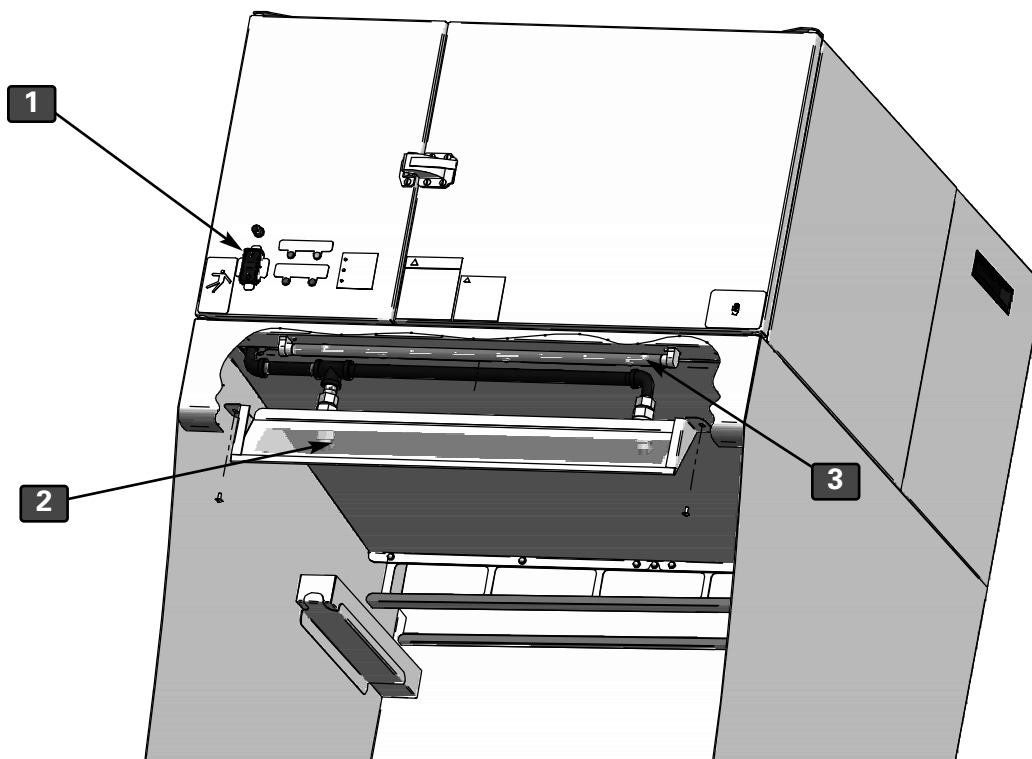

## 5. Hood Cleaning & Maintenance

This Section describes the steps to generally maintain and clean the GVH Hood system. Attention to these procedures will help ensure the hood remains in good operating condition and continues to run efficiently and safely.

A **Maintenance & Service Log** is provided in this manual, see Table 5.6.

### 5-01. Monthly Interlock Check

The Hood design incorporates various interlock devices to ensure that the unit will shutdown in the event that certain conditions exist that are not consistent with safe and effective operation. These interlocks should be tested MONTHLY as described below. Use the **Maintenance & Service Log** and place a check in the box that corresponds to each functional test. If a problem is found, contact a service provider.

1. **Door Interlock Check:** Turn power switch **ON**. With Hood running, unlatch and slightly open the Filter Access door. Confirm Hood powers off when door is opened. Check the under-hood appliance to ensure that it cannot be turned on.
2. **Baffle Filter Check:** Place power switch in the **OFF** position, open Access Door and remove the Baffle Filter. Close door and turn power **ON**. The red **Baffle or Charcoal Filter Missing** light should illuminate and the **Appliance Powered** light should be **OFF**. Check the under-hood appliance to ensure that it cannot be turned on. Turn power **OFF** and reinstall the Baffle Filter.
3. **EAC Filter Check:** Place power switch in the **OFF** position, open Access Door and remove the EAC Filter. Close door and turn power **ON**. All three EAC status LED's should illuminate and after approximately 2 minutes, an intermittent tone (beeping) alarm should sound. The **Appliance Powered** light should turn **OFF**. Check the under-hood appliance to ensure that it cannot be turned on. Turn power switch **OFF** and reinstall EAC Filter.
4. **Charcoal Filter Check:** Place power switch in the **OFF** position, open Access Door and remove the Charcoal Filter. Close door and turn power **ON**. The red **Baffle or Charcoal Filter Missing** light should illuminate and the **Appliance Powered** light should be **OFF**. Check the under-hood appliance to ensure that it cannot be turned on. Turn power **OFF** and reinstall the Charcoal Filter.
5. **Filter Clogged Check:** Perform this check ONLY after installing a new Charcoal Filter. The easiest method for checking the clogged filter interlock is to completely cover the hood's exhaust outlet with piece of cardboard while the hood is running and the appliance power is **ON**. A continuous tone alarm should sound as the exhaust is covered, the red **Baffle or Charcoal Filter Clogged** light should illuminate and the **Appliance Powered** light should turn **OFF**. The appliance should also turn **OFF** during this time. Remove the obstruction; the alarm should silence and power should be restored to the appliance. If the alarm tone does not sound, fails to silence, or the appliance fails to turn **OFF** or turn **ON**, contact a service agent to have the Clogged Filter interlock checked.

## 5-02. Quarterly Hood Cleaning

### CAUTION

- DO NOT** wash down hood with water from a spray hose.
- DO NOT** steam clean or use any type pressure washer.
- DO NOT** use products containing chlorine or other caustic chemicals.
- DO NOT** use abrasive products, steel wool or scouring pads.

To maintain effectiveness and performance, the hood must be cleaned, at a minimum, every 3 months.

1. Disconnect power to the unit, preferably at a breaker.
2. If possible, disconnect and remove the under-hood appliance.
3. Remove all filters from the hood.
4. Using a soft cloth, sponge, or towel and a mild bio-degradable degreaser, clean the entire hood plenum and blower section to remove grease film accumulation from interior surfaces. Inspect the hood fan and clean any grease build-up from the fan blades.
5. Thorough clean the under-hood area and all exterior surfaces with mild degreaser or a good quality stainless steel cleaner.
6. Allow hood to thoroughly dry or wipe dry with clean dry cloth.
7. Clean filters as needed and replace.
8. Restore supply power to hood.

## 5-03. Fire Suppression System Maintenance

The fire extinguishing system should be maintained as outlined in the **Standard for Wet Chemical Extinguishing Systems, NFPA 17A** and in accordance with the instructions of the system's installer.

Please contact a local Authorized Fire Protection Company or Agent for all system maintenance, necessary troubleshooting and/or repairs.

General Maintenance of the fire suppression system is very important. Inspection and servicing is to be performed by qualified fire protection professionals. Required maintenance activities are described in the subsequent sub-sections.

**Consult the Fire Suppression System documentation provided by the system installer for complete maintenance guidelines.**

## 5-03.1. Semi-Annual Fire Suppression System Maintenance

Servicing and inspection of the fire suppression system must be performed by qualified and certified Fire Protection Equipment specialists. As a minimum, field inspection of the Fire Suppression System must be conducted semi-annually. Such maintenance shall consist of the following:

1. Confirm that the fire hazard potential has not changed.
2. Inspect suppressant storage tank for fill level and charge pressure. Inspect and test release mechanism.
3. Check all nozzles to ensure they are free of grease build-up. Confirm that all nozzle caps are in place and in good condition; replace as needed. See **Section 2-05.03, Fire Extinguisher Nozzle Locations**.
4. Test and inspect the remote manual pull station for activation and wear.
5. Install test link and cut to simulate automatic actuation.
6. Clean and inspect fusible links. Confirm all fusible link temperature ratings are correct for the appliance(s) under the hood. See **Section 2-05.2, Fire Suppression Fusible Link Specifications & Location**.
7. Inspect fusible link conduit and wire cable for wear at pulleys and detectors; replace if necessary.
8. Record maintenance date and service performed in a permanent file, and sign-off on tag attached to system.

## 5-03.2. Annual Fire Suppression System Maintenance

Same as Semi-Annual Maintenance except that all fusible links must be replaced with new. See **Section 2-05.2, Fire Suppression Fusible Link Specifications & Location**

## 5-03.3 12-Year Fire Suppression System Maintenance

Same as Annual Maintenance except for the following:

1. Replace fire suppressant chemical.
2. Hydrostatic testing of the suppressant holding tank and charging cartridge. Acceptable to replace with new components that have current hydrostatic certification.
3. Flow test the regulator.

**5-04. Maintenance & Service Log**

Check								Initial/Date	Check								Initial/Date				
✓	✓	✓	✓	✓				<i>ABC</i>	1/31/12	1	2	3	4	5							
1	2	3	4	5						1	2	3	4	5							
1	2	3	4	5	6					1	2	3	4	5	6						
1	2	3	4	5						1	2	3	4	5							
1	2	3	4	5	6	7*	8*			1	2	3	4	5	6	7*	8*				
1	2	3	4	5						1	2	3	4	5							
1	2	3	4	5	6					1	2	3	4	5	6						
1	2	3	4	5						1	2	3	4	5							
1	2	3	4	5	6	7*	8*			1	2	3	4	5	6	7*	8*				
1	2	3	4	5						1	2	3	4	5							
1	2	3	4	5	6					1	2	3	4	5	6						
1	2	3	4	5						1	2	3	4	5							
1	2	3	4	5	6	7*	8*			1	2	3	4	5	6	7*	8*				
1	2	3	4	5						1	2	3	4	5							
1	2	3	4	5	6					1	2	3	4	5	6						
1	2	3	4	5						1	2	3	4	5							
1	2	3	4	5	6	7*	8*			1	2	3	4	5	6	7*	8*				
1	2	3	4	5						1	2	3	4	5							
1	2	3	4	5	6					1	2	3	4	5	6						
1	2	3	4	5						1	2	3	4	5							
1	2	3	4	5	6	7*	8*			1	2	3	4	5	6	7*	8*				
1	2	3	4	5						1	2	3	4	5							
1	2	3	4	5	6					1	2	3	4	5	6						
1	2	3	4	5						1	2	3	4	5							
1	2	3	4	5	6	7*	8*			1	2	3	4	5	6	7*	8*				

1	Door Check	Section 5-1.
2	Baffle Filter Check	Section 5-1.
3	EAC Filter Check	Section 5-1.
4	Charcoal Filter Check	Section 5-1.
5	Filter Clogged	Section 5-1.
6	Quarterly Cleaning	Section 5-2.
7*	Fire Suppression System	Section 5-3.
8*	Fire Suppression System replace Fusible Links	Section 5-4.

**\* Must be performed by a certified, qualified Fire Protection Equipment Company.**

# Hood Cleaning & Maintenance

Model: GVH-C, GVH-F



Notes:

## 6. *Trouble-Shooting*

This section describes basic troubleshooting procedures for the GVH Hood. The wiring diagram attached inside the back cover is provided to assist qualified technicians with more in-depth troubleshooting.

**⚠ DANGER**

- Troubleshooting for electrical problems should be performed **ONLY** by a qualified service technician or electrician. Serious injury, or even death, will result from contact with energized electrical components.
- Failure to comply with these **DANGER** notices can result in death or serious injury, equipment or property damage, and possibly void the warranty.

### 6-01. Troubleshooting Procedures

Problem	Probable Cause	Corrective Action
<b>Hood will not turn on</b>	a. Filter Access Door not closed	Close & latch Access Door.
	b. <b>On ILS Model</b> "PUSH TO START" button not held for at least 5 seconds	Hold down "PUSH TO START" button for 5 secs.
	c. Power Switch is faulty	Replace Power Switch.
	c. Improper supply voltage	Connect to proper electrical supply.
	e. Not properly connected to power source.	Confirm connections & correct.
	f. Blown fuse or tripped circuit breaker.	Check fuse in hood and main breaker box.
<b>Charcoal or Baffle Filter Missing light illuminated at Initial Start-up</b>	a. Baffle Filter is not installed or not properly seated	Install Baffle Filter and/or check alignment in track.
	b. Charcoal Filter is not installed or not properly seated	Install Charcoal Filter and/or check alignment in track.
<b>CHECK and/or WASH LED illuminated &amp; intermittent (beeping) alarm sounding</b>	a. EAC shorted (damaged)	Replace or repair the EAC cell.
	b. EAC dirty	Clean the EAC cell.
	c. EAC high voltage power supply is faulty.	Replace high voltage power supply.
	d. High voltage wires shorted to ground.	Correct shorted condition.
	e. Faulty EAC contact plate	Replace contact plate.



## 6-01. Troubleshooting Procedures (Continued)

Problem	Probable Cause	Corrective Action
<b>Appliance will not heat ...</b> • Hood Powered light <b>ON</b> • FILTER MISSING light <b>ON</b> • APPLIANCE POWERED light <b>OFF</b>	a. Baffle Filter missing or not properly installed	Install Baffle Filter or check alignment.
	b. Baffle Filter missing or not properly installed	Install Charcoal Filter or check alignment.
	c. Filter switch(es) faulty	Replace Filter switch(es).
<b>Appliance will not heat ...</b> • Hood Powered light <b>ON</b> • FILTER CLOGGED light <b>ON</b> • APPLIANCE POWERED light <b>OFF</b> • Continuous tone alarm sounding	a. Baffle or Charcoal Filter clogged	Replace Charcoal Filter or clean Baffle Filter.
	b. Hood exhaust outlet excessively block	Confirm exhaust is clear and min. clearance requirement is met.
	c. Vacuum Switch (clogged filter sensor) is out of adjustment	Have vacuum switch adjusted.
	d. Kinked or blocked vacuum line	Remove vacuum line kinks or blockage.
	e. Fan running slow or blades are loaded with grease film	Check voltage and inspect blower, clean if needed
<b>Appliance will not heat ...</b> • Hood Power light <b>ON</b> • CHECK and/or WASH LED's <b>ON</b> • APPLIANCE POWERED light <b>OFF</b> • Intermittent tone (beeping) alarm sounding	a. EAC is shorted	Repair or replace EAC cell.
	b. EAC excessively dirty	Clean EAC cell.
	c. EAC power supply is faulty	Replace EAC power supply.
	d. EAC wires shorted to ground	Check voltage, check wiring.
	e. Contact Plate is faulty	Replace Contact Plate.
	f. EAC driver board is faulty	Replace EAC driver module.
	g. Too many EAC ionizer wires broken or missing	Replace ionizer wires.
	h. EAC cell is not installed	Install clean EAC cell.
<b>Under-hood lighting does not come on when Power Switch is placed in ON position</b>	a. Fluorescent bulb burned out	Replace bulb.
	b. Ballast is faulty	Replace ballast.
	c. Fuse is blown	Check and replace fuse.

## **7. Parts List**

This section lists the various field-replaceable parts available for the GVH Hood.

### **7-01. Parts Ordering and Service Information**

If you require assistance or need repairs, please contact a Giles Manufacturer’s Representative or Dealer to assist with locating an authorized service provider in your area. For further assistance, please contact Giles Enterprises directly at the following phone numbers:

**IN THE UNITED STATES, CANADA or MEXICO**

Call **800.554.4537** during normal business hours, 8:00 AM to 5:00 PM Central Time; other than normal business hours, call **800.554.4537** and follow recorded prompts to reach after-hours support.

**IN ALL OTHER COUNTRIES**

Call **334.272.1457** during normal business hours, 8:00 AM to 5:00 PM Central Time; other than normal business hours, call **334.272.1457** and follow the recorded prompts.

**INTERNET**

Please visit our website at: [www.gfse.com](http://www.gfse.com) or e-mail [services@gfse.com](mailto:services@gfse.com).

The goal of the Giles team is to provide you with the highest quality service and assistance possible. To help us accomplish this please have the following information readily available when calling, along with the nature of the problem you are encountering. This information is recorded on a Serial Plate or Label attached to the unit.

**Record information here for quick future reference.**

**Model Name:** \_\_\_\_\_

**Serial Number:** \_\_\_\_\_

**Voltage:** \_\_\_\_\_

**Phase:** \_\_\_\_\_

**Date unit was installed:** \_\_\_\_\_

# Parts List

Model: GVH-C, GVH-F



7-02. Rear Electrical Components

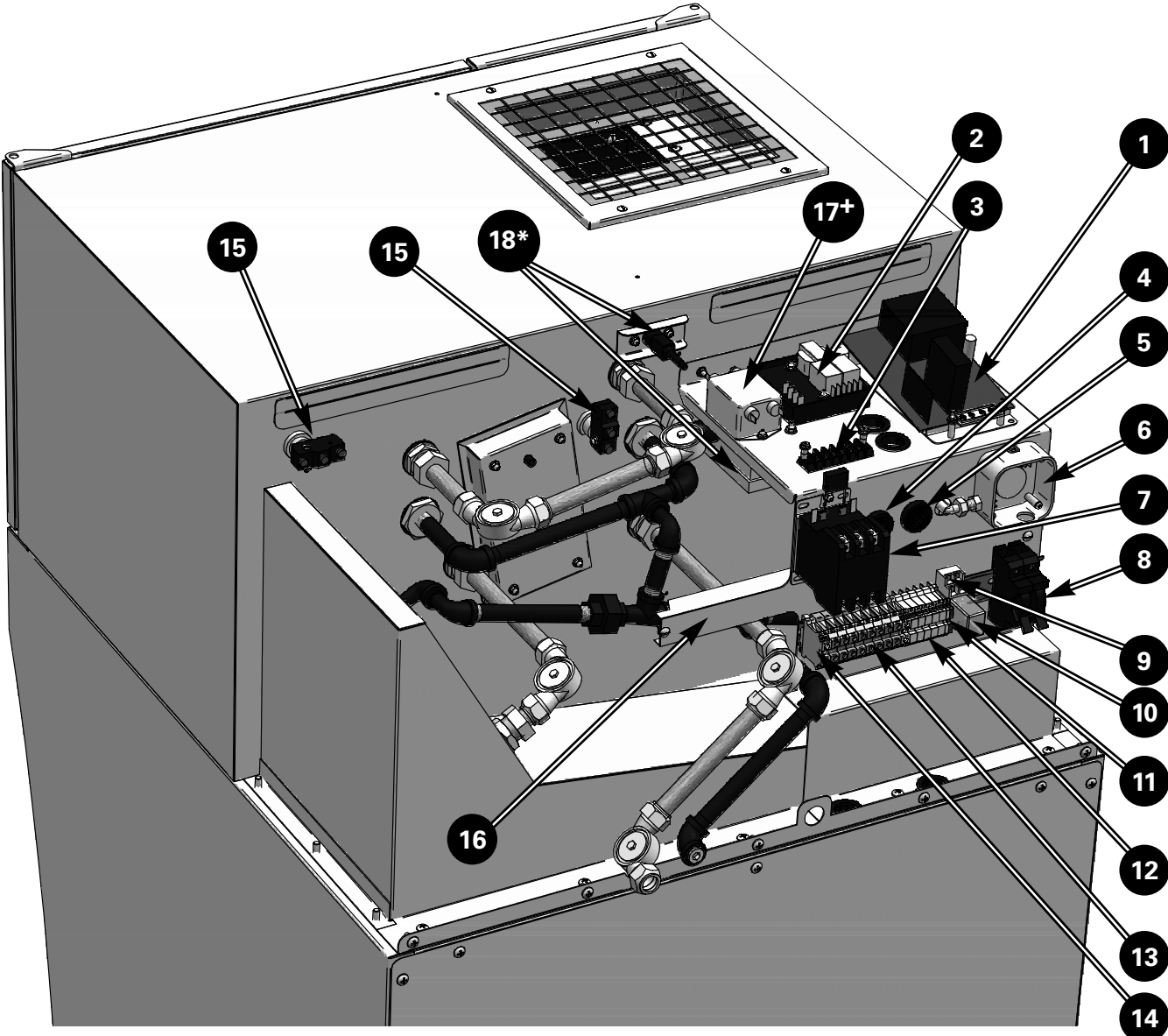

+ CE Model Only  
\* UV Model Only

## 7-02. Parts List for Rear Components

Item	Part No.	Qty.	Description
1	24208	1	EAC POWER SUPPLY, w/DRIVER BOARD, 208-240V
2	23776	1	ALARM & SHUTDOWN MODULE, AIR FILTER
3	23751	1	TERMINAL BLOCK, MA106
4	23782	1	SONALERT, CONTINUOUS TONE, 250V
5	22950	1	SONALERT, 250V, INTERMITTENT
6	20473	1	SWITCH, VACUUM, DUNGS, 0.4 > 4.0 WC
7	32208	1	CONTACTOR, ASSY, 208/240VAC, 3PH
8	20411	2	FUSE HOLDER, DIN RAIL, 600V, 35A
9	20312	1	BASE, RELAY, PLUG-IN, DIN MOUNT
10	20318	1	RELAY, 240 VAC, 10A, ELECTRO-MECH
11	20320	1	TERMINAL BLOCK, GROUND, AWG 8-24
12	20319	5	TERMINAL BLOCK, 50 AMP, AWG 8-24
13	20669	8	TERMINAL BLOCK, 73 AMP, AWG 6-20
14	20318	1	TERMINAL BLOCK GROUND, 73 AMP, AWG 6-20
15	24237	2	SWITCH, PLUNGER, 250V, 15A
16	20607	1	BALLAST, T5, 1-2 BULB, 35W, 120/277V
17 <sup>+</sup>	20397	1	LINE FILTER, INCOMING POWER, 10A
18*	20373	1	UV-LAMP, ASSY, 16-IN, AQUASEAL W/BALLAST
18*	20374	1	UV-LAMP, 16-IN REPLACEMENT BULB ONLY

<sup>+</sup> CE Model Only

\* UV Model Only

7-03. Front View, Filter and Fan Compartment

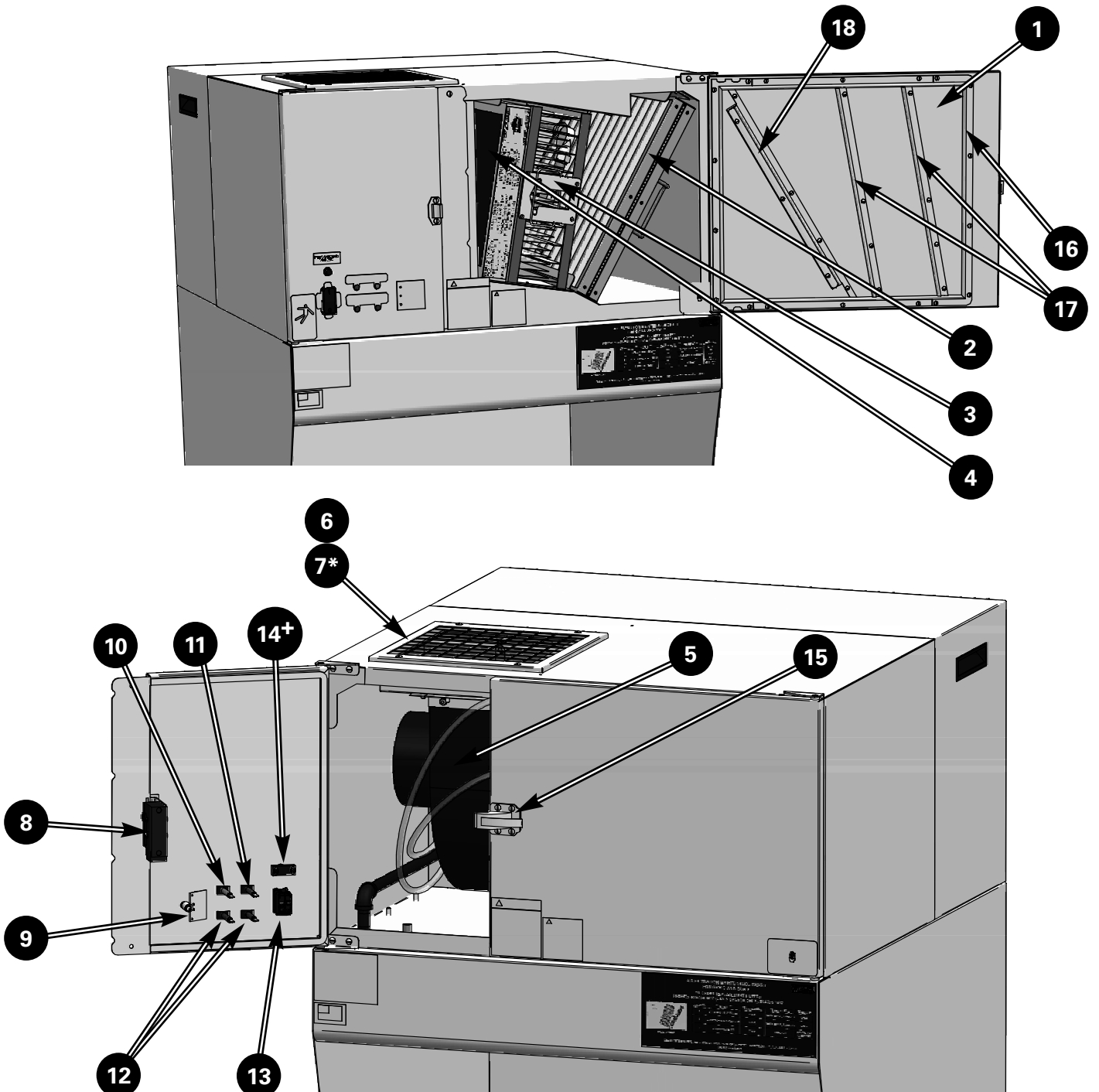

\* Not shown  
+ ILS Model Only

## 7-03. Parts List for Filter and Fan Compartment

Item	Part No.	Qty.	Description
1	93182	1	FILTER ACCESS DOOR ASSEMBLY
2	41043	1	FILTER, BAFFLE, GILES, DOUBLE, 16HX20W
3	93302	1	FILTER, EAC ASSY, 20-IN, HANDLE & PLATE
4	31964	1	CHARCOAL FILTER, ASSY, 20 X 12-3/8
5	93296	1	BLOWER ASSEMBLY, GVH HOOD
6	93114	1	COVER, FIRE DAMPER, GVH HOOD
7*	41115	1	DAMPER, FIRE, 10 X 10, SHALLOW
8	21157	1	SWITCH, LIMIT, 15A, 250V
9	24209	1	L.E.D. CLUSTER, EAC FILTER
10	20399	1	INDICATOR LIGHT, AMBER, 250V, 0.5W
11	20398	1	INDICATOR LIGHT, GREEN, 250V, 0.5W
12	20402	2	INDICATOR LIGHT, RED, 250V, 0.5W
13	21190	1	SWITCH, ROCKER, D.P.S.T. 250V, 10A
14+	23173	1	SWITCH, PUSH-BUTTON, MOMENTARY
15	42827	1	DOOR LATCH (COMES WITH STRIKE)
16	41122	1	OUTER DOOR GASKET
17	41116	2	GASKET, EAC & CHARCOAL FILTER
18	41116	1	GASKET, BAFFLE FILTER

\* Not shown  
 + ILS Model Only

7-04. Under-Hood Components

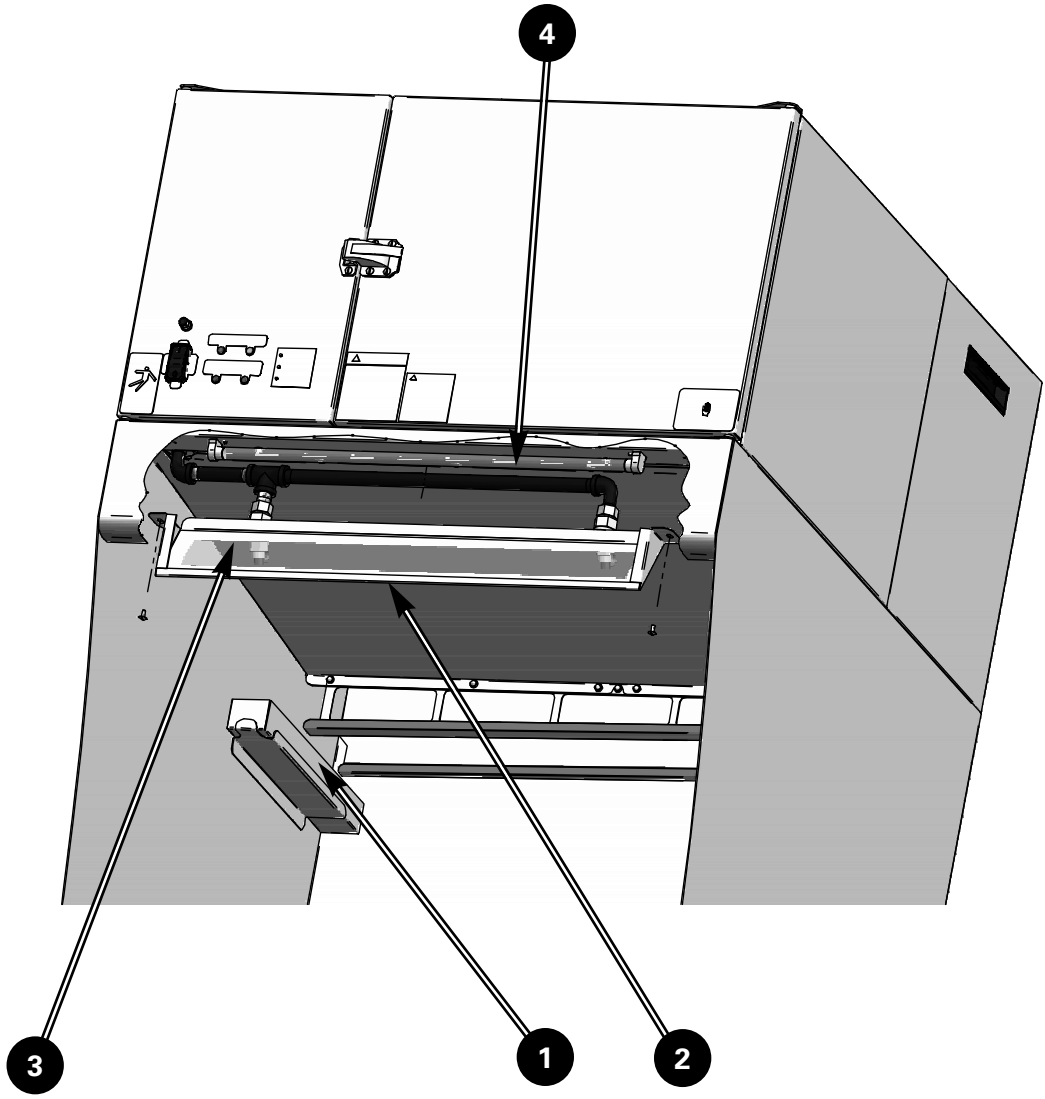



# Parts List

Model: **GVH-C, GVH-F**



## 7-04. Parts List for Under-Hood Components

Item	Part No.	Qty.	Description
1	93131	1	GREASE DRIP CUP
2	93987	1	LIGHT COVER FRAME
3	41113	1	GLASS, LIGHT COVER
4	20616	1	BULB, FLUORESCENT ,T5, 14W, 22" COOL



**Notes:**





**Giles Enterprises, Inc.**

2750 Gunter Park Drive West • Montgomery, Al 36109 USA

Phone 334.272.1457 • Toll Free 800.554.4537 (USA & Canada Only) • FAX 334.239.4117 • [www.gfse.com](http://www.gfse.com)

Form No. 65877 (Release date: 04/12) (Rev. A)