

# Operation Manual & Parts List

---

---

# Glastender®

A Family Company Manufacturing In The USA Since 1969

**LETTUCE CRISPER\* - LC**

**COUNTERTOP MERCHANDISER\* - CM24**

**WALL-MOUNT REFRIGERATOR\* - WMR24S-L, WMR24S-R,  
WMR24X-L, WMR24X-R**

---

---

**\*This manual is specific to Lettuce Crispers, Countertop Merchandisers, and Wall-Mount Refrigerators manufactured after SN 134171318X and prior to SN 290188989 and dated March 15, 2017 to June 16, 2019**



LC



CM24XX-RR



WMR24S-R

---

Glastender, Inc. · 5400 North Michigan Road · Saginaw, MI · 48604-9780  
800.748.0423 · 989.752.4275 · Fax 989.752.4444 · [www.glastender.com](http://www.glastender.com)



# INDEX

<b><u>Topic</u></b>	<b><u>Page</u></b>
Utility Requirements and Connections.....	2
Uncrating and Start-up Instructions.....	2
Mounting Instructions.....	3
Cleaning Instructions.....	4
Digital Controller Operation.....	5
Electrical and Refrigeration Specifications.....	6
Electrical Diagram.....	6
Replacement Parts.....	7-8
Electrical Components.....	8
Condenser and Related Parts.....	9-10
Terms and Conditions.....	11
Warranty.....	12

**IMPORTANT !!    Attention Service Companies    IMPORTANT !!**

Please review the important warranty information on page 10. If you believe a service call should be covered by the factory, please call the factory for authorization between 8AM and 5PM EST, Monday through Friday.

## INTRODUCTION

This manual describes the operation features of the Lettuce Crisper, Countertop Merchandiser, and Wall-Mount Refrigerator. Please review this information before attempting installation and operation. Long term, trouble-free operation will follow if good housekeeping and maintenance procedures are followed. Thank you for selecting Glastender, Inc. products.

## UTILITY REQUIREMENTS AND CONNECTIONS

**Electrical:** 120 Volt AC, 1 Phase, 60 Hz, 3.0 full load amps. A separate 15 amp circuit is required. A 10-foot grounded cord is included.

**Plumbing:** Automatic condensate evaporator. No drain connection required.

## UNCRATING AND START-UP INSTRUCTIONS

All models are shipped in one carton. These steps should be followed:

1. If legs are included, bolt them to the base with bolts provided. Follow installation guide on page 3.
2. For lettuce crisper and wall-mount refrigerator mounting instructions, see page 3.
3. Position unit. It must be level and plumb.
4. Plug into 120 volt AC outlet.
5. Your Glastender equipment is now ready for use.

# MOUNTING INSTRUCTIONS

## LEG MOUNTING INSTRUCTIONS:

NOTE: Mounting instruction applies to the lettuce crisper, countertop merchandiser, and wall-mount refrigerator.

NOTE: 8" of air space is required above unit to allow for air flow out. WARNING: Compressor failure due to restriction or blockage of air flow will void warranty.

1. Locate the unit on countertop in final position.
2. Level the unit (front to back and side to side).
3. Mark the countertop through the holes in the flanged foot of the leg.
4. Drill out the marked locations and secure the unit to the countertop using fasteners.

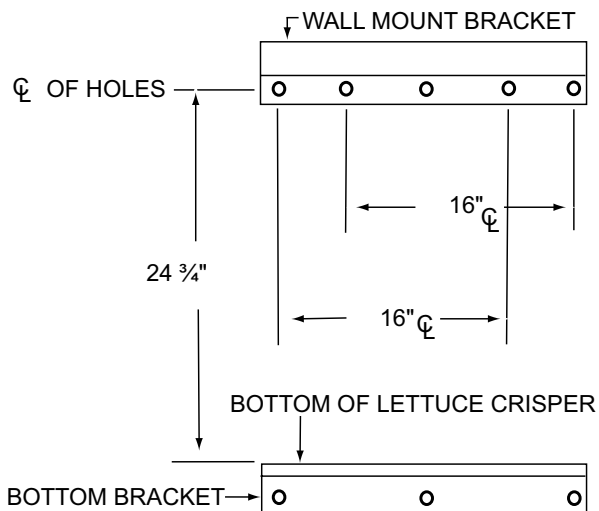

## WALL MOUNTING INSTRUCTIONS:

NOTE: Mounting instruction applies to both the lettuce crisper and wall-mount refrigerator. Lettuce crisper shown in illustration.

NOTE: 8" of air space is required above unit to allow for air flow out. WARNING: Compressor failure due to restriction or blockage of air flow will void warranty.

1. Mark a level line at the bottom of the lettuce crisper / wall-mount refrigerator.
2. From this line measure up 24 $\frac{3}{4}$ " and mark another level line.
3. On this line drill holes to match the holes in the wall mount bracket.
4. Install wall mount bracket.
5. Attach lettuce crisper / wall-mount refrigerator.
6. If lettuce crisper / wall-mount refrigerator is not on an existing shelf, secure with bottom bracket.

NOTE: At least two (2) of the mounting holes in the bracket should line up with studs in the wall for safe, secure mounting.

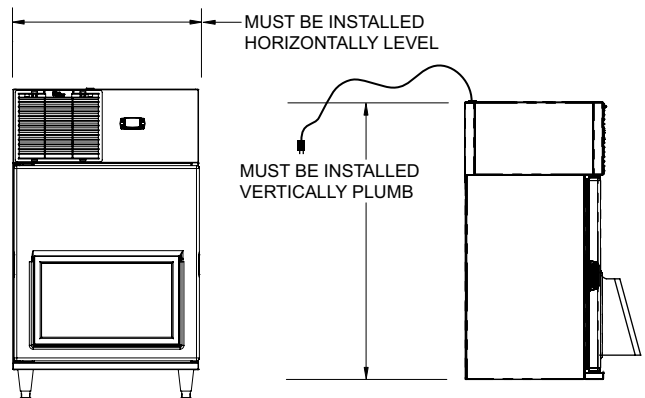
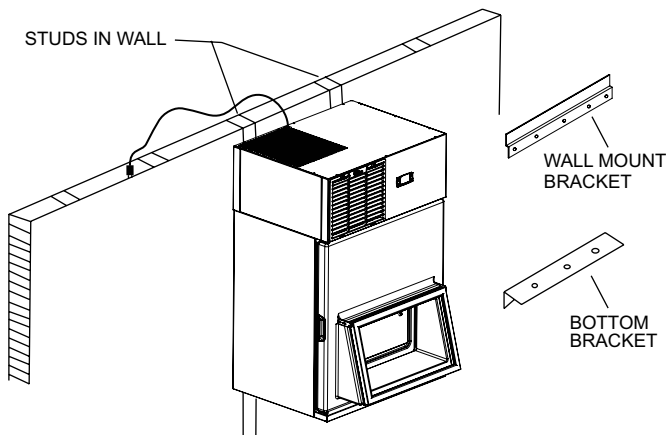

# CLEANING INSTRUCTIONS

**ESTIMATED CLEANING TIME:** 5 to 10 minutes per unit daily, 20 minutes weekly.

**FREQUENCY:** Daily cleaning of exterior & door gaskets. Weekly cleaning of interior.

**PROCEDURE:**

1. A non-chlorine based cleaner or mild detergent and warm water applied with a soft cloth or sponge to all contact surfaces.
2. Immediately rinse off cleaning agent(s), using clean warm water, clean soft cloth or sponge.
3. Dry with a soft clean cloth, removing standing water as soon as possible.
4. A more thorough cleaning of the interior should be done weekly (more frequently as necessary).
5. The condensing unit air filter (front top left) should be removed and thoroughly rinsed in hot clean water at least once per quarter.

**NOTES:**

1. Never use hydrochloric acid, wire brushes, steel wool, scrapers, or chlorine based cleaners on stainless steel surfaces, since they will break down the passivity layer and allow corrosion to occur.
2. On stainless steel surfaces, you may use a soft bristle brush or Scotch-Brite® pad for more stubborn stains. Always scrub with the direction of the grain. Follow with a thorough cleaning as described above.
3. Deposits from food preparation must be properly removed. Even hard water deposits will rust stainless steel, if not removed.
4. Door gaskets are most often overlooked when cleaning. Failure to clean them regularly will lead to premature failure, since alcohol and moisture build-up breaks down the gasket material.

# DIGITAL CONTROLLER OPERATION

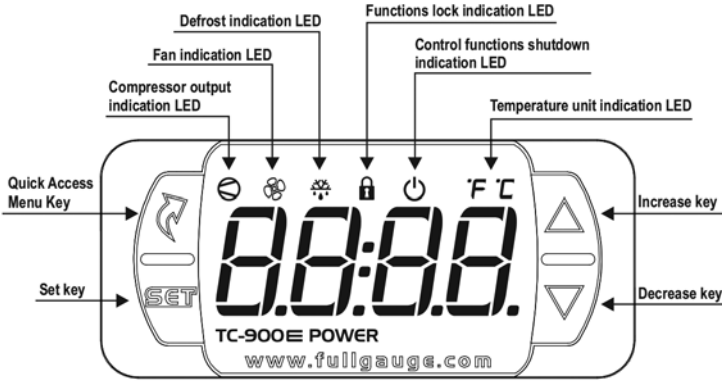

The operating temperature range is preset at the factory according to the table below and can be adjusted up or down within the limits shown.

## Setting the desired temperature-

To access the setpoints setup menu, press Set for 2 seconds. The message *SP* will appear on the display followed by the normal setpoint set value. Use the Increase key or Decrease key to modify the value and confirm by pressing Set. Immediately, the message *SP-E* appears indicating the setting of the economic setpoint. Again, use the Increase key or Decrease key to modify the value and confirm by pressing Set. Finally, the ---- indication signals the set up completion. The setpoints can also be adjusted individually in the quick access menu.

	Factory Settings		Range of Adjustment	
	Set Point	Operating Range†	Minimum Set Point	Maximum Set Point
LC, CM, WMR - Standard Cooler Setting	34° F	34° F to 39° F	33° F	65° F
CM, WMR - White Wine Cooler Setting	50° F	50° F to 55° F	33° F	65° F
CM, WMR - Red Wine Cooler Setting	60° F	60° F to 65° F	33° F	65° F

† Adjusting the factory set point will also adjust the operating range by the same amount

The lettuce crisper, countertop merchandiser, and wall-mount refrigerator are programmed to automatically defrost four times daily for approximately twenty minutes. During defrost, the fan inside the cooler will remain on and the refrigeration system will turn off. The defrost process can be activated/deactivated manually in the quick access menu through the *dEFr* or pressing the Increase key for 4 seconds. Activation or deactivation will be indicated by the messages *dEFr On* or *dEFr OFF* respectively.

The thermostat controller has an “OFF” function. The shutdown of the control functions allows the controller to operate only as a temperature indicator, keeping the control outputs and alarms off. The use of this feature is enabled or disabled by the shutdown function of the control functions. When enabled, the control functions and alarms are switched off *Ctrl OFF* or on *Ctrl On* in the quick access menu through the *Ctrl* option. When the control functions are off, the message *OFF* is displayed alternating with the temperature and other messages. Also is possible turn on/turn off the control functions by pressing the Increase key for 5 seconds.

**Models LC, CM24, and WMR24** - The thermostat control probe wire may become disconnected when the compressor compartment cover and/or grill are removed. This will result in thermostat *Err 1* or *Err 3* code. Service calls to reconnect the probe wiring are not covered by factory warranty.

SIGNALS	
<span style="border: 1px solid black; padding: 2px;">Err 1</span>	Ambient sensor disconnected or out of range.
<span style="border: 1px solid black; padding: 2px;">Err 3</span>	Sensor 3 disconnected or out of range.
<span style="border: 1px solid black; padding: 2px;">ECO</span>	Operation with economic setpoint.
<span style="border: 1px solid black; padding: 2px;">Aeth</span>	High ambient temperature alarm (sensor1).
<span style="border: 1px solid black; padding: 2px;">AELo</span>	Low ambient temperature alarm (sensor1).
<span style="border: 1px solid black; padding: 2px;">AC1</span>	High temperature in condenser alarm (level 1). If this signal occurs, condenser may need cleaning.
<span style="border: 1px solid black; padding: 2px;">AC2</span>	High temperature in condenser alarm (level 2). If this signal occurs, condenser may need cleaning.
<span style="border: 1px solid black; padding: 2px;">ALrC</span>	Compressor reached the maximum time on without reaching the SP.
<span style="border: 1px solid black; padding: 2px;">OFF</span>	Control routines off.
<span style="border: 1px solid black; padding: 2px;"> </span>	It indicates that the temperature for end of defrost has not been reached.
<span style="border: 1px solid black; padding: 2px;">ECAL</span>	Please contact Full Gauge Controls.
<span style="border: 1px solid black; padding: 2px;">PPPP</span>	Reconfigure the values of the functions.

# ELECTRICAL AND REFRIGERATION SPECIFICATIONS

The following electrical and refrigeration specifications apply:

<u>MODEL</u>	<u>ELECTRICAL</u>	<u>REFRIGERANT</u>		<u>DESIGN PRESSURE</u>	
		<u>TYPE</u>	<u>CHARGE</u>	<u>HIGH</u>	<u>LOW</u>
R134a LC	120V, 1 Ph., 60 Hz., 3.0 AMP	R134a	10 oz.	300	125

## ELECTRICAL DIAGRAM

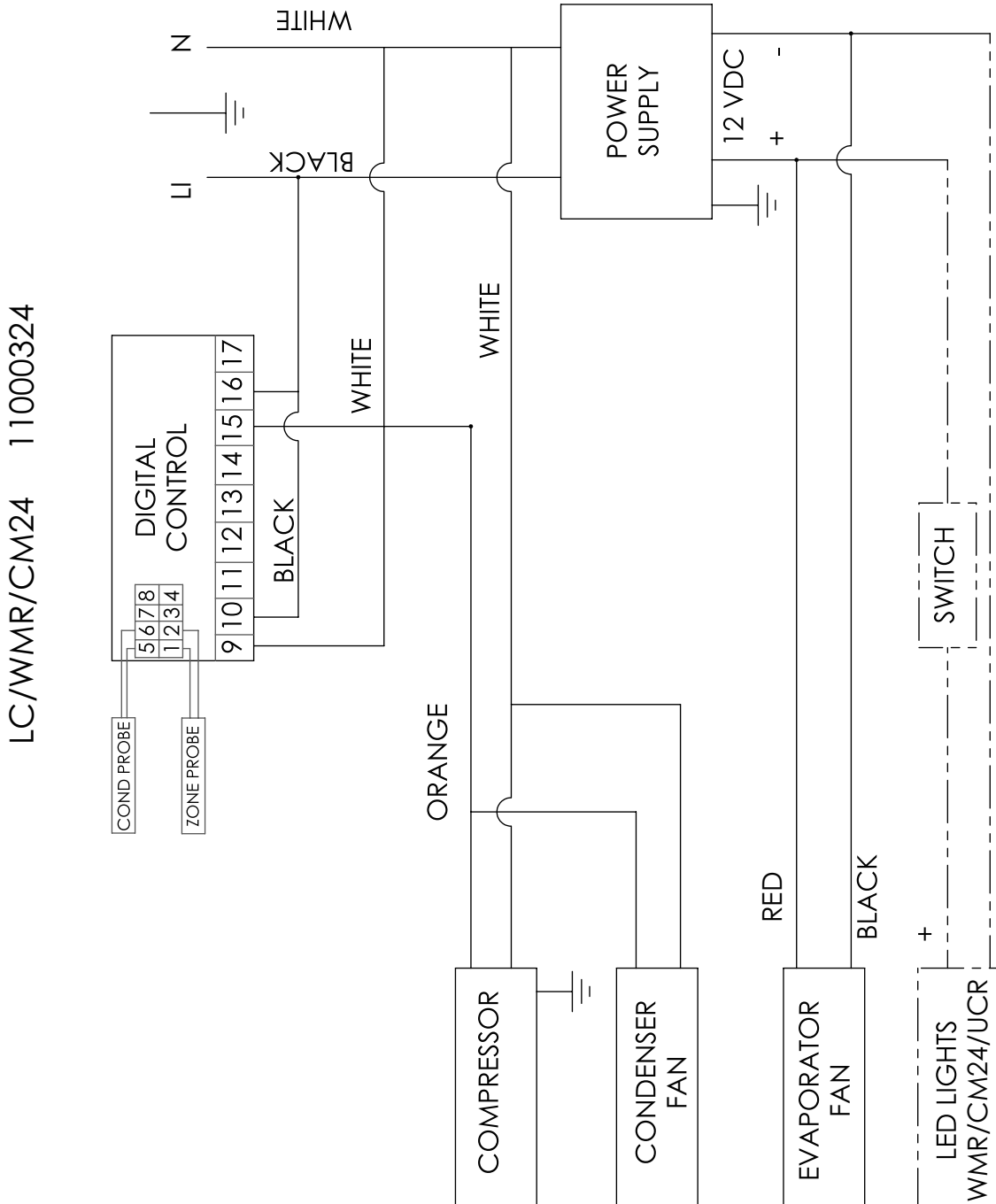

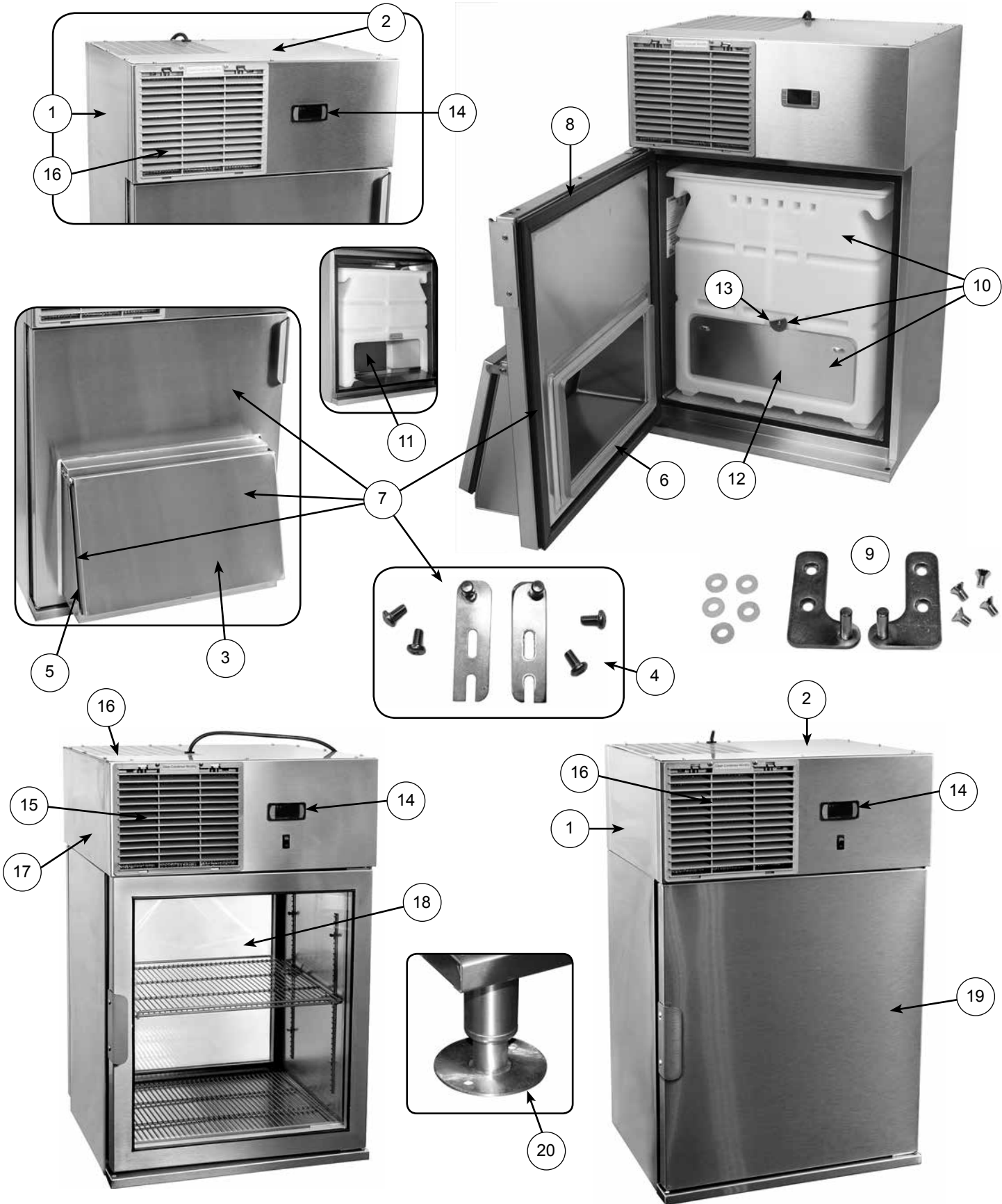

## REPLACEMENT PARTS

<u>PART NO.</u>	<u>DESCRIPTION</u>	<u>PRICE</u>
1. 11000349	Cover, left, access, LC, WMR	50.00
2. 11000227	Top cover, LC, WMR	150.00
3. 11000358	Door, LC, stainless flip	94.00
4. 11000359	Door hinge set, flip door, LC	25.00
5. 11000195	Gasket, bin door, LC, 18-13/16" x 11-7/16"	25.00
6. 11000070	Chute gasket, 5 feet, LC	21.00
7. 11000372	Main door, LC, stainless, left, complete (includes 11000068, 11000070, 11000358, 11000359, and 11000361) - DISCONTINUED - ORDER 11000379	
11000373	Main door, LC, stainless, right, complete (includes 11000068, 11000070, 11000358, 11000359, and 11000362) - DISCONTINUED - ORDER 11000379	
11000379	Door, LC, stainless, complete (includes flip lid and gaskets)	418.00
8. 11000068	Gasket, main door, black, 23-1/4" x 25" OD, LC, CM, WMR	42.00
9. 11000357	Door hinge set, main door, interchangeable for left and right swing, LC	35.00
10. LC-BIN	Plastic lettuce bin with stainless steel bin door, LC (includes 11000106, 11000092, and 11000095)	207.00
11. 11000108	Bin divider, stainless steel, LC-BDIV, LC	78.00
12. 11000092	Bin door, stainless steel, LC	36.00
13. 11000095	Bin door latch, LC	23.00
14. 06011056	Thermostat, LED, with probes, preset to standard temp range 34F-40F	120.00
15. 06001361	Grille, gray plastic	25.00
16. 11000235	Cover, top, CM	150.00
17. 11000350	Cover, access, left, CM	40.00
06001570	Cord, elastic, black, 28" long, looped to 14" w/clip for condenser filter, CM, WMR	1.00
18. 11000387	Door, glass, stainless, CM, WMR (includes handle)	648.00
19. 11000386	Door, stainless, CM, WMR (includes handle)	358.00
11000076	Hinge set, door, CM, WMR	25.00
11000306	LED lighting assembly, LC, CM, WMR	77.00
11000320	Shelf assembly, CM (includes shelf clips)	115.00
11000321	Shelf assembly, WMR (includes shelf clips)	90.00
11000109	Filter material, 8" x 10-1/4"	8.00
20. LCLS	Leg, 4", set of four, flanged, flat mounting holes	175.00

## ELECTRICAL COMPONENTS

<u>PART NO.</u>	<u>DESCRIPTION</u>	<u>PRICE</u>
06006121	Replacement powercord assembly (includes 06001572, 06009527)	\$40.00

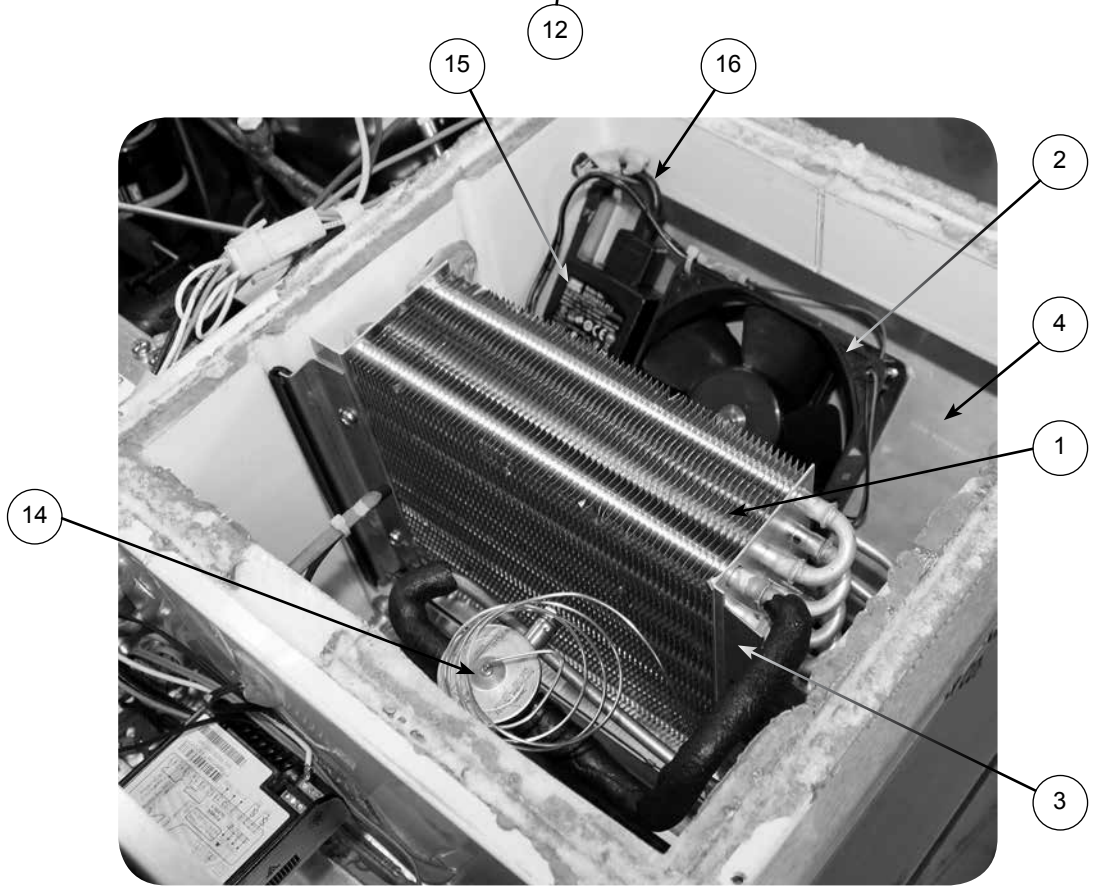
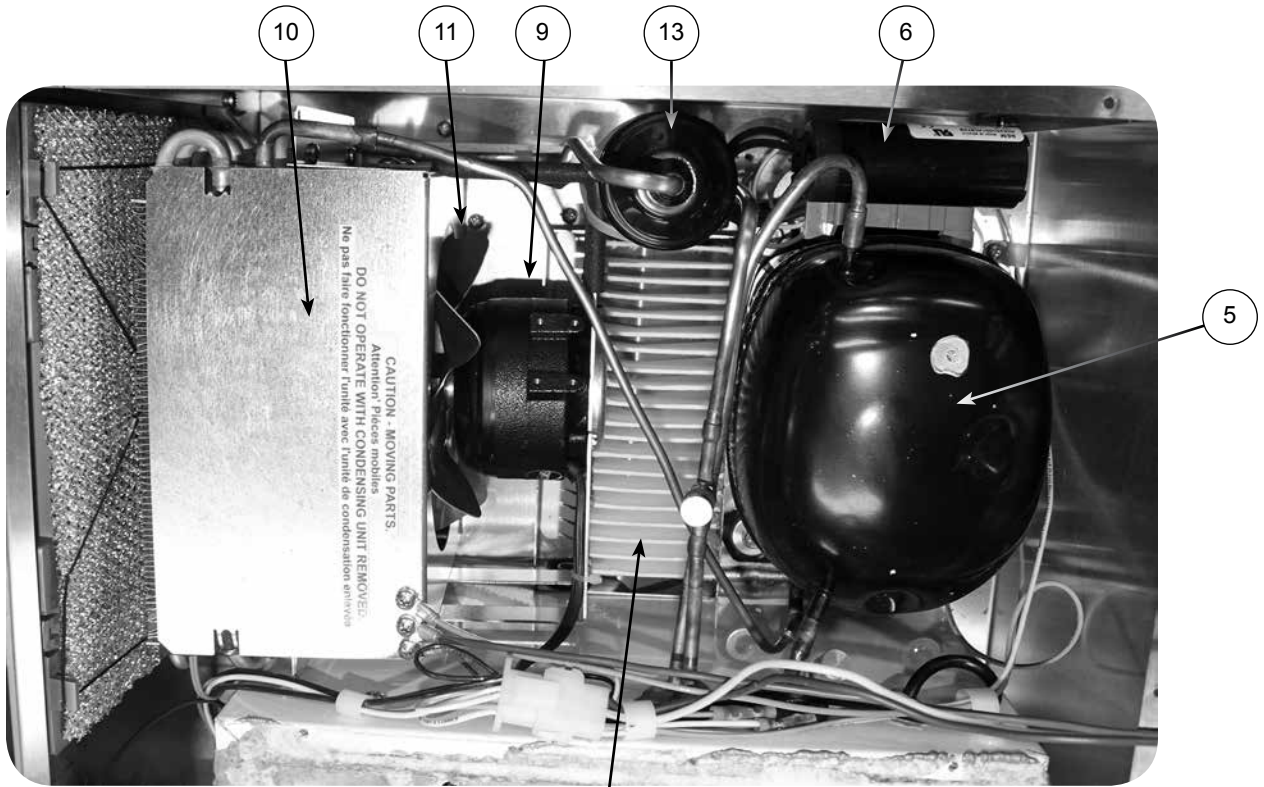

## CONDENSER AND RELATED PARTS

	<u>PART NO.</u>	<u>DESCRIPTION</u>	<u>PRICE</u>
1.	11000080	Coil, condenser	\$225.00
	11000079	Coil, evaporator	215.00
2.	06010024	Fan, axial, 12VDC	60.00
3.	11000339	Bracket, evaporator coil (set of 2)	11.00
4.	11000338	Evaporator fan shroud	20.00
5.	06008990	1/8 HP compressor, R134a	390.00
6.	06009280	Start capacitor, compressor	21.00
7.	06009279	Relay, compressor	15.00
8.	06009289	Overload protector, compressor	15.00
9.	06001449	Condenser fan motor	100.00
10.	11000078	Condenser fan shroud	20.00
11.	06010027	Fan blade, 6" diameter	10.00
12.	11000102	Wicking material (20 pieces 2-1/2" x 3")	24.00
	11000165	Evaporator drain pan	20.00
	11000200	Condenser drain pan replacement kit	30.00
13.	06010023	Filter dryer, receiver, combo	40.00
14.	06010046	Expansion valve, R134a, TUB, 0 orifice	110.00
15.	06006109	Power supply, 12V (Evaporator fan and LED lighting)	60.00
16.	06006607	Cord, 12V power supply	10.00

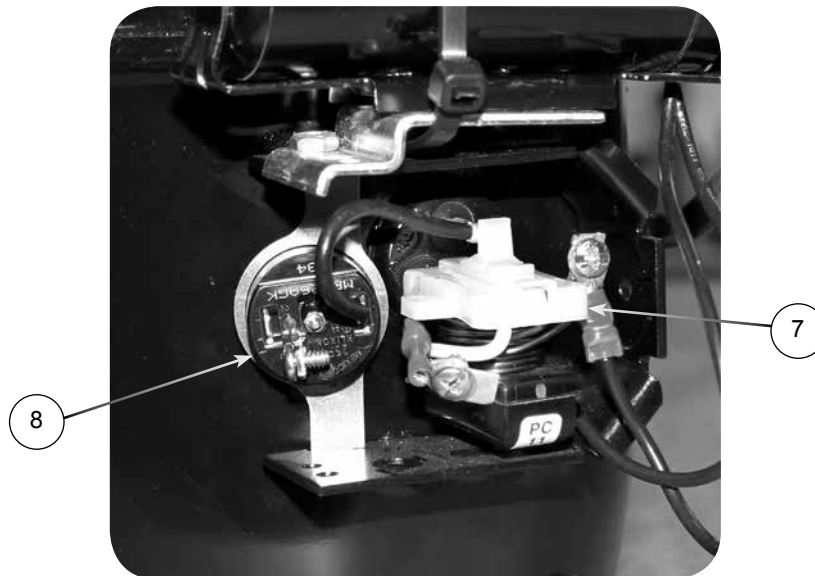

# TERMS AND CONDITIONS

**PRICES:**

All prices are LIST. Applicable taxes will be added.

**QUOTATIONS:**

Unless otherwise stated, quotations are effective for 30 days only.

**ACCEPTANCE:**

All orders are subject to acceptance by Glastender, Inc.'s headquarters in Saginaw, Michigan. Possession of the Product Directory and Price List is not an offer to sell.

**SHIPMENTS:**

F.O.B. factory in Saginaw, Michigan. Freight terms are Third Party or Collect if shipped directly to you. Prepay and Add to Invoice freight terms are available upon request. The approximate shipping weights of all products are listed with the prices. Partial shipments will be made unless otherwise specified by the customer. Surface freight classifications are:

- GT-24/GT-30/GW24 Glasswashers - Class 175
- GT-18 Glasswashers - Class 250
- All Underbar Equipment - Class 175
- Bar Die Orders – Class 250
- Portable Bars - Class 175
- Remote refrigerators (i.e., no compressor) or dry storage back bar equipment - Class 175
- Self-contained refrigeration equipment - Class 150
- Ice Display Units (IDU and GDU) - Class 85
- Lighted Liquor Displays - Class 85
- Beer line chillers and beer towers (beverage dispensing equipment) - Class 92.5
- Bottle Disintegration System - Class 150
- Ice Cream Freezers - Class 77.5

All small items are evaluated to see the most cost effective means for shipment. Many small items ship via UPS or FedEx; however, when dimensional weight is excessive, LTL carriers are the most cost effective choice. Spare parts orders received before 1:00 PM EST can usually be shipped the same day.

The order department is happy to assist with routing or shipping questions.

**PAYMENT TERMS:**

Cash should be included with all orders unless credit terms have been arranged. To establish credit, banking and trade references are required. A convenient credit application is available upon request. Payment via credit card is not our normal means of receiving payment. Visa and MasterCard will be accepted, but must be charged at the time of shipment. In addition, a payment via credit card for orders totaling more than \$500 will incur a 3% convenience fee on the total transaction amount.

**DELIVERY:**

The majority of equipment is manufactured to order and typically ships within three to six weeks after complete order information is received by the factory. In-stock equipment typically ships within two to three days of the factory receiving complete order information.

**RETURNS:**

Items specified as "Manufactured to Order" are NOT returnable.

A Return Authorization number must be issued by the factory in advance for any items that are returnable. The number MUST be noted on the outside of the returned package. Returns must be received within 90 days of the issue date. Shipping charges must be prepaid. A minimum 20% restocking charge will be applied to all authorized returns if received in new, unused condition in the original packaging.

The above conditions apply to spare part returns, except spare part returns must be received within 30 days of original shipment for electronic or electrical parts or within 90 days for all other parts.

**LOSS OR DAMAGE:**

For customer routed shipments, Glastender, Inc. is not responsible for any loss, damage, or delay of merchandise during shipment. Such transit claims must be filed with the carrier. Merchandise must be examined on arrival. If shortages occur, Glastender, Inc. must be notified in writing within five (5) days of delivery to honor any shortage claim. Glastender will assume responsibility for freight claims on Prepay and Add shipments but the customer must inspect freight and note any damage upon receipt. Failure to do so may result in losses at the customer's expense.

**CUSTOM ORDERS:**

Custom orders must be paid in advance and are not subject to cancellation.

**LAMINATES:**

Some products include common, readily available plastic laminates of the customer's selection. There may be an additional charge if uncommon varieties are ordered.

12/14/17

# WARRANTY STATEMENT

## APPLICABLE TO ALL PRODUCTS SOLD WITHIN THE UNITED STATES AND CANADA

Glastender, Inc. warrants all products to be free of defects in material and workmanship. One-year labor and parts warranty applies to all glasswashers, self-contained refrigeration models, and BDS model bottle disintegration units. In established areas, a start up is included with GT-24 and GT-30 model glasswashers. Warranty is effective for one year from the date of installation or up to 18 months from date of factory shipment, whichever occurs sooner. Glastender, Inc. will replace any part or assembly found defective under normal use and service.

For warranty labor claims beyond 15 months from the date of factory shipment, proof of date of installation or occupancy must be provided. Authorization for labor must be obtained from Glastender within the warranty period and prior to the service being performed.

Labor warranty applies to the United States and Canada only.

Remote refrigeration models and beer line chillers include a one-year parts warranty only. There is no labor warranty on these products.

Field replacement parts not covered under the original warranty include a 90-day part warranty from the date of installation.

**FOUR YEAR ADDITIONAL COMPRESSOR WARRANTY:** Glastender will warrant to the original user the compressor for all self-contained refrigeration models for an additional four years following the regular one-year warranty period. This plan applies to the compressor only.

A completed warranty claim form **MUST** accompany all returned defective parts or assemblies. Upon request, a defective part or assembly must be returned to Glastender, Inc., Saginaw, Michigan, with all transportation and delivery charges prepaid. Warranty repairs or replacements will be shipped FOB factory in Saginaw, Michigan. Reimbursement for applicable freight charges covers ground service only.

Glastender provides in-warranty repairs during a service company's regular working days and hours. There is no provision for payment of a premium rate during "overtime" hours. When warranty service is requested during other than normal working hours, the end user will be charged the premium portion of the overtime rate.

The warranty covers substantiated travel expenses for up to 2 hours / 100 miles round trip up to a maximum of \$150. Any additional costs due to installations that require extra work, time, or travel to gain access for service are the sole responsibility of the equipment purchaser. Any exceptions to these travel and access limitations must be pre-approved by a factory representative.

The warranty does not cover door gaskets, chemical tubing, pump squeeze tubing, and/or any equipment subjected to accidents, freight damage, alterations from the original design, improper power and/or plumbing hookups, improper chemical use, general misuse, or lack of routine required maintenance as determined by Glastender, Inc. Installation, normal control adjustments, general maintenance, correcting an installation error, or service calls that reveal the unit is functioning normally will not be reimbursed under warranty.

Condenser coils on self-contained refrigeration products must be cleaned regularly. Failure to provide adequate air flow to a refrigeration unit will void the warranty.

Glastender shall not be liable for loss of use, revenue, or profit, or for any other indirect, incidental, special, or consequential damage including, but not limited to, product spoilage or loss.

This warranty is conditioned upon Glastender receiving notice of any defect subject to this warranty within sixty (60) days of its discovery by the end user or dealer. All products are warranted only for the initial place of installation. Removal of a product automatically terminates this warranty.

Glastender, Inc. • 5400 North Michigan Road • Saginaw, MI • 48604-9780  
800.748.0423 • 989.752.4275 • Fax 989.752.4444 • www.glastender.com

### SECOND YEAR EXTENDED PARTS & LABOR WARRANTY:

Glastender's one-year parts and labor warranty on self-contained refrigeration units, excluding beer line chillers, can be extended to two years with the purchase of a two year parts and labor warranty. Specify part number EWR2 (\$150 net price) when ordering.

EXPORT WARRANTY - One year parts only.

### EXCLUSION OF WARRANTIES

EXCEPT AS PROVIDED ABOVE, GLASTENDER MAKES NO WARRANTIES, EXPRESS OR IMPLIED, INCLUDING, BUT NOT LIMITED TO, ANY IMPLIED WARRANTY OF MERCHANTABILITY, FITNESS FOR A PARTICULAR PURPOSE OR NON-INFRINGEMENT.

### LIMITATION OF REMEDIES AND DAMAGES

If Buyer makes a valid and timely claim as outlined above, Glastender's liability and Buyer's remedies under this agreement will be limited solely to labor charges authorized and/or replacement or credit, at Glastender's option, with respect to Products returned at Buyer's expense within thirty (30) days after warranty repair. GLASTENDER'S LIABILITY WILL IN NO EVENT BE GREATER IN AMOUNT THAN THE PURCHASE PRICE OF THE RETURNED PRODUCTS. GLASTENDER WILL NOT BE LIABLE UNDER ANY CIRCUMSTANCE FOR CONSEQUENTIAL OR INCIDENTAL DAMAGES, INCLUDING, BUT NOT LIMITED TO, LABOR COSTS EXCEPT AS COVERED UNDER OUR WARRANTY, LOST PROFITS OR THE LOSS OF PERISHABLE PRODUCTS RESULTING FROM THE USE OF OR INABILITY TO USE OUR PRODUCTS OR FROM OUR PRODUCTS' INCORPORATION INTO OR BECOMING A COMPONENT OF ANY OTHER PRODUCT. NEITHER PARTY WILL HAVE ANY NEGLIGENCE OR OTHER TORT LIABILITY TO THE OTHER, OR TO ANY THIRD PARTY, ARISING FROM ANY BREACH OF THIS AGREEMENT.

### GOVERNING LAW - JURISDICTION

The terms and conditions of an order are to be governed and construed according to the laws of the State of Michigan, without regard to conflict of laws principles. Buyer hereby consents to the jurisdiction and venue of the courts located in Saginaw County, Michigan.

No representative, distributor, dealer, or any other person is authorized to modify this warranty. This warranty replaces all other written or verbal warranties.

NOTE: Glastender, Inc.'s policy of constant quality improvement means that prices, specifications, and policies are subject to change without notice. Questions regarding this warranty should be directed to Glastender's Warranty Administrator.

04-19-17

## **IMPORTANT!!**

### Attention Service Companies

Please review the important warranty information on this page. If you believe a service call should be covered by the factory, please call the factory for authorization between 8AM and 5PM EST, Monday through Friday.

**Glastender.**

OM-LC-CM-WMR-01