

Parts Catalogue

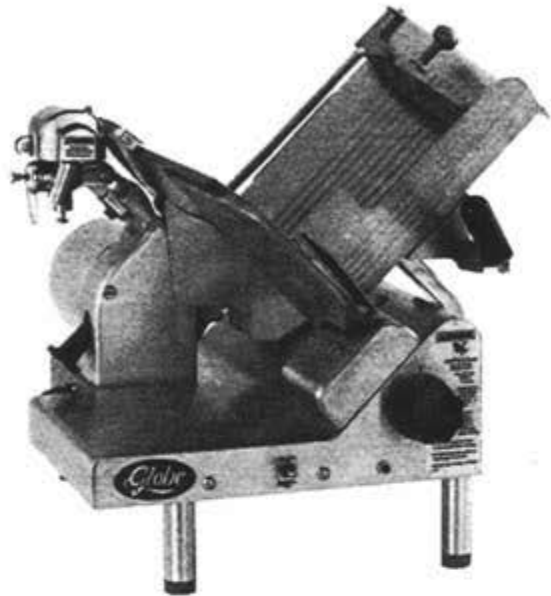
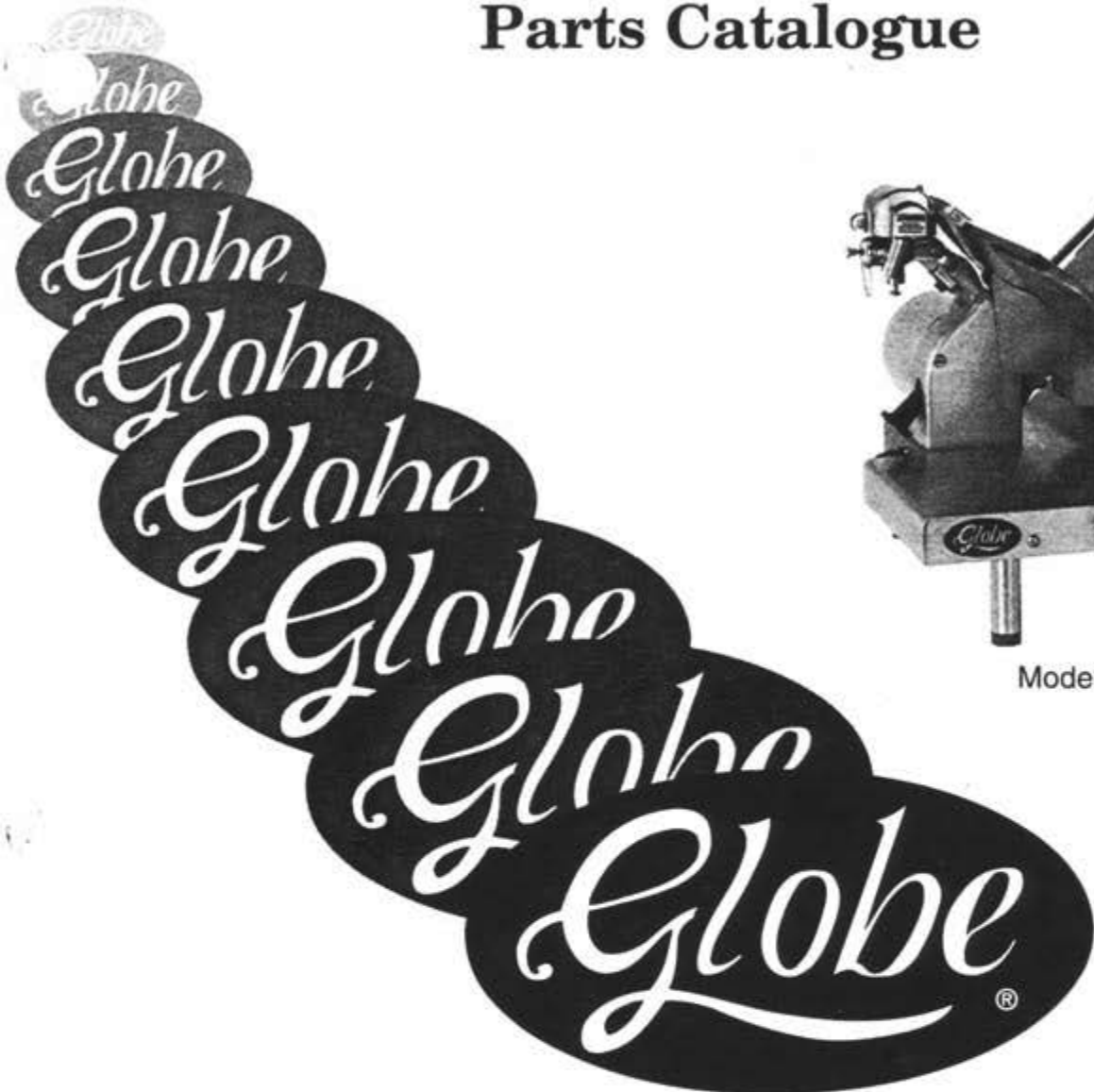

Model 2500

SLICING MACHINES

MODEL: 2500, 2850V & 2875V

7-1-2002

IMPORTANT!

TO EXPEDITE SHIPMENT OF PARTS, ALWAYS SPECIFY MODEL, REV,
PART NUMBER, AND SERIAL NUMBER OF SLICER.

GLOBE FOOD EQUIPMENT COMPANY

2268 N. Moraine Drive

Dayton, Ohio 45439

Parts Department

Toll Free 1-800-745-6238 • Fax (937) 290-0585

E-Mail: globeinfo@globeslicers.com

Website: www.globeslicers.com

TABLE OF CONTENTS

ASSEMBLIES	1
BASE	2
BASE SHROUD AND COMPONENTS	3
TABLE	4
SLIDE SYSTEM	5
TABLE ADJUSTMENT COMPONENTS	7
GEAR HOUSING AND KNIFE	9
MOTORS	11
KNIFE MOTOR HARDWARE	12
KNIFE PLATE	13
KNIFE COVER AND RIM GUARD	15
SHARPENER	17
STAINLESS STEEL CHUTE AND SUPPORT	19
END WEIGHTS	20
SLICE DEFLECTOR AND PIN	21
QUICK RELEASE AUTOMATIC CHAIN SLIDE	22
AUTOMATIC BASE APRON AND CHAIN GUARD	23
LIFT LEVER SYSTEM	24
AUTOMATIC CHUTE DRIVE SYSTEM	25
CHUTE MOTOR PLATFORMS AND HARDWARE	27
WIRING HARNESS AND COMPONENTS	28
ELECTRICAL COMPONENTS AND HARDWARE	29
VEGETABLE HOPPER ACCESSORY	31
CHUTE FENCES ACCESSORY	32
RECEIVING PAN AND LID ASSEMBLY WITH STAND	33
JUICE BOX ACCESSORY	34
TOOL LIST	35

ASSEMBLIES (ALL MODELS)

ASSEMBLY DESCRIPTION	PART NUMBER
Sharpener Assembly Without Cover	10-A-1
*Cover and Cover Hardware Sold Separately	
Stainless Steel Chute 12" Includes End Weight Without Prongs	102-AS-8
Stainless Steel Chute 12" Includes End Weight With Prongs	102-AS-9
Knife Cover Assembly	972-C-AS
Knife Plate Assembly - Fibre Gear	972-P-AS
Knife Plate Assembly - Bronze Gear	972-P-AS-1
Knife Plate Assembly - Nylon Gear	972-P-AS-2
Slide and Bushing Assembly	436-B-AS
64 Link Slide Drive Chain Assembly	766-2BAS
Table Assembly	826-AS
Gear Housing Assembly	969-AS
Stainless Steel End Weight Assembly Without Prongs	741-SS-AS
Stainless Steel End Weight Assembly With Prongs	741-SS-APC
Automatic Main Switch Assembly (Without Boot)	952-10
Automatic Chain Slide Assembly	916-AS
Table adjusting Gear Assembly	453-AS

ACCESSORIES



VEGETABLE HOPPER



JUICE BOX

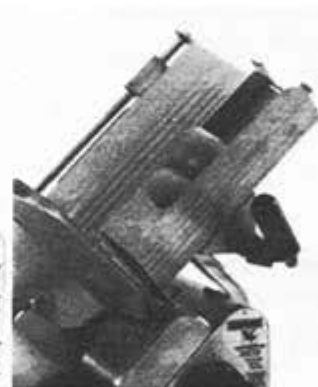

ADJUSTABLE STAINLESS
STEEL FOOD FENCES

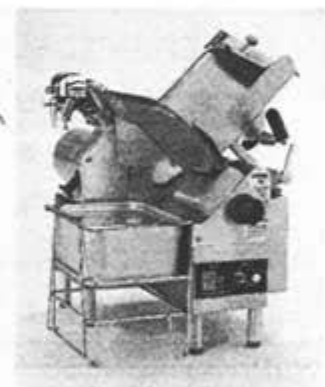

RECEIVING TRAY STAND,
PAN AND LID ASSEMBLY

DESCRIPTION	PART NUMBER
VEGETABLE HOPPER (CYLINDER CHUTE)	699-AS
JUICE BOX	676-AS
FENCE SHORT-HIGH 12" x 3" HIGH	940-FSH
FENCE SHORT-LOW 12" x 1 3/8" HIGH	940-FSL
FENCE LONG-HIGH 17" x 3" HIGH	940-FLH
FENCE LONG-LOW 17" x 1 3/8" HIGH	940-FLL
RECEIVING PAN, LID, STAND	958-AS
STAINLESS STEEL CHUTE 17" INCLUDES END WEIGHT WITH PRONGS	102-AS-10
ALUMINUM CHUTE 12" INCLUDES END WEIGHT WITHOUT PRONGS	102-AS-1
ALUMINUM CHUTE 12" INCLUDES END WEIGHT WITH PRONGS	102-AS-2

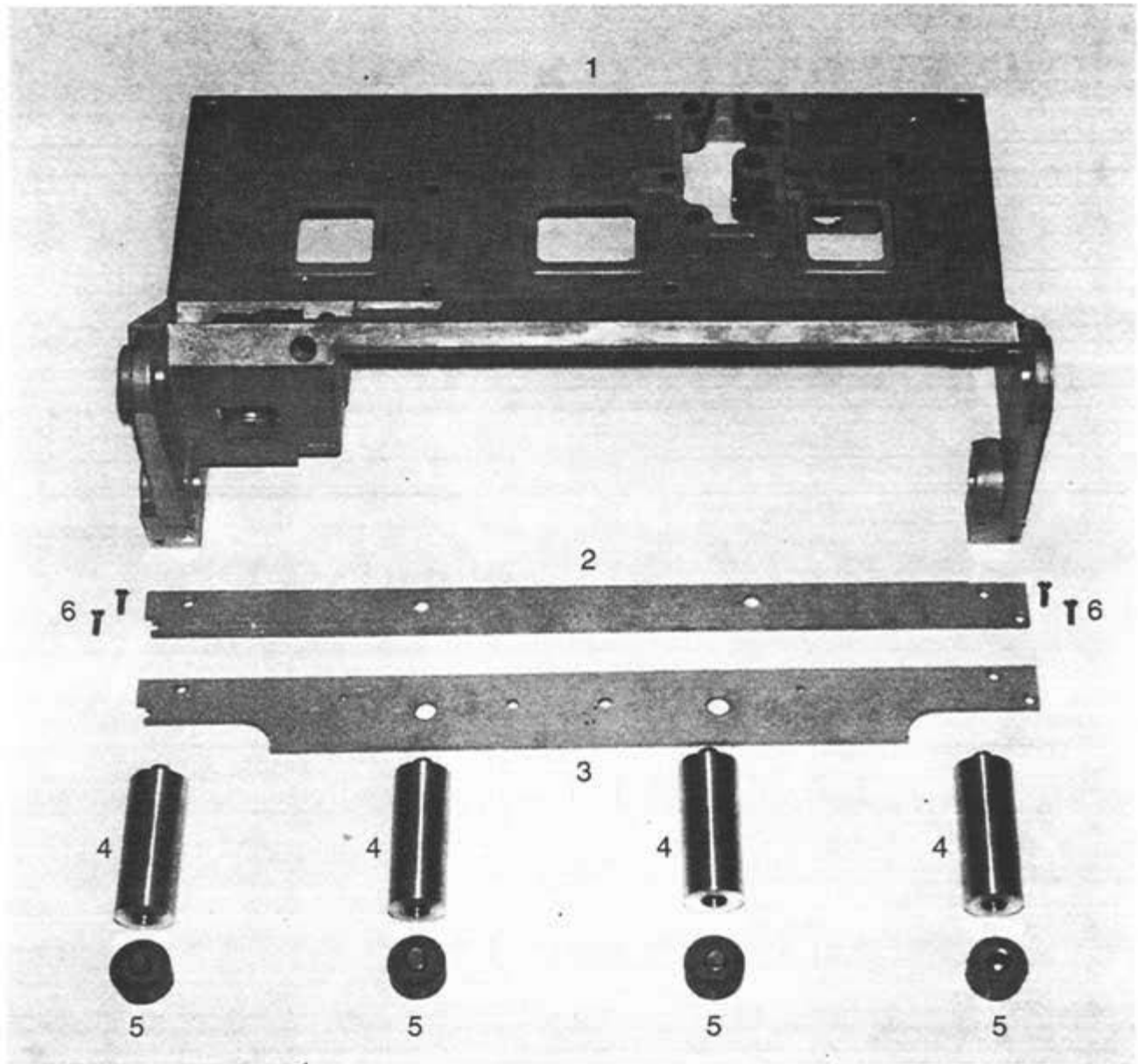

BASE

ITEM	DESCRIPTION	PART NUMBER	MODEL NUMBER					
			2500	2750	2875V	2850V	ALL	
1	BASE	850-DC	X	X	X			
	BASE	850-25					X	
2	BASE SUPPORT RIB	850-1	X					
3	SPROCKET STUD MOUNT	887		X	X	X		
4	BASE FOOT EXTENSION (4-5 REQ'D)	873	4				5	
5	BASE PAD RUBBER FOOT (4-5 REQ'D)	817	4	4	4	4	5	
6	SUPPORT RIB SCREW (4 REQ'D)	834-S						X

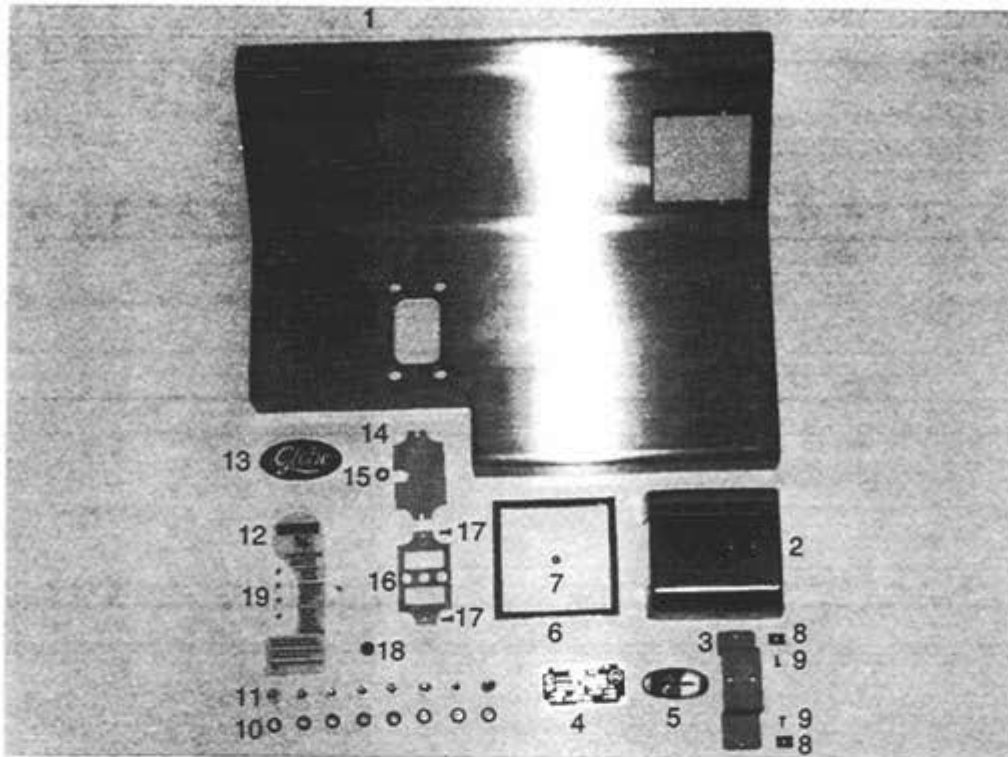

BASE SHROUD AND COMPONENTS

ITEM	DESCRIPTION	PART NUMBER	MODEL NUMBER			
			2500	2750	2875V	2850V ALL
1	BASE SHROUD	953	X			
	BASE SHROUD	960		X	X	
	BASE SHROUD	900				X
2	TABLE COVER	866				X
3	TABLE COVER BRACKET	867				X
4	DATA PLATE BLANK	885-1BLR				X
5	OIL DAILY DECAL	442-3				X
6	TABLE COVER GASKET	867-3A				X
7	OIL HOLE BUSHING	243-1				X
8	TABLE COVER BRACKET NUT (2 REQ'D)	867-2				X
9	TABLE COVER BRACKET SCREW (2 REQ'D)	867-1				X
10	BASE SHROUD NUT (8 REQ'D)	851-3FN				X
11	BASE SHROUD SCREW (8 REQ'D)	851-1				X
12	WARNING PLATE - ENGLISH	967-1				X
	WARNING PLATE - SPANISH	967-1S				X
13	GLOBE LOGO DECAL	871-2				X
14	BASE COVER PLATE	852				X
15	BASE COVER PLATE BUSHING	852-3				X
16	BASE COVER PLATE SUPPORT	852-2				X
17	BASE COVER PLATE SCREW (2 REQ'D)	852-1				X
18	BASE SHROUD PLUG BUTTON	851-5				X
19	WARNING PLATE DRIVE PIN (4 REQ'D)	8516P				X
NOT SHOWN	COVER SCREW (2 REQ'D)	866-1KH				X

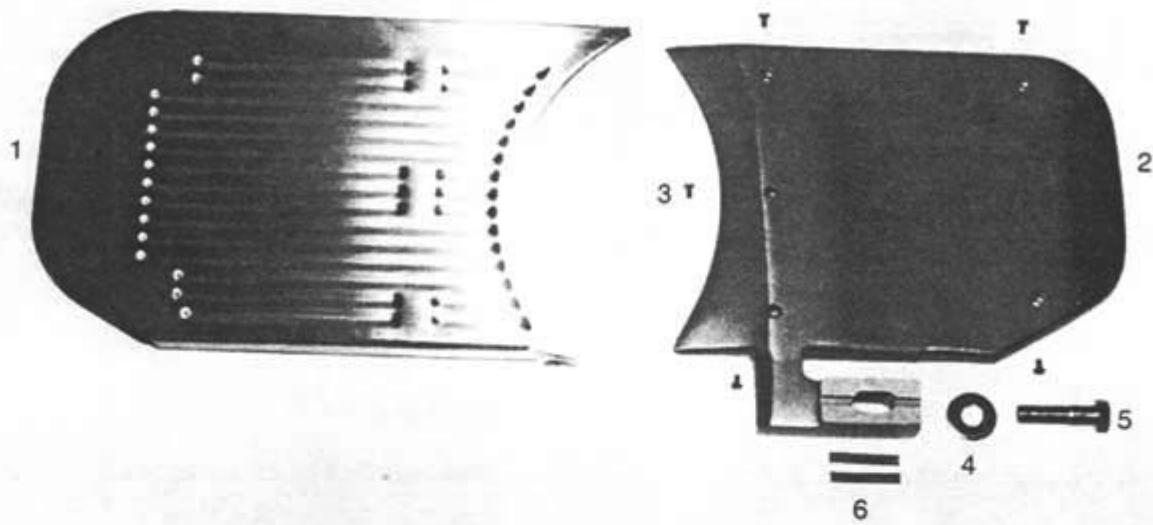

TABLE ALL MODELS

ITEM	DESCRIPTION	PART NUMBER
	TABLE ASSEMBLY	826-AS
1	● TABLE STAINLESS STEEL	826
2	● TABLE SUPPORT	862
3	● TABLE SCREW (5 REQ'D)	338
4	TABLE SCREW WASHER	756-2
5	TABLE SCREW	862-1
6	TABLE SHIMS	337-A

SLIDE SYSTEM

ITEM	DESCRIPTION	PART NUMBER	MODEL NUMBER				ALL
			2500	2750	2875V	2850V	
	SLIDE AND BUSHING ASSEMBLY	436-B-AS					X
	● SLIDE OIL TUBING	436-A					X
1	● SLIDE	436-B					X
2	● UPPER SLIDE ROD BUSHING (2 REQ'D)	436-7					X
3	● OIL FELT SPRING CLIP (2 REQ'D)	436-4					X
4	● BUSHING OIL FELT	170					X
5	● LOWER SLIDE ROD BUSHING	449					X
6	● BUSHING STUD NUT	228					X
7	● LOWER BUSHING STUD	241-B					X
8	UPPER SLIDE OIL FELT	436-3					X
9	SLIDE BAR - UPPER	857					X
10	SLIDE BAR - LOWER	858					X
11	UPPER SLIDE BAR CLIP	857-1					X
12	LOWER SLIDE BAR CLIP	858-1					X
13	SLIDE ROD WASHER (2 REQ'D)	859					X
14	SLIDE ROD SCREW (2 REQ'D)	859-1					X
15	SLIDE BUMPER	918	2	4	4	4	
16	UPPER SLIDE ROD BUMPER (2 REQ'D)	436-1U	X				
17	CHUTE RECEIVER	883-M	X				
18	CHUTE RECEIVER	883		X	X	X	
19	RECEIVER STUD NUT (2 REQ'D)	478-1					X
20	RECEIVER STUD LOCK WASHER (2 REQ'D)	245-A					X
21	CHUTE ADJUSTING SCREW	167-1					X
22	CHUTE ADJUSTING SET SCREW	168-1					X
NOT SHOWN	LUBRICATION OIL	519					X
NOT SHOWN	BUMPER SPRING (4 REQ'D)	919-1		X	X	X	

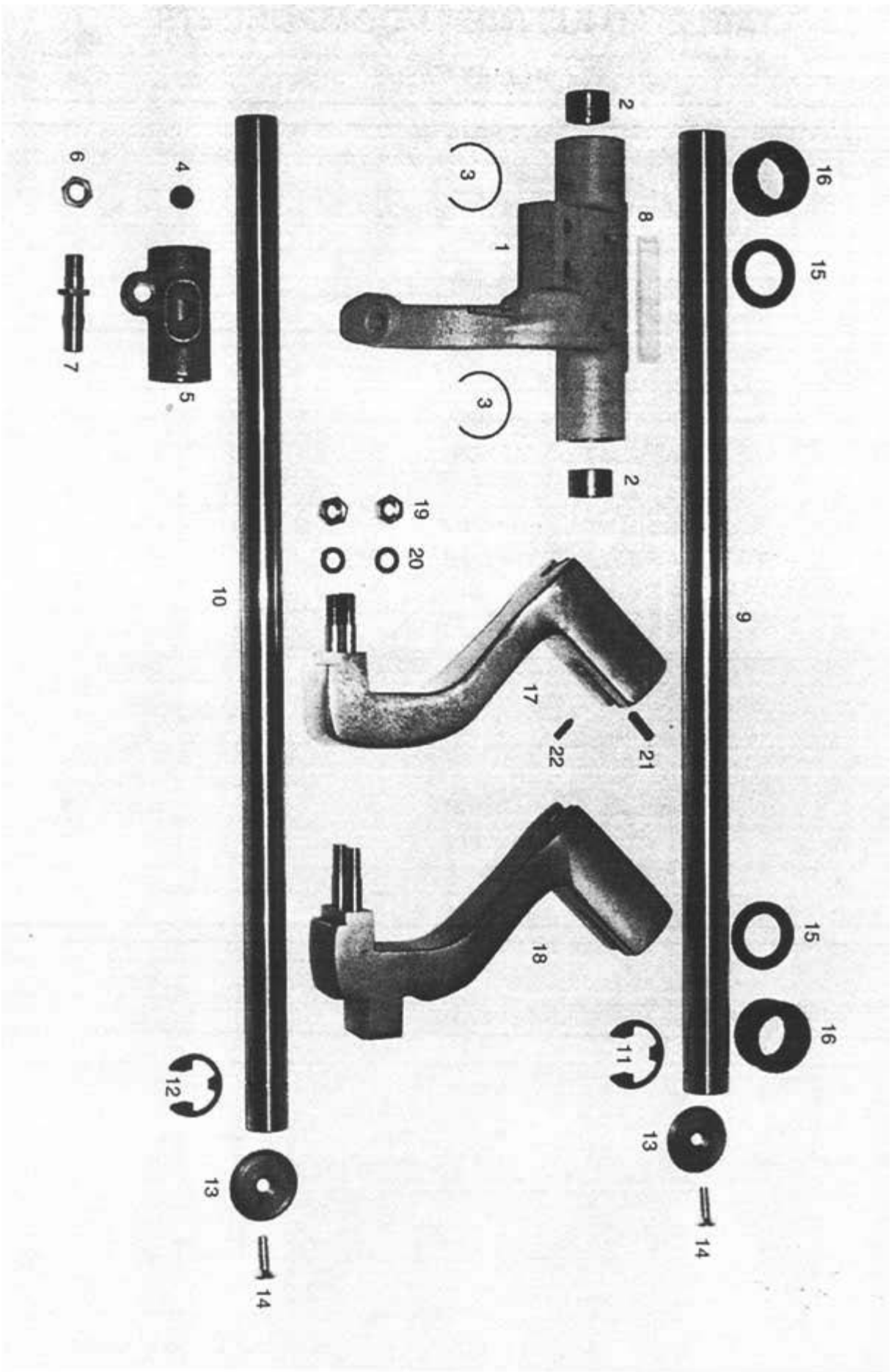
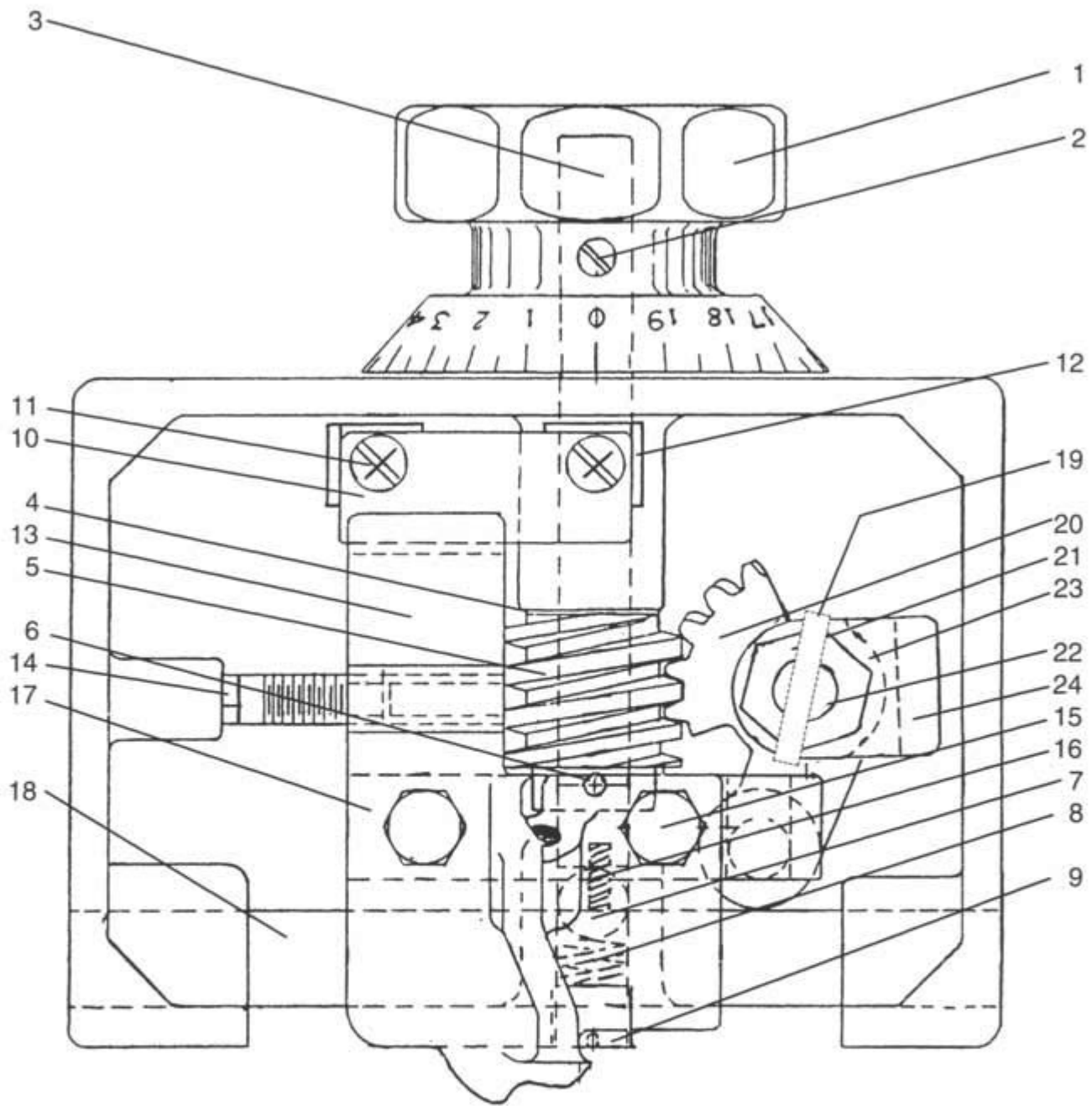

TABLE ADJUSTMENT COMPONENTS

ALL MODELS

ITEM	DESCRIPTION	PART NUMBER
1	TABLE ADJUSTMENT KNOB	407-1B
2	TABLE ADJUSTING KNOB SCREW (2 REQUIRED)	356-1
3	TABLE ADJUSTING KNOB SHAFT	864
4	TABLE ADJUSTING WORM WASHER	359
5	TABLE ADJUSTING WORM	358
6	TABLE ADJUSTING WORM PIN	360
7	TABLE ADJUSTING KNOB BALL	362
8	TABLE ADJUSTING KNOB SPRING	361
9	TABLE KNOB SHAFT THRUST SCREW	361-1
10	TABLE SLIDE GUIDE	349
11	TABLE SLIDE GUIDE SCREW (2 REQ'D)	350
12	TABLE SLIDE GUIDE SHIMS (ASSORTED SIZES)	349-A
13	TABLE SLIDE	863
14	TABLE SLIDE STOP SCREW	493-1
15	TABLE ADJUSTING CAM SCREW (2 REQ'D)	353-1
16	TABLE SLIDE SET SCREW	346
17	TABLE ADJUSTING CAM	865
18	TABLE SLIDE SHAFT	344
	TABLE ADJUSTING GEAR ASSEMBLY	453-AS
19	● TABLE ADJUSTING GEAR PIN	365
20	● TABLE ADJUSTING GEAR	453
21	● TABLE ADJUSTING GEAR BUSHING SCREW	335
22	● TABLE ADJUSTING GEAR SHAFT	364
23	● TABLE ADJUSTING GEAR SHIM (ASSORTED SIZES)	363-A
24	● TABLE ADJUSTING GEAR YOKE	334



GEAR HOUSING AND KNIFE

ALL MODELS

ITEM	DESCRIPTION	PART NUMBER
	GEAR HOUSING ASSEMBLY	969-AS
1	GEAR HOUSING	969
2	KNIFE, HOLLOW GROUND (CARBON)	963-HC
	KNIFE, HOLLOW GROUND (STAINLESS STEEL)	963-S
3	KNIFE GUARD STUD KNOB ASSEMBLY	879-AS
4	GEAR HOUSING SCREW (4 REQ'D)	369-1
5	GEAR LUBE 140W (QUART)	972-A
6	MOTOR SCREW 3 1/2"	969-1
7	INTERLOCK SWITCH PLUNGER	854-8
8	GEAR HOUSING FELT	370
9	MOTOR SCREW (SHORT) (2 REQ'D)	795-S
10	INTERLOCK SWITCH INSULATOR	854-4
11	INTERLOCK SWITCH BRACKET	854-5
12	INTERLOCK SWITCH SCREW WASHER (2 REQ'D)	854-7
13	INTERLOCK SWITCH BRACKET SCREW (2 REQ'D)	854-6
14	INTERLOCK SWITCH SCREW (2 REQ'D)	854-2
15	INTERLOCK SWITCH SCREW NUT (2 REQ'D)	854-3
16	KNIFE SCREWS (6 REQ'D)	747-15S
NOT SHOWN	INTERLOCK RETAINER STUD	879-5

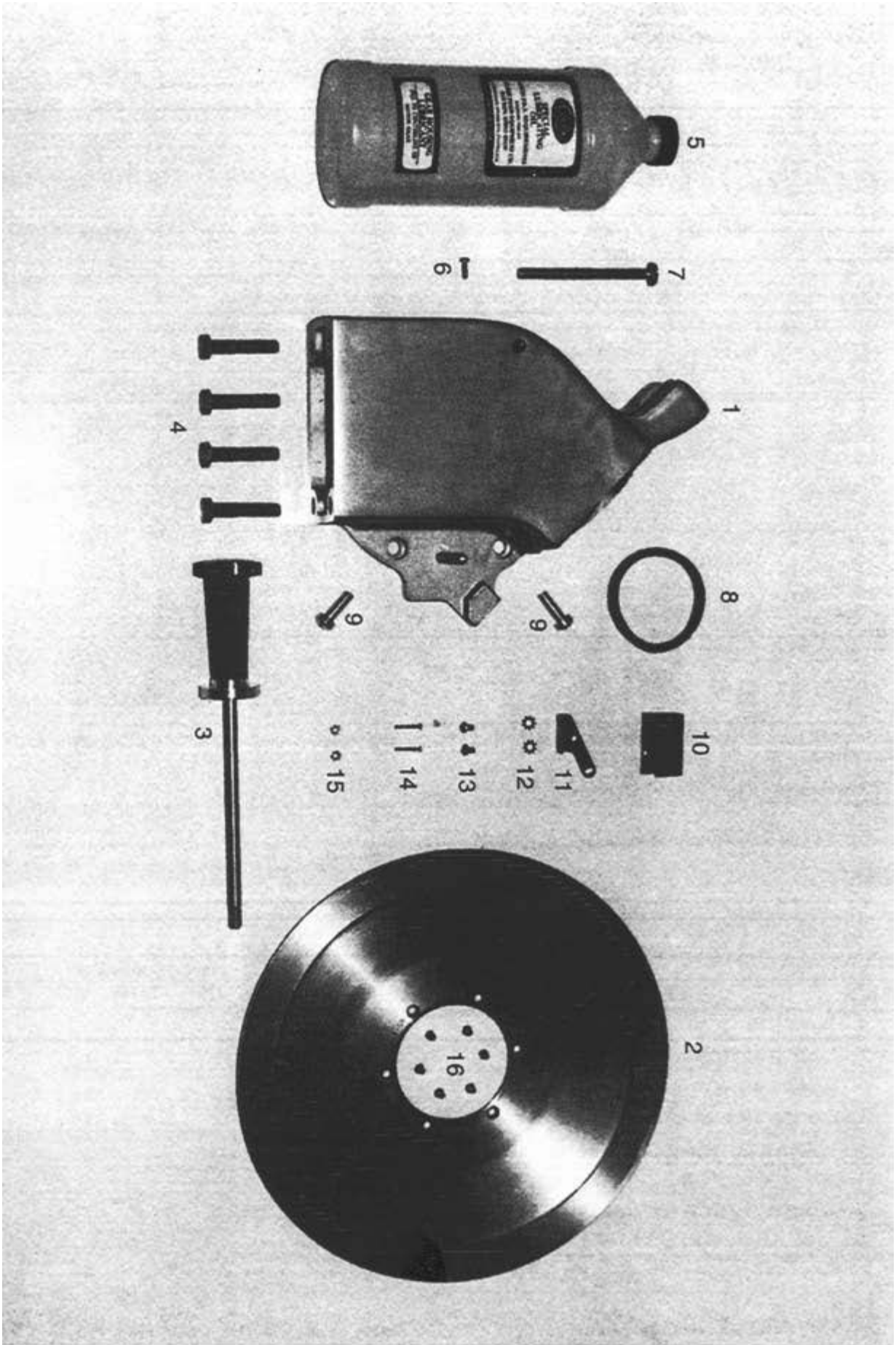

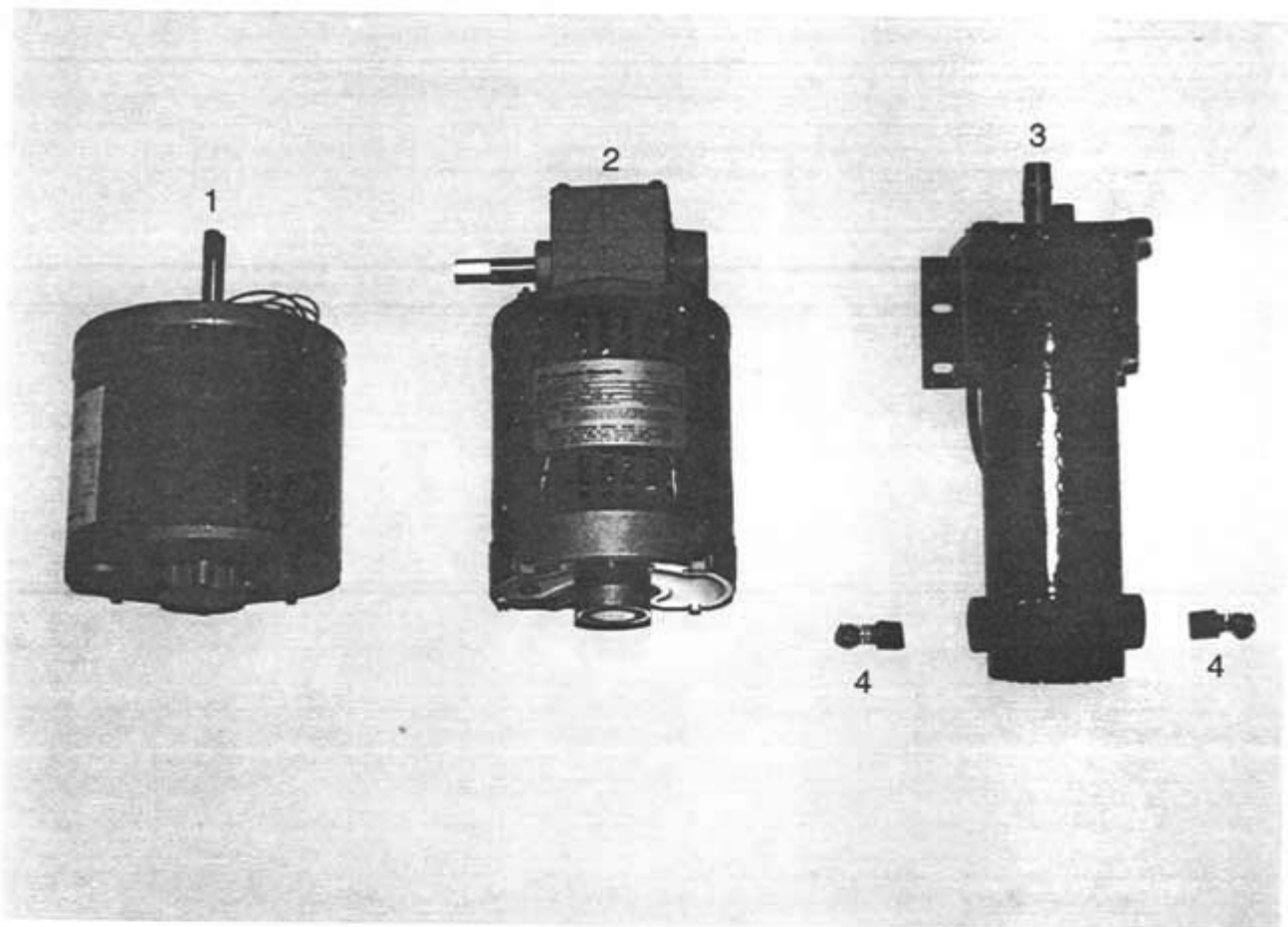

MOTORS

ITEM	DESCRIPTION	PART NUMBER	MODEL NUMBER				ALL
			2500	2750	2875V	2850V	
1	KNIFE MOTOR 1/2 HP-115V-60HZ-1PH	834-8F					X
	KNIFE MOTOR 1/2 HP-220V-60HZ-1PH	834-11F					X
	KNIFE MOTOR 1/2 HP-220V-50HZ-1PH	834-10F					X
	KNIFE MOTOR-CANADA 1/2HP-115V-60HZ-1PH	834-9F					X
2	CHUTE MOTOR 2 SPEED-115V-60HZ-1PH	970-1		X			
	CHUTE MOTOR 2 SPEED-220V-50,60HZ-1PH	970-1-220		X			
3	CHUTE MOTOR VARIABLE SPEC D.C.	763-EVM			X		X
4	● MOTOR BRUSH 1/4"X 1/2" (2 REQ'D)	763-EVM-B			X		X

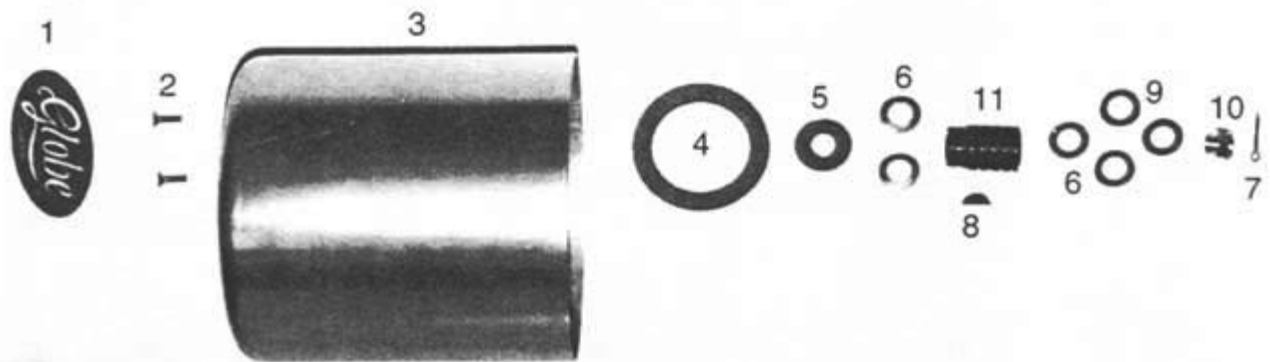

KNIFE MOTOR HARDWARE

ALL MODELS

ITEM	DESCRIPTION	PART NUMBER
1	GLOBE LOGO DECAL	871-2
2	MOTOR SHELL SCREW (2 REQ'D)	834-S
3	MOTOR SHELL 1/2 HP	796-L
	MOTOR SHELL 1/2 HP - CANADA	796-C
4	CORK MOTOR GASKET	395
	MOTOR GEAR HARDWARE KIT	965
5	● MOTOR GEAR FLAT WASHER	809
6	● MOTOR GEAR BOWED WASHER (4 REQ'D)	810
7	● MOTOR SHAFT COTTER PIN	390
8	● MOTOR SHAFT KEY	375-A
9	● MOTOR GEAR FLAT WASHER (2 REQ'D)	375
10	● MOTOR SHAFT NUT	808
11	MOTOR GEAR	373
NOT SHOWN	MOTOR SHELL 1/2 HP - RESET BUTTON COVER - CANADA	796-D

KNIFE PLATE

ALL MODELS

ITEM	DESCRIPTION	PART NUMBER
	KNIFE PLATE ASSEMBLY WITH FIBRE GEAR	972-P-AS
	KNIFE PLATE ASSEMBLY WITH BRONZE GEAR	972-P-AS-1
	KNIFE PLATE ASSEMBLY WITH NYLON GEAR	972-P-AS-2
1	● NUT, SHAFT	747-8
2	● GASKET, SHAFT	972-9P
3	● SHAFT	972-2P
4	● RING, RETAINING	747-16
5	● KEY	747-18
6	● KNIFE PLATE	972-1P
7	● BEARING, SMALL	972-8P
8	● SPACER, BEARING	972-4P
9	● BEARING, LARGE	972-5P
10	● RING, RETAINING	972-7P
11	● COVER, BEARING	972-6P
12	● NUT, LOCK	972-3P
13	● GEAR, FIBRE	747-17
	● GEAR, BRONZE	747-17B
	● GEAR, NYLON	747-17N

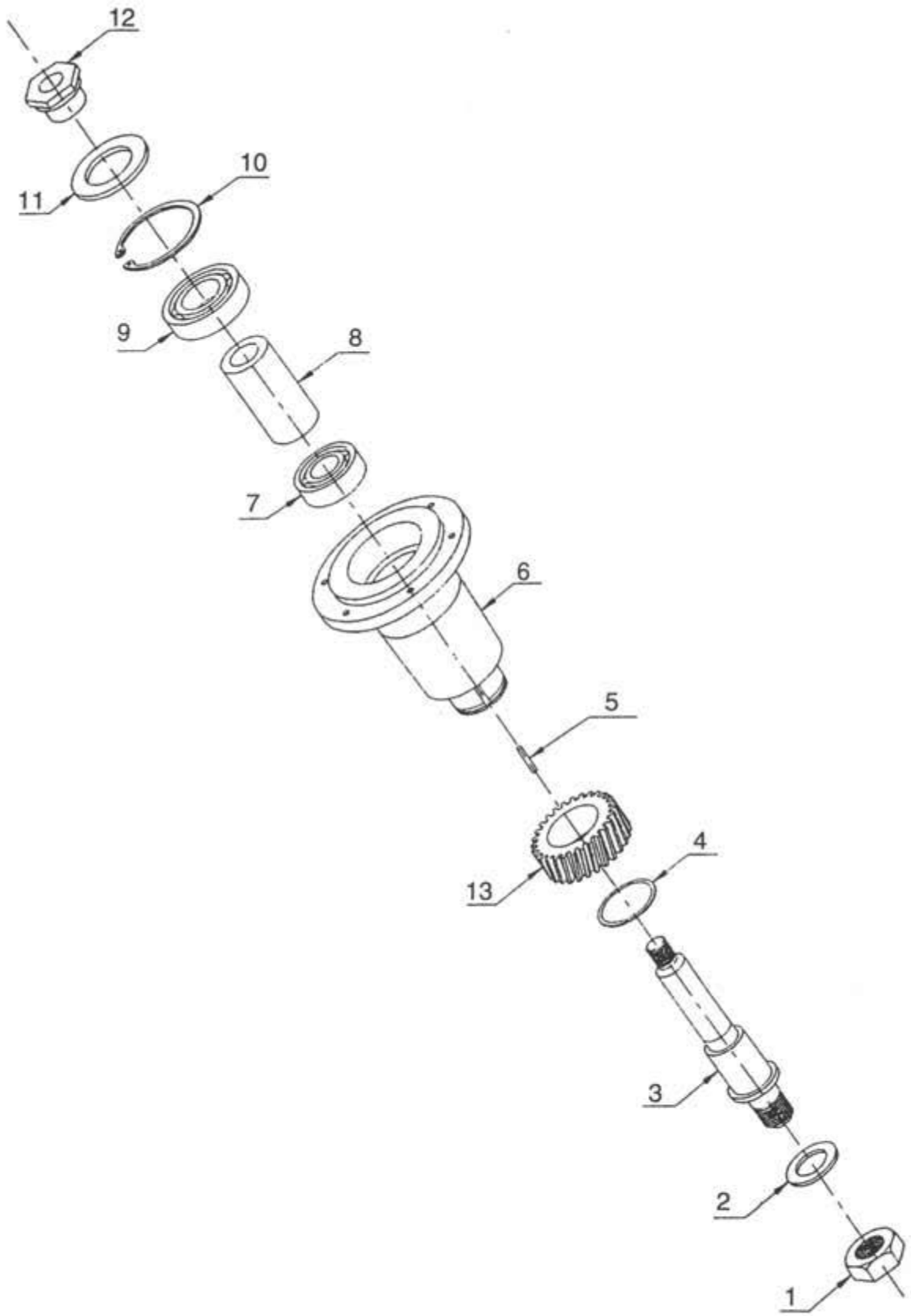

KNIFE COVER AND RIM GUARD

ALL MODELS

ITEM	DESCRIPTION	PART NUMBER
	KNIFE COVER ASSEMBLY	972-C-AS
1	● KNIFE COVER	955-1
2	● COVER KNOB	943-2
3	● KNIFE COVER HUB	972-1C
4	● HUB NUT (4 REQ'D)	955-3
5	● COVER KNOB SCREW (STANDARD)	726-6
	● SCRAPER SCREW (OPTIONAL)	966-5
6	● COVER KNOB / SCRAPER NUT	943-2
7	KNIFE SCRAPER - (OPTIONAL)	966-4
	RIM GUARD ASSEMBLY	942-AS
8	● UPPER RIM GUARD KNOB	821-4
9	● UPPER RIM GUARD	942-2
10	● KNIFE COVER STOP PIN (2 REQ'D)	822-5
11	● RIM GUARD HINGE SCREW	942-3
14	● LOWER RIM GUARD	942-1
12	RIM GUARD SCREW - UPPER	944-1A
13	RIM GUARD SCREW - LOWER	944-2A
15	UPPER RIM GUARD ARM	944-1
16	LOWER RIM GUARD ARM	944-2
17	GEAR HOUSING ARM SCREW (4 REQ'D)	944-3

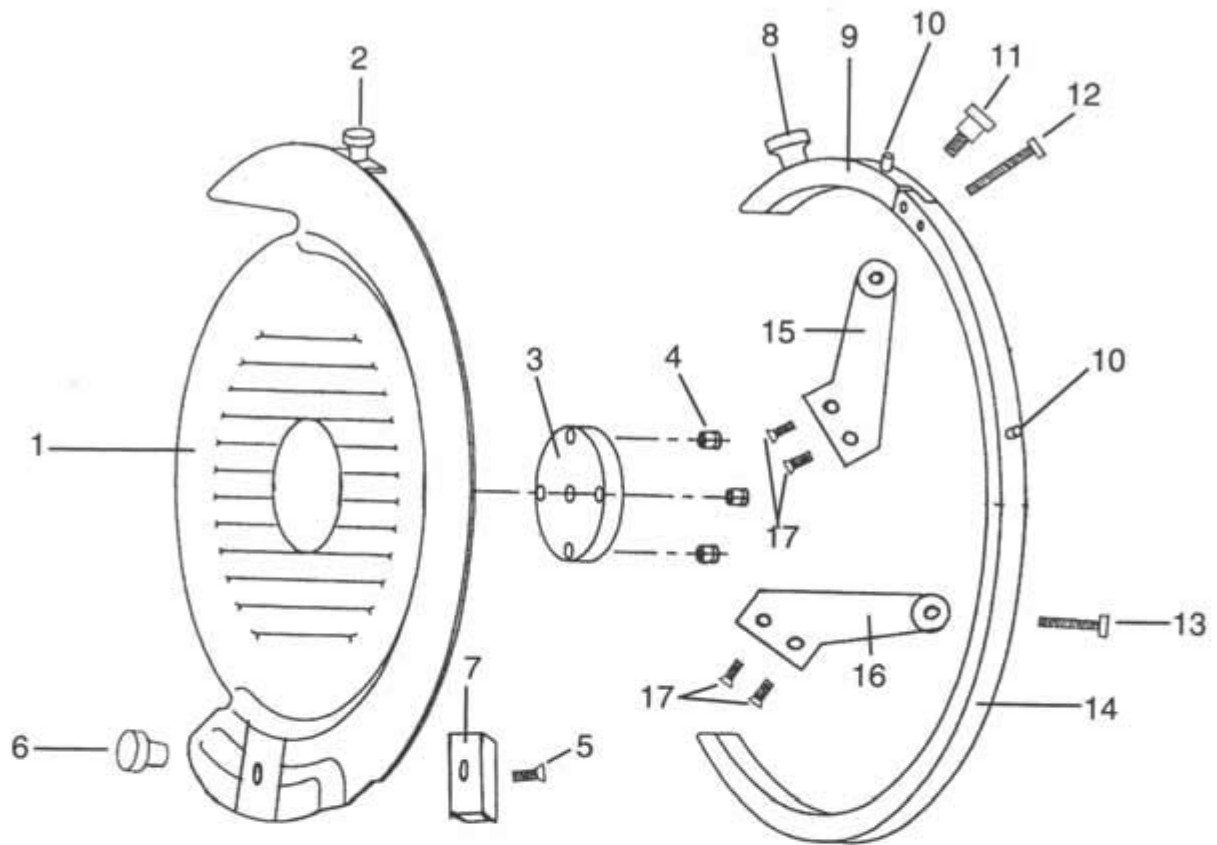

SHARPENER

ALL MODELS

ITEM	DESCRIPTION	PART NUMBER
	SHARPENER ASSEMBLY WITHOUT COVER	10-A-1
1	● SHARPENER STONE NUT	228
2	● SHARPENER STONE WASHER (STEEL)	229
3	● SHARPENER STONE WASHER (FIBRE)	229-1
4	● SHARPENER TRUING STONE	213
5	● SHARPENER GRINDING STONE	214-A
	STONE SET (213 + 214-A)	214-5
6	● SHARPENER TRUING SHAFT ASSEMBLY	467-AS
7	● SHARPENER GRINDING SHAFT ASSEMBLY	463-AS
8	● SHARPENER HINGE BOLT NUT	286
9	● SHARPENER BRACKET	448
10	● SHARPENER HOUSING	450-H
11	● SHARPENER LOCK ROD ASSEMBLY	456-AS
12	● SHARPENER LOCK SPRING	458
13	● SHARPENER GEAR	455
14	● SHARPENER GEAR RETURNING SPRING	460
15	● SHARPENER GEAR SPACER RING	459
16	● SHARPENER GEAR SPACER RING SCREW	459-1
17	● SHARPENER HANDLE	495
18	● SHARPENER HANDLE SET SCREW	495-1
19	● SHARPENER LOCK KNOB	461
20	● SHARPENER LOCK ROD KNOB PIN	287-2
21	● SHARPENER BRACKET CLAMP SCREW WASHER	134
22	● SHARPENER HINGE BOLT WASHER	286-1
23	● SHARPENER BRACKET CLAMP SCREW	477
24	● SHARPENER HINGE BOLT	475
25	● SHARPENER SLEEVE PIN	300
26	● SHARPENER STOP BUSHING SCREW	470-1
27	● SHARPENER TRUING STONE STOP ASSEMBLY	471-AS
34	● BALL, STOP BUSHING	290
35	● SPRING, STOP BUSHING	238
36	● SHIM, SHARPENER BRACKET	448-1
37	● SCREW, SHAFT RETAINING	462-1
38	● PIN, STOP SHAFT	464
39	● SPRING	465
40	● SHAFT	463

SHARPENER (CONTINUED)

ALL MODELS

ITEM	DESCRIPTION	PART NUMBER
28	SHARPENER COVER	825
29	SHARPENER COVER HINGE SCREW	825-1
30	SHARPENER COVER HINGE SCREW WASHER	825-2
31	SHARPENER COVER HINGE NUT	825-3
32	SHARPENER COVER WARNING DECAL (ENGLISH)	967-2
	SHARPENER COVER WARNING DECAL (SPANISH)	967-2S
33	SHARPENER COVER TENSION WASHER	761-6

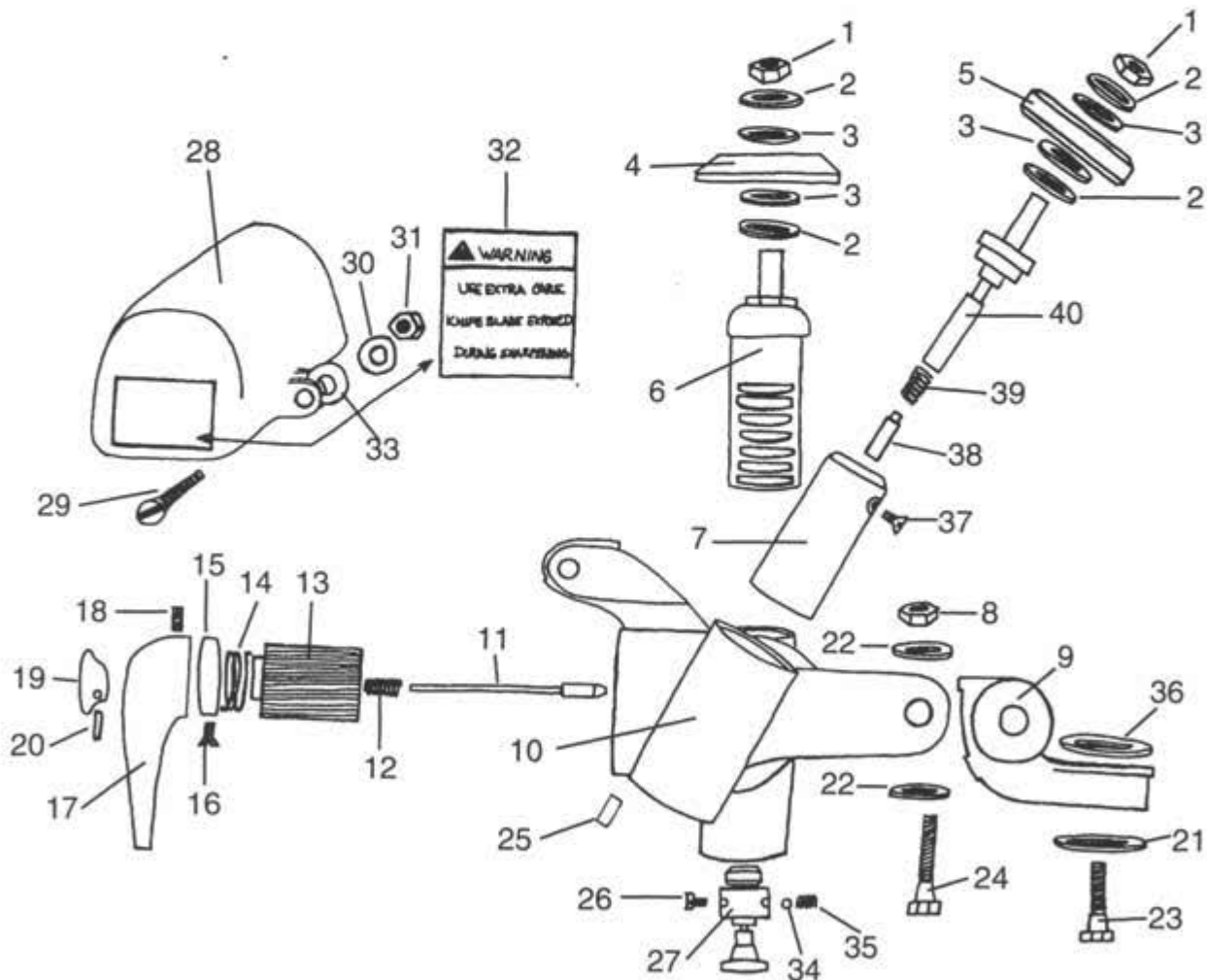

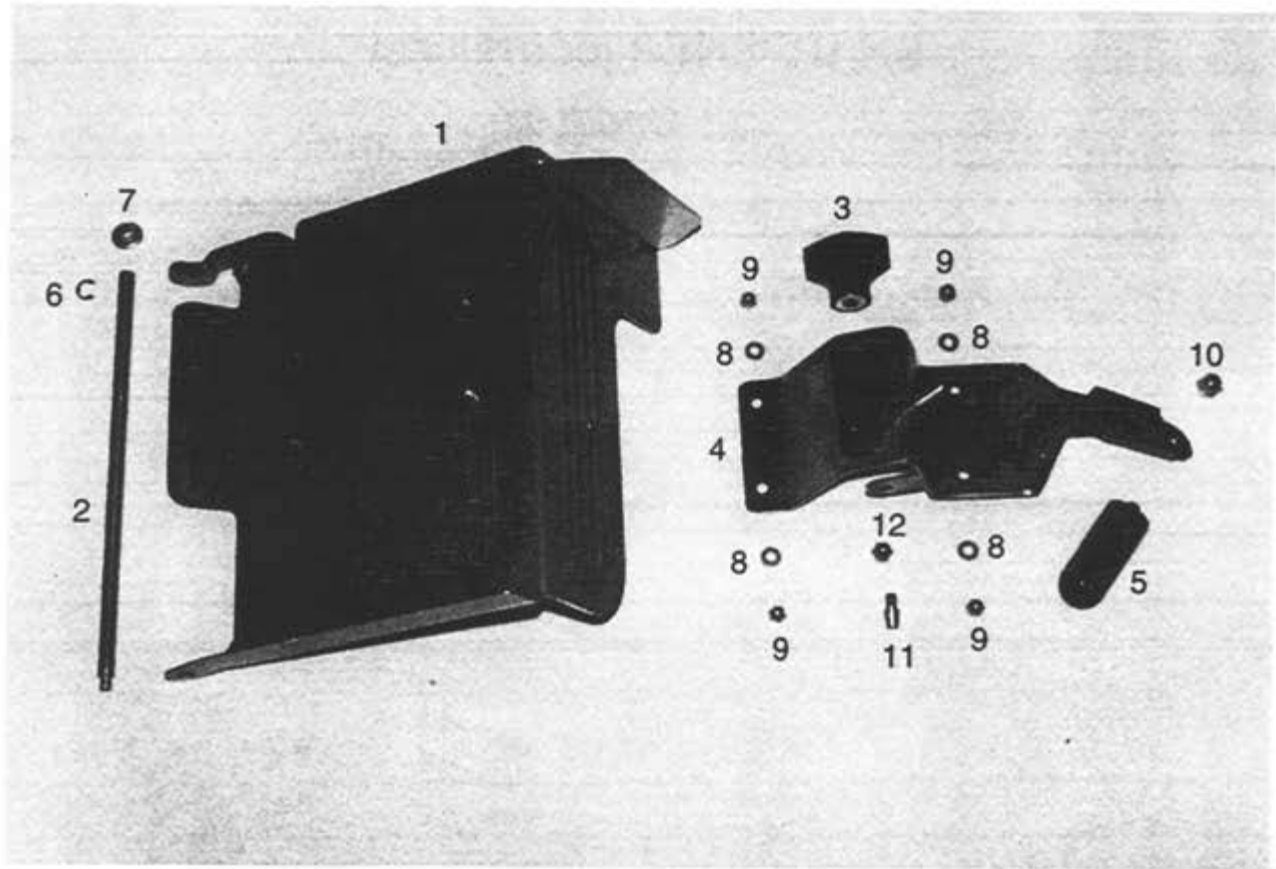

STAINLESS STEEL CHUTE AND SUPPORT

ITEM	DESCRIPTION	PART NUMBER	MODEL NUMBER				
			2500	2750	2875V	2850V	ALL
	12" ASSEMBLY - S.S. CHUTE W/O PRONGS	102-AS-8	X				
	12" ASSEMBLY - S.S. CHUTE W/ PRONGS	102-AS-9		X	X	X	
	17" (opt.) ASSEM.-S.S. CHUTE W/ PRONGS	102-AS-10					X
1	● STAINLESS STEEL CHUTE 12"	962-S					X
	● STAINLESS STEEL CHUTE 17"	962-L					X
2	● END WEIGHT ROD 12"	741-1S					X
	● END WEIGHT ROD 17"	741-1L					X
3	● CHUTE SUPPORT NUT	798-B					X
4	● CHUTE SUPPORT	962-1					X
5	● CHUTE HANDLE	482-B					X
6	● END WEIGHT ROD CLIP	741-1R					X
7	● END WEIGHT ROD CAP NUT	962-8					X
8	● FLAT WASHER (4 REQ'D)	825-2					X
9	● SUPP. MOUNTING ACORN NUT (4 REQ'D)	962-6					X
10	● ACORN NUT	699-32					X
11	● LOCK BACK STUD	962-5					X
12	● ACORN NUT	962-7					X

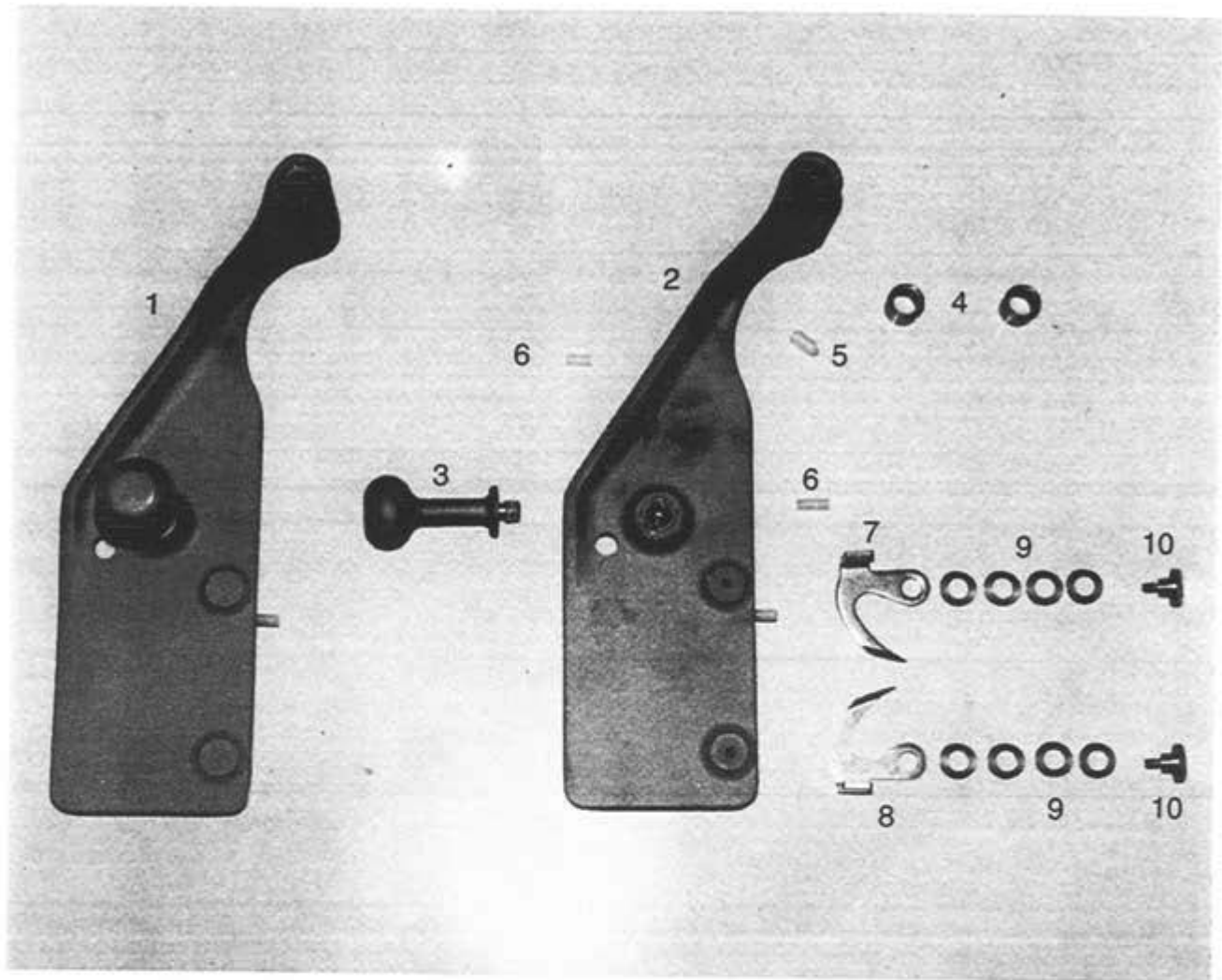

END WEIGHTS

ITEM	DESCRIPTION	PART NUMBER	MODEL NUMBER				
			2500	2750	2875V	2850V	ALL
	S. S. END WEIGHT ASSEM. W/O PRONGS	741-SS-AS	X				
	S. S. END WEIGHT ASSEM. W/ PRONGS	741-SS-APC		X	X	X	
1	● S. S. MANUAL END WEIGHT	741-SS1	X				
2	● S. S. AUTOMATIC END WEIGHT	741-SS2		X	X	X	
3	● S. S. END WEIGHT HANDLE	741-SS3					X
4	● END WEIGHT BUSHING (2 REQ'D)	741-6/741-6L					X
5	● END WEIGHT REST BUMPER	741-4A					X
6	● END WEIGHT SPACER BUMPER (2 REQ'D)	741-5B					X
7	● END WEIGHT PRONG (RIGHT)	741-PC2		X	X	X	
8	● END WEIGHT PRONG (LEFT)	741-PC3		X	X	X	
9	● PRONG SPRING WASHER (8 REQ'D)	741-PC5		X	X	X	
10	● PRONG SHOULDER SCREW (2 REQ'D)	741-SS4		X	X	X	

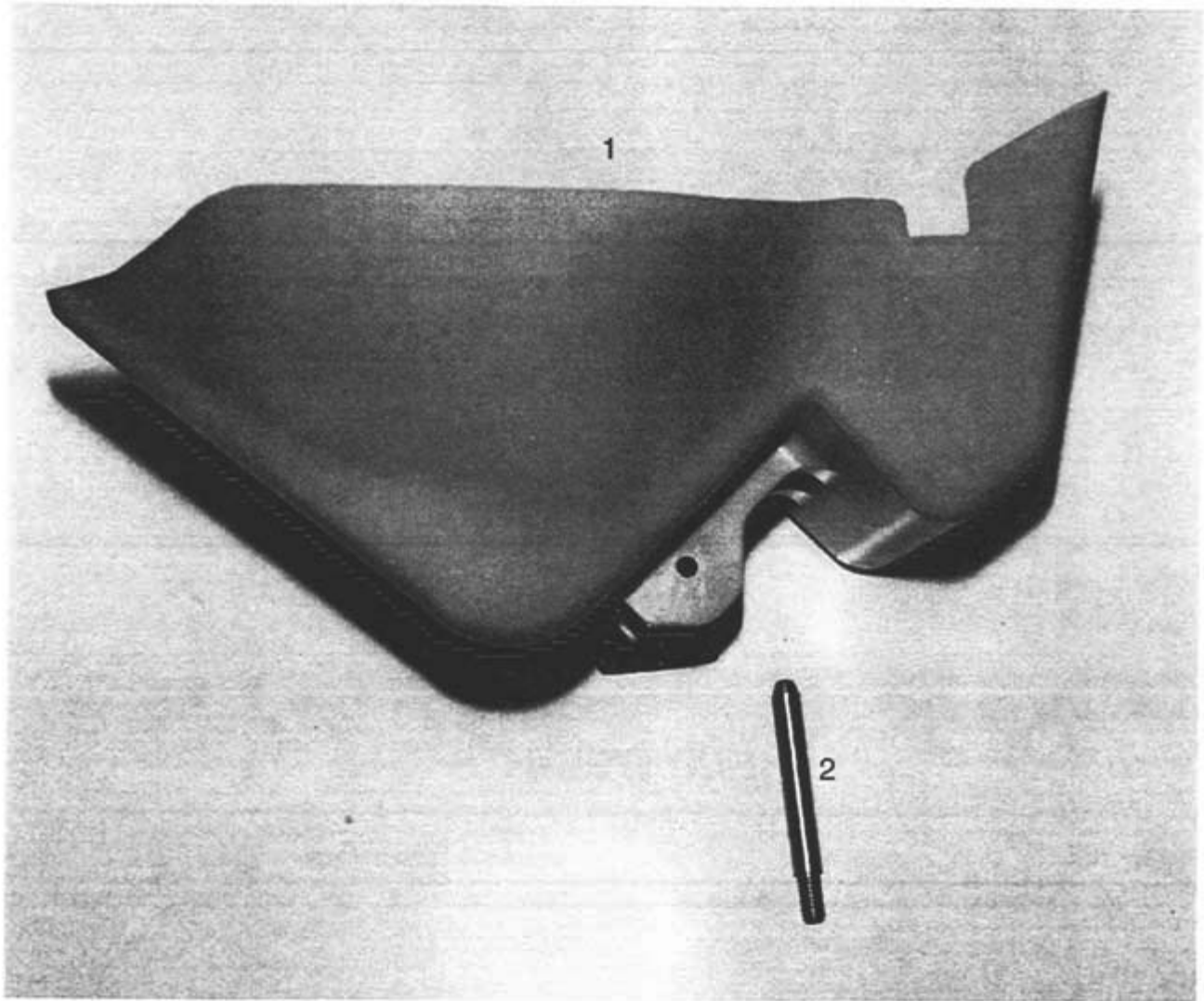

SLICE DEFLECTOR AND PIN

ALL MODELS

ITEM	DESCRIPTION	PART NUMBER
1	SLICE DEFLECTOR	968
2	SLICE DEFLECTOR PIN	968-1

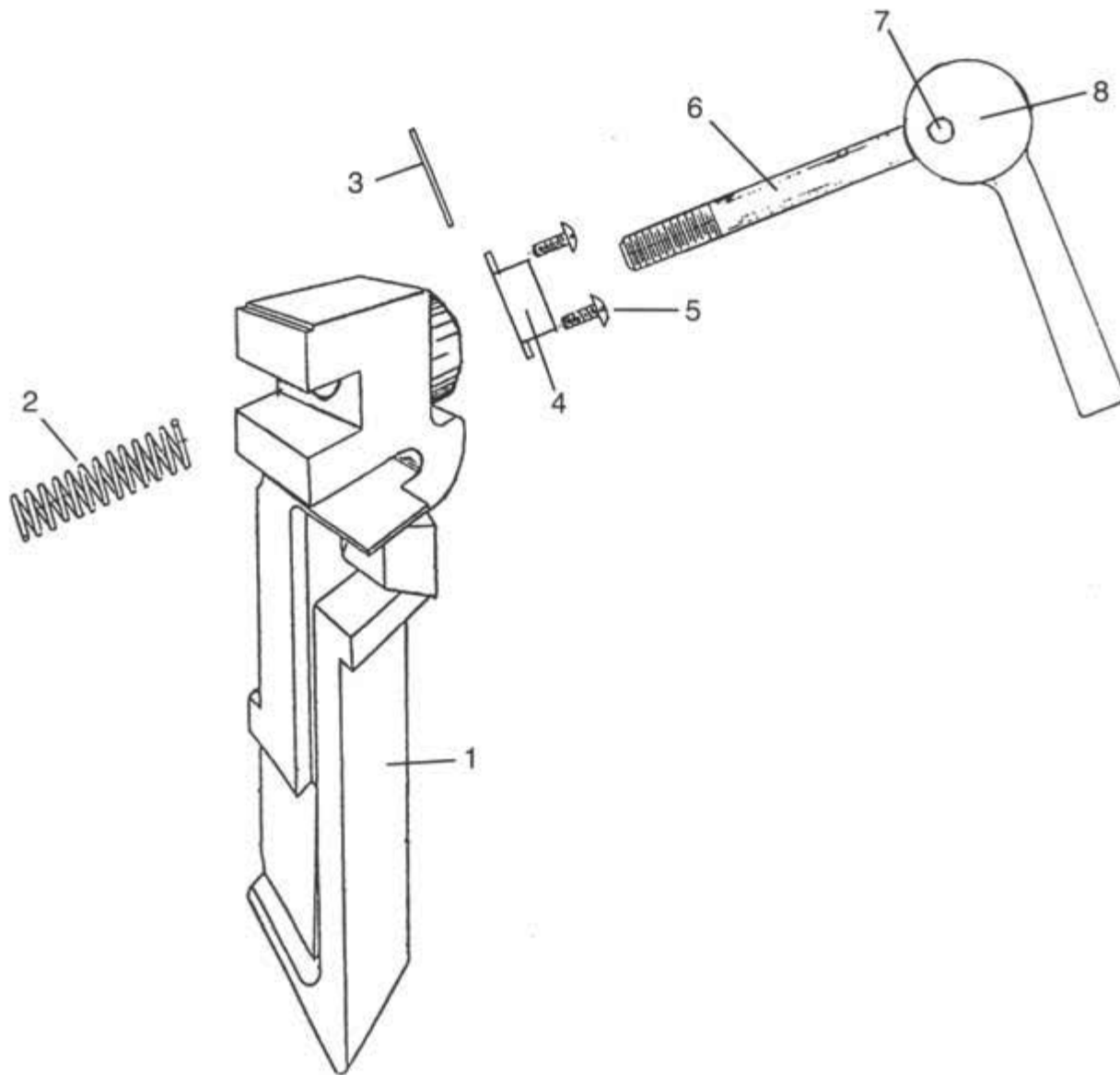

QUICK RELEASE AUTOMATIC CHAIN SLIDE

ALL AUTOMATIC MODELS

ITEM	DESCRIPTION	PART NUMBER
1	CHAIN SLIDE ASSEMBLY	916-AS
2	SPRING, CHAIN SLIDE	916-4
3	SHIM, CAM	916-5A,5B,5C
4	WASHER, CAM	916-5L
5	SCREW, CAM WASHER (2 REQ'D)	916-6
6	BOLT, CHAIN SLIDE EYE	916-1
7	PIN, CAM	916-3
8	CAM, CHAIN SLIDE	916-2

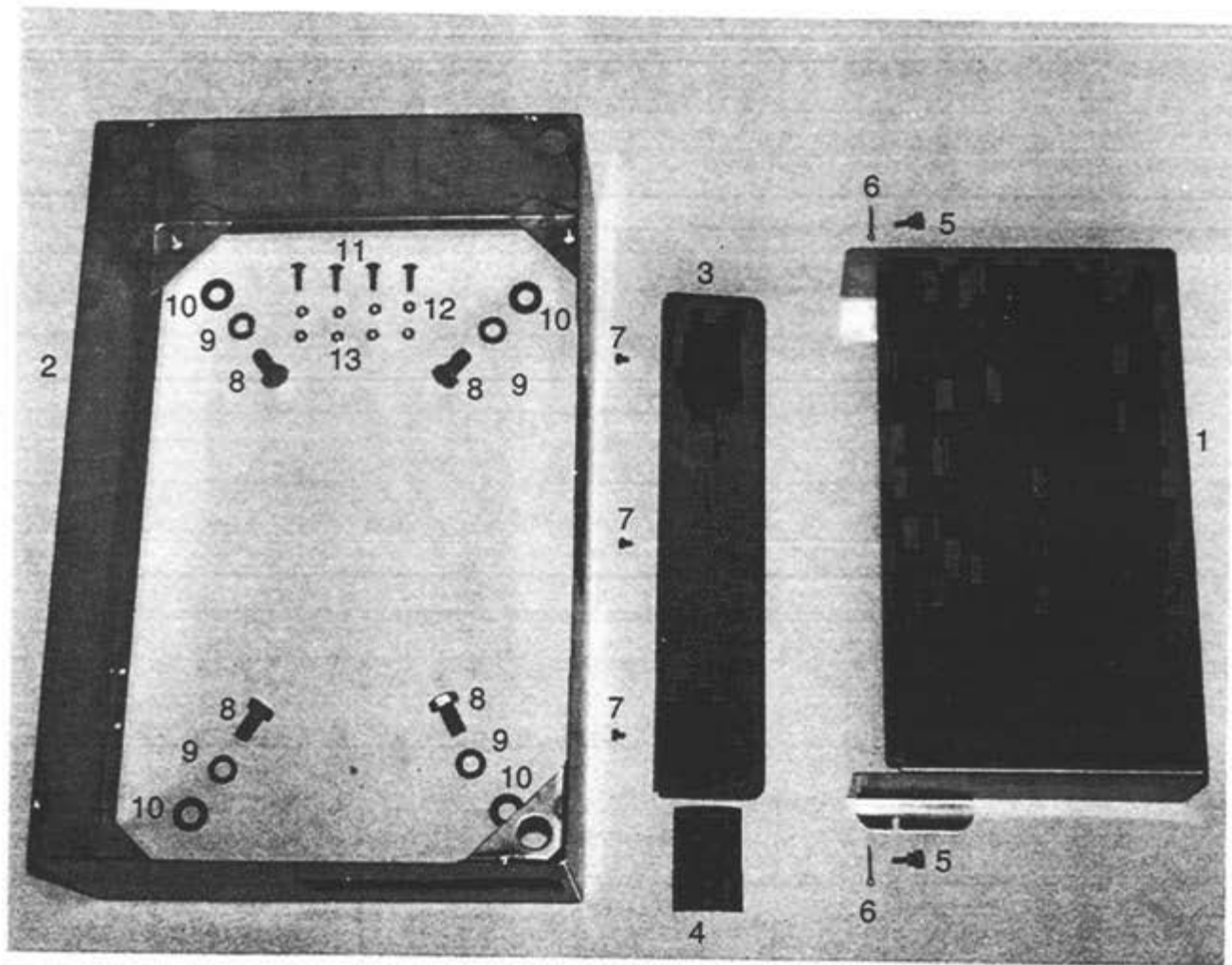

AUTOMATIC BASE APRON AND CHAIN GUARD

ITEM	DESCRIPTION	PART NUMBER	MODEL NUMBER			
			2750	2875V	2850V	ALL
1	CHAIN GUARD	917				X
2	BASE APRON	922			X	
	BASE APRON	923	X	X		
3	TOP CHAIN GUARD	910-A				X
4	QUICK RELEASE DECAL	916-7				X
5	CHAIN GUARD THUMB SCREW (2 REQ'D)	917-2				X
6	COTTER PIN (2 REQ'D)	390				X
7	TOP GUARD MOUNTING SCREW (3 REQ'D)	889				X
8	APRON SCREW (4 REQ'D)	813				X
9	APRON LOCK WASHER (4 REQ'D)	815				X
10	APRON FLAT WASHER (4 REQ'D)	881-4				X
11	CARRIAGE SCREW (4 REQ'D)	971-9				X
12	NYLON HEX NUT (4 REQ'D)	971-10				X
13	HEX NUT (4 REQ'D)	760-5		X	X	

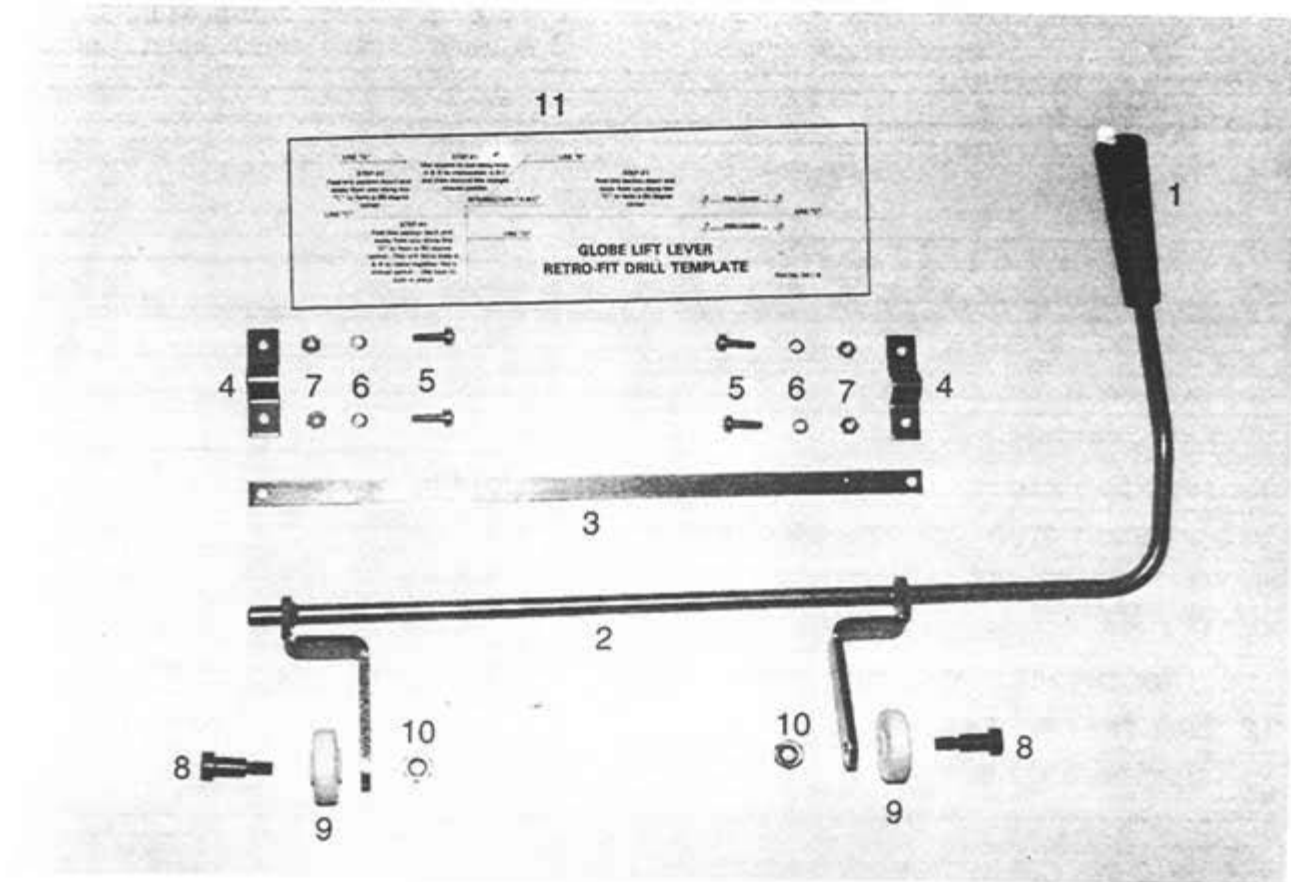

LIFT LEVER SYSTEM

ITEM	DESCRIPTION	PART NUMBER	MODEL NUMBER			
			2750	2875V	2850V	ALL
	LIFT LEVER KIT	951-ASW	X	X		
1	● KNOB	951-8	X	X		
2	● LIFT LEVER	951-3W	X	X		
3	● STOP BAR	951-6	X	X		
4	● PIVOT ROD CLIP (2 REQ'D)	951-2	X	X		
5	● SCREW (4 REQ'D)	350	X	X		
6	● LOCK WASHER (4 REQ'D)	925-26	X	X		
7	● NUT (4 REQ'D)	760-5	X	X		
8	● SHOULDER SCREW (2 REQ'D)	951-5	X	X		
9	● ROLLER (2 REQ'D)	951-7	X	X		
10	● NUT (2 REQ'D)	478-1	X	X		
11	● DRILL TEMPLATE	951-9	X	X		

AUTOMATIC CHUTE DRIVE SYSTEM

ITEM	DESCRIPTION	PART NUMBER	2750	MODEL NUMBER		
				2875V	2850V	ALL
1	38 LINK DRIVE CHAIN	892-2		X		
	44 LINK DRIVE CHAIN	970-10	X			
	50 LINK DRIVE CHAIN	936			X	
2	18 & 36 TOOTH DRIVE SPROCKET	762-3				X
3	36 TOOTH BACK SPROCKET	762-2				X
4	SPROCKET BARRIER	762-5				X
5	BARRIER SCREW (2 REQ'D)	762-6				X
6	SPROCKET BUSHING (2 REQ'D)	762-4				X
7	SPROCKET STUD (2 REQ'D)	764-12				X
8	SPROCKET STUD LOCK WASHER (2 REQ'D)	815				X
9	SPROCKET STUD NUT (2 REQ'D)	646				X
10	18 TOOTH CHUTE MOTOR SPROCKET	762-1EVM		X	X	
11	11 TOOTH CHUTE MOTOR SPROCKET	619	X			
12	SPROCKET SET SCREW	346				X
13	SPROCKET SET SCREW	346				X
14	64 LINK SLIDE DRIVE CHAIN ASSEMBLY	766-2BAS				X
15	● CHAIN CONNECTOR PIN (2 REQ'D)	766-4				X
16	● CHAIN CONNECTOR ROLLER	766-5				X
17	● CHAIN CONNECTOR	612				X
18	● CHAIN CONNECTOR CLIP	766-6				X
19	● MASTER LINK	610				X
<small>NOT SHOWN</small>	CHAIN WARNING LABEL - ENGLISH	967-3				X
<small>NOT SHOWN</small>	CHAIN WARNING LABEL - SPANISH	967-3S				X

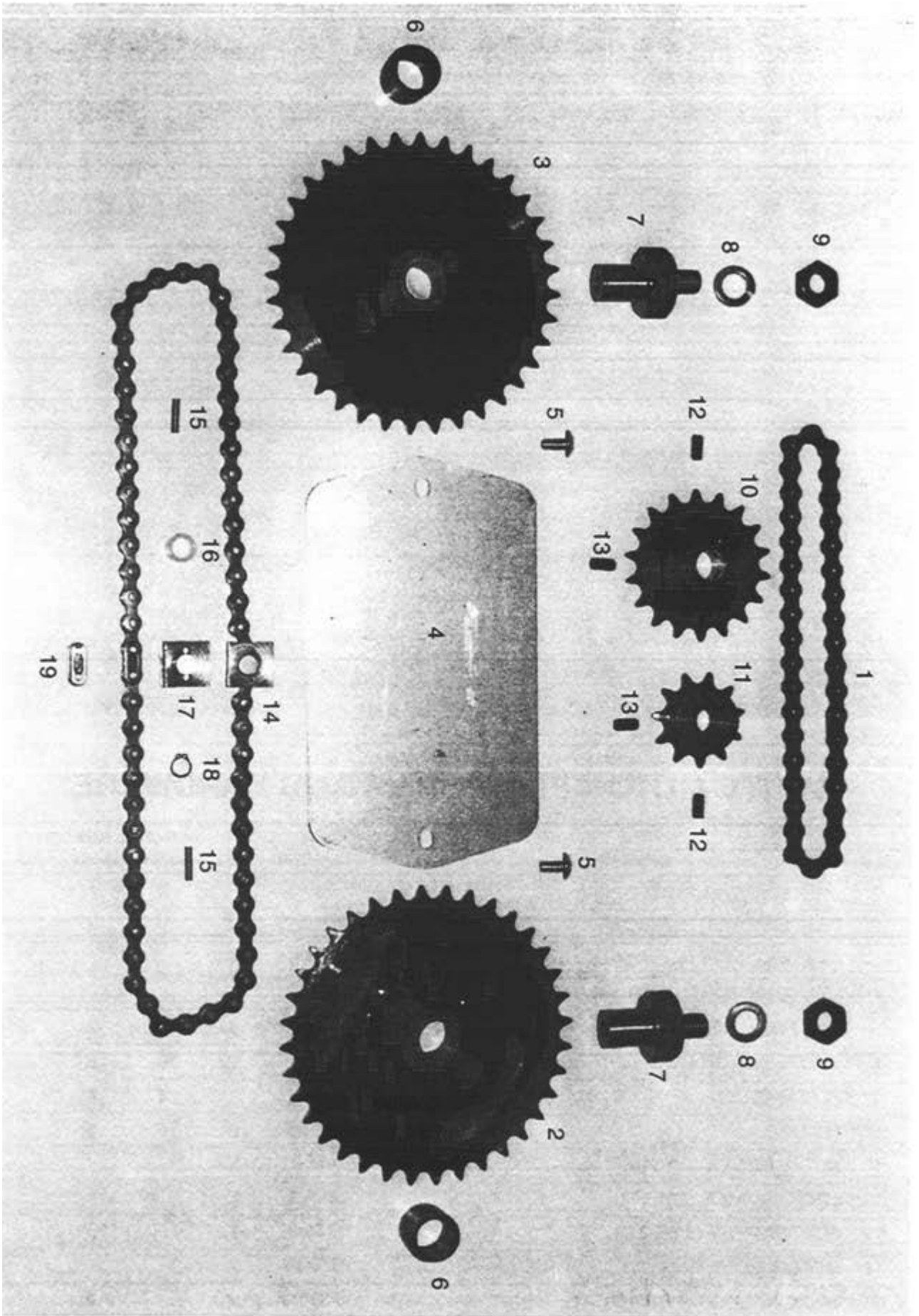

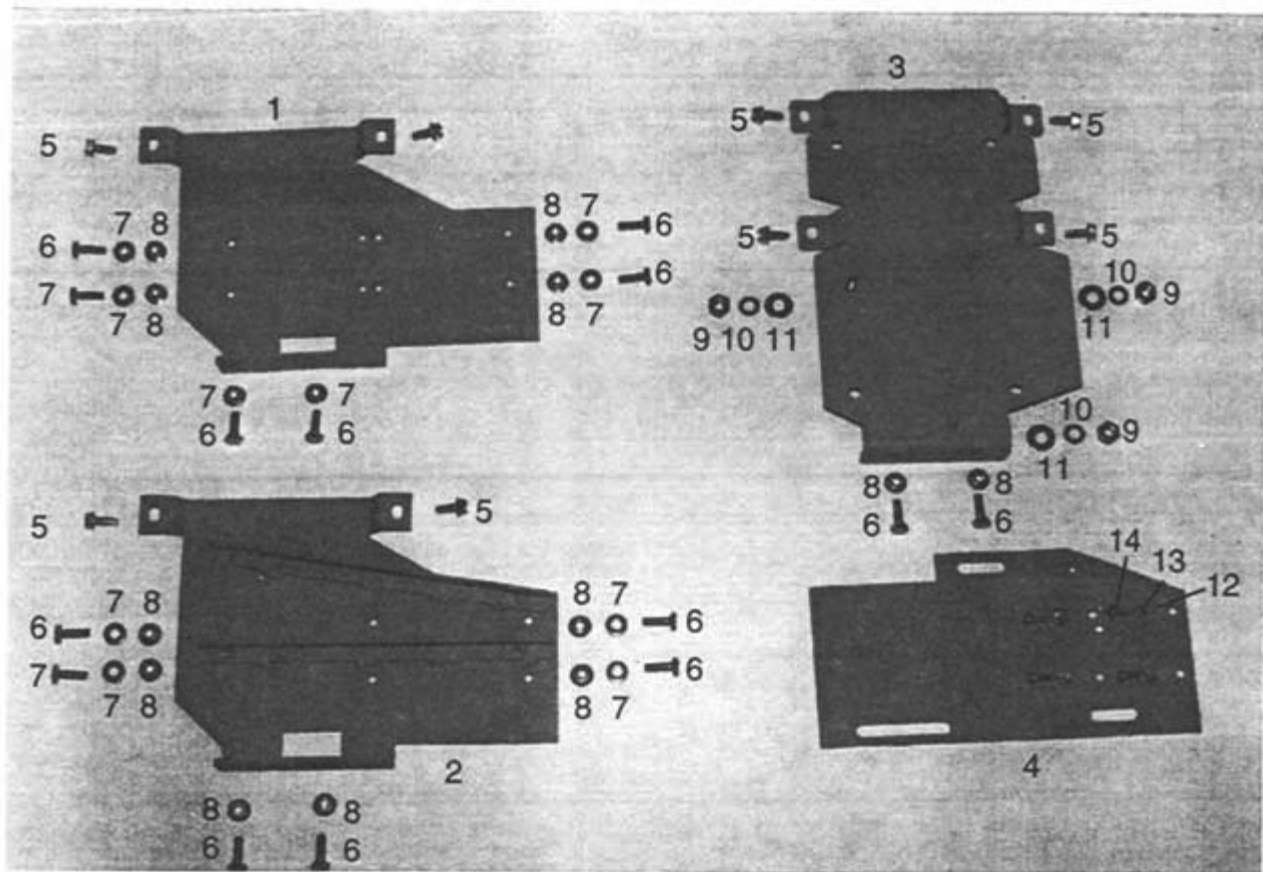

CHUTE MOTOR PLATFORMS AND HARDWARE

ITEM	DESCRIPTION	PART NUMBER	MODEL NUMBER			
			2750	2875V	2850V	ALL
1	CHUTE MOTOR PLATFORM	763-EVM1		X		
2	CHUTE MOTOR PLATFORM	763-EAS			X	
3	CHUTE MOTOR PLATFORM	888-A	X			
4	CHUTE MOTOR MOUNTING BASE	970-9	X			
5	PLATFORM SCREW	888-1	4	2	2	
6	CHUTE MOTOR PLATFORM SCREW	627-C	2	6	6	
7	FLAT WASHER	888-2		4	4	
8	FLANGE NUT	851-3FN	2	6	6	
9	NUT (3 REQ'D)	478-1	X			
10	LOCK WASHER (3 REQ'D)	245-A	X			
11	FLAT WASHER (3 REQ'D)	733-3	X			
12	MOTOR MOUNTING NYLON SPACER (4 REQ'D)	970-1N	X			
13	LOCK WASHER (4 REQ'D)	970-1W	X			
14	MOTOR MOUNTING SCREW (4 REQ'D)	970-1S	X			

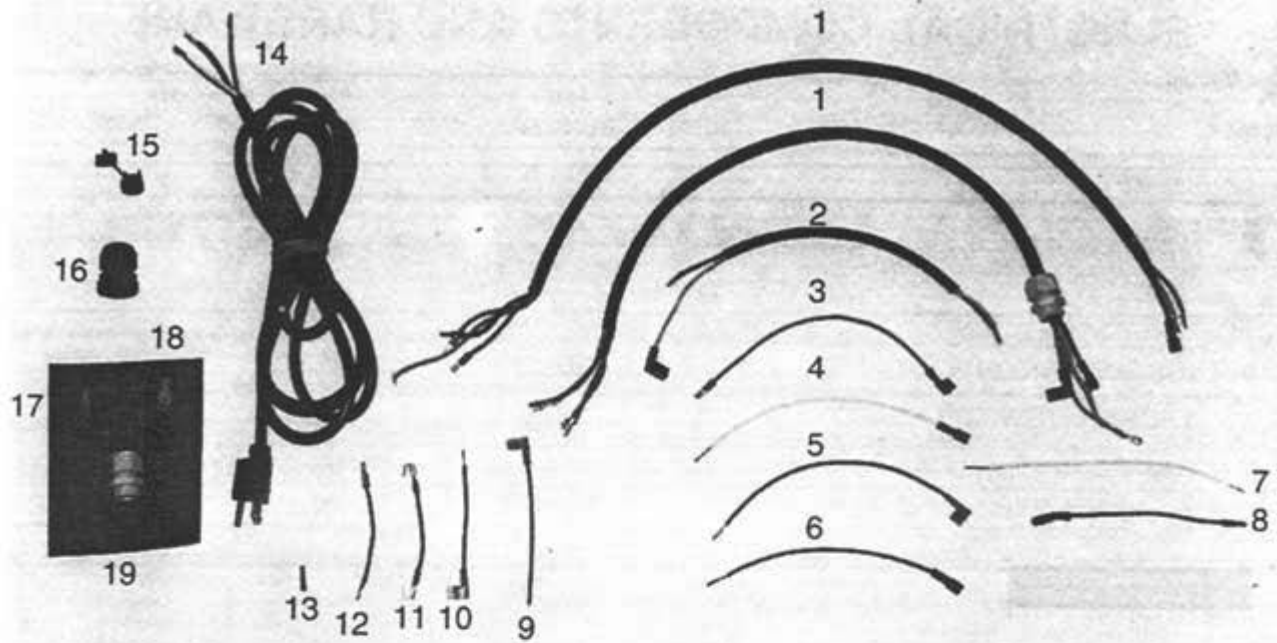

WIRING HARNESS AND COMPONENTS

ITEM	DESCRIPTION	PART NUMBER	MODEL NUMBER				
			2500	2750	2875V	2850V	ALL
1	MAIN WIRING HARNESS	952-16	X				
	MAIN WIRING HARNESS	952-17		X	X	X	
	GEAR MOTOR WIRING HARNESS	970-3		X			
2	PILOT LAMP HARNESS	952-20	X				
3	SWITCH TO SWITCH JUMPER	956-11		X			
4	MICRO SWITCH COMMON - WHITE WIRE	956-4					X
5	RELAY WIRE TERMINAL 5	956-6					X
6	MICRO SWITCH N.O.-BLACK WIRE	956-3					X
7	POWER CORD TO MOTOR - WHITE WIRE	956-8					X
8	SWITCH TO SWITCH JUMPER	956-9			X	X	
9	RELAY WIRE TERMINAL B - BLACK WIRE	956-5					X
10	RELAY WIRE TERMINAL A - BLUE WIRE	956-7					X
11	SWITCH JUMPER WIRE	956-1	X				
12	SWITCH JUMPER WIRE	956-2		X	X	X	
13	FEMALE WIRE TERMINAL	763-EVC-10		X	X	X	
14	POWER CORD	132-3					X
15	POWER CORD STRAIN RELIEF	877					X
16	LIQUID TIGHT FITTING - BLACK	952-12					X
17	SMALL SPLICE CONNECTOR	869-A1					X
18	LARGE SPLICE CONNECTOR	952-15					X
19	LIQUID TIGHT FITTING - GRAY	970-5		2	4	4	

ELECTRICAL COMPONENTS AND HARDWARE

ITEM	DESCRIPTION	PART NUMBER	MODEL NUMBER				
			2500	2750	2875V	2850V	ALL
1	FACE PLATE	971-5			X	X	
2	FACE PLATE	970-4		X			
3	MOUNTING SCREW (6 REQ'D)	763-EVC4		X	X	X	
4	FACE PLATE GASKET	763-EVC7		X	X	X	
5	TOGGLE SWITCH BOOT	952-13					X
6	3 POSITION SWITCH GUARD	970-6		X			
7	TOGGLE SWITCH LOCK RING	648-4		X	X	X	
8	3 POSITION SWITCH	970-2		X			
9	RELAY BRACKET SCREW (2 REQ'D)	852-1					X
10	RELAY BRACKET	952-1					X
11	ELECTRICAL WIRING BOX	971-4		X	X	X	
12	SWITCH BOX	952-4	X				
13	SWITCH BOX SCREW	854-6	X				
	MAIN SWITCH	952-10		X	X	X	
14	● N.O. CONTACT	952-10-NO		X	X	X	
15	● N.C. CONTACT	952-10-NC		X	X	X	
16	● SWITCH BASE	952-10-BS		X	X	X	
17	● OPERATOR PUSH BOTTONS	952-10-OP		X	X	X	
18	MAIN SWITCH BOOT	952-10-B		X	X	X	
19	WIRE CABLE LOCK TIES (2 REQ'D)	872					X
20	HARNESS CLAMP (2 REQ'D)	869-A2					X
21	CLAMP SCREW (2 REQ'D)	852-1					X
22	SWITCH BOX COVER	952-5	X				
23	SWITCH BOX COVER SCREW (2 REQ'D)	889	X				
24	ELECTRICAL WIRING BOX COVER	971-8		X	X	X	
25	WIRING BOX COVER SCREW (3 REQ'D)	889		X	X	X	
26	GEAR HOUSING INTERLOCK SWITCH	854-1					X
27	MAIN POWER RELAY 115 VAC	952-9					X
	MAIN POWER RELAY 220 VAC	952-27					X
28	SCREW (2 REQ'D)	952-21					X
29	LOCK WASHER (2 REQ'D)	952-22					X
30	HEX NUT (2 REQ'D)	952-23					X
31	VARIABLE SPEED CONTROL ASSEMBLY	971-1			X	X	
	● SPEED CONTROL P.C.B. 115/220 VAC	971-1B			X	X	
	● PLASTIC ENCLOSURE	971-6			X	X	

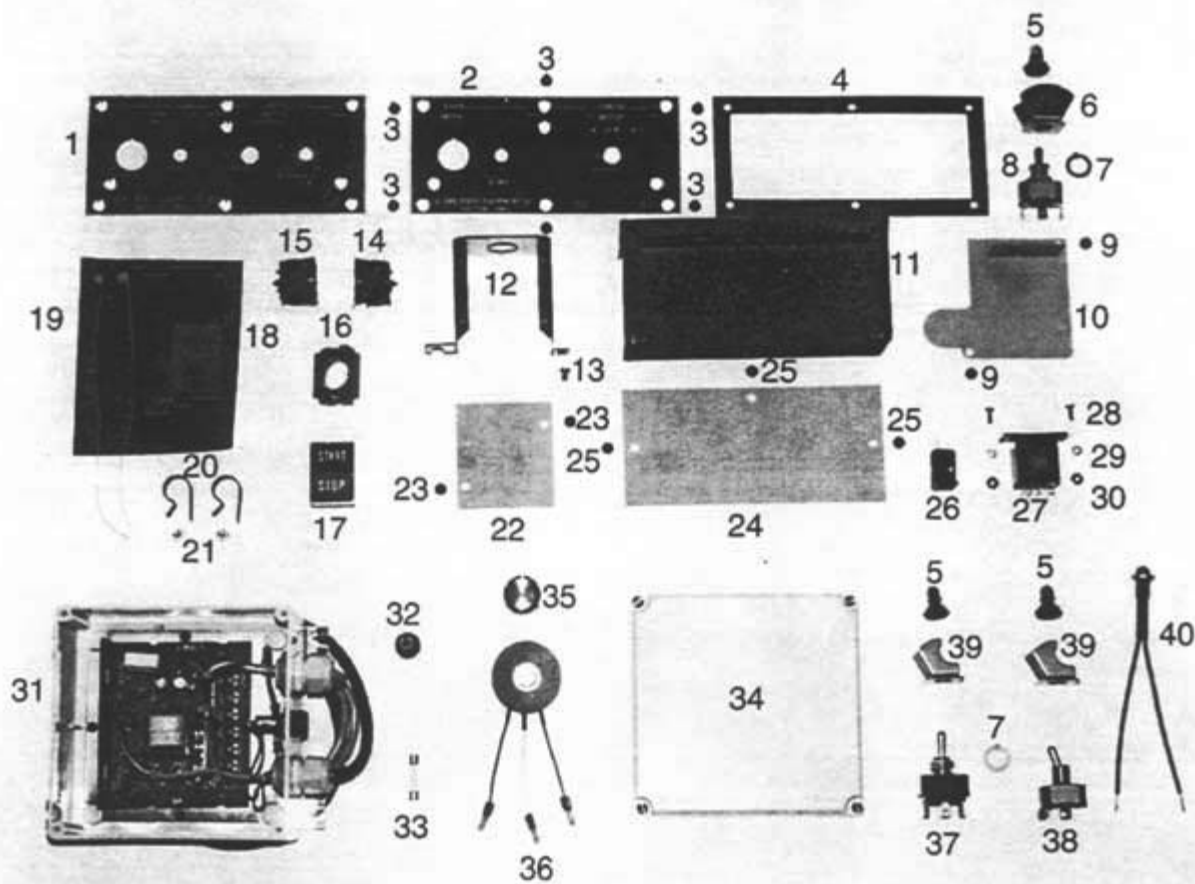

ELECTRICAL COMPONENTS AND HARDWARE

ITEM	DESCRIPTION	PART NUMBER	MODEL NUMBER				
			2500	2750	2875V	2850V	ALL
32	● FUSE CAP	763-EVC-9			X	X	
33	● FUSE	763-EVC-8			X	X	
34	● PLASTIC LID	971-6L			X	X	
35	SPEED CONTROL KNOB	763-EVC-1			X	X	
36	SPEED ADJUST POTENTIOMETER	971-1P			X	X	
37	MAIN SWITCH	952-8	X				
38	TOGGLE SWITCH	648			X	X	
39	SWITCH GUARD	785-15G					X
40	INDICATOR LIGHT 115 VAC	952-11					X
	INDICATOR LIGHT 220 VAC	952-220					X

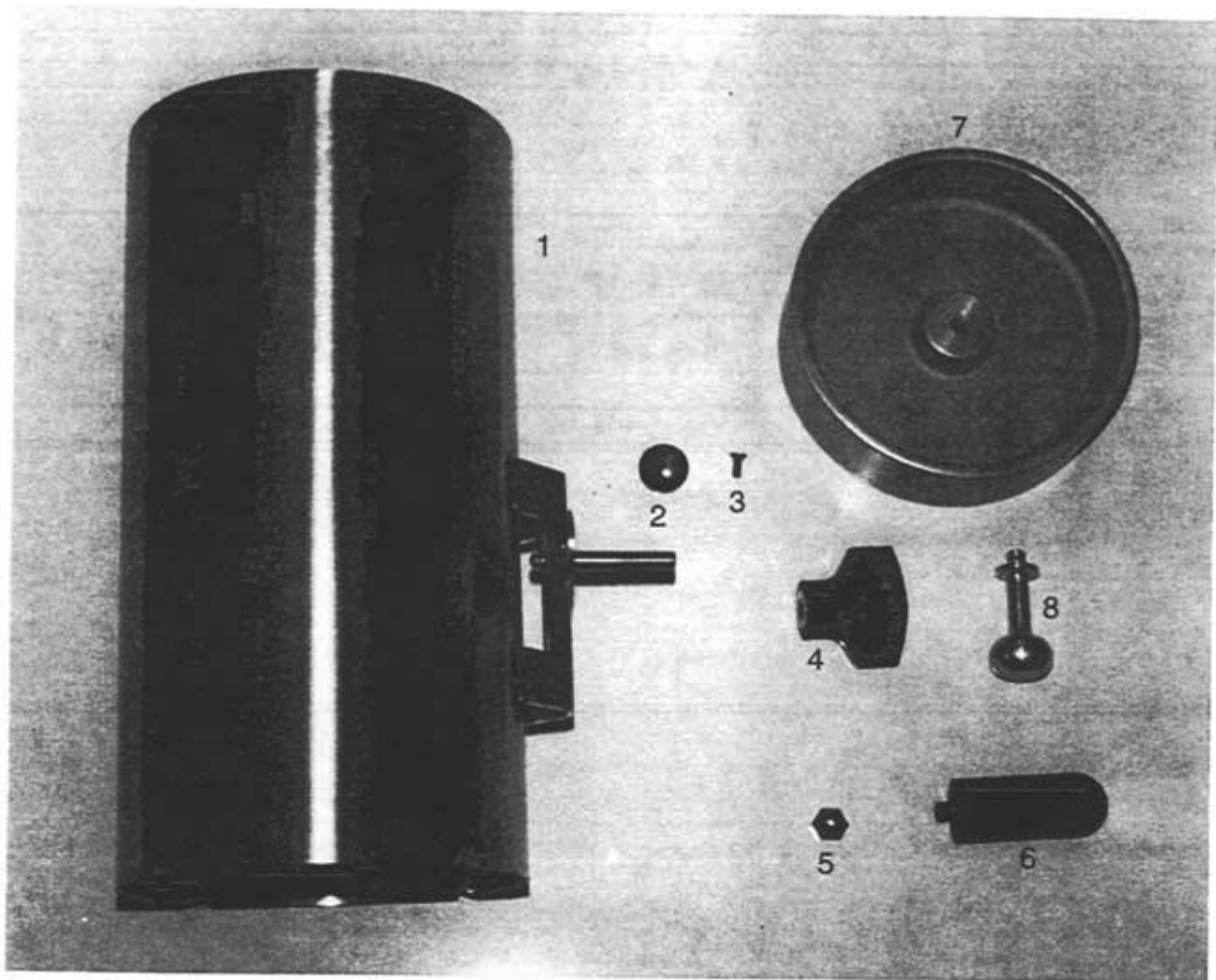

VEGETABLE HOPPER ACCESSORY

ITEM	DESCRIPTION	PART NUMBER
	VEGETABLE HOPPER ASSEMBLY	699-AS
1	● HOPPER BODY WITH SUPPORT AND STUD	699-1W
2	● HOPPER STOP CAM	699-21
3	● HOPPER CAM STOP SCREW	699-25
4	● HOPPER NUT	798-B
5	● ACORN NUT	699-32
6	● HOPPER HANDLE	482-B
	HOPPER END WEIGHT ASSEMBLY	699-16
7	● HOPPER END WEIGHT	699-17
8	● HOPPER END WEIGHT HANDLE	699-18

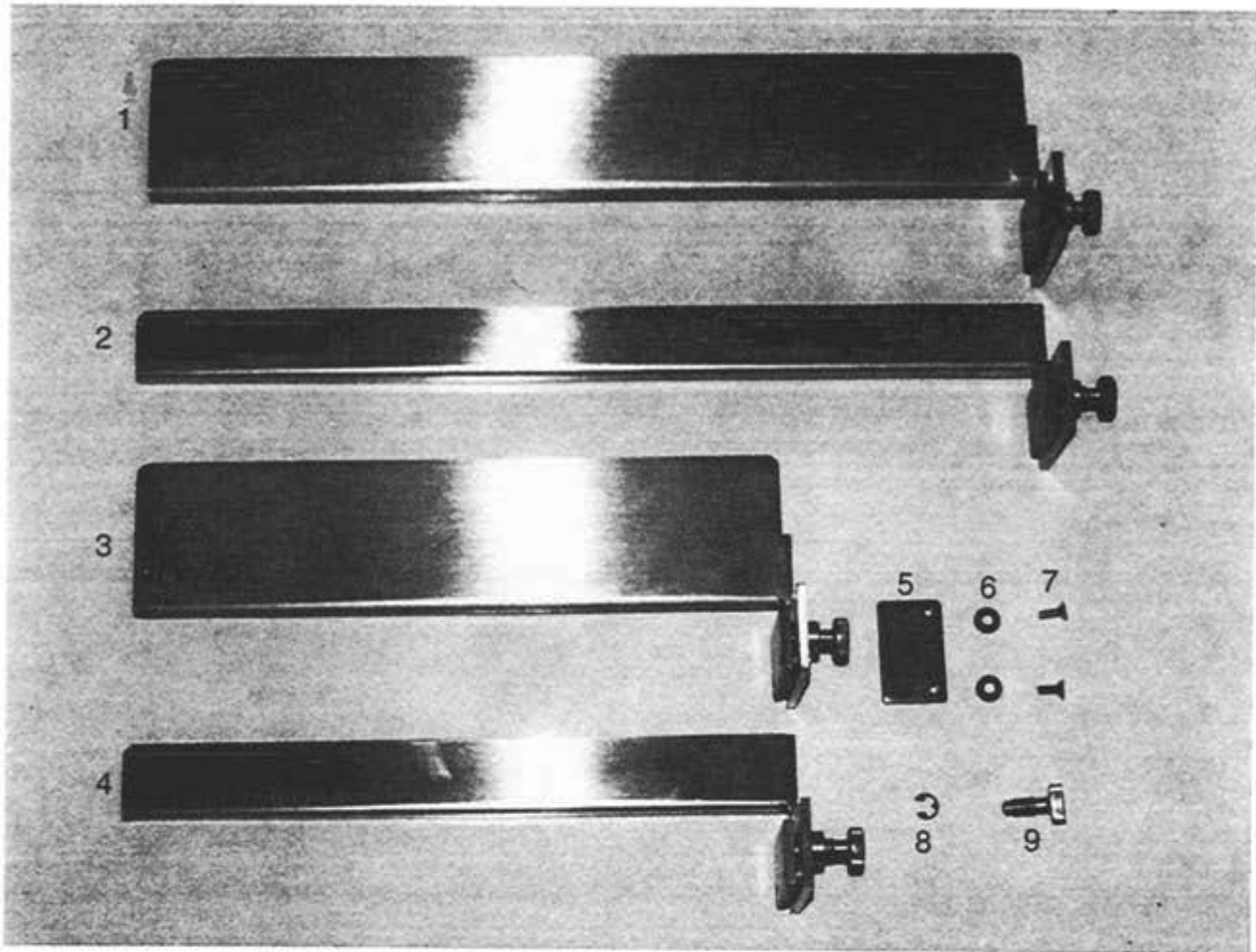

CHUTE FENCES ACCESSORY

ITEM	DESCRIPTION	PART NUMBER
	FENCE ASSEMBLY 17" X 3"	940-FLH
	FENCE ASSEMBLY 17" X 1 3/8"	940-FLL
	FENCE ASSEMBLY 12" X 3"	940-FSH
	FENCE ASSEMBLY 12" X 1 3/8"	940-FSL
1	● FENCE 17" X 3"	940-9LT
2	● FENCE 17" X 1 3/8"	940-9LL
3	● FENCE 12" X 3"	940-9ST
4	● FENCE 12" X 1 3/8"	940-9SL
5	● FENCE CLAMP	940-5
6	● CLAMP SPACER (2 REQ'D)	940-7
7	● CLAMP MOUNTING SCREW (2 REQ'D)	699-25
8	● RETAINING RING	940-10
9	● CLAMP THUMB SCREW	940-6

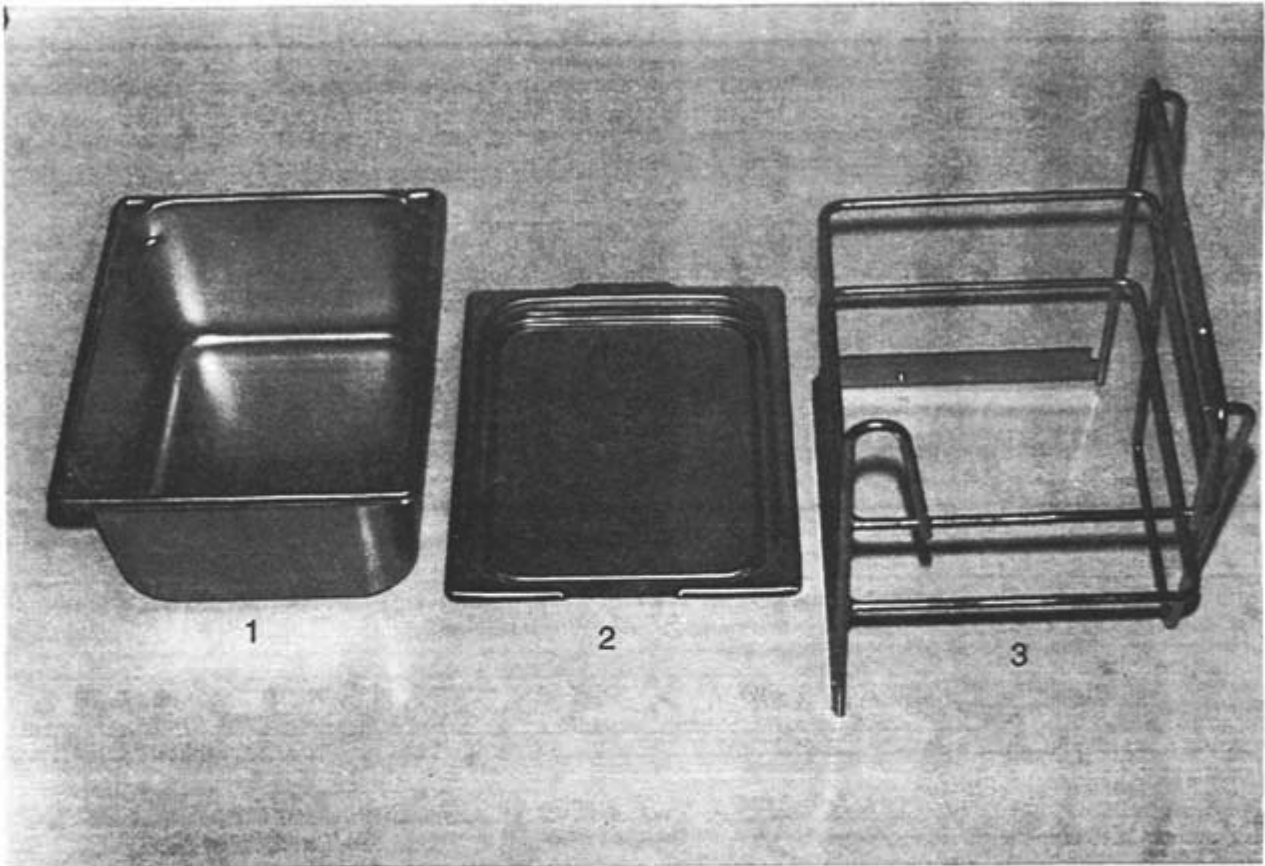

**RECEIVING PAN & LID ASSEMBLY W/ STAND ACCESSORY
MODEL 2850V**

ITEM	DESCRIPTION	PART NUMBER
	RECEIVING PAN AND LID ASSEMBLY WITH STAND	958-AS
1	● PAN	958-1
2	● TRAY / LID	958-2
3	● STAND	958

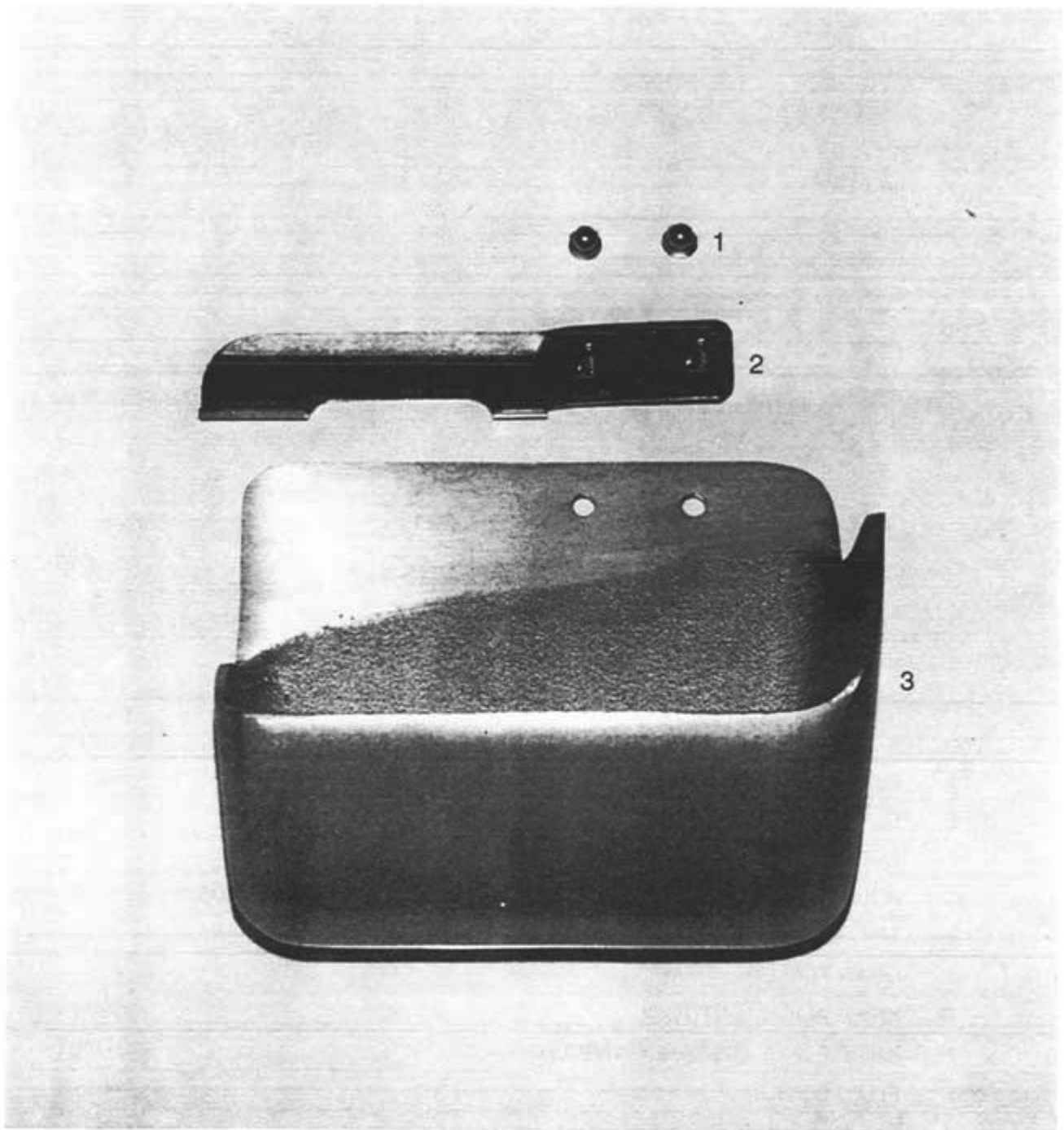

JUICE BOX ACCESSORY

ITEM	DESCRIPTION	PART NUMBER
	JUICE BOX ASSEMBLY	676-AS
1	● NUT (2 REQ'D)	676-3
2	● CLIP	676-1
3	● JUICE BOX	676

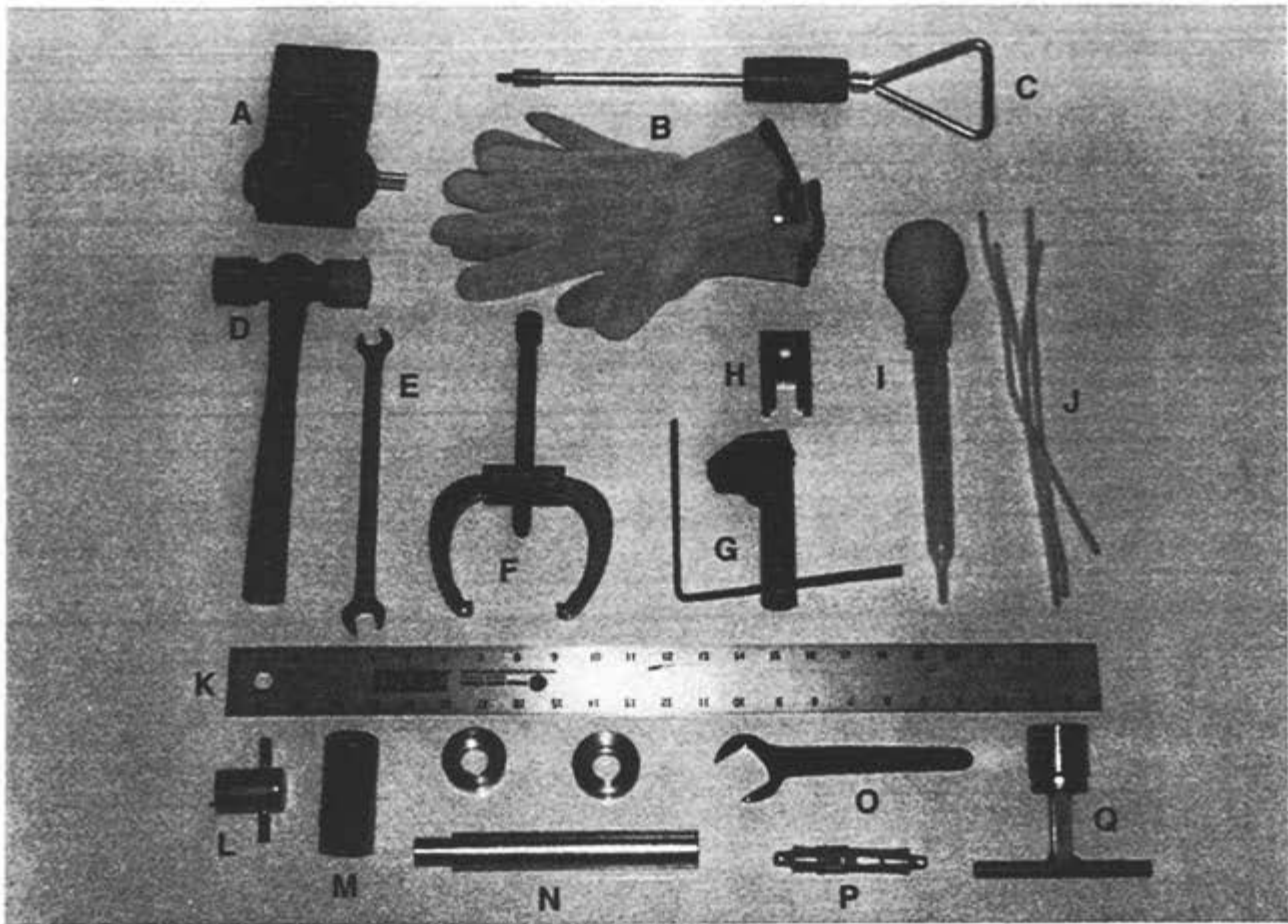

TOOL LIST

ITEM	DESCRIPTION	PART NUMBER
A	DIGITAL TEST METER	P.L.
B	CUT RESISTANT GLOVES	P.L.
C	SLIDE ROD HAMMER	P.L.
D	RUBBER / NYLON HAMMER	P.L.
E	1/2" - 9/16" THIN TAPPET WRENCH	P.L.
F	GEAR PULLER	P.L.
G	KNIFE ALIGNMENT TOOL	963-AT
H	KNIFE PLATE ASSEMBLY WRENCH	747-14ST
I	FLUID SIPHON	P.L.
J	CLEANING WIRES	P.L.
K	24" STRAIGHT EDGE	P.L.
L	SHARPENER SPRING TENSION TOOL	450-ST
M	1 1/16" DEEP WELL SOCKET	P.L.
N	BEARING TOOL	747-BT
O	1 1/4" PUMP WRENCH	P.L.
P	FUSE PULLER	P.L.
Q	1 1/4" "T" SOCKET	P.L.

*P.L. = PURCHASED LOCALLY