

# Parts Catalog



*precisely!*



**Model 4600P**

## SLICING MACHINES

MODELS:

4600P, 4975P & 4913

05-01-12

IMPORTANT!

TO EXPEDITE SHIPMENT OF PARTS, ALWAYS SPECIFY MODEL, REV,  
PART NUMBER, AND SERIAL NUMBER OF SLICER.

### **GLOBE FOOD EQUIPMENT COMPANY**

2215 East River Road  
Dayton, Ohio 45439

#### **Parts Department**

Toll Free 1-800-745-6238 · Fax (937) 290-0585

E-Mail: [globeinfo@globeslicers.com](mailto:globeinfo@globeslicers.com)

Website: [www.globeslicers.com](http://www.globeslicers.com)

Not for resale

## TABLE OF CONTENTS

SLICER ACCESSORIES	1
SLICER BASE AND GEAR HOUSING	2
BASE SHROUD AND COMPONENTS	3
KNIFE RIM GUARD, OLD STYLE SHARPENER	4
KNIFE RIM GUARD, NEW STYLE SHARPENER	5
KNIFE SHARPENER, OLD STYLE	6
KNIFE SHARPENER, NEW STYLE	7
KNIFE MOTOR BEARING ASSEMBLY	8
KNIFE MOTOR COMPONENTS	9
KNIFE AND KNIFE COVER	10
SLICER TABLE	11
TABLE ADJUSTMENT COMPONENTS	12
TABLE SLIDE COMPONENTS	13
STAINLESS STEEL CHUTE AND SUPPORT	14
END WEIGHTS	15
SLIDE SYSTEM, AUTOMATIC SLICER	16
CHUTE DRIVE SYSTEM, AUTOMATIC SLICER	17
AUTOMATIC BASE APRON AND LIFT LEVER ASSEMBLY	18
AUTOMATIC ELECTRICAL SYSTEM	19
FRONT MOUNTED END WEIGHT CHUTE ASSEMBLY	20
FRONT MOUNTED END WEIGHT ASSEMBLY	21
VEGETABLE HOPPER ACCESSORY	22
CHUTE FENCE ACCESSORIES	23
MANUAL ELECTRICAL SYSTEM	24
SCHEMATIC 4600P	25
SCHEMATIC 4975P	26
SCHEMATIC 4975P & 4913: RETROFIT KIT - 2nd GEN PCBS	27
SCHEMATIC 4975P & 4913: UPGRADE KIT - 2nd GEN PCBS	28
SCHEMATIC 4975P & 4913 - 2nd GEN CIRCUIT BOARDS	29
SCHEMATIC 4975P & 4913 - 2nd GEN w/o PWR SUPPLY	30

# ACCESSORIES

VEGETABLE HOPPER 699-BAS

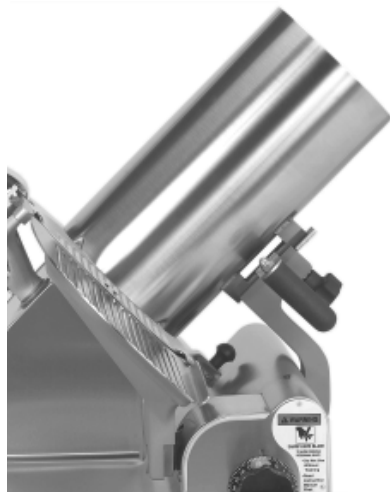

ADJUSTABLE STAINLESS STEEL FENCES  
TALL 1326      SHORT 1047

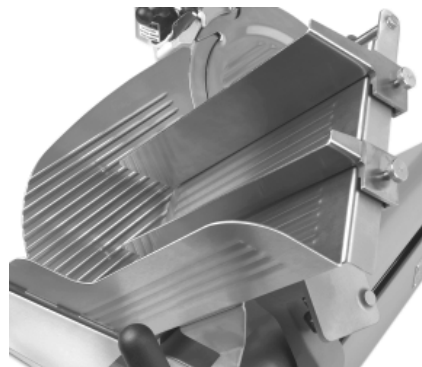

FRONT MOUNTED END WEIGHT 102-AS-21

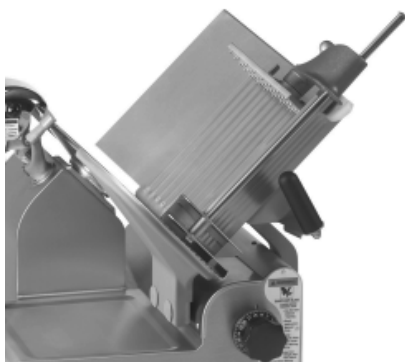

PORTION SCALE PS13



EXTENSION LEGS 873



ACCESSORIES: MODEL 4913 ONLY

ITEM	PART DESCRIPTION	PART NUMBER	QTY
1	FOOT RETAINING KIT	530001	1
2	CLEANING BRUSH, SS STONES	980020	1
3	CLEANING BRUSH	980041	1

# 4000P SLICER BASE AND GEAR HOUSING

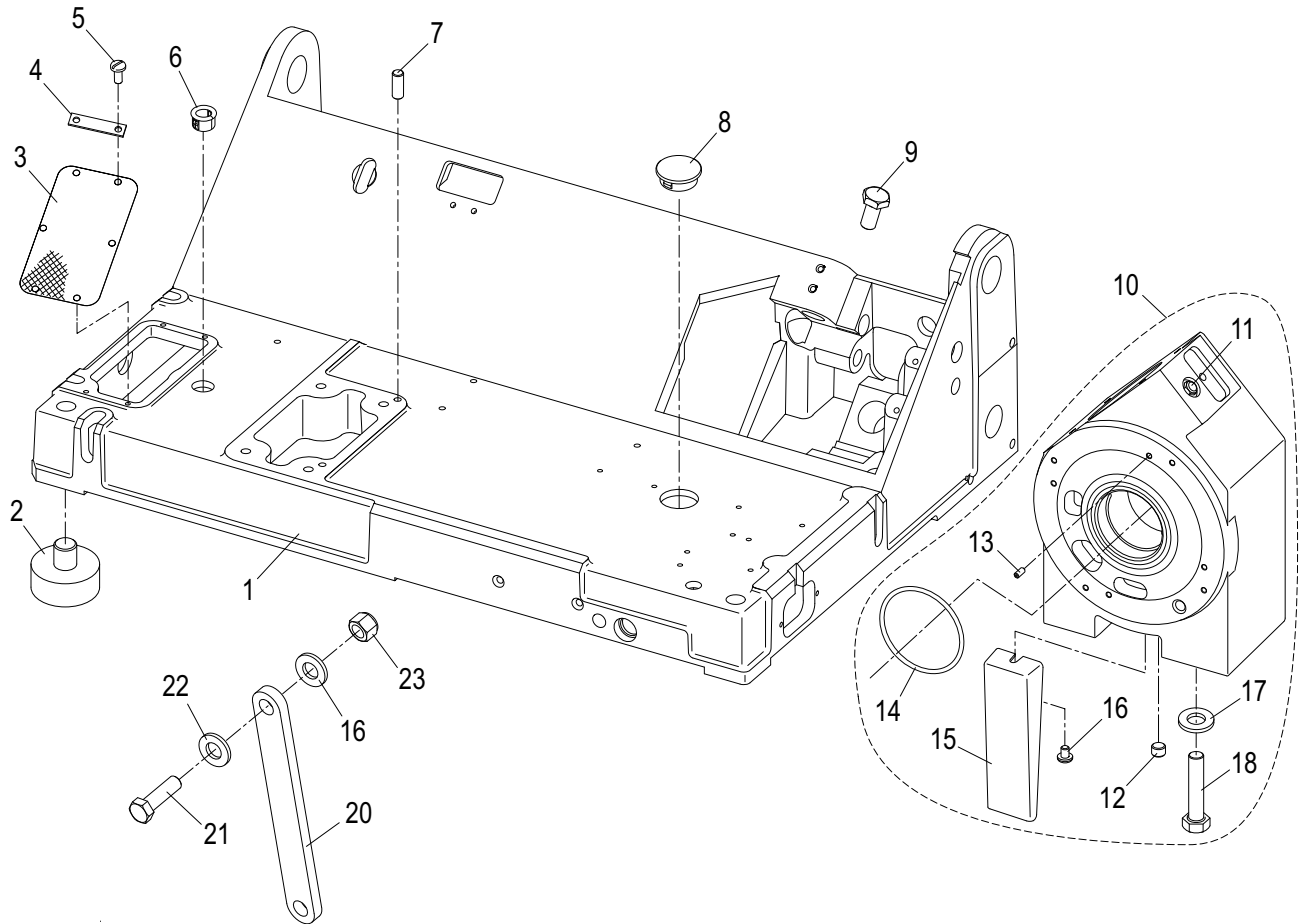

ITEM	PART DESCRIPTION	PART NUMBER	QUANTITY	
			MAN	AUTO
1	BASE, MANUAL	1385	1	-
	BASE, AUTOMATIC	1386	-	1
2	SLICER FOOT	817-S	4	
3	MOTOR SCREEN	1148	1	
4	MOTOR SCREEEN BRACE	1255	2	
5	SCREW, MOTOR SCREEN	1227	4	
6	SPLIT BUSHING	550002	3	
7	DOWEL PIN	1091	2	
8	HOLE PLUG	1208	1	
9	SCREW, GAUGE PLATE SLIDE ROD	975-1	1	
10	GEAR HOUSING	070051	1	
*11	VENT PLUG (INCLUDED W/GEAR HOUSING)	-	1	
12	DRAIN PLUG	890082	1	
*13	SET SCREW	700-3	1	
*14	O-RING	840001	1	
*15	OIL DRAIN CHUTE	520100	1	
*16	DRAIN CHUTE MOUNTING SCREW	810305	1	
17	FLAT WASHER	763-4A	4	
18	HEX BOLT	369-1	4	
*19	GEARBOX OIL, 6.5 OZ BOTTLE (NOT SHOWN)	920000		1
20	CLEANING BRACE	873-CB	1	-
21	BOLT, HEX HEAD	477	1	-
22	FLAT WASHER	763-4A	2	-
23	NUT, NYLON INSERT	873-CB-1	1	-

\*USED ONLY ON OIL BATH & SERRATED KNIFE UNITS.

# 4000P BASE SHROUD AND COMPONENTS

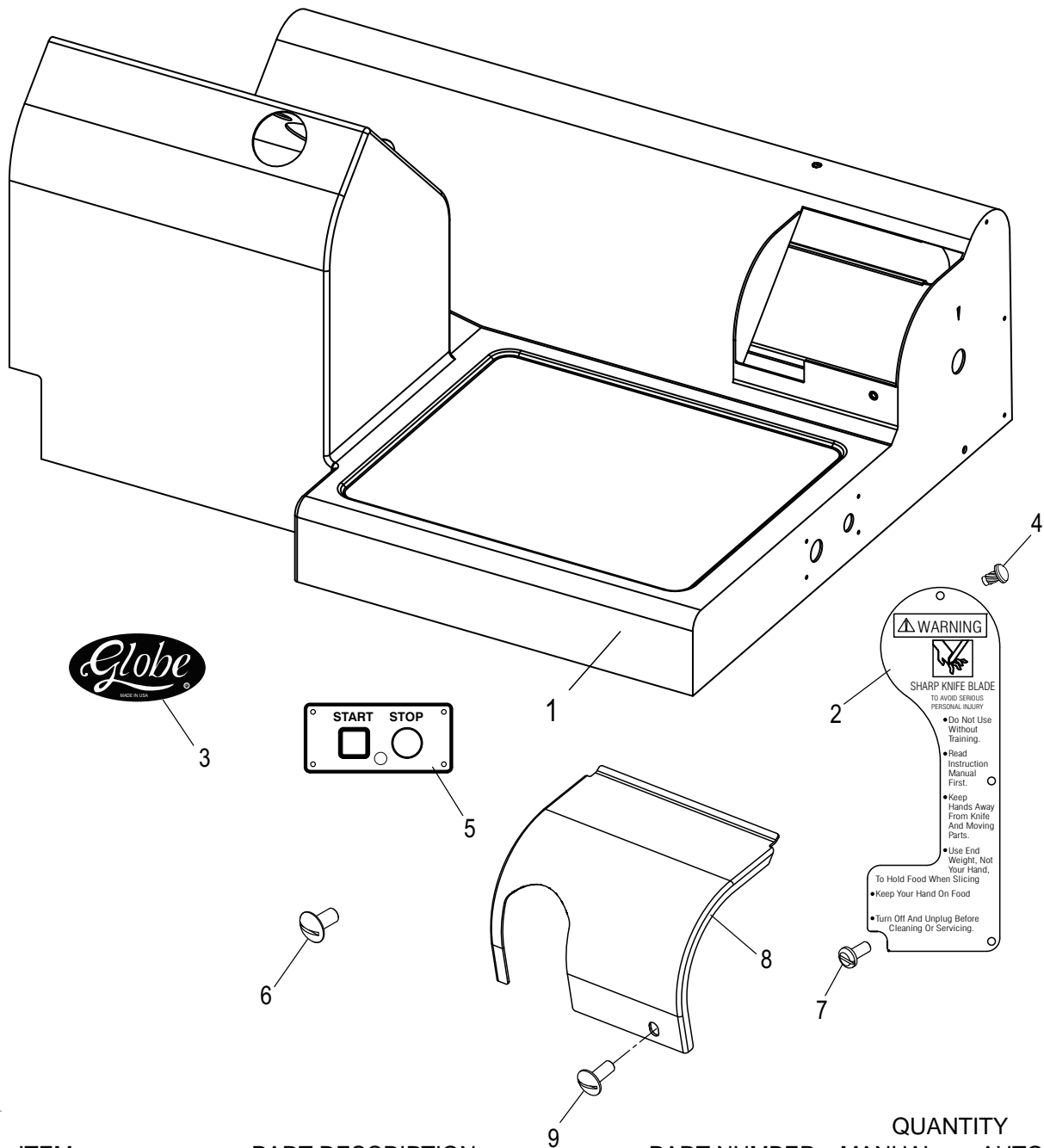

ITEM	PART DESCRIPTION	PART NUMBER	QUANTITY	
			MANUAL	AUTO
1	BASE SHROUD, MANUAL	310121	1	-
	BASE SHROUD, AUTOMATIC	*310123	-	1
2	WARNING DECAL - ENGLISH	967-1	1	1
	WARNING DECAL - SPANISH	967-1S	1	1
	WARNING DECAL - FRENCH	967-1F	1	1
3	GLOBE LOGO DECAL	871-2	1	1
4	DRIVE SCREW	851-6P	7	3
5	SWITCH COVER	1157	1	-
6	SCREW	762-6	1	1
7	SCREW	1227	1	1
8	TABLE MECHANISM COVER	310125	1	1
9	SCREW	900-1	1	1
10	HOLE PLUG, EZ GLIDE MODEL (NOT SHOWN)	890200	1	-

\* AUTOMATIC BASE SHROUD NOT SHOWN.

# 4000P KNIFE RIM GUARD, OLD STYLE SHARPENER

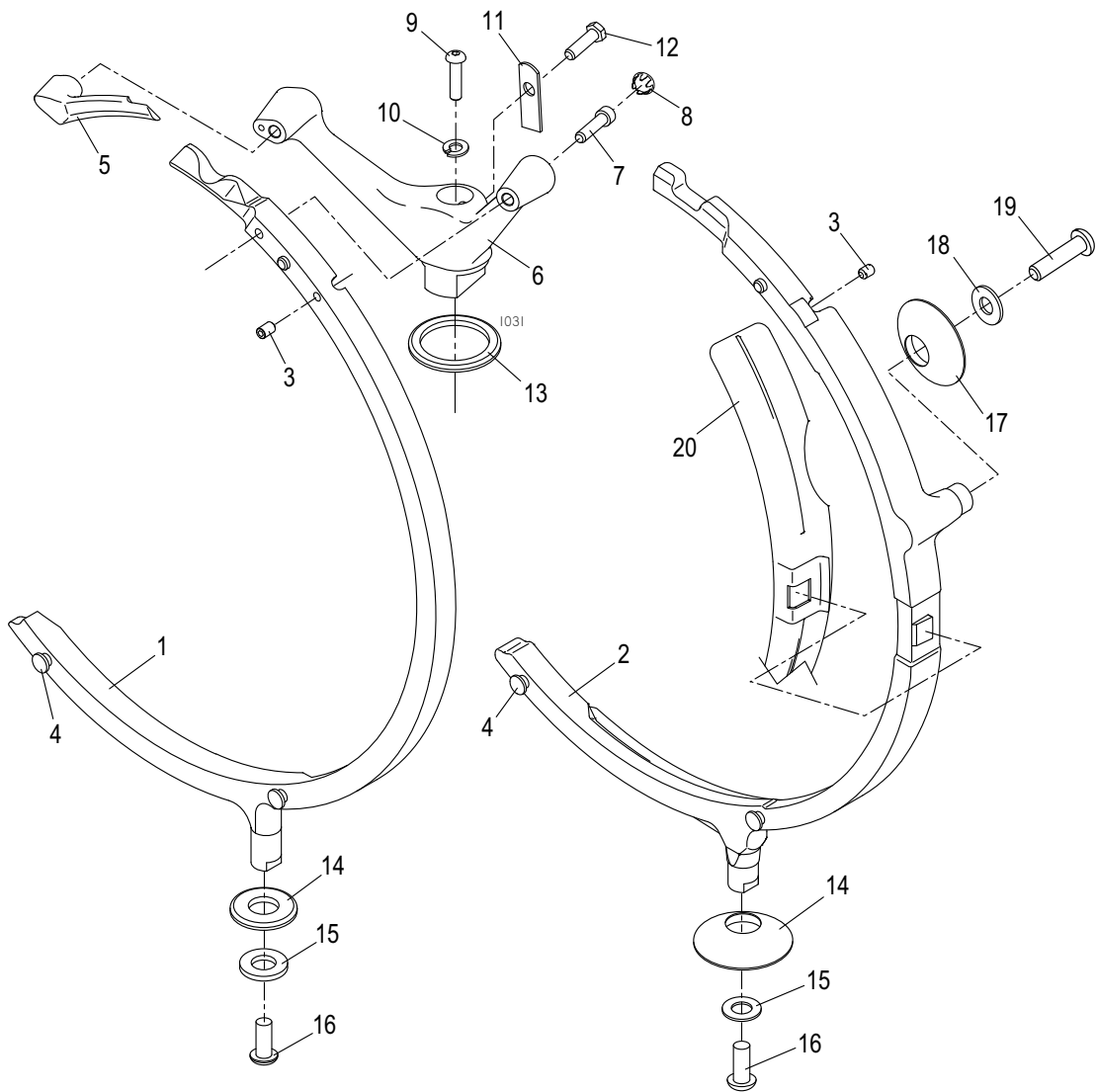

ITEM	PART DESCRIPTION	PART NUMBER		QTY
1	KNIFE RIM GUARD ASSEMBLY	070053	-	1
2	KNIFE RIM GUARD ASSY MOLDED	-	520282	1
3	SET SCREW	1245	810382	1
4	LOCATOR PIN	1131		2
5	UPPER KNIFE RIM GUARD	070063		1
6	KNIFE RIM GUARD BRACKET	230000		1
7	SCREW, SOCKET HEAD	1238		2
8	HOLE PLUG	1211		2
9	SCREW, BUTTON HEAD	1217		1
10	LOCKWASHER	1226		1
11	HOLE COVER	320010		1
12	BOLT, HEX HEAD	810050		1
13	TRIM RING	1031		1
14	TRIM RING/LOWER BOOT	1032	520220	1
15	WASHER	763-4A	229	1
16	SCREW, BUTTON HEAD	1239		1
17	UPPER BOOT	-	520220	1
18	FLAT WASHER	-	825-2	1
19	SCREW, BUTTON HEAD	-	1217	1
20	PRODUCT RETAINER	-	520219	1

# 4000P KNIFE RIM GUARD, NEW STYLE SHARPENER

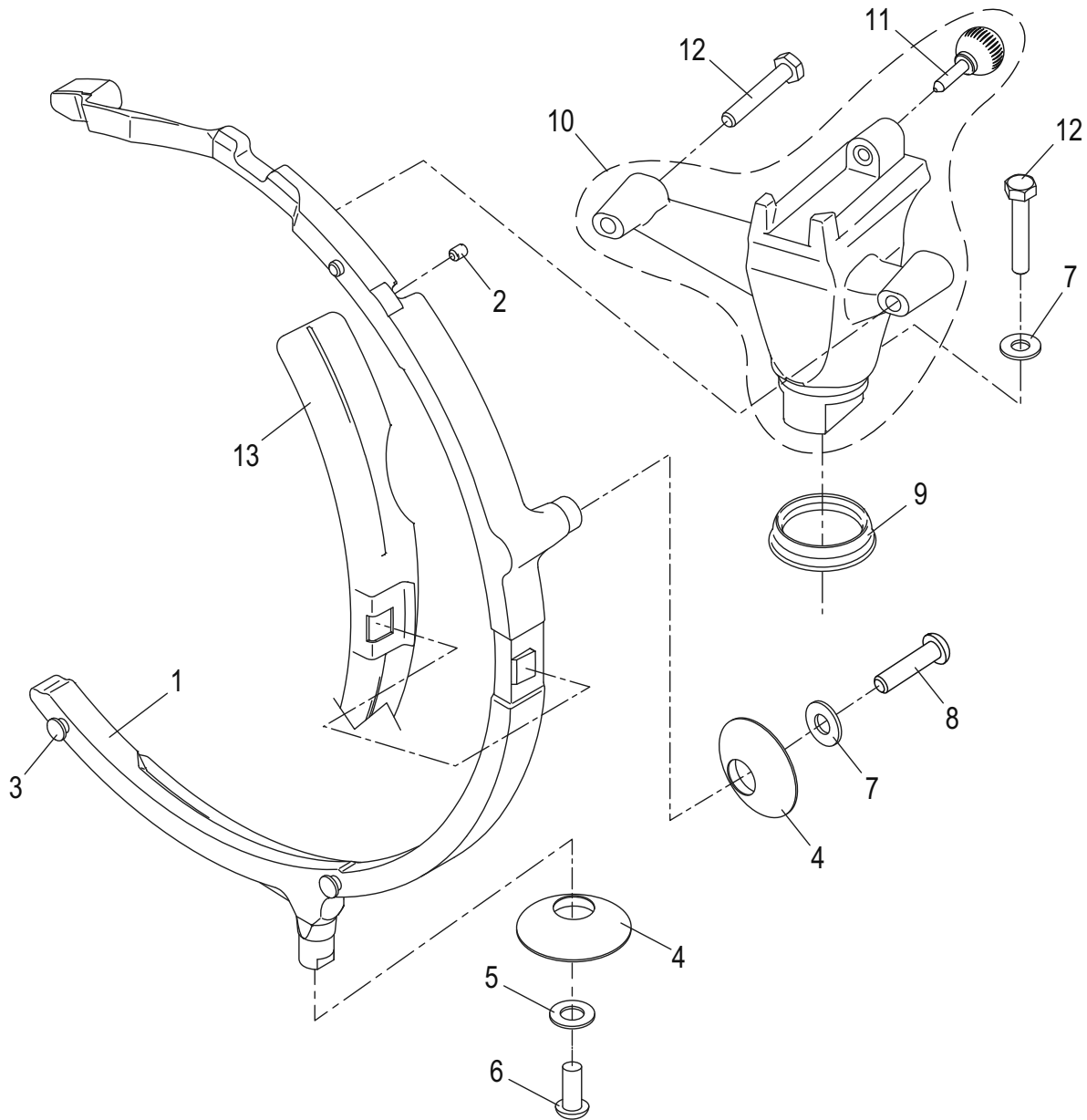

ITEM	PART DESCRIPTION	PART NUMBER	QTY
*1	KNIFE RIM GUARD ASSY MOLDED	520250	1
2	SET SCREW	810382	1
3	LOCATOR PIN	1131	2
4	MOUNTING BOOT	520220	2
5	FLAT WASHER	229	1
6	SCREW, BUTTON HEAD	1239	1
7	FLAT WASHER	825-2	2
8	SCREW, BUTTON HEAD	1217	1
9	SHARPENER BRACKET BOOT	520221	1
10	RIM GUARD/SHARPENER BRACKET	520261	1
11	SHARPENER KNOB	520330	1
12	SCREW, HEX HEAD	890460	3
13	PRODUCT RETAINER	520219	1

\*STARTING S/Ns = 4600P: 4600400, 4975P: 4975600.

# 4000P KNIFE SHARPENER ASSEMBLY, OLD STYLE

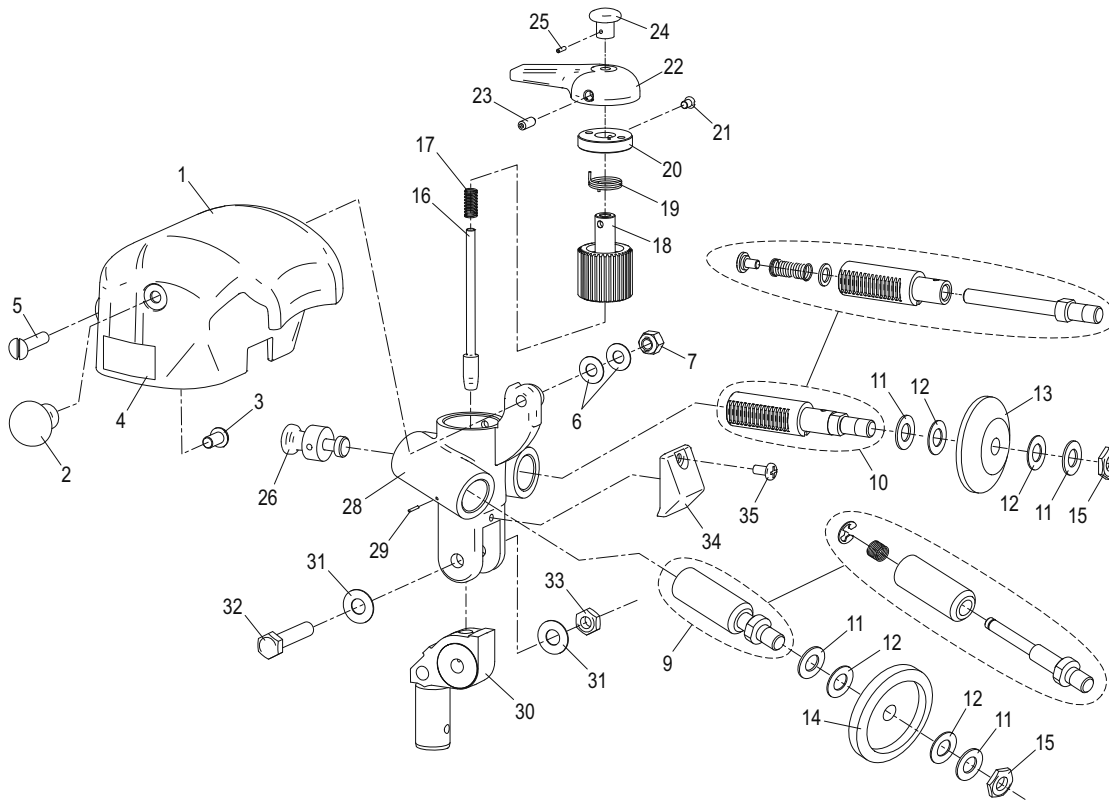

ITEM	PART DESCRIPTION	PART NUMBER	QTY
	SHARPENER ASSY WITH COVER (4913 USE 070046)	070040	1
1	SHARPENER COVER	1041	1
2	SHARPENER COVER KNOB (4913 USE 510002)	1138	1
3	SHARPENER COVER COVER KNOB SCREW	1258	1
4	COVER WARNING DECAL - ENGLISH	967-2	1
	COVER WARNING DECAL - SPANISH	967-2S	1
5	COVER HINGE SCREW	825-1	1
6	COVER TENSION WASHER	761-6	2
7	COVER HINGE NUT	810266	1
8	SHARPENER ASSY W/O COVER (4913 USE 070045)	070041	1
9	GRINDING SHAFT ASSEMBLY	463-AS	1
10	TRUING SHAFT ASSEMBLY	467-AS	1
11	WASHER	229	5
12	WASHER, FIBER	229-1	4
13	TRUING STONE (4913 USE 240033)	213	1
14	GRINDING STONE (4913 USE 240032)	214-A	1
15	NUT, GROUND	810140	1
16	LOCK ROD ASSEMBLY	456-AS	1
17	LOCK SPRING	458	1
18	GEAR	455	1
19	GEAR RETURN SPRING	460	1
20	GEAR SPACER RING	459	1
21	SET SCREW	470-1	2
22	HANDLE	495	1
23	SET SCREW	495-1	1
24	LOCK KNOB	461	1
25	LOCK KNOB PIN	287-2	1
26	TRUING STONE STOP ASSEMBLY	471-AS	1
27	SHARPENER SUBASSEMBLY	-	1
28	HOUSING	450-H	1
29	SLEEVE PIN	300	1
30	BRACKET	240020	1
31	WASHER	286-1	2
32	HINGE BOLT	475	1
33	NUT	286	1
34	HOLE COVER	520060	1
35	SCREW	810280	1



# 4000P SHARPENER ASSEMBLY, NEW STYLE

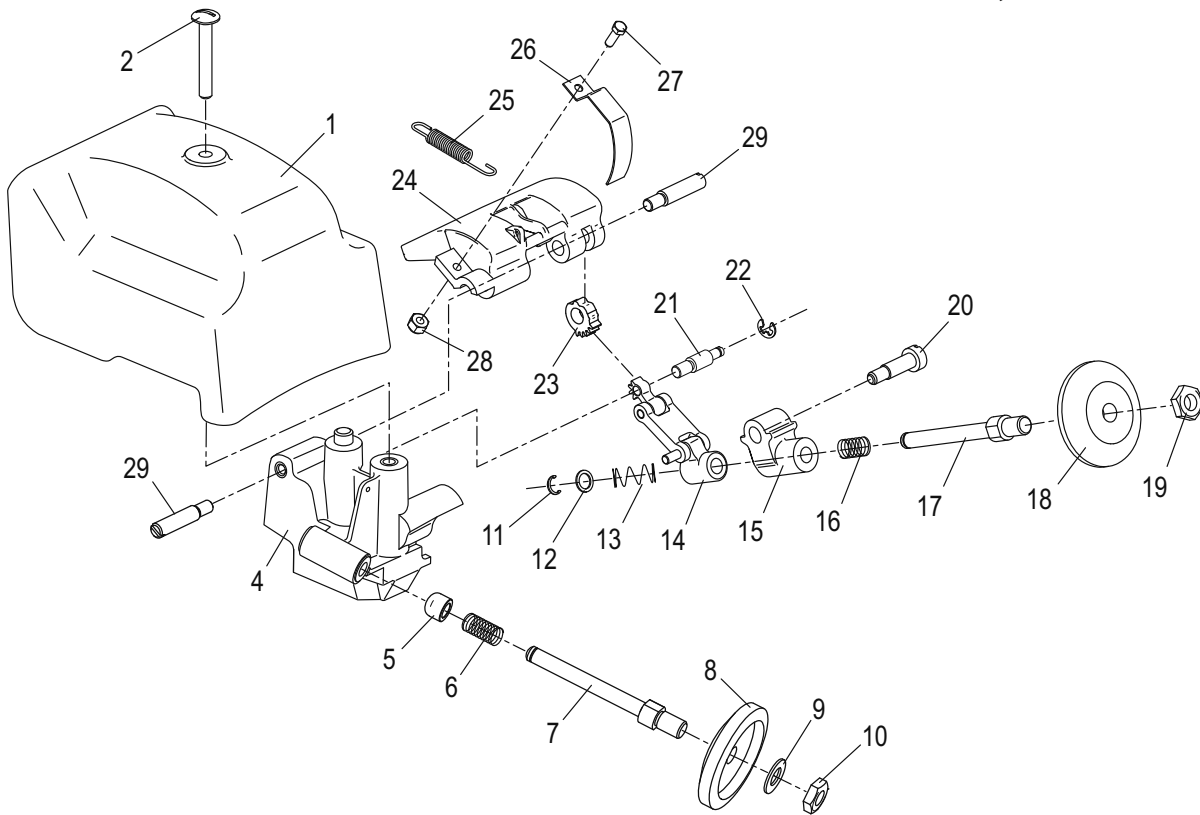

ITEM	PART DESCRIPTION	PART NUMBER	QTY
	SHARPENER ASSY WITH COVER	520240-01	1
1	SHARPENER COVER	520222	1
2	SHARPENER COVER SCREW	890340	1
3	SHARPENER ASSY W/O COVER		1
4	SHARPENER HOUSING	520223	1
5	END CAP, GRINDING WHEEL SHAFT	520310	1
6	SPRING	890300	1
7	SHAFT, GRINDING WHEEL	460037	1
8	GRINDING WHEEL (OUTSIDE)	214-A	1
9	FLAT WASHER	229	1
10	JAM NUT	890390	1
11	CRESCENT RING	890420	1
12	FLAT WASHER	890430	1
13	SPRING	890450	1
14	SHARPENER LINKAGE ASSY	520280	1
15	PIVOT, TRUING WHEEL SHAFT	520229	1
16	SPRING	890290	1
17	SHAFT, TRUING WHEEL	460037	1
18	TRUING WHEEL (INSIDE)	213	1
19	JAM NUT	890390	1
20	SHOULDER BOLT	890270	1
21	SHAFT PIVOT	460038	1
22	RETAINING RING (E-CLIP)	890490	1
23	GEAR, PIVOT DRIVE	520224	1
24	SHARPENER HANDLE	520226	1
25	SPRING, SHARPENER HANDLE	890350	1
26	ACTUATING SPRING	330123	1
27	HEX HEAD SCREW	890370	1
28	NUT, NYLOC	890380	1
29	SHARPENER HANDLE PIVOT	460039	2

STARTING S/Ns = 4600P: 4600400, 4975P: 4975600.

# 4000P KNIFE MOTOR BEARING ASSEMBLY

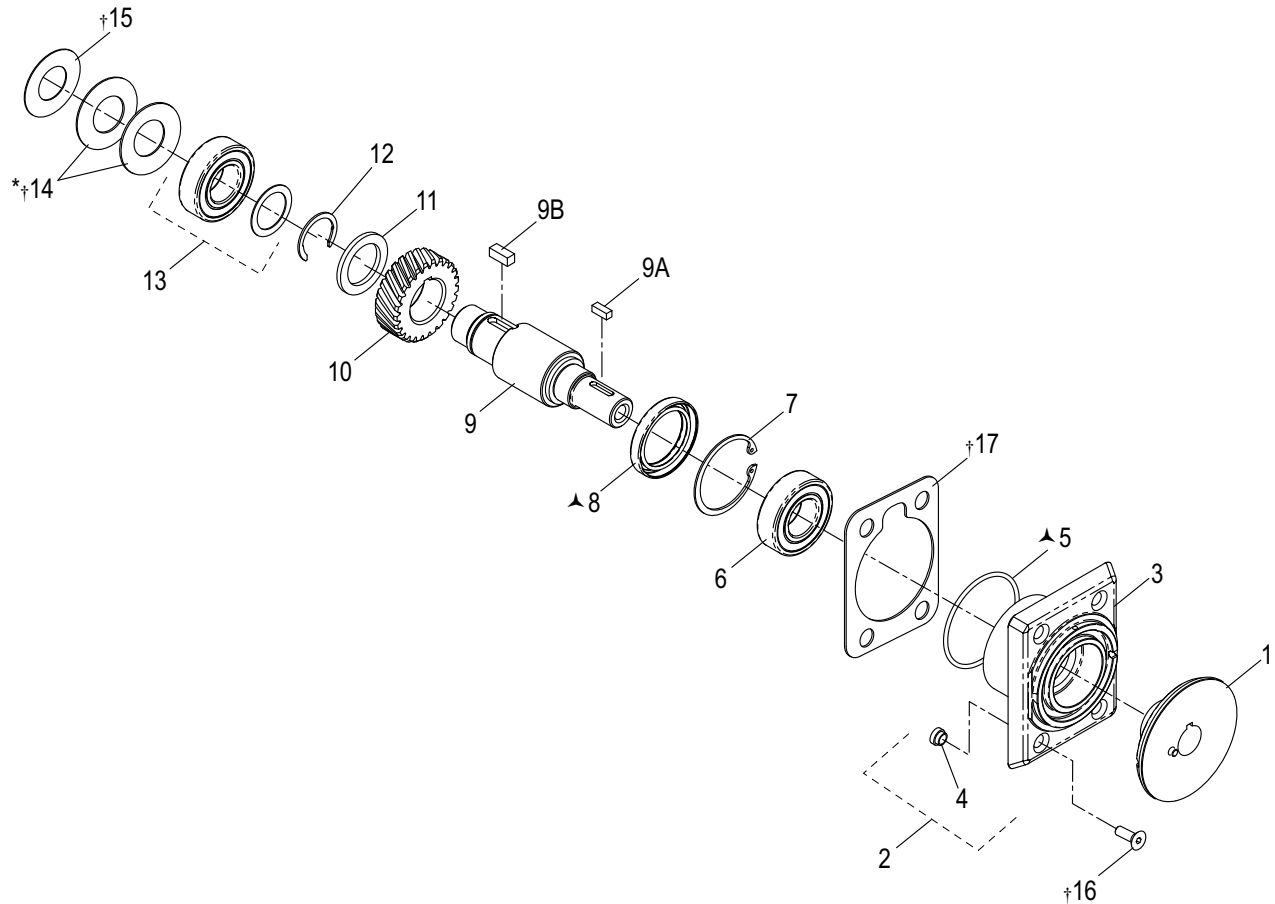

ITEM	PART DESCRIPTION	PART NUMBER	QTY
	BEARING ASSEMBLY	070049	1
	BEARING ASSEMBLY, SERRATED KNIFE PKG	070065	
1	KNIFE LOCATING HUB ASSEMBLY	070064	1
2	UPPER BEARING RETAINER ASSEMBLY	070050	1
3	UPPER BEARING RETAINER	230010	1
4	STANDOFF	1237	4
▲5	O-RING	840020	1
6	BEARING, SEALED	820045	1
7	RETAINING RING	1088	1
▲8	SHAFT SEAL	840010	1
9	KNIFE SHAFT	420080	1
9A	KEY	1106	1
9B	KEY	1086	1
10	GEAR, NYLON	1084	1
	▲GEAR, BRONZE, SERRATED KNIFE PKG	410030	
11	SPACER	1083	1
12	RETAINING RING	1087	1
13	BEARING AND SPACER	800000	1
*†14	BOWED WASHER	830010	2
†15	THRUST WASHER	820042	1
†16	SCREW, FLAT HEAD	1089	4
†17	RETAINER, SHROUD GASKET	1241	1
18	GEAR LUBRICANT (5.3 oz. TUBE) (NOT SHOWN)	521-D	1

\* NOTE OPPOSING CONFIGURATION: CONVEX SIDES OF WASHERS MUST TOUCH.

† ITEM NOT INCLUDED WITH 070049.

▲ ITEM USED ON SERRATED KNIFE PACKAGE ONLY.

# 4000P KNIFE MOTOR COMPONENTS

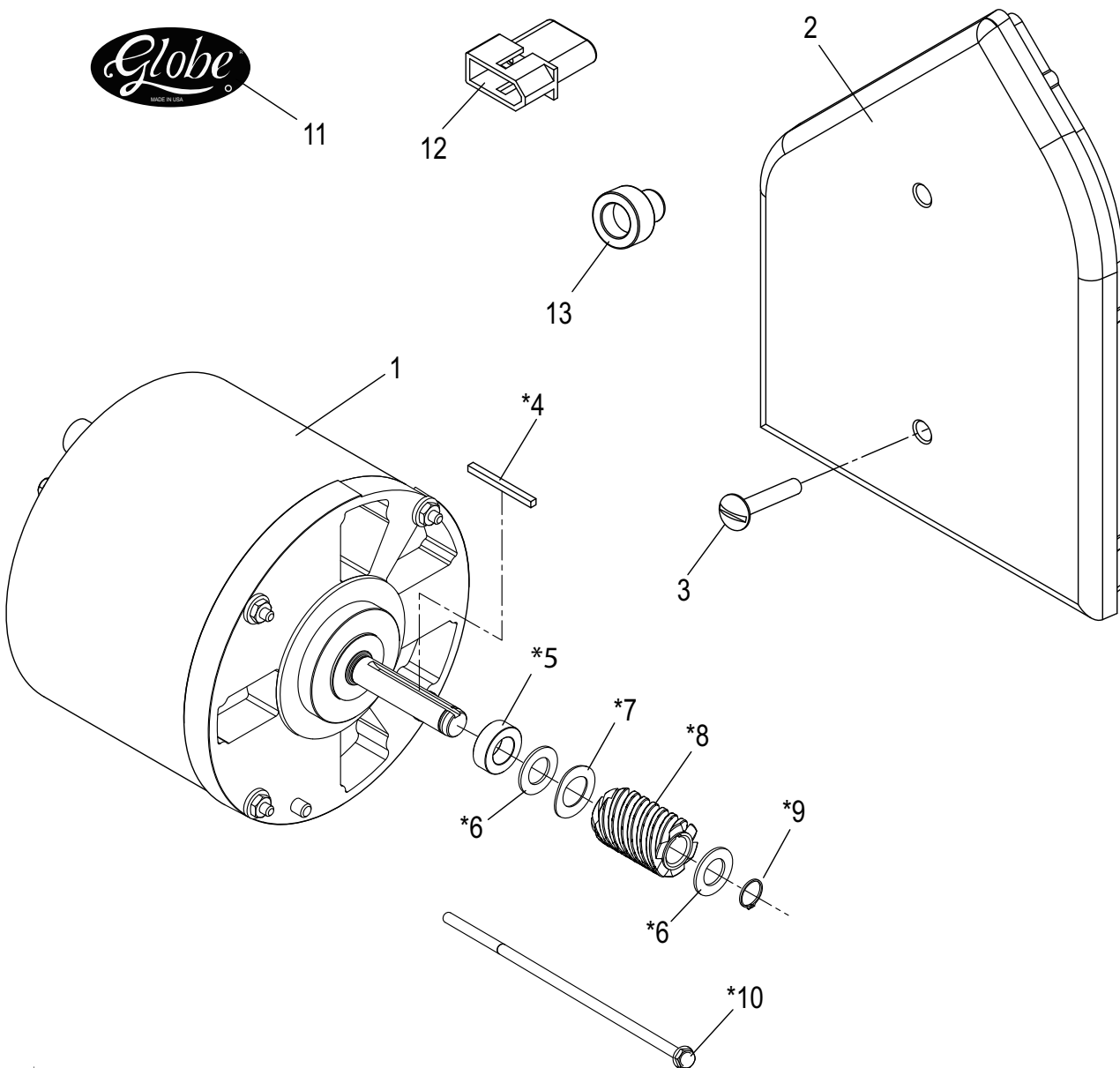

ITEM	DESCRIPTION	PART NUMBER	QTY
1	MOTOR ASSEMBLY 115VAC/60HZ/1PH	110040	1
	MOTOR ASSEMBLY 115VAC/60HZ/1PH W/RESET	110041	1
2	MOTOR COVER	520010	1
	MOTOR COVER W/RESET HOLE	†520011	1
3	SCREW	810300	2
*4	KEY, SQUARE	1372	1
*5	SPACER	460025	1
*6	FLAT WASHER	870070	2
*7	BOWED WASHER	810	1
*8	WORM GEAR	1059	1
*9	SNAP RING	880051	1
*10	MOTOR SCREW	810330	4
11	LABEL, GLOBE LOGO	871-2	1
12	WIRE CONNECTOR	1257	1
13	MOTOR RESET BUTTON EXTENSION	†530015	1

\* PARTS INCLUDED WITH ITEM 1.

† ONLY USED ON UNITS WITH MOTOR RESET OPTION.

# 4000P KNIFE AND KNIFE COVER COVER

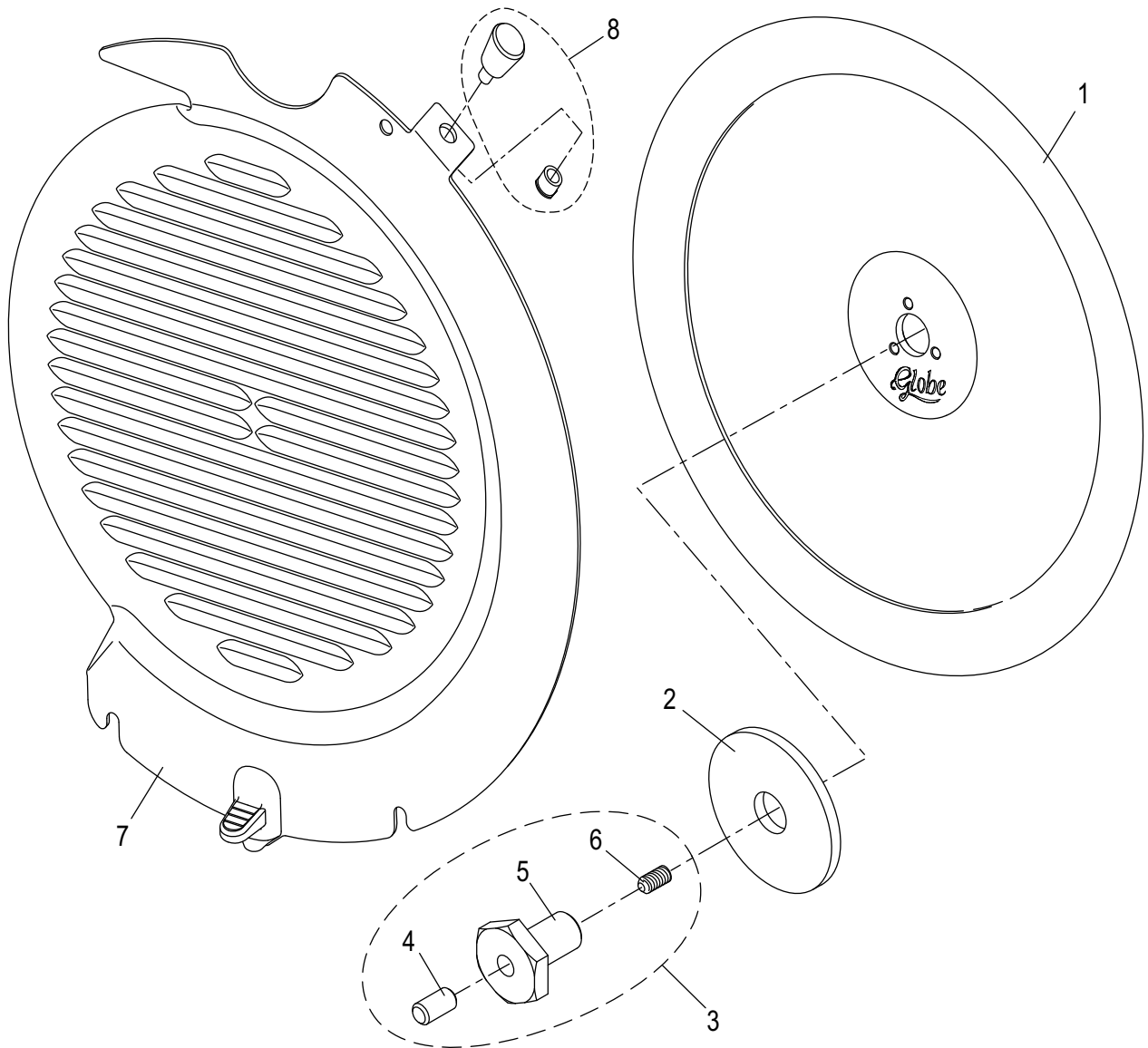

ITEM	PART DESCRIPTION	PART NUMBER	QTY
1	CARBON KNIFE	460026	1
	STAINLESS STEEL KNIFE	460027	
	CARBON KNIFE, PRESHARPENED	*460031	
2	FLAT WASHER	1092	1
3	KNIFE BOLT ASSEMBLY	800001	1
4	PLUG	1193	1
5	BOLT	1093	1
6	SET SCREW	1194	1
7	KNIFE COVER ASSEMBLY	310110	1
8	COVER KNOB	1056	1

\*USED ONLY ON MODEL 4913.

# 4000P SLICER TABLE

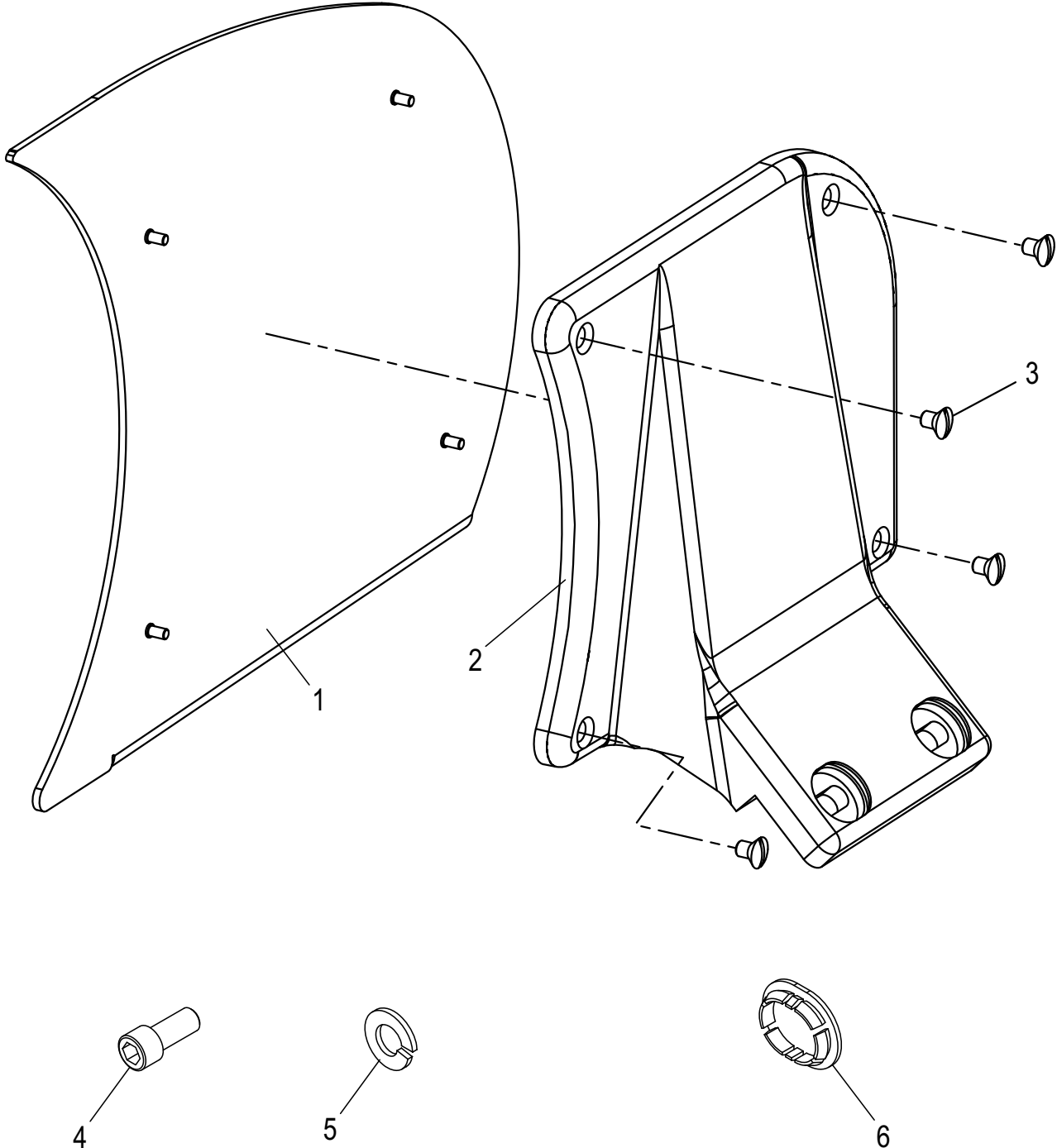

ITEM	PART DESCRIPTION	PART NUMBER	QTY
	TABLE ASSEMBLY	070054	1
1	TABLE, STAINLESS STEEL	310100	1
2	TABLE SUPPORT	1057	1
3	TABLE FASTENER	976-1	4
4	TABLE SCREW	1058	2
5	LOCK WASHER	870020	2
6	HOLE PLUG, OVAL	520000	2
7	TABLE SHIMS (NOT SHOWN)	337-A	AS REQUIRED

# 4000P TABLE ADJUSTMENT COMPONENTS

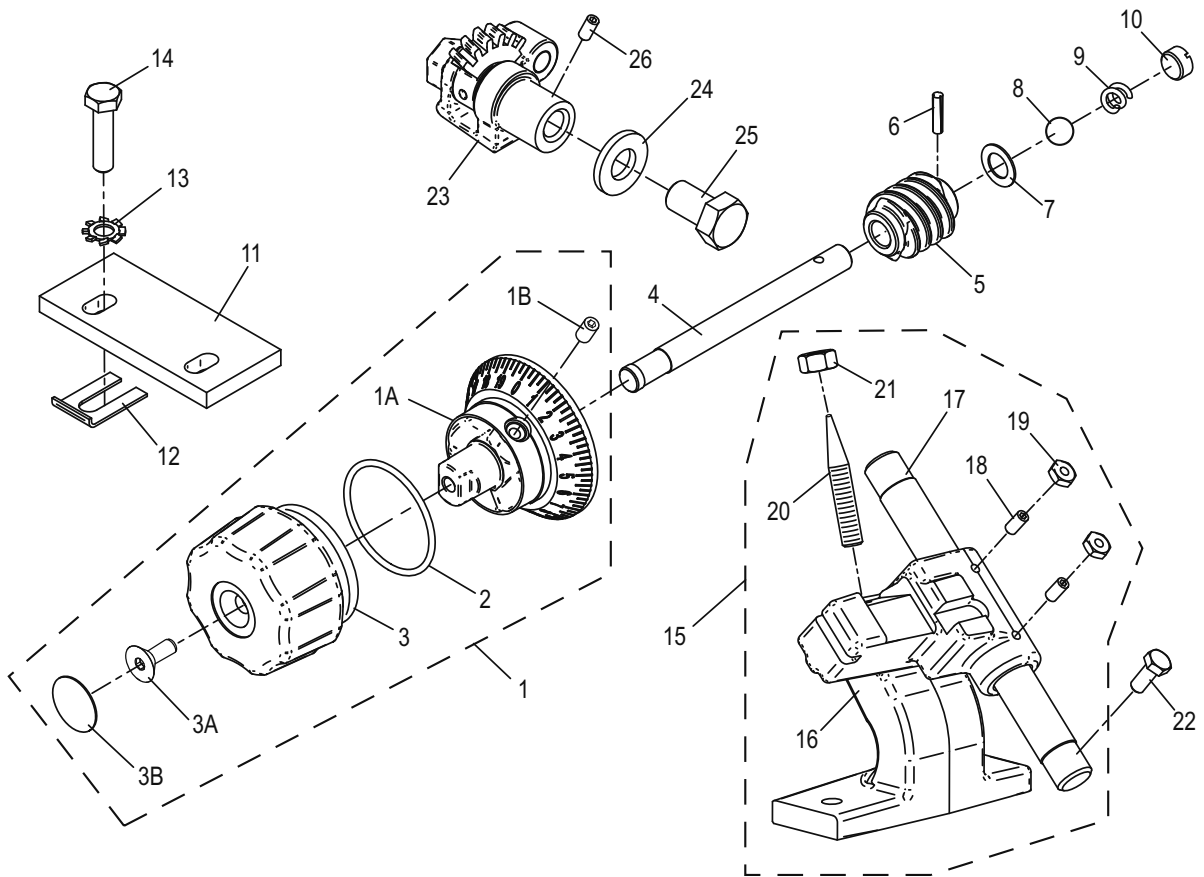

ITEM	DESCRIPTION	PART NUMBER	QTY
1	TABLE ADJUSTMENT KNOB	510020	1
1A	KNOB DIAL	510023	1
1B	SET SCREW	810320	3
2	O-RING	840025	1
3	KNOB CAP	510021	1
3A	SCREW, FLAT HEAD	810325	1
3B	SCREW COVER	910175	1
4	TABLE ADJUSTMENT KNOB SHAFT	864	1
5	WORM GEAR	1147	1
6	PIN, WORM GEAR	360	1
7	WASHER, WORM GEAR	359	1
8	BALL	362	1
9	SPRING, TENSION	1200	1
10	THRUST SCREW	361-1	1
11	SLIDE GUIDE	1259	1
12	SLIDE GUIDE SHIM (VARIOUS THICKNESS)	349-A.001 - 349-A.052	AS REQD
13	LOCK WASHER	870000	2
14	SCREW, HEX HEAD	1307	2
15	TABLE SLIDE ASSEMBLY	200052	1
16	TABLE SLIDE	260010	1
17	TABLE SLIDE SHAFT	1027	1
18	SET SCREW	168-1	2
19	NUT	760-5	2
20	STOP SCREW	430000	1
21	STOP SCREW NUT	478-1	1
22	SCREW, HEX HEAD	975-1	1
23	TABLE ADJUSTING GEAR ASSEMBLY	453-AS	1
24	FLAT WASHER	881-4	1
25	HEX SCREW	335	1
26	SET SCREW	700-3	2

# 4000P TABLE SLIDE SYSTEM COMPONENTS

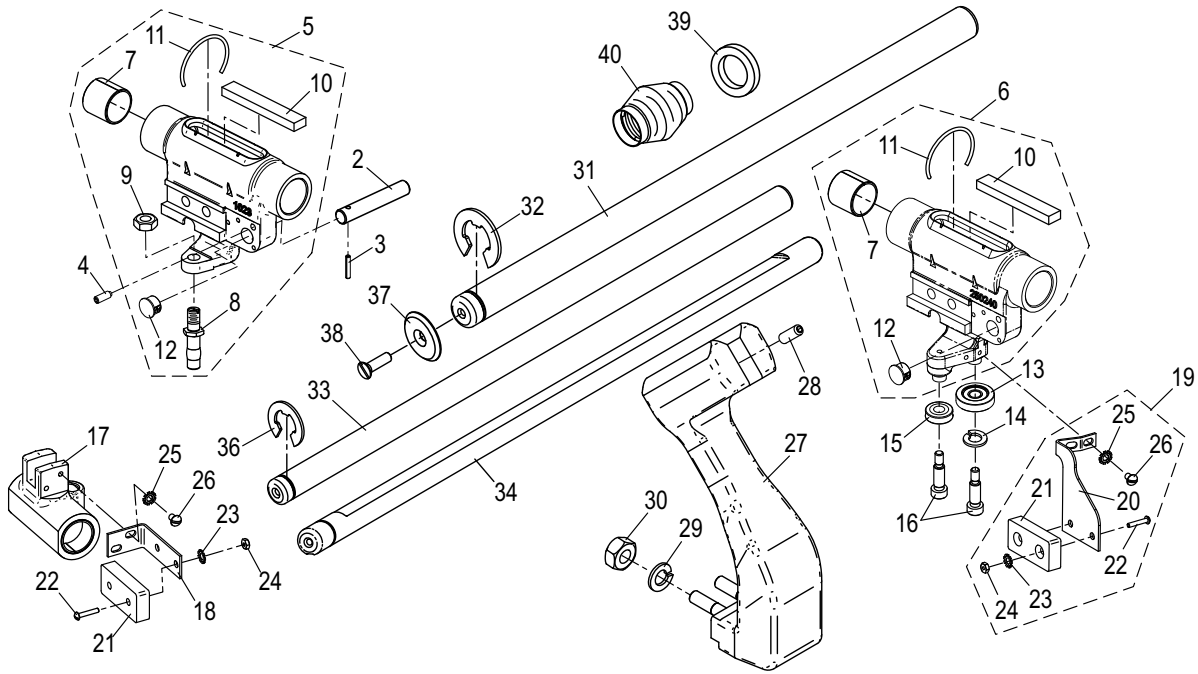

ITEM	PART DESCRIPTION	PART NUMBER	QTY REQD		
			MAN	EZ GLIDE	AUTO
1	UPPER SLIDE ASSY - AUTOMATIC	1278-A	-	-	1
2	CHAIN SLIDE SHAFT	1079	-	-	1
3	ROLL PIN	1235	-	-	1
4	SET SCREW	1270	-	-	2
5	UPPER SLIDE ASSEMBLY - MANUAL	1278	1	-	1
*6	KIT, UPPER SLIDE ASSY - EZ GLIDE (MANUAL)	260070	-	1	-
7	SLIDE BUSHING	436-7	2	2	2
8	STUD, SLIDE ROD BUSHING	241-B	1	-	1
9	NUT	228	1	-	1
10	FELT, OIL	436-3	1	1	1
11	SPRING CLIP	436-4	2	2	2
12	PLUG	850-3	1	1	-
*13	BEARING	520200	-	1	-
*14	LOCKWASHER	890190	-	1	-
*15	ROLLER, SLIDE	520210	-	1	-
*16	BOLT, SHOULDER	810370	-	1	-
17	LOWER SLIDE BUSHING	1342	1	-	1
18	BRACKET, MAGNET MOUNTING	1341	1	-	1
*19	KIT, EZ GLIDE INTERLOCK MAGNET	140063	-	1	-
*20	BRACKET, MAGNET MOUNTING - EZ GLIDE	330110	-	1	-
21	MAGNET, INTERLOCK	985-1	1	1	1
22	SCREW	854-2	2	2	2
23	LOCK WASHER	854-7	2	2	2
24	NUT	854-3	2	2	2
25	LOCK WASHER	854-7	2	2	2
26	SCREW	854-6	2	2	2
27	CHUTE RECEIVER ASSY	250160	1	1	1
28	SET SCREW	167-1	1	1	1
29	LOCKWASHER	245-A	2	2	2
30	NUT	478-2	2	2	2
31	UPPER SLIDE ROD	420050	1	1	1
32	UPPER RETAINING CLIP	857-1	1	1	1
33	LOWER SLIDE ROD	420060	1	-	1
*34	ROLLER SLIDE BAR, LOWER - EZ GLIDE	400070	-	1	-
*35	SET SCREW (NOT SHOWN)	810380	-	1	-
36	LOWER RETAINING CLIP	858-1	1	1	1
37	SLIDE BAR WASHER	859	2	2	2
38	SCREW	859-1	2	2	2
39	SLIDE BUMPER	436-1	1	1	-
40	SPRING, UPPER SLIDE ROD	919-4	1	1	2
41	LUBRICATING OIL (NOT SHOWN)	519		A/R	

\* EZ GLIDE SYSTEM APPLIES TO S/N 4600300 AND UP.

# STAINLESS STEEL CHUTE AND SUPPORT

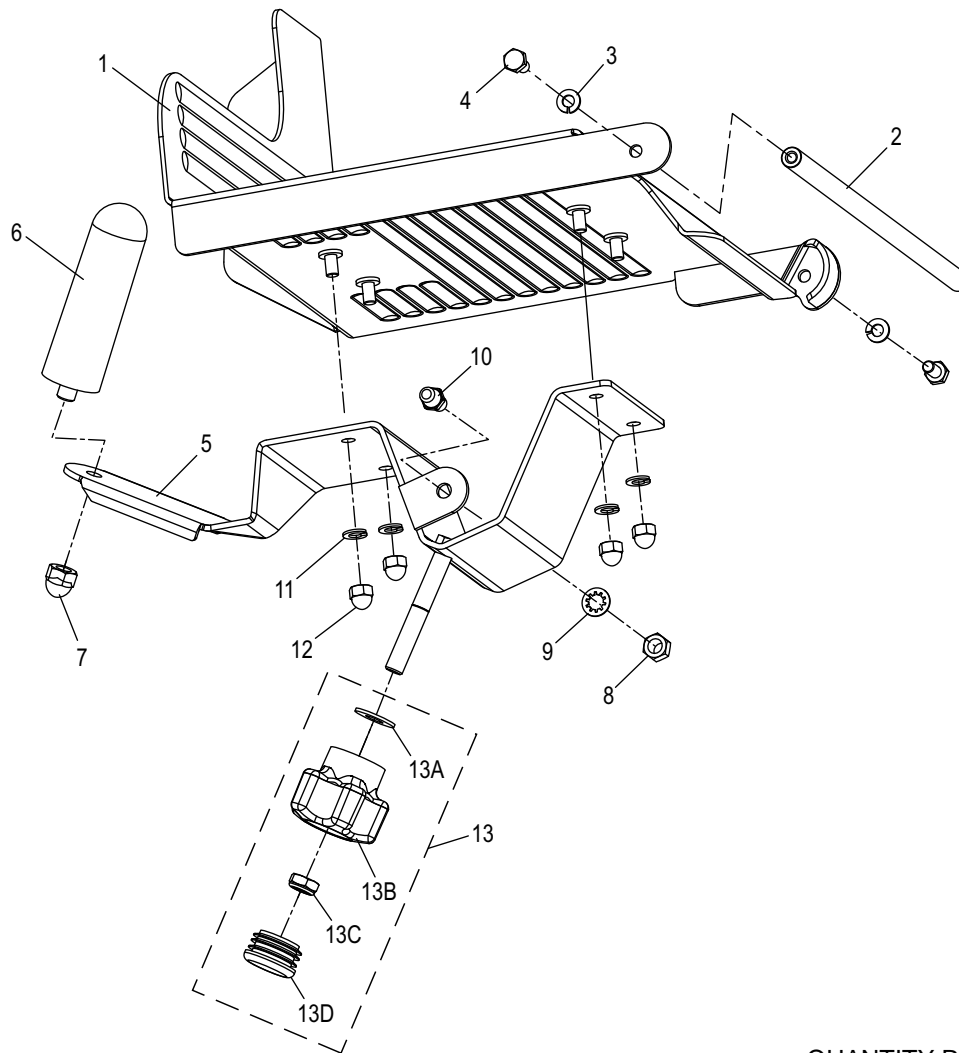

ITEM	PART DESCRIPTION	PART NUMBER	QUANTITY REQD		
			AUTO	MAN	4913
*	14 1/2" SS CHUTE ASSEMBLY WITH PRONGS	102-AS-25	-		1
	12" SS CHUTE ASSEMBLY WITH PRONGS	102-AS-19	1		-
	12" SS CHUTE ASSEMBLY W/O PRONGS	102-AS-20	-	1	-
1	12" CHUTE	962-S	1		-
	14.5" CHUTE	962-M	-		1
2	END WEIGHT ROD - 11-3/16" LONG	962-18S	1		-
	END WEIGHT ROD - 13-11/16" LONG	962-18M	-		1
3	LOCK WASHER	962-16		2	
4	SCREW	962-17		2	
5	CHUTE SUPPORT	330050		1	
6	CHUTE HANDLE	482-B		1	
7	ACORN NUT	699-32		2	
8	ACORN NUT	962-7		1	
9	LOCK WASHER, INTERNAL TOOTH	962-19		1	
10	LOCK BACK STUD	962-5		1	
11	LOCK WASHER	962-16		6	
12	ACORN NUT	962-6		4	
13	CHUTE SUPPORT KNOB ASSEMBLY	510011		1	
13A	FLAT WASHER	-		1	
13B	CHUTE SUPPORT KNOB	-		1	
13C	NYLOCK NUT	-		1	
13D	CAP	840002		1	

\* CHUTE ASSEMBLY INCLUDES END WEIGHT.



# 4000P END WEIGHTS

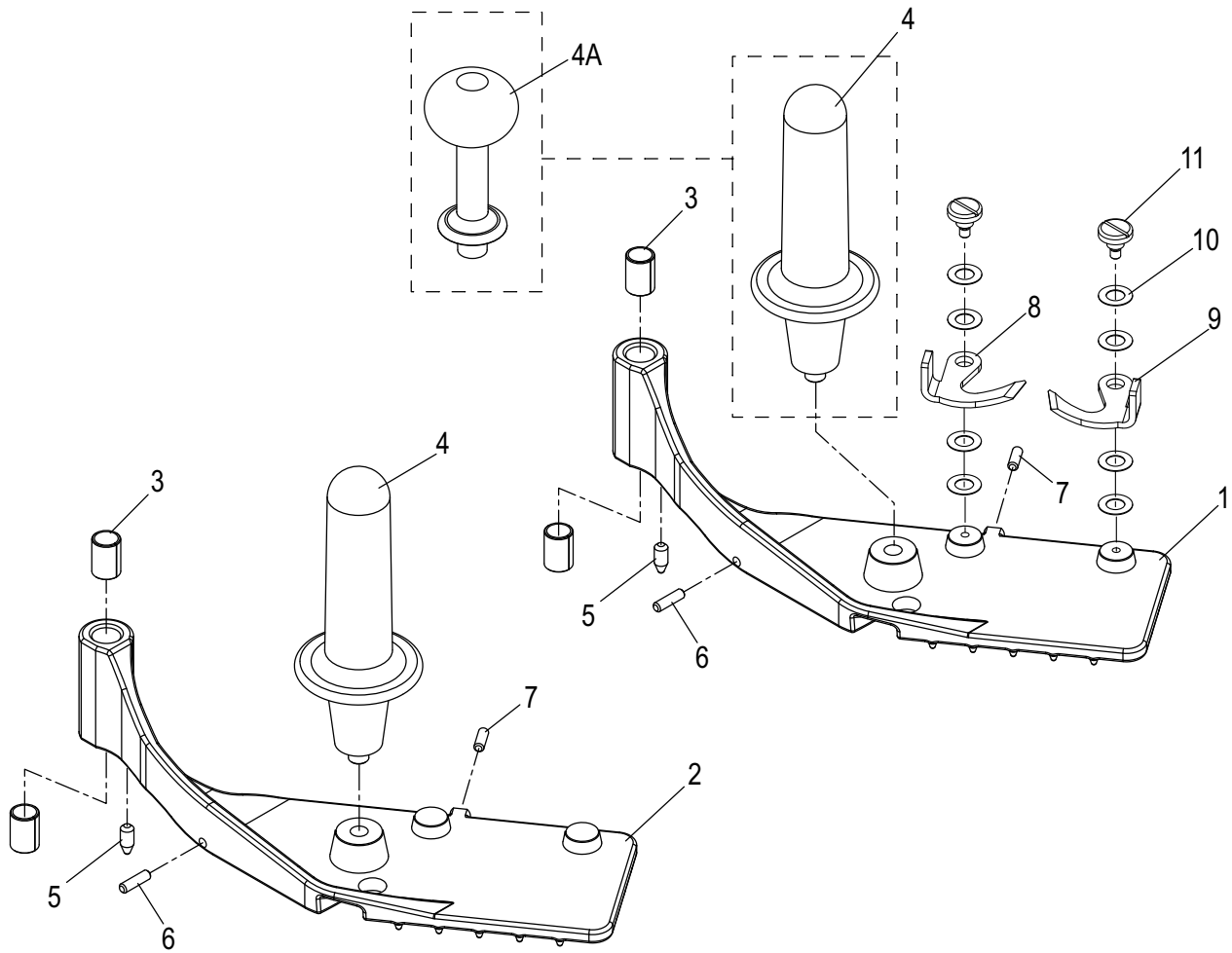

ITEM	PART DESCRIPTION	PART NUMBER	QUANTITY REQD		
			AUTO	MANUAL	4913
	END WEIGHT ASSEMBLY, SS - W PRONGS	741-SS-AA	-	-	1
	END WEIGHT ASSEMBLY, SS - W/O PRONGS	741-SS-AS	-	1	-
	END WEIGHT ASSEMBLY, SS - W/PRONGS	741-SS-APC	1	-	-
1	*AUTOMATIC END WEIGHT, SS	1233	1	-	1
2	*MANUAL END WEIGHT, SS	1234	-	1	-
3	END WEIGHT BUSHING	741-6	2	2	2
4	END WEIGHT HANDLE, PLASTIC	510012	1	1	-
4A	END WEIGHT HANDLE, SS (4913 ONLY)	741-SS3	-	-	1
5	END WEIGHT REST BUMPER	741-4A	1	1	1
6	END WEIGHT SPACER BUMPER	741-5A	1	1	1
7	END WEIGHT CHUTE BUMPER	741-5B	1	1	1
8	END WEIGHT PRONG, RIGHT	741-PC2	1	-	1
9	END WEIGHT PRONG, LEFT	741-PC3	1	-	1
10	SPRING WASHER, PRONG	741-PC5	8	-	8
11	SHOULDER SCREW, PRONG	741-SS4	2	-	2

\* END WEIGHT INCLUDES ITEM 3 (BUSHINGS)

# 4000P SLIDE SYSTEM, AUTOMATIC SLICER

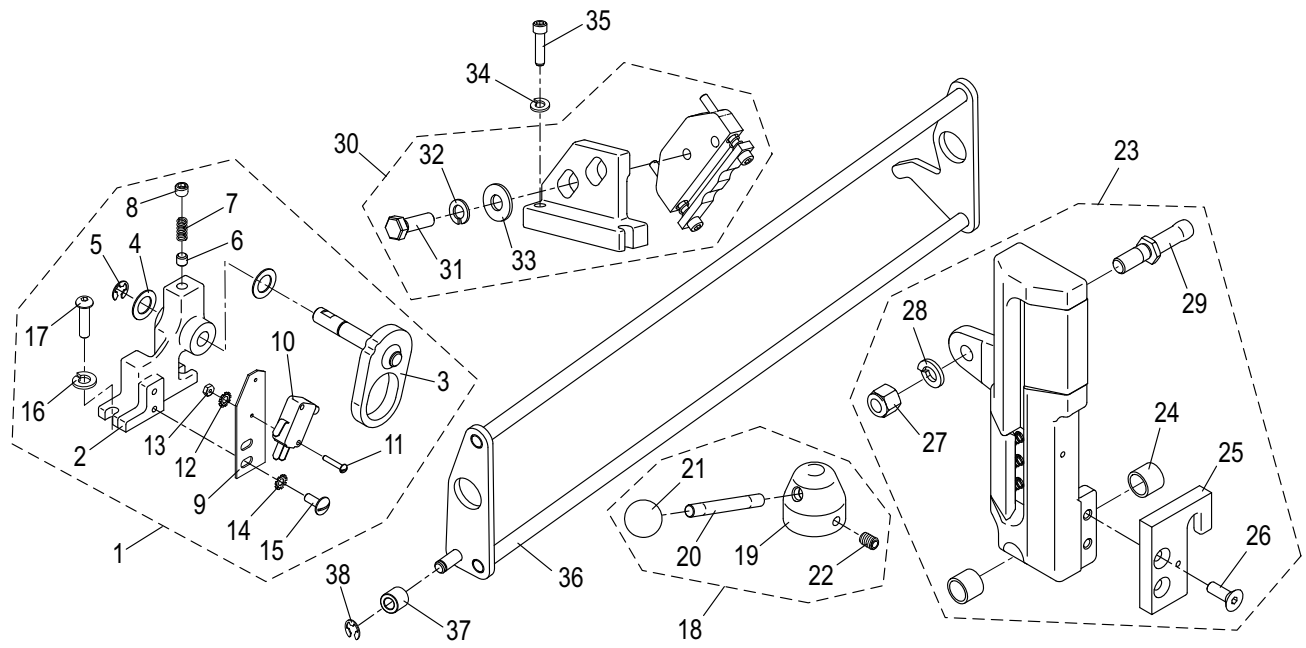

ITEM	PART DESCRIPTION	PART NUMBER	QTY
1	AUTO/MANUAL LEVER ASSEMBLY	1360	1
2	BRACKET, AUTO ENGAGE	1055	1
3	CAM ASSEMBLY	1145	1
4	FIBER WASHER	359	2
5	C-CLIP	940-10	1
6	PLUG	1299	1
7	SPRING	1300	1
8	SET SCREW	1291	1
9	BRACKET, MICROSWITCH	1053	1
10	MICROSWITCH	1263	1
11	SCREW	854-2	2
12	LOCK WASHER	854-7	2
13	NUT	854-3	2
14	LOCK WASHER	854-7	2
15	SCREW	900-1	2
16	LOCK WASHER	1226	2
17	SCREW, BUTTON HD	1217	2
18	AUTO-ENGAGE LEVER ASSEMBLY	1029	1
19	LEVER HUB	1026	1
20	SHAFT	1028	1
21	KNOB	1202	1
22	SET SCREW	810002	1
23	CHAIN SLIDE ASSEMBLY	1308	1
24	BEARING	1166	2
25	ACTUATOR	1119	1
26	SCREW	1089	2
27	LOCK NUT	1297	1
28	LOCK WASHER	962-13	1
29	ECCENTRIC STUD	1080	1
30	ENGAGEMENT SPRING ASSEMBLY	1361	1
31	SCREW	1295	2
32	LOCK WASHER	245-A	2
33	FLAT WASHER	1288	2
34	LOCK WASHER	1226	2
35	SCREW, BUTTON HD	1217	2
36	ROCKER ASSEMBLY	1104	1
37	CAM ROLLER	1102	1
38	C-CLIP	940-10	1

# 4000P AUTOMATIC SLICER CHUTE DRIVE SYSTEM

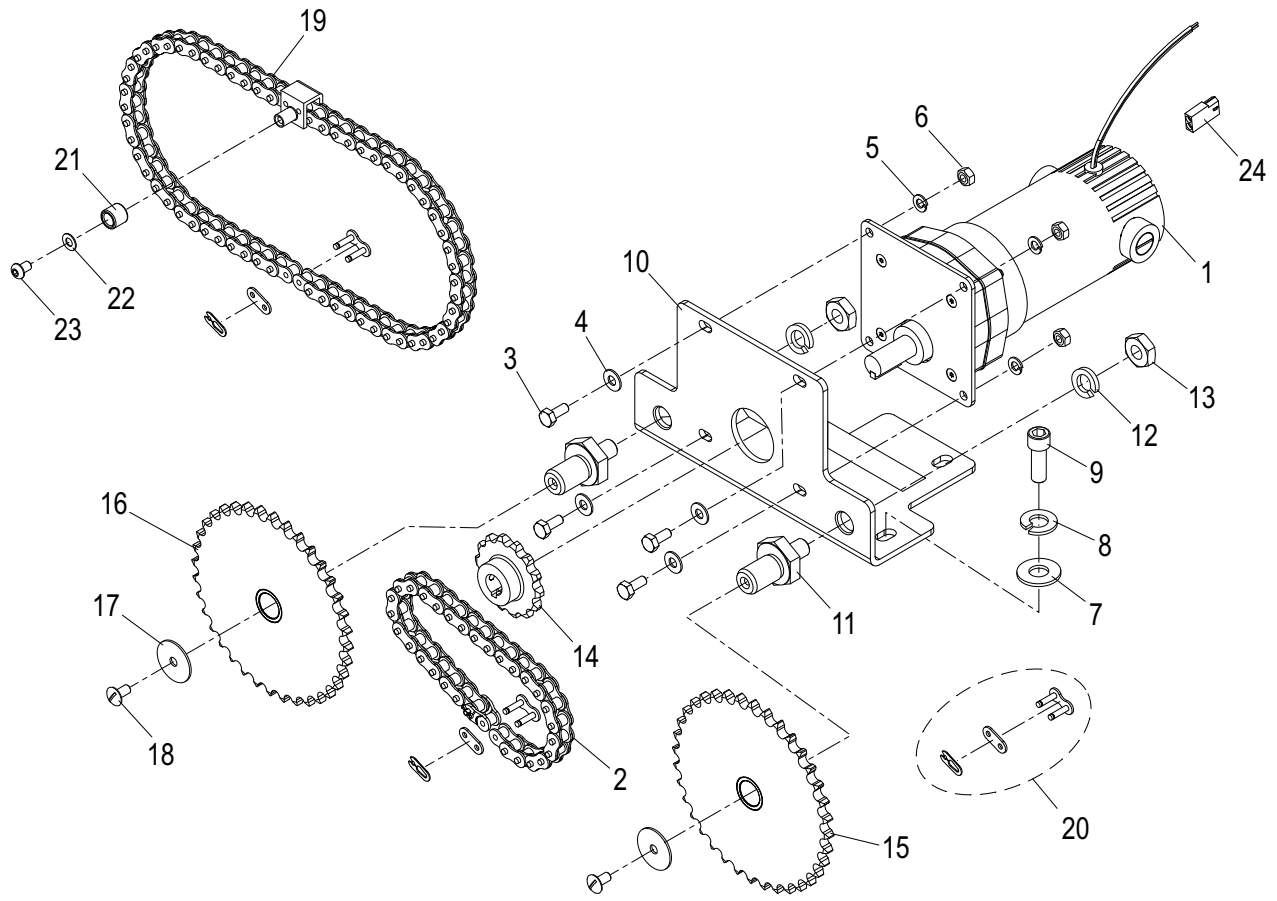

ITEM	PART DESCRIPTION	PART NUMBER	QTY
1	DC GEAR MOTOR	982-1BS	1
2	DRIVE CHAIN (INCLUDES MASTER LINK P/N 1336)	1019	1
3	SCREW	627-C	4
4	FLAT WASHER	825-2	4
5	LOCK WASHER	962-16	4
6	NUT	825-3	4
7	FLAT WASHER	1288	3
8	LOCK WASHER	245-A	3
9	CAP SCREW	1298	3
10	MOTOR MOUNT BRACKET	1082	1
11	SPROCKET STUD	1118	2
12	LOCK WASHER	815	2
13	NUT	646	2
14	MOTOR SPROCKET	1030	1
15	18 & 36 TOOTH SPROCKET	1285	1
16	36 TOOTH SPROCKET	1286	1
17	SPROCKET WASHER	608	2
18	SCREW	762-6	2
19	AUTO DRIVE CHAIN ASSEMBLY	1020	1
20	MASTER LINK	1336	1
21	CAM FOLLOWER	1097	1
22	FLAT WASHER, CAM	870084	1
*23	CAM SCREW	1107	1
24	WIRE CONNECTOR	982-1MH	1

\*MUST SHIP WITH WASHER P/N 870084 (ITEM 22).

# 4000P AUTOMATIC BASE APRON & LIFT LEVER ASSEMBLY

View from bottom of Slicer

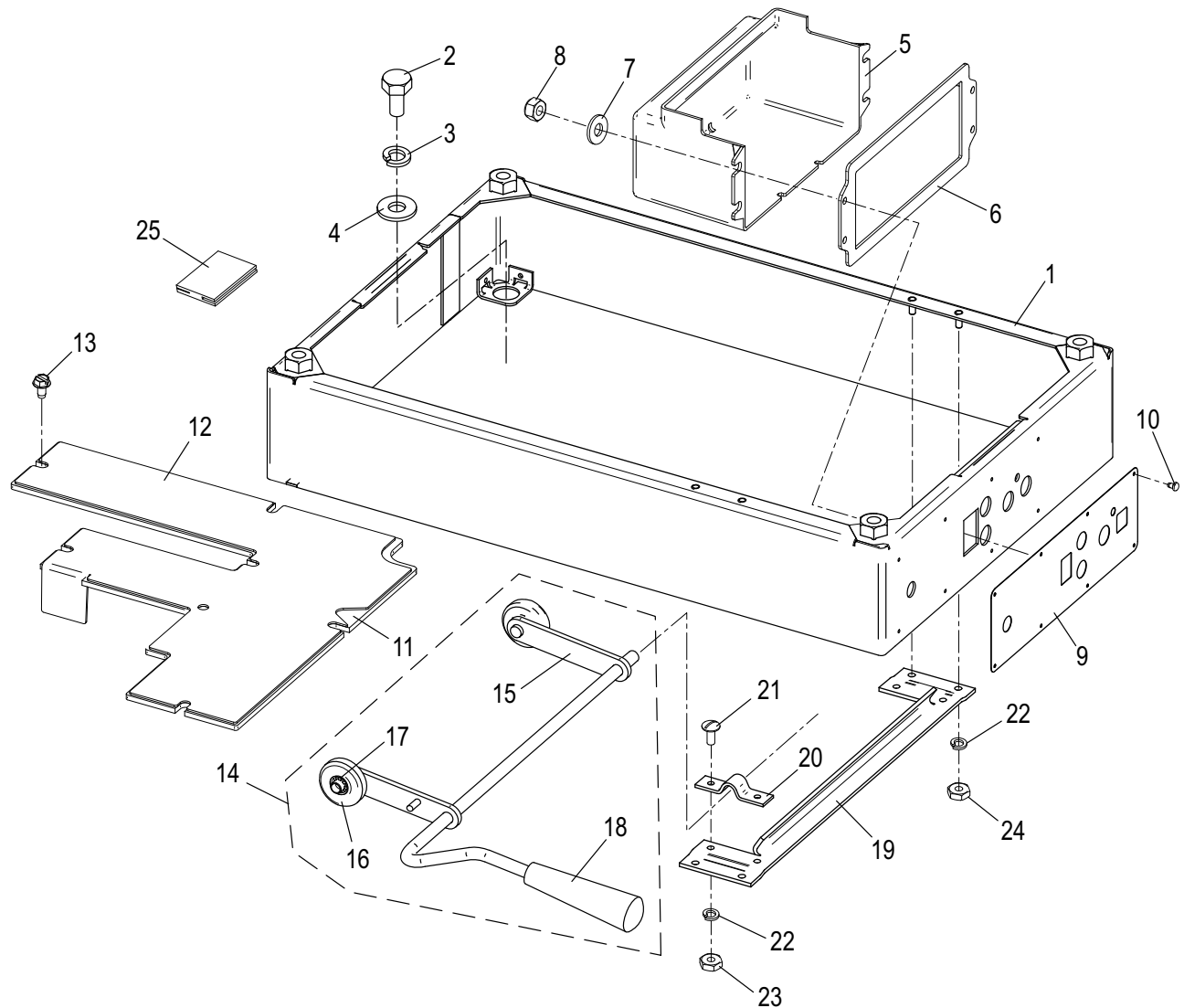

ITEM	PART DESCRIPTION	PART NUMBER	QTY	ITEM	PART DESCRIPTION	PART NUMBER	QTY
1	BASE APRON	1046	1	14	LIFT LEVER ASSEMBLY	1161	1
2	BOLT	813	4	15	LIFT LEVER	1154	1
3	FLAT WASHER	881-4	4	16	WHEEL	951-7	2
4	LOCK WASHER	815	4	17	CLIP	1156	2
5	COVER, ELECTRICAL BOX	1228	1	18	HANDLE	951-8	1
		*520052		19	SUPPORT, LIFT LEVER	1155	1
6	GASKET	1274	1	20	PIVOT ROD CLIP	951-2	2
7	LOCK WASHER	1252	4	21	SCREW	900-1	4
	FLAT WASHER	*870087		22	LOCK WASHER	1252	8
8	NUT	1276	4	23	NUT	760-5	4
	LOCK NUT, NYLON INSERT	*810218		24	NUT	1276	4
9	OVERLAY, TOUCH PAD	1159	1	25	CLIP, BOTTOM COVER	550010	1
10	DRIVE SCREW	851-6P	8	26	COVER, BOTTOM (NOT SHOWN)	340000	1
11	GASKET	1192	1				
12	COVER, WIRE WAY	320041	1	27	LABEL, WIRING DIAGRAM (NOT SHOWN)	910050	1
13	SCREW	889	7			*910216	

\* USE AFTER SERIAL NUMBERS: 4975200 (4975P) & 4913300 (4913)

# 4000P AUTOMATIC SLICER ELECTRICAL SYSTEM

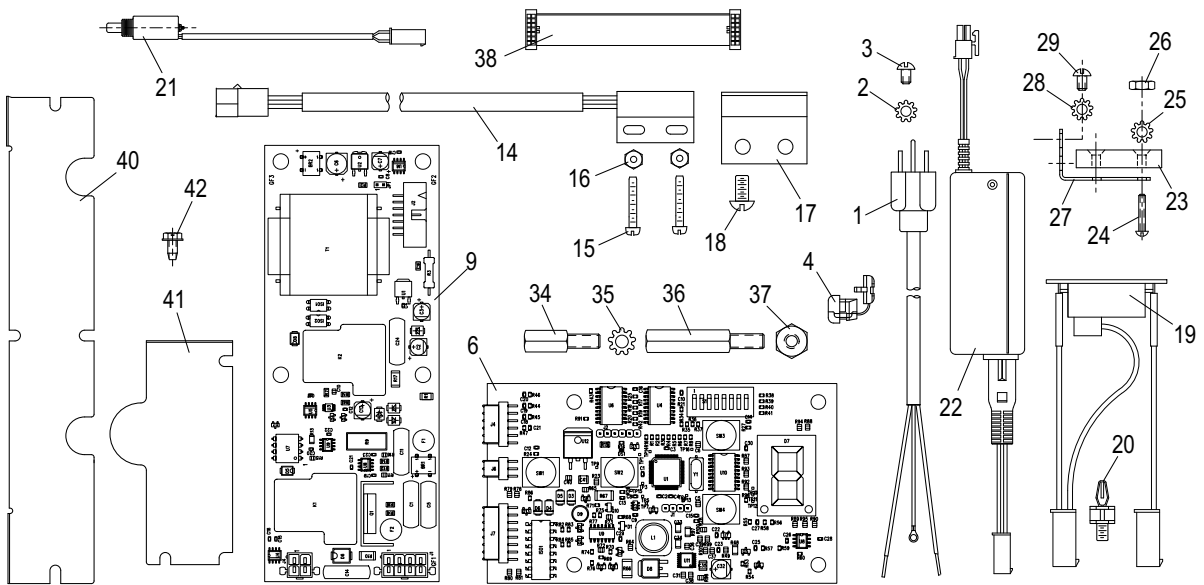

ITEM	PART DESCRIPTION	See Note	PART NUMBER	QTY	P/N 140056 RETROFIT KIT	P/N 140058 UPGRADE KIT
1	POWER CORD		132-3	1		
2	LOCK WASHER, GROUND SCREW		854-7	2		
3	SCREW, POWER CORD GROUND		854-6	2		
4	STRAIN RELIEF, POWER CORD		877	1		
5	WIRING HARNESS, 110VAC (NOT SHOWN)		130200	1		
	WIRING HARNESS, 110VAC (NOT SHOWN) 2nd GEN PCBs	2	130202			
	WIRING HARNESS, 110VAC (NOT SHOWN) 2nd GEN PCBs	3	130194			
	WIRING HARNESS, 110VAC (NOT SHOWN) 2nd GEN PCBs	4	130203			X
6	CIRCUIT BOARD, START/STOP DISPLAY		120032	1		
	CIRCUIT BOARD, START/STOP DISPLAY - MODEL 4913		120030			
	SLICER CONTROLLER BOARD - 2nd GEN PCBs	2	011002			X
7	RETROFIT CIRCUIT BOARD ASSY	2	110034	1	X	
8	STANDOFF, 1.13 LG (NOT SHOWN)	2	180106	4	X	
9	CIRCUIT BOARD, POWER SUPPLY, 110VAC		1344	1		
	CIRCUIT BOARD, POWER SUPPLY, 110VAC - 2nd GEN PCBs	2	011022			X
	CIRCUIT BOARD, POWER SUPPLY, 110VAC - 2nd GEN PCBs	4	011012			
10	STANDOFF, 1.75 LG (NOT SHOWN)	2	180108	4		X
11	COVER, ELECTRICAL BOX - 2nd GEN PCBs (SHOWN ON PAGE 19)	1,2	520052	1	X	X
12	FLAT WASHER (NOT SHOWN)	1,2	870087	4	X	X
13	NUT, NYLON INSERT (NOT SHOWN)	1,2	810218	4	X	X
14	PROXIMITY SWITCH (HOME, TIMER & KNIFE GUARD)	3	130020	3		
15	SCREW, SWITCH MOUNTING		995-31	4		
16	NUT		854-3	4		
17	BRACKET, SWITCH MOUNTING - KNIFE GUARD		310130	1		
18	SCREW		1223	2		
19	MOTOR START SWITCH ASSY, SOLID STATE, 110VAC		130050	1		
20	STAND-OFF, MOTOR START SWITCH		1250	2		
21	SOLENOID ASSY, TABLE LOCK-OUT		130090	1		
22	POWER SUPPLY, 24V	4	130060	1		
23	MAGNET, INTERLOCK		985-1	1		
24	SCREW, MAGNET MOUNTING		854-2	2		
25	LOCK WASHER		854-7	2		
26	NUT		854-3	2		
27	BRACKET, MAGNET MOUNTING		1341	1		
28	LOCK WASHER		854-7	2		
29	SCREW BRACKET MOUNTING		854-6	2		
34	STANDOFF		1294	4		
35	LOCK WASHER		854-7	4		
36	STANDOFF		1293	4		
37	NUT		1219	4		
38	RIBBON CABLE	2	1367	1	X	X
39	RIBBON CABLE RETAINING CLIP (NOT SHOWN)	2	180100	2	X	X
40	COVER, WIREWAY # 2		1136	1		
41	COVER, WIREWAY # 3		1137	1		
42	SCREW, WIREWAY COVER		889	7		
43	INSTRUCTION SHEET, RETROFIT KIT (NOT SHOWN)	2	999232	1	X	
44	INSTRUCTION SHEET, UPGRADE KIT (NOT SHOWN)	2	999233	1		X

1. Also shown on page 19.

2. Use with retrofit or upgrade kit before serial numbers: 4975200 (4975) & 4913300 (4913)

3. Timer Reset Switch (130020) 4975300 (4975) & 491500 (4913). Use Wire Harness 130194.

4. DC Power Supply (130060) only used before serial numbers: 4975400(4975) & 4913600 (4913). Use Wire Harness 130203.

# FRONT MOUNTED END WEIGHT CHUTE ASSEMBLY

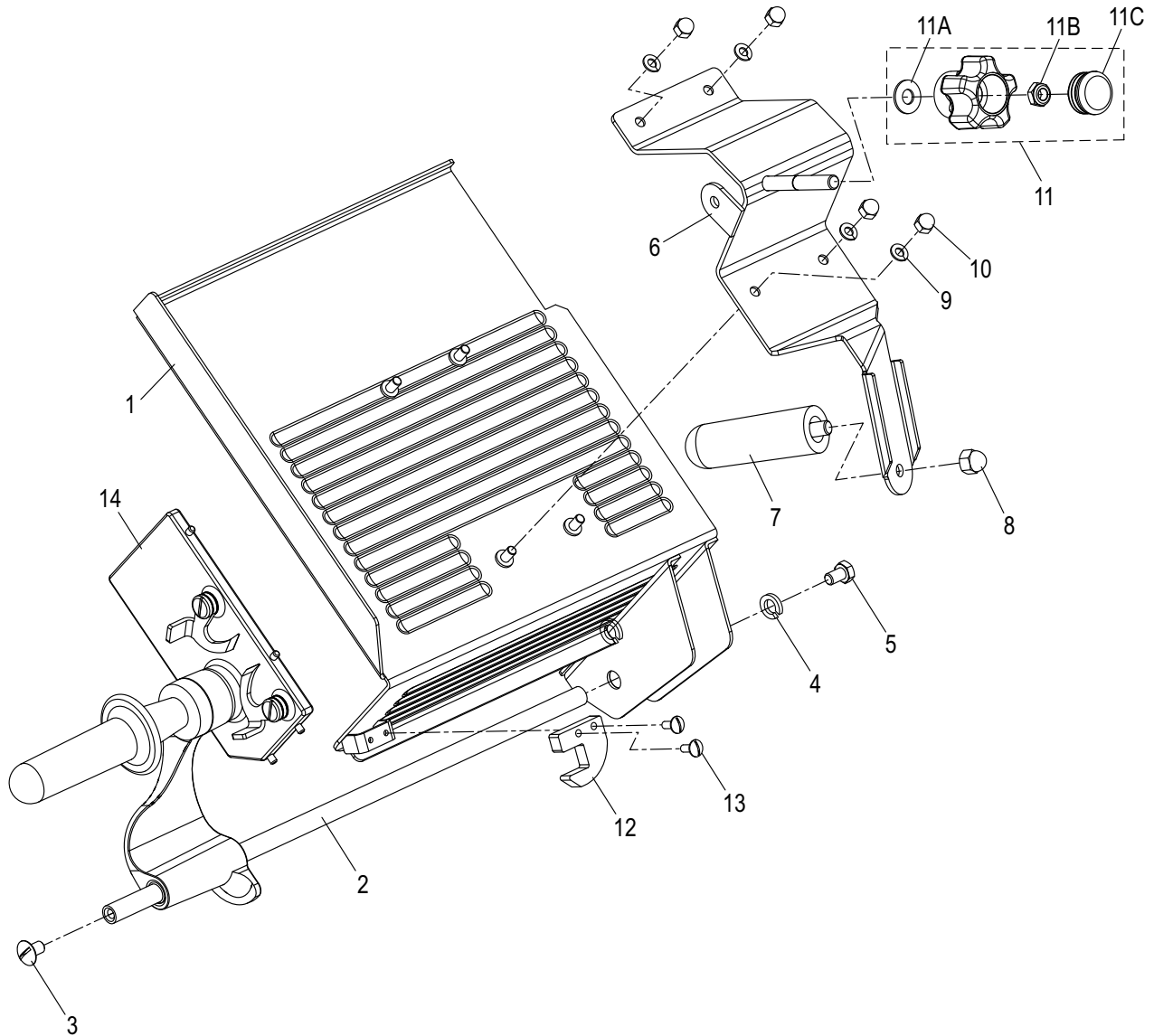

ITEM	PART DESCRIPTION	PART NUMBER	QTY
	CHUTE ASSY W/FRONT MOUNTED END WEIGHT	102-AS-21	1
1	FRONT MOUNTED END WEIGHT CHUTE	981	1
2	END WEIGHT ROD	981-1	1
3	SCREW	981-2	1
4	LOCK WASHER	962-13	1
5	SCREW	981-9	1
6	CHUTE SUPPORT	330050	1
7	CHUTE HANDLE	482-B	1
8	ACORN NUT	699-32	1
9	LOCK WASHER	962-16	4
10	ACORN NUT	962-6	4
11	CHUTE SUPPORT NUT	510011	1
11A	FLAT WASHER	-	1
11B	NYLOCK NUT	-	1
11C	CAP	840002	1
12	ENDWEIGHT REST	981-4	1
13	SCREW	900-1	2
14	END WEIGHT ASSY, FRONT MOUNTED	981-3	1

# 4000P FRONT MOUNTED END WEIGHT ASSEMBLY

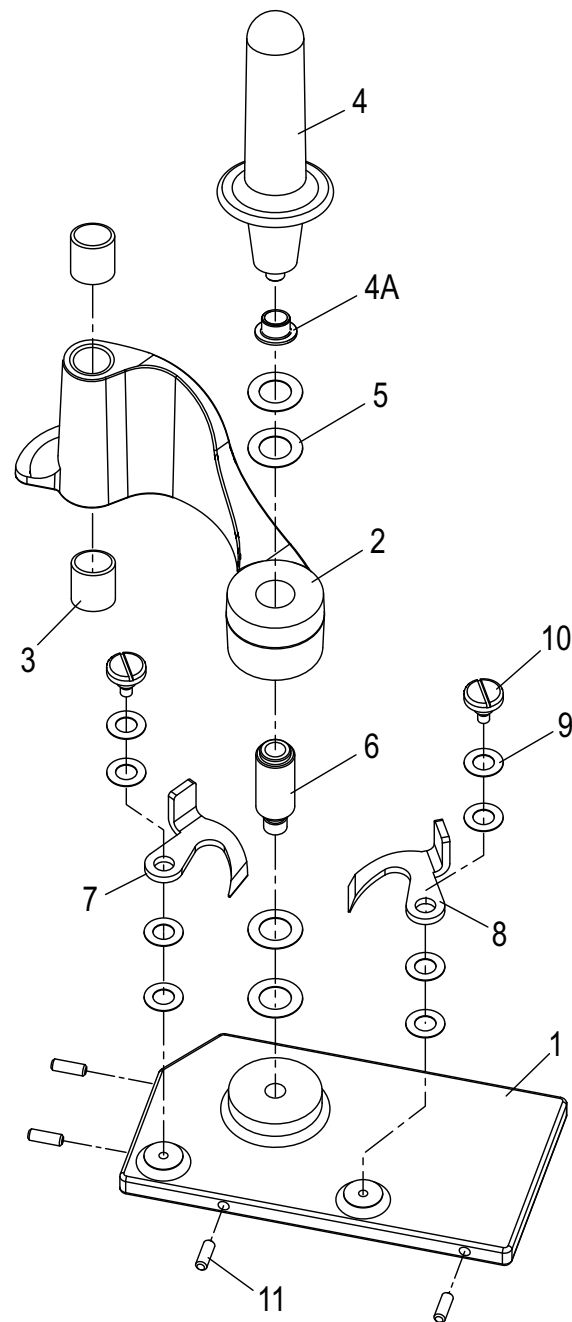

ITEM	PART DESCRIPTION	PART NUMBER	QTY
	FRONT MOUNTED END WEIGHT ASSY, SS - W/PRONGS	981-3	1
1	FRONT MOUNTED END WEIGHT, SS	981-3G	1
*2	END WEIGHT ARM, SS	250010	1
3	END WEIGHT BUSHING	981-3B	2
4	END WEIGHT HANDLE	510012	1
4A	FLANGE BEARING	520205	1
5	BOW WASHER	810060	4
6	END WEIGHT STUD	981-8	1
7	END WEIGHT PRONG, LEFT	741-PC3	1
8	END WEIGHT PRONG, RIGHT	741-PC2	1
9	SPRING WASHER, PRONG	741-PC5	8
10	SHOULDER SCREW, PRONG	741-SS4	2
11	END WEIGHT CHUTE BUMPER	741-5B	4

\* END WEIGHT ARM INCLUDES ITEM 3 (BUSHINGS)

# 4000P VEGETABLE HOPPER ACCESSORY

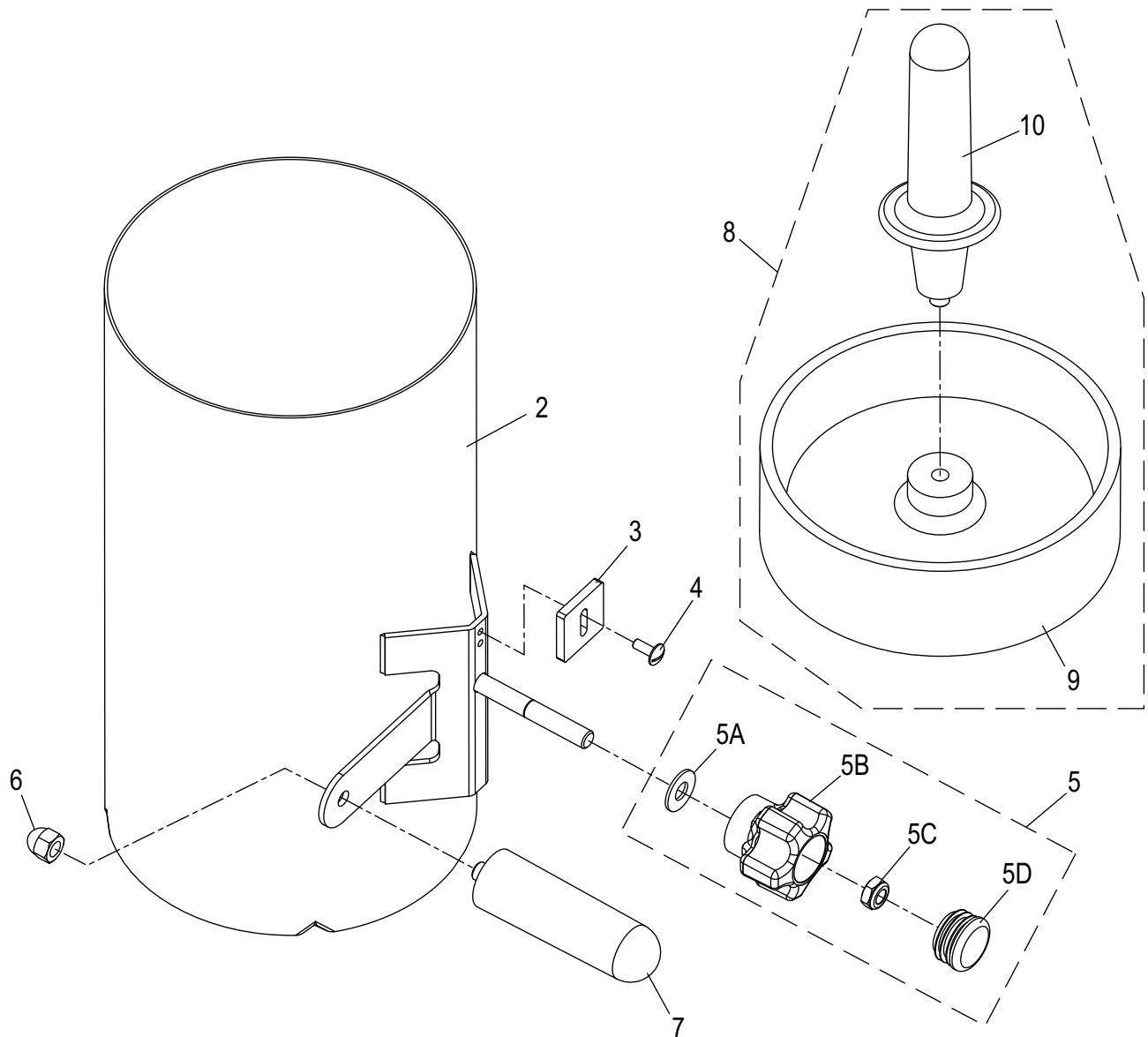

ITEM	PART DESCRIPTION	PART NUMBER	QTY
1	VEGETABLE HOPPER ASSEMBLY	699-BAS	1
2	HOPPER BODY WITH SUPPORT AND STUD	030041	1
3	HOPPER STOP	699-33	1
4	HOPPER STOP SCREW	900-1	1
5	HOPPER SUPPORT KNOB ASSEMBLY	510011	1
5A	FLAT WASHER	-	1
5B	KNOB	-	1
5C	NYLOCK NUT	-	1
5D	CAP	840002	1
6	ACORN NUT	699-32	1
7	HOPPER HANDLE	482-B	1
8	HOPPER END WEIGHT ASSEMBLY	699-16	1
9	HOPPER END WEIGHT	699-17	1
10	HOPPER END WEIGHT HANDLE	741-SS3	1



# 4000P CHUTE FENCE ACCESSORIES

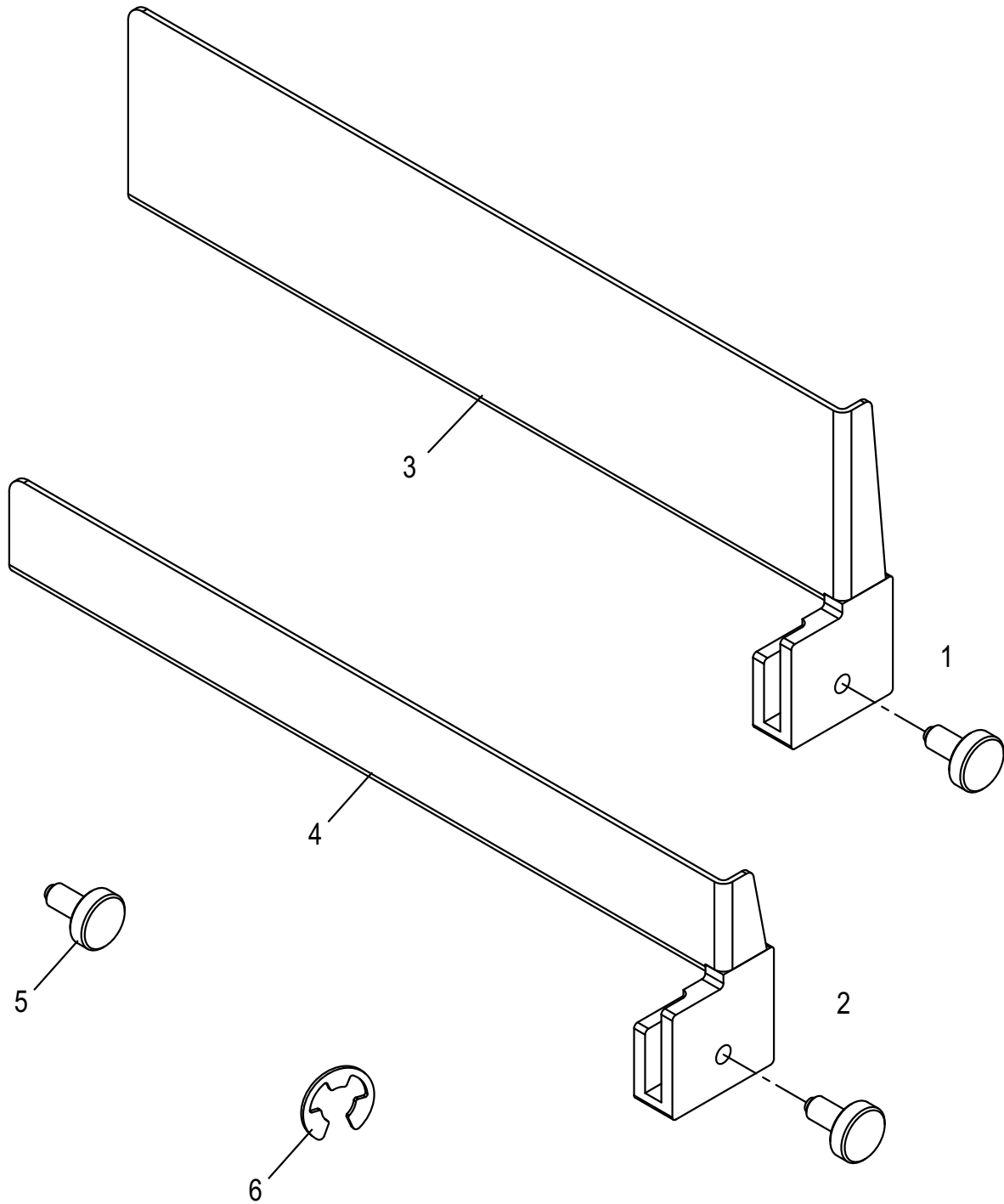

ITEM	DESCRIPTION	PART NUMBER	QTY
1	FENCE ASSEMBLY, 12" X 3"	1326	1
2	FENCE ASSEMBLY, 12" X 1-3/8"	1047	1
3	FENCE, 12" X 3"	1048	1
4	FENCE, 12" X 1-3/8"	1051	1
5	CLAMP THUMB SCREW	1052	1
6	RETAINING RING	940-10	1

# 4000P MANUAL SLICER ELECTRICAL SYSTEM

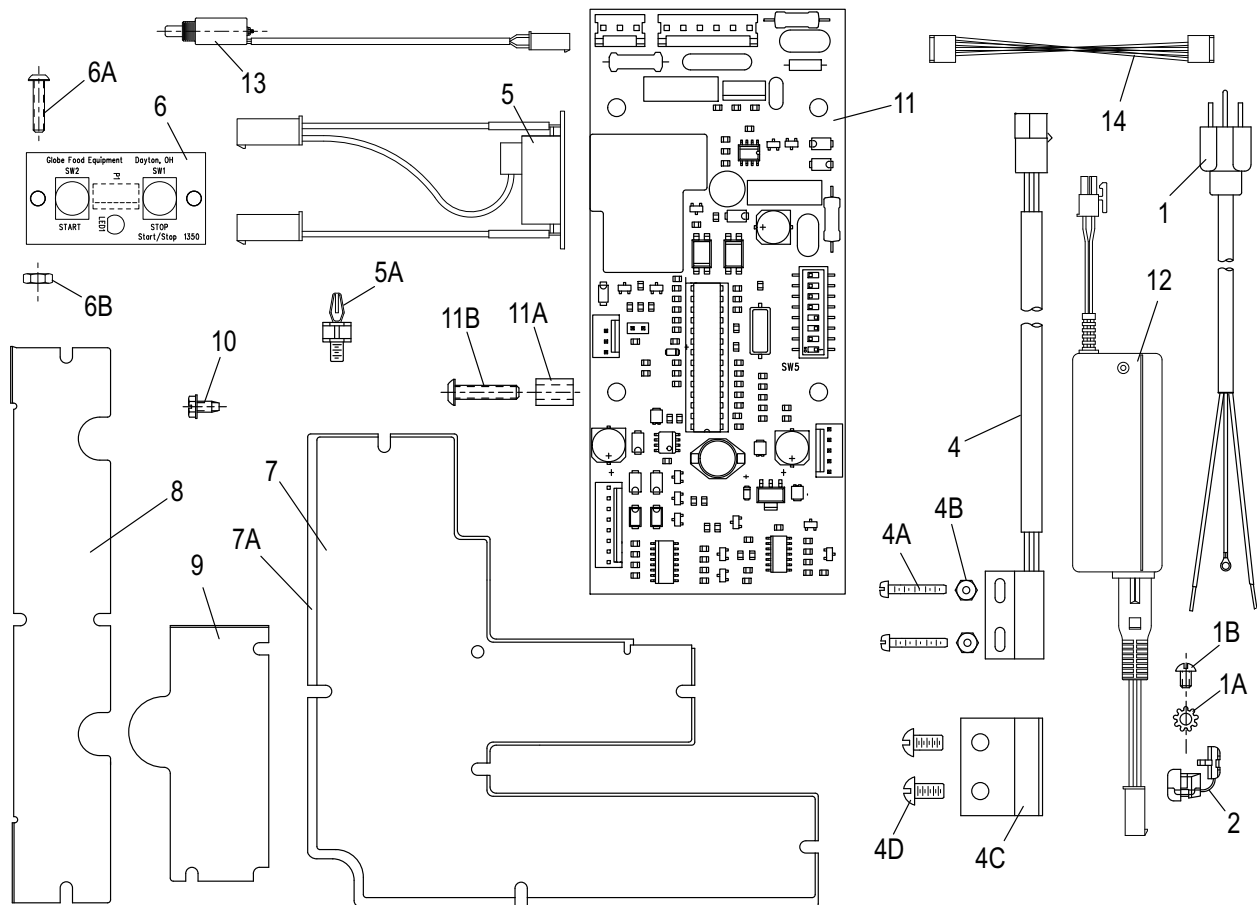

ITEM	PART DESCRIPTION	PART NUMBER	QTY
1	POWER CORD	132-3	1
1A	LOCK WASHER	854-7	2
1B	SCREW	854-6	2
2	STRAIN RELIEF, POWER CORD	877	1
3	WIRING HARNESS, 110VAC (NOT SHOWN)	130121	1
4	PROXIMITY SWITCH (HOME, TIMER & KNIFE GUARD)	130020	3
4A	SCREW	995-31	4
4B	NUT	854-3	4
4C	BRACKET, SWITCH MOUNTING - KNIFE GUARD	1133	1
4D	SCREW	1223	2
5	MOTOR START SWITCH ASSY, SOLID STATE, 110VAC	130050	1
5A	STAND-OFF, MOTOR START SWITCH	1250	2
6	CIRCUIT BOARD, START/STOP	1350	1
6A	SCREW	1218	2
6B	NUT	765-5	2
7	COVER, WIREWAY	320020	1
7A	GASKET, WIREWAY COVER	1192	1
8	COVER, WIREWAY # 2	1136	1
9	COVER, WIREWAY # 3	1137	1
10	SCREW, WIREWAY COVER	889	14
11	CIRCUIT BOARD, LOGIC	120033	1
11A	STAND-OFF	1216	4
11B	SCREW	1218	4
12	POWER SUPPLY, 24V	130060	1
13	SOLENOID ASSY, TABLE LOCK-OUT	130090	1
14	JUMPER CABLE	1377	1

# MANUAL SLICER SCHEMATIC - MODEL 4600P

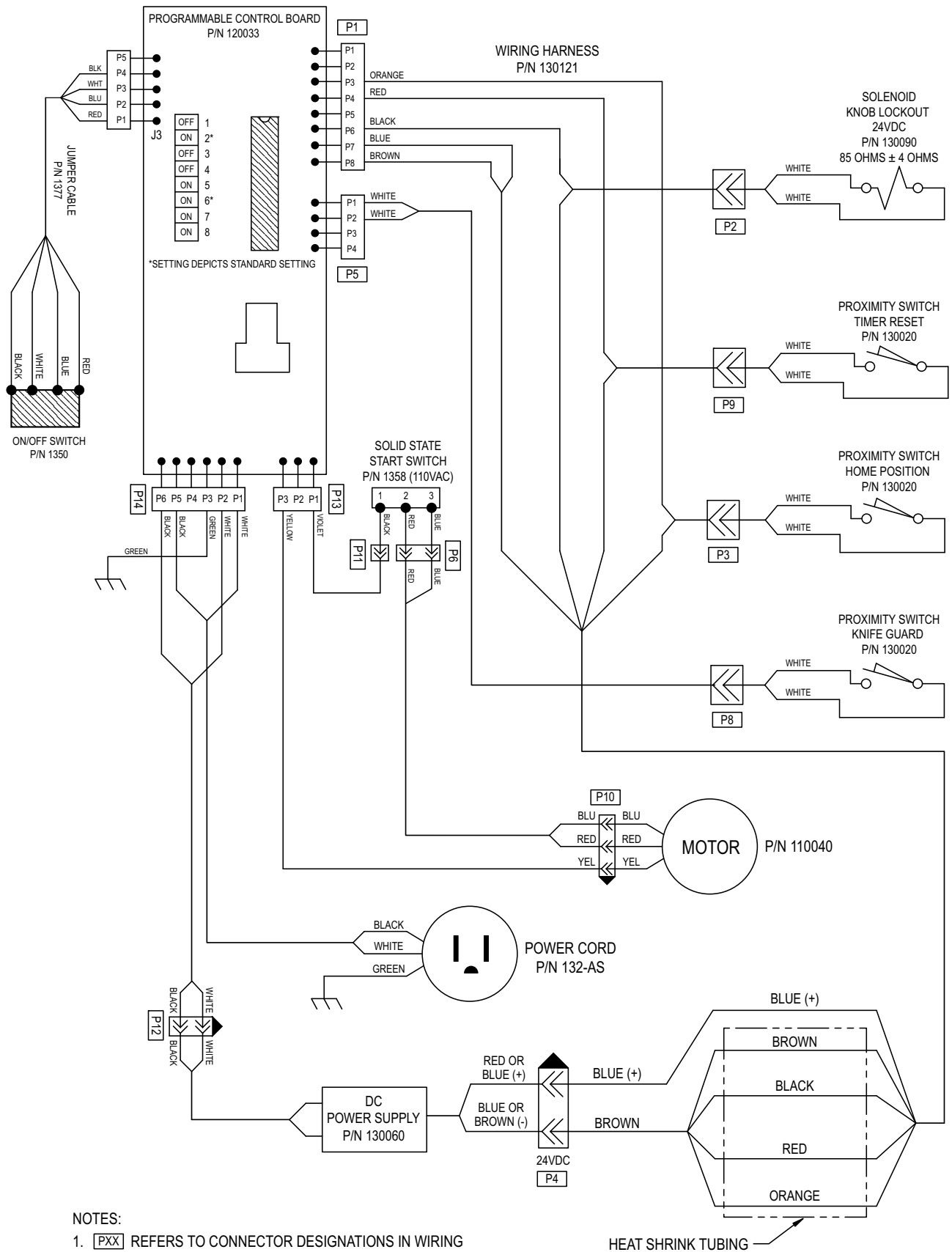

# AUTOMATIC SLICER SCHEMATIC - MODELS 4975P & 4913

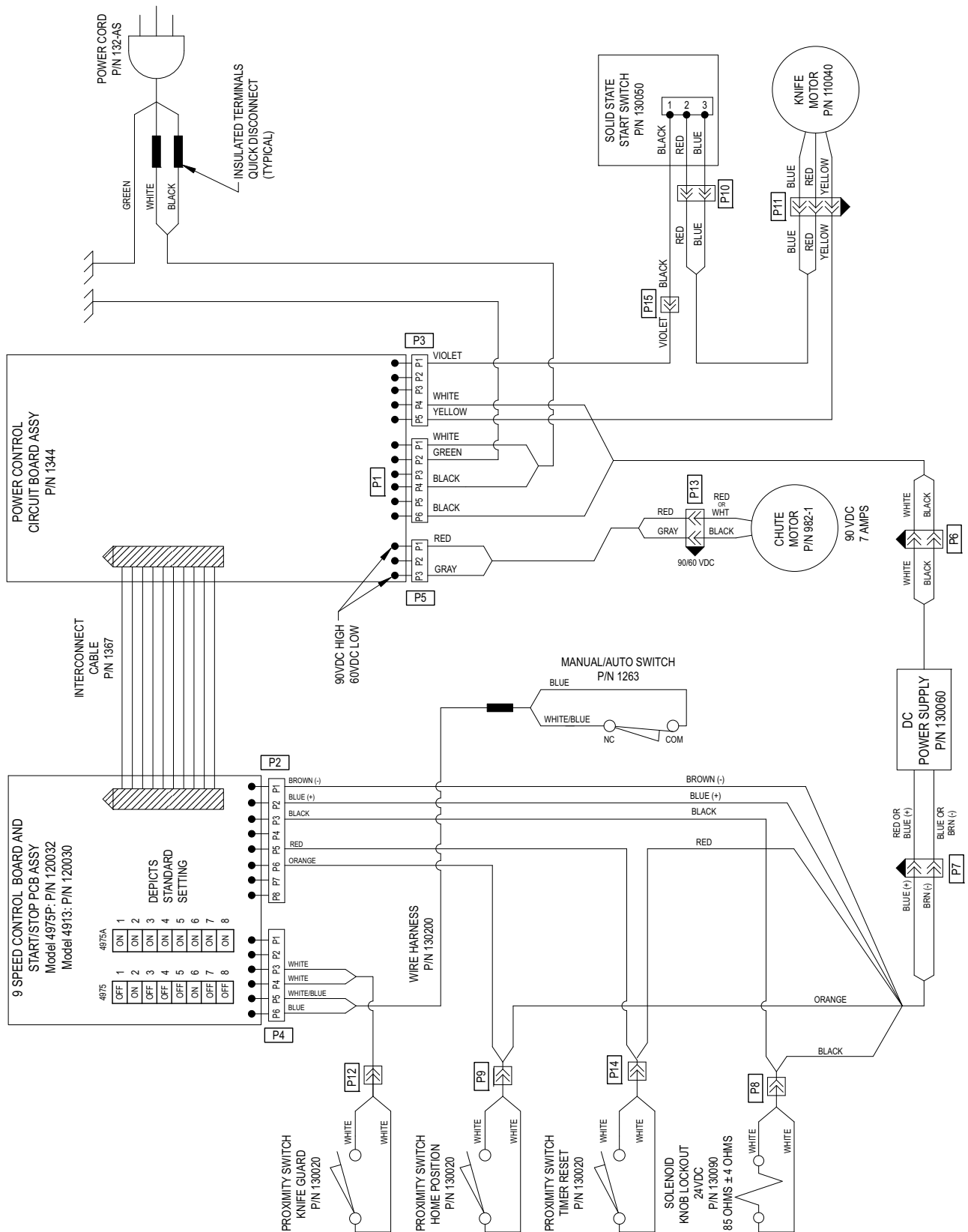

# AUTOMATIC SLICER SCHEMATIC - MODELS 4975P & 4913

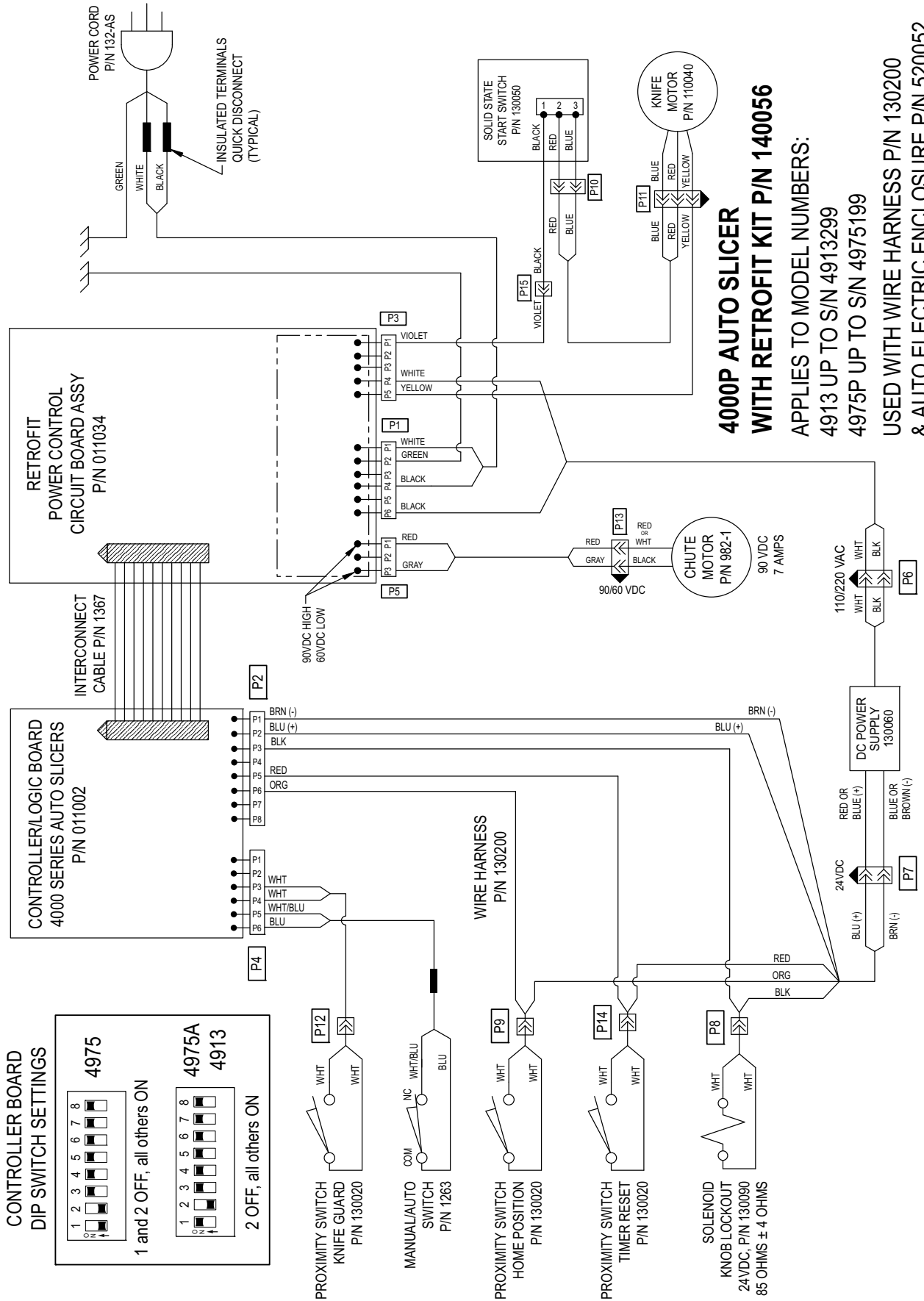



# AUTOMATIC SLICER SCHEMATIC - MODELS 4975P & 4913

## 4000P AUTO SLICER WITH 2nd GENERATION CIRCUIT BOARDS

APPLIES TO MODEL NUMBERS:

4913 STARTING S/N 4913300

4975P STARTING S/N 4975200

WIRE HARNESS P/N 130202 (130194 W/O TIMER RESET SW)

& AUTO ELECTRIC ENCLOSURE P/N 520052

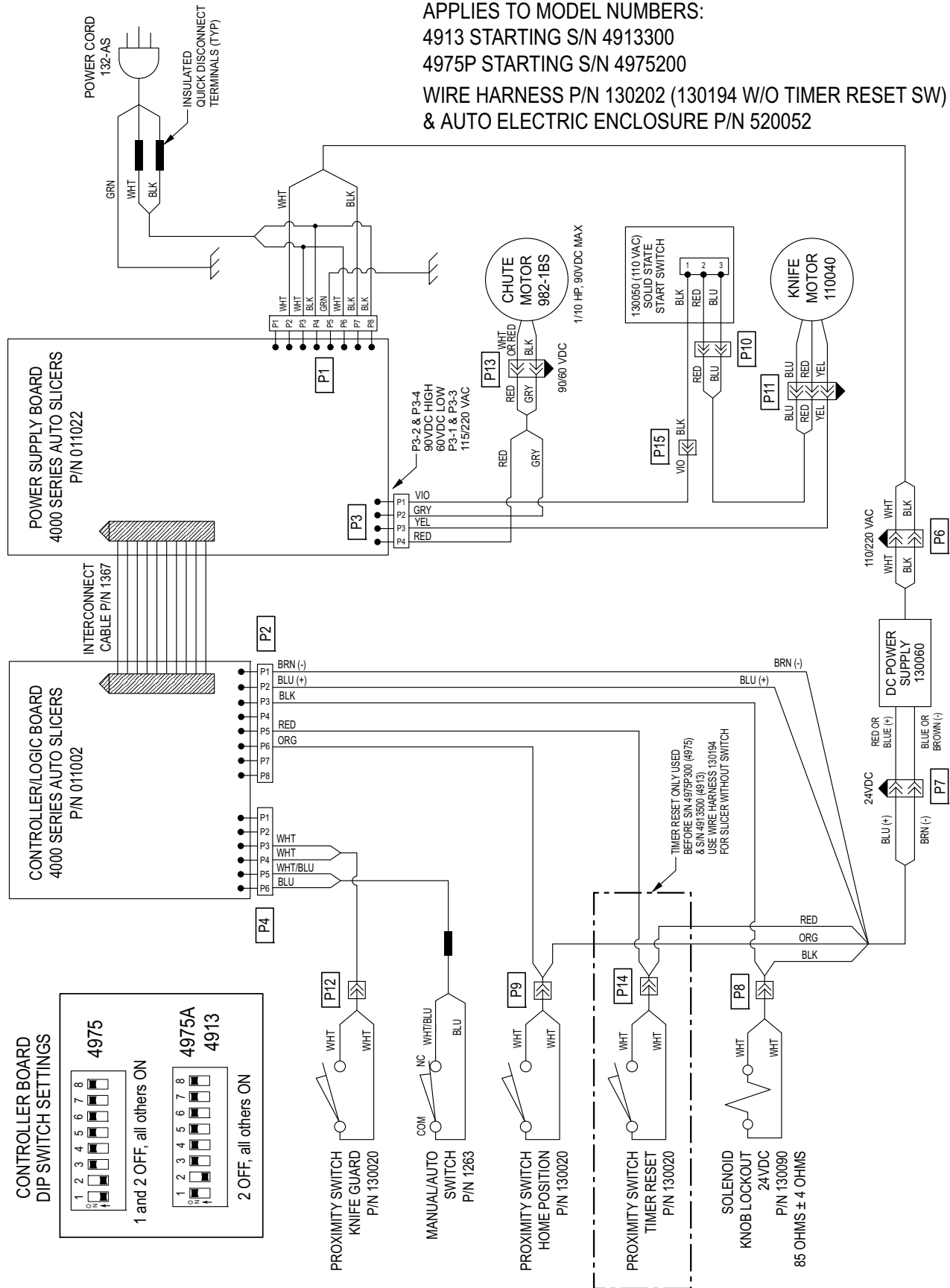

# AUTOMATIC SLICER SCHEMATIC - MODELS 4975P & 4913

## 4000P AUTO SLICER / 2nd GEN PCBs WITHOUT DC POWER SUPPLY

APPLIES TO MODEL NUMBERS:

4913 STARTING S/N 4913600

4975P STARTING S/N 4975400

USED WITH WIRE HARNESS P/N 130203

& AUTO ELECTRIC ENCLOSURE P/N 520052

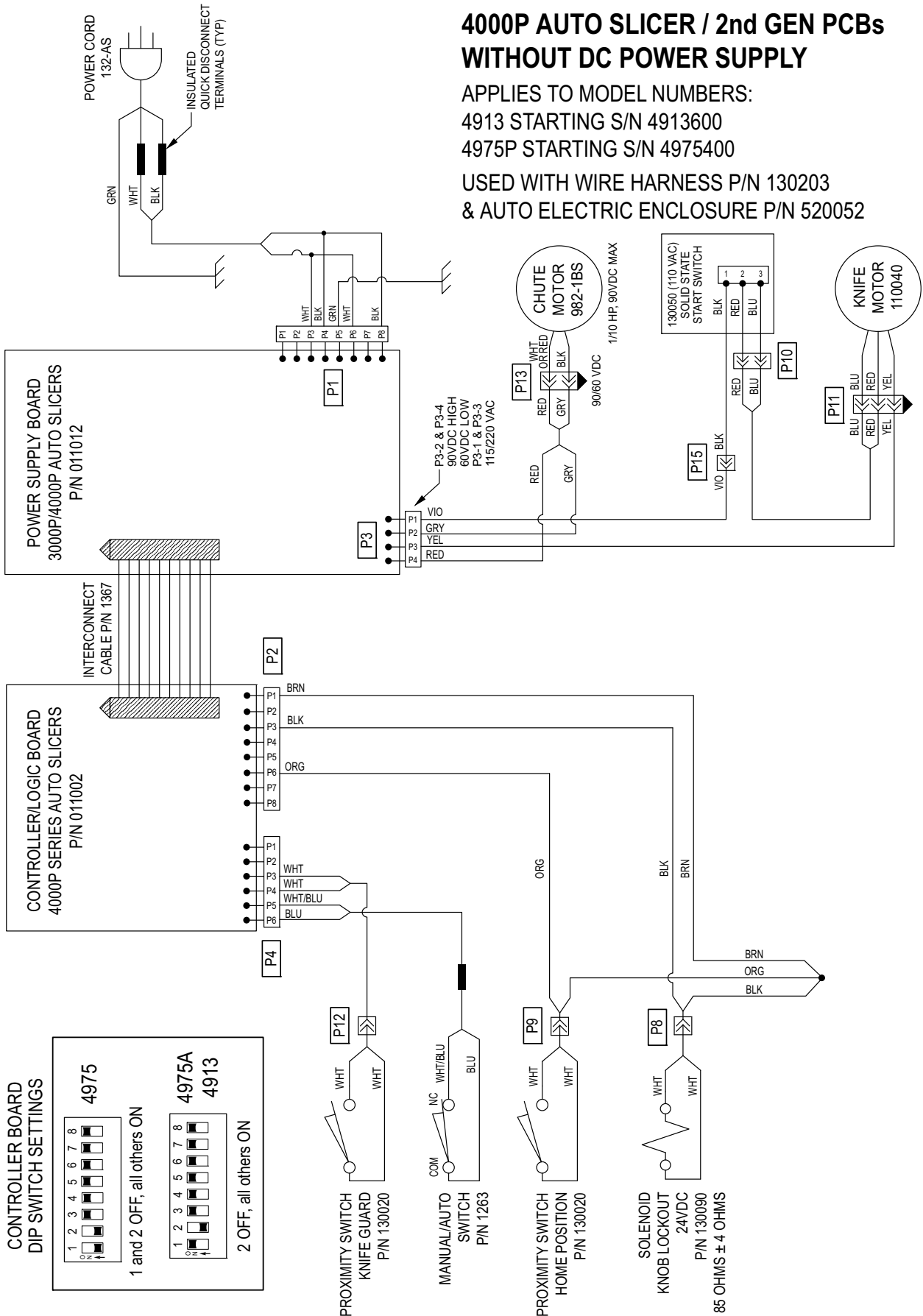



# NOTES

