



OWNER & OPERATOR INSTRUCTION MANUAL

Model # _____

Serial # _____



FOR ARBY'S® SLICER MODEL 4913

For Service on your Slicer

1. Visit our website at www.globeslicers.com
(select the Support / Parts drop down).
2. Or call the Globe service department at 937-297-7247 and ask for contact information for your local service company.

Visit our website for information on additional products available from Globe.

www.globeslicers.com

Slicers, Mixers, Countertop Cooking Equipment, Meat Choppers & Scales

- IMPORTANT SAFETY NOTICE -

This manual contains important safety instructions which must be strictly followed when using this equipment.

INDEX

ATTENTION OWNERS AND OPERATORS.....	3
KEY COMPONENTS OF THE SLICER	4
GLOBE SLICER SAFETY TIPS	5
INSTALLATION AND PROPER GROUNDING	6-7
OPERATING INSTRUCTIONS.....	8-9
CLEANING	10-12
KNIFE SHARPENING	13-15
SIMPLE MAINTENANCE AND REPAIR.....	16-17
OPTIMAL SLICING PERFORMANCE	18
SERVICE AND TROUBLESHOOTING	19
LIMITED WARRANTY	20



GLOBE FOOD EQUIPMENT COMPANY
2153 DRYDEN RD
DAYTON, OH 45439
Toll Free: 800-347-5423
PHONE: 937-299-5493
FAX: 937-299-8623
E-MAIL: info@globeslicers.com
WEBSITE: www.globeslicers.com

ATTENTION OWNERS AND OPERATORS

Globe's equipment is designed to provide safe and productive processing of food products as long as the equipment is used in accordance with the instructions in this manual and is properly maintained. Importantly, unless the operator is adequately trained and supervised there is a possibility of serious injury. Owners of this equipment bear the responsibility to make certain that this equipment is used properly and safely. Strictly following all the instructions contained in this manual and the requirements of local, state or federal law.

Owners should not permit anyone to touch this equipment unless they are over 18 years old, are adequately trained and supervised, and have read and understood this manual. Owners should also ensure that no customers, visitors or other unauthorized personnel come in contact with this equipment. Please remember that Globe cannot anticipate every circumstance or environment in which its equipment will be operated. It is the responsibility of the owner and the operator to remain alert to any hazards posed by the function of this equipment -- particularly the sharp knife blade and all moving parts. If you are ever uncertain about a particular task or the proper method of operating this equipment, ask your supervisor.

This manual contains a safety tips section listing a number of precautions to follow to help promote safe use of this equipment. Throughout the manual you will see additional warnings to help alert you to potential hazards.

Warnings affecting your personal safety are indicated by:



Warnings related to possible damage to the equipment are indicated by:



Make certain that this manual is available for easy reference by any operator. Globe has put several warning labels in the English language on its slicers. Spanish labels are packed in the shipping carton and can replace the English labels at the owner's discretion. If the warning labels or this manual are misplaced, damaged, or illegible, or if you require additional copies, please contact your nearest representative or Globe directly for these items at no charge.

Please remember that this manual and the warning labels do not replace the need to be alert, properly train and supervise operators, and use common sense when using this equipment.

KEY COMPONENTS OF THE SLICER

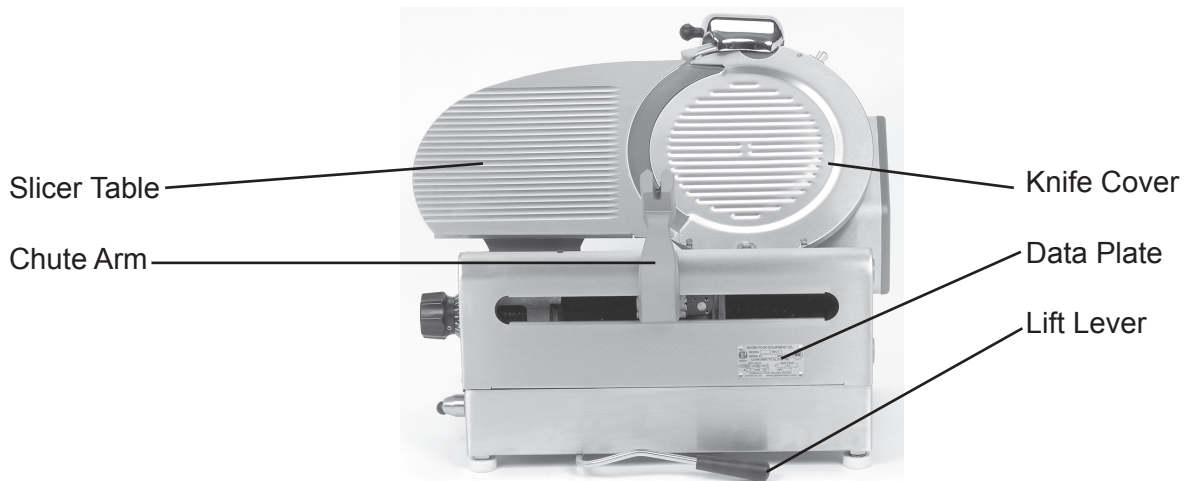
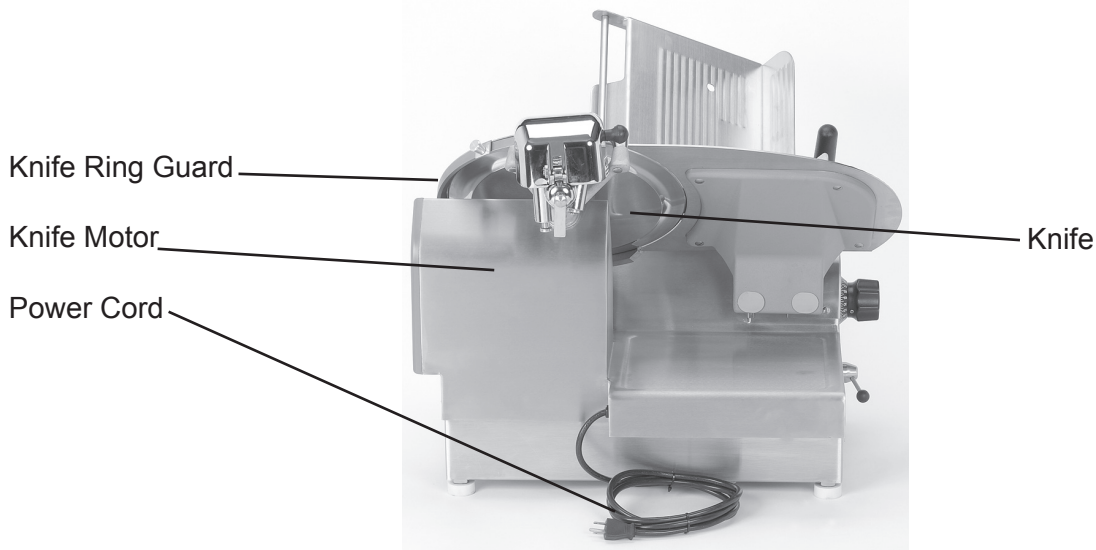
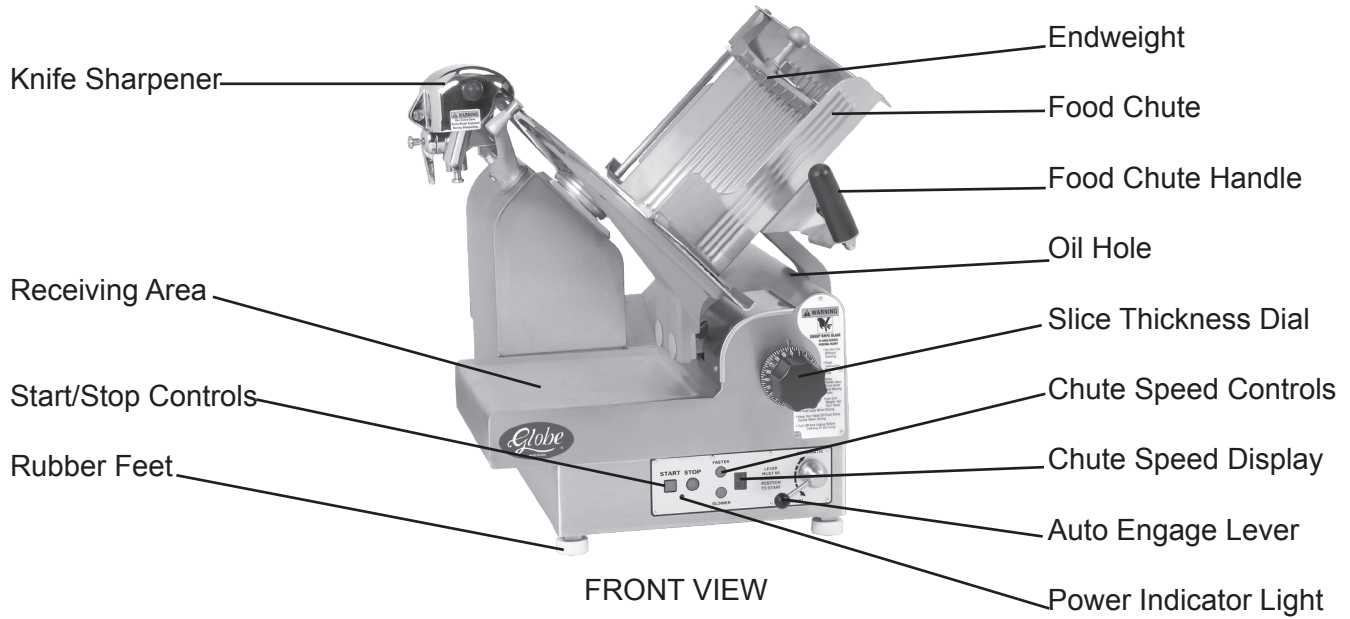

GLOBE SLICER SAFETY TIPS



SHARP KNIFE BLADE

TO AVOID SERIOUS PERSONAL INJURY:

- **NEVER** touch this slicer without training and authorization from your supervisor or if you are under 18 years old. Read the owner and operator manual first.
- **ONLY** install on level nonskid surface that is nonflammable and is located in a clean, well-lighted work area away from children and visitors.
- **ALWAYS** ground slicer utilizing proper power source.
- **NEVER TOUCH KNIFE.** Keep hands and arms away from all moving parts.
- **NEVER OPERATE** slicer without knife cover and knife ring guard securely installed.
- **ONLY USE FOOD CHUTE HANDLE** to push the food chute during manual slicing.
- **ONLY USE THE ENDWEIGHT, NOT YOUR HAND,** to hold food products when slicing. Never put your hand on or around food chute when slicer is on.
- **ALWAYS** turn off slicer, return auto engage lever to “Manual” position, and turn slice thickness dial clockwise past zero until it stops after each use.
- **BEFORE CLEANING, SHARPENING, SERVICING, OR REMOVING ANY PARTS,** always turn slicer off, turn slice thickness dial clockwise to closed position, remove food chute, and unplug power cord.
- **USE ONLY GLOBE SLICER ACCESSORIES** properly installed.

INSTALLATION AND PROPER GROUNDING

UNPACKING:

1. Unpack the slicer immediately after receipt. If the machine is found to be damaged, save the packaging material and contact the carrier within fifteen (15) days of delivery. Immediately contact your source of the equipment. You have no recourse to damage after fifteen (15) days.
2. You should receive with the slicer, rubber feet, Globe oil, warranty card and an owner and operator instruction manual. Contact Globe or your local supplier if you did not receive all of these materials.

WARNING

TO AVOID SERIOUS PERSONAL INJURY PROPERLY INSTALL SLICER IN ADEQUATE WORK AREA

- **ALWAYS** install equipment in work area with adequate light and space.
- **ONLY** operate on a solid, level, nonskid surface that is nonflammable.
- **NEVER** bypass, alter, or modify this equipment in any way from its original condition. Doing so may create hazards and will void warranty.
- **NEVER** operate slicer without knife cover and knife ring guard securely installed.
- **NEVER** operate without all warnings attached and Globe warning card posted.

INSTALLATION:

1. Read this manual thoroughly before installation and operation. **DO NOT** proceed with installation and operation if you have any questions or do not understand anything in the manual. Contact your local representative or Globe **first**.
2. Remove the slicer from the corrugated box.
3. Attach rubber feet to slicer base, making sure they are firmly tightened.



NEVER USE SLICER WITHOUT RUBBER FEET INSTALLED.

4. Select location for slicer that has a level, solid, nonskid surface that is nonflammable and is in a well-lighted work area away from children and visitors.
5. Using a drill and 3/16 drill bit install the white nylon foot retainers onto the counter where the slicer will be sitting.
6. The foot retainers should be located at the back two feet of the slicer. The two back feet should fit securely in the foot retainers to prevent the machine from sliding.



**USE AT LEAST TWO PEOPLE TO LIFT SLICER UP TO OPERATING LOCATION.
NEVER ATTEMPT TO LIFT SLICER ALONE.**

7. Make sure the slicer is level. If the slicer wobbles/rocks once it has been placed on the table or counter adjust the rubber feet until the slicer is level.

INSTALLATION AND PROPER GROUNDING



THIS MACHINE IS PROVIDED WITH A THREE-PRONG GROUNDING PLUG. THE OUTLET TO WHICH THIS PLUG IS CONNECTED MUST BE PROPERLY GROUNDED. IF THE RECEPTACLE IS NOT THE PROPER GROUNDING TYPE, CONTACT AN ELECTRICIAN. DO NOT UNDER ANY CIRCUMSTANCES CUT OR REMOVE THE THIRD GROUND PRONG FROM THE POWER CORD OR USE ANY ADAPTER PLUG (Fig. 7-1 and Fig. 7-2).

8. Inspect slicer to ensure all parts have been provided.
9. Make sure knife cover, knife ring guard, and knife sharpener cover are in place.
10. Make sure warning labels are properly positioned and legible and owners manual is available near slicer. Place the Spanish labels on the slicer if your work force requires them.
11. Complete warranty card and mail to Globe factory.
12. Clean the slicer using the procedures outlined in the cleaning section (pages 10 through 12) prior to using the slicer.
13. Contact your local representative or Globe directly if you have any questions or problems with the installation or operation of this slicer.



Figure 7-1 Correct



Figure 7-2 Incorrect

OPERATING INSTRUCTIONS



SHARP KNIFE BLADE

TO AVOID SERIOUS PERSONAL INJURY:

- **NEVER** touch this slicer without training and authorization from your supervisor or if you are under 18 years old. Read the owner and operator manual first.
- **NEVER TOUCH KNIFE.** Keep hands and arms away from all moving parts.
- **NEVER OPERATE** slicer without knife cover and knife ring guard securely installed.
- **ONLY USE FOOD CHUTE HANDLE** to push the food chute during manual slicing.
- **BE ALERT** that the food chute moves back and forth during automatic operation and can move in either direction on start up.
- **ONLY USE THE ENDWEIGHT, NOT YOUR HAND,** to hold food products when slicing. Never put your hand on or around food chute when slicer is on.
- **ALWAYS** turn off slicer, return auto engage lever to “Manual” position, and turn slice thickness dial clockwise past zero until it stops after each use.
- **BEFORE CLEANING, SHARPENING, SERVICING, OR REMOVING ANY PARTS,** always turn slicer off, turn slice thickness dial clockwise to closed position, remove food chute, and unplug power cord.

MANUAL USE OF AUTOMATIC SLICER (only for slicing ham, turkey, tomatoes, and onions)

1. Automatic slicers can be used manually when slicing any of the items listed above (NOT beef).
2. When manually operating an automatic slicer the auto engage lever **MUST** be in the “Manual” position before turning the slicer on. The lever should not be moved out of the “Manual” position at any time during use.
3. Pull the food chute completely towards you.
4. Turn the slicer on by pressing the start button.
NOTE: If the slicer does not start and there is a flashing 4, the food chute is not in the home position. Pull the food chute completely towards you and restart the slicer.

NOTE: If the slicer does not start and there is a flashing 2, the knife cover is not on or on correctly. Make sure the knife cover is securely in place and restart the slicer.

OPERATING INSTRUCTIONS

WARNING



AUTOMATIC SLICER OPERATION

 **Automatic slicer operation: NEVER put hand into chute arm opening on right side of slicer. Keep hands and arms away from all moving parts.**

1. Pull the food chute completely towards you and load the product onto the chute. Move the end weight to its resting position. Note: The pin on the endweight goes into the hole on the food chute.
2. Place the product onto the food chute and then set the endweight against the product.
3. Rotate the slice thickness dial counter clockwise to the desired setting. If you happen to go past the desired setting you must first rotate the slice thickness dial clockwise past zero “0” and then rotate the dial back to the desired slice thickness setting. After slicing is complete, always turn the slice thickness dial clockwise past zero “0” until it stops to close the slicer table.
4. Move the auto engage lever into the “Automatic” position.

 **BE ALERT. The next step will cause the food chute to move automatically and it can move either direction on start up.**

 **NEVER attempt to adjust, load or unload food chute when slicer is in automatic operation.**

5. Press the start button. The power indicator light will illuminate.

NOTE: If the slicer does not start and there is a flashing 4, the food chute is not in the home position. Pull the food chute completely towards you and restart the slicer.

NOTE: If the slicer does not start and there is a flashing 2, the knife cover is not on or on correctly. Make sure the knife cover is securely in place and restart the slicer.

6. To adjust the chute speed press the slower or faster buttons. The slicer defaults to speed 5 when the power cord is unplugged and plugged back in. If the slicer is turned off but not unplugged, it will return to the last speed used.
7. When you are finished slicing press the stop button. The food chute will return to the home position.
8. Turn the slice thickness dial clockwise past zero until it stops. Note: The dial will bounce back some. Make sure the food chute is completely towards the operator.
9. Remove the product from the food chute.

 For your safety, when changing product, turn the slicer off, make sure the food chute is in the home position and close the slicer table.

CLEANING

WARNING



SHARP KNIFE BLADE

TO AVOID SERIOUS PERSONAL INJURY:

- **BEFORE CLEANING, SHARPENING, SERVICING, OR REMOVING ANY PARTS**, always turn slicer off, turn slice thickness dial clockwise to closed position, remove food chute, and unplug power cord.
- **NEVER** attempt to clean slicer with the knife running.
- **NEVER** attempt to remove the knife or knife ring guard for cleaning.
- **IMPORTANT:** Per Arby's® Corporate, disassembly, cleaning, and sanitizing of the slicer will need to be completed at a minimum of every 4 hours.



Mesh gloves MUST be worn during the entire cleaning procedure!

DISASSEMBLY & CLEANING

Spring Loaded Knob

1. Put the wire mesh gloves on and adjust the straps so they fit securely on your hands. Turn the slicer off.
2. Turn the slice thickness dial clockwise past zero until it stops so the table covers the knife edge. Note: The dial will bounce back some.
3. Push down on the auto engage lever so it is in the "Manual" position.
4. Remove the food chute by loosening the food chute release knob that fastens the food chute to the chute arm. Lift the food chute off the chute arm and take the chute back to the sink for cleaning.
5. Unplug the power cord.



Figure 10-1

BE ALERT. The next steps will expose the knife.

6. Lift the knife sharpener cover.
7. To remove the knife cover hold the top spring-loaded knob with your right hand and with your left hand hold the bottom knob. Pull up on the spring-loaded knob and lift the knife cover upward to remove. Take the knife cover back to the sink for cleaning.



Figure 10-2

CLEANING

⚠ CAUTION

- **IMPORTANT:** Per Arby's® Corporate, disassembly, cleaning, and sanitizing of the slicer will need to be completed at a minimum of every 4 hours.
- **DO NOT** put components in dishwasher.
- **DO NOT** hose down, pressure wash, or pour water on the slicer.
- **NEVER** use scrubber pad, steel wool, or abrasive material to clean the slicer.
- **NEVER** remove sharpener from slicer or immerse in water.
- Clean the disassembled components with a mild detergent and warm water solution. Allow parts to air dry.
- **USE ONLY** Arby's® specified sanitizers from P & G or Damon.
- **DO NOT** use bleach or other caustic/strong detergents on the slicer base or components.
- Dilute detergent per supplier's instruction. Products containing sodium hypochlorite should not be used on the slicer.

⚠ **NEVER** try to clean, sharpen, or operate slicer with the lift lever in the raised position .

⚠ **ALWAYS** turn off slicer and unplug power cord **BEFORE** cleaning.

8. To clean the knife ring guard, insert a nylon brush into a mild detergent and warm water solution. Work the brush along the outer edge of the knife. Also work the brush along the entire back side of the knife. Repeat both procedures using a nylon brush inserted into the Arby's® specified sanitizer.



Figure 11-1

⚠ **CAUTION** **DO NOT** allow moisture to get into knife hub.

9. Next insert a handy wipe in a mild detergent, warm water solution. Ring out excess water and carefully wipe the knife from the center of the knife outward. Also wipe the slicer table by starting at the knife and wiping away from the blade. Make sure that you clean the back of the knife as well. Repeat this entire process with another handy wipe that is inserted into the Arby's® specified sanitizer with the excess solution being ringed out.



Figure 11-2

10. Retrieve the cleaned, sanitized, and dry knife cover from the sink area and align the notches of the knife cover with the knobs located on the knife ring guard. The top of the knife cover has a hole that fits over a pin at the top of the ring guard.



Figure 11-3

11. Lower the knife sharpener cover.
12. Using the Arby's® approved sanitizer, spray and wipe down the entire slicer.

CLEANING

REASSEMBLY

1. The slicer has a lift lever that raises it to allow cleaning underneath.
 - a. With the auto engage lever in the “Manual” position push the chute arm to the back of the slicer.
 - b. Pull the lift lever knob towards you with your right hand while gently lifting up on the slice thickness dial with the other (Fig. 12-1).
 - c. Pull the lift lever towards you until it stops (Fig. 12-2).



Hold the lift lever with one hand while you clean the counter area under the slicer.

2. After cleaning the counter area under the slicer gently lower the slicer back to its operating position. Make sure the slicer feet are in the foot retainers.
3. Retrieve the cleaned, sanitized, and dried food chute from the sink area and place it back onto the chute arm. Securely tighten the food chute release knob.
4. Plug the slicer in.

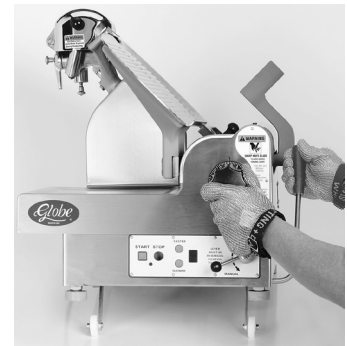

Figure 12-1



Figure 12-2

KNIFE SHARPENING

WARNING



SHARP KNIFE BLADE

TO AVOID SERIOUS PERSONAL INJURY:

- **NEVER** touch rotating knife.
- **ALWAYS** keep hands clear of all moving parts.
- **ALWAYS** turn off slicer, return auto engage lever to “Manual” position, turn slice thickness dial clockwise past zero until it stops, and remove food chute before sharpening.
- **NEVER** sharpen slicer unless all guards are installed.
- **ALWAYS** make sure food chute is removed and auto engage lever is in “Manual” position when sharpening.

IMPORTANT GENERAL NOTES

1. Symptoms of a dull knife are excess waste/or a “tail” on the unsliced portion remaining in the food chute.
2. The knife needs to be sharpened periodically to provide consistent slices and maximum food product yield. Sharpening the knife lightly every few days is more efficient than heavy sharpening at less frequent intervals.
3. The sharpening stones are diamond grit and sharpen more quickly and aggressively than in the past!
4. Over sharpening will prematurely wear out the knife.

PREPARING TO SHARPEN



Turn slicer off by pressing the stop button.



Make sure auto engage lever is in the “Manual” position.

1. Turn the slice thickness dial clockwise past zero until it stops so the slicer table covers knife edge.
2. Remove the food chute from slicer.
3. Clean and dry both sides of the knife before sharpening following instructions for knife cleaning on pages 10 through 12.

NOTE: The knife cover must be on during sharpening. The slicer will not start if the knife cover is removed.

KNIFE SHARPENING

⚠ BE ALERT. The next steps will expose the knife.

4. Lift the sharpener cover to expose the sharpening stones (Fig. 14-1).
5. Use a dry wire brush and aggressively brush the top grinding surface of the grinding stone, which will remove debris from the stones, grit, especially the grinding stone (Fig. 14-2). **This procedure is very important.**

⚠ ALWAYS keep hands and arms away from exposed knife.

SHARPENING THE KNIFE - (REGULAR PROCEDURE)

The knife should be sharpened every TWO days for 5 seconds.

1. Pull on knob #1 (Fig. 14-3) keeping it extended and swinging the sharpener up into position. Release knob and the sharpener will lock in the sharpening position.
2. Pull out knob #2 (Fig. 14-4).
3. Turn the knife motor on by pressing the start button. Pull the lever counterclockwise (Fig. 14-5) to bring stones into contact with the knife. Maintain pressure on the lever for 5 seconds. Be sure both stones are rotating and are in contact with knife.

⚠ TURN OFF slicer before inspecting.

SHARPENING THE KNIFE - (EXTENDED PROCEDURE)

IMPORTANT: If you are not getting the proper slice count or you are getting excess waste/or a “tail” on the unsliced portion remaining in the food chute follow the extended sharpening procedures below.

1. Pull on knob #1 (Fig. 14-3) keeping it extended and swinging the sharpener up into position. Release knob and the sharpener will lock in the sharpening position.
2. Activate only the bottom stone by pushing in knob #2.
3. Turn the knife motor on by pressing the start button. Pull the lever counterclockwise (Fig. 14-5) to bring the grinding stone (located behind the blade) into contact with the knife. Maintain pressure on the lever for 30 seconds.
4. Pull out knob #2. Pull the lever counterclockwise to bring both stones into contact with the blade. Maintain pressure on the lever so both stones rotate for 5 seconds.

⚠ TURN OFF slicer before inspecting.



Figure 14-1



Figure 14-2



Figure 14-3

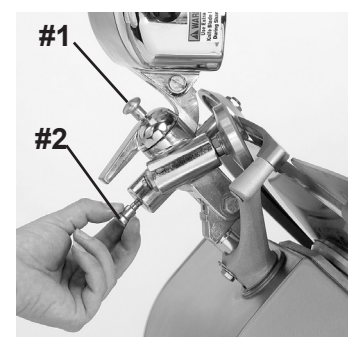

Figure 14-4



Figure 14-5

KNIFE SHARPENING

FINISH SHARPENING

When sharpening is finished, follow these procedures:

1. Turn the slicer off by pressing the stop button. Unplug the power cord.
2. Return the sharpener to its original position by pulling on knob #1 (Fig. 15-1) keeping it extended and swinging sharpener back to its stored position.
3. Clean the sharpening stones with soapy water and a brush. Dry stones afterwards.
4. Close the sharpener cover.
5. Clean the slicer as necessary using cleaning procedures listed on pages 10 through 12.
6. Plug in power cord.
7. Reinstall the food chute on the slicer.



Figure 15-1

SIMPLE MAINTENANCE AND REPAIR

WARNING



SHARP KNIFE BLADE

TO AVOID SERIOUS PERSONAL INJURY:

- **BEFORE CLEANING, SHARPENING, SERVICING, OR REMOVING ANY PARTS**, always turn slicer off, turn slice thickness dial clockwise to closed position, remove food chute, and unplug power cord.
- **NEVER TOUCH KNIFE.** Keep hands and arms away from all moving parts.
- **DO NOT** tamper with, bypass, or remove any safety devices, guards, or touch pad controls.
- **ALWAYS** turn off slicer, return auto engage lever to “Manual” position, and turn slice thickness dial clockwise past zero until it stops after each use.
- **USE ONLY GLOBE PARTS AND ACCESSORIES** properly installed.

LUBRICATION

Various slicer parts need to be lubricated periodically using Globe oil. Globe oil is a light, tasteless odorless mineral oil that will not contaminate or impart odors or taste to sliced food product.

CAUTION

DO NOT USE VEGETABLE OIL TO LUBRICATE SLICER. VEGETABLE OIL WILL DAMAGE THE SLICER.

Food Chute Slide Rods

It is necessary to lubricate the food chute slide rods with Globe oil weekly or when excessive drag is felt.

1. Close slicer table. Make sure the auto engage lever is in the “Manual” position.
2. Remove the food chute from the chute arm.
3. Pull the food chute arm completely forward and hold in position so the oil hole is located behind the chute arm.
4. Remove cap from the oil container. Add several drops of Globe oil into the oil hole (Fig. 16-1).
5. Wipe off excess oil.
6. Move the food chute back and forth to distribute the oil.
7. Reinstall the food chute.



Figure 16-1

SIMPLE MAINTENANCE AND REPAIR

Endweight Slide Rod

The endweight slide rod should be lubricated weekly or when excessive drag is felt with a few drops of Globe oil.

1. Add a few drops of Globe oil to the slide rod (Fig. 17-1).
2. Slide the endweight up and down several times to distribute the oil.

Slide Rod

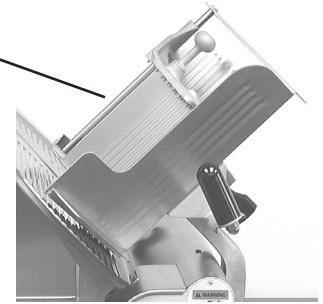

Figure 17-1

Sharpener

It is necessary to lubricate the sharpener shafts with Globe oil once per month.

1. Raise the sharpener cover.
2. Raise the sharpener up into position.
3. Pull up on the sharpener knob and place a couple drops of Globe oil on the shaft (Fig. 17-2).
4. Lower the sharpener back to its original position.
5. Pull up on the honing stone and put a couple drops of Globe oil on the shaft (Fig. 17-3).
6. Move the stone up and down a couple of times to distribute the oil.
7. Pull the lever counterclockwise and hold it in that position while you place a couple drops of Globe oil on the other sharpener shafts (Fig. 17-4 and Fig. 17-5).
8. Move the lever back and forth several times to distribute the oil.
9. Wipe off any excess oil.
10. Close the sharpener cover.
11. Wipe off any excess oil that might have gotten on the slicer.



Figure 17-2

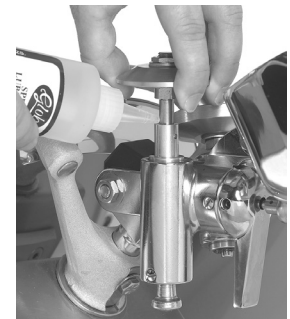

Figure 17-3



Figure 17-4



Figure 17-5

Lever

OPTIMAL SLICING PERFORMANCE

TO OBTAIN THE MAXIMUM PERFORMANCE AND YIELD FROM YOUR GLOBE SLICER:

1. Read this entire manual before touching slicer and strictly follow all instructions and precautions. **THERE IS NO SUBSTITUTE FOR SAFETY!**
2. Lubricate the slicer per the instructions on pages 16 and 17.
3. Maintain a sharp knife and replace as necessary. Refer to the knife sharpening procedure on pages 13 through 15. Globe recommends replacing the knife at approximately 12" diameter. Never attempt to replace the knife yourself. Contact an authorized Globe service company to replace the knife.
4. Clean knife prior to sharpening slicer per the instructions on pages 10 through 12.
5. As the knife is sharpened and the diameter is reduced, it will be necessary to have:
 - a. The table adjusted inward toward the knife in order to maintain a consistent 1/16" clearance between the table and knife.
 - b. The sharpener assembly adjusted lower to maintain proper alignment with the knife.

**We recommend an authorized Globe service company
perform all adjustments and preventive maintenance
(See front cover for service contact information).**

**By adequately maintaining your slicer, it will provide years of dependable
service. The only way to damage a Globe slicer is by neglect.**

SERVICE AND TROUBLESHOOTING GUIDE

SYMPTOM	CAUSE	SOLUTION
Slicer will not start	Slicer not plugged in Breaker at panel tripped Knife cover off	Plug in slicer Reset breaker at power box Install knife cover
Chute speed light flashing a 3	Chute motor overload. Check for obstructions and lubrication	Clear obstructions, lube rails, unplug slicer for 10 seconds, plug slicer in and restart
Chute speed light flashing a 4	Food chute not in home position	Pull chute towards you and restart the slicer
Chute speed light flashing a 2	Knife cover off	Install knife cover
Ragged cuts-poor yield	Dull knife Chipped knife Knife-slicer table gap too wide Knife too small, 12" or less	Sharpen knife-make sure knife and stones are clean Sharpen or have new knife installed Call for service to adjust slicer table Have new knife installed
Metal rubbing knife	Knife cover Food chute Endweight Slicer table	Make sure knife cover is securely installed Tighten or adjust food chute Have defective endweight replaced Call for service to adjust slicer table
Table will not operate	Knife cover off	Install knife cover
Hard to push food chute	No lubrication	Lubricate slide rods thoroughly with Globe oil. No vegetable oil!
Hard to sharpen	Stones dirty, wet or clogged with grease Knife dirty Worn stones Stones not properly aligned	Clean stones with soapy water and brush. Dry stones afterwards. Clean top and bottom of knife Have stones replaced Have sharpener adjusted

LIMITED WARRANTY

Globe Food Equipment Company ("GFE") warrants to the original purchaser of new equipment that said equipment, when installed in accordance with our instructions within North America and subjected to normal use, is free from defects in material or workmanship for a period of 1 year on parts (excludes wear/expendable parts). The labor warranty is 1 year on labor from original installation, or 18 months from actual shipment date, whichever date occurs first. The labor warranty includes travel within a 50 mile radius of the authorized service center during normal business hours (M-F, 8am-5pm). The motor pinion gear and knife drive gear have a 15 year limited warranty.

NOTE: There is also an extended service program available for purchase, which is 3 years on parts (excludes wear/expendable parts). The labor warranty is 3 years on labor from original installation, or 42 months from actual shipment date, whichever date occurs first. The labor warranty includes travel within a 50 mile radius of the authorized service center during normal business hours (M-F, 8am-5pm). 2 preventative maintenance calls per year is also included in this service program.

THIS WARRANTY IS IN LIEU OF ALL OTHER WARRANTIES, WHETHER EXPRESSED OR IMPLIED. GFE EXPRESSLY DISCLAIMS ANY IMPLIED WARRANTY OF MERCHANTABILITY OR EXPRESS OR IMPLIED WARRANTY OF FITNESS FOR A PARTICULAR PURPOSE.

GFE'S OBLIGATION AND LIABILITY UNDER THIS WARRANTY IS EXPRESSLY LIMITED TO REPAIRING AND REPLACING EQUIPMENT WHICH PROVES TO BE DEFECTIVE IN MATERIAL OR WORKMANSHIP WITHIN THE APPLICABLE WARRANTY PERIOD. All repairs pursuant to this Warranty will be performed by an Authorized Designated GFE Service Location during normal working hours. IN NO EVENT SHALL GFE BE LIABLE FOR INCIDENTAL OR CONSEQUENTIAL DAMAGES TO BUYER OR ANY THIRD PARTY, INCLUDING, WITHOUT LIMITATION, LOSS OF PROPERTY, PERSONAL INJURY, LOSS OF BUSINESS OR PROFITS OR OTHER ECONOMIC LOSSES, OR STATUTORY OR EXEMPLARY DAMAGES, WHETHER IN NEGLIGENCE, WARRANTY, STRICT LIABILITY, OR OTHERWISE. CUSTOMER WILL PAY \$75.00 FOR ANY LABOR ONLY CALLS PLACED TO SERVICE AGENT.

This Warranty is given only to the first purchaser from a retail dealer. No warranty is given to subsequent transferees.

This Warranty does not cover product failures caused by: failure to maintain, neglect, abuse, damage due to excess water, fire, normal wear, improper set up and use. Periodic maintenance including lubrication and sharpening are not covered.

This Warranty is not in force until such time as a properly completed and signed Installation/Warranty Registration has been received by GFE within 30 days from the date of installation.

THE FOREGOING WARRANTY PROVISIONS ARE A COMPLETE AND EXCLUSIVE STATEMENT BETWEEN THE BUYER AND SELLER. GFE NEITHER ASSUMES NOR AUTHORIZES ANY PERSONS TO ASSUME FOR IT ANY OTHER OBLIGATION OR LIABILITY IN CONNECTION WITH SAID EQUIPMENT.

Example of items not covered under warranty, but not limited to just these items:

1. Acts of God, fire, water damage, burglary, accident, theft.
2. Freight damage.
3. Improper installation or alteration of equipment.
4. Use of generic or after market parts.
5. Repairs made by anyone other than a GFE designated servicer.
6. Lubrication.
7. Expendable wear parts.
8. Cleaning of equipment.
9. Misuse or abuse.