

Parts Catalogue Protech Series



Protech Model 4500

Globe

PROTECH SLICING MACHINES

MODELS: 4500, 4750, 4875V

IMPORTANT!

TO EXPEDITE SHIPMENT OF PARTS, ALWAYS SPECIFY MODEL AND PART NUMBER, AND WHEN AVAILABLE, SERIAL NUMBER OF SLICER.

GLOBE FOOD EQUIPMENT COMPANY

3506 Encrete Lane
Dayton, Ohio 45439

Parts Department

Toll Free 1-800-745-6238

Fax (937) 290-0585

E-Mail: globeinfo@globe-food.com

Visit our web page at: www.globe-food.com

TABLE OF CONTENTS

ASSEMBLIES	1
BASE	2
BASE SHROUD AND COMPONENTS	3
TABLE	4
SLIDE SYSTEM	5
TABLE ADJUSTMENT COMPONENTS	7
GEAR HOUSING AND KNIFE	9
MOTORS AND AUTOMATIC MOTOR BASE	11
KNIFE MOTOR HARDWARE	12
KNIFE PLATE	13
KNIFE COVER AND RIM GUARD	15
SHARPENER	17
STAINLESS STEEL CHUTE AND SUPPORT	19
ENDWEIGHTS	20
SLICE DEFLECTOR AND PIN	21
QUICK RELEASE AUTOMATIC CHAIN SLIDE	22
AUTOMATIC BASE APRON AND CHAIN GUARD	23
LIFT LEVER SYSTEM	24
AUTOMATIC CHUTE DRIVE SYSTEM	25
FRONT MOUNTED END WEIGHT CHUTE ASSEMBLY	26
ELECTRICAL COMPONENTS AND HARDWARE	27
WIRING HARNESS AND COMPONENTS	29
PRINTED CIRCUIT BOARDS AND HARDWARE	31
VEGETABLE HOPPER ACCESSORY	32
CHUTE FENCES ACCESSORY	33
TOOL LIST	34

ASSEMBLIES

ASSEMBLY DESCRIPTION	PART NUMBER
Sharpener Assembly Without Cover	10-A-1
Sharpener Assembly With Cover	450-H-AS
Stainless Steel Chute 12" Includes End Weight Without Prongs	102-AS-12
Stainless Steel Chute 12" Includes End Weight With Prongs	102-AS-13
Knife Cover Assembly	972-C-AS
Knife Plate Assembly - Bronze Gear	972-P-AS-1
Knife Plate Assembly - Nylon Gear	972-P-AS-2
Slide and Bushing Assembly	991-1B-AS
64 Link Slide Drive Chain Assembly (Autos Only)	766-2B-AS
Table Assembly	976-AS
Gear Housing Assembly	969-AS
Stainless Steel End Weight Assembly Without Prongs	741-SS-AS
Stainless Steel End Weight Assembly With Prongs	741-SS-APC
Automatic Main Switch Assembly (Without Boot)	952-10
Automatic Chain Slide Assembly	974-AS
Table adjusting Gear Assembly	453-AS

ACCESSORIES



VEGETABLE HOPPER



ADJUSTABLE STAINLESS
STEEL FOOD FENCES



FRONT MOUNTED ENDWEIGHT
AND CHUTE ASSEMBLY

DESCRIPTION	PART NUMBER
VEGETABLE HOPPER (CYLINDER CHUTE)	699-EAS
FENCE SHORT-HIGH 12" x 3" HIGH	940-FSH
FENCE SHORT-LOW 12" x 1 3/8" HIGH	940-FSL
FENCE LONG-HIGH 17" x 3" HIGH	940-FLH
FENCE LONG-LOW 17" x 1 3/8" HIGH	940-FLL
STAINLESS STEEL CHUTE 17" INCLUDES END WEIGHT WITH PRONGS	102-AS-14
TWIN CYLINDER CHUTE ASSEMBLY	1001-EAS
FRONT MOUNTED END WEIGHT AND CHUTE ASSEMBLY	102-AS-15

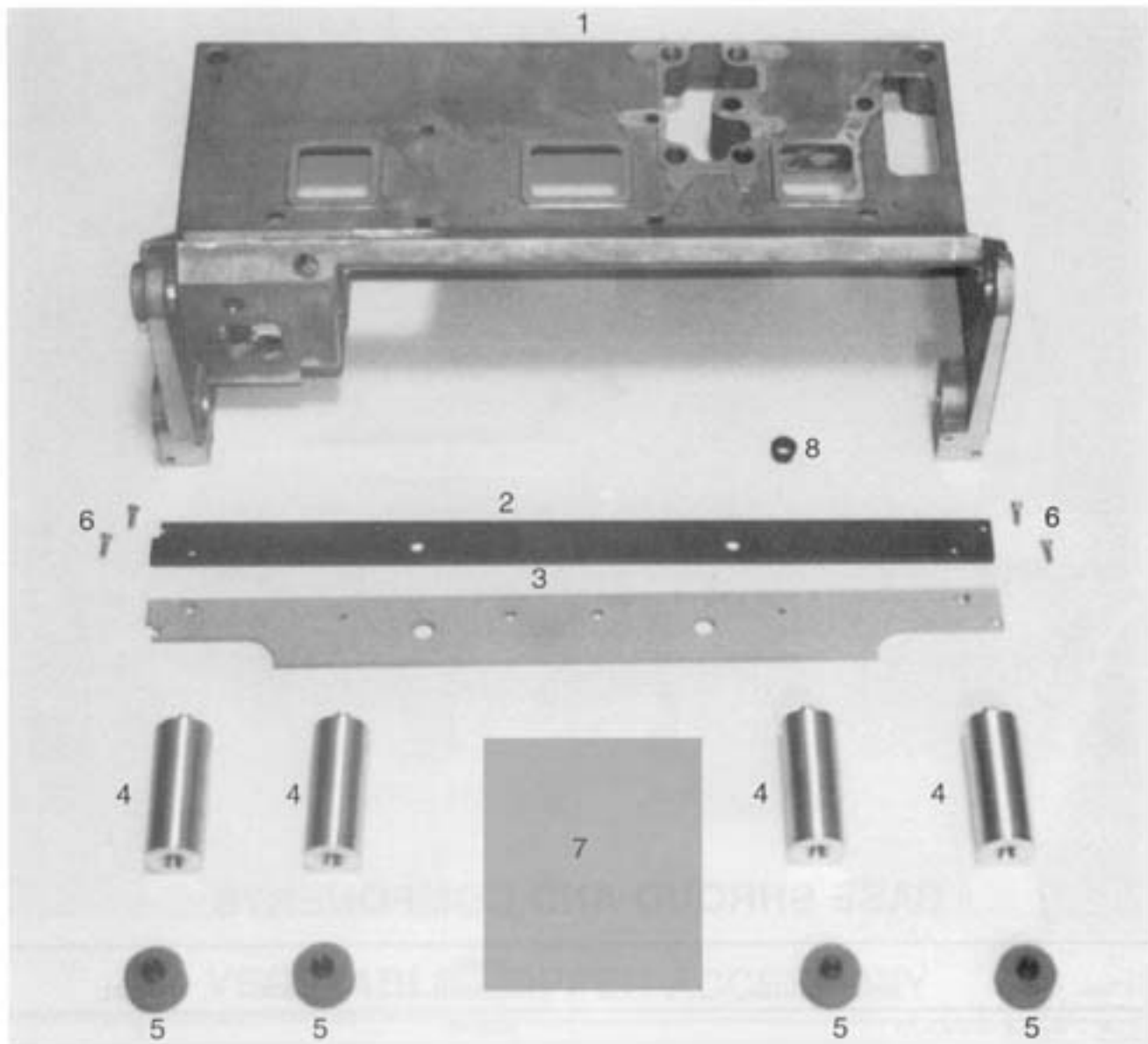

BASE

ITEM	DESCRIPTION	PART NUMBER	AUTO	MANUAL
1	BASE	850-DC-E	X	X
2	BASE SUPPORT RIB	850-1		X
3	SPROCKET STUD MOUNT RIB	987	X	
4	BASE FOOT EXTENSION (4 REQ'D)	873		X
5	BASE PAD RUBBER FOOT (4 REQ'D)	817	X	X
6	RIB SCREW (4 REQ'D)	834-S	X	X
7	BASE SCREEN	850-6	X	X
8	SNAP BUSHING	850-7	X	X

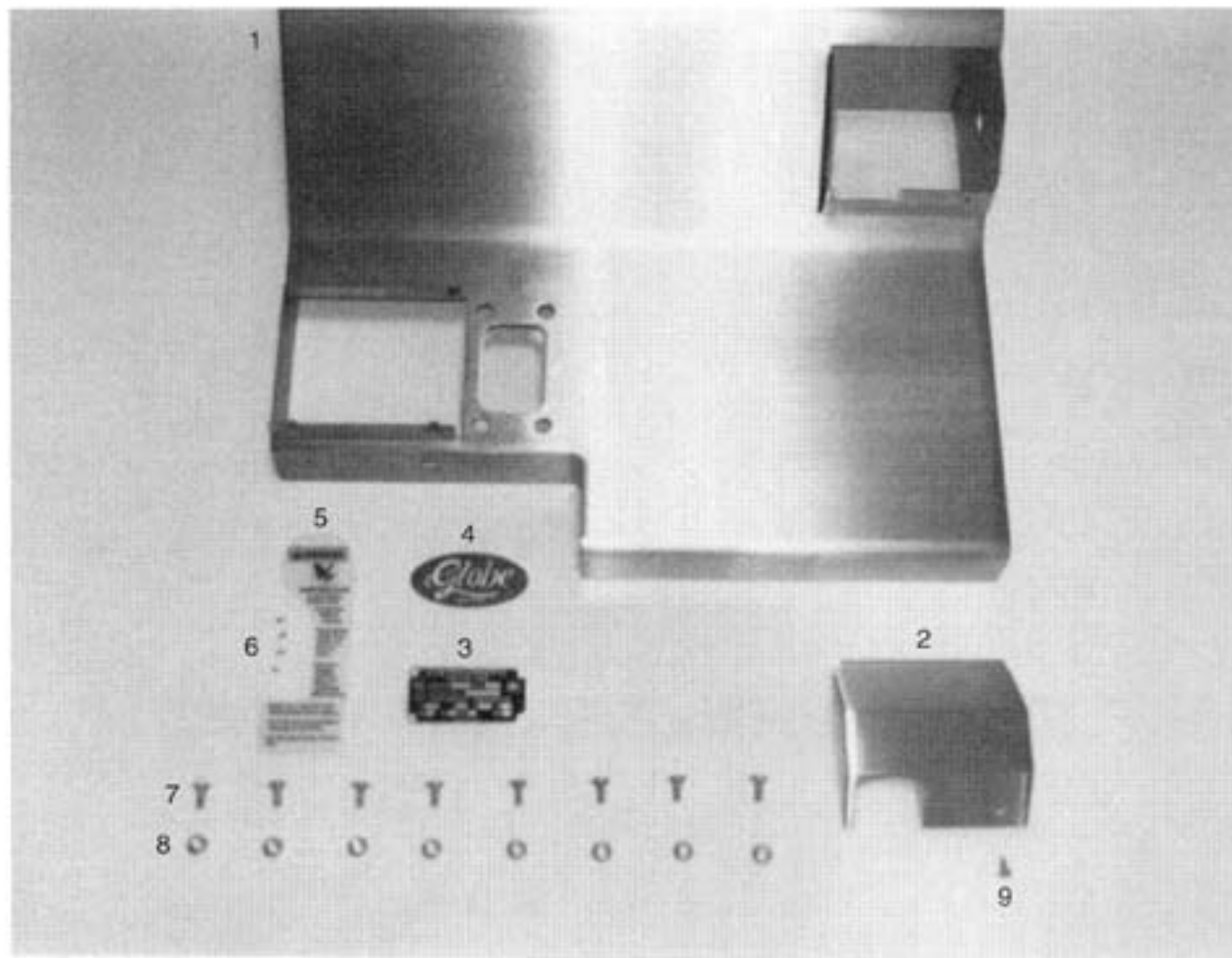

BASE SHROUD AND COMPONENTS

ITEM	DESCRIPTION	PART NUMBER	AUTO	MANUAL
1	BASE SHROUD	953-4F		X
	BASE SHROUD	960-4F	X	
2	TABLE MECHANISM COVER	979	X	X
3	DATE PLATE, BLANK	885-1BLR	X	X
4	GLOBE LOGO DECAL	871-2	X	X
5	WARNING PLATE - ENGLISH	967-1	X	X
	WARNING PLATE - SPANISH	967-1S	X	X
6	DRIVE SCREW (4 REQ'D)	851-6P	X	X
7	BASE SHROUD SCREW (8 REQ'D)	851-1	X	X
8	NUT (8 REQ'D)	851-3FN	X	X
9	SCREW	900-1	X	X

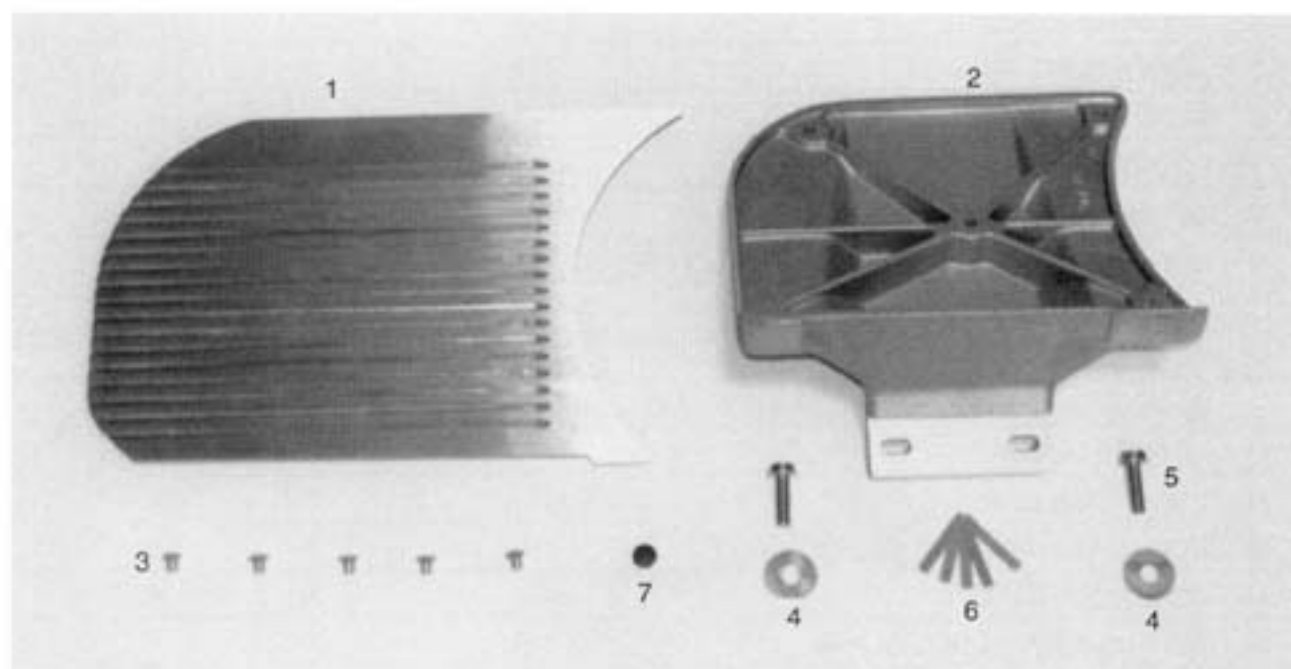
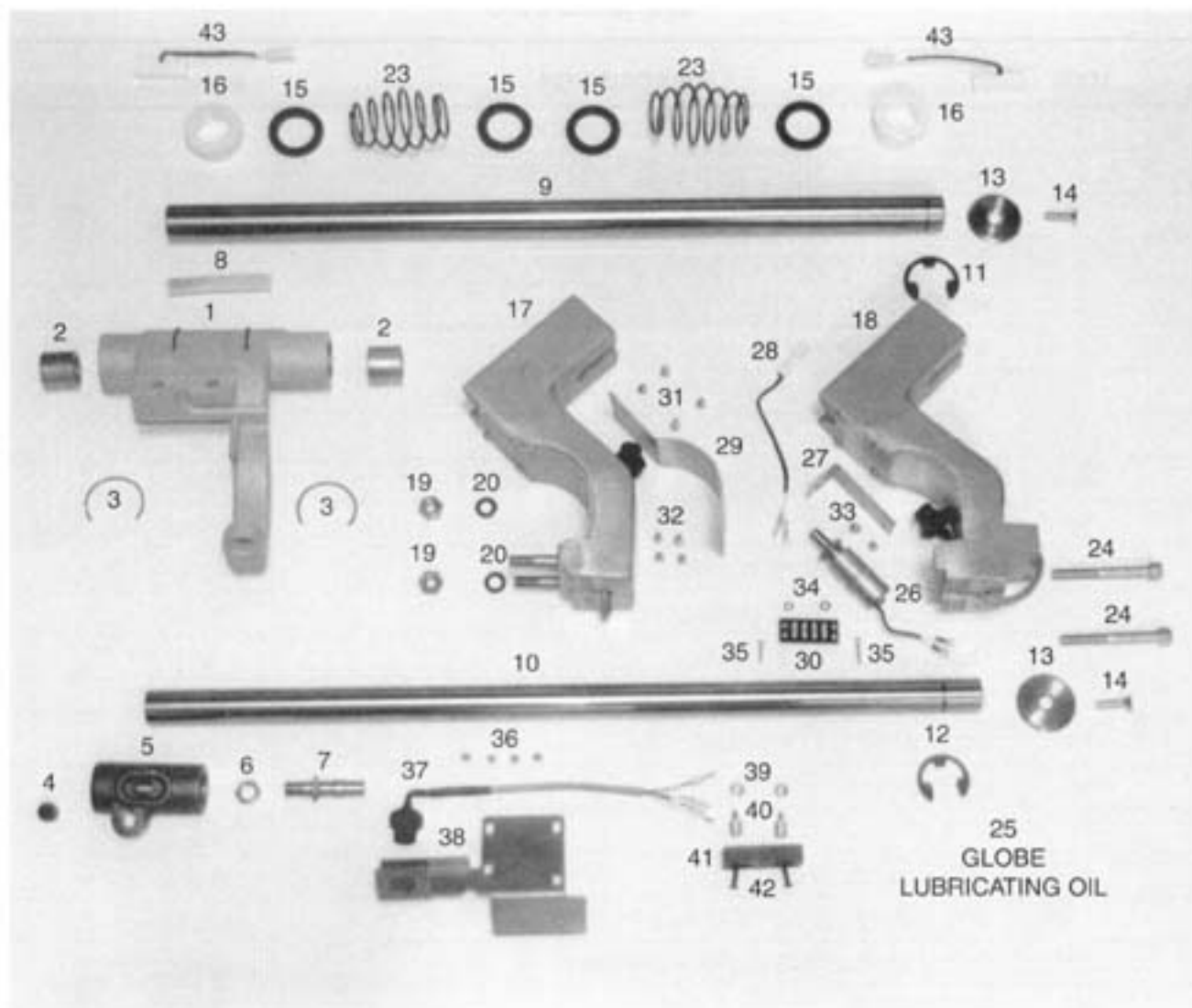

TABLE ALL MODELS

ITEM	DESCRIPTION	PART NUMBER
	TABLE ASSEMBLY	976-AS
1	● TABLE STAINLESS STEEL	976
2	● TABLE SUPPORT	977
3	● TABLE FASTENER (5 REQ'D)	976-1
4	TABLE SCREW WASHER (2 REQ'D)	977-2
5	TABLE SCREW (2 REQ'D)	977-1
6	TABLE SHIMS	337-A
7	HOLE PLUG	850-3

SLIDE SYSTEM

ITEM	DESCRIPTION	PART NUMBER	AUTO	MANUAL
1	UPPER SLIDE	991	X	X
	● OIL TUBE	436-A	X	X
2	● UPPER BUSHING (2 REQ'D)	436-7	X	X
3	SPRING CLIP (2 REQ'D)	436-4	X	X
4	ROUND OIL FELT	170	X	X
5	LOWER BUSHING	449	X	X
6	STUD NUT	228	X	X
7	LOWER BUSHING STUD	241-B	X	X
8	UPPER SLIDE FELT	436-3	X	X
9	SLIDE BAR - UPPER 1"	857	X	X
	SLIDE BAR - UPPER STAINLESS STEEL 1"	857-S	X	X
10	SLIDE BAR - LOWER 7/8"	858	X	X
	SLIDE BAR - LOWER STAINLESS STEEL 7/8"	858-S	X	X
11	UPPER BAR CLIP	857-1	X	X
12	LOWER BAR CLIP	858-1	X	X
13	SLIDE BAR WASHER (2 REQ'D)	859	X	X
14	SCREW (2 REQ'D)	859-1	X	X
15	SLIDE BUMPER (4 REQ'D)	918	X	
16	SLIDE BUMPER (2 REQ'D)	436-1U		X
17	CHUTE RECEIVER	990-M		X
18	CHUTE RECEIVER	990	X	
19	NUT (2 REQ'D)	478-1	X	X
20	LOCK WASHER (2 REQ'D)	245-A	X	X
21	<small>NOT SHOWN</small> CHUTE ADJUST SET SCREW	760-4	X	X
22	<small>NOT SHOWN</small> NUT	760-5	X	X
23	BUMPER SPRING (2 REQ'D)	919-4	X	
24	CAP SCREW (2 REQ'D)	883-2	X	
25	GLOBE LUBRICATING OIL (4 OZ.)	519	X	X
26	CHUTE SOLENOID 24VDC	955-1AS-1	X	X
27	CHUTE SOLENOID BRACKET	990-1	X	X
28	INTERLOCK SWITCH ROUND	995-2AS	X	X
29	CHUTE RECEIVER COVER	990-3	X	X
30	TERMINAL BLOCK	995-24	X	X
31	SCREW (4 REQ'D)	990-6	X	X
32	SCREW (4 REQ'D)	990-6	X	X
33	SCREW (2 REQ'D)	990-6	X	X



SLIDE SYSTEM (CONTINUED)

ITEM	DESCRIPTION	PART NUMBER	AUTO	MANUAL
34	LOCK WASHER (2 REQ'D)	952-22	X	X
35	SCREW 2 (REQ'D)	995-31	X	X
36	SCREW 4 (REQ'D)	990-6	X	X
37	CONNECTOR ASSEMBLY	995-7	X	X
38	MAGNET / CONNECTOR BRACKET	990-2	X	X
39	NUTS (2 REQ'D)	952-23	X	X
40	STANDOFF, MAGNET	990-5	X	X
41	MAGNET	985-1	X	X
42	SCREW 2 (REQ'D)	407-33	X	X
43	INTERLOCK SWITCH, RECTANGLE (2 REQ'D)	995-3AS	X	X

TABLE ADJUSTMENT COMPONENTS

ALL MODELS

ITEM	DESCRIPTION	PART NUMBER
1	TABLE ADJUSTMENT KNOB ASSEMBLY	407-AS
2	ADJUSTMENT KNOB SET SCREW (2 REQ'D)	356-1
3	KNOB SHAFT	864
4	WORM WASHER	359
5	WORM GEAR	358
6	WORM GEAR PIN	360
7	KNOB BALL	362
8	BALL SPRING	361
9	THRUST SCREW	361-1
10	SLIDE GUIDE	349
11	SLIDE GUIDE SCREW (2 REQ'D)	350
12	SLIDE GUIDE SHIM (ASSORTED SIZES)	349-A
13	TABLE SLIDE, CAST IRON	978
14	TABLE SLIDE STOP SCREW	978-1
15	STOP SCREW LOCK NUT	478-1
16	NYLON TIP SET SCREW	168-1
17	NUT	760-5
18	TABLE SLIDE SHAFT	978-2
	TABLE SLIDE SHAFT STAINLESS STEEL	978-2S
19	TABLE ADJUSTING GEAR ASSEMBLY	453-AS
20	SET SCREW	700-3
21	WASHER	756-2
22	HEX SCREW	335
23	TABLE SOLENOID 24VDC	995-1AS-2
24	SWITCH	854-1
25	SCREW	863-1
26	NUT	760-5
27	SCREW (2 REQ'D)	854-2
28	SPACER BLOCK (PLASTIC)	855-1A
29	SCREW	855-3

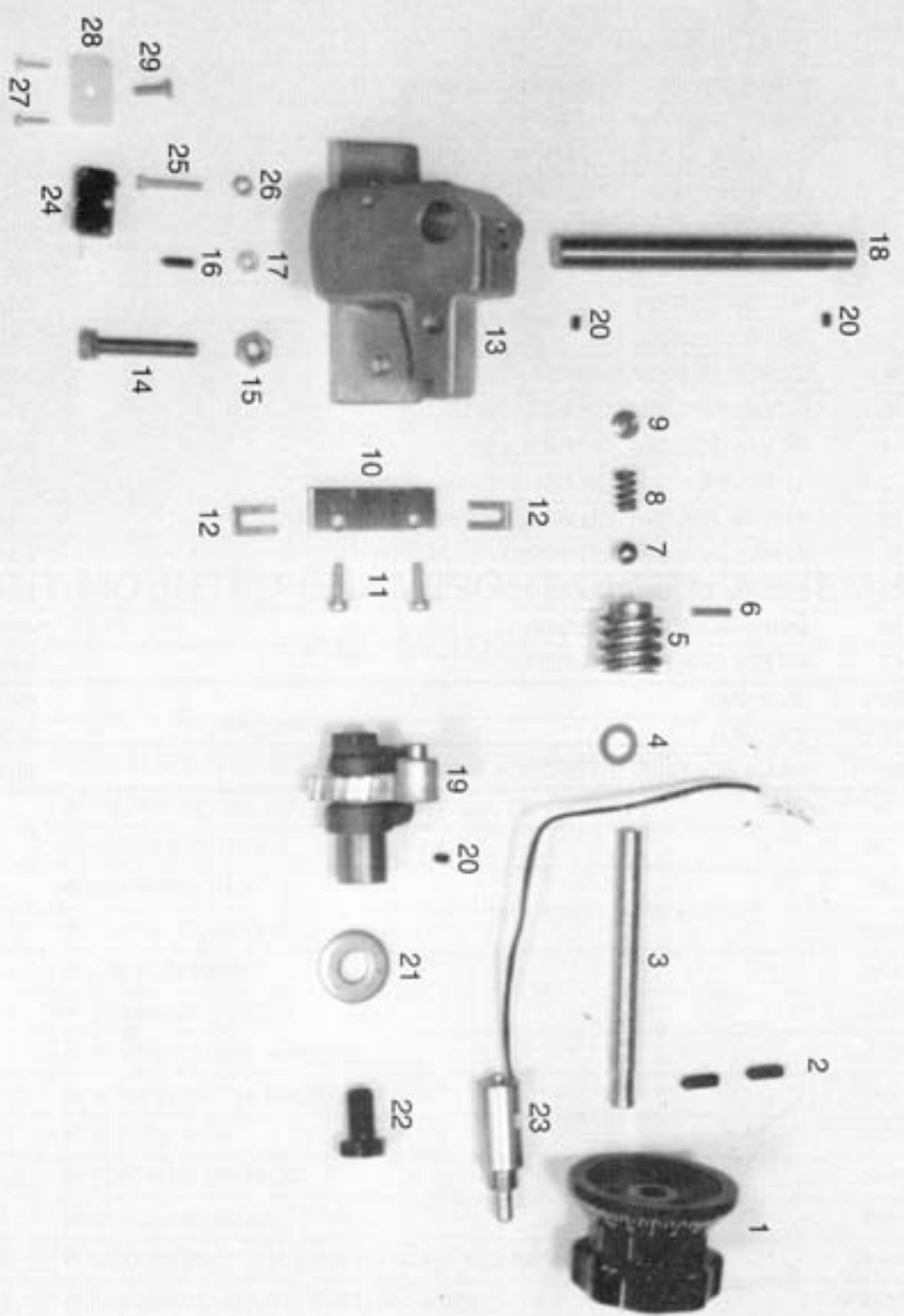

GEAR HOUSING AND KNIFE

ALL MODELS

ITEM	DESCRIPTION	PART NUMBER
	GEAR HOUSING ASSEMBLY	969-AS
1	GEAR HOUSING	969
2	KNIFE, HOLLOW GROUND (CARBON)	963-HC
	KNIFE, HOLLOW GROUND (STAINLESS STEEL)	963-S
3	KNIFE GUARD STUD KNOB ASSEMBLY	879-AS
4	GEAR HOUSING SCREW (4 REQ'D)	369-1
5	GEAR LUBE 140W (QUART)	972-A
6	INTERLOCK SWITCH PLUNGER	854-8
7	MOTOR SCREW 3 1/2"	969-1
8	GEAR HOUSING FELT	370
9	MOTOR SCREW (2 REQ'D)	795-S
10	INTERLOCK SWITCH INSULATOR	854-4
11	INTERLOCK SWITCH BRACKET	854-5
12	INTERLOCK SWITCH SCREW WASHER (2 REQ'D)	854-7
13	INTERLOCK SWITCH BRACKET SCREW (2 REQ'D)	854-6
14	INTERLOCK SWITCH SCREW (2 REQ'D)	854-2
15	INTERLOCK SWITCH SCREW NUT (2 REQ'D)	854-3
16	KNIFE SCREW (6 REQ'D)	747-15S
17	INTERLOCK RETAINER STUD	879-5
18	BUSHING	850-5
19	WASHER	763-4A
20	GEAR HOUSING INTERLOCK SWITCH	854-1

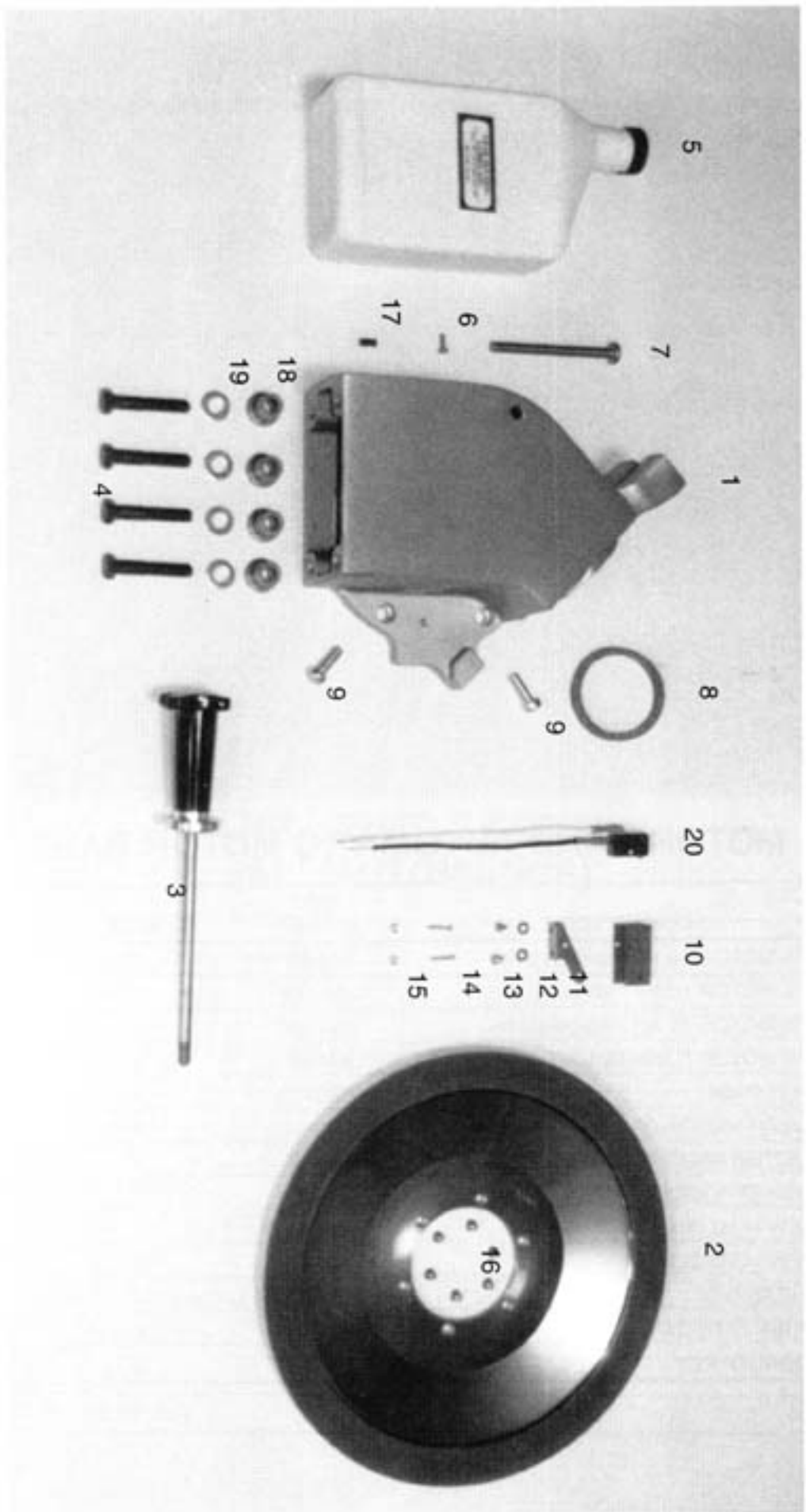

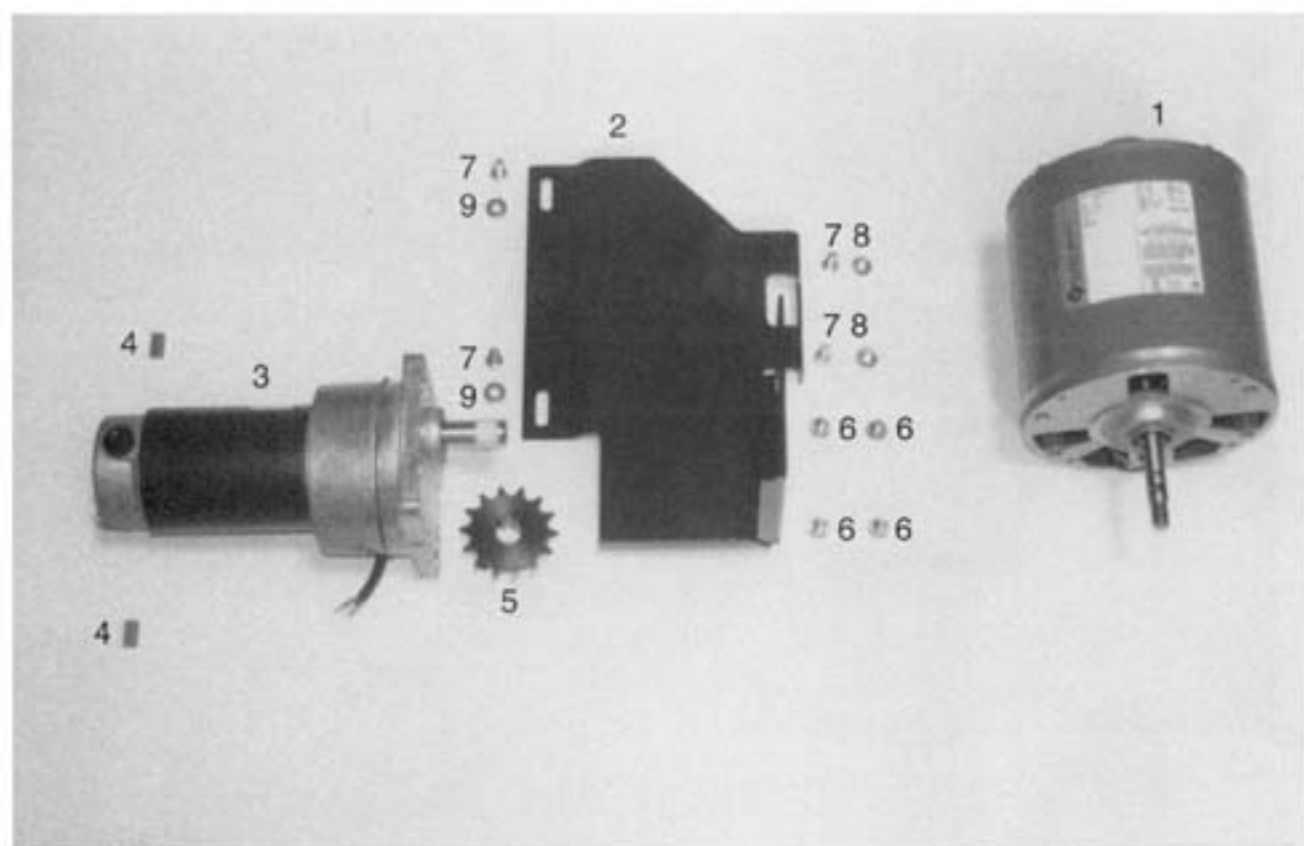

MOTORS AND AUTOMATIC MOTOR BASE

ITEM	DESCRIPTION	PART NUMBER	AUTO	MANUAL
1	KNIFE MOTOR 1/2 HP 115V-60HZ-1PH	834-8F	X	X
	KNIFE MOTOR 1/2 HP 220V-60HZ-1PH	834-11F	X	X
	KNIFE MOTOR 1/2 HP 220V-50HZ-1PH	834-10F	X	X
	KNIFE MOTOR-CANADA 1/2HP	834-9F	X	X
2	MOTOR BASE	984	X	
3	DC GEAR MOTOR (VW)	982-1	X	
4	DC MOTOR BRUSHES (VW) (2 REQ'D)	982-1B	X	
5	MOTOR SPROCKET (14T)	982-2	X	
6	SCREW (4 REQ'D)	762-6	X	
7	SCREW (4 REQ'D)	627-C	X	
8	NUT (2 REQ'D)	851-3FN	X	
9	WASHER (2 REQ'D)	888-2	X	
NOT SHOWN	WOODRUFF KEY	982-1K	X	

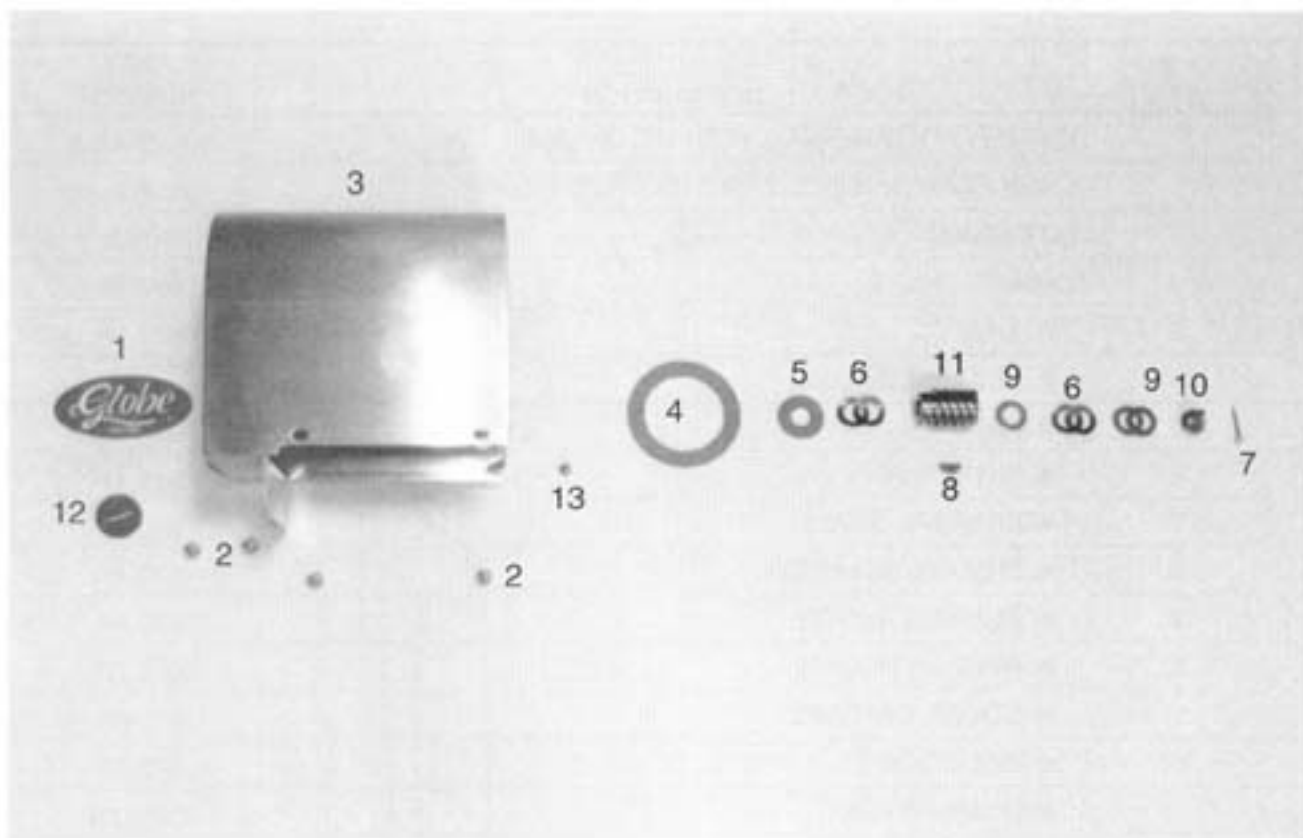

KNIFE MOTOR HARDWARE

ALL MODELS

ITEM	DESCRIPTION	PART NUMBER
1	GLOBE LOGO DECAL	871-2
2	MOTOR SHELL SCREW (4 REQ'D)	900-1
3	MOTOR SHELL 1/2 HP SS	975
	MOTOR SHELL 1/2 HP SS CANADA	975-C
4	CORK MOTOR GASKET	395
	MOTOR GEAR HARDWARE KIT	965
5	● MOTOR GEAR FLAT WASHER	375
6	● MOTOR GEAR BOWED WASHER (4 REQ'D)	810
7	● MOTOR SHAFT COTTER PIN	390
8	● MOTOR SHAFT KEY	375-A
9	● MOTOR GEAR FLAT WASHER (3 REQ'D)	809
10	● MOTOR SHAFT NUT	808
11	MOTOR GEAR	373
12	RESET BUTTON COVER - CANADA	796-D
13	MOTOR SHELL SCREW	975-1

KNIFE PLATE

ALL MODELS

ITEM	DESCRIPTION	PART NUMBER
	KNIFE PLATE ASSEMBLY WITH NYLON GEAR	972-P-AS-2
	KNIFE PLATE ASSEMBLY WITH BRONZE GEAR	972-P-AS-1
1	NUT, SHAFT	747-8
2	GASKET, SHAFT	972-9P
3	● SHAFT	972-2P
4	● RING, RETAINING	747-16
5	● KEY	747-18
6	● KNIFE PLATE	972-1P
7	● BEARING, SMALL	972-8P
8	● SPACER, BEARING	972-4P
9	● BEARING, LARGE	972-5P
10	● RING, RETAINING	972-7P
11	● COVER, BEARING	972-6P
12	● NUT, LOCK	972-3P
13	● GEAR, NYLON	747-17N
	● GEAR, BRONZE	747-17B
14	● KNIFE PLATE "O" RING	972-10P

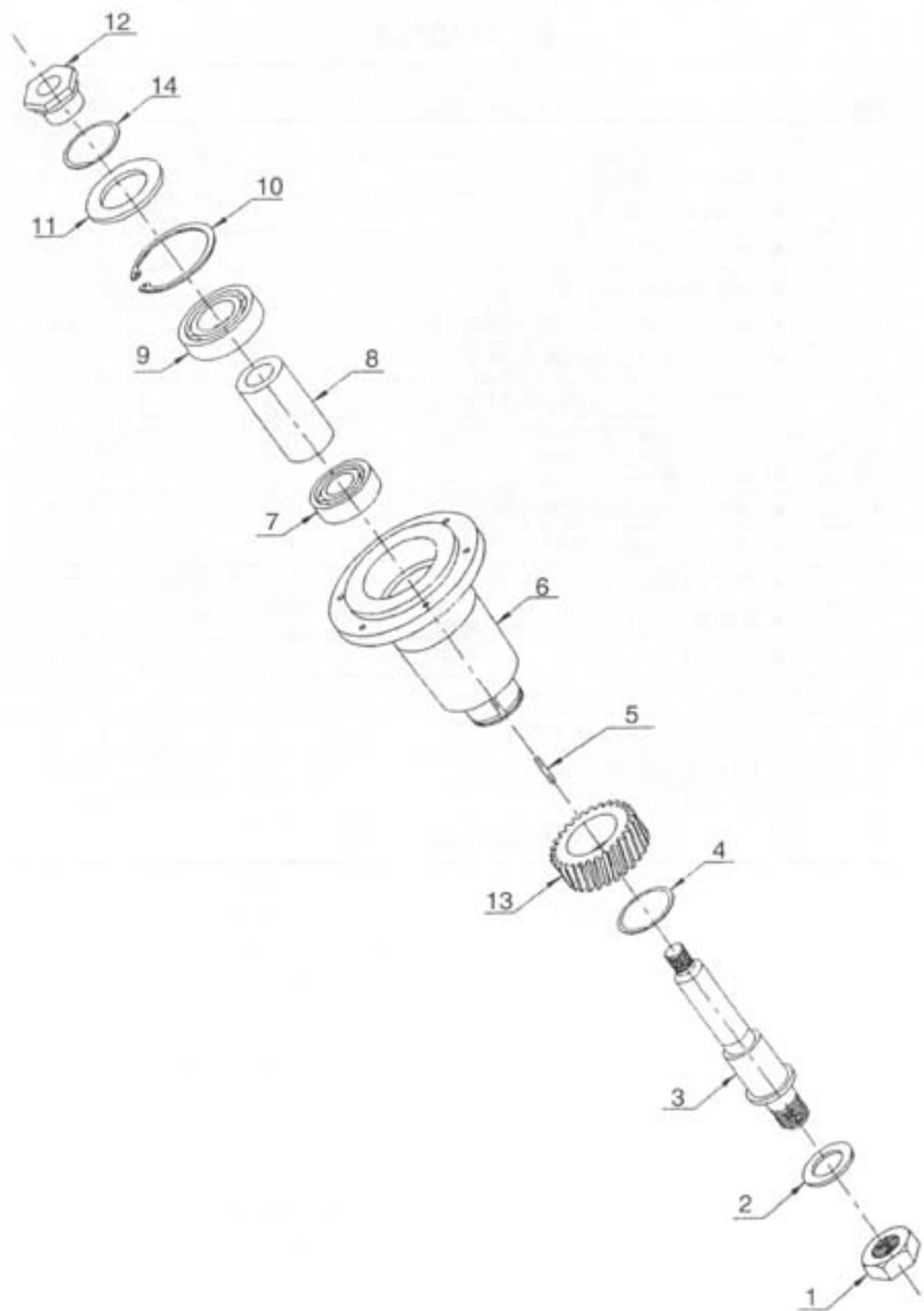

KNIFE COVER AND RIM GUARD

ALL MODELS

ITEM	DESCRIPTION	PART NUMBER
	KNIFE COVER ASSEMBLY	972-C-AS
1	● KNIFE COVER	955-1
2	● COVER KNOB	943-2
3	● KNIFE COVER HUB	972-1C
4	● HUB NUT (4 REQ'D)	955-3
5	● COVER KNOB SCREW (STANDARD)	726-6
	● SCRAPER SCREW (OPTIONAL)	966-5
6	● COVER KNOB / SCRAPER NUT	943-2
7	KNIFE SCRAPER - (OPTIONAL)	966-4
	RIM GUARD ASSEMBLY	942-AS
8	● UPPER RIM GUARD KNOB	821-4
9	● UPPER RIM GUARD	942-2
10	● KNIFE COVER STOP PIN (2 REQ'D)	822-5
11	● RIM GUARD HINGE SCREW	942-3
14	● LOWER RIM GUARD	942-1
12	RIM GUARD SCREW - UPPER	944-1A
13	RIM GUARD SCREW - LOWER	944-2A
15	UPPER RIM GUARD ARM	944-1
16	LOWER RIM GUARD ARM	944-2
17	GEAR HOUSING ARM SCREW (4 REQ'D)	944-3

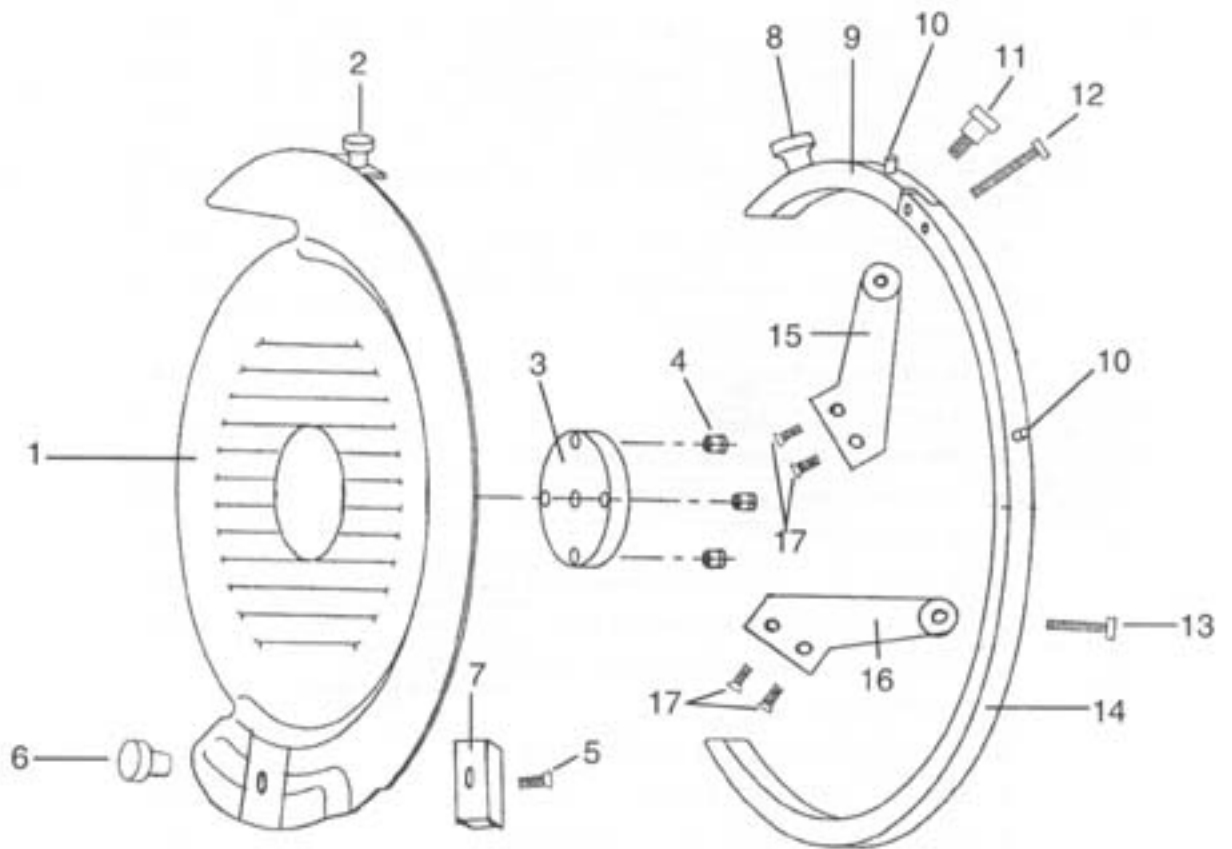

SHARPENER

ALL MODELS

ITEM	DESCRIPTION	PART NUMBER
	SHARPENER ASSEMBLY WITH COVER	450-H-AS
	SHARPENER ASSEMBLY WITHOUT COVER	10-A-1
1	● SHARPENER STONE NUT	228
2	● SHARPENER STONE WASHER (STEEL)	229
3	● SHARPENER STONE WASHER (FIBRE)	229-1
4	● SHARPENER TRUING STONE	213
5	● SHARPENER GRINDING STONE	214-A
	STONE SET (213 + 214-A)	214-5
6	● SHARPENER TRUING SHAFT ASSEMBLY	467-AS
7	● SHARPENER GRINDING SHAFT ASSEMBLY	463-AS
8	● SHARPENER HINGE BOLT NUT	286
9	● SHARPENER BRACKET	448
10	● SHARPENER HOUSING	450-H
11	● SHARPENER LOCK ROD ASSEMBLY	456-AS
12	● SHARPENER LOCK SPRING	458
13	● SHARPENER GEAR	455
14	● SHARPENER GEAR RETURNING SPRING	460
15	● SHARPENER GEAR SPACER RING	459
16	● SHARPENER GEAR SPACER RING SCREW	470-1
17	● SHARPENER HANDLE	495
18	● SHARPENER HANDLE SET SCREW	495-1
19	● SHARPENER LOCK KNOB	461
20	● SHARPENER LOCK ROD KNOB PIN	287-2
21	● SHARPENER BRACKET CLAMP SCREW WASHER	134
22	● SHARPENER HINGE BOLT WASHER	286-1
23	● SHARPENER BRACKET CLAMP SCREW	477
24	● SHARPENER HINGE BOLT	475
25	● SHARPENER SLEEVE PIN	300
26	● SHARPENER STOP BUSHING SCREW	470-1
27	● SHARPENER TRUING STONE STOP ASSEMBLY	471-AS
34	● BALL, STOP BUSHING	290
35	● SPRING, STOP BUSHING	238
36	● SHIM, SHARPENER BRACKET	448-1
37	● SCREW, SHAFT RETAINING	462-1
38	● PIN, STOP SHAFT	464
39	● SPRING	465
40	● SHAFT	463

SHARPENER (CONTINUED)

ALL MODELS

ITEM	DESCRIPTION	PART NUMBER
28	SHARPENER COVER	825
29	SHARPENER COVER HINGE SCREW	825-1
30	SHARPENER COVER HINGE SCREW WASHER	825-2
31	SHARPENER COVER HINGE NUT	825-3
32	SHARPENER COVER WARNING DECAL (ENGLISH)	967-2
	SHARPENER COVER WARNING DECAL (SPANISH)	967-2S
33	SHARPENER COVER TENSION WASHER	761-6

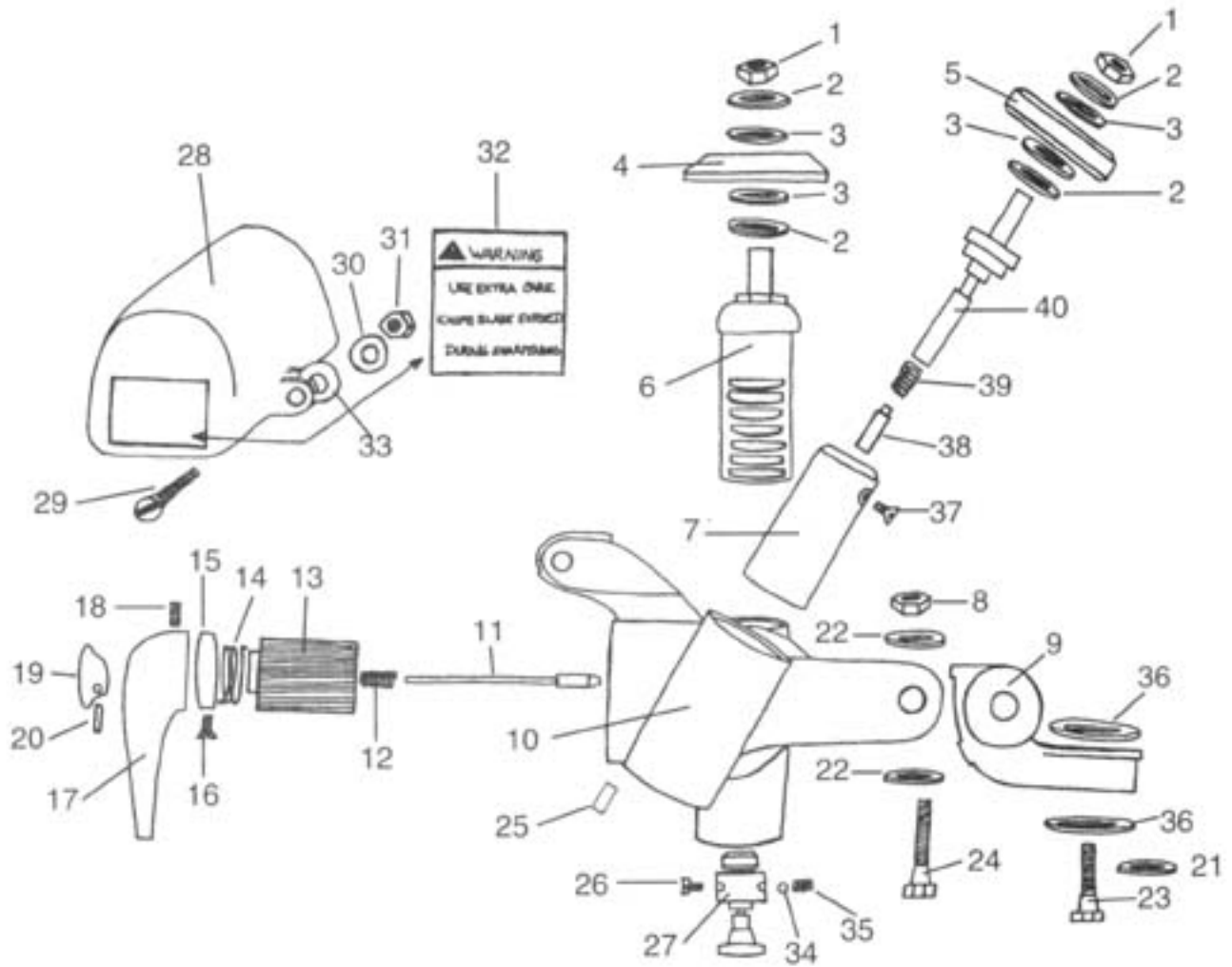

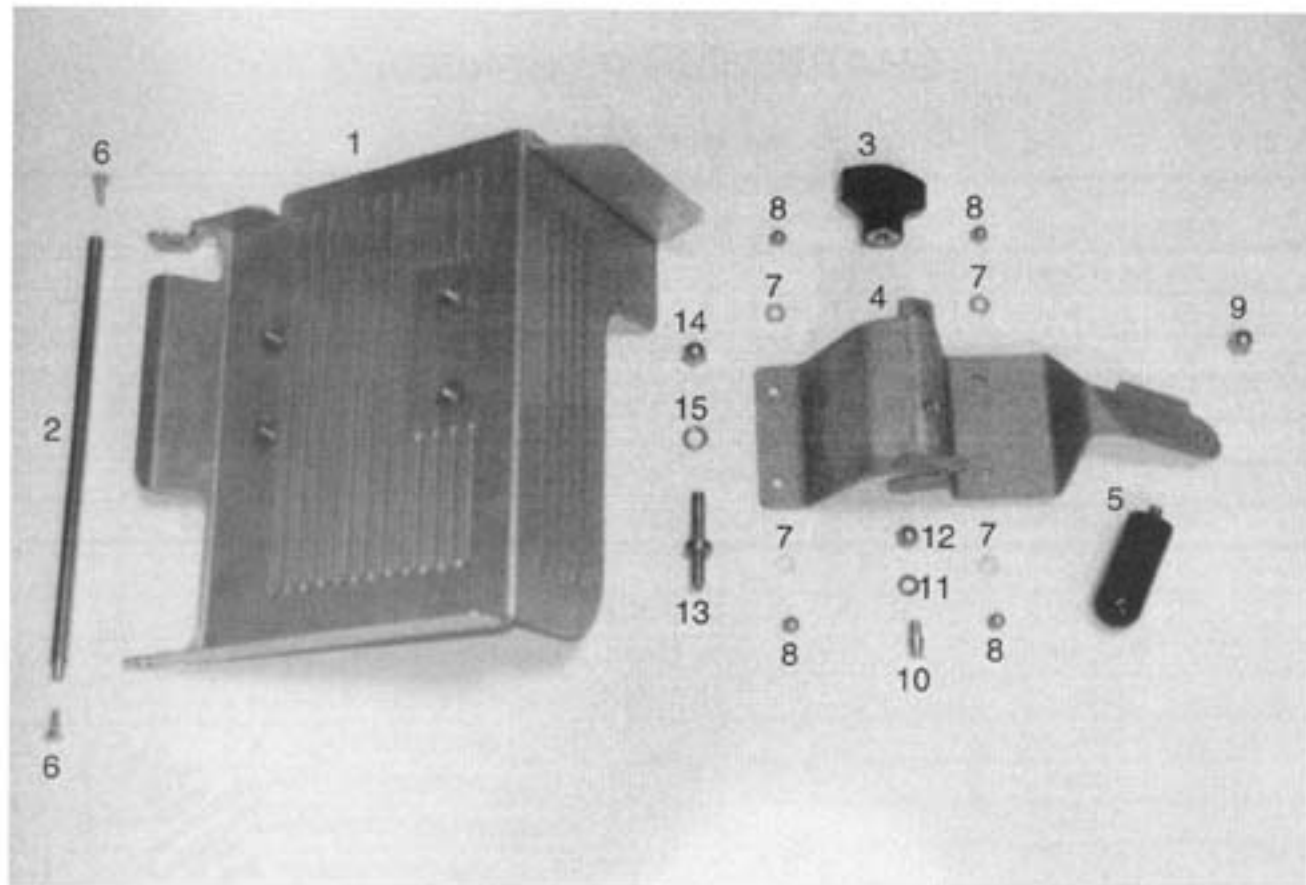

STAINLESS STEEL CHUTE AND SUPPORT

ITEM	DESCRIPTION	PART NUMBER	AUTO	MANUAL
	12" S.S. CHUTE ASSEMBLY W/O PRONGS	102-AS-12		X
	12" S.S. CHUTE ASSEMBLY - W/ PRONGS	102-AS-13	X	
1	● 12" CHUTE	962-S	X	X
2	● END WEIGHT ROD 11 1/8" LONG	962-18S	X	X
3	● SUPPORT NUT	798-B	X	X
4	● CHUTE SUPPORT	962-1E	X	X
5	● CHUTE HANDLE	482-B	X	X
6	● SCREW (2 REQ'D)	962-17	X	X
7	● WASHER (4 REQ'D)	825-2	X	X
8	● ACORN NUT (4 REQ'D)	962-6	X	X
9	● ACORN NUT	699-32	X	X
10	● LOCK BACK STUD	962-5	X	X
11	● LOCK WASHER	245-A	X	X
12	● ACORN NUT	962-7	X	X
13	● MAGNETIC CHUTE STUD ASSEMBLY	962-10-AS	X	X
14	● ACORN NUT	699-32	X	X
15	● LOCK WASHER	962-13	X	X

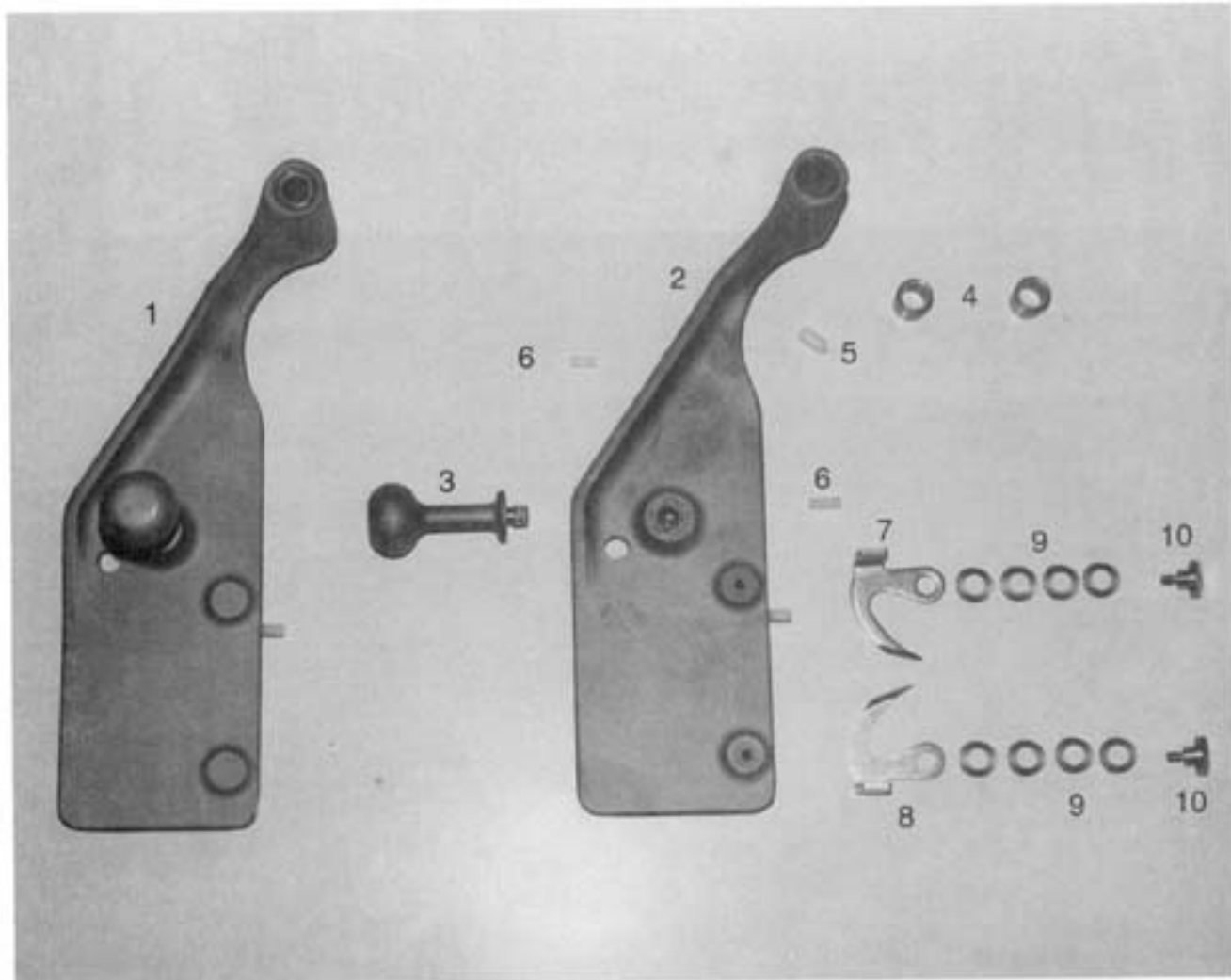

END WEIGHTS

ITEM	DESCRIPTION	PART NUMBER	AUTO	MANUAL
	S. S. END WEIGHT ASSEM. W/O PRONGS	741-SS-AS		X
	S. S. END WEIGHT ASSEM. W/ PRONGS	741-SS-APC	X	
1	● S. S. MANUAL END WEIGHT	741-SS1		X
2	● S. S. AUTOMATIC END WEIGHT	741-SS2	X	
3	● S. S. END WEIGHT HANDLE	741-SS3	X	X
4	● END WEIGHT BUSHING (2 REQ'D)	741-6	X	X
5	● END WEIGHT REST BUMPER	741-4A	X	X
6	● END WEIGHT SPACER BUMPER (2 REQ'D)	741-5B	X	X
7	● END WEIGHT PRONG (RIGHT)	741-PC2	X	
8	● END WEIGHT PRONG (LEFT)	741-PC3	X	
9	● PRONG SPRING WASHER (8 REQ'D)	741-PC5	X	
10	● PRONG SHOULDER SCREW (2 REQ'D)	741-SS4	X	

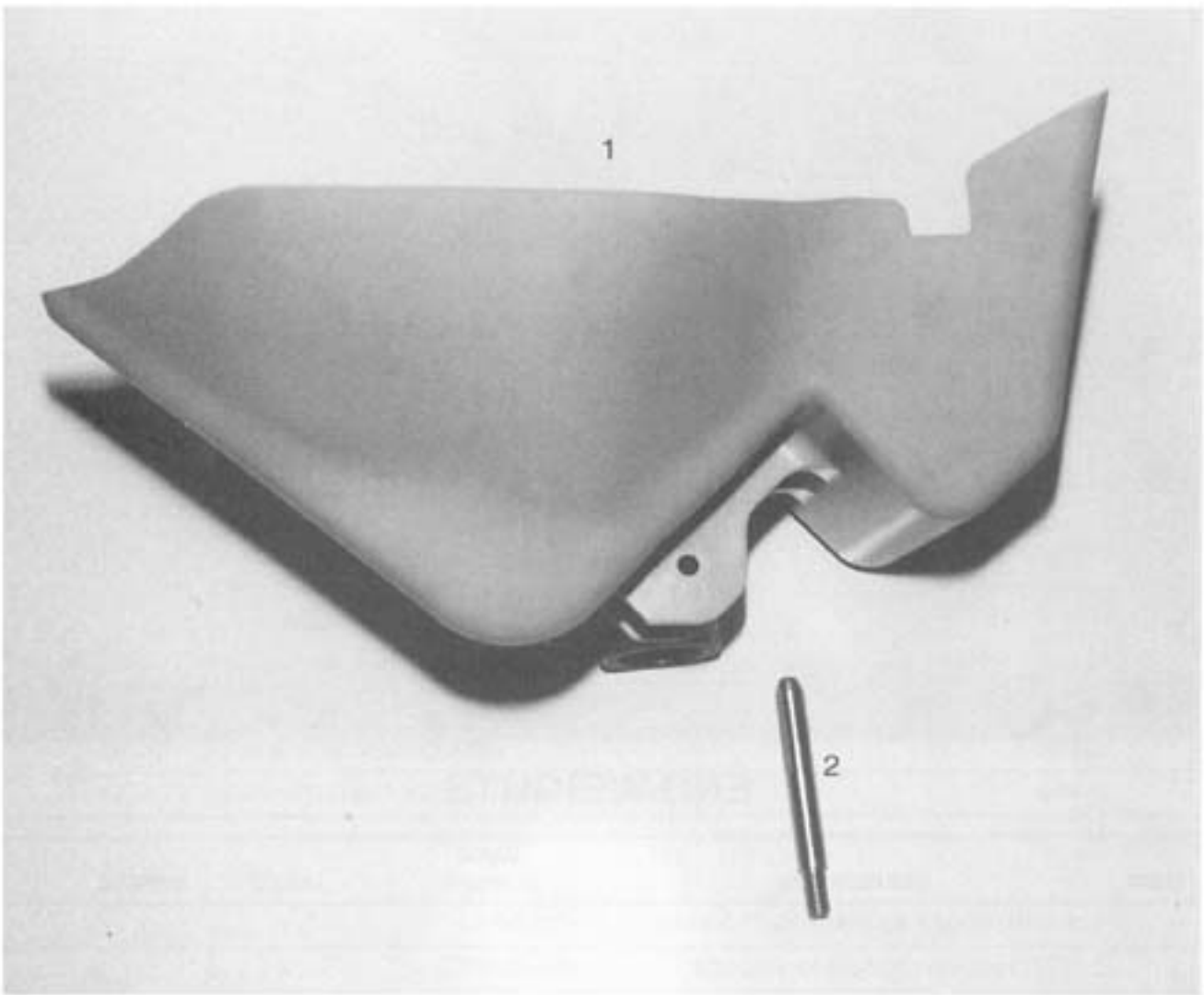

SLICE DEFLECTOR AND PIN

ALL MODELS

ITEM	DESCRIPTION	PART NUMBER
1	SLICE DEFLECTOR	968
2	SLICE DEFLECTOR PIN	968-1

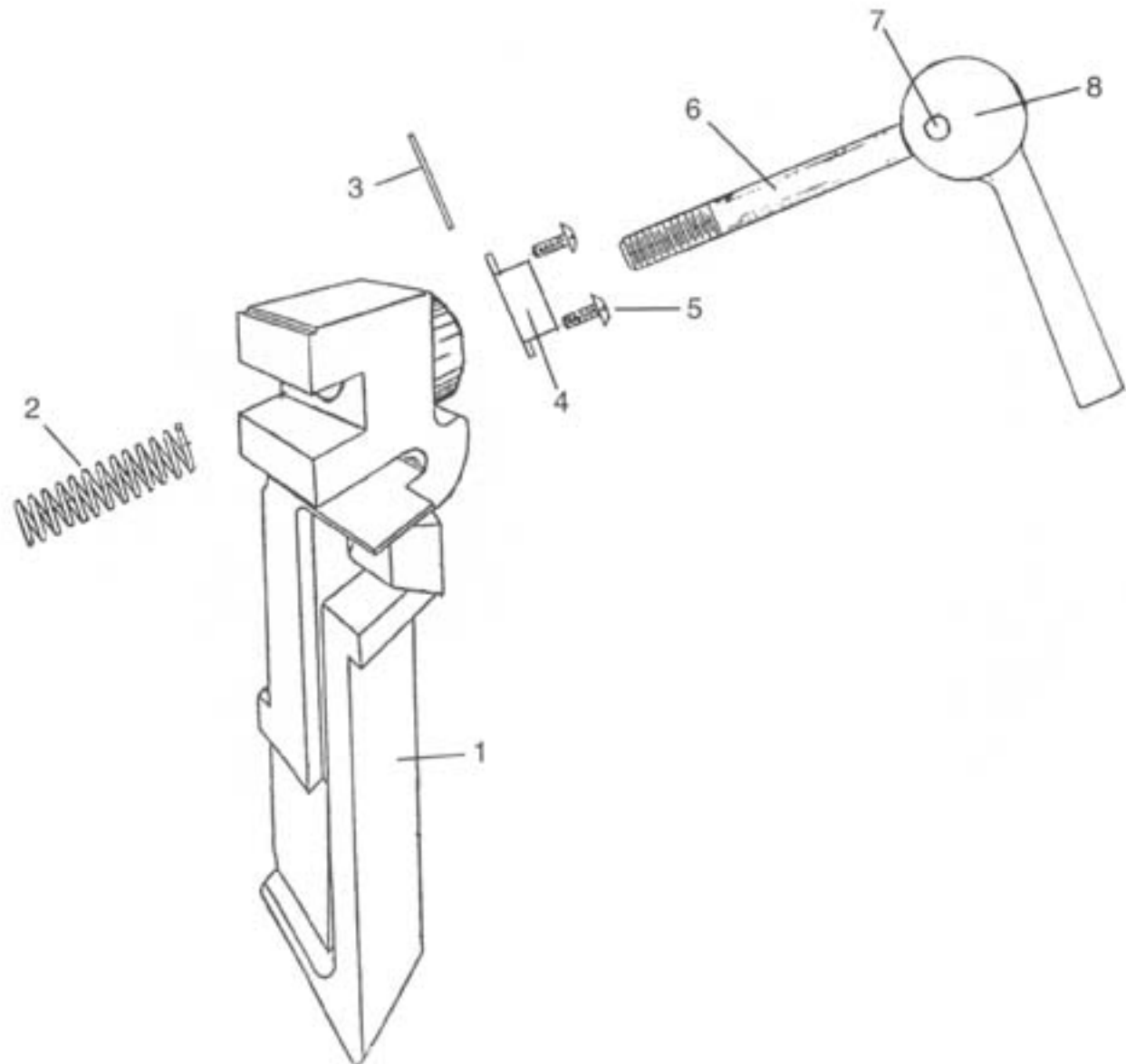

QUICK RELEASE AUTOMATIC CHAIN SLIDE

ALL AUTOMATIC MODELS

ITEM	DESCRIPTION	PART NUMBER
1	CHAIN SLIDE ASSEMBLY	974-AS
2	SPRING, CHAIN SLIDE	916-4
3	SHIM, CAM	916-5A,5B,5C
4	WASHER, CAM	916-5L
5	SCREW, CAM WASHER (2 REQ'D)	916-8
	CAM, CHAIN SLIDE ASSEMBLY	916-2-AS
6	● BOLT, CHAIN SLIDE EYE	916-1
7	● PIN, CAM	916-3
8	● CAM, CHAIN SLIDE	916-2

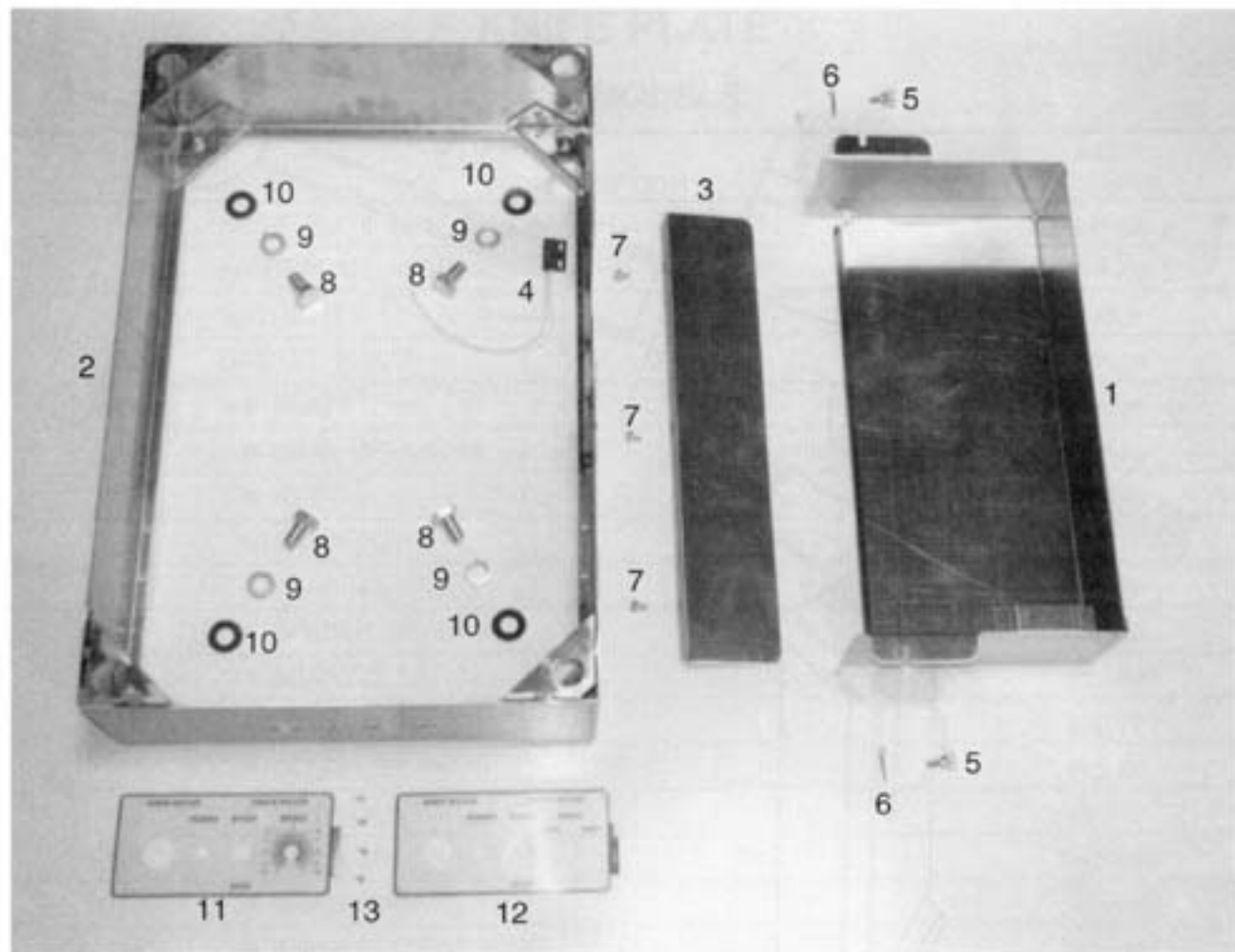

AUTOMATIC BASE APRON AND CHAIN GUARD

ITEM	DESCRIPTION	PART NUMBER
1	CHAIN COVER	985
2	BASE APRON	983
3	TOP CHAIN COVER	910-A
4	SWITCH, INTERLOCK	995-3AS
5	CHAIN GUARD THUMB SCREW (2 REQ'D)	917-2
6	COTTER PIN (2 REQ'D)	390
7	TOP GUARD MOUNTING SCREW (3 REQ'D)	889
8	APRON SCREW (4 REQ'D)	813
9	APRON LOCK WASHER (4 REQ'D)	815
10	APRON WASHER (4 REQ'D)	881-4
11	VARIABLE SPEED CONTROL OVERLAY	988
12	TWO SPEED CONTROL OVERLAY	989
13	DRIVE SCREW (4 REQ'D)	851-6P

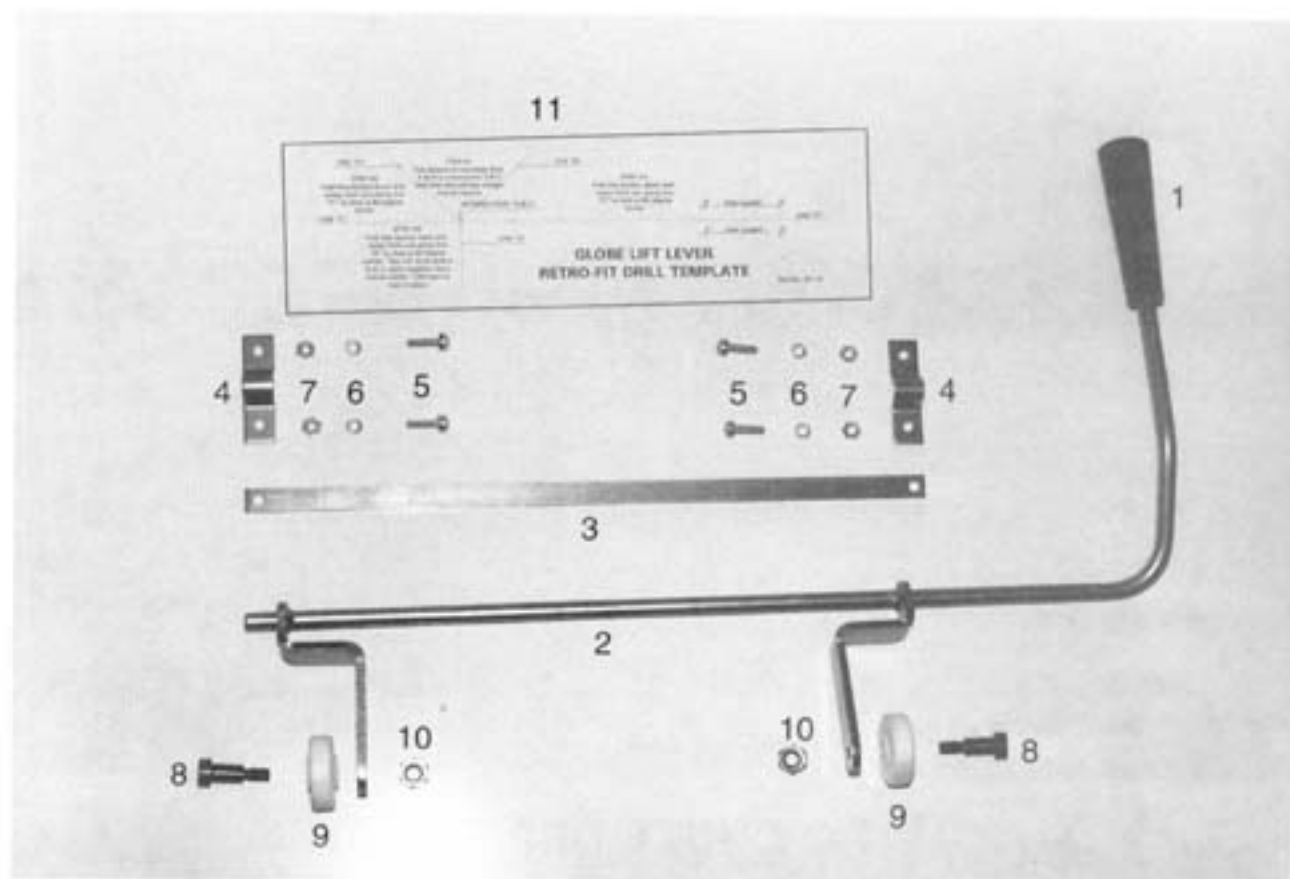

LIFT LEVER SYSTEM (ALL AUTOMATICS)

ITEM	DESCRIPTION	PART NUMBER
	LIFT LEVER KIT	951-ASW
1	● KNOB	951-8
2	● LIFT LEVER	951-3W
3	● STOP BAR	951-6
4	● PIVOT ROD CLIP (2 REQ'D)	951-2
5	● SCREW (4 REQ'D)	350
6	● LOCK WASHER (4 REQ'D)	925-26
7	● NUT (4 REQ'D)	760-5
8	● SHOULDER SCREW (2 REQ'D)	951-5
9	● ROLLER (2 REQ'D)	951-7
10	● NUT (2 REQ'D)	478-1
11	● DRILL TEMPLATE	951-9

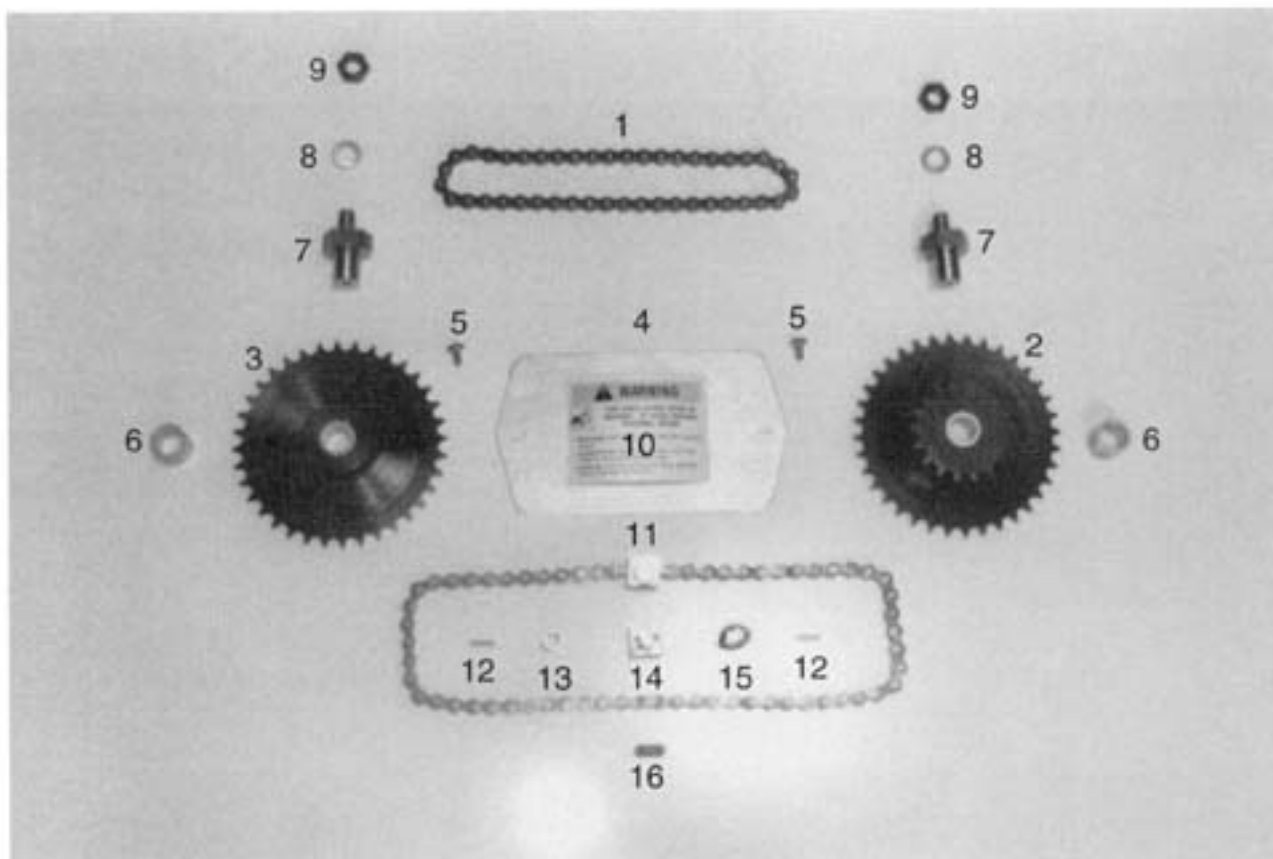

AUTOMATIC CHUTE DRIVE SYSTEM

ITEM	DESCRIPTION	PART NUMBER
1	44 LINK DRIVE CHAIN	970-10
2	18 & 36 TOOTH DRIVE SPROCKET	762-3
3	36 TOOTH BACK SPROCKET	762-2
4	SPROCKET BARRIER	762-5
5	BARRIER SCREW (2 REQ'D)	762-6
6	SPROCKET BUSHING (2 REQ'D)	762-4
7	SPROCKET STUD (2 REQ'D)	764-12
8	LOCK WASHER (2 REQ'D)	815
9	NUT (2 REQ'D)	646
10	BARRIER WARNING LABEL	967-3
	BARRIER WARNING LABEL - SPANISH	967-3S
11	64 LINK SLIDE DRIVE CHAIN ASSEMBLY	766-2B-AS
12	● CHAIN CONNECTOR PIN (2 REQ'D)	766-4
13	● CAM FOLLOWER	974-3
14	● CHAIN CONNECTOR	612
15	● CAM FOLLOWER RETAINING RING	612-2
16	● MASTER LINK	610

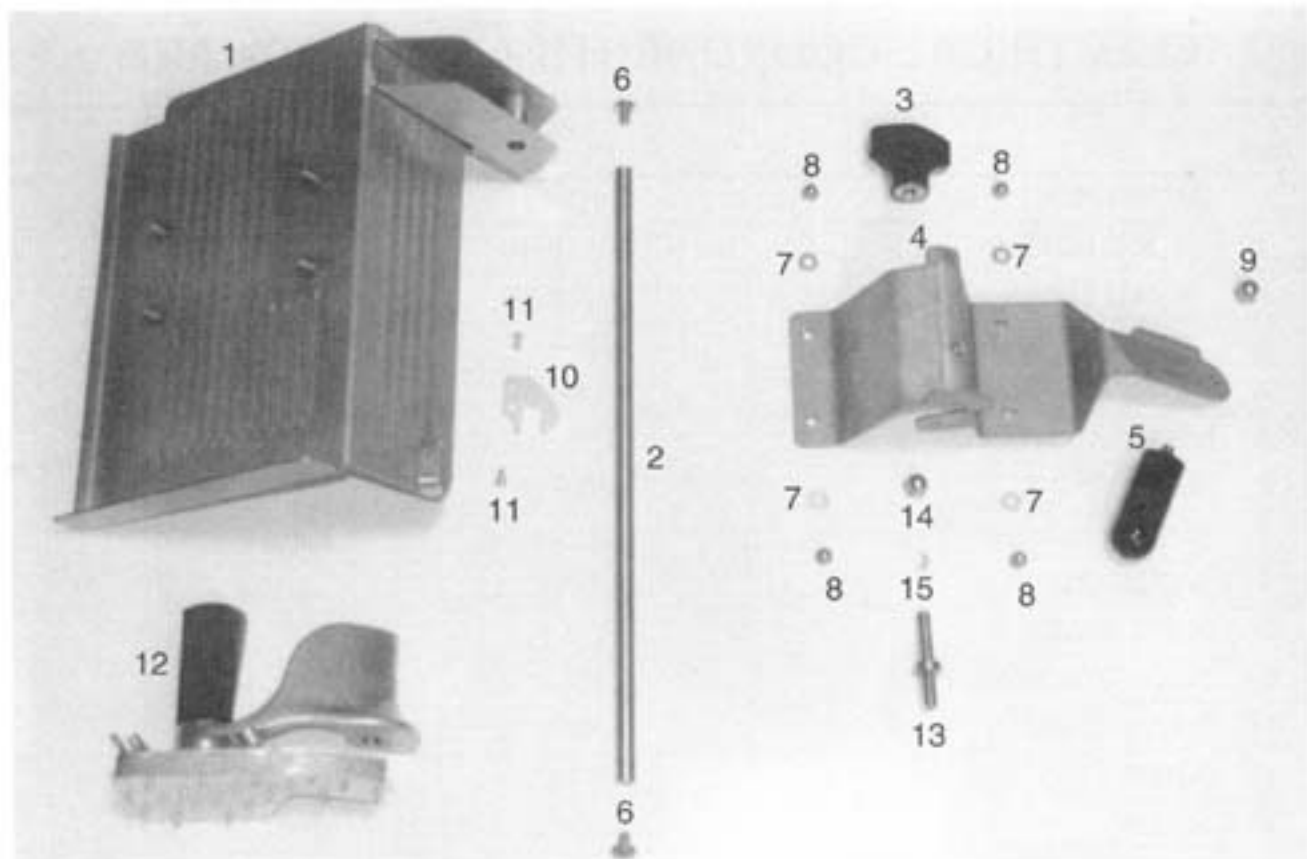

FRONT MOUNTED END WEIGHT CHUTE ASSEMBLY ALL MODELS

ITEM	DESCRIPTION	PART NUMBER
	FRONT MOUNTED END WEIGHT CHUTE ASSEMBLY	102-AS-15
1	● FRONT MOUNTED END WEIGHT CHUTE	981
2	● END WEIGHT ROD	981-1
3	● SUPPORT NUT	798-B
4	● CHUTE SUPPORT	962-1E
5	● CHUTE HANDLE	482-B
6	● SCREW (2 REQ'D)	981-2
7	● FLAT WASHER (4 REQ'D)	825-2
8	● ACORN NUT (4 REQ'D)	962-6
9	● ACORN NUT	699-32
10	● END WEIGHT REST	981-4
11	● SCREW (2REQ'D)	709-1
12	● END WEIGHT ASSEMBLY, FRONT MOUNTED	981-3AS
13	● MAGNETIC CHUTE STUD ASSEMBLY	962-10-AS
14	● ACORN NUT	699-32
15	● LOCK WASHER	962-13

ELECTRICAL COMPONENTS AND HARDWARE

ITEM	DESCRIPTION	PART NUMBER	AUTO	MANUAL
	MAIN SWITCH	952-10	X	
1	● N.O. CONTACT	952-10-NO	X	
2	● N.C. CONTACT	952-10-NC	X	
3	● OPERATOR PUSH BUTTON	952-10-OP	X	
4	● SWITCH BASE	952-10-BS	X	
5	MAIN SWITCH BOOT	952-10-B	X	
6	NUT	851-3FN	X	X
7	SCREW	851-1	X	X
8	SWITCH BOX	952-4		X
9	NUT (4 REQ'D)	765-5	X	
10	ELECTRICAL WIRING BOX	986-F	X	
11	SCREW (2 REQ'D)	867-1	X	X
12	COVER	850-DC5E	X	X
13	SCREW	854-6		X
14	SCREW (2 REQ'D)	889		X
15	COVER	952-5		X
16	SCREW (3 REQ'D)	854-6	X	X
17	BOX COVER	986-1F	X	X
18	TERMINAL STRIP	995-24	X	X
19	RELAY BRACKET COVER	952-1	X	X
20	SCREW (2 REQ'D)	852-1	X	X
21	PLUG	850-3	X	X
22	STRAIN RELIEF	877	X	X
23	SWITCH BOX	995-21B	X	X
24	SQUARE ROD	995-21P1	X	X
25	"C" CLIP	940-10	X	X
26	ROUND ROD	995-21P2	X	X
27	BUSHING	995-22	X	X
28	SEAL	995-22S	X	X
29	RED KNOB	995-21K	X	X
30	FUSE AND CORD BRACKET	992-3	X	X
31	SPEED KNOB	995-10	X	
32	N.O. SWITCH	854-1	X	X

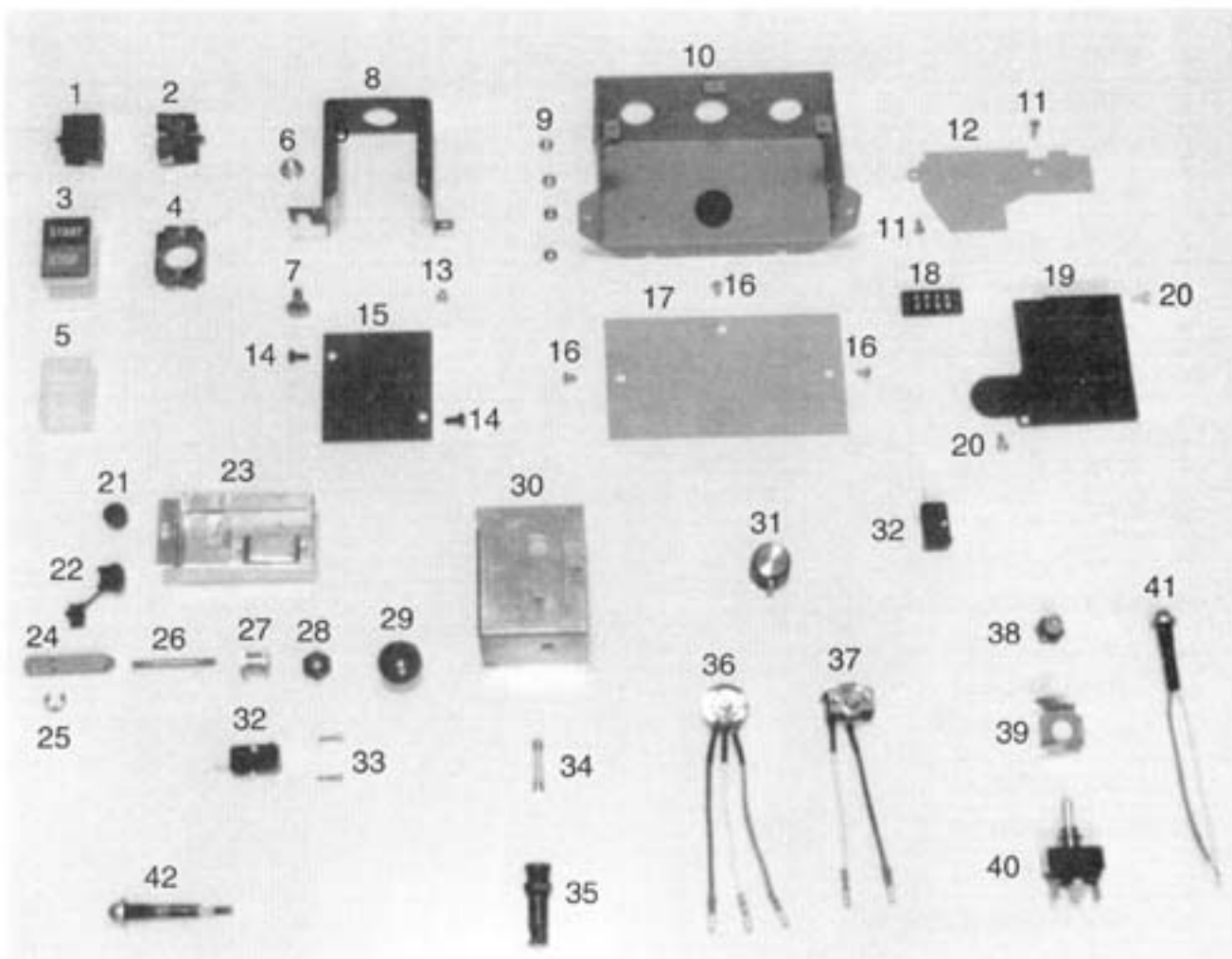

ELECTRICAL COMPONENTS AND HARDWARE

ITEM	DESCRIPTION	PART NUMBER	AUTO	MANUAL
33	SCREW (2 REQ'D)	995-30	X	X
34	10A-220VAC-SB	995-9F	X	X
35	FUSE HOLDER	995-9	X	X
36	POTENTIOMETER 50K	997-5-AS	X	
37	2 SPEED SWITCH (4750)	995-5-AS	X	
38	SWITCH BOOT, TOGGLE	952-13	X	X
39	SWITCH GUARD	785-1SG	X	X
40	3 POSITION SWITCH	952-8	X	X
41	POWER L.E.D. 24VDC	995-4		X
42	POWER L.E.D. 24VDC	995-4A	X	

WIRING HARNESS AND COMPONENTS

ITEM	DESCRIPTION	PART NUMBER	AUTO	MANUAL
1	WIRE	966-5	X	
2	POWER CORD	995-6	X	X
3	WIRE	996-2	X	
4	STRAIN RELIEF	877	X	X
5	STRAIN RELIEF	952-12	X	X
6	WIRE	996-11	X	X
7	SMALL WIRE CONNECT	869-A1	X	X
8	LARGE WIRE CONNECT	952-15	X	X
9	WIRE TIE	995-27	X	X
10	GROUND WIRE	996-8	X	X
11	WIRE	956-4	X	X
12	WIRE	956-3	X	X
13	WIRE	956-2	X	X
14	WIRE	956-1	X	X
15	RETRACTABLE CORD	995-8	X	X
16	WIRE HARNESS	995-21C	X	X
17	WIRE HARNESS	995-M2		X
18	WIRE HARNESS	995-M3		X
19	WIRE HARNESS	995-V2-3	X	
20	WIRE HARNESS	995-V2-1	X	
21	WIRE HARNESS (4750)	995-2S-2	X	
22	WIRE HARNESS (4875V)	995-VS-2	X	
NOT SHOWN	INTERLOCK WIRE ASSEMBLY	995-16	X	
NOT SHOWN	INTERLOCK WIRE ASSEMBLY	995-16M		X

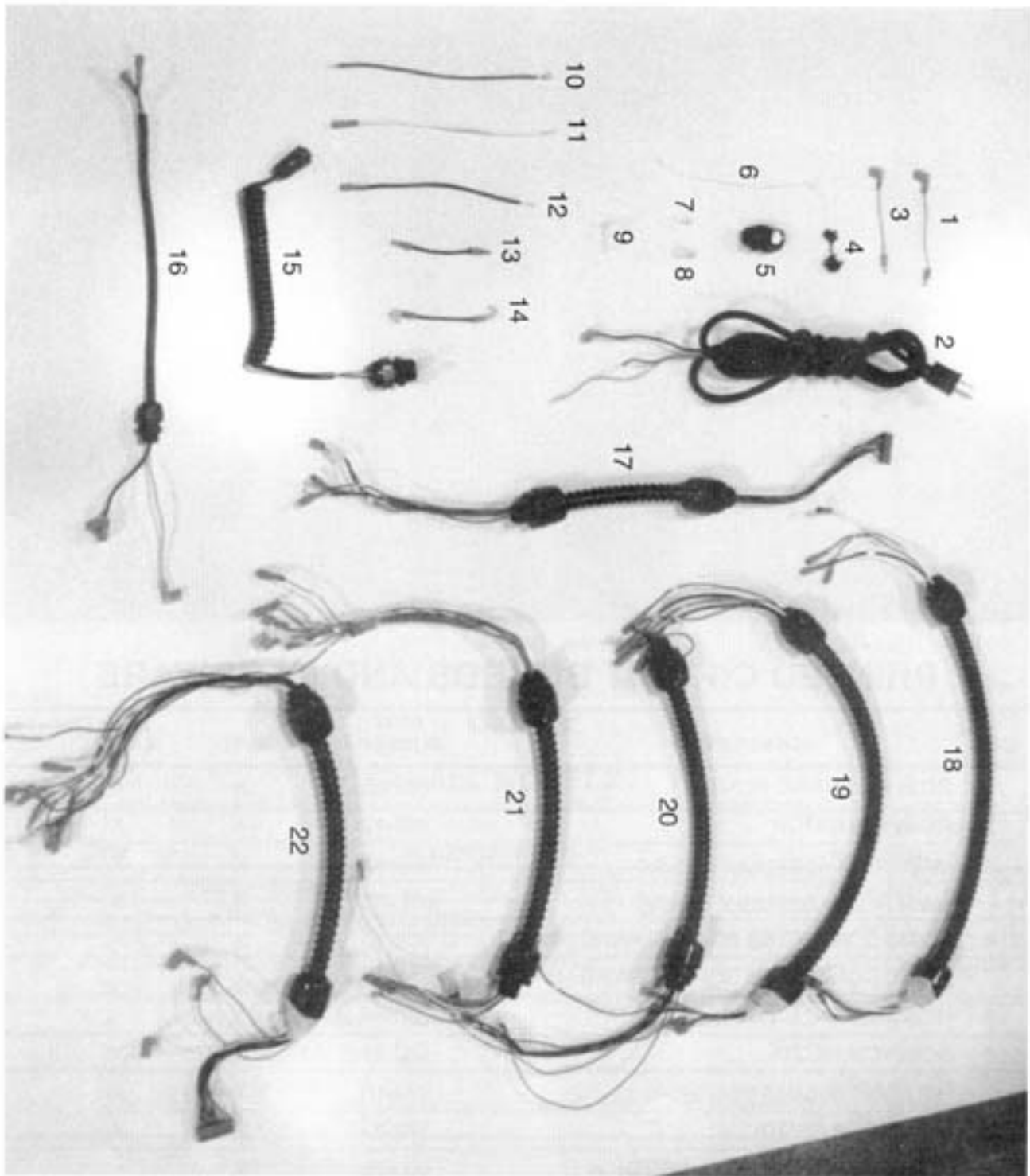

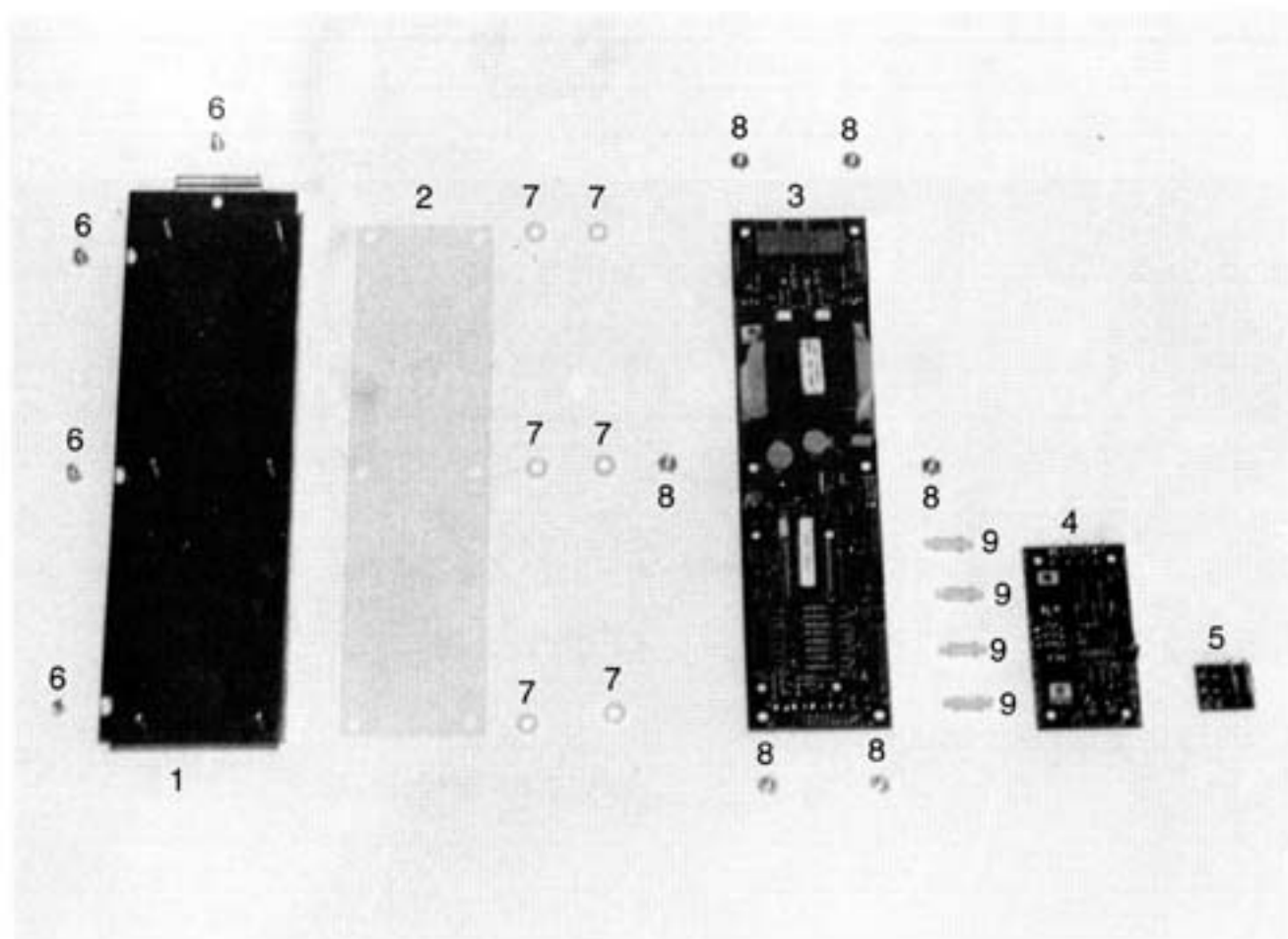

PRINTED CIRCUIT BOARDS AND HARDWARE

ITEM	DESCRIPTION	PART NUMBER	AUTO	MANUAL
1	P.C.B. MOUNTING PLATE	992-2E	X	X
2	P.C.B. INSULATOR	995-13	X	X
3	MAIN P.C.B. ASSEMBLY 110VAC	992-AS	X	X
	MAIN P.C.B. ASSEMBLY 220VAC	992-220	X	X
4	AC-DC CONVERTER BOARD 110VAC (4875V)	982-1C	X	
	AC-DC CONVERTER BOARD 220VAC (4875V)	982-220	X	
5	RESISTOR P.C.B. (4750)	998-AS	X	
6	SCREW (4 REQ'D)	952-21	X	X
7	NYLON SPACER (6 REQ'D)	970-1N	X	X
8	HEX NUT (6 REQ'D)	952-23	X	X
9	P.C.B. SUPPORT POST (4 REQ'D)	995-15	X	
NOT SHOWN	AC-DC ASSEMBLY (4750) 110VAC	995-12AS	X	
NOT SHOWN	AC-DC ASSEMBLY (4750) 220VAC	995-25AS	X	

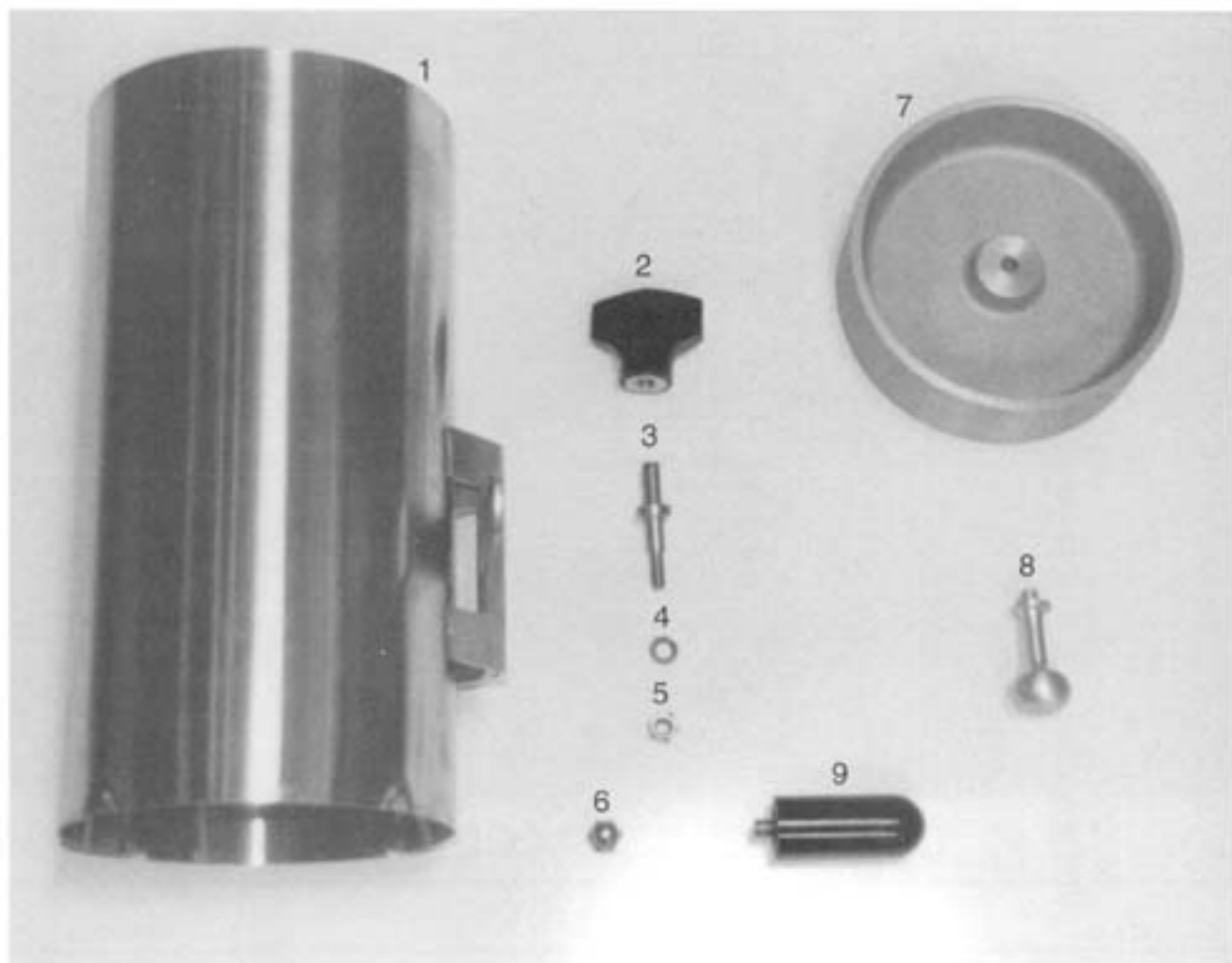

VEGETABLE HOPPER ACCESSORY

ITEM	DESCRIPTION	PART NUMBER
	VEGETABLE HOPPER ASSEMBLY	699-EAS
1	● HOPPER BODY WITH SUPPORT	699-1EW
2	● HOPPER NUT	798-B
3	● MAGNETIC CHUTE STUD ASSEMBLY	962-10-AS
4	● LOCK WASHER	962-13
5	● ACORN NUT	699-32
6	● ACORN NUT	699-32
	HOPPER END WEIGHT ASSEMBLY	699-16
7	● HOPPER END WEIGHT	699-17
8	● END WEIGHT HANDLE	699-18
9	HOPPER HANDLE	482-B

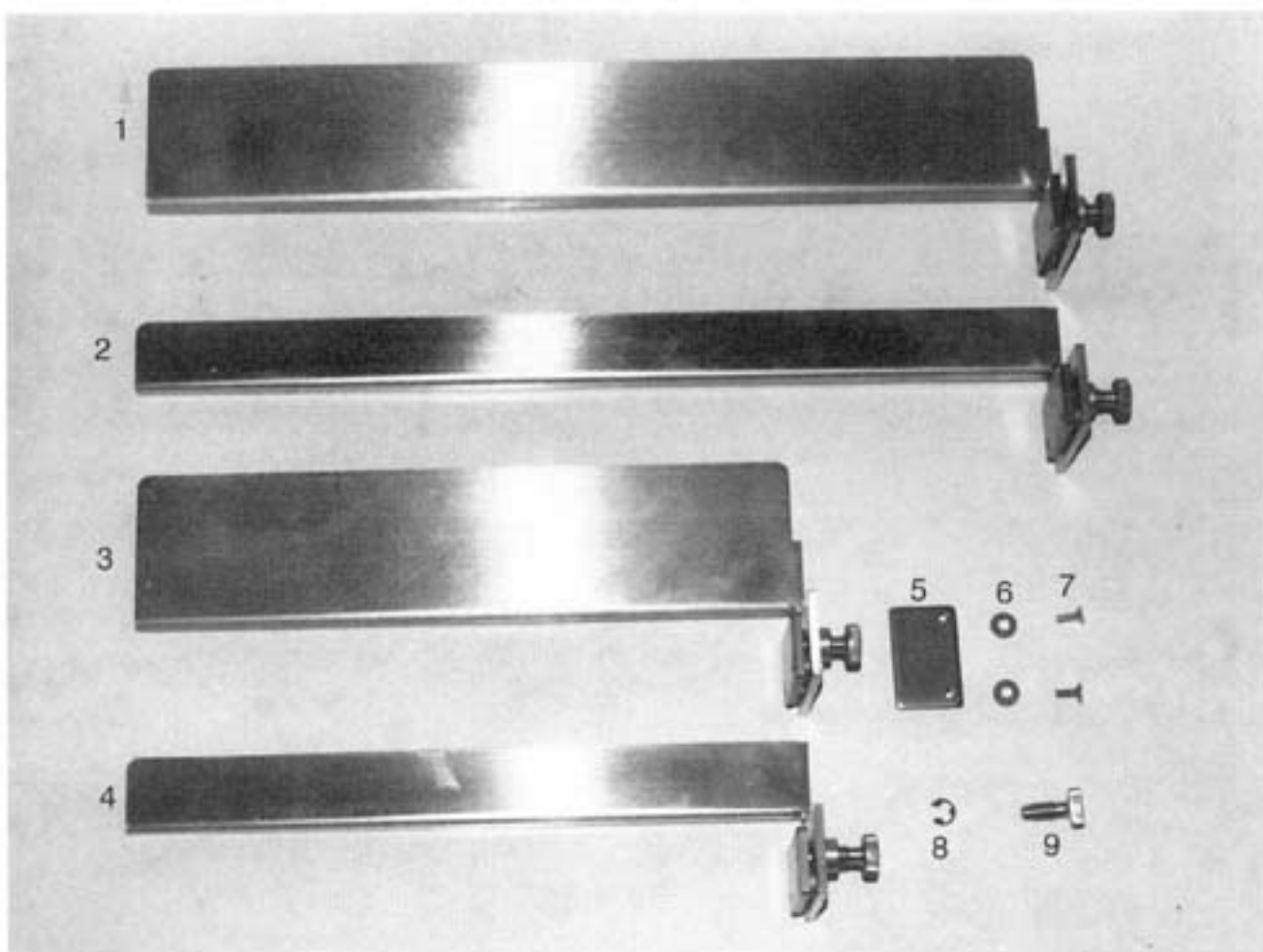

CHUTE FENCES ACCESSORY

ITEM	DESCRIPTION	PART NUMBER
	FENCE ASSEMBLY 17" X 3"	940-FLH
	FENCE ASSEMBLY 17" X 1 3/8"	940-FLL
	FENCE ASSEMBLY 12" X 3"	940-FSH
	FENCE ASSEMBLY 12" X 1 3/8"	940-FSL
1	● FENCE 17" X 3"	940-9LT
2	● FENCE 17" X 1 3/8"	940-9LL
3	● FENCE 12" X 3"	940-9ST
4	● FENCE 12" X 1 3/8"	940-9SL
5	● FENCE CLAMP	940-5
6	● CLAMP SPACER (2 REQ'D)	940-7
7	● CLAMP MOUNTING SCREW (2 REQ'D)	699-25
8	● RETAINING RING	940-10
9	● CLAMP THUMB SCREW	940-6

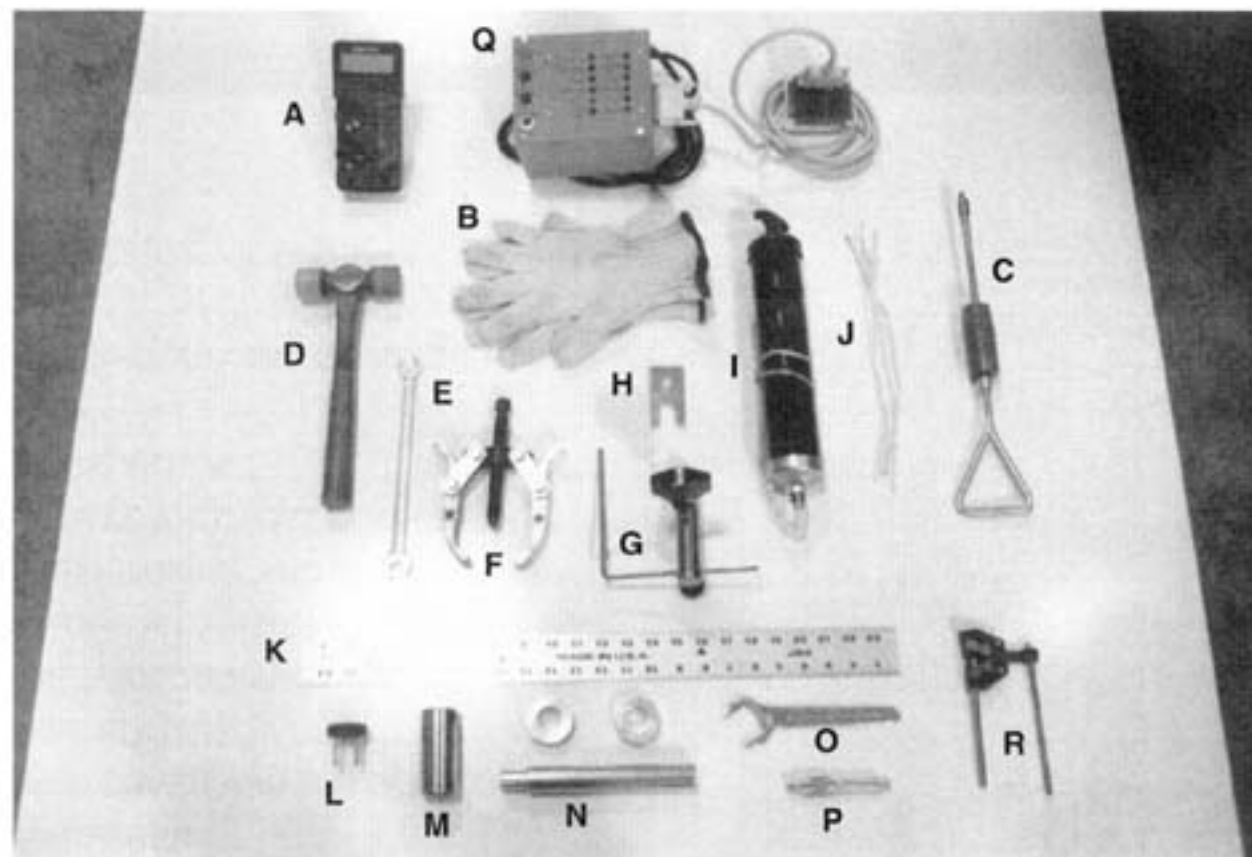

TOOL LIST

ITEM	DESCRIPTION	PART NUMBER
A	DIGITAL TEST METER	PL.
B	CUT RESISTANT GLOVES	PL.
C	SLIDE ROD HAMMER	PL.
D	RUBBER / NYLON HAMMER	PL.
E	1/2" - 9/16" THIN TAPPET WRENCH	PL.
F	GEAR PULLER	PL.
G	KNIFE ALIGNMENT TOOL	963-AT
H	KNIFE PLATE ASSEMBLY WRENCH	747-14ST
I	FLUID SIPHON	PL.
J	CLEANING WIRES	PL.
K	24" STRAIGHT EDGE	PL.
L	SHARPENER SPRING TENSION TOOL	450-ST
M	1 1/16" DEEP WELL SOCKET	PL.
N	BEARING TOOL	747-BT
O	1 1/4" PUMP WRENCH	PL.
P	FUSE PULLER	PL.
Q	CABLE TESTER (4000 SERIES)	T-995-AS
R	CHAIN BREAKER	PL.

*PL. = PURCHASED LOCALLY