

PARTS LIST



SLICING MACHINES

**MODELS: 500L, 725L, 775L, 825L, 875L, 850L,
500LR, 725LR, 775LR, 825LR, 875LR & 850LR**

IMPORTANT!
TO EXPEDITE SHIPMENT OF PARTS, ALWAYS SPECIFY MODEL, REV,
PART NUMBER, AND SERIAL NUMBER OF SLICER.

GLOBE FOOD EQUIPMENT COMPANY

2268 N. Moraine Drive
Dayton, Ohio 45439

Parts Department

Toll Free 1-800-745-6238 • Fax (937) 290-0585

E-Mail: globeinfo@globeslicers.com

Website: www.globeslicers.com

TABLE OF CONTENTS

ASSEMBLIES AND ACCESSORIES	1
CHUTE PARTS	2
BASE PARTS	3
AUTOMATIC SLICER BASE PARTS	4
END WEIGHT PARTS WITHOUT PRONGS	5
AUTOMATIC END WEIGHT PARTS WITH PRONGS	6
AUTOMATIC CHUTE DRIVE	7
SLIDE PARTS	8
GEAR HOUSING PARTS	9
KNIFE GUARD PARTS	10
KNIFE AND KNIFE HUB ASSEMBLY	11
KNIFE MOTOR PARTS	13
AUTOMATIC SLICER LIFT LEVER	14
SHARPENER PARTS	15
ARM AND HINGE ASSEMBLIES FOR THE 500L & 500LR	17
LUBRICATING OIL	17
RECEIVING TRAY PARTS	18
TABLE ADJUSTMENT PARTS	19
SLICE DEFLECTOR PARTS	21
AUTOMATIC SLICER SPROCKET PARTS	22
775L DRIVE SYSTEM	23
775L VARIABLE SPEED CONTROL	24
CHUTE MOTOR (Single Speed Units)	25
QUICK RELEASE AUTOMATIC CHAIN SLIDE	26
ELECTRONIC VARIABLE SPEED CONTROL (Models 875LR & 850LR)	27
RING GUARD PARTS (All Models)	28
AUTOMATIC SLICER LIFT LEVER	29
SWITCH PARTS	29
NO VOLTAGE RELEASE - METAL PARTS	31
NO VOLTAGE RELEASE - ELECTRONIC PARTS	32

ASSEMBLIES & ACCESSORIES

ASSEMBLY DESCRIPTION	MODELS	PART NUMBER	DESCRIPTION
Sharpener Assembly	All	10-A-1	All Sharpener parts exclusive of Cover, Cover Screw and Nut---825, 825-1, 825-3
SST Chute 12" (Manual)	All	102-AS-5	Chute, Support, Endweight Complete w/o Prongs
SST Chute 12" (Automatic)	All	102-AS-7	Chute, Support, Endweight Complete with Prongs
Aluminum Chute 12" (Manual)	All	102-AS-1	Chute, Support, Endweight Complete w/o Prongs
Aluminum Chute 12" (Automatic)	All	102-AS-2	Chute, Support, Endweight Complete with Prongs
SST Chute 17" (Automatic)	All	102-AS-6	Chute, Support, Endweight Complete with Prongs
Top Knife Cover	All L Units	127-A-1	Cover, Center Support, Scraper and Knobs
Top Knife Cover	All LR Units	955-AS	Cover, Center Support and Knobs
Knife Plate Assy. (Fiber Gear)	All	932-AS	Entire Assy. with Coupling and Ring
Knife Plate Assy. (Bronze Gear)	All	932-AS-1	Entire Assy. with Coupling and Ring

ACCESSORIES

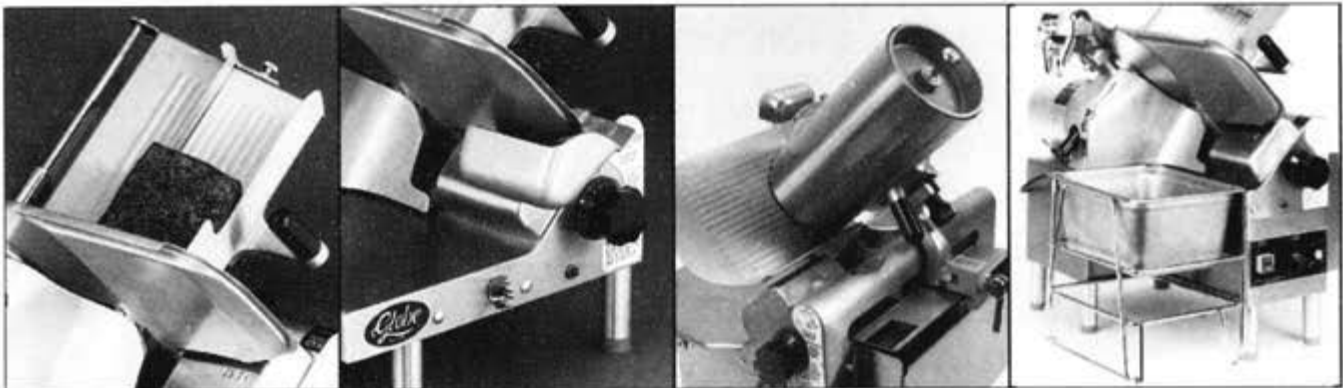

FENCE

JUICE BOX

VEGETABLE HOPPER

RECEIVING PAN

DESCRIPTION	PART NUMBER
VEGETABLE HOPPER (CYLINDER CHUTE)	699-AS
JUICE BOX	676-AS
FENCE SHORT-HIGH 12" x 3" HIGH	940-FSH
FENCE SHORT-LOW 12" x 1 3/8" HIGH	940-FSL
FENCE LONG-HIGH 17" x 3" HIGH	940-FLH
FENCE LONG-LOW 17" x 1 3/8" HIGH	940-FLL
RECEIVING PAN, LID, STAND	958-AS

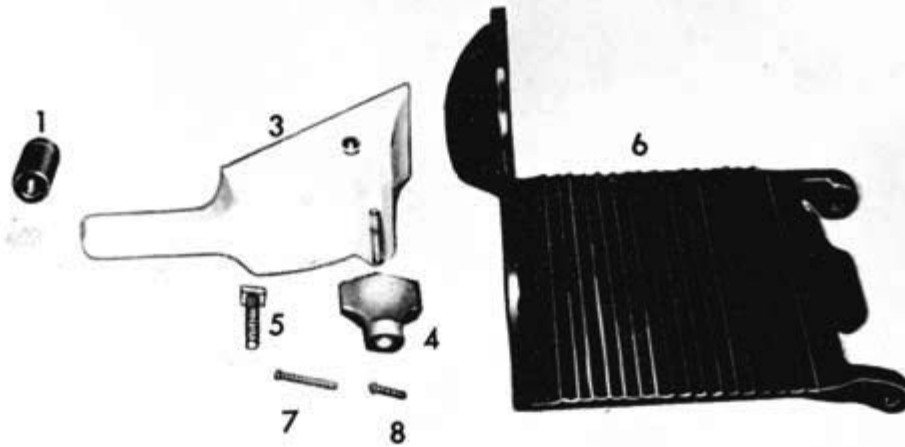

CHUTE PARTS

ITEM	DESCRIPTION	MODEL 500L	ALL AUTOMATICS
1	Chute Handle Black	482-B	482-B
3	Chute Support With Handle (also includes 1 & 5)	743-AS	743-AS
4	Chute Support Nut	798-B	798-B
5	Chute Support Tee Bolt	481-1	481-1
6	Chute (Alum) (Short 12" High)	740	740
6	Chute (SST) (Short 12" High)	940-S	-
6	Chute (SST) (Long 17" High)	-	940-L
7	Chute Support Screw (Short) (2 required)	439-1	439-1
8	Chute Support Screw (Long) (2 required)	439-2	439-2

Note: For Complete Assemblies, See Page # 1

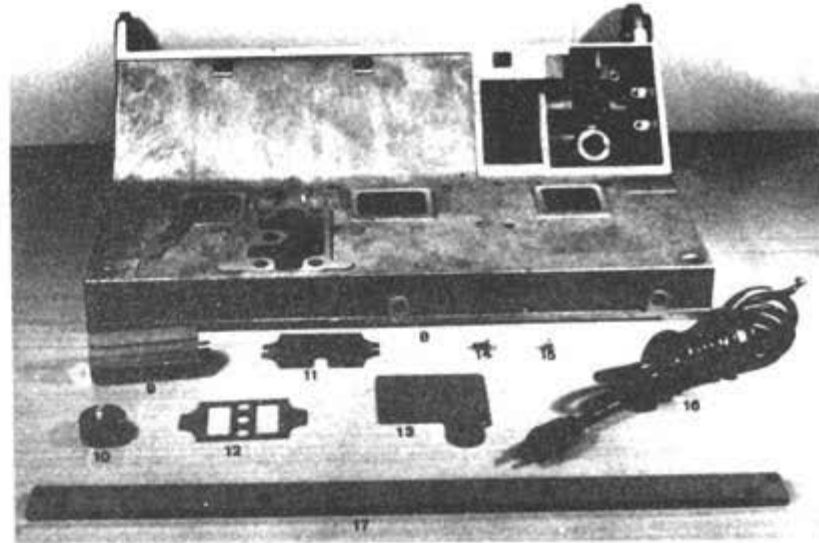
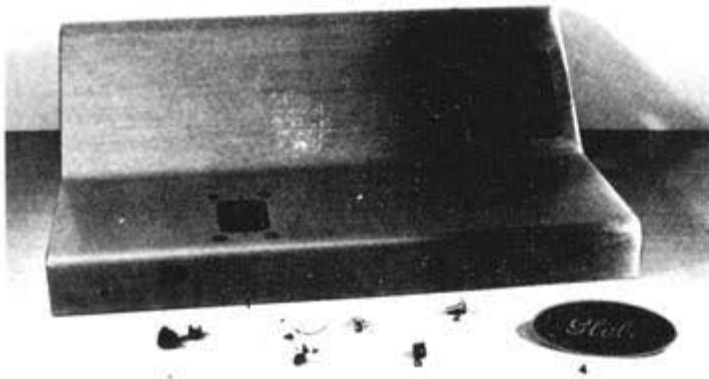

BASE PARTS

ITEM	DESCRIPTION	MODEL	MODEL	MODELS	MODELS
		500L	725L	775L/ 875L	825L, 850L
1	Base Shroud (SST)	953	960	880/960	900
2	Base Shroud Screw	851-1	851-1	851-1	851-1
3	Base Shroud Nut	851-3FN	851-3FN	851-3FN	851-3FN
4	Trade Mark Decal	505-2P	-	-	-
5	Base Shroud Plug Button	851-5	851-5	851-5	851-5
6	Slide Rod Oil Hole Bushing	243-1	243-1	243-1	243-1
7	Attachment Cord Strain Relief	877	877	877	877
8	Base	850-DC	850-DC	850-DC	850-25
9	Base Foot Extension	873	873	873	873
10	Base Pad (Rubber Feet)	817	817	817	817
11	Base Cover Plate	852	852	852	852
12	Base Cover Plate Support	852-2	852-2	852-2	852-2
13	Base Terminal Box Cover	852-4	852-4	852-4	852-4
14	Base Support Rib Screw (LR = PT.# 834-S)	850-2	850-2	850-2	850-2
15	Base Terminal Box Cover Screw	852-1	852-1	852-1	852-1
15	Base Cover Plate Screw	852-1	852-1	852-1	852-1
16	Attachment Cord	132-3	132-3	132-3	132-3
17	Base Support Rib	850-1	887	887	887
NOT SHOWN	Base Cover Plate Bushing	852-3	852-3	852-3	852-3
NOT SHOWN	Barrier Mach. Housing Gasket	867-3A	867-3A	867-3A	867-3A
NOT SHOWN	Spanish Warning Decal	851-6S	851-6S	851-6S	851-6S
NOT SHOWN	Warning Plate	851-7	851-7	851-7	851-7
NOT SHOWN	Warning Plate Drive Pin	8516P	8516P	8516P	8516P

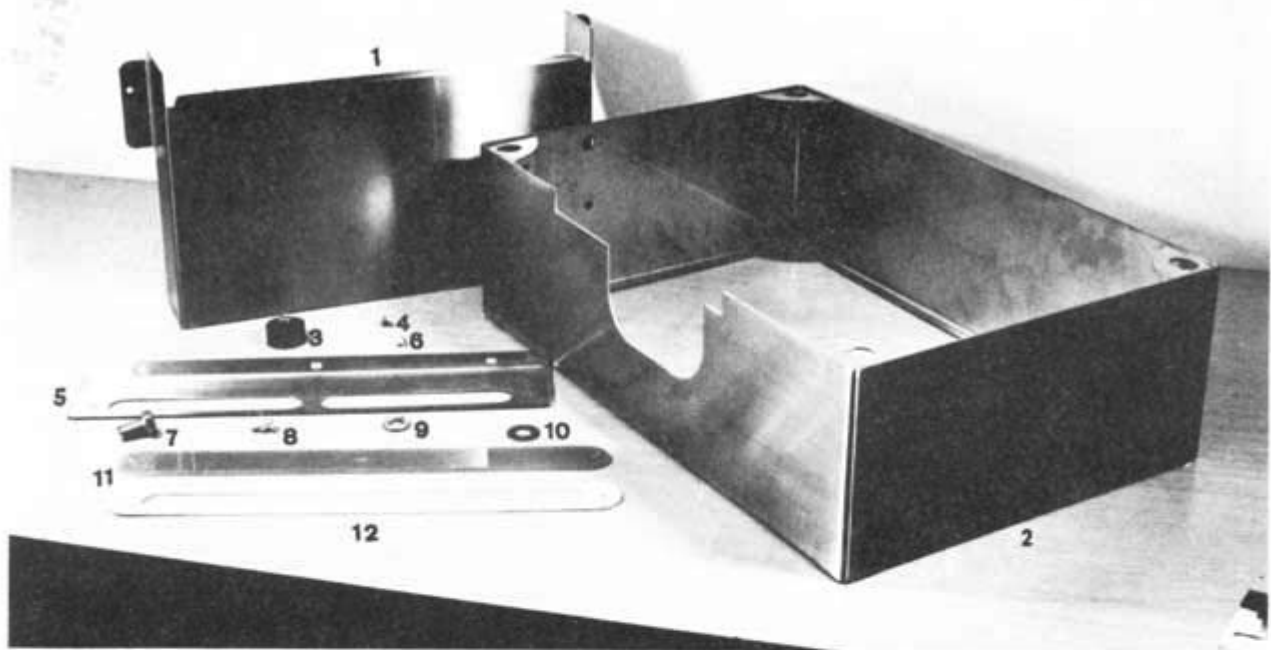

AUTOMATIC SLICER BASE PARTS

ITEM	DESCRIPTION	MODEL 725L	MODEL 775L	MODEL 825L	MODELS 875L/ 850L
1	Chain Guard	917	917-ZM	917	917
2	Base Apron (Must order Face Plate part #952-7)	923	881	902	923/922
3	Base Mounting Pad	817	817	817	817
4	Top Chain Guard Mounting Screw	889	889	889	889
5	Top Chain Guard	910-A	910-A	910-A	910-A
6	Chain Guard Window Screw	911-4	911-4	911-4	911-4
7	Apron Securing Bolt	813	813	813	813
8	Chain Guard Screw	917-2	917-2	917-2	917-2
9	Apron Securing Bolt Lock Washer	815	815	815	815
10	Apron Securing Bolt Washer	881-4	881-4	881-4	881-4
11	Chain Guard Window	911-2	911-2	911-2	911-2
12	Chain Guard Window Gasket	911-3	911-3	911-3	911-3
NOT SHOWN	Chain Guard Screw Washer	911-5	911-5	911-5	911-5
NOT SHOWN	Cotter Pin	390	390	390	390

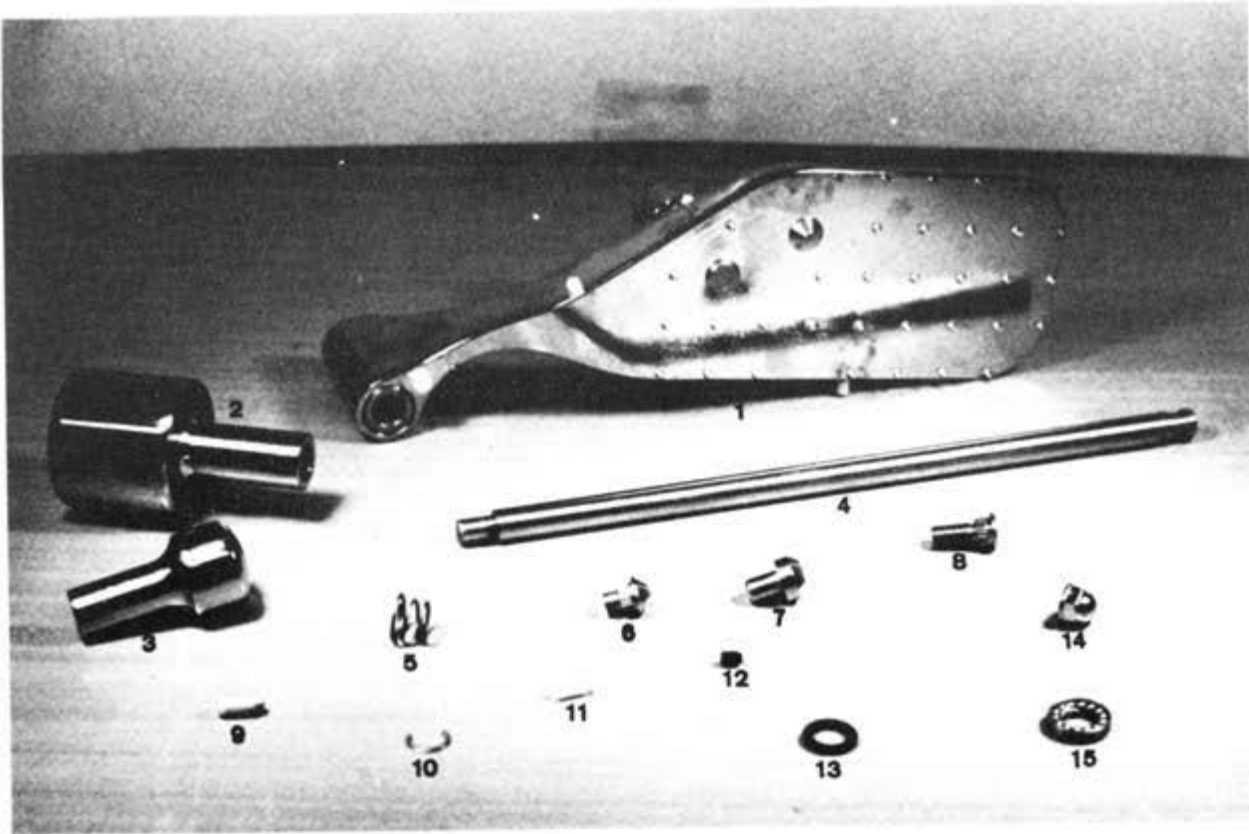

END WEIGHT PARTS WITHOUT PRONGS

ITEM	DESCRIPTION	MODEL 500L	ALL AUTOMATICS
1	End Weight Assembly	741-AS	-
2	Heavy End Weight Handle (Optional) (1-5 Lbs.)	741-3H	741-3H
2	End Weight Handle (Optional) (3 Lbs.)	934	934
3	End Weight Handle (Standard)	741-3	741-3
4	End Weight Rod For Aluminum Chute	741-1	741-1
	End Weight Rod For Short SST Chute	741-1S	741-1S
	End Weight Rod For Long SST Chute	741-1L	741-1L
5	End Weight Spring For Aluminum Chute	306-1	306-1
	End Weight Spring For SST Chute	306-2	306-2
6	End Weight Lock Stud	741-2A	741-2A
7	End Weight Lock Button on Chute Support (12")	499	499
7	End Weight Plastic Lockback (17" chute)	-	741-1H-AS
8	End Weight Handle Stud	741-3A	741-3A
9	End Weight Cam Bumper	741-4A	741-4A
10	End Weight Rod Clip For Aluminum Chute	487-3	487-3
	End Weight Rod Clip For SST Chute	741-1R	741-1R
11	End Weight Bumper 7/16"	741-5A	741-5A
12	End Weight Rod Chute ScREW (Alum. Chute)	700-3	487-1
13	End Weight Adjusting Washer (Fiber Spacer)	307-1	307-1
14	End Weight Lock Nut	741-2B	741-2B
15	End Weight Bushing	-	741 - APCH
NOT SHOWN	End Weight Bumper 9/16"	741-5B	-

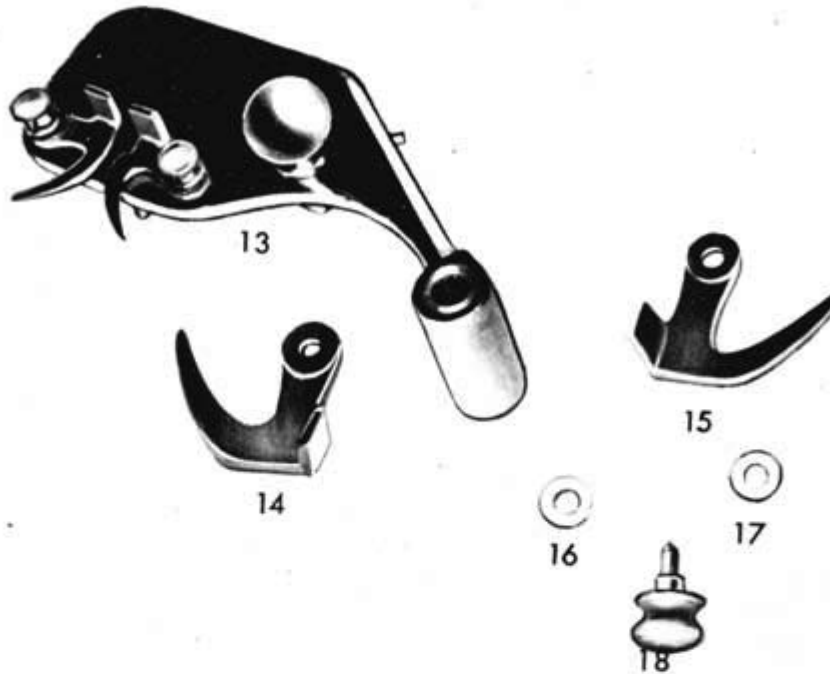

AUTOMATIC END WEIGHT PARTS WITH PRONGS

ITEM	DESCRIPTION	ALL AUTOMATIC MODELS
13	End Weight Assembly (Without Webb) (12" Chute)	741-PC-AS
13	End Weight Assembly (With Webb) (12" Chute)	741-APC-AS
13	End Weight Assembly (17" Chute)	941-PC-AS
14	End Weight Prong-Left	741-PC3
15	End Weight Prong-Right	741-PC2
16	End Weight Prong, Screw Spring Washer	741-PC5
17	End Weight Prong Screw Washer	741-PC6
18	End Weight Prong Wing Screw	741-PC7
NOT SHOWN	End Weight Insert	741-PC1
NOT SHOWN	End Weight Lock Back Hole Guard	741-APCH
NOT SHOWN	End Weight Anchor (Long Chute)	

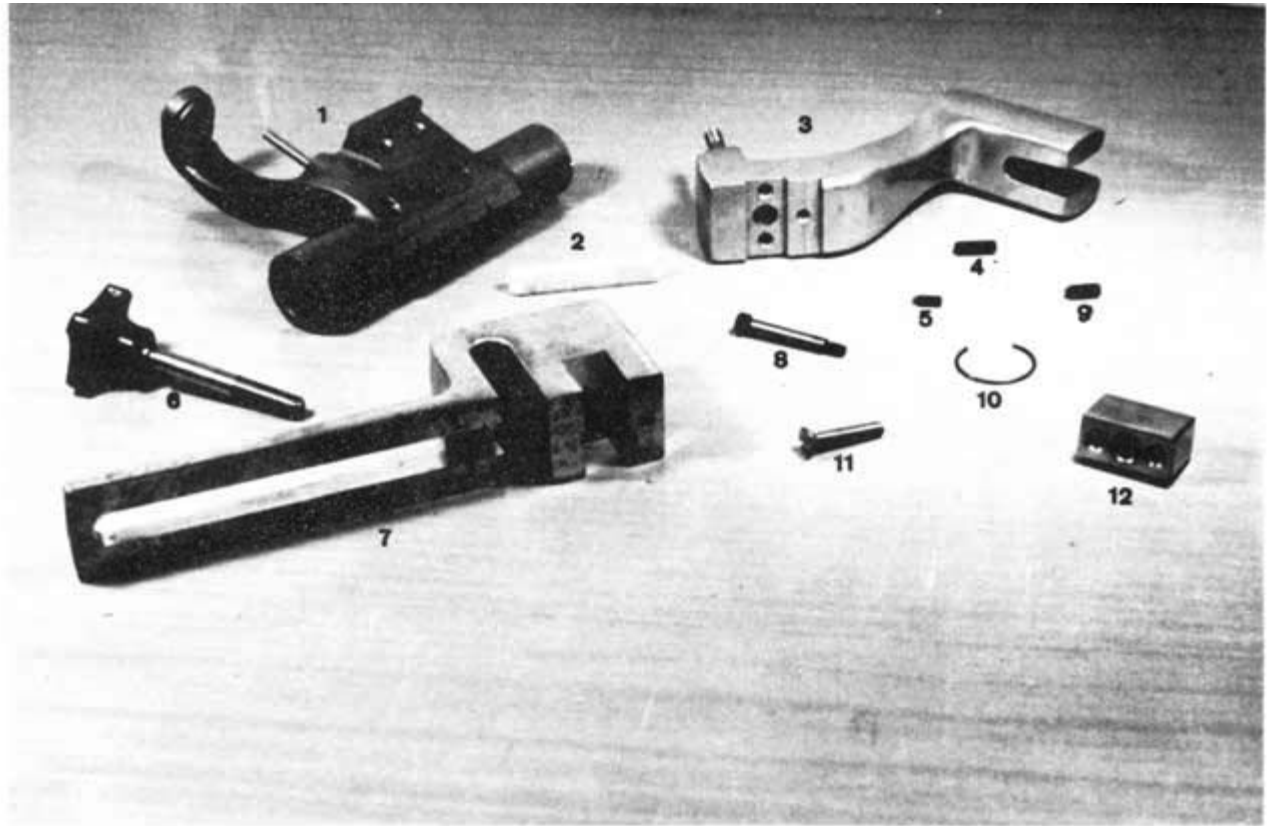

AUTOMATIC CHUTE DRIVE

ITEM	DESCRIPTION	MODEL 725L	MODEL 825L	MODEL 775L
1	Slide	436-B	436-B	436-B
2	Slide Oil Felt-Upper	436-3	436-3	436-3
3	Slide Chute Receiver	O-883	O-883	O-883
4	Chute Adjusting Screw	167-1	167-1	167-1
5	Chute Adjusting Set Screw	168-1	168-1	168-1
6	Chain Slide Knob Assembly	909-1	909-1	909-1
7	Chain Slide	909	909	909
8	Chain Slide Stop Screw	909-2	909-2	909-2
9	Chain Slide Stud Set Screw	830-2	830-2	830-2
10	Slide Oil Felt Spring Clip	436-4	436-4	436-4
11	Slide Chute Receiver Cross Bar Screw	831-1	831-1	831-1
12	Slide Chute Receiver Cross Bar	831	831	831
NOT SHOWN	Slide Bumper	918	918	918
NOT SHOWN	Slide Spring Bumper	919-1	919-1	919-1

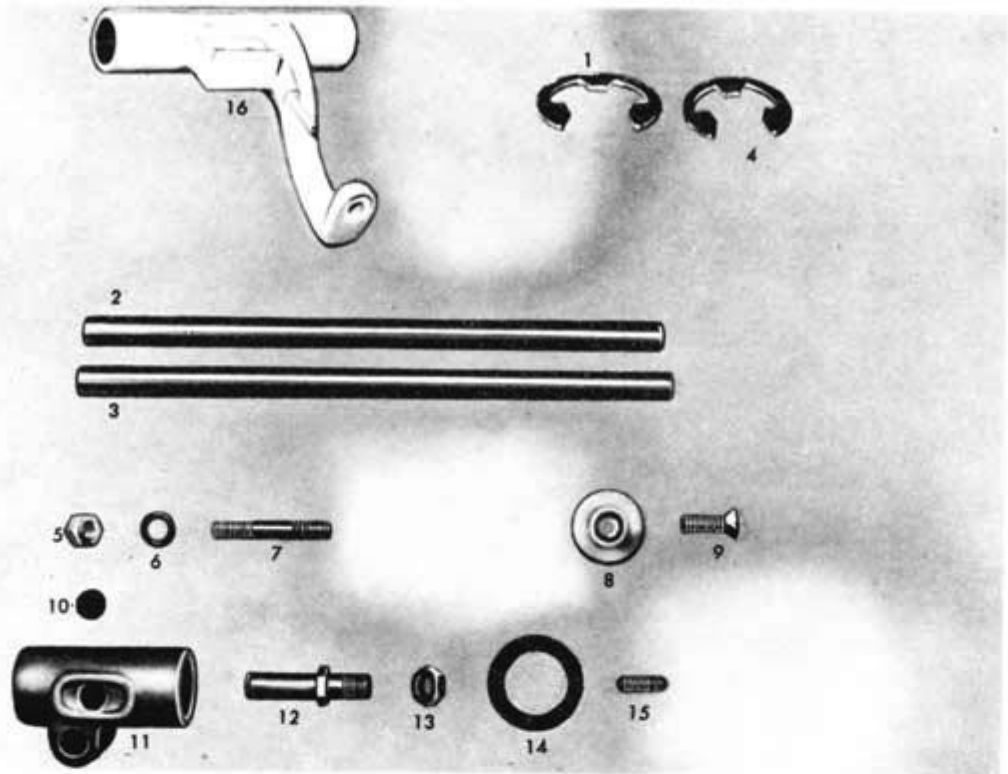

SLIDE PARTS

ITEM	DESCRIPTION	ALL MODELS
1	Slide Bar Retaining Clip (Upper)	857-1
2	Slide Bar -- Upper	857
3	Slide Bar -- Lower	858
4	Slide Bar Retaining Clip (Lower)	858-1
5	Slide Stud Bolt Nut	478-1
6	Slide Stud Bolt Lock Washer	245-A
7	Slide Stud Bolt	478
8	Slide Rod Steel Washer	859
9	Slide Rod Screw	859-1
10	Slide Oil Felt For Bushing	170
11	Slide Rod Bushing	449
12	Slide Rod Bushing Stud	241-B
13	Slide Rod Bushing Nut	228
14	Slide Bumper	436-1
15	Slide Chute Receiver Adjusting Screw	167-1
16	Slide	436-B
NOT SHOWN	Slide Oil Felt -- Upper (In Slide)	436-3

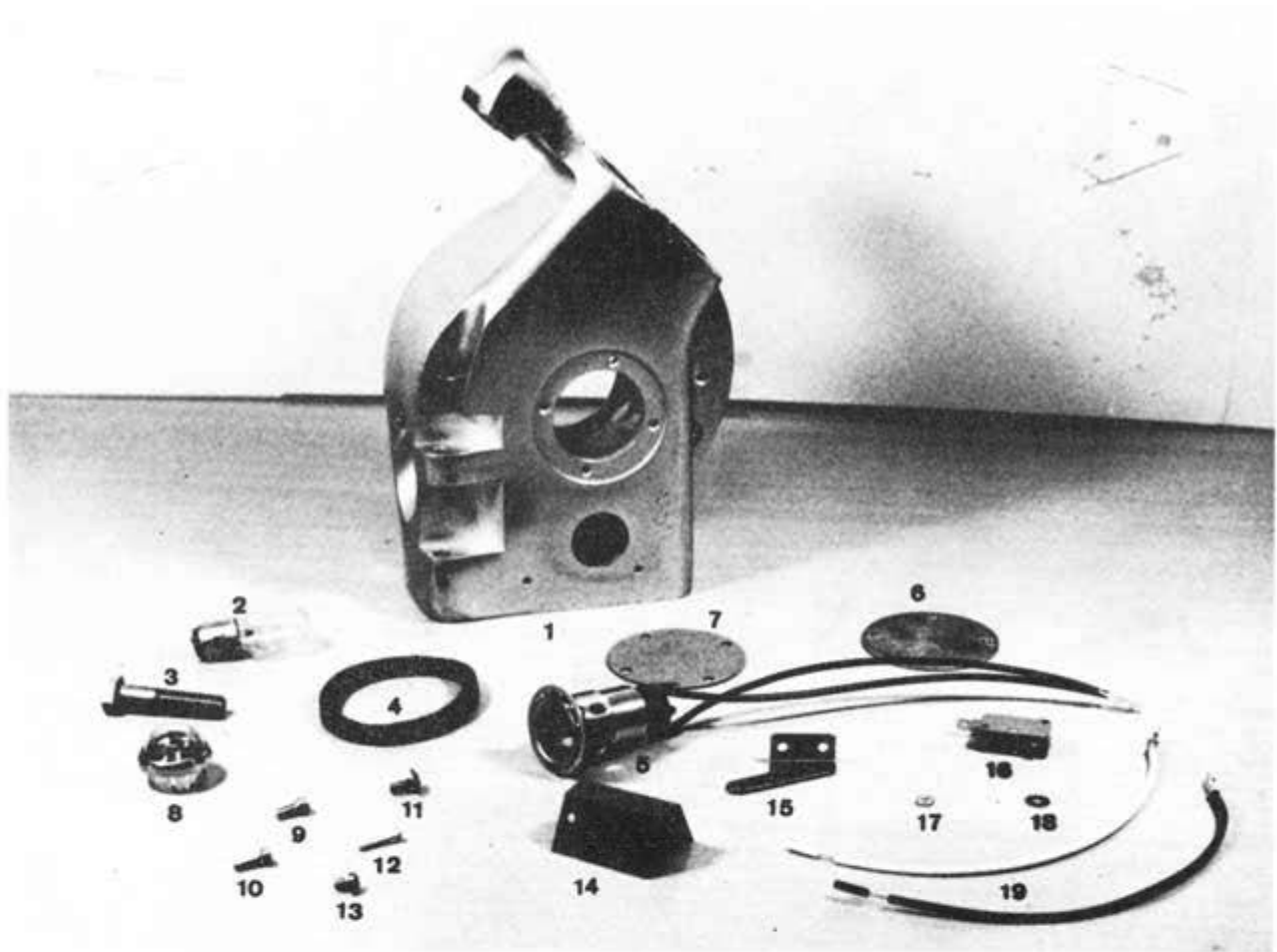

GEAR HOUSING PARTS

ITEM	DESCRIPTION	ALL MODELS
1	Gear Housing (L or LR)	827-R
2	Pilot Light Lamp 220 Volt #10S6	710-2
	115 Volt #10C7	710-1
3	Gear Housing Screw	369-1
4	Gear Housing Felt	370
5	Pilot Light Lamp	710
6	Gear Housing Cover	391-2
7	Gear Housing Cover Gasket	391-3
8	Pilot Light Lens	712
9	Receiving Tray Retainer Screw	856-4
10	Interlock Switch Plunger	854-8
11	Gear Housing Cover Screw	331-2
12	Interlock Switch Screw	854-2
13	Interlock Switch Bracket Screw	854-6
14	Interlock Switch Insulating Fibre	854-4
15	Interlock Switch Bracket	854-5
16	Interlock Switch Microswitch	854-1
17	Interlock Switch Screw Nut	854-3
18	Interlock Switch Screw Washer	854-7
19	Interlock Switch Wire Harness	854-9
NOT SHOWN Slice Deflector Hinge Pin (Lower)		739-3

Gear Housing assembly includes all parts pictured.....827-R-AS

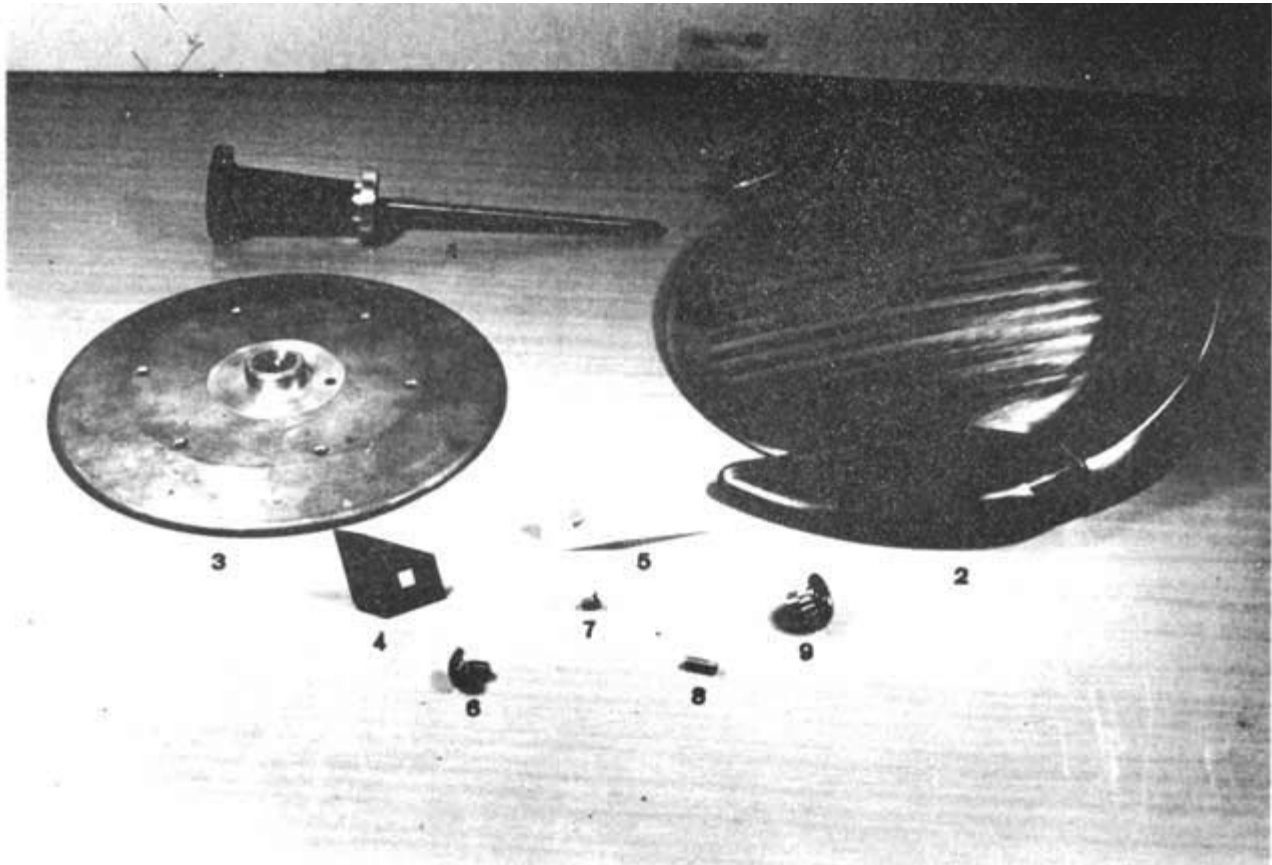

KNIFE GUARD PARTS

ITEM	DESCRIPTION	ALL "L" MODELS	ALL "LR" MODELS
1	Knife Guard Interlock Stud Knob Assembly	879-AS	879-AS
2	Center Plate - Knife Guard "L"	915-5	-
	Center Plate - Knife Guard "LR"	-	955-1
3	Knife Center Plate Support	384-3-AS	955-2
4	Scraper Blade Clamp	829-1	-
5	Scraper Blade	829-2	-
6	Scraper Blade Screw	829-3	-
7	Knife Center Plate Screw	261 (6 required)	955-3 (4 required)
8	Knife Guard Stop Pin	822-5	822-5
9	Scraper Blade Nut	829-4	-

Note: For Complete Assemblies, See Page # 1

KNIFE & KNIFE HUB ASSEMBLY

ITEM	DESCRIPTION	MODELS 500L 725L, 775L & 825L
NOT SHOWN	Carbon Steel Knife	746
NOT SHOWN	Stainless Steel Knife	746SS
1	Knife Plate Hub Assembly (Fibre Gear)	932-AS
1	Knife Plate Hub Assembly (Bronze Gear)	932-AS-1
2	Knife Plate Hub	932
3	Knife Shaft Nut	747-8
4	Knife Gear Snap Ring	747-16
5	Knife Plate Coupling Seal	932-4
6	Gear Housing Felt	370
7	Bronze Knife Gear	747-17B
8	Fibre Knife Gear	747-17
9	Steel Motor Gear	373
10	Gear Key	747-18
11	Knife Plate Coupling Retainer Ring	747-19
12	Knife Plate O-Ring	932-1
13	Knife Plate Coupling	932-3
14	Knife Plate Coupling Key	747-11
15	Knife Plate Coupling Set Screw	747-12
16	Knife Plate Coupling Shim	932-10
17	Knife Plate Bearing Locknut	747-14
18	Knife Plate Bearing Lock Washer	747-13
19,20	Knife Plate Bearing Set (Cup & Cone)	747-5
21	Knife Plate Bearing Shim	747-6
22	Knife Plate Bearing Spacer - Small	932-8
23	Knife Plate Bearing Spacer - Large	932-7
24,25	Knife Plate Bearing (Cup & Cone)	747-5
26	Knife Plate Washer	747-7
27	Knife Shaft	932-2
NOT SHOWN	Bearing Grease (Food Grade) 1 lb.	521

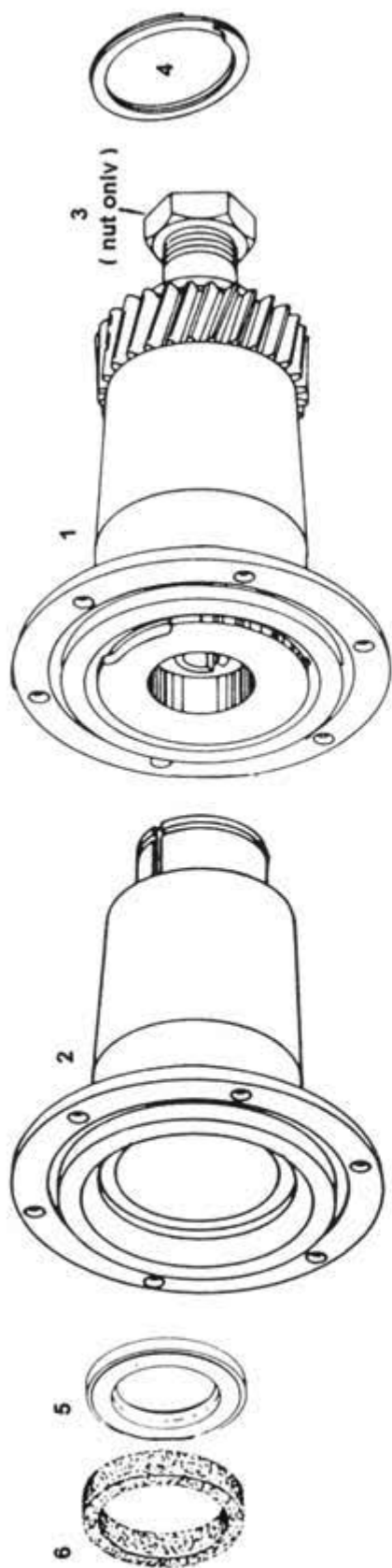

SOLID KNIFE HUB COMPONENTS

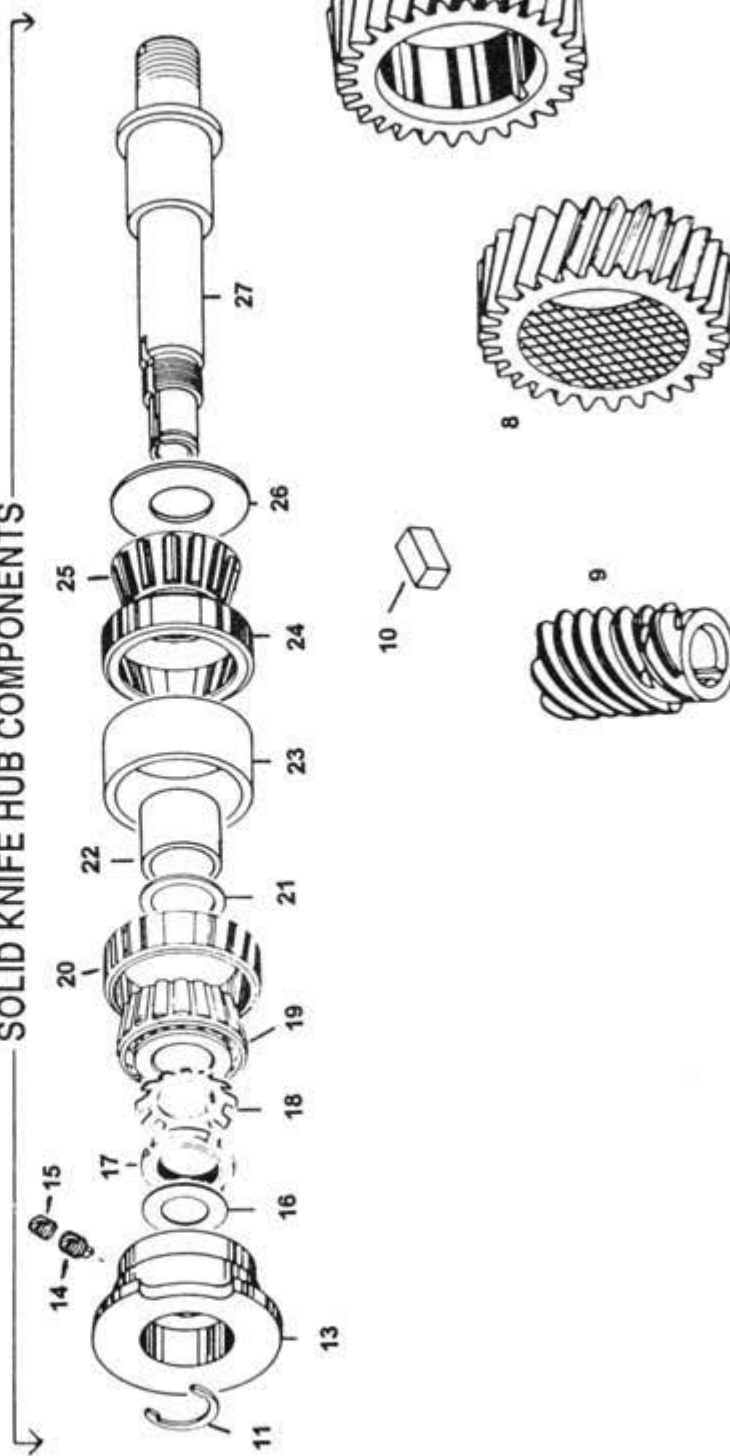

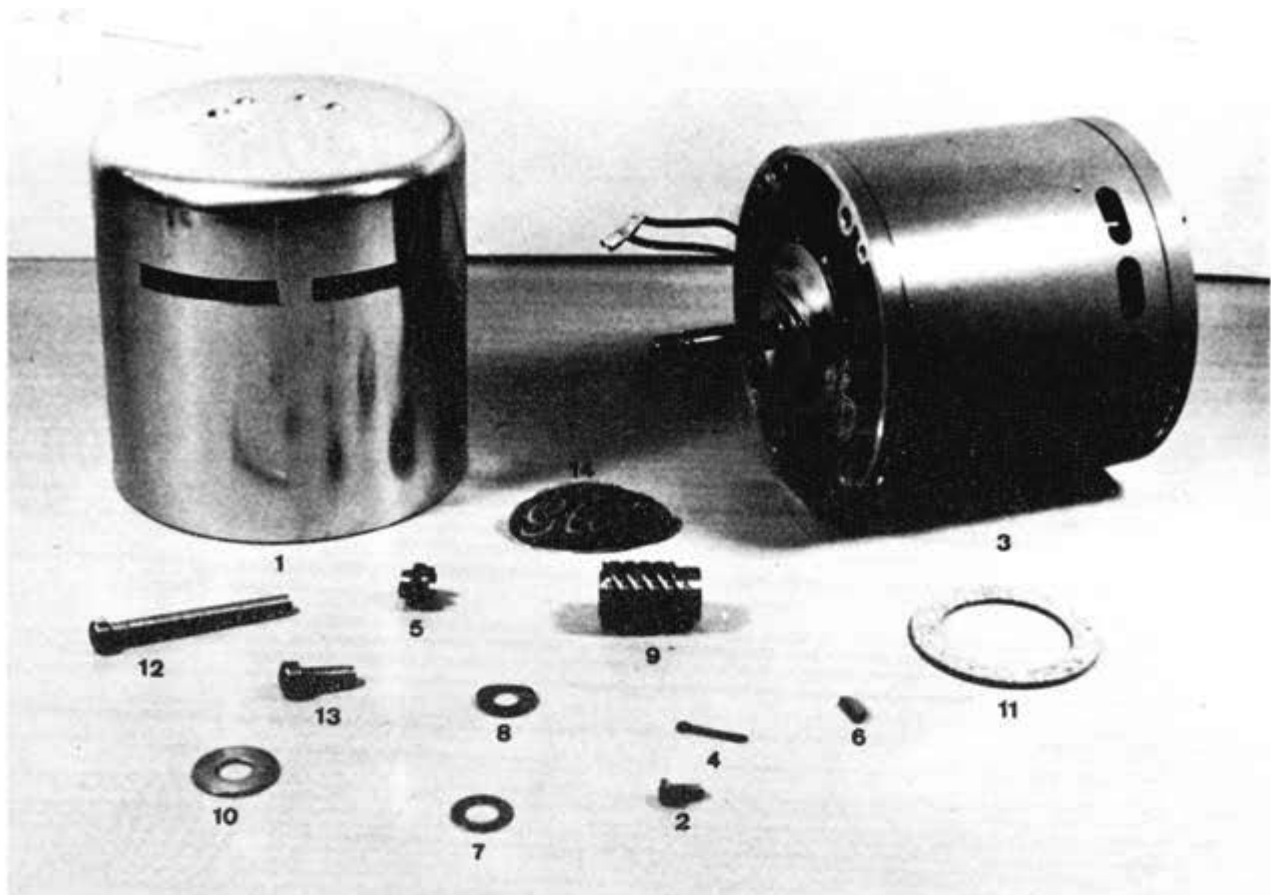

KNIFE MOTOR PARTS

ITEM	DESCRIPTION	MODEL 500L	MODELS 725L, 825L, 775L
1	Motor Shell	796-S	796-S
	Motor Shell With Overload Hole and 796-D Hole cover #2196-S	796-C	796-C
2	Motor Shell Screw	834-S	796-2
3	Motor 115/60/1.33 HP * For Special Motors, Contact Factory.	834-1	834-1
4	Motor Shaft Cotter Pin	390	390
5	Motor Shaft Nut	808	808
6	Motor Shaft Key	375-A	375-A
7	Motor Gear Washer (Large Flat) (2 required)	375	375
8	Motor Gear Bowed Washer (4 required)	810	810
9	Motor Gear	373	373
10	Motor Gear Flat Washer	809	809
11	Motor Cork Washer (Gasket)	395	395
12	Motor Screw (Long) (1 required)	795-L	795-L
13	Motor Screw (Short) (2 required)	795-S	795-S
14	Motor Shell Decal	871-2	871-2

When ordering any part of a motor, Specify Voltage, Phase, Cycle, H.P., Make & Model Number.
Give Slicer Serial Number whenever available.

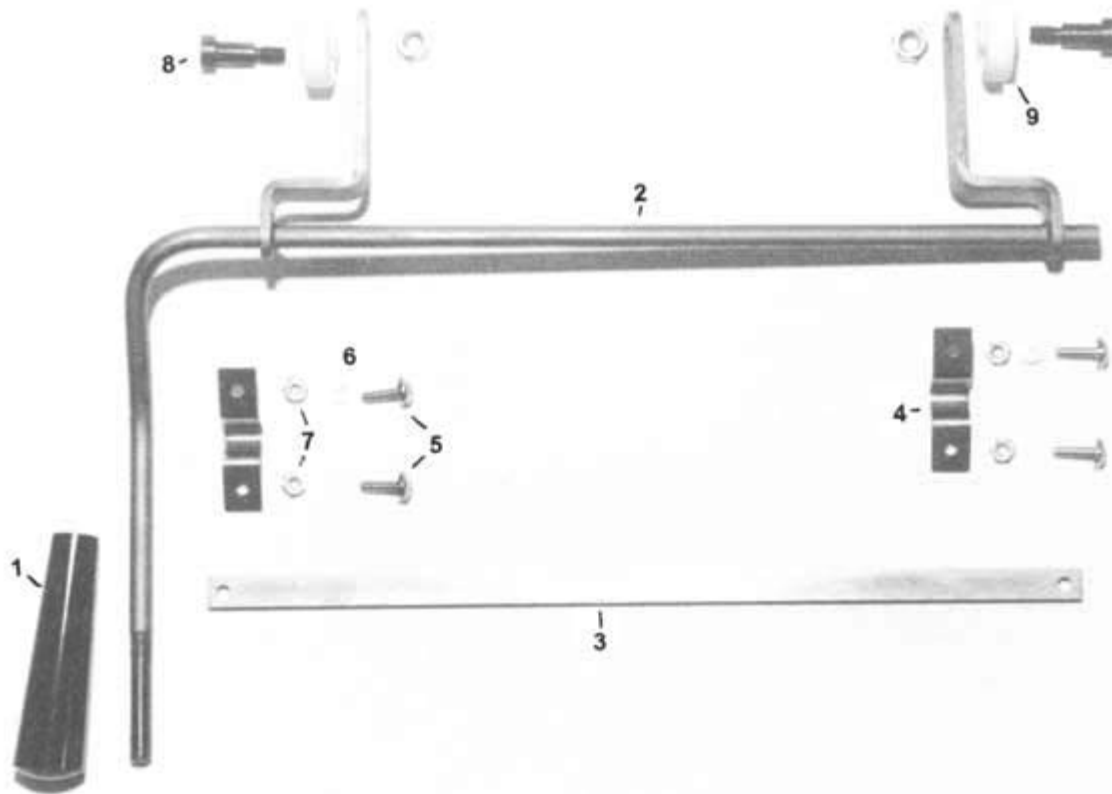

AUTOMATIC SLICER LIFT LEVER

ITEM	DESCRIPTION	ALL AUTOMATICS WITH RECEIVING TRAYS	EXTENDED BASE AUTOMATICS WITHOUT TRAYS
-	Lift Lever Assembly (all parts) Includes Template & Instructions	951-AS	951-ASW
1	Knob	951-8	951-8
2	Lift Lever	951-3	951-3W
3	Stop Bar	951-6	951-6
4	Pivot Rod Clip	951-2	951-2
5	Screw, 10-24 x 3/4"	350	350
6	Lock Washer #10	925-26	925-26
7	Hex Nut 10-24	760-5	760-5
8	Shoulder Screw	951-5	951-5
9	Roller	951-7	951-7
NOT SHOWN Hex Nut for Shoulder Screw		478-1	478-1
NOT SHOWN Drill Template for Mounting Lift Lever		951-9	951-9

SHARPENER PARTS

ITEM	DESCRIPTION	ALL MODELS
1	Sharpener Wheel Nut	228
2	Sharpener Wheel Washer (Steel)	229
3	Sharpener Wheel Washer (Fibre)	229-1
4	Sharpener Inside Wheel (Truing)	213
5	Sharpener Outside Wheel (Sharpening)	214-A
6	Sharpener Inside Shaft Assembly	467-AS
7	Sharpener Outside Shaft Assembly	463-AS
8	Sharpener Hinge Bolt Nut	286
9	Sharpener Bracket	448
10	Sharpener Housing	450-H
11	Sharpener Lock Rod Assembly	456-AS
12	Sharpener Lock Spring	458
13	Sharpener Gear	455
14	Sharpener Gear Returning Spring	460
15	Sharpener Gear Spacer Ring	459
16	Sharpener Gear Spacer Ring Screw	459-1
17	Sharpener Handle	495
18	Sharpener Handle Set Screw	495-1
19	Sharpener Lock Knob	461
20	Sharpener Lock Rod Knob Pin	287-2
21	Sharpener Bracket Clamp Screw Washer	134
22	Sharpener Hinge Bolt Washer	286-1
23	Sharpener Bracket Clamp Screw	477
24	Sharpener Hinge Bolt	475
25	Sharpener Sleeve Pin	300
26	Sharpener Stop Bushing Screw	470-1
27	Sharpener Inside Wheel Stop Assembly	471-AS
28	Sharpener Cover	825
NOT SHOWN	Sharpener Cover Hinge Screw	825-1
NOT SHOWN	Sharpener Cover Hinge Screw Washer	825-2
NOT SHOWN	Sharpener Cover Hinge Nut	825-3
NOT SHOWN	Sharpener Cover Decal	825-4S

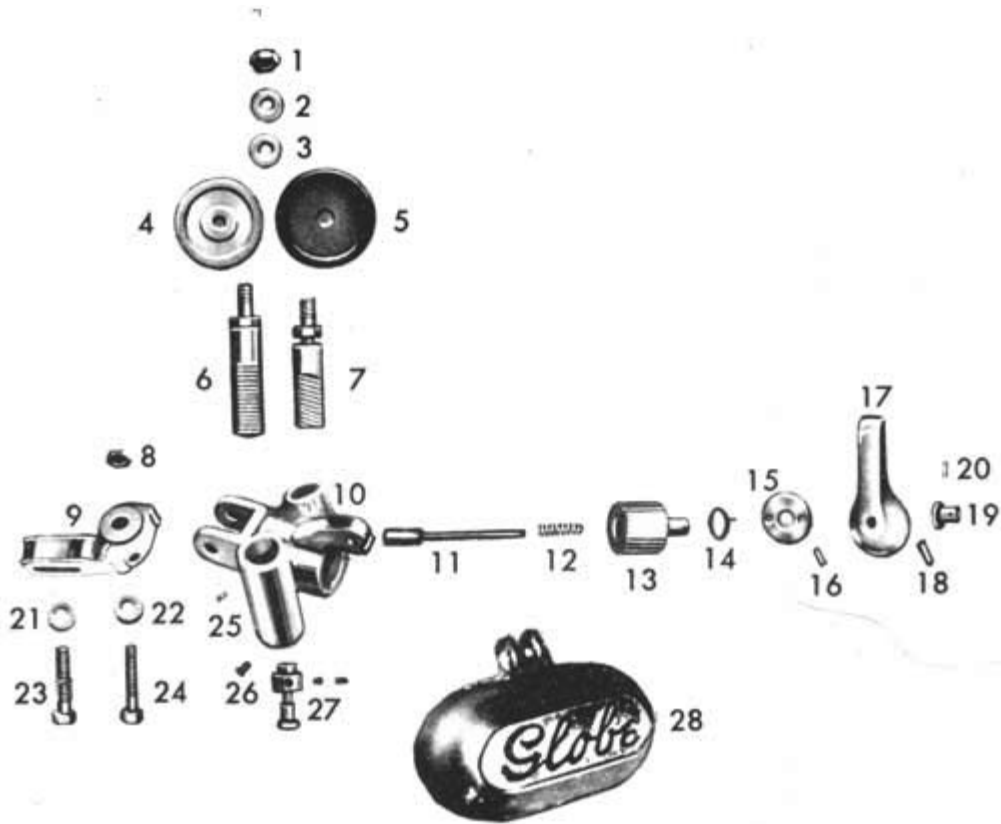

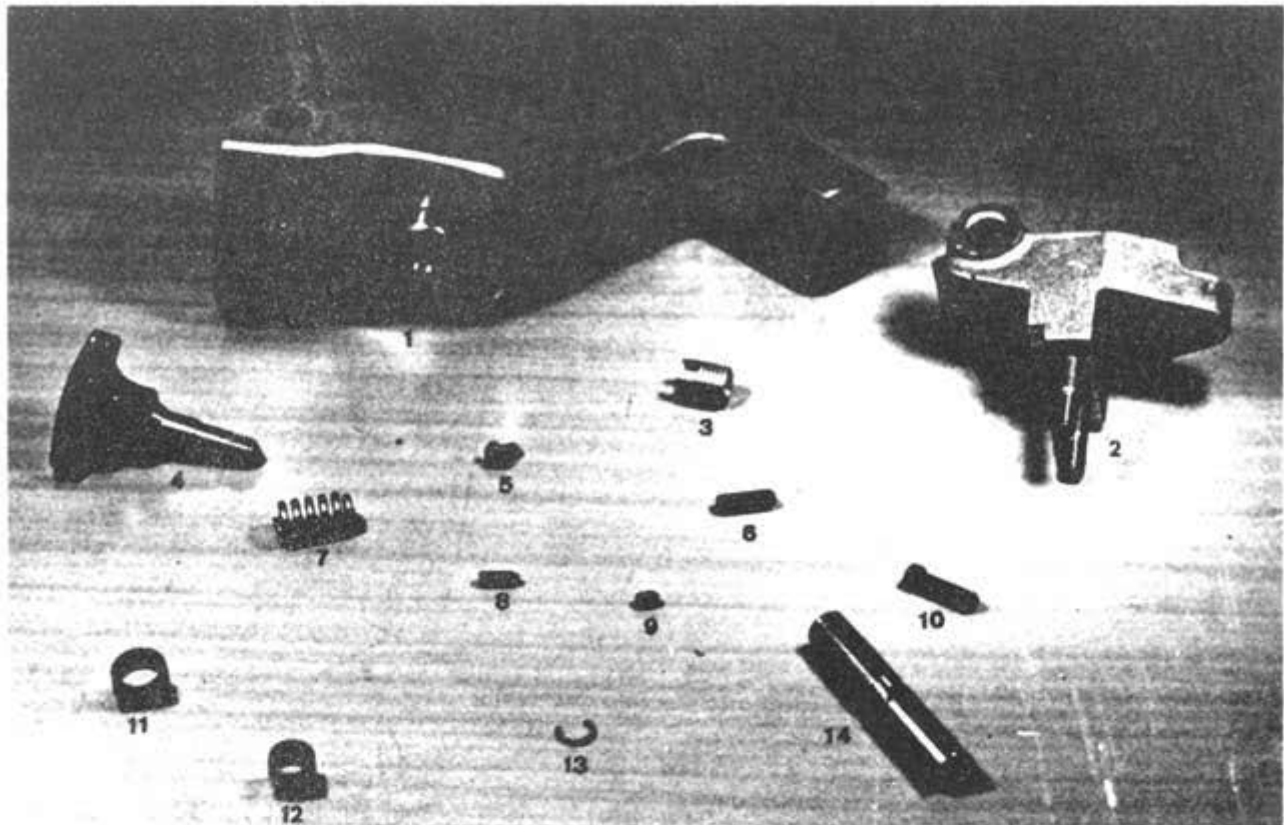

ARM & HINGE ASSEMBLIES FOR THE 500L & 500LR

ITEM	DESCRIPTION	MODELS 500L & 500LR
1	Chute Arm Assembly (Entire Page)	853-AS
1	Chute Arm with bushing #700-1, 703-1	853-AS1
2	Slide Chute Arm Hinge	700
3	Chute Arm Hinge Insert -- Threaded Bushing	700-1
4	Chute Arm Knob Assembly	707-B
5	Chute Arm Spring Screw	709-1
6	Chute Adjusting Screw	167-1
7	Chute Arm Spring	709
8	Chute Adjusting Set Screw	168-1
9	Slide Chute Arm Hinge Stop Set Screw	700-3
10	Slide Chute Arm Hinge Stop Screw	700-2
11	Chute Arm Hinge Pin Bushing (Sintered Bronze)	853-2
12	Chute Arm Bushing Sleeve	703-1
13	Chute Arm Knob Retaining Ring	708
14	Chute Arm Hinge Pin	704
NOT SHOWN	Chute Arm Hinge Pin Set Screw	706
NOT SHOWN	Slide Chute Arm Hinge Assembly (Includes 2, 9, 10 & 11)	700-AS

LUBRICATING OIL

ITEM	DESCRIPTION	PART NUMBER
1	4 oz. Can of Lubricating Oil	519



RECEIVING TRAY PARTS

ITEM	DESCRIPTION	ALL MODELS EXCEPT THE 825L & 850L
1	Receiving Tray	856
2	Receiving Tray Retaining Knob	856-2
3	Receiving Tray Retaining Knob Screw	856-3
NOT SHOWN	Base Shroud Flange Nut	851-3FN

TABLE ADJUSTMENT PARTS

ITEM	DESCRIPTION	ALL MODELS
1	Table Support	862
2	Table (Stainless Steel)	826
3	Table Mechanism Cover	866
4	Table Slide	863
5	Table Adjusting Shim (Paper)	377-A
6	Table Adjusting Knob Ball	362
7	Table Slide Set Screw	346
9	Table Adjusting Knob Screw	356-1
10	Table Mechanism Cover Bracket Screw	867-1
11	Table Mechanism Cover Bracket Nut	867-2
12	Table Knob Shaft Thrust Screw	361-1
13	Table Screw (5 required)	338
14	Table Adjusting Knob Spring	361
15	Table Adjusting Knob	407-1B
16	Table Mechanism Cover Bracket	867
17	Table Adjusting Worm	358
18	Table Adjusting Knob Shaft	864
19	Table Slide Shaft	344
20	Table Clamp Screw	862-1
21	Table Slide Guide Screw	350
22	Table Clamp Screw Washer	756-2
23	Table Mechanism Cover Screw	866-1KH
24	Table Adjusting Cam	865
25	Table Adjusting Gear Bushing Washer	363-A
26	Table Slide Guide ShimS (Specify Thkness.: .004, .007, .014, .023, .032, .042, .052)	349-A
27	Table Slide Stop Screw	493-1
28	Table Adjusting Cam Screw (Long)	353-1
29	Table Adjusting Cam Screw (Short)	353-1
30	Table Adjusting Worm Pin	360
31	Table Adjusting Worm Washer	359
32	Table Adjusting Gear Bushing Screw	335
33	Table Adjusting Gear Assembly	453-AS
34	Table Slide Guide	349
NOT SHOWN Table Mechanism Barrier		867-3A

Table Assembly includes Item Numbers 1,2 and 13.....826-AS

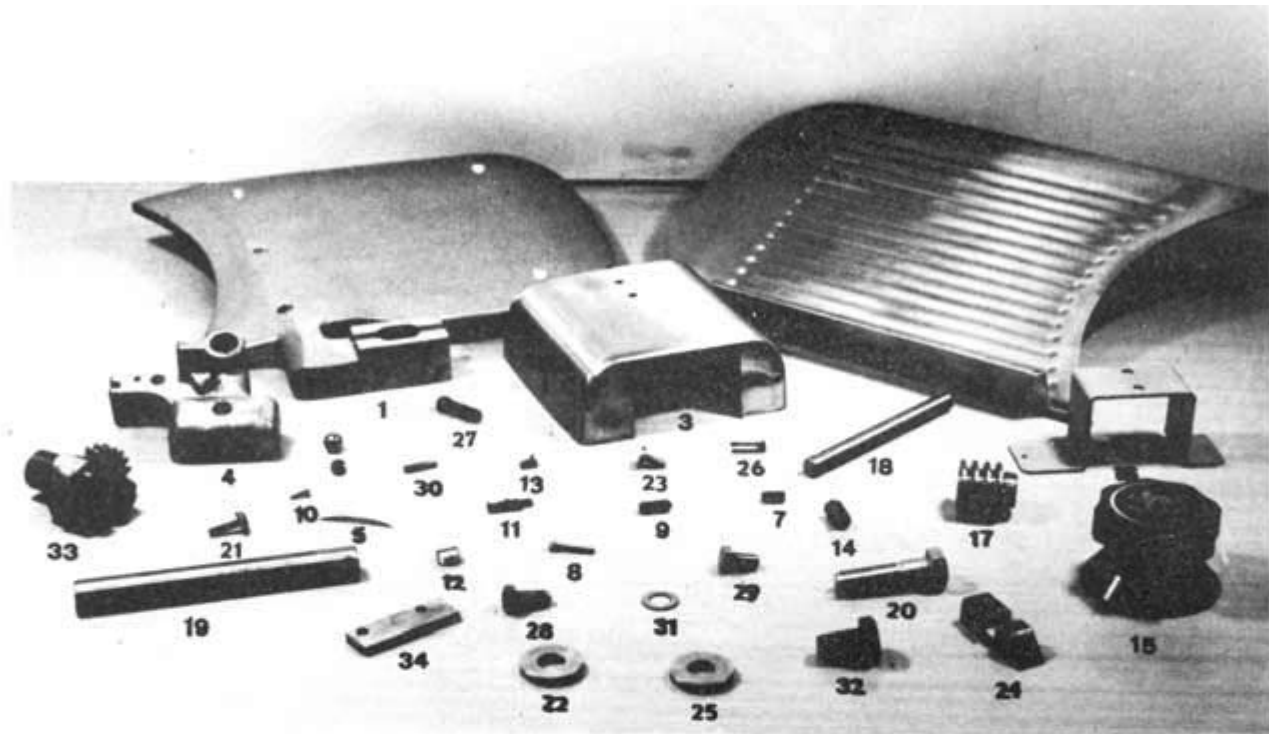

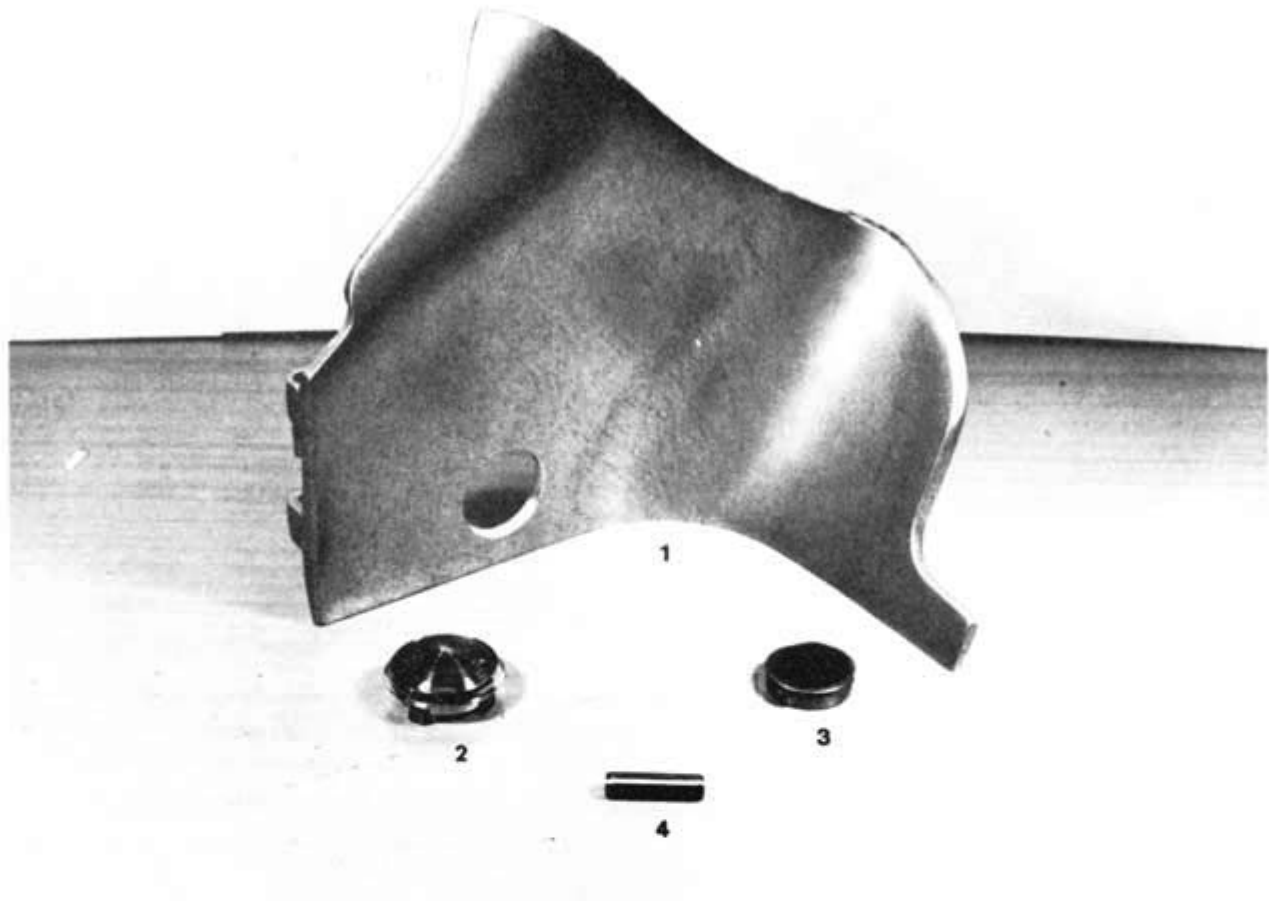

SLICE DEFLECTOR PARTS

ITEM	DESCRIPTION	ALL MODELS
1	Slice Deflector (Includes 3 & 4))	861-L-AS
2	Pilot Light Lens Cap	711
3	Slice Deflector Magnet Cap Assembly	739-AS
4	Slice Deflector Hinge Pin, Upper	739-3B

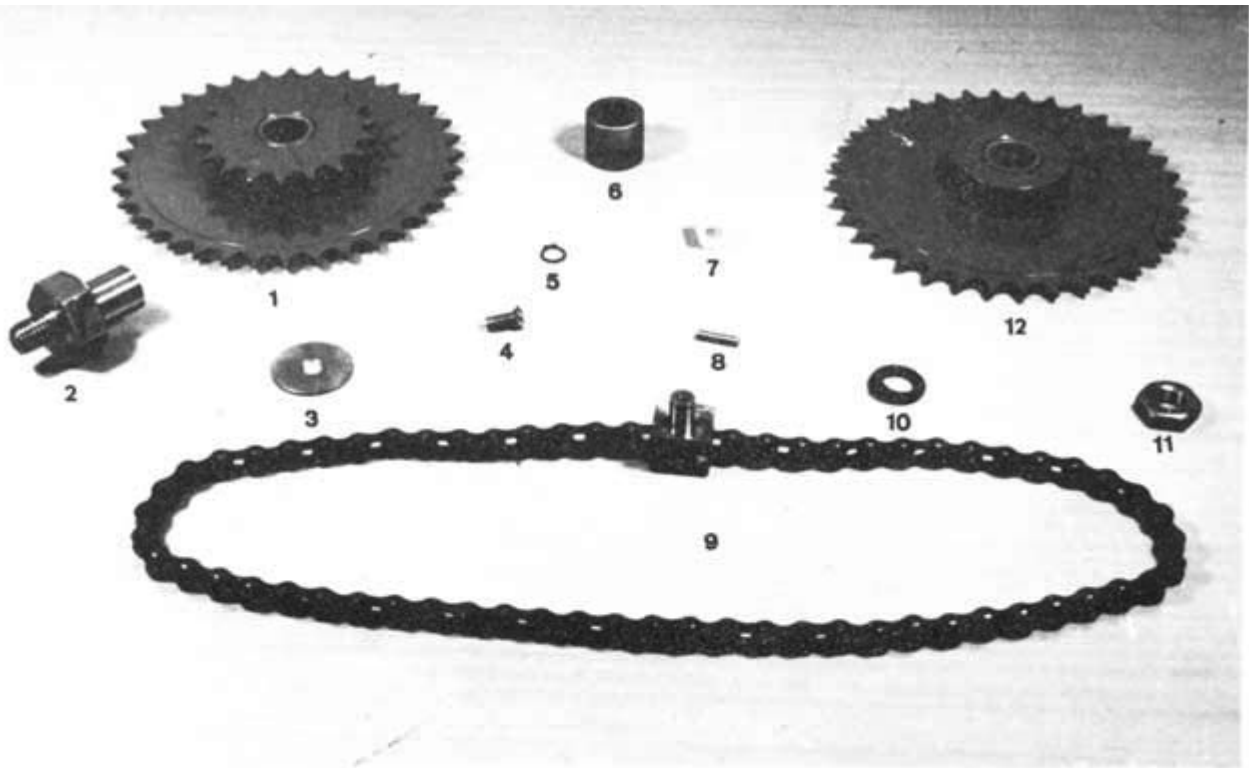

AUTOMATIC SLICER SPROCKET PARTS

ITEM	DESCRIPTION	ALL AUTOMATIC
1	Drive Sprocket Assembly (18t. & 36t.)	762-3
2	Sprocket Stud	764-12
3	Sprocket Washer	608
4	Sprocket Screw	609
5	Chain Connector Clip	766-6
6	Sprocket Bushing Bronze (used on both sprockets)	762-4
7	Chain Connector Roller	766-5
8	Chain Connector Pin	766-4
9	Drive Slide Chain -- 64 Links (assembled with Roller, Pin, Clip & Connector)	766-2BAS
10	Sprocket Stud Washer	815
11	Sprocket Stud Nut	646
12	Back Sprocket (36t.)	762-2
NOT SHOWN	Sprocket Barrier (not shown)	762-5
NOT SHOWN	Sprocket Barrier Screw (not shown)	762-6
NOT SHOWN	Chain Connector	612

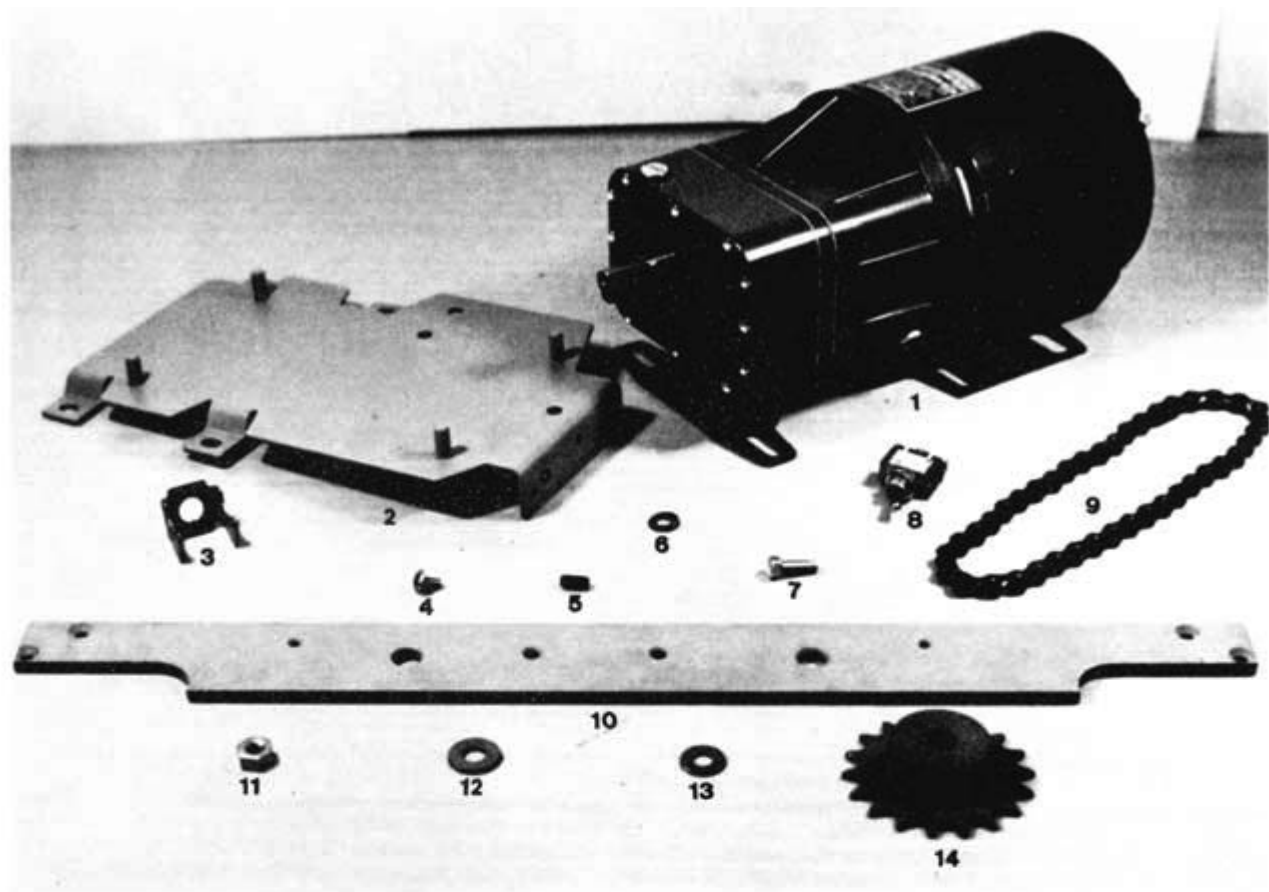

775L DRIVE SYSTEM

ITEM	DESCRIPTION	ALL AUTOMATIC
1	Zero-Max G.E. 115V/60HZ/1PH -- #SKB-79K	763-1GEZ
	Zero-Max G.E. 230V/50HZ/1PH -- #SKB-78E	763-2GEZ
2	Motor Platform, Zero-Max	888-Z
3	Switch Guard	785-1SG
4	Sprocket Stud Mount Screw	887-1
5	Sprocket Screw	346
6	Gear Motor Platform Weld Screw Lock Washer	245-A
7	Gear Motor Platform Screw	888-1
8	Z-M Motor Switch, 1 PH (Cutler-Hammer #7500K14)	648
9	Drive Chain 40 Link	766-1B
10	Sprocket Stud Mount	887
11	Gear Motor Platform Nut	478-1
12	Gear Motor Platform Weld Screw Washer	763-4A
13	Gear Motor Platform Screw Washer	888-2
14	Z-M Sprocket (18t.)	762-1
14	Z-M Sprocket (20t.)	762-2G

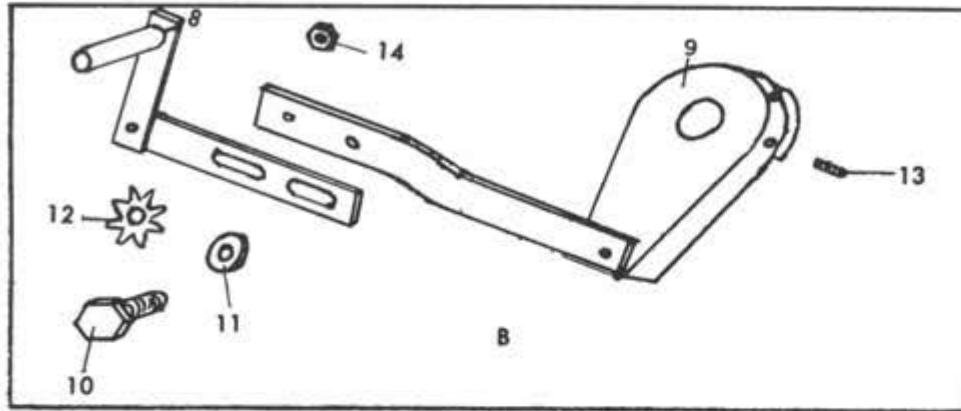
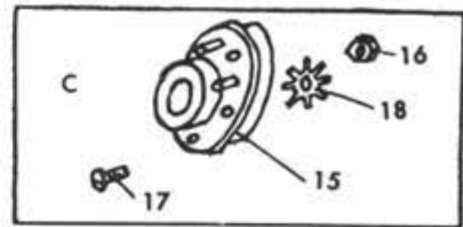
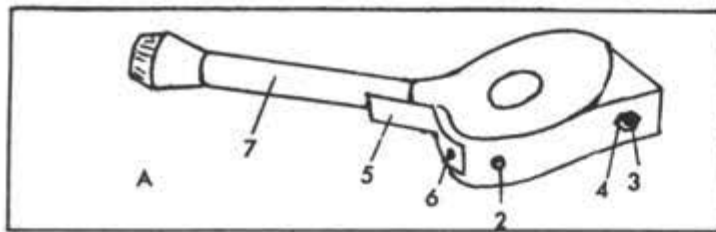

775L VARIABLE SPEED CONTROL

ITEM	DESCRIPTION	SLICER PART NUMBERS
		MODEL 775L
A	Speed Control Knob Assembly	760
2	Speed Control Knob Set Screw	760-2
3	Speed Control Knob Stop Screw	760-4
4	Speed Control Stop Screw Nut	760-5
5	Speed Control Knob Pointer	760-6
6	Speed Control Knob Pointer Screw	760-7
7	Speed Control Knob Assembly Handle	760-8
	Speed Control Decal	760-9
B	Connecting Link Assembly	761
8	Control Connecting Link Assembly	761-1AS
9	Motor Connecting Link Assembly	761-2AS
10	Connecting Link Screw	761-7C
11	Connecting Link Washer	761-7D
12	Connecting Link Lock Washer	761-7E
13	Connecting Link Arm Set Screw	761-9
14	Connecting Link Screw Nut	761-6
C	Speed Control Knob Flange Assembly	765
15	Speed Control Knob Flange	765-1
16	Speed Control Knob Flange Nut	765-5
17	Speed Control Knob Flange Screw	765-4
18	Speed Control Knob Flange Washer	765-6

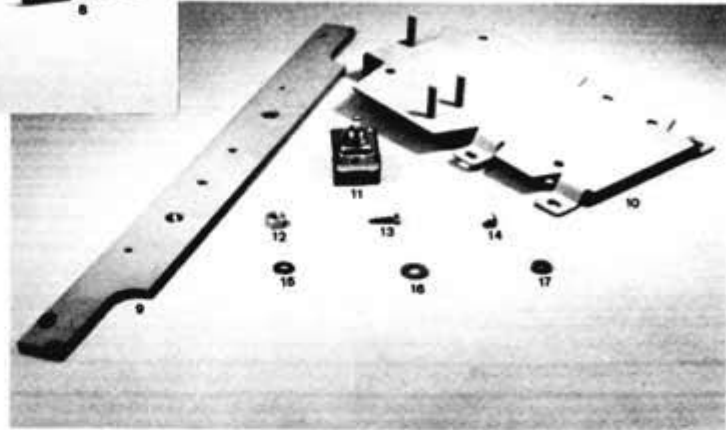
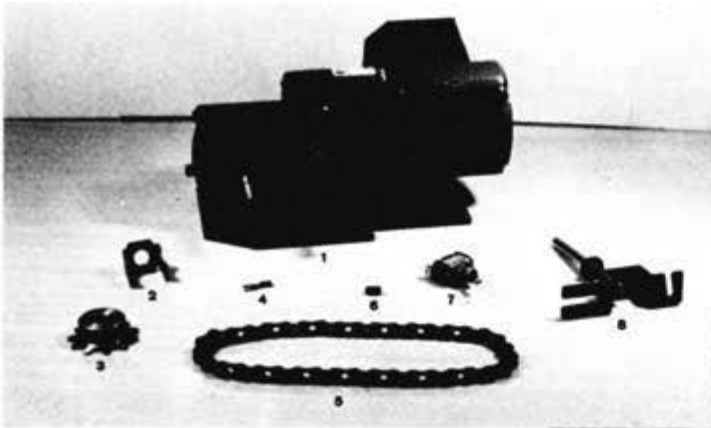

CHUTE MOTOR (Single Speed Units)

ITEM	DESCRIPTION	MODELS 725L - 825L
1	Gear Motor	908F
2	Switch Guard	785-1SG
3	Gear Motor Sprocket -- 11 Tooth - 40 Strokes (Standard)	619
	13 Tooth - 48 Strokes (Optional)	621
5	Drive Chain -- 38 Links - 40 Stroke (Standard)	892-2
	39 Links - 48 Stroke (Optional)	892-3
6	Gear Motor Sprocket Screw	606
7	Gear Motor Switch (Single Phase Only)	648
8	Gear Motor Reset Button Assembly (Doerr)	907-D
8	Gear Motor Reset Button Assembly (Franklin)	907-F
9	Sprocket Stud Mount	887
10	Gear Motor Platform (725 only)	888-A
10	Gear Motor Platform (825L only)	904
11	Gear Motor Switch (3 Phase Only)	648-1
12	Gear Motor Platform Nut	478-1
13	Gear Motor Platform Screw	887-1
14	Sprocket Stud Mount Screw	887-1
15	Gear Motor Platform Weld Screw Lock Washer	245-A
16	Gear Motor Platform Weld Screw Washer	733-3
17	Gear Motor Platform Screw Washer	888-2

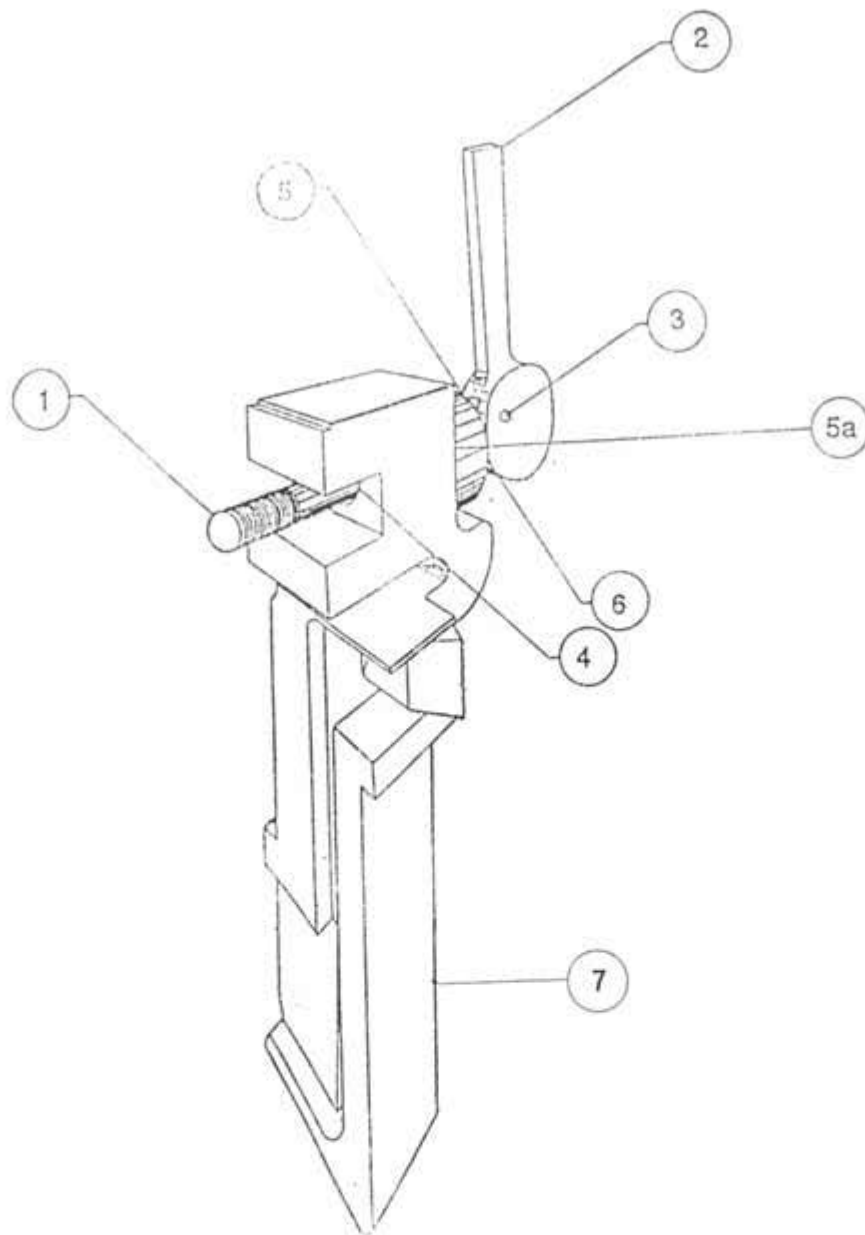

QUICK RELEASE AUTOMATIC CHAIN SLIDE

ITEM	DESCRIPTION	ALL AUTOMATIC MODELS
1	Chain Slide Eye Bolt	916-1
2	Chain Slide Cam	916-2
3	Chain Slide Cam Pin	916-3
4	Chain Slide Cam Spring	916-4
5	Chain Slide Cam Washer	916-5L
5A	Chain Slide Cam Washer Shim .005	916-5A
5B	Chain Slide Cam Washer Shim .010	916-5B
5C	Chain Slide Cam Washer Shim .020	916-5C
6	Chain Slide Cam Washer Screw	916-6
7	Chain Slide Assembly	916-AS

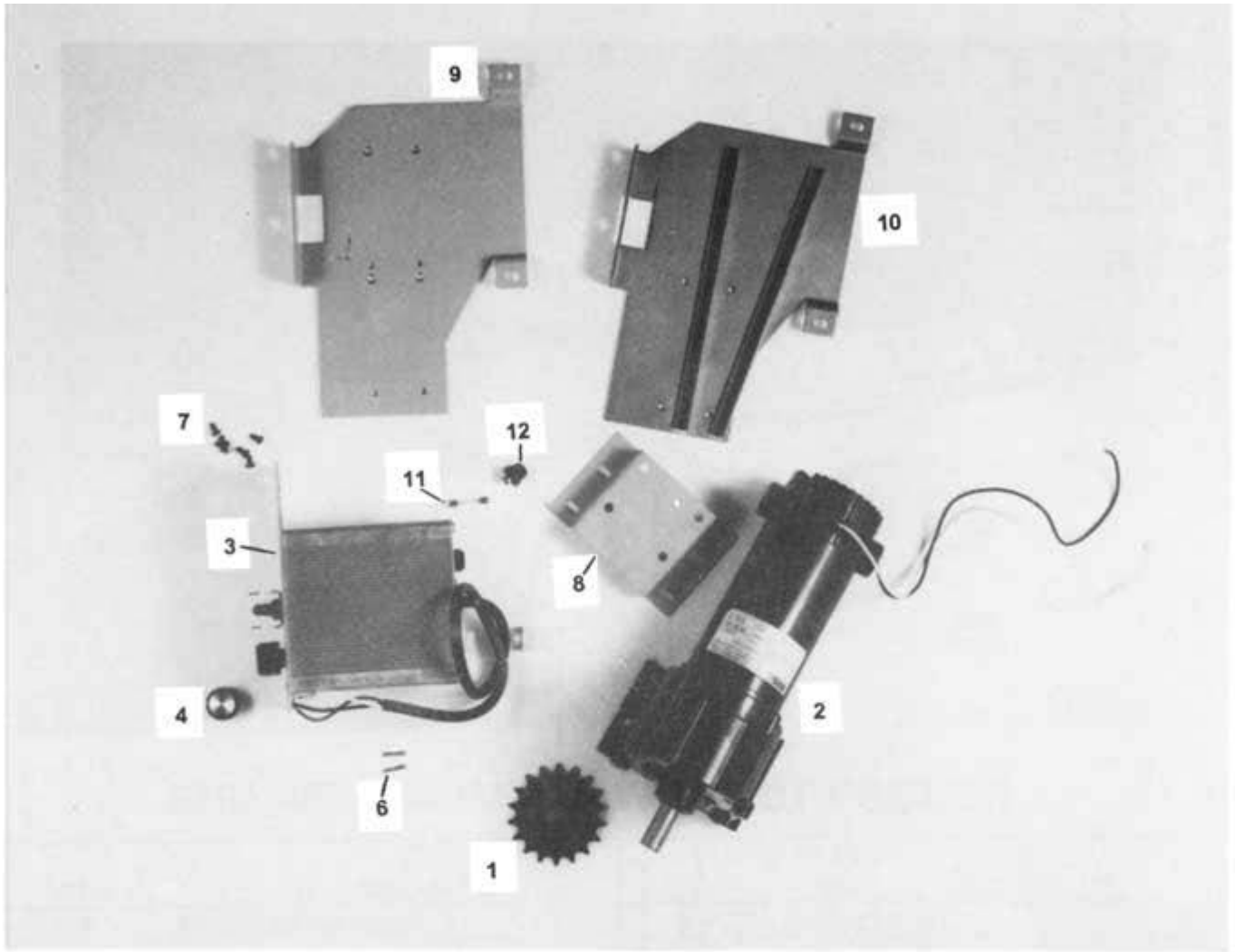

ELECTRONIC VARIABLE SPEED CONTROL

Models 875LR & 850LR

ITEM	DESCRIPTION	PART NUMBER	QUANTITY PER UNIT	MODELS
1	Motor Sprocket	762-1-EVM	1	850LR and 875LR
2	Electronic Motor	763-EVM	1	850LR and 875LR
3	Electronic Control Box	763-EVC	1	850LR and 875LR
4	Speed Control Knob	763-EVC-1	1	850LR and 875LR
5	Controller Plug (for motor/not shown)	763-EVC-2	1	850LR and 875LR
6	Controller Plug Pin (for motor leads)	763-EVC-3	2	850LR and 875LR
7	Controller Mounting Screw	763-EVC-4	6	850LR and 875LR
8	Motor Plate Bracket	763-EVM-2	1	850LR and 875LR
9	Motor Platform	763-EVM-1	1	875LR
10	Motor Platform	763-EAS	1	850LR
11	Fuse	763-EVC-8	1	850LR and 875LR
12	Fuse Cap	763-EVC-9	1	850LR and 875LR

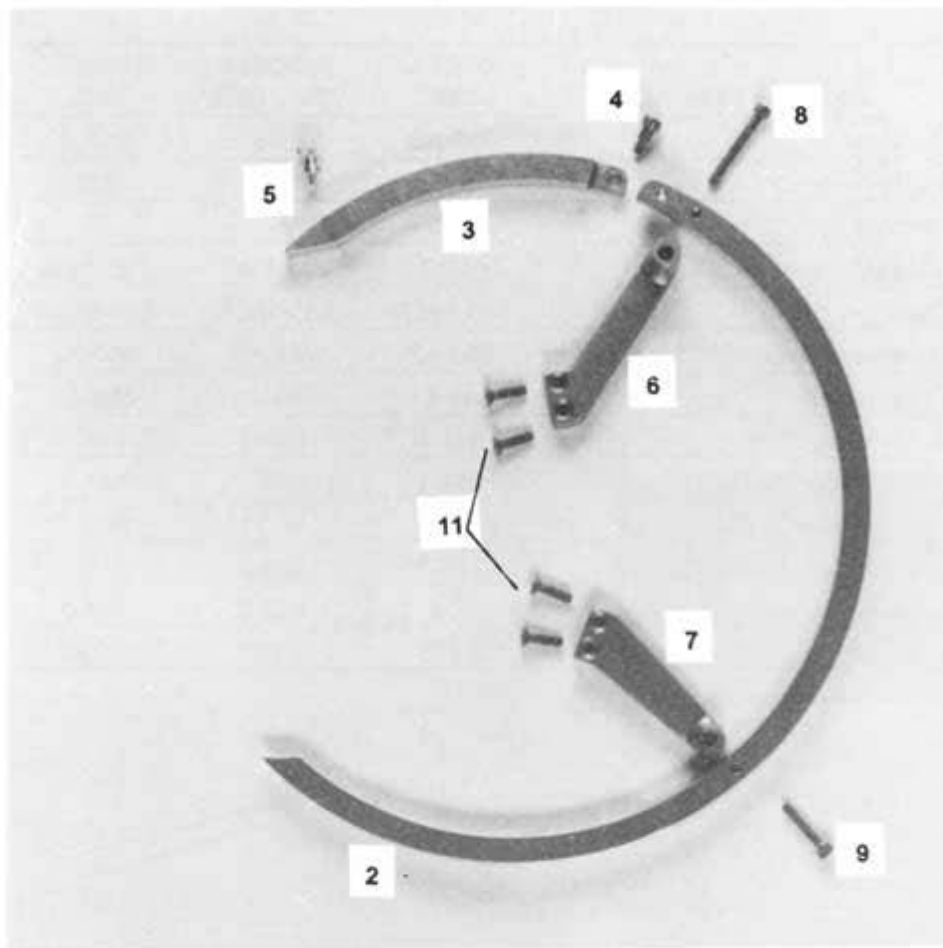

RING GUARD PARTS

All "LR" Models

ITEM	DESCRIPTION	PART NUMBER	QUANTITY PER UNIT
1	Rim Guard Assembly (#2,3,4 & 5)	942-AS	1
2	Lower Rim Guard	942-1	1
3	Upper Rim Guard	942-2	1
4	Rim Guard Hinge Screw	942-3	1
5	Upper Rim Guard Knob	821-4	1
6	Upper Rim Guard Arm	944-1	1
7	Lower Rim Guard Arm	944-2	1
8	Rim Guard Screw - Upper	944-1A	1
9	Rim Guard Screw - Lower	944-2A	1
10	Rim Guard Screw Washer (not shown)	925-26	2
11	Gear Housing Leg Screw	944-3	4

SWITCH PARTS

ITEM	DESCRIPTION	MODEL 500L	MODELS 725L, 825L	MODEL 775L	MODELS 875L, 850L
1	Wire Harness	933-AS	895	893-A	933-AS
3	Switch Box	878	878	878	878
4	Wire Harness	-	-	-	-
5	Switch Guard	785-1SG	785-1SG	785-1SG	785-1SG
6	Data Plate	885-1BLR	885-1BLR	885-1BLR	885-1BLR
8	Wire Harness Clamp	869-A2	869-A2	869-A2	869-A2
9	Splice Connector	869-A1	869-A1	869-A1	869-A1
11	Switch - 3 Phase Only	648-1	648-1	648-1	648-1
15	Switch Box Cover Screw	867-1	867-1	867-1	867-1
17	Wire Harness Clamp Screw	852-1	852-1	852-1	852-1
19	Switch Box Fibre	878-2	878-2	878-2	878-2
20	Switch Shank Insulating Bushing	875	850-3	850-3	850-3
21	Switch Shank Mounted - 1 Phase Only	0-785	0-785	0-785	0-785

WASTE BOX PARTS

ITEM	DESCRIPTION	SLICER PART NUMBERS
		ALL MODELS
1	Waste Box	758-P
2	Waste Box Pin	758-1

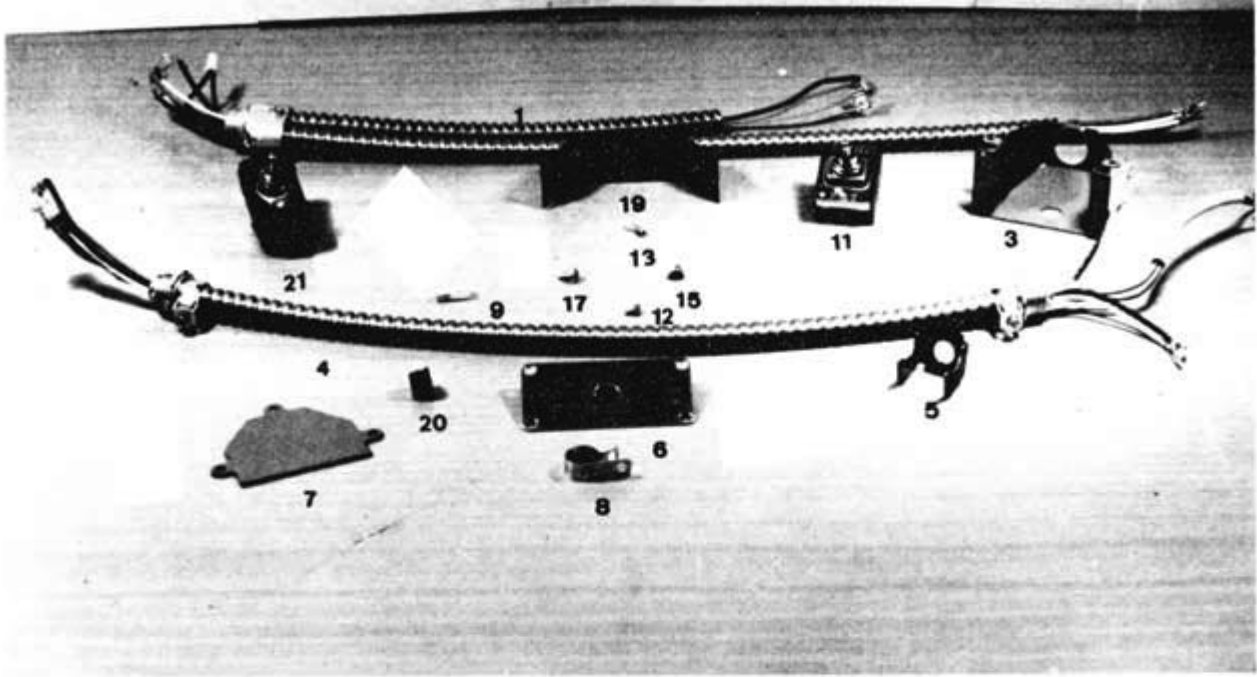

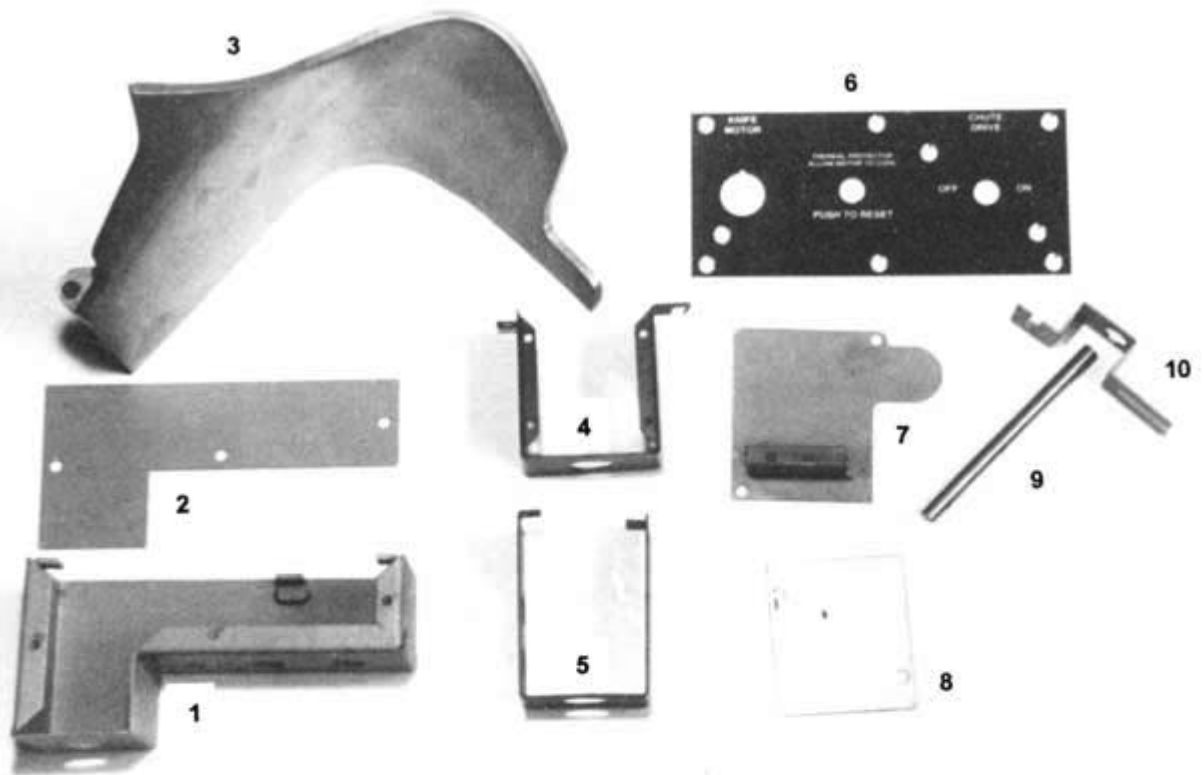

NO VOLTAGE RELEASE METAL PARTS

ITEM	DESCRIPTION	PART NUMBER	MODELS
1	Electrical Box	952-AS	725LR/825LR
2	Electrical Box Cover	952-3	725LR/825LR
3	Slice Deflector	861	ALL
4	Switch Box	952-4	500LR
5	Strain Relief Bracket	952-2	850LR/875LR
6	Switch Plate	952-7	725LR/825LR
6	Switch Plate	954	850LR/875LR
7	Relay Bracket	952-1	ALL
8	Switch Box Cover	952-5	500LR
9	Reset Button Rod	907-1F	725LR/825LR
10	Reset Button Rod Bracket	907-5NVR	725LR/825LR
11	Gear Motor Reset Assembly (includes 9 & 10)	907-NVR	725LR/825LR

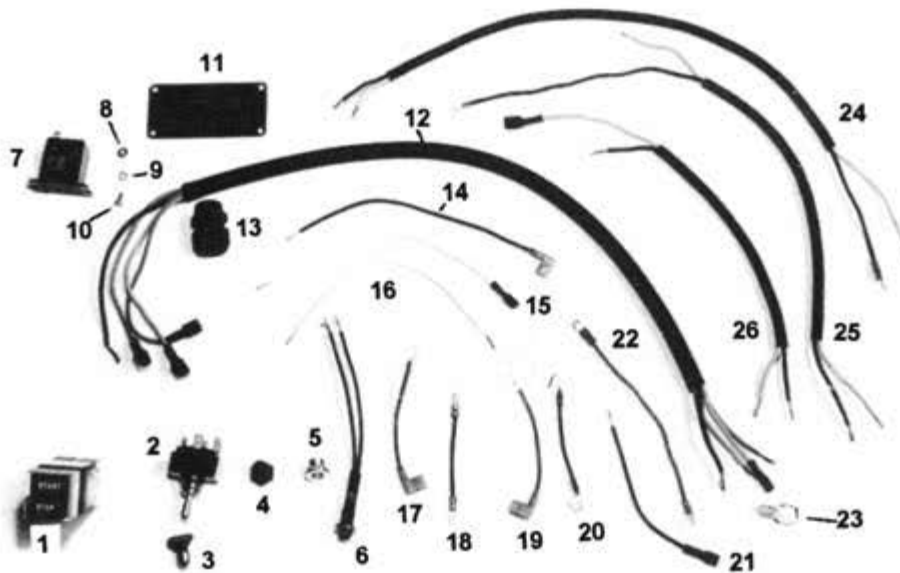

NO VOLTAGE RELEASE ELECTRICAL PARTS

ITEM	DESCRIPTION	PART NUMBER	MODELS
1	Main Switch (Automatic)	952-10	725LR/825LR/850LR/875LR
2	Main Switch (Manual)	952-8	500LR
3	Toggle Switch Boot	952-13	ALL
4	Reset Button Boot	952-14	725LR/825LR
5	Bushing, Reset Button	952-6	725LR/825LR
6	Indicator Light	952-11	ALL
7	Relay, Main Power	952-9	ALL
8	Hex Nut, 6-32	952-23	ALL
9	Lock Washer, #6	952-22	ALL
10	Screw, 6-32 x 3/8"	952-21	ALL
11	Data Plate	860-2BNVR	500LR
11	Data Plate	885-1BNVR	725LR/825LR/850LR/875LR
12	Main Harness	952-16	500LR
12	Main Harness	952-17	725LR/825LR/850LR/875LR
13	Fitting Cord Grip	952-12	ALL
14	Wire Assy. Blk. (Relay "B")	956-5	ALL
15	Wire Assy. Wht. (Micro Sw. Com.)	956-4	ALL
16	Lead Wire Wht. (Pwr. Cord to Mtr.)	956-8	ALL
17	Wire Assy. Blu. (Relay Term. "A")	956-7	ALL
18	Wire Assy. (Auto Sw. Jumper)	956-2	725LR/825LR/850LR/875LR
19	Wire Assy. Red (Relay Term)	956-6	ALL
20	Wire Assy. (Manual Sw. Jumper)	956-1	500LR
21	Wire Assy. Blk (Micro Sw. N.O.)	956-3	ALL
22	Wire Assy. Red (Chute Mtr. Sw.)	956-9	725LR/825LR
23	Wire Joint	952-15	ALL
24	Harness, Chute Motor	952-19	725LR/825LR
25	Harness, Pilot Light	952-18	725LR/825LR/850LR/875LR
26	Harness, Pilot Light	952-20	500LR

NOT FOR RESALE
FORM G-222 REV. 4/02
© GLOBE FOOD EQUIPMENT CO.

PRINTED IN U.S.A.