

Parts Catalog



C10

Slicing Machine

Model: C10

12/13/17N Rev. E

IMPORTANT!

TO EXPEDITE SHIPMENT OF PARTS, ALWAYS SPECIFY MODEL, REV,
PART NUMBER, AND SERIAL NUMBER OF UNIT.

GLOBE FOOD EQUIPMENT COMPANY

2215 East River Road
Dayton, Ohio 45439

Parts Department

Toll Free 1-800-745-6238 · Fax (937) 290-0585

E-Mail: info@globefoodequip.com

Website: www.globefoodequip.com

Not for resale

Table of Contents

Description	Page
C10 Base Components	4
C10 Chute Components	6
C10 Knife and Sharpener Components	8
C10 Electrical Components	10
C10 Wiring Diagram 115V 50_60Hz, 1PH	12

C10 Base Components

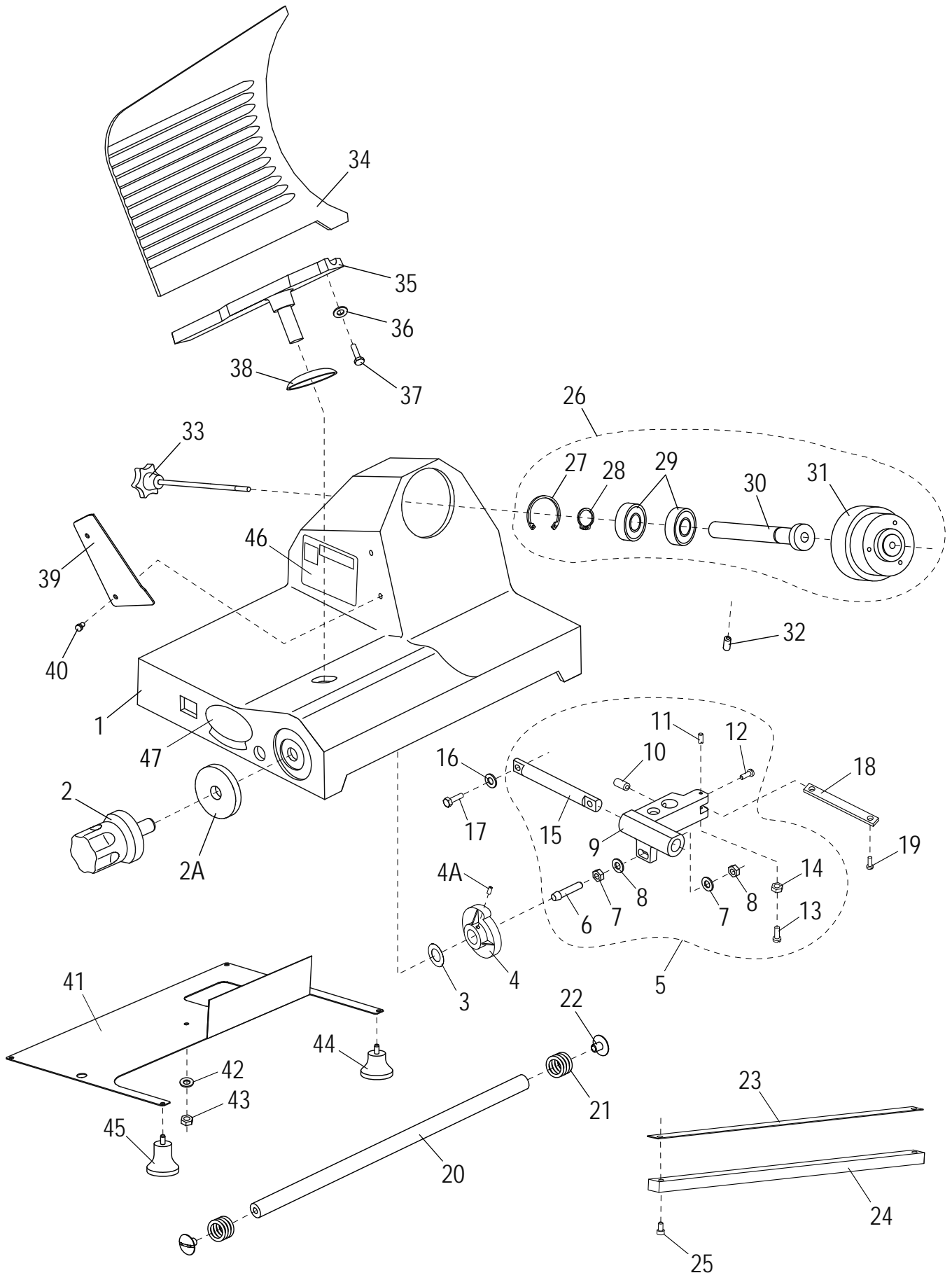



C10 Base Components

Item	Part Number	Description	Qty	Serial Number
1		Slicer Base	1	
2	M00205	Table Adjustment Knob	1	
2A	M00210	Table Adjustment Ferrule	1	
3	MCA32	Wavy Washer	1	
4A	H00181	Set Screw	2	
4	MCA33	Table Adjustment Cam	1	
5	MC002	Table Slide Assembly (Incl. items 6-15)	1	
6	MCA34	Cam Actuator Stud	1	
7	M035	Flat Washer	2	
8	M034	Hex Nut	2	
9		Table Slide	1	
10	H00186	Set Screw M8-1.25x10 Cup Pt. Hex Socket - BO	2	
11	H00182	Set Screw M5x10 Flat Pt Slotted - Zn	1	
12	H00189	Cheese Hd Screw M4-0.7x10 Slotted - Zn	1	
13	H00187	Cheese Hd Screw M5-0.8x16 Slotted - Zn	1	
14	H00028	Hex Nut M5 - Zn	1	
15	MCA36	Table Slide Rod	1	
16	M035	Flat Washer	2	
17	H00190	Hex Hd Screw M5x16 - Nickel	2	
18	MCA35	Table Slide Plate	1	
19	H00061	Hex Head Screw M5x10, Zinc	2	
20	MCA26	Carriage Slide Rod	1	
21	MCA27	Carriage Spring	2	
22	MCA25	Carriage Slide Rod Screw	2	
23	MCA31/1	Wear Strip	1	
24	MCA31	Square Slide Bar	1	
25	H00187	Cheese Hd Screw M5-0.8x16 Slotted - Zn	2	
26	MCA12	Knife Hub Assembly (Incl. items 27-31)	1	
27	H00053	Retaining Ring, Internal	1	
28	H00194	Retaining Ring, External	1	
29	MCA12/3	Bearing	2	
30		Knife Pulley Shaft	1	
31		Knife Pulley	1	
32	H00183	Set Screw M5x10 Cup Pt. Hex Socket - BO	1	
33	M00215	Knife Cover Release Knob	1	
34	M00221	Table	1	
35	M00239	Table Support	1	
36	M035	Flat Washer	2	
37	H00043	Hex Head Screw M6x25 - Zn	2	
38	M00218	Base Hole Cover	1	
39	MCA22/1	Deflector	1	
40	MCC23	Thumb Screw	2	
41	MCA64USA	Bottom Cover	1	
42	H00063	Flat Washer, M5, Zinc	1	
43	H00028	Hex Nut M5 - Zn	1	
44	MCA24/1	Back Foot	2	
45	M00220	Front Foot	2	
46	M91022	Label, Warning	1	
47	M91020	Label, Chefmate	1	



C10 Chute Components

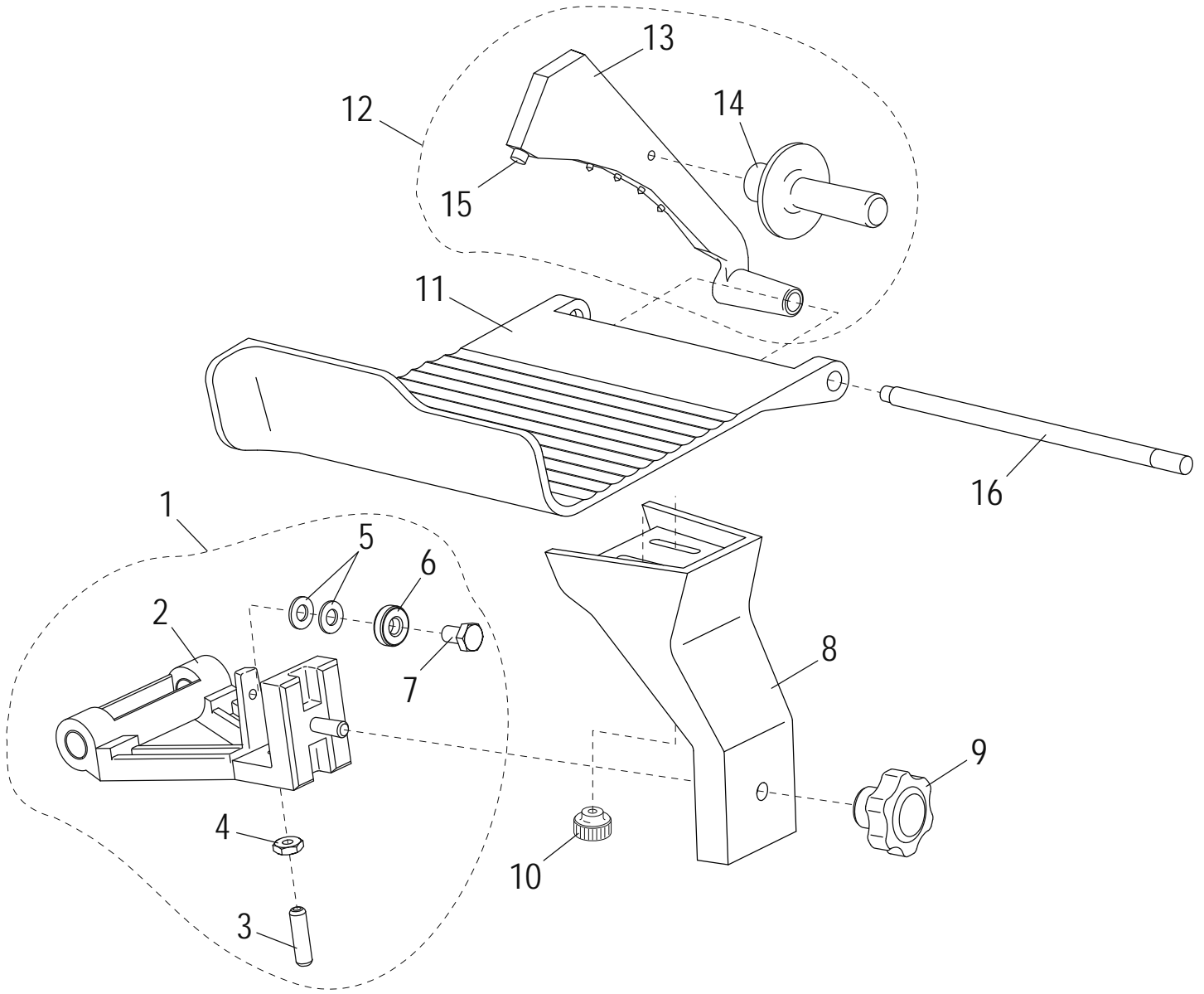



C10 Chute Components

Item	Part Number	Description	Qty	Serial Number
1	MC006	Chute Slide Assembly (Incl. items 2-7)	1	
2		Chute Slide	1	
3	M053	Brass Stud	1	
4	H00192	Hex Nut M8-1.25,13mm Width,4 mm Height-Zn	1	
5	H00191	Flat Washer M8, 8.4 IDx16 ODx1.4-1.8mm thick DIN 125 - Zn	2	
6	MCA29	Bearing	1	
7	H00116	Hex Head Screw M6-1.0x20 - Zn	1	
8	M00673	Chute Support	1	
9	M00253	Chute Support Knob	1	
10	M00284	Chute Release Knob	1	
11	M00276	Chute	1	
12	MC008	End Weight Assembly (Incl. items 13-15)	1	
13		End Weight	1	
14	M00257	End Weight Handle	1	
15	M108	End Weight Bumper	1	
16	M00258	End Weight Rod	1	

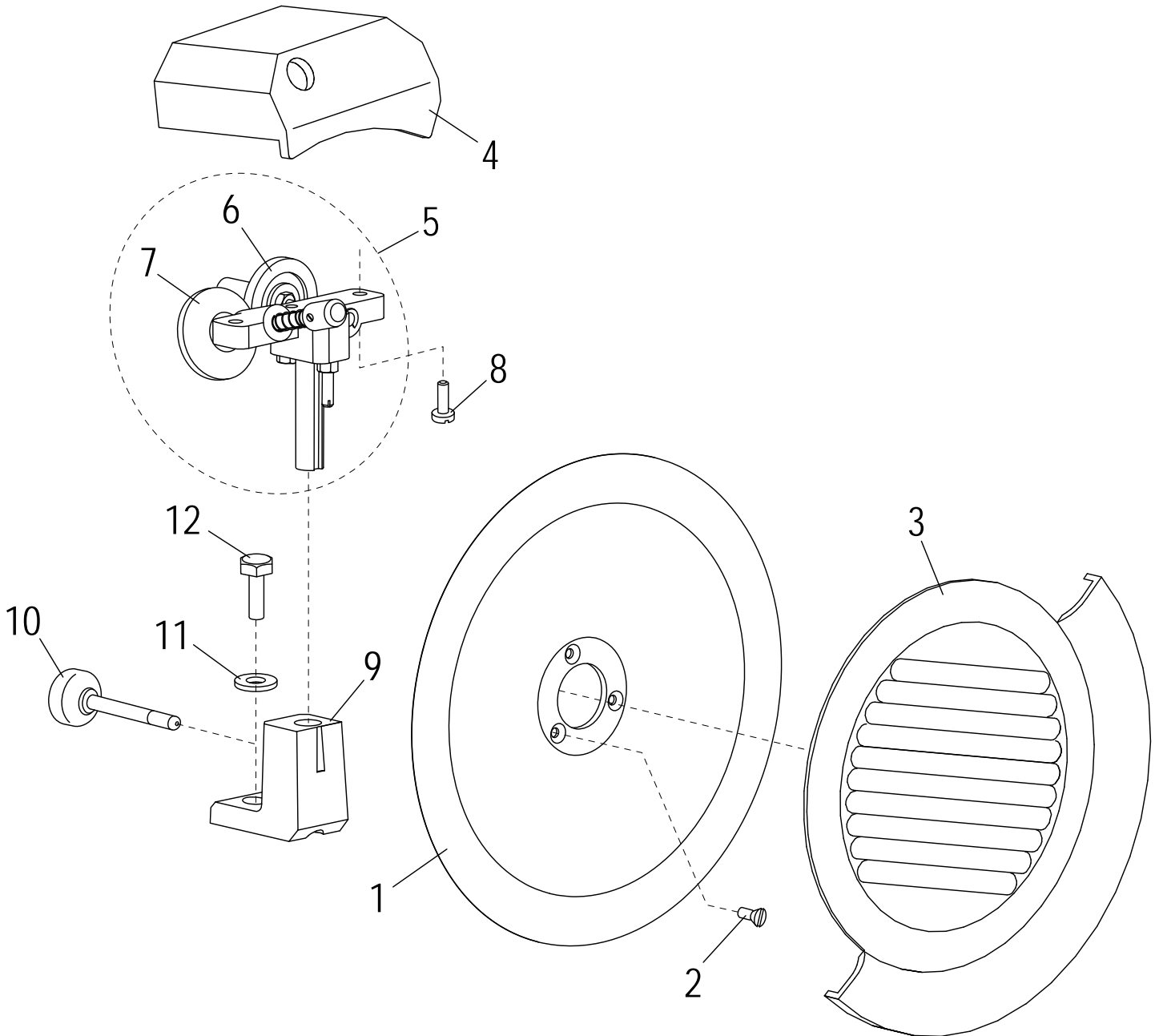



C10 Knife and Sharpener Components

Item	Part Number	Description	Qty	Serial Number
1	MCB13	Knife	1	
2	H00200	Flat Hd Screw M5x10 Slotted - SS	3	
3	MCB4USA	Knife Cover	1	
4	MCB11	Sharpener Cover	1	
5	MCB16	Knife Sharpener Assembly (Incls. items 6-7)	1	
6	M092	Deburring Stone	1	
7	M091	Sharpening Stone	1	
8	H00187	Cheese Hd Screw M5-0.8x16 Slotted - Zn	2	
9	MCB10	Sharpener Support	1	
10	M096	Release Knob, Sharpener	1	
11	H00191	Flat Washer M8, 8.4 IDx16 ODx1.4-1.8mm thick DIN 125 - Zn	1	
12	H00117	Hex Head Screw M8x20 - Zn	1	

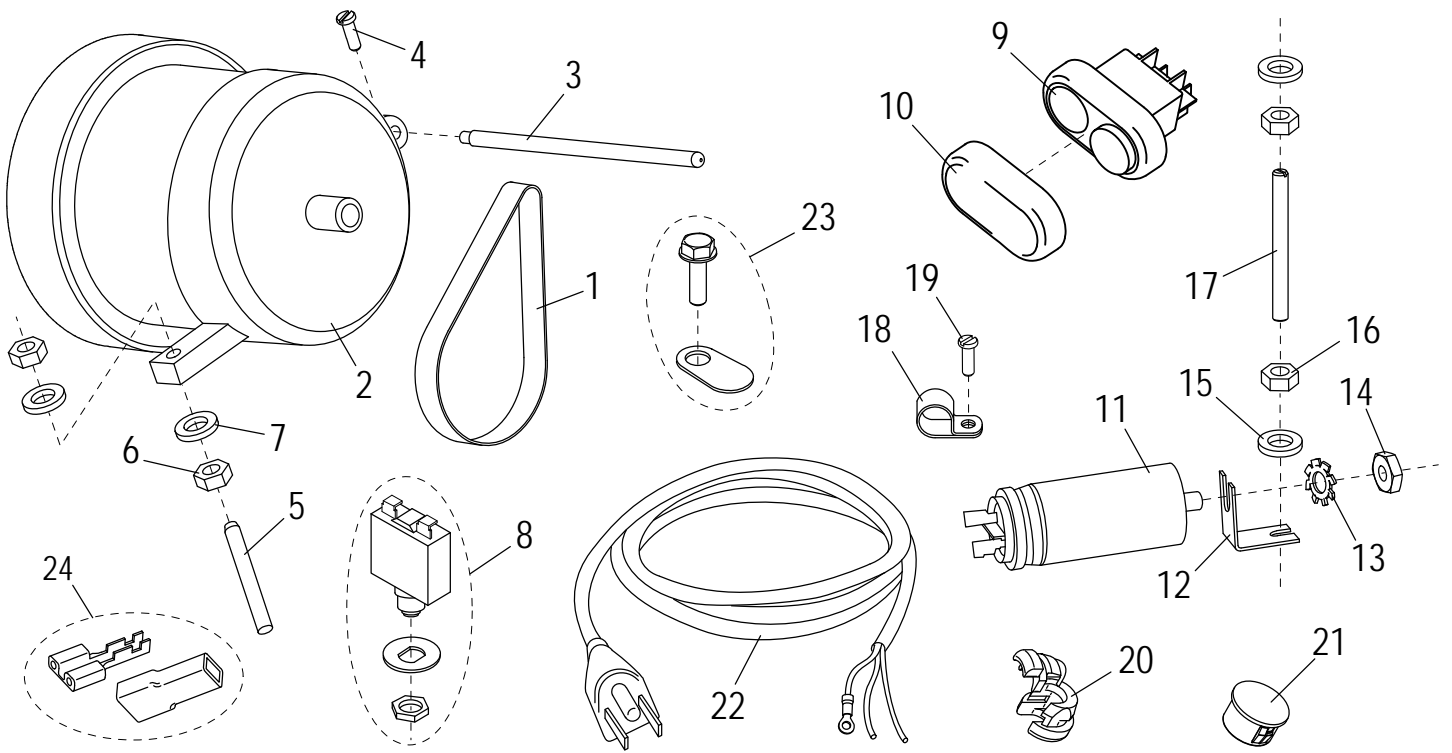



C10 Electrical Components

Item	Part Number	Description	Qty	Serial Number
1	MCB51	Drive Belt	1	
2	MCL43/2	Knife Motor	1	
3	M031	Post, Motor Pivot	1	
4	H00189	Cheese Hd Screw M4-0.7x10 Slotted - Zn	1	
5	M033	Set Screw	1	
6	M034	Hex Nut	2	
7	M035	Flat Washer	2	
8	M038	Motor Reset Switch	1	
9	MCR68	Power Switch	1	
10	MCR59	Power Switch Cover	1	
11	M039	Capacitor, 16 µf	1	
12		Capacitor Mounting Bracket	1	
13	H00335	Lock M8 Washer	1	
14	H00192	Hex Nut M8-1.25,13mm Width,4 mm Height-Zn	1	
15	H00063	Flat Washer, M5, Zinc	2	
16	H00028	Hex Nut M5 - Zn	2	
17	M00369	Cover Spacer Stud	1	
18	M037	Cable Clamp	1	
19	H00061	Hex Head Screw M5x10, Zinc	1	
20	M111	Strain Relief	1	
21	MCC80	Hole Plug	1	
22	MB65/4F	Power Cord & Plug	1	
23	M00334	Ground Screw/Marking Tab Set	1	
24	M00233	Female Terminal/Insulator Set	8	



C10 Wiring Diagram 115V 50_60Hz, 1PH

