

# Parts Catalog

**Commercial Pro**



**Model CPF32**

## **ELECTRIC FRYERS**

**MODELS:**

**CPF10, CPF16 & CPF32**

08-26-2011

**IMPORTANT!**

TO EXPEDITE SHIPMENT OF PARTS, ALWAYS SPECIFY MODEL, REV,  
PART NUMBER, AND SERIAL NUMBER OF SLICER.

### **GLOBE FOOD EQUIPMENT COMPANY**

2215 East River Road

Dayton, Ohio 45439

#### **Parts Department**

Toll Free 1-800-745-6238 · Fax (937) 290-0585

E-Mail: [globeinfo@globeslicers.com](mailto:globeinfo@globeslicers.com)

Website: [www.globeslicers.com](http://www.globeslicers.com)

Not for resale



## TABLE OF CONTENTS

	<u>PAGE</u>
<u>CPF10 FRYER</u>	<u>1</u>
<u>CPF16 FRYER</u>	<u>2</u>
<u>CPF32 FRYER</u>	<u>3 - 4</u>
<u>WIRING DIAGRAM</u>	<u>5</u>

# CPF10 COMPONENTS

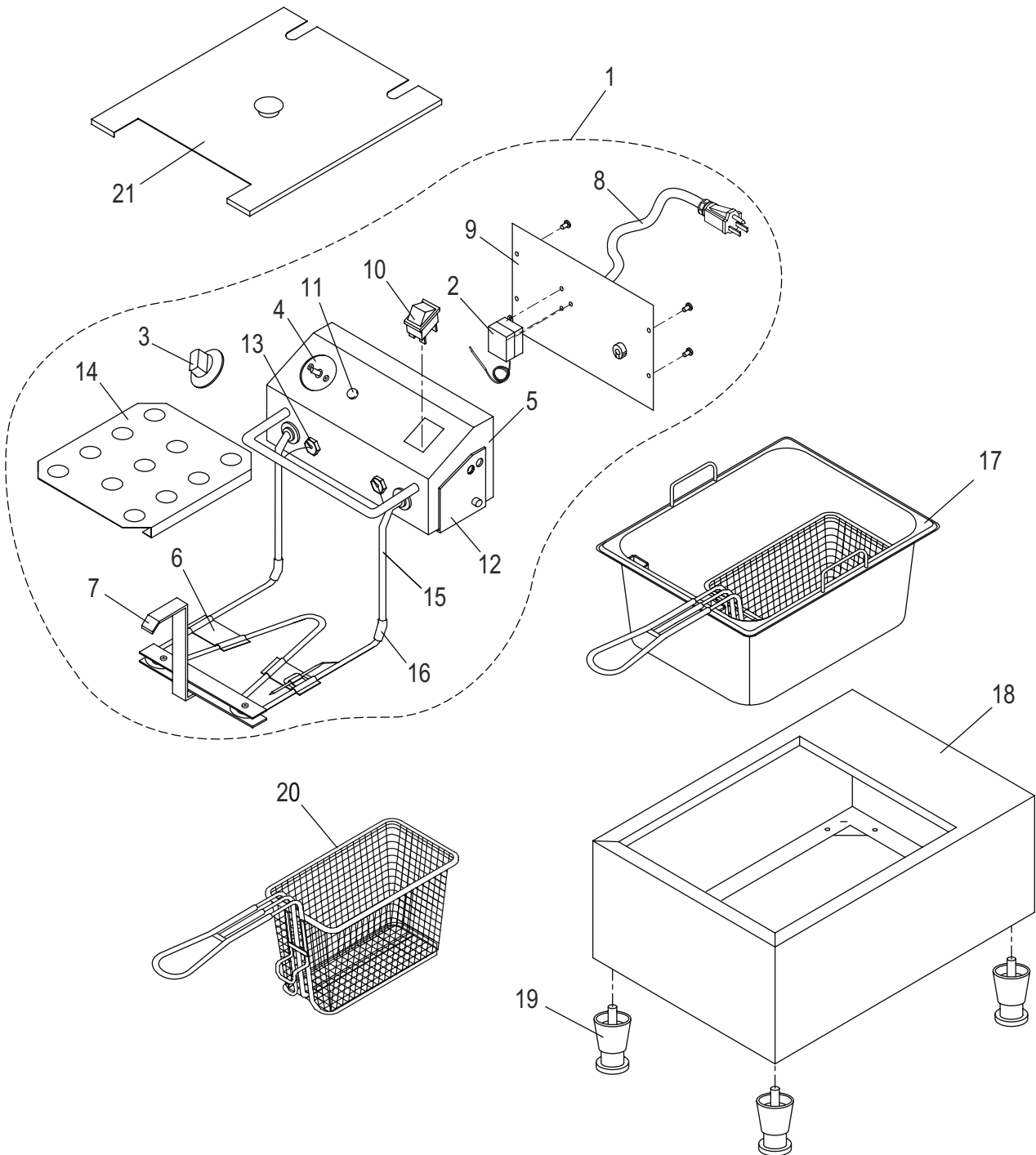

Item	Description	Part No.	Qty	Item	Description	Part No.	Qty
1	Control Box Assembly	U06051470132	1	12	Control Assy Support Brkt	-	2
		*U06051471090		13	Stuffing Nut	U01021005017	2
2	Thermal Cut Out	U03051220004	1	14	Element Cover	U01051025555	1
3	Thermostat Knob	U02101155013	1	15	Heating Element	U03061225044	1
4	Thermostat	U03051220008	1	16	Tube Bend Clamp	U01051025128	2
5	Control Enclosure	-	1	17	Pan	U01121063013	2
6	Tube Clamp	U01051025402	2			*U06051471080	
7	Element Hook	U06051470011	1	18	Fryer Cabinet	-	1
8	Cord & Plug (120V)	U03021205012	1	19	Foot	U01021005002	4
9	Back Cover Plate	-	1	20	Basket	BASKET10	2
10	On/Off Switch	U03041215027	1			*SMBASKET10	
11	Indicator Light (120V)	U03091240005	1	21	Cover -Optional extra	FRYCOVER10	1

\*Used after serial number CPF10100001052-1010.

# CPF16 COMPONENTS

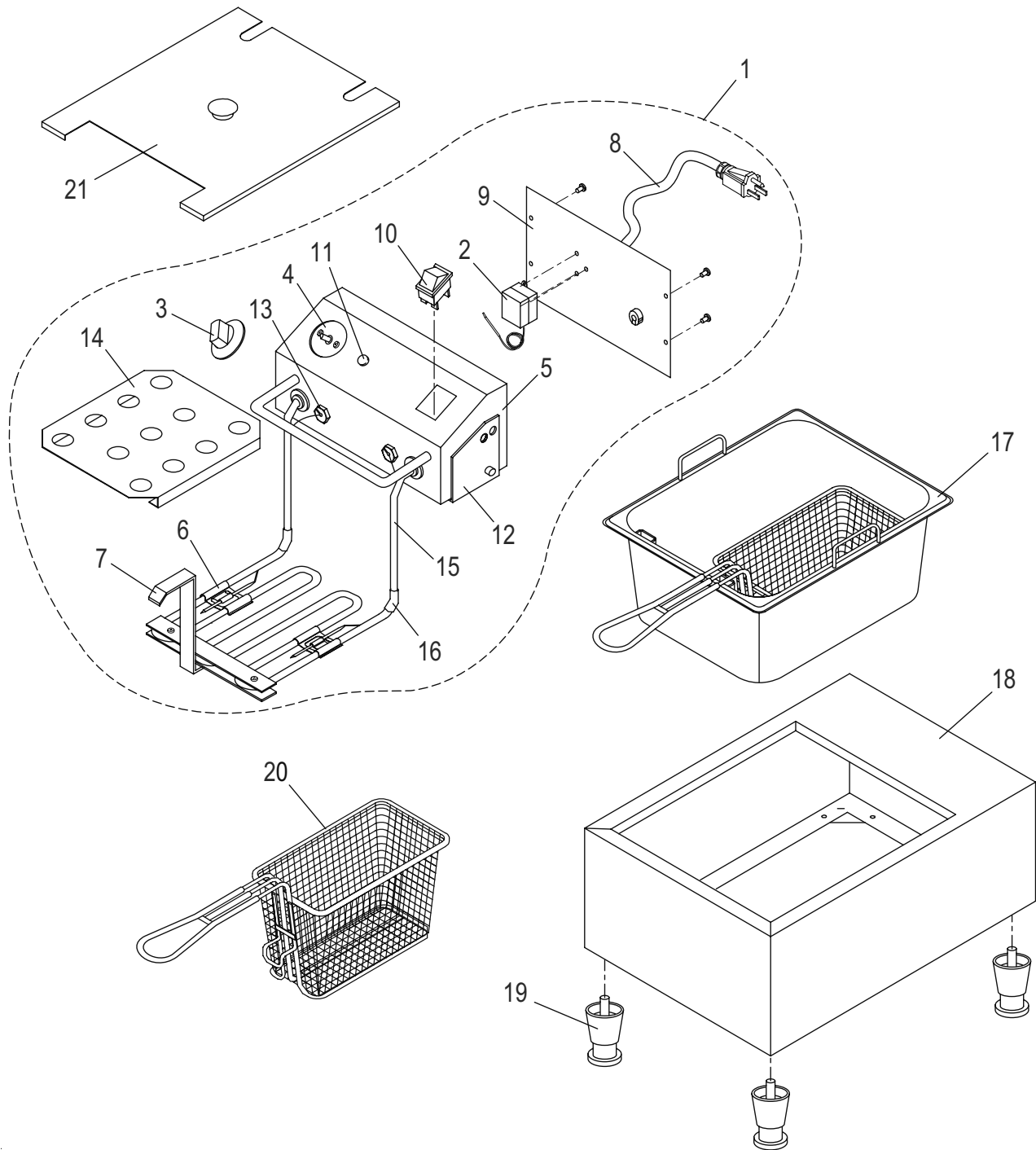

Item	Description	Part No.	Qty	Item	Description	Part No.	Qty
1	Control Box Assembly	U06051470151	1	12	Control Assy Support Brkt	-	2
		*U06051471097		13	Stuffing Nut	U01021005017	2
2	Thermal Cut Out	U03051220004	1	14	Element Cover	U01051025555	1
3	Thermostat Knob	U02101155013	1	15	Heating Element	U03061225047	1
4	Thermostat	U03051220008	1	16	Tube Bend Clamp	U01051025128	2
5	Control Enclosure	-	1	17	Pan	U01121063016	1
6	Tube Clamp	U01051025117	2			*U06051471081	
7	Element Hook	U06051470010	1	18	Fryer Cabinet	-	1
8	Cord & Plug (240V)	U03021205013	1	19	Foot	U01021005002	4
9	Back Cover Plate	-	1	20	Basket	BASKETTWIN1632	2
10	On/Off Switch	U03041215027	1			*TMBASKET1632	
11	Indicator Light (240V)	U03091240006	1	21	Cover -*Optional extra	FRYCOVER16	1

\*Used after serial number CPF160000756-775.

# CPF32 COMPONENTS

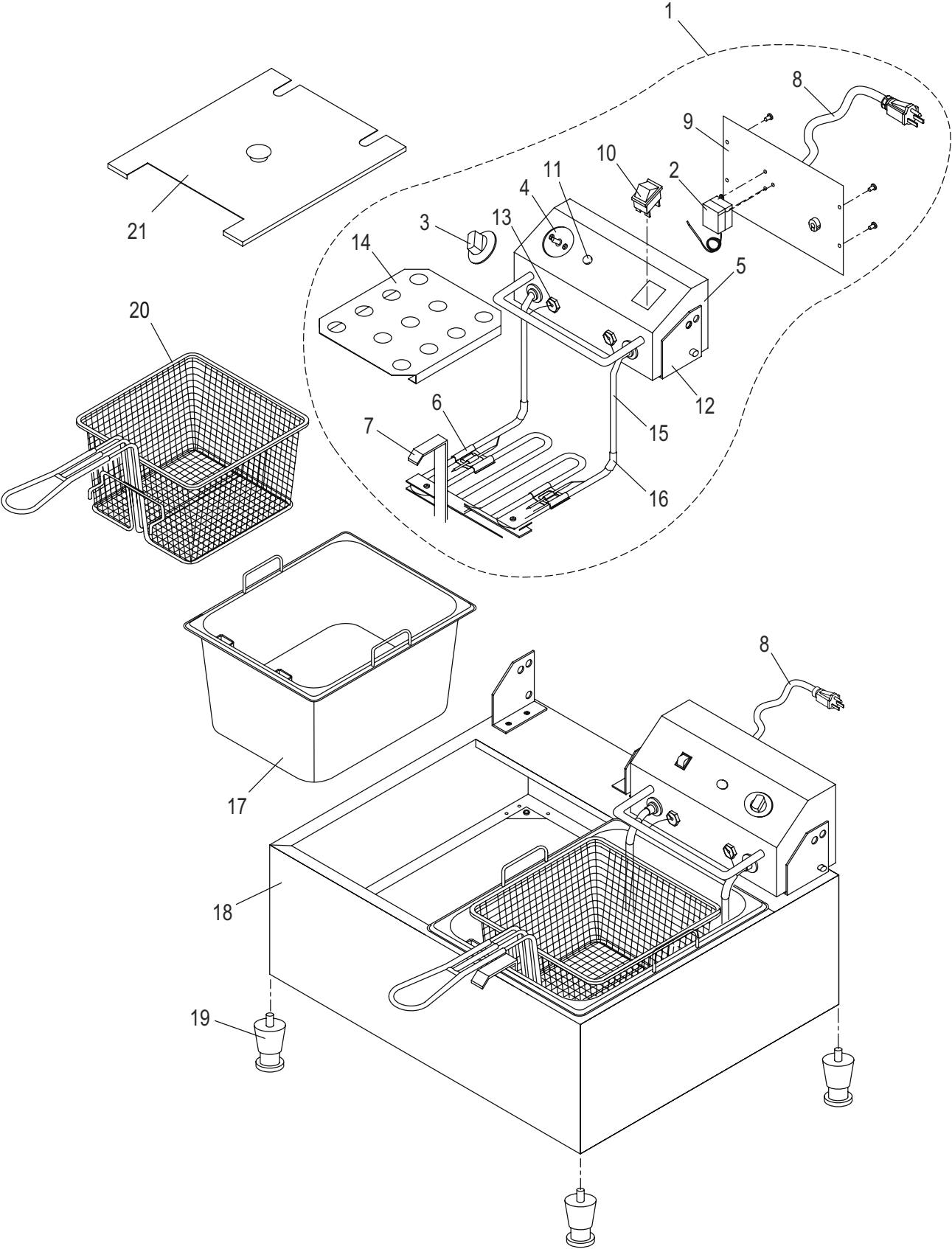

# CPF32 PARTS LIST

Item	Description	Part No.	Qty
1	Control Box Assembly, Left	U06051470149	1
		*U06051471096	
	Control Box Assembly, Right	U06051470151	1
		*U06051471097	
2	Thermal Cut Out	U03051220004	2
3	Thermostat Knob	U02101155013	2
4	Thermostat	U03051220008	2
5	Control Enclosure	-	2
6	Tube Clamp	U01051025117	4
7	Element Hook	U06051470010	2
8	Cord & Plug (240V)	U03021205013	2
9	Back Cover Plate	-	2
10	On/Off Switch	U03041215027	2
11	Indicator Light (240V)	U03091240006	2
12	Control Assy Support Bracket	-	4
13	Stuffing Nut	U01021005017	4
14	Element Cover	U01051025555	2
15	Heating Element	U03061225047	2
16	Tube Bend Clamp	U01051025128	4
17	Pan	U01121063016	2
		*U06051471081	
18	Fryer Cabinet	-	1
19	Foot	U01021005002	4
20	Basket	BASKETLARGE1632	4
		*LGBASKET1632	
21	Cover -Optional extra	FRYCOVER1032	2

\* Used after serial number CPF32000805-850.

# WIRING DIAGRAM, CPF10/CPF16/CPF32 FRYERS

