



Model #: \_\_\_\_\_

Serial #: \_\_\_\_\_



## Instruction Manual for Compact Manual Slicer Models E220, E250 & E300

### For Service on Your Slicer:

Call the Service Department at:

Phone: 800-347-5423

Or: 866-260-0522

and ask for contact information for your local service company.

### - IMPORTANT SAFETY NOTICE -

This manual contains important safety instructions that must be strictly followed when using this equipment.

WARRANTY REGISTRATION  
SCAN THE QR CODE WITH YOUR MOBILE DEVICE OR GO TO  
[WWW.GLOBEFOODEQUIP.COM](http://WWW.GLOBEFOODEQUIP.COM)  
TO FILL OUT AND SUBMIT YOUR WARRANTY REGISTRATION.

[www.globefoodequip.com/support/warranty-registration-form](http://www.globefoodequip.com/support/warranty-registration-form)

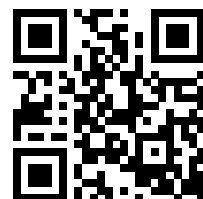



# Index

ATTENTION OWNERS AND OPERATORS.....	4
KEY COMPONENTS OF THE SLICER .....	5
SLICER SAFETY TIPS.....	6
INSTALLATION .....	7-8
OPERATING INSTRUCTIONS.....	9
CLEANING .....	10-11
CLEANING AND REASSEMBLY.....	12
REASSEMBLY AND INSPECTION .....	13
KNIFE SHARPENING .....	14-15
SIMPLE MAINTENANCE AND REPAIR.....	16-17
TROUBLESHOOTING GUIDE.....	18
LIMITED SLICER WARRANTY.....	20



**2153 DRYDEN RD.  
DAYTON, OH 45439  
PHONE: 937-299-5493  
TOLL FREE: 866-260-0522  
FAX: 937-299-4147**

# Attention Owners and Operators

Globe's equipment is designed to provide years of safe and productive processing of food products as long as the equipment is used in accordance with the instructions in this manual and is properly maintained. Importantly, unless the operator is adequately trained and supervised, there is a possibility of serious injury. Owners of this equipment bear the responsibility to make certain that this equipment is used properly and safely. Strictly follow all of the instructions contained in this manual and the requirements of local, state and/or federal law.

Owners should not permit anyone to touch this equipment unless they are over 18 years old, are adequately trained and supervised, and have read and understand this manual. Owners should also ensure that no customers, visitors or other unauthorized personnel come in contact with this equipment. Please remember that Globe cannot anticipate every circumstance or environment in which its equipment will be operated. It is the responsibility of the owner and the operator to remain alert to any hazards posed by the function of this equipment, particularly the sharp knife blade and all moving parts. If you are ever uncertain about a particular task or the proper method of operating this equipment, ask your supervisor.

To prevent illness caused by the spread of food-borne pathogens, it is important to properly clean and sanitize the entire slicer as any surface of the slicer can become contaminated. It is the responsibility of the slicer owner/operator to follow all guidelines, instructions and laws as established by your local and state health departments and the manufacturers of chemical sanitizers.

When cleaning your slicer, pay particular attention to cracks, broken seams and any area that may collect food debris. If your slicer, or any of its parts, is damaged or broken, it may become more difficult to properly clean and sanitize the unit. If your slicer is damaged or needs repair, contact an experienced service individual immediately to ensure the slicer can be properly sanitized. If you have any questions, please contact Globe at 937-299-5493.

This manual offers information to supplement your procedures to improve the sanitization of your machine and contains a Safety Tips section listing a number of precautions to follow to help promote safe use of this equipment. Throughout the manual you will see additional warnings to help alert you to potential hazards.

**Warnings affecting your personal safety are indicated by:**



or



**Warnings related to possible damage to the equipment are indicated by:**



A wall chart with safety instructions is included with this equipment. This wall chart should be posted near the slicer within easy view of the operator. You should make certain that this manual is available for easy reference by any operator. Globe has put several warning labels in the English language on the slicer. Spanish labels are also available and can replace the English labels at the owner's discretion. If the warning labels or this manual are misplaced, damaged or illegible, or if you require additional copies, please contact your nearest representative or Globe directly for replacement of these items at no charge.

Please remember that this manual, the wall chart nor the warning labels replace the need to be alert, to properly train and supervise operators, and to use common sense when using this equipment.

# Key Components of the Slicer

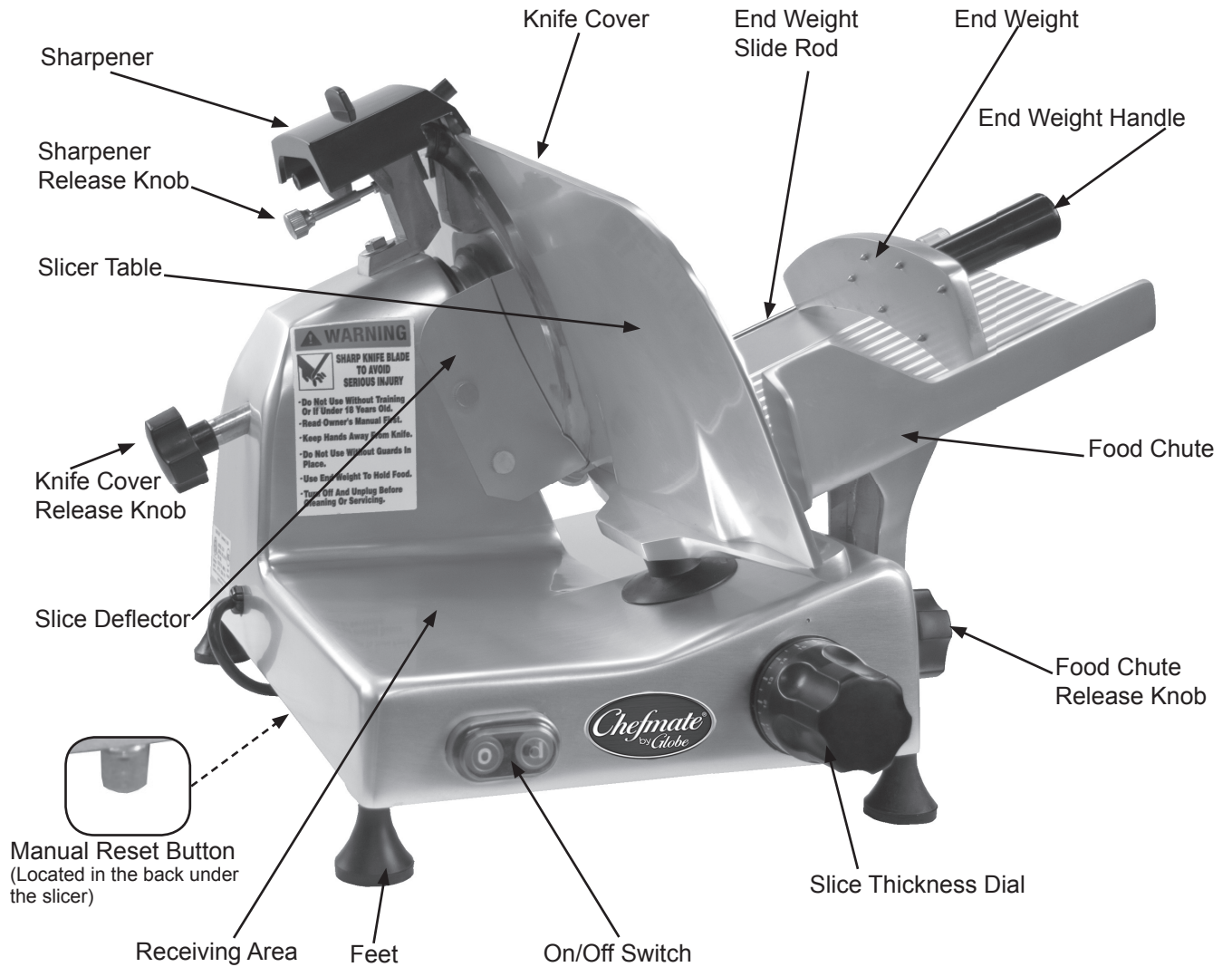

## Slicer Safety Tips



# SHARP KNIFE BLADE

TO AVOID SERIOUS PERSONAL INJURY:

- **NEVER** touch this slicer without training and authorization from your supervisor or if you are under 18 years old. Read this instruction manual first.
- **ONLY** install the slicer on a level, nonskid surface that is nonflammable and is located in a clean, well-lit work area away from children and visitors.
- **ALWAYS** ground slicer utilizing proper power source.
- **NEVER TOUCH KNIFE.** Keep hands and arms away from all moving parts.
- **NEVER OPERATE** slicer without knife cover and sharpener securely installed.
- **BE ALERT** when the slicer is on and in motion.
- **NEVER HOLD THE FOOD PRODUCT WHILE SLICING.** Hold only the end weight handle to slice.
- **DO NOT CATCH SLICES WITH YOUR HAND.** Let slices drop onto the receiving area.
- **ALWAYS** turn slicer off and turn the slice thickness dial clockwise past zero “0” until it stops after each use.
- **BEFORE CLEANING, SHARPENING, SERVICING OR REMOVING ANY PARTS,** always turn slicer off, turn the slice thickness dial clockwise past zero (0) until it stops, remove food chute and unplug power cord.
- **ALWAYS properly clean and sanitize your slicer.** To prevent illness or death caused by the spread of food-borne pathogens, it is important to properly clean and sanitize the entire slicer as any surface of the slicer can become contaminated. It is the responsibility of the slicer owner/operator to follow all guidelines, instructions and laws as established by your local and state health departments and the manufacturers of chemical sanitizers.
- **USE ONLY PROPERLY INSTALLED SLICER ACCESSORIES (Only if Applicable)**

# Installation

## UNPACKING

1. Unpack the slicer immediately after receipt. If the machine is found to be damaged, save the packaging material and contact the carrier within fifteen (15) days of delivery. Immediately contact your source of the equipment. **You have no recourse for damage after fifteen (15) days.**
2. You should receive with the slicer: four rubber feet, oil, warranty card and an instruction manual. Contact your local supplier or Globe Service if you did not receive all of these materials.



### **TO AVOID SERIOUS PERSONAL INJURY, PROPERLY INSTALL SLICER IN ADEQUATE WORK AREA**

- **ALWAYS** install equipment in a work area with adequate light and space.
- **ONLY** operate the slicer on a solid, level, nonskid surface that is nonflammable.
- **NEVER** bypass, alter or modify this equipment in any way from its original condition. Doing so may create hazards and will void warranty.
- **NEVER** operate slicer without the knife cover and the sharpener securely installed.
- **NEVER** operate slicer without the warning label attached.

## INSTALLATION

1. Read this manual thoroughly before installation and operation. **DO NOT** proceed with installation and operation if you have any questions or do not understand everything in the manual. Contact your local representative.
2. Remove the slicer from the corrugated box.
3. Make sure the rubber feet are firmly tightened.



**NEVER USE SLICER WITHOUT RUBBER FEET INSTALLED.**

4. Select a location for the slicer that has a level, solid, nonskid surface that is nonflammable and is in a well-lit work area that is away from children and visitors.



**USE AT LEAST TWO PEOPLE TO LIFT THE SLICER UP TO THE OPERATING LOCATION. NEVER ATTEMPT TO LIFT THE SLICER ALONE.**

# Installation

**THIS MACHINE IS PROVIDED WITH A THREE-PRONG GROUNDING PLUG. THE OUTLET TO WHICH THIS PLUG IS CONNECTED MUST BE PROPERLY GROUNDED. IF THE RECEPTACLE IS NOT THE PROPER GROUNDING TYPE, CONTACT AN ELECTRICIAN. DO NOT, UNDER ANY CIRCUMSTANCES, CUT OR REMOVE THE THIRD GROUND PRONG FROM THE POWER CORD OR USE ANY ADAPTER PLUG (Figure 8-1 and Figure 8-2).**

5. Inspect the slicer to make sure all parts have been provided.
6. Make sure the knife cover and knife sharpener are in place.
7. Make sure the warning label is properly positioned and legible and the instruction manual is available near the slicer.
8. Complete the warranty registration online at [www.globefoodequip.com/support/warranty-registration-form](http://www.globefoodequip.com/support/warranty-registration-form).
9.  **Be sure to properly clean and sanitize your slicer before use.** Follow the procedures outlined in the cleaning section of this manual before using the slicer.
10. Contact your local representative if you have any questions or problems with the installation or operation of this slicer.

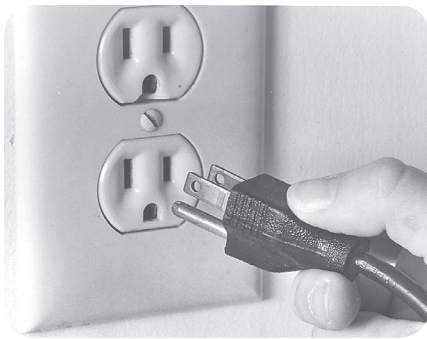

Figure 8-1 Correct



Figure 8-2 **INCORRECT**



# Operating Instructions

**WARNING**



## SHARP KNIFE BLADE

### TO AVOID SERIOUS PERSONAL INJURY:

- NEVER touch this slicer without training and authorization from your supervisor or if you are under 18 years old. Read this instruction manual first.
- NEVER TOUCH KNIFE. Keep hands and arms away from all moving parts.
- NEVER OPERATE slicer without knife cover securely installed.
- BE ALERT when the slicer is on and in motion.
- NEVER HOLD THE FOOD PRODUCT WHILE SLICING. Hold only the end weight handle to slice.
- ONLY USE THE END WEIGHT, NOT YOUR HAND, to hold food products when slicing. Never put your hand on, or around, food chute when slicer is on.
- DO NOT CATCH SLICES WITH YOUR HAND. Let slices drop onto the receiving area.
- AFTER EACH USE, ALWAYS turn slicer off and turn the slice thickness dial clockwise past zero "0" until it stops.
- BEFORE CLEANING, SHARPENING, SERVICING OR REMOVING ANY PARTS, always turn slicer off, turn the slice thickness dial clockwise past zero (0) until it stops, remove food chute and unplug power cord.

### SLICER OPERATION

1. Make sure all knobs are tightened before using the slicer.
2. With the slicer turned off, pull the food chute completely towards you and place the food product onto the food chute. Slice only boneless, unfrozen product with the slicer. Use the end weight to hold the food product in place.
3. Rotate the slice thickness dial counterclockwise to the desired slice thickness.  
REMEMBER: After slicing is complete, always turn the slice thickness dial clockwise until it stops to close the slicer table.
4. Turn the slicer on.



**DO NOT hold the food product with your hand. Never put your hand on, or around, the food chute when the slicer is on. The food chute handle is the only part of the slicer you should touch while slicing.**

5. Use the end weight handle to manually push the food chute back and forth. The food chute handle is the only part of the slicer you should touch while slicing. Do not catch slices with your hand. Let slices drop onto the receiving area.



**If a product needs to be adjusted during slicing, ALWAYS pull the food chute all the way towards you, turn the slicer off and close the slicer table before adjusting the product and the end weight.**

6. After the last slice stroke, pull the food chute all the way towards you. Turn the slicer off and turn the slice thickness dial clockwise until it stops to close the slicer table.
7. Now you can load and unload food product from the food chute.

# Cleaning

## WARNING



## SHARP KNIFE BLADE

**TO AVOID SERIOUS PERSONAL INJURY TO THE SLICER OPERATOR AND YOUR CUSTOMERS:**

- **BEFORE CLEANING, SHARPENING, SERVICING OR REMOVING ANY PARTS**, always turn slicer off, turn the slice thickness dial clockwise until it stops and unplug the power cord.
- **NEVER** attempt to clean slicer with the knife running.
- **NEVER** attempt to remove the knife or knife ring guard from the slicer. They must remain on the slicer for proper operation, sharpening, and cleaning.

## WARNING

To prevent illness or death caused by the spread of food-borne pathogens, it is important to properly clean and sanitize the entire slicer as any surface of the slicer can become contaminated. It is the responsibility of the slicer owner/operator to follow all guidelines, instructions and laws as established by your local and state health departments and the manufacturers of chemical sanitizers.

 **Once your slicer makes contact with food product, the entire slicer, including removable parts, must be thoroughly cleaned and sanitized. This process is to be repeated at least every 4 hours using these procedures and information and also in compliance with additional laws from your state and local health departments.**

 **As with all food contact surfaces, it is extremely important to properly sanitize the entire slicer and to **closely follow the instructions on your quaternary sanitizer container to make sure proper sanitation is achieved to kill potentially harmful bacteria.****

**NOTE:** It may be desirable to wear non-cutting safety gloves during the cleaning operation.

**IMPORTANT:** If a chemical sanitizer other than chlorine, iodine or quaternary ammonium is used, it shall be applied in accordance with the EPA-registered label use instructions. Excessive amounts of sanitizer and use of products not formulated for stainless steel or aluminum may VOID your warranty.

Sanitizer concentration shall comply with section 4-501.114, Manual and Mechanical Warewashing Equipment, Chemical Sanitization - Temperature, pH, Concentration and Hardness of the FDA Food Code.

**For more information on proper kitchen and equipment sanitation, visit [www.servsafe.com](http://www.servsafe.com) provided by the National Restaurant Association (NRA).**

## CAUTION

- **DO NOT** hose down, pressure wash, or pour water on the slicer.
- **DO NOT** put components in dishwasher.
- **NEVER** use a scrubber pad, steel wool, or abrasive material to clean the slicer.
- **ALWAYS** turn slicer off and unplug power cord **BEFORE** cleaning.
- **It is extremely important to follow the instructions on the sanitizer container to make sure proper sanitation is achieved. Allow the parts to air dry before placing them back onto the slicer!**

# Cleaning

## **DISASSEMBLY & CLEANING**

1. Turn the slicer off, turn the slice thickness dial clockwise until it stops so the table covers the knife's edge and unplug the power cord.

Remove all of the slicer's removable parts. Clean, scrub, and sanitize all parts.

2. Begin by removing the end weight slide rod by unscrewing it from the slicer's food chute (Fig. 11-1).
3. Remove the food chute by rotating the food chute release knob counterclockwise until it comes completely off. Pull the food chute off the support arm (Fig. 11-2).
4. Place the food chute upside-down on a flat surface so that the support arm is standing in the upward position.

Unscrew the hook and anchor, releasing the support arm to pivot freely on the support arm screw pin (Fig 11-3).

Unscrew the support arm using the screw grip. Turn the screw pin counterclockwise until the screw pin releases from the support arm.

5. The slice deflector can be removed by unscrewing the screw knobs (Fig. 11-4).



**BE ALERT. The next steps will expose the knife.**

6. Remove the knife sharpener. Loosen the knife sharpener screw until the knife sharpener moves freely and can be removed.
7. Remove the knife cover by rotating the knife cover release knob (Fig. 11-5) counterclockwise until it comes completely out. Using the rim of the knife cover, carefully lift the knife cover straight up and away from the blade. Use extreme caution when removing the knife cover, paying close attention to where your fingers are.
8. Place all removable parts in a three compartment sink with warm water and a mild detergent solution; soak, clean, and thoroughly scrub all surfaces using a solution of mild detergent and warm water. Removable parts: food chute (all parts), end weight, knife cover and slice deflector.

Rinse removed parts with fresh, clean water. Following the instructions on your quaternary sanitizer label, soak the food chute, knife cover and slice deflector in a proper solution of quaternary sanitizer for a minimum of two minutes. Allow these parts to air dry.

**An important step to kill bacteria is to allow the parts to air dry before reinstalling!**



Fig. 11-1



Fig. 11-2

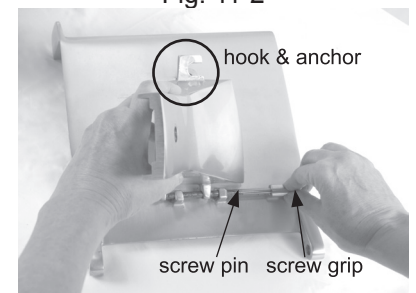

Fig. 11-3



Fig. 11-4



Fig. 11-5

# Cleaning and Reassembly

9. The knife must also be cleaned and sanitized. **Carefully** wash and rinse the top and bottom of the knife by wiping from the **center of the knife outward** (Fig. 12-1).
10. Spray both sides of the knife, slicer table and the entire slicer base with a non-bleach, non-chlorine sanitizer following the instructions on your quaternary sanitizer container to ensure proper sanitation is achieved. Allow the slicer parts to air dry.



Fig 12-1

**An important step to kill bacteria is to allow the parts to air dry before reassembly!**

**DO NOT allow moisture to get into knife hub.**

After cleaning and sanitizing the knife, the rest of the entire slicer must be fully cleaned, sanitized and left to air dry before reattaching slicer parts and before use.

## **REASSEMBLE & REINSTALL REMOVABLE PARTS**

After cleaning, sanitizing, and allowing the parts to air dry, they must be reinstalled.

Make sure the knife position is closed.

**⚠ BE ALERT! Use extreme caution when removing the knife cover, paying close attention to where your fingers are.**

1. Reinstall the knife cover. Carefully place the knife cover on by aligning the center screw over the center of the knife and seal. With one hand applying pressure in the center of the knife cover holding it in place, and one hand on the knife cover release knob (Fig 12-2), turn the knife cover release knob clockwise to tighten the knife cover into place. Make sure the grooves that are in the knife cover are horizontally lined with the grooves on the slicer table.
2. Reinstall the knife sharpener. Set the knife sharpener correctly in place and tighten the knife sharpener screw until the knife sharpener is securely in place. Sharpener **MUST** be in place and secure before slicing.
3. Reinstall the slice deflector. Place the slice deflector and screw knobs in place. Tighten both screw knobs into place (Fig 12-3).
4. Reassemble and reinstall the food chute.



Fig. 12-2



Fig. 12-3

Place the food chute upside-down on a flat surface.

Reconnect the support arm to the food chute. Line up the support arm on the food chute and thread the screw pin through all four braces. With the arm pivoted, tighten the screw pin using the screw grip until it is finger tight and securely in place.

Slide the support arm hook securely under the anchor knob and tighten it into place (Fig 12-4).

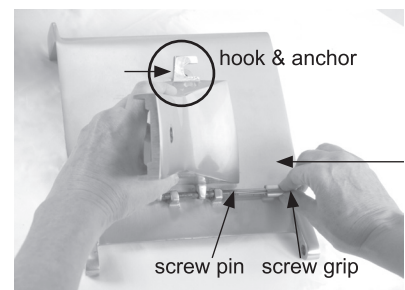

Fig. 12-4

# Reassembly and Inspection

5. Place the cleaned and sanitized food chute back onto the chute arm (Fig 13-1). Securely tighten the food chute release knob to prevent any “play” between the food chute and the chute arm.
6. Reattach the end weight slide rod by threading it back through the food chute and end weight; then screw it back into the bottom of the food chute (Fig. 13-2).
7. Plug in power cord.

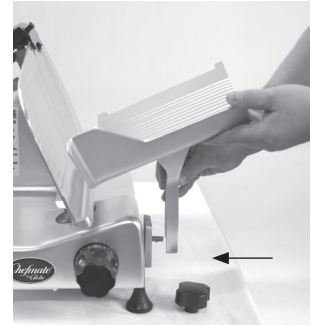

Fig. 13-1



Fig. 13-2

## INSPECTION

INSPECT THE SLICER FOR DAMAGED OR BROKEN PARTS INCLUDING GASKETS & SEALS. A thorough visual inspection should be made of the entire slicer and its parts. Globe urges the owner/operator to inspect all components often and for an authorized service agent to inspect the entire slicer at least every 6 months, including all parts that are detachable for cleaning and sanitizing. This inspection should include looking for damaged parts, broken seals or gaskets, and areas that may be more difficult to clean and sanitize.

**IF A SEAL OR GASKET IS FOUND TO NOT PROPERLY SEAL, IS DAMAGED, OR IS MISSING, THE SLICER MUST BE REMOVED FROM SERVICE UNTIL IT IS REPAIRED BY AN AUTHORIZED SERVICER.**

## AREAS TO INSPECT



1. Seal around the slicer thickness dial

2. Seal around the boot cover of the ON/OFF switch

3. Seal on the receiving table

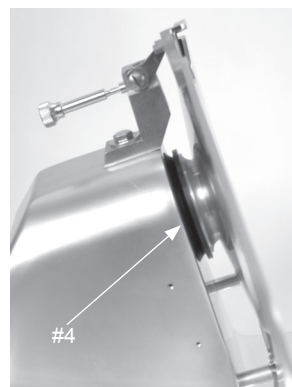

4. Seal in between the hub and the knife



5. Seal in center of knife

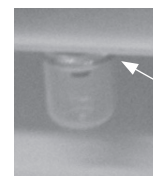

6. Seal on boot of reset button

# Knife Sharpening



## SHARP KNIFE BLADE

### TO AVOID SERIOUS PERSONAL INJURY:

- **NEVER** touch rotating knife.
- **ALWAYS** keep hands clear of all moving parts.
- **ALWAYS** turn the slicer off, turn the slice thickness dial clockwise until it stops, and remove the food chute before sharpening.
- **NEVER** sharpen slicer unless all guards are installed.

### WHEN AND HOW OFTEN TO SHARPEN THE KNIFE

1. Indication of a dull knife is excess waste (or “tail”) on the unsliced portion remaining in the food chute.
2. The knife needs to be sharpened periodically to provide consistent slices and maximum food product yield. Sharpening the knife lightly every few days is more effective than heavy sharpening at less frequent intervals.

### PREPARING TO SHARPEN

To prevent illness or death caused by the spread of food-borne pathogens, it is important to properly clean and sanitize the entire slicer as any surface of the slicer can become contaminated. It is the responsibility of the slicer owner/operator to follow all guidelines, instructions and laws as established by your local and state health departments and the manufacturers of chemical sanitizers.

#### **WARNING**



**Before sharpening, it is extremely important to clean and sanitize the slicer completely according to the cleaning instructions presented in this manual. The slicer must be cleaned and sanitized again after sharpening.**

1. Turn the slicer off and turn the slice thickness dial clockwise until it stops so the slicer table covers the knife's edge.
2. Remove food chute from the slicer.
3. Clean and dry both sides of the knife before sharpening. Refer to Cleaning section.

NOTE: The knife cover must be attached and secure during sharpening.

4. Loosen the sharpener release knob by turning it counterclockwise several times (Fig. 14-1).



**BE ALERT. The next step will expose the knife.**

5. Lift the sharpener cover up (Fig. 14-1), rotate it clockwise and lower it into position with the knife fitting between the two stones (Fig. 14-2).
6. Tighten the sharpener release knob (Fig. 14-1) to secure the sharpener.

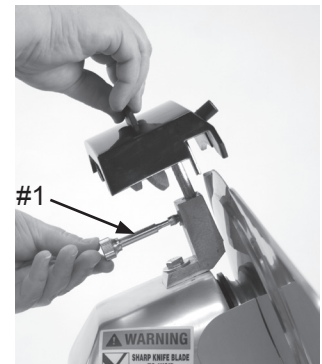

Figure 14-1



Figure 14-2

# Knife Sharpening

## SHARPENING THE KNIFE - Regular Procedure

1. Start the slicer.
2. Push the grinding stone button #2 (Fig. 15-1) and the honing stone button #3 at the same time so both stones make contact with the knife. Maintain pressure on the buttons for 5-10 seconds.

**TURN SLICER OFF before inspecting.**

## SHARPENING THE KNIFE - Extended Procedure

**NOTE: Use the extended procedure if the regular sharpening procedure does not produce satisfactory results.**

1. Start the slicer.
2. Push the grinding stone button #2 (Fig. 15-1) so the stone sharpens the back side of the knife. Maintain pressure on the button for 30 seconds.
3. Push the grinding stone button #2 (Fig. 15-1) and the honing stone button #3 at the same time so both stones make contact with the knife. Maintain pressure on the buttons for 5 seconds.

**TURN SLICER OFF before inspecting.**

## AFTER SHARPENING

1. Turn the slicer off and unplug the power cord.
2. Loosen the sharpener release knob.
3. Rotate the sharpener and place it back in its stored position.
4. Tighten the sharpener release knob.



**Slicer must be cleaned and sanitized again after sharpening. Refer to Cleaning section.**

5. Reinstall the food chute and plug the power cord in.



**IMPORTANT: The sharpener must be in place and secure to the top of the slicer before the slicer can be used.**



Figure 15-1

# Simple Maintenance and Repair

**WARNING**



## SHARP KNIFE BLADE

### TO AVOID SERIOUS PERSONAL INJURY:

- **ALWAYS** turn off slicer and unplug slicer before servicing.
- **NEVER** touch this slicer without training and authorization from your supervisor.
- **ALWAYS** keep hands clear of rotating knife and moving parts.
- **DO NOT** tamper with, bypass or remove any safety devices, guards or switches.
- **AFTER EACH USE, ALWAYS** turn off slicer and turn slice thickness dial completely clockwise past zero until it stops.

### LUBRICATION

Various slicer parts need to be lubricated periodically using oil. This oil is a light, tasteless, odorless mineral oil that will not contaminate or impart odors or taste to sliced food products.

**CAUTION**

**DO NOT USE VEGETABLE OIL TO LUBRICATE SLICER.  
VEGETABLE OIL WILL DAMAGE THE SLICER!**

### Food Chute Slide Rod

It is necessary to lubricate the food chute slide rod with oil if the food chute becomes difficult to push.

1. Close the slicer table, unplug the slicer and remove the food chute.
2. Tilt the slicer so that it is resting on its back with the slice thickness dial towards the ceiling.
3. Put several drops of oil on the slide rod (Fig. 16-1) towards the top of the rod.
4. Tilt the slicer back to its normal position.
5. Push the food chute arm back and forth several times to distribute the oil onto the slide rod.
6. Reinstall the food chute.
7. Plug the slicer in.

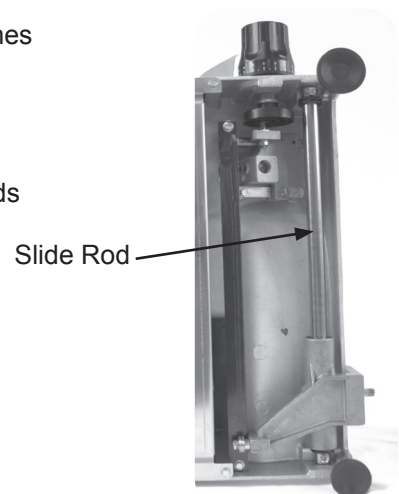

Figure 16-1



# Simple Maintenance and Repair

## **CAUTION**

**DO NOT USE VEGETABLE OIL TO LUBRICATE SLICER.  
VEGETABLE OIL WILL DAMAGE THE SLICER!**

### **Sharpener Shafts**

**It is necessary to lubricate the sharpener shafts with oil every week.**

1. Loosen the sharpener release knob and pull the sharpener up to remove it (Fig. 17-1).
2. Put several drops of oil on the shaft behind each sharpening stone (Fig 17-2).
3. Push both sharpener buttons a couple of times to distribute the oil onto the shafts.
4. Put several drops of oil on the main shaft (Fig. 17-1), place the sharpener back into position and tighten the sharpener release knob.
5. Wipe off any excess oil that drips onto the slicer.

**NOTE:** The sharpener and stones can be cleaned with warm water and a brush. Allow to air dry. **If the sharpener or stones are cleaned, it is very important that all sharpener shafts are lubricated with oil afterwards!**

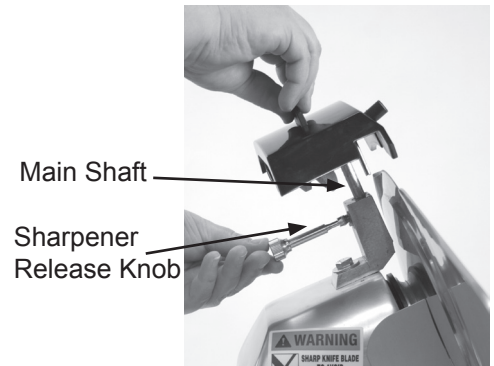

Figure 17-1

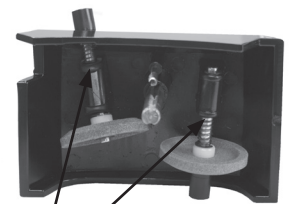

Figure 17-2  
Shafts

### **End Weight Slide Rod**

The end weight slide rod should be lubricated ever week with a few drops of oil once per week or more frequently should excessive drag be felt.

1. Apply a few drops of oil to the slide rod (Fig. 17-3).
2. Slide the end weight up and down to distribute the oil.



Figure 17-3

**We recommend that an authorized service company perform all adjustments and major maintenance.**

**By adequately maintaining your slicer,  
it will provide years of dependable service.**

# Troubleshooting Guide

PROBLEM	CAUSE	SOLUTION
Slicer will not start.	Slicer not plugged in.	Plug in slicer.
	Switch off.	Turn switch on.
Ragged cuts and/or poor yield.	Dull knife.	Sharpen knife-make sure knife and stones are clean.
	Chipped knife.	Sharpen or have new knife installed.
	Knife-slicer table gap too wide.	Call for service to adjust slicer table.
	Knife too small.	Have a new knife installed.
Metal rubbing knife.	Knife cover.	Tighten knife cover release knob.
	Food chute.	Tighten or adjust food chute knob.
	End weight.	Have defective end weight replaced.
	Slicer table.	Call for service to adjust slicer table.
Hard to push food chute.	No lubrication.	Lubricate slide rods thoroughly with oil. <b>DO NOT use vegetable oil!</b>
Hard to sharpen.	Stones dirty, wet or clogged with grease.	Clean stones with warm water and a brush. Allow stones to air dry. Lubricate shafts with oil afterward.
	Knife dirty.	Clean top and bottom of knife.
	Worn stones.	Have stones replaced.
	Stones not properly aligned.	Have sharpener adjusted.

If problem persists and the above solution does not remedy the issue, please call our Service Department at 866-260-0522.

**Notes:**

# Limited Warranty

Globe Food Equipment Company (“GFE”) warrants to the original purchaser of new equipment that said equipment, when installed in accordance with our instructions within North America and subjected to normal use, is free from defects in material or workmanship for a period of one year parts (excludes wear items) and one year labor warranty from original installation date or factory shipment date (not to exceed 18 months) whichever occurs first.

THIS WARRANTY IS IN LIEU OF ALL OTHER WARRANTIES, WHETHER EXPRESSED OR IMPLIED. GFE EXPRESSLY DISCLAIMS ANY IMPLIED WARRANTY OF MERCHANTABILITY OR EXPRESSED OR IMPLIED WARRANTY OF FITNESS FOR A PARTICULAR PURPOSE.

GFE’S OBLIGATION AND LIABILITY UNDER THIS WARRANTY IS EXPRESSLY LIMITED TO REPAIRING AND REPLACING EQUIPMENT WHICH PROVES TO BE DEFECTIVE IN MATERIAL OR WORKMANSHIP WITHIN THE APPLICABLE WARRANTY PERIOD. All repairs pursuant to this Warranty will be performed by an Authorized Designated GFE Service Location during normal working hours. IN NO EVENT SHALL GFE BE LIABLE FOR INCIDENTAL OR CONSEQUENTIAL DAMAGES TO BUYER OR ANY THIRD PARTY, INCLUDING, WITHOUT LIMITATION, LOSS OF PROPERTY, PERSONAL INJURY, LOSS OF BUSINESS OR PROFITS OR OTHER ECONOMIC LOSSES, OR STATUTORY OR EXEMPLARY DAMAGES, WHETHER IN NEGLIGENCE, WARRANTY, STRICT LIABILITY, OR OTHERWISE.

This warranty is given only to the first purchaser from a retail dealer. No warranty is given to subsequent transferees.

This warranty does not cover product failures caused by: failure to maintain, neglect, abuse, damage due to excess water, fire, normal wear, improper set up and use. Periodic maintenance, including lubrication and sharpening, are not covered.

This warranty is not in force until such time as a properly completed and signed installation/warranty registration or an online registration form has been received by GFE within 30 days from the date of installation. Register online at [www.globefoodequip.com/support/warranty-registration](http://www.globefoodequip.com/support/warranty-registration).

THE FOREGOING WARRANTY PROVISIONS ARE A COMPLETE AND EXCLUSIVE STATEMENT BETWEEN THE BUYER AND SELLER. GFE NEITHER ASSUMES NOR AUTHORIZES ANY PERSONS TO ASSUME FOR IT ANY OTHER OBLIGATION OR LIABILITY IN CONNECTION WITH SAID EQUIPMENT.

Example of items not covered under warranty, but not limited to just these items:

1. Acts of God, fire, water damage, burglary, accident, theft.
2. Freight damage.
3. Improper installation or alteration of equipment.
4. Use of generic or after market parts.
5. Repairs made by anyone other than a GFE designated servicer.
6. Lubrication.
7. Expendable wear parts, knife, stones, rubber boots, blown fuses, lamps.
8. Cleaning of equipment.
9. Misuse or abuse.

WARRANTY REGISTRATION  
SCAN THE QR CODE WITH YOUR MOBILE DEVICE OR GO TO  
[WWW.GLOBEFOODEQUIP.COM](http://WWW.GLOBEFOODEQUIP.COM)  
TO FILL OUT AND SUBMIT YOUR WARRANTY REGISTRATION.

[www.globefoodequip.com/support/warranty-registration](http://www.globefoodequip.com/support/warranty-registration)

