

Parts Catalog



E300

Slicing Machine

Model: E300

03/22/2019 Rev A

IMPORTANT!

TO EXPEDITE SHIPMENT OF PARTS, ALWAYS SPECIFY MODEL, REV,
PART NUMBER, AND SERIAL NUMBER OF UNIT.

GLOBE FOOD EQUIPMENT COMPANY

2215 East River Road
Dayton, Ohio 45439

Parts Department

Toll Free 1-800-745-6238 · Fax (937) 290-0585

E-Mail: info@globefoodequip.com

Website: www.globefoodequip.com

Not for resale

Table of Contents

Description	Page
E300 Slicer Base Components	4
E300 Chute Components	6
E300 Knife & Sharpener Components	8
E300 Electrical Components	10
E300 Wiring Diagram	12



E300 Slicer Base Components

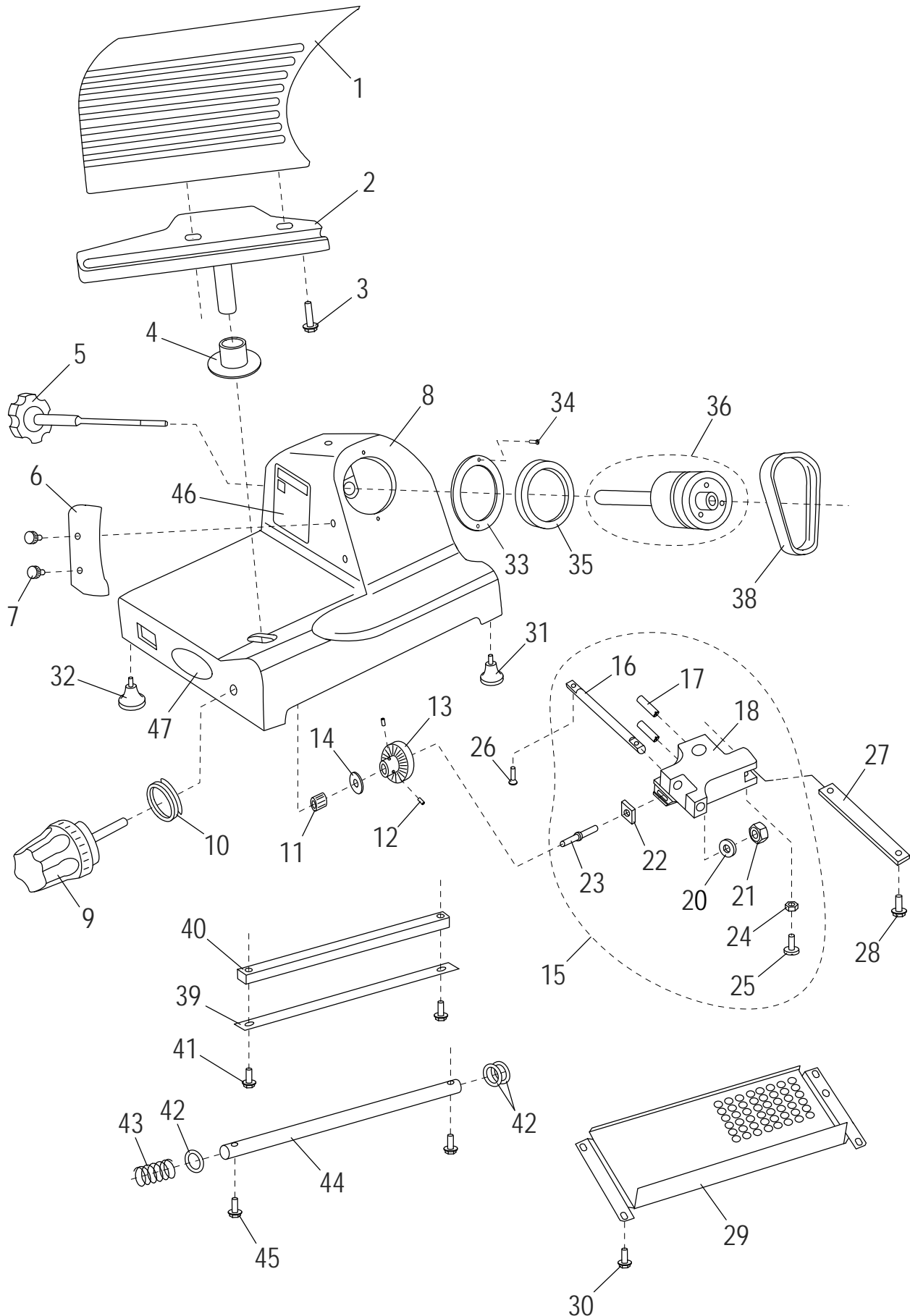



E300 Slicer Base Components

Item	Part Number	Description	Qty	Serial Number
1	G00068	Slicer Table	1	
2	G00073	Table Support Bracket	1	
3	H00046	Hex Head Screw M6 x 35 - Zn	2	
4	G00076	Base Hole Cover	1	
5	ET12	Cover Release Knob	1	
6	ET23	Deflector	1	
7	22-A	Deflector Screw	2	
8		Aluminium Base	1	
9	G00079	Index Knob	1	
10	G00081	V Seal, Index Knob	1	
11	G00082	Index Knob Sleeve	1	
12	H00047	Set Screw, M5x5 Flat Pt, Hex Socket - BO	2	
13	27	Indexing Cam	1	
14	H00066	Wavy Washer	1	
15	ET33	Table Adjustment Assembly	1	
16		Table Adjustment Shaft	1	
17	H00048	Set Screw, M8x8 Cup Pt, Hex Socket - BO	2	
18		Table Slide	1	
19		Bearing, Table Slide (Not Shown)	2	
20	H00014	Flat M6 Washer - Zn	1	
21	H00020	Hex Nut, M6	1	
22	H00044	Square Nut M6 - Zn	1	
23		Indexing Cam Conic Shaft	1	
24	H00028	Hex Nut M5 - Zn	1	
25	H00049	Screw, Slotted Cyl Hd M5x16 - Brass	1	
26	H00050	Cap Screw, M5 x 16 Flat Head - Zn	2	
27		Plate, Table Adjustment	1	
28	H00051	Cap Screw, Hex Washer Head M5 x 10 - Zn	2	
29	G00083	Bottom Cover	1	
30	H00051	Cap Screw, Hex Washer Head M5 x 10 - Zn	4	
31	D40	Rubber Foot, New Style	4	
32	G00085	Rubber Foot, Large	2	
33	ET52A	Washer, Knife Hub	1	
34	H00052	Screw Slotted Cyl Head M4 x 8 - Zn	2	
35	ET52C	V Seal, Drive Hub	1	
36	G00086	Drive Hub Assembly	1	
37	H00053	Retaining Ring, Internal (Not Shown)	1	
38	55	Drive Belt	1	
39	G00089	Wear Strip, Slide Bar	1	
40	43	Slide Bar	1	
41	H00055	Cap Screw, Hex Washer Head M5 x 23 - Zn	2	
42	H00058	O Ring \varnothing 4x17	3	
43	50-A	Spring, Slide Rod	1	
44	G00092	Slide Rod	1	
45	H00055	Cap Screw, Hex Washer Head M5 x 23 - Zn	2	
46	81	Warning Label	1	
47	83-A	Logo Label, Chefmate	1	

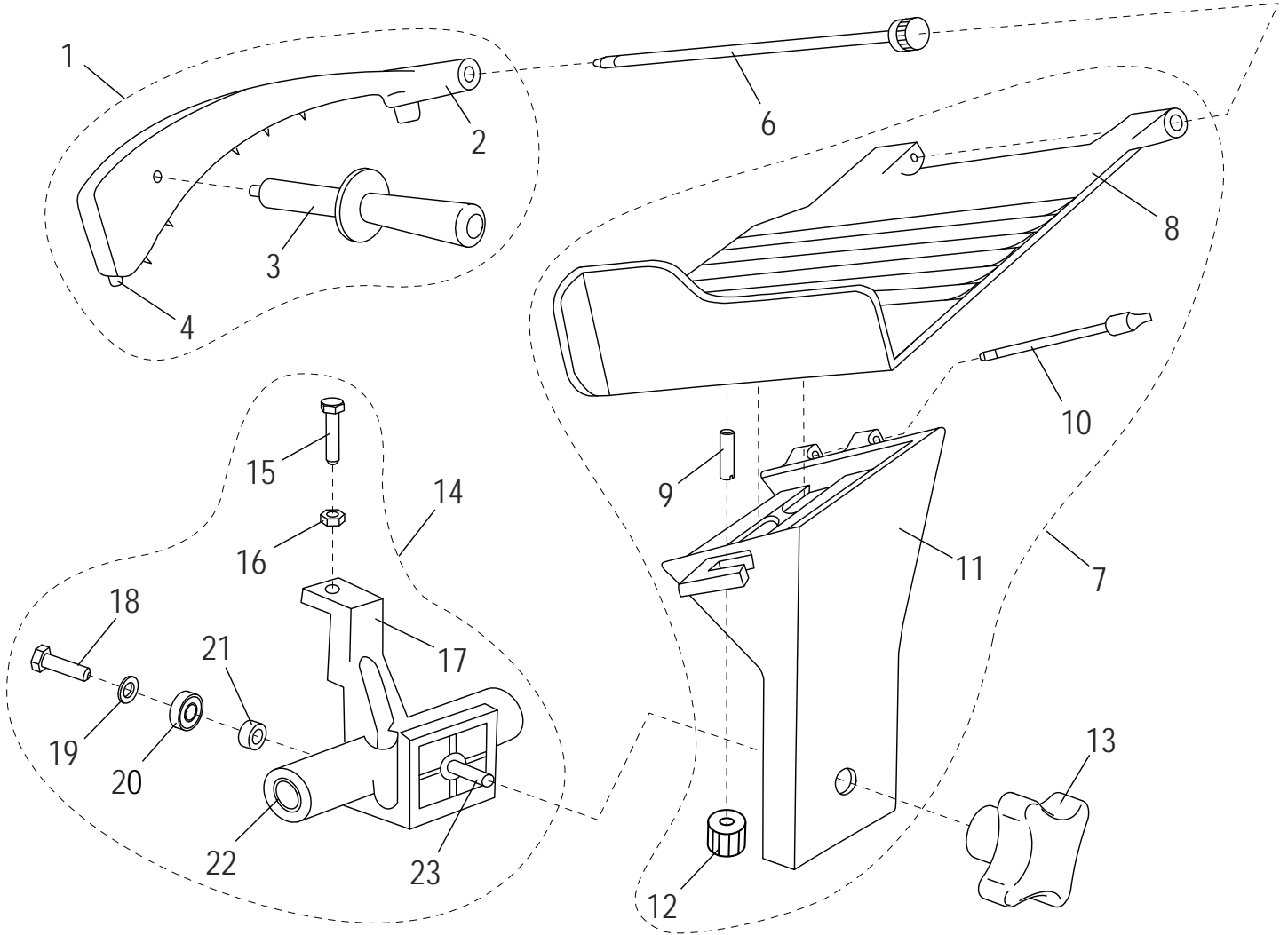



E300 Chute Components

Item	Part Number	Description	Qty	Serial Number
1	ET62	End Weight Assembly	1	
2		End Weight	1	
3	70-L	End Weight Handle	1	
4	ET64	White Plastic Bumber	1	
5		Bearing, End Weight (Not shown)	2	
6	G00126	End Weight Rod	1	
7	G00133	Chute Support Assembly	1	
8	G00129	Food Chute	1	
9	H00060	Set Screw, M6x16 Flat Pt Slotted - Zn	1	
10	G00137	Chute Unlock Shaft	1	
11	G00139	Chute Support	1	
12	G00141	Chute Unlock Knob	1	
13	72	Knob, Chute Support	1	
14	46	Chute Slide Assembly	1	
15	H00145	Screw, Hex Head M6 x 20 - Nylon	1	
16	H00020	Hex Nut, M6	1	
17		Chute Slide	1	
18	H00043	Hex Head Screw M6x25 - Zn	1	
19	H00014	Flat M6 Washer - Zn	1	
20	47-B	Bearing, Small	1	
21		Spacer	1	
22		Chute Slide Bearing (Not Shown)	2	
23	46-A	Chute Stud	1	



E300 Knife & Sharpener Components

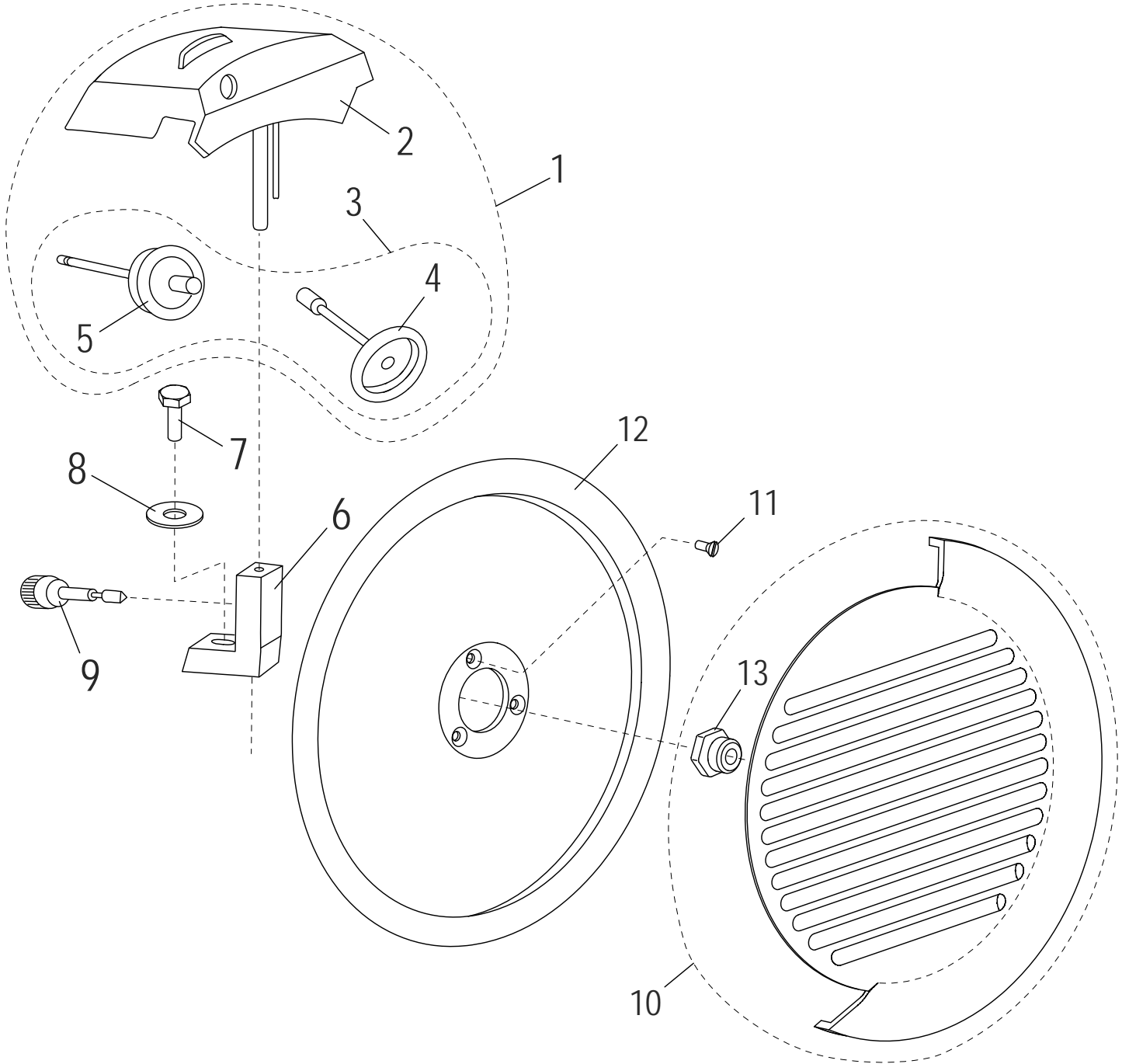



E300 Knife & Sharpener Components

Item	Part Number	Description	Qty	Serial Number
1	G00097	Knife Sharpener Assembly, Complete	1	
2	ET1	Sharpener Cover	1	
3	G00101	Sharpening/Truing Stone & Shaft Set	1	
4	G00103	Sharpening Stone (Coarse)	1	
5	G00106	Deburring Stone (Fine)	1	
6	ET9	Sharpener support	1	
7	H00118	Screw, Hex Head M8 x 22 - Zn	1	
8	H00121	Flat Washer, Large Diameter M8 x 20 x 2 - Zn	1	
9	10-B	Sharpener Adjustment Screw	1	
10	61	Knife Cover	1	
11	56-A	Screw, Knife Mounting	3	
12	58	Slicer Knife	1	
13	59-A	Knife Cover Insert	1	

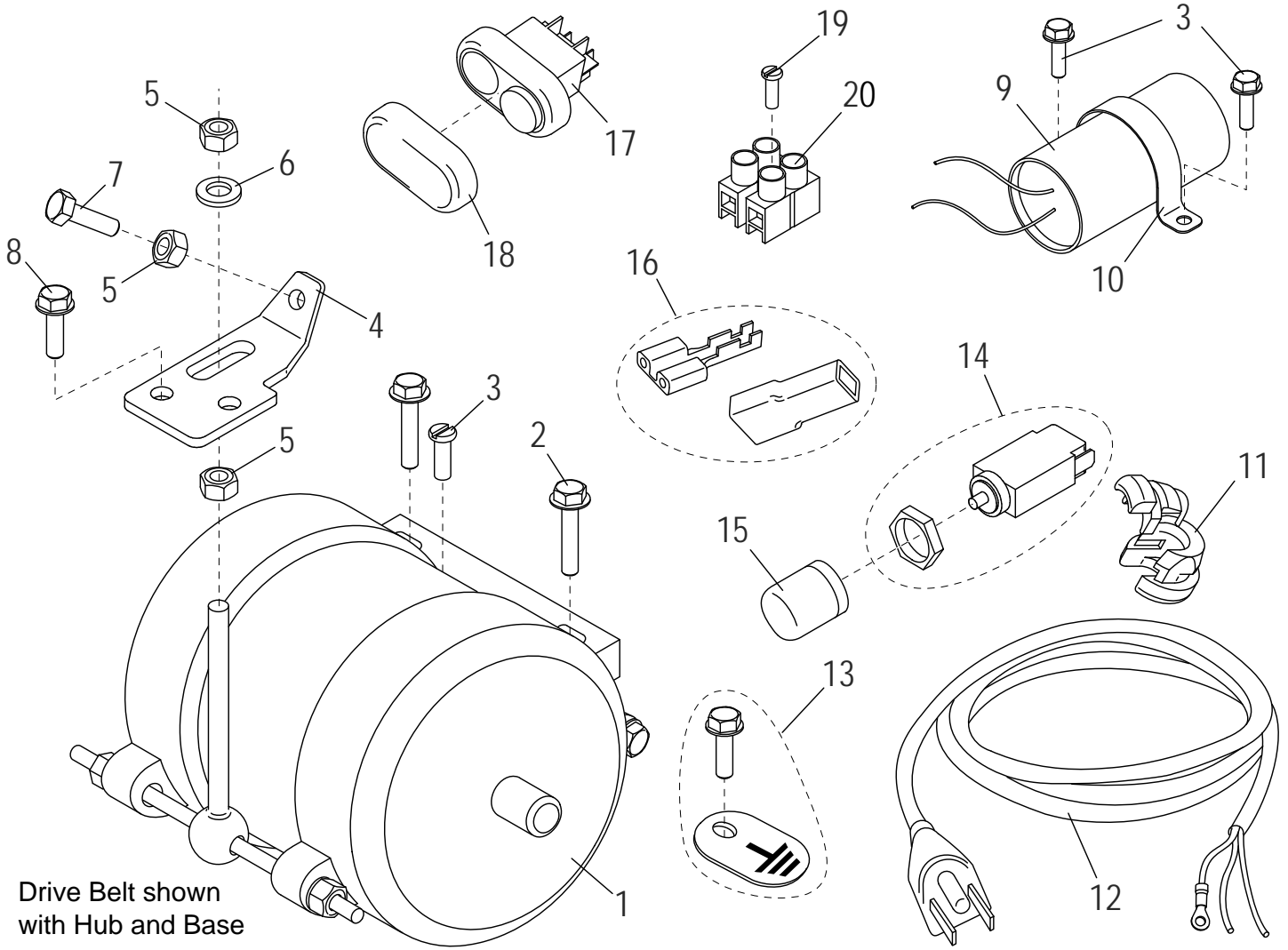

Drive Belt shown
with Hub and Base



E300 Electrical Components

Item	Part Number	Description	Qty	Serial Number
1	G00149	Motor	1	
2	H00051	Cap Screw, Hex Washer Head M5 x 10 - Zn	2	
3	H00061	Hex Head Screw M5x10, Zinc	1	
4		Belt Tightener Plate	1	
5	H00020	Hex Nut, M6	3	
6	H00014	Flat M6 Washer - Zn	1	
7	H00043	Hex Head Screw M6x25 - Zn	1	
8	H00051	Cap Screw, Hex Washer Head M5 x 10 - Zn	3	
9	ET31	Capacitor "Ducati UL"	1	
10		Capacitor Holder	1	
11	877	Strain Relief, Power Cord	1	
12	132-3	Power Cord	1	
13	G00152	Ground Screw/Marking Tab Set	1	
14	89	Reset Button with Cover	1	
15	G00154	Reset Button Cover	1	
16	G00167	Female Terminal & Insulator	6	
17	ET28-1	Power Switch	1	
18	G00153	Cover, Power Switch	1	
19	H00065	Terminal Block Mounting Screw, M2.9 x 13	1	
20	G00155	Terminal Block, 2 Position	1	



E300 Wiring Diagram

