



Model G12-Q



Model #: \_\_\_\_\_

Serial #: \_\_\_\_\_



## Instruction Manual for the Globe Slicer Models G12-Q & G14-Q

### Units Comply to the Following Canadian Standards

- EN1974
- UL763
- CSA, C22.2

### For Service on Your Slicer:

1. Visit our website at [www.globefoodequip.com](http://www.globefoodequip.com)
2. Or call the Globe service department at 937-299-8625 and ask for contact information for your local service company.

### **- IMPORTANT SAFETY NOTICE -**

This manual contains important safety instructions that must be strictly followed when using this equipment.

Visit our website for information on additional products available from Globe.

**[www.globefoodequip.com](http://www.globefoodequip.com)**

***Slicers, Mixers, Countertop Cooking Equipment, Meat Choppers & Scales***

WARRANTY REGISTRATION  
SCAN THE QR CODE WITH YOUR MOBILE DEVICE OR GO TO  
[WWW.GLOBEFOODEQUIP.COM](http://WWW.GLOBEFOODEQUIP.COM)  
TO FILL OUT AND SUBMIT YOUR WARRANTY REGISTRATION.

[WWW.GLOBEFOODEQUIP.COM/SUPPORT/WARRANTY-REGISTRATION-FORM](http://WWW.GLOBEFOODEQUIP.COM/SUPPORT/WARRANTY-REGISTRATION-FORM)

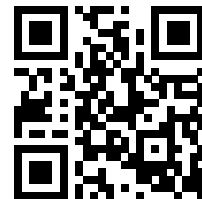



# Index

ATTENTION OWNERS AND OPERATORS.....	5
KEY COMPONENTS OF THE SLICER .....	6
GLOBE SLICER SAFETY TIPS .....	7
INSTALLATION .....	8-9
OPERATING INSTRUCTIONS.....	10-11
CLEANING .....	12-13
KNIFE SHARPENING .....	14-15
SIMPLE MAINTENANCE AND REPAIR.....	16-17
TROUBLESHOOTING GUIDE .....	18
LIMITED SLICER WARRANTY .....	20



**GLOBE FOOD EQUIPMENT CO.**  
**2153 DRYDEN RD.**  
**DAYTON, OH 45439**  
**Toll Free: 800-347-5423**  
**PHONE: 937-299-5493**  
**FAX: 937-299-8623**  
**E-MAIL: [info@globefoodequip.com](mailto:info@globefoodequip.com)**  
**WEBSITE: [www.globefoodequip.com](http://www.globefoodequip.com)**



# Attention Owners and Operators

Globe's equipment is designed to provide safe and productive processing of food products as long as the equipment is used in accordance with the instructions in this manual and is properly maintained. Importantly, unless the operator is adequately trained and supervised, there is a possibility of serious injury. Owners of this equipment bear the responsibility to make certain that this equipment is used properly and safely, strictly following all the instructions contained in this manual and the requirements of local, state or federal law.

Owners should not permit anyone to touch this equipment unless they are over 18 years of age, are adequately trained and supervised and have read and understood this manual. Owners should also ensure that no customers, visitors or other unauthorized personnel come in contact with this equipment. Please remember that Globe cannot anticipate every circumstance or environment in which its equipment will be operated. It is the responsibility of the owner and the operator to remain alert to any hazards posed by the function of this equipment, particularly the sharp knife blade and all moving parts. If you are uncertain about a particular task or the proper method of operating this equipment, ask your supervisor.

This manual contains a Safety Tips section listing a number of precautions to follow to help promote safe use of this equipment. Throughout the manual you will see additional warnings to help alert you to potential hazards.

**Warnings affecting your personal safety are indicated by:**



**Warnings related to possible damage to the equipment are indicated by:**



Make certain the instruction manual is available for easy reference by any operator. Globe has put a warning label in the English language on the slicer. Spanish warning labels are available upon request to Globe. If the warning label or manual becomes misplaced, damaged, illegible or if you require additional copies, please contact your nearest representative or Globe directly.

Please remember that this manual and the warning label do not replace the need to be alert, to properly train and supervise operators and to use common sense when using this equipment.

# Key Components of the Slicer

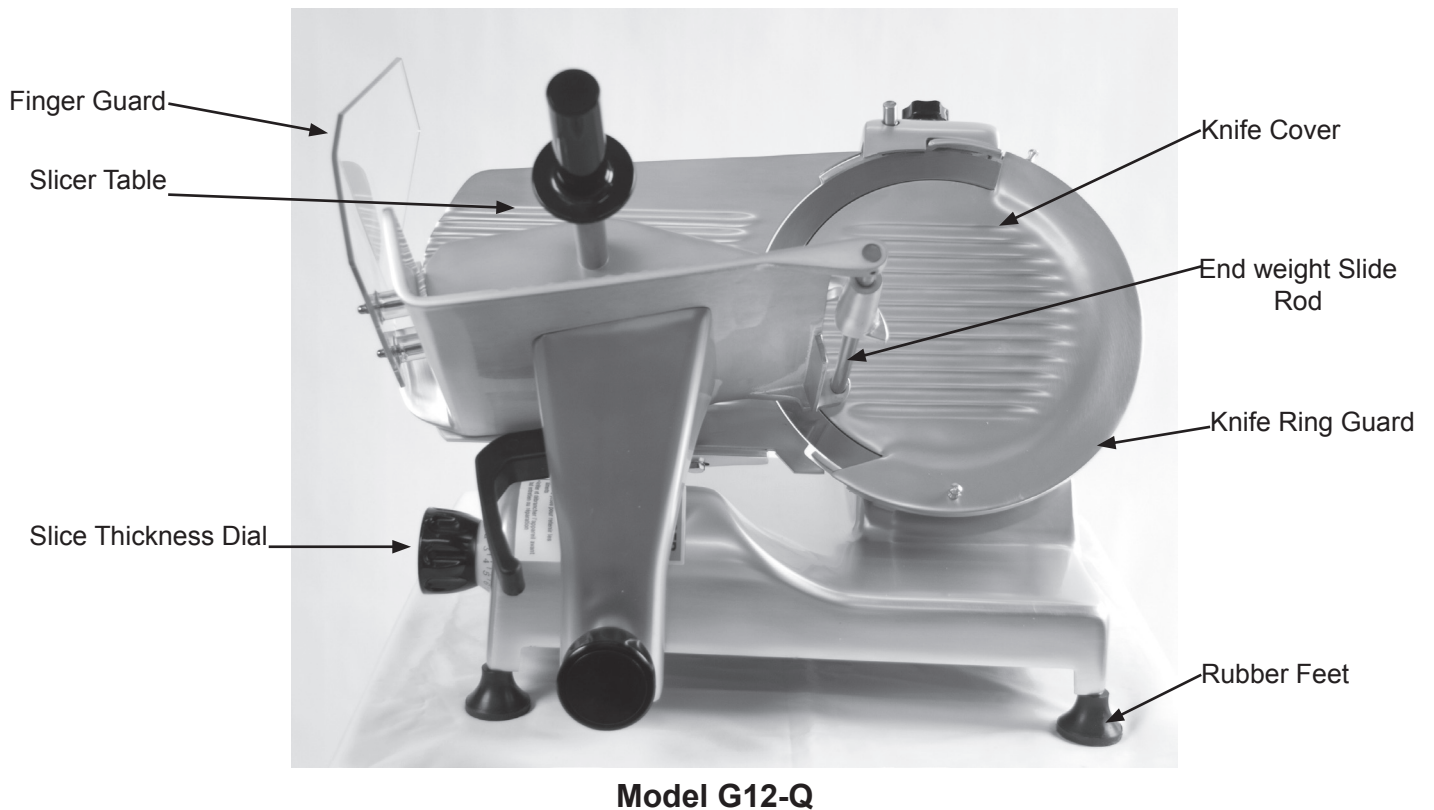

## Globe Slicer Safety Tips



# SHARP KNIFE BLADE

### TO AVOID SERIOUS PERSONAL INJURY:

- **NEVER** touch this slicer without training and authorization from your supervisor or if you are under 18 years of age. Read this instruction manual first.
- **ONLY** install the slicer on a solid level, nonskid surface that is nonflammable and is located in a clean, well-lit work area away from children and visitors.
- **ALWAYS** ground slicer utilizing proper power source.
- **NEVER TOUCH KNIFE.** Keep hands and arms away from all moving parts.
- **NEVER OPERATE** slicer without knife cover and knife ring guard securely installed.
- **NEVER** put hand into the chute arm opening on the right side of the slicer.
- **ONLY USE FOOD CHUTE HANDLE** to push the food chute during manual slicing.
- **ONLY USE THE END WEIGHT HANDLE, NOT YOUR HAND** to hold food products when slicing. Never put your hand on or around, food chute when slicer is on.
- **DO NOT CATCH SLICES WITH YOUR HAND.** Let slices drop onto the receiving area.
- **ALWAYS** turn slicer off and turn the slice thickness dial clockwise until it stops after each use.
- **BEFORE CLEANING, SHARPENING, SERVICING, OR REMOVING ANY PARTS** always turn slicer off, turn the slice thickness dial clockwise until it stops, remove food chute and unplug power cord.
- **USE ONLY PROPERLY INSTALLED GLOBE SLICER ACCESSORIES.**

# Installation

## UNPACKING

1. Unpack the slicer immediately after receipt. If the machine is found to be damaged, save the packaging material and contact the carrier within fifteen (15) days of delivery. Immediately contact your source of the equipment. **You have no recourse for damage after fifteen (15) days.**
2. You should receive rubber feet, a warranty card, and an instruction manual with the slicer. Contact Globe, or your local supplier, if you did not receive all of these materials.



## **TO AVOID SERIOUS PERSONAL INJURY PROPERLY INSTALL SLICER IN ADEQUATE WORK AREA**

- **ALWAYS** install equipment in a work area with adequate light and space.
- **ONLY** operate on a solid, level, nonskid surface that is nonflammable.
- **NEVER** operate slicer with a damaged power cord or power plug.
- **NEVER** operate slicer with an extension cord.
- **NEVER** bypass, alter or modify this equipment in any way from its original condition. Doing so may create hazards and will void warranty.
- **NEVER** operate slicer without the knife cover and knife ring guard securely installed.
- **NEVER** operate slicer without the warning label attached to slicer (see page 6 for location) and Globe wall chart posted.

## INSTALLATION:

1. Read this manual thoroughly before installation and operation. **DO NOT** proceed with installation and operation if you have any questions or do not understand anything in the manual. Contact your local representative or Globe **first**.
2. Remove the slicer from the corrugated box.
3. Make sure the rubber feet are firmly tightened.



**NEVER USE SLICER WITHOUT RUBBER FEET ON UNIT.**

4. Select a location for the slicer that has a level, solid, nonskid surface that is nonflammable and is in a well-lighted work area that is away from children and visitors.



**USE AT LEAST TWO PEOPLE TO LIFT THE SLICER UP TO THE OPERATING LOCATION. NEVER ATTEMPT TO LIFT THE SLICER ALONE.**



# Installation



**THIS MACHINE IS PROVIDED WITH A THREE-PRONG GROUNDING PLUG. THE OUTLET TO WHICH THIS PLUG IS CONNECTED MUST BE PROPERLY GROUNDED. IF THE RECEPTACLE IS NOT THE PROPER GROUNDING TYPE, CONTACT AN ELECTRICIAN. DO NOT, UNDER ANY CIRCUMSTANCES, CUT OR REMOVE THE THIRD GROUND PRONG FROM THE POWER CORD OR USE ANY ADAPTER PLUG (Fig. 9-1 and Fig. 9-2).**

5. Inspect the slicer to ensure all parts have been provided.
6. Make sure the knife cover, knife ring guard and knife sharpener are in place.
7. Make sure the warning label is properly positioned and legible and the instruction manual is available near the slicer.
8. Complete warranty registration online at [www.globefoodequip.com/support/warranty-registration-form](http://www.globefoodequip.com/support/warranty-registration-form).
9. Clean the slicer using the procedures outlined in the cleaning section (pages 12 and 13) prior to using the slicer.
10. Contact your local representative or Globe directly if you have any questions or problems with the installation or operation of this slicer.



Figure 9-1 Correct



Figure 9-2 **INCORRECT**

# Operating Instructions



## SHARP KNIFE BLADE

### TO AVOID SERIOUS PERSONAL INJURY:

- **NEVER** touch this slicer without training and authorization from your supervisor or if you are under 18 years of age. Read this instruction manual first.
- **NEVER TOUCH KNIFE.** Keep hands and arms away from all moving parts.
- **NEVER OPERATE** slicer without knife cover and knife ring guard securely installed.
- **NEVER** put hand into the chute arm opening on the right side of the slicer.
- **ONLY USE FOOD CHUTE HANDLE** to push the food chute during manual slicing.
- **ONLY USE THE END WEIGHT, NOT YOUR HAND** to hold food products when slicing.
- **NEVER** put your hand on or around, food chute when slicer is on.
- **DO NOT CATCH SLICES WITH YOUR HAND.** Let slices drop onto the receiving area.
- **ALWAYS** turn slicer off and turn the slice thickness dial clockwise until it stops after each use.
- **BEFORE CLEANING, SHARPENING, SERVICING OR REMOVING ANY PARTS** always turn slicer off, turn the slice thickness dial clockwise until it stops, unplug the power cord and remove the food chute.

### MANUAL SLICER OPERATION

1. With the slicer turned off, pull the food chute completely towards you and place the food product onto the food chute. Slice only boneless, unfrozen product with the slicer. Use the end weight to hold the food product in place.
2. Make sure all knobs are tightened prior to using the slicer.
3. Rotate the slice thickness dial counterclockwise to the desired setting. After slicing is complete, turn the slice thickness dial clockwise until it stops to close the slicer table.
4. Turn the slicer on by pushing the start button. The power indicator light will illuminate (see page 6 for location).

# Operating Instructions

 **DO NOT** hold the food product with your hand. Never put your hand on or around food chute when slicer is on. The food chute handle is the only part of the slicer you should touch while slicing.

5. Use the food chute handle to manually push the food chute back and forth. The food chute handle is the only part of the slicer you should touch while slicing. Do not catch slices with your hand. Let slices drop onto the receiving area.

 If a product needs to be adjusted during slicing, **ALWAYS** pull the food chute all the way towards you. Turn off slicer, and close slicer table prior to adjusting the product and the end weight.

6. After the last slice stroke, pull the food chute all the way towards you. Turn the slicer off by pushing the stop button. The power indicator light will go out. Always turn slice thickness dial clockwise until it stops to close the slicer table.

7. Now you can unload and load food product from the food chute.

Make sure all **WARNING LABELS** are in place. It is important to properly follow the warnings on this machine. Pay close attention to where loose items on your person are and the placement of your hands/fingers when operating and cleaning this machine.

**WARNING**  
**SHARP KNIFE BLADE  
TO AVOID SERIOUS INJURY**

- Do Not Use Without Training Or If Under 18 Years Old.
- Read Owner's Manual First.
- Keep Hands Away From Knife.
- Do Not Use Without Guards In Place.
- Use End Weight To Hold Food.
- Turn Off and Unplug Before Cleaning Or Servicing.

**DANGER**  
**LAME DE COUTEAU  
TRANCHANT  
AFIN D'ÉVITER TOUTE  
BLESSURE SÉRIEUSE**

- Ne pas utiliser sans avoir eu la formation nécessaire ou si moins de 18 ans
- Lire le manuel d'instruction avant l'utilisation
- Garder les mains éloignées du couteau
- Ne pas utiliser si les protecteurs de lame ne sont pas en place
- Utiliser la pesée pour retenir les aliments
- Arrêter et débrancher l'appareil avant tout entretien ou réparation

# Cleaning

## ⚠ WARNING



## SHARP KNIFE BLADE

TO AVOID SERIOUS PERSONAL INJURY TO THE SLICER OPERATOR AND CUSTOMERS:

- **BEFORE CLEANING, SHARPENING, SERVICING OR REMOVING ANY PARTS** always turn slicer OFF, turn the slice thickness dial clockwise until it stops and unplug the power cord.
- **NEVER** attempt to clean slicer with the knife running.
- **NEVER** attempt to remove the knife or knife ring guard from the slicer. They must remain on the slicer for proper operation, sharpening and cleaning.

⚠ The entire slicer, including removable parts, must be thoroughly cleaned and sanitized using the procedures identified by your local health department and the ServSafe Essentials published by the National Restaurant Association Educational Foundation (NRAEF). Visit [www.servsafe.com](http://www.servsafe.com) for more details.

⚠ It is extremely important to sanitize the slicer and to closely follow the instructions on your quaternary sanitizer container to ensure proper sanitation is achieved to kill potentially harmful bacteria.

## ⚠ CAUTION

- **DO NOT** put components in dishwasher.
- **DO NOT** hose down, pressure wash or pour water on the slicer.
- **NEVER** use a scrubber pad, steel wool or abrasive material to clean the slicer.
- **DO NOT** use bleach, products containing sodium hypochlorite or other caustic/strong detergents on the slicer base or removable parts. These products will discolor and destroy the parts.

Slicer components are easily disassembled without the use of special tools. It may be desirable to wear non-cutting safety gloves during the cleaning operation.

## DISASSEMBLY & CLEANING

1. Turn the slicer off, turn the slice thickness dial clockwise past 'zero' until it stops so the table covers the knife's edge and unplug the power cord.
2. Pull the food chute to the front of the slicer and then remove it by rotating the food chute release knob (Fig. 12-1) counterclockwise several times. (Note: The food chute **must be** pulled to the front of the slicer for removal.) Lift the food chute off the support.
3. The slice deflector can be removed by loosening the screw knobs (Fig. 12-2).



Figure 12-1



Figure 12-2

# Cleaning



**BE ALERT. The next steps will expose the knife.**  
**ALWAYS turn slicer off and unplug power cord BEFORE cleaning.**

4. Remove the knife cover by rotating the knife cover release knob counterclockwise until it releases (Fig. 13-1). While holding the knobs on the knife cover, carefully lift the knife cover upward to remove.

NOTE: The slicer will not start with the knife cover removed.

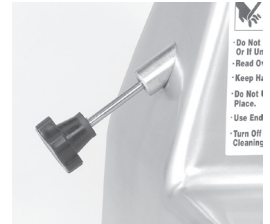

Figure 13-1

5. Take the food chute and knife cover to a three compartment sink. Soak, clean and scrub all surfaces of the food chute and knife cover using a solution of mild detergent and warm water. Rinse removed parts with fresh, clean water. Following the instructions on your quaternary sanitizer label, soak the food chute and knife cover in a proper solution of quaternary sanitizer for a minimum of two minutes.

**An important step to kill bacteria is to allow the parts to air dry before reassembly!**



Figure 13-2

6. To clean the knife, soak a clean cloth in a mild detergent and warm water solution. Ring out excess water from cloth. **Carefully** wash and rinse the top and bottom (underside) of the knife by wiping from the **center of the knife outward** (Fig. 13-2).



**DO NOT allow moisture to get into knife hub.**

7. To clean the knife ring guard, soak a clean cloth in a mild detergent and warm water solution. **Carefully** insert the cloth between the knife and the knife ring guard (Fig. 13-3). While holding the cloth between the knife and the knife ring guard, work it along the entire backside of the knife. A nylon brush could also be used if preferred.



Figure 13-3

8. To clean the slicer table, soak a clean cloth in a mild detergent and warm water solution. With the slicer table completely closed, scrub and wipe the slicer table by starting at the knife and pulling towards you. Never wipe the slicer table towards the knife.
9. With a clean cloth and brush, wipe down slicer to remove any food particles. Wipe and scrub all surfaces using a solution of warm water and detergent.
10. Use clean, fresh warm water and a clean cloth to wipe down the entire slicer to remove detergent.
11. Spray both sides of the knife, slicer table and the entire slicer base with a non-bleach, non-chlorine sanitizer following the instructions on your quaternary sanitizer container to ensure proper sanitation is achieved.  
**An important step to kill bacteria is to allow the parts to air dry before reassembly!**

## **REASSEMBLY**

1. Carefully reinstall the cleaned, sanitized and dry knife cover. Hold the knife cover with one hand while securely tightening the knife cover release knob with the other hand.
2. Place the cleaned, sanitized and dry food chute back onto the chute arm. Tighten the food chute release knob securely to prevent any “play” between the food chute and the chute arm.
3. Plug in the power cord.

**NOTE:** If you wish to remove the knife sharpener for cleaning, refer to page 17 for instructions.

# Knife Sharpening

**WARNING**



## SHARP KNIFE BLADE

### TO AVOID SERIOUS PERSONAL INJURY:

- **NEVER** touch rotating knife.
- **ALWAYS** keep hands clear of all moving parts.
- **ALWAYS** turn slicer off and turn slice thickness dial clockwise until it stops and remove the food chute before sharpening.
- **NEVER** sharpen slicer unless all guards are installed.

### WHEN AND HOW OFTEN TO SHARPEN THE KNIFE

1. Indications of a dull knife are excess waste or a “tail” on the unsliced portion remaining in the food chute.
2. The knife needs to be sharpened periodically to provide consistent slices and maximum food product yield. Sharpening the knife lightly every few days is more effective than heavy sharpening at less frequent intervals.

### PREPARING TO SHARPEN

1. Turn the slicer off and turn the slice thickness dial clockwise until it stops so the slicer table covers the knife's edge.
2. Remove food chute from the slicer.
3. Clean and dry both sides of the knife before sharpening, following instructions for knife cleaning on pages 12 and 13.

NOTE: The knife cover must be on during sharpening. The slicer will not start if the knife cover is removed.

4. Loosen the sharpener release knob by turning it counterclockwise several times (Fig. 14-1).



Figure 14-1



Figure 14-2



Figure 14-3



**BE ALERT. The next step will expose the knife.**

5. Lift the sharpener cover up (Fig. 14-1), rotate it clockwise (Fig. 14-2) and lower it into position with the knife fitting between the two stones (Fig. 14-3).
6. Tighten the sharpener release knob (Fig. 14-1) to secure the sharpener.

# Knife Sharpening

## SHARPENING THE KNIFE - (Regular Procedure)

1. Start the slicer.
2. Push the grinding stone button #2 (Fig. 15-1) and the honing stone button #3 (Fig. 15-2) at the same time so both stones make contact with the knife. Maintain pressure on the buttons for 5-10 seconds.



**TURN SLICER OFF before inspecting.**

## SHARPENING THE KNIFE - (Extended Procedure)

**NOTE: Use the extended procedure if the regular sharpening procedure does not produce satisfactory results.**

1. Start the slicer.
2. Push the grinding stone button #2 (Fig. 15-1) so the stone sharpens the back side of the knife. Maintain pressure on the button for 30 seconds.
3. Push the grinding stone button #2 (Fig. 15-1) and the honing stone button #3 (Fig. 15-2) at the same time so both stones make contact with the knife. Maintain pressure on the buttons for 5 seconds.



**TURN SLICER OFF before inspecting.**

## AFTER SHARPENING

1. Turn the slicer off and unplug the power cord.
2. Loosen the sharpener release knob.
3. Rotate the sharpener and place it back in its stored position (Fig. 15-3).
4. Tighten the sharpener release knob.
5. Clean the entire slicer as described on pages 12 and 13.
6. Reinstall the food chute and plug the power cord in.

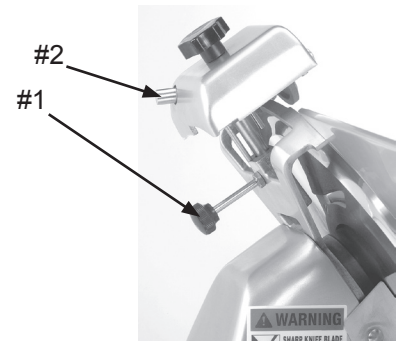

Figure 15-1



Figure 15-2

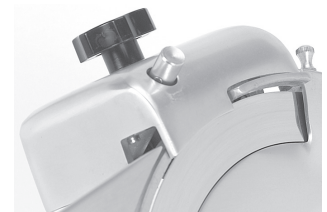

Figure 15-3



# Simple Maintenance and Repair

## **⚠ WARNING**



## **SHARP KNIFE BLADE**

### **TO AVOID SERIOUS PERSONAL INJURY:**

- **ALWAYS** turn off slicer and unplug slicer before servicing.
- **NEVER** touch this slicer without training and authorization from your supervisor.
- **ALWAYS** keep hands clear of rotating knife and moving parts.
- **DO NOT** tamper with, bypass or remove any safety devices, guards, or switches.
- **ALWAYS** turn off slicer and turn slice thickness dial completely clockwise after each use.
- **USE ONLY Globe** parts and accessories properly installed.

### **LUBRICATION**

Various slicer parts need to be lubricated periodically using Globe oil. Globe oil is a light, tasteless, odorless mineral oil that will not contaminate or impart odors or taste to sliced food products.

## **⚠ CAUTION**

**DO NOT USE VEGETABLE OIL TO LUBRICATE SLICER.  
VEGETABLE OIL WILL DAMAGE THE SLICER!**

### **Food Chute Slide Rod**

It is necessary to lubricate the food chute slide rod with Globe oil if the food chute becomes difficult to push.

1. Unplug the slicer and remove the food chute.
2. Tilt the slicer on its end. Unscrew the four rubber feet to remove the slicer cover.
3. Put several drops of Globe oil on the slide rod (Fig. 16-1) towards the top of the rod.
4. Tilt the slicer back to its normal position.
5. Push the food chute back and forth several times to distribute the oil onto the slide rod.
6. Reinstall the food chute.
7. Plug the slicer in.

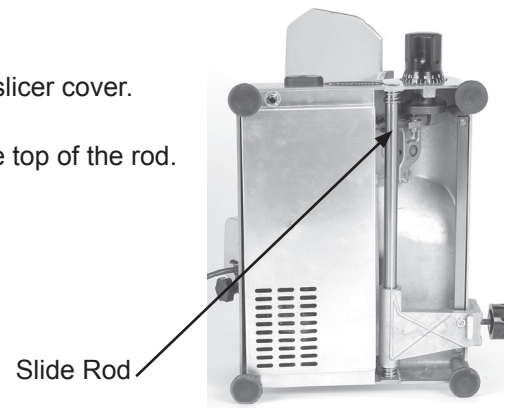

Figure 16-1



# Simple Maintenance and Repair

## CAUTION

**DO NOT USE VEGETABLE OIL TO LUBRICATE SLICER.  
VEGETABLE OIL WILL DAMAGE THE SLICER!**

### Sharpener Shafts

It is necessary to lubricate the sharpener shafts with Globe oil weekly.

1. Loosen the sharpener release knob and pull the sharpener up to remove it (Fig. 17-1).
2. Put several drops of Globe oil on the shaft behind each sharpening stone (Fig 17-2).
3. Push both sharpener buttons a couple of times to distribute the oil onto the shafts.
4. Put several drops of Globe oil on the main shaft (Fig. 17-1), place the sharpener back into position and tighten the sharpener release knob.
5. Wipe off any excess oil that drips onto the slicer.

NOTE: The sharpener and stones can be cleaned with warm water and a brush. Allow it to air dry. **If the sharpener or stones are cleaned it is very important that all sharpener shafts are lubricated with Globe oil afterwards!**

### End Weight Slide Rod

The end weight slide rod should be lubricated with a few drops of Globe oil weekly or when excessive drag is felt.

1. Apply a few drops of Globe oil to the slide rod (Fig. 17-3).
2. Slide the end weight up and down to distribute the oil.

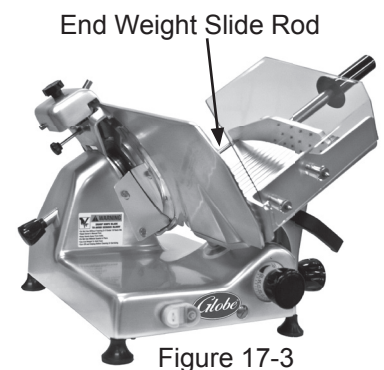
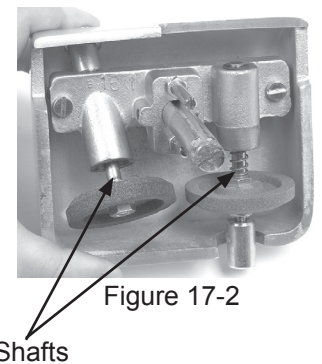
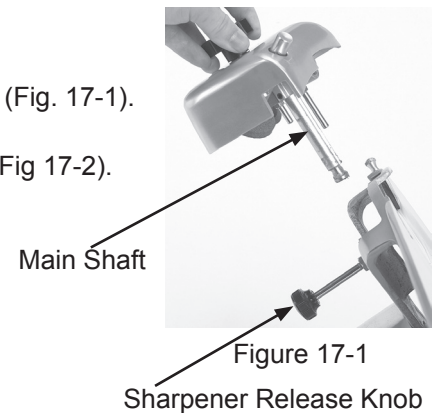

**Globe recommends that an authorized Globe service company perform all adjustments and major maintenance.**

**By adequately maintaining your slicer,  
it will provide years of dependable service.**

# Troubleshooting Guide

PROBLEM	CAUSE	SOLUTION
Slicer will not start	<p>Slicer not plugged in</p> <p>Knife cover removed or not properly installed</p> <p>Motor reset button tripped</p>	<p>Plug in slicer</p> <p>Install knife cover and tighten the knife cover release knob</p> <p>Press the motor reset button located underneath the slicer</p>
Ragged cuts-poor yield	<p>Dull knife</p> <p>Chipped knife</p> <p>Knife-slicer table gap too wide</p> <p>Knife too small</p>	<p>Sharpen knife-make sure knife and stones are clean</p> <p>Sharpen or have new knife installed</p> <p>Call for service to adjust slicer table</p> <p>Have new knife installed</p>
Metal rubbing knife	<p>Knife cover</p> <p>Food chute</p> <p>End weight</p> <p>Slicer table</p>	<p>Tighten knife cover release knob</p> <p>Tighten or adjust food chute knob</p> <p>Have defective end weight replaced</p> <p>Call for service to adjust slicer table</p>
Hard to push food chute	No lubrication	Lubricate slide rods thoroughly with Globe oil. <b>No vegetable oil!</b>
Hard to sharpen	<p>Stones dirty, wet or clogged with grease</p> <p>Knife dirty</p> <p>Worn stones</p> <p>Stones not properly aligned</p>	<p>Clean stones with warm water and a brush. Allow stones to air dry. Lubricate shafts with Globe oil afterwards.</p> <p>Clean top and bottom of knife</p> <p>Have stones replaced</p> <p>Have sharpener adjusted</p>
Slicer stops running	Motor overheated	Wait 10-15 minutes for slicer to cool down. Push the reset button, then start the slicer.



# Limited Slicer Warranty

Globe Food Equipment Company (“GFE”) warrants to the original purchaser of new equipment that said equipment, when installed in accordance with our instructions within North America and subjected to normal use, is free from defects in material or workmanship for a period of 1 year from installation or 18 months from actual shipment date, whichever date occurs first.

THIS WARRANTY IS IN LIEU OF ALL OTHER WARRANTIES, WHETHER EXPRESSED OR IMPLIED. GFE EXPRESSLY DISCLAIMS ANY IMPLIED WARRANTY OF MERCHANTABILITY OR EXPRESSED OR IMPLIED WARRANTY OF FITNESS FOR A PARTICULAR PURPOSE.

GFE’S OBLIGATION AND LIABILITY UNDER THIS WARRANTY IS EXPRESSLY LIMITED TO REPAIRING AND REPLACING EQUIPMENT WHICH PROVES TO BE DEFECTIVE IN MATERIAL OR WORKMANSHIP WITHIN THE APPLICABLE WARRANTY PERIOD. All repairs pursuant to this Warranty will be performed by an Authorized Designated GFE Service Location during normal working hours. IN NO EVENT SHALL GFE BE LIABLE FOR INCIDENTAL OR CONSEQUENTIAL DAMAGES TO BUYER OR ANY THIRD PARTY, INCLUDING, WITHOUT LIMITATION, LOSS OF PROPERTY, PERSONAL INJURY, LOSS OF BUSINESS OR PROFITS OR OTHER ECONOMIC LOSSES, OR STATUTORY OR EXEMPLARY DAMAGES, WHETHER IN NEGLIGENCE, WARRANTY, STRICT LIABILITY OR OTHERWISE.

This warranty is given only to the first purchaser from a retail dealer. No warranty is given to subsequent transferees.

This warranty does not cover product failures caused by: failure to maintain, neglect, abuse, damage due to excess water, fire, normal wear, improper set up and use. Periodic maintenance including lubrication and sharpening are not covered.

This warranty is not in force until such time as a properly completed and signed installation/warranty registration or an online registration form has been received by GFE within 30 days from the date of installation. Register online at [www.globefoodequip.com/support/warranty-registration-form](http://www.globefoodequip.com/support/warranty-registration-form).

THE FOREGOING WARRANTY PROVISIONS ARE A COMPLETE AND EXCLUSIVE STATEMENT BETWEEN THE BUYER AND SELLER. GFE NEITHER ASSUMES NOR AUTHORIZES ANY PERSONS TO ASSUME FOR IT ANY OTHER OBLIGATION OR LIABILITY IN CONNECTION WITH SAID EQUIPMENT.

Example of items not covered under warranty, but not limited to just these items:

1. Acts of God, fire, water damage, burglary, accident, theft, vandalism.
2. Freight damage.
3. Improper installation or alteration of equipment.
4. Use of generic or after market parts.
5. Repairs made by anyone other than a GFE designated servicer.
6. Lubrication.
7. Expendable wear parts, knife, stones, rubber boots, blown fuses, lamps.
8. Cleaning of equipment.
9. Misuse or abuse.

WARRANTY REGISTRATION  
SCAN THE QR CODE WITH YOUR MOBILE DEVICE OR GO TO  
[WWW.GLOBEFOODEQUIP.COM](http://WWW.GLOBEFOODEQUIP.COM)  
TO FILL OUT AND SUBMIT YOUR WARRANTY REGISTRATION.

[WWW.GLOBEFOODEQUIP.COM/SUPPORT/WARRANTY-REGISTRATION-FORM](http://WWW.GLOBEFOODEQUIP.COM/SUPPORT/WARRANTY-REGISTRATION-FORM)

