



Model GC12BA



Model GC12B



Model #: _____

Serial #: _____



Instruction Manual for the Chefmate Slicer Models GC12B and GC12BA

For Service on Your Slicer

1. Visit our website at www.globeslicers.com (select Service button)
2. Or...Call Globe service department at 937-297-7247 and ask for the contact information for your local service company

Visit our website for information on additional products available from Globe.

www.globeslicers.com

Slicers, Mixers, Vegetable Cutters, Meat Choppers, and Scales

- IMPORTANT SAFETY NOTICE -

This manual contains important safety instructions which must be strictly followed when using this equipment.

Index

ATTENTION OWNERS AND OPERATORS.....	3
KEY COMPONENTS OF THE SLICER	4
CHEFMATE SLICER SAFETY TIPS	5
INSTALLATION	6-7
OPERATING INSTRUCTIONS.....	8-9
CLEANING	10-11
KNIFE SHARPENING	12-13
SIMPLE MAINTENANCE AND REPAIR.....	14-15
TROUBLESHOOTING GUIDE	16
LIMITED SLICER WARRANTY	17



GLOBE FOOD EQUIPMENT CO.
2153 DRYDEN RD.
DAYTON, OH 45439
PHONE: 937-299-5493
FAX: 937-299-8623
E-MAIL: globeinfo@globeslicers.com
WEBSITE: www.globeslicers.com

© Globe Food Equipment Company, 2007

Printed in the U.S.A.

11-2007

Attention Owners and Operators

Globe's equipment is designed to provide safe and productive processing of food products as long as the equipment is used in accordance with the instructions in this manual and is properly maintained. Importantly, unless the operator is adequately trained and supervised, there is a possibility of serious injury. Owners of this equipment bear the responsibility to make certain that this equipment is used properly and safely, strictly following all the instructions contained in this manual and the requirements of local, state or federal law.

Owners should not permit anyone to touch this equipment unless they are over 18 years old, are adequately trained and supervised, and have read and understood this manual. Owners should also ensure that no customers, visitors or other unauthorized personnel come in contact with this equipment. Please remember that Globe cannot anticipate every circumstance or environment in which its equipment will be operated. It is the responsibility of the owner and the operator to remain alert to any hazards posed by the function of this equipment, particularly the sharp knife blade and all moving parts. If you are ever uncertain about a particular task or the proper method of operating this equipment, ask your supervisor.

This manual contains a safety tips section listing a number of precautions to follow to help promote safe use of this equipment. Throughout the manual you will see additional warnings to help alert you to potential hazards.

Warnings affecting your personal safety are indicated by:



Warnings related to possible damage to the equipment are indicated by:



Make certain the instruction manual is available for easy reference by any operator. Globe has put a warning label in the English language on the slicer. Spanish warning labels are available upon request to Globe. If the warning label or manual becomes misplaced, damaged, or illegible, or if you require additional copies, please contact your nearest representative or Globe directly.

Please remember that this manual and the warning label do not replace the need to be alert, to properly train and supervise operators, and to use common sense when using this equipment.

Key Components of the Slicer

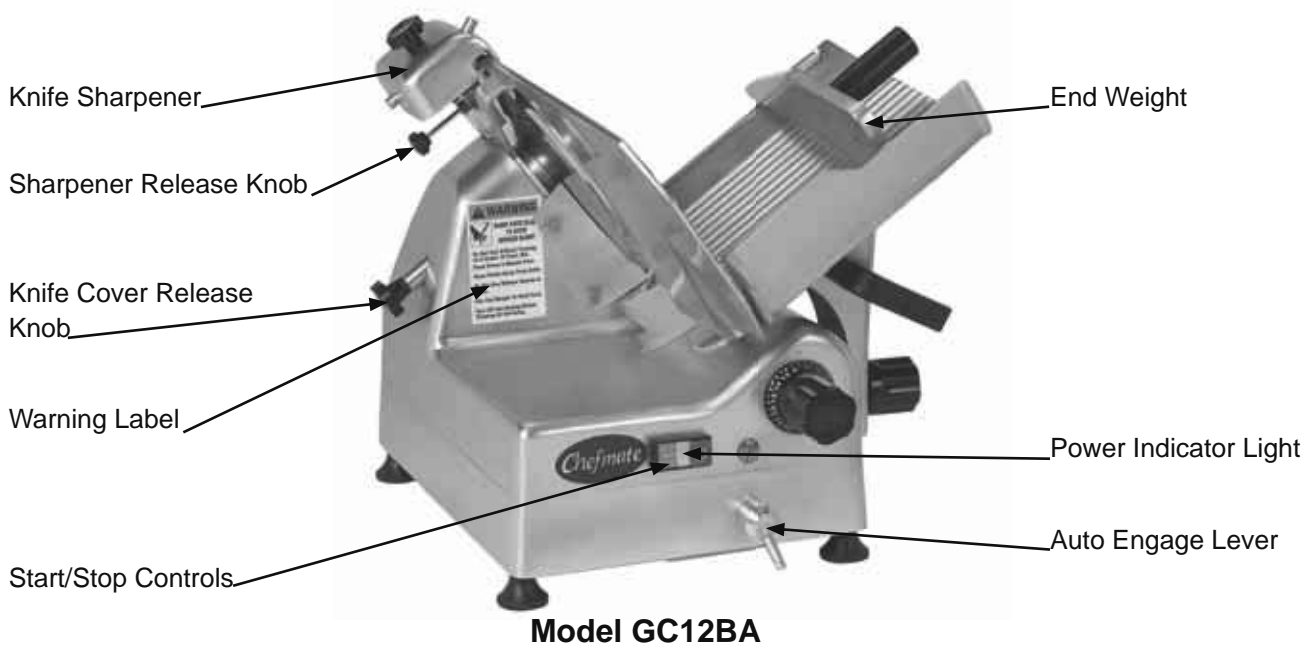
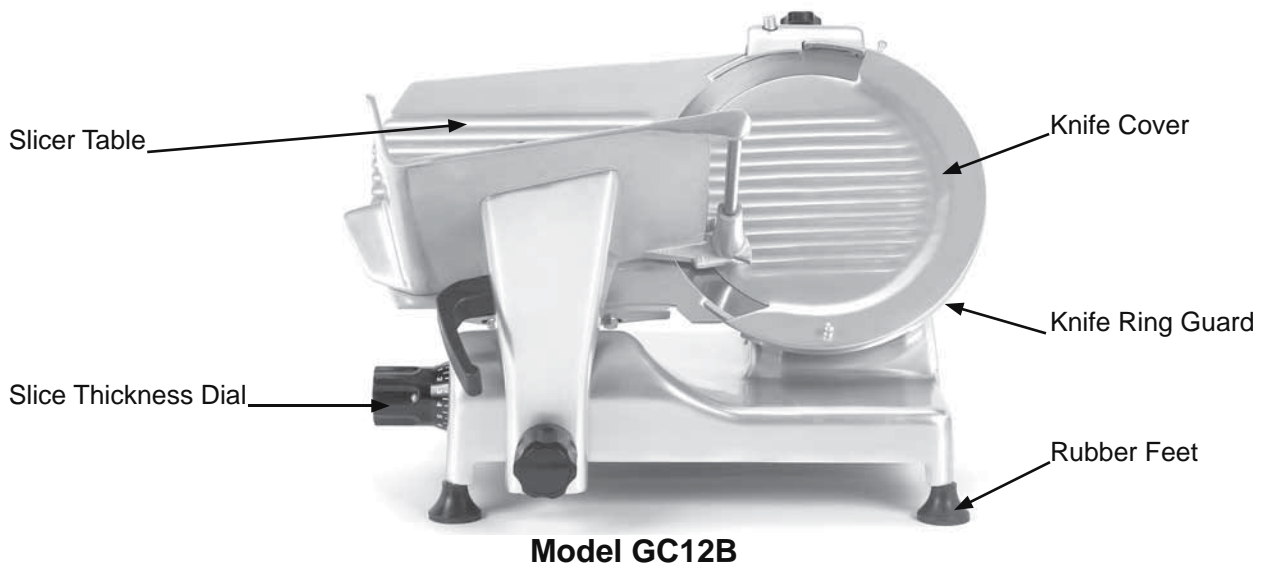
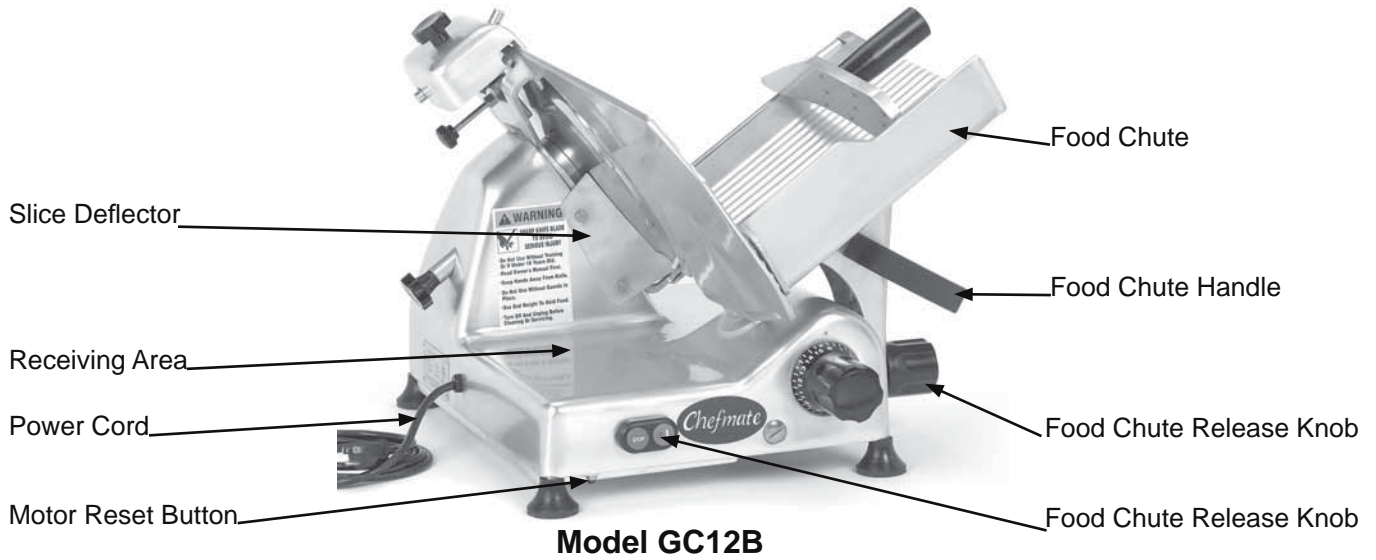

Chefmate Slicer Safety Tips



SHARP KNIFE BLADE

TO AVOID SERIOUS PERSONAL INJURY:

- **NEVER** touch this slicer without training and authorization from your supervisor or if you are under 18 years old. Read this instruction manual first.
- **ONLY** install the slicer on a level nonskid surface that is nonflammable and is located in a clean, well-lighted work area away from children and visitors.
- **ALWAYS** ground slicer utilizing proper power source.
- **NEVER TOUCH KNIFE.** Keep hands and arms away from all moving parts.
- **NEVER OPERATE** slicer without knife cover and knife ring guard securely installed.
- **BEFORE TURNING SLICER ON,** place auto engage lever in "Manual" position (GC12BA only).
- **BE ALERT.** The food chute moves back and forth during automatic operation and can move in either direction on start up (GC12BA only).
- **NEVER** put hand into the chute arm opening on the right side of the slicer.
- **ONLY USE FOOD CHUTE HANDLE** to push the food chute during manual slicing.
- **ONLY USE THE END WEIGHT, NOT YOUR HAND,** to hold food products when slicing. Never put your hand on or around food chute when slicer is on.
- **DO NOT CATCH SLICES WITH YOUR HAND.** Let slices drop onto the receiving area.
- **ALWAYS** turn slicer off, return auto engage lever to "Manual" position (GC12BA only), and turn the slice thickness dial clockwise until it stops after each use.
- **BEFORE CLEANING, SHARPENING, SERVICING, OR REMOVING ANY PARTS,** always turn slicer off, turn the slice thickness dial clockwise until it stops, remove food chute, and unplug power cord.
- **USE ONLY CHEFMATE SLICER ACCESSORIES** properly installed.

Installation

UNPACKING

1. Unpack the slicer immediately after receipt. If the machine is found to be damaged, save the packaging material and contact the carrier within fifteen (15) days of delivery. Immediately contact your source of the equipment. **You have no recourse to damage after fifteen (15) days.**
2. You should receive with the slicer, rubber feet, oil, warranty card, and an instruction manual. Contact Globe or your local supplier if you did not receive all of these materials.



TO AVOID SERIOUS PERSONAL INJURY PROPERLY INSTALL SLICER IN ADEQUATE WORK AREA

- **ALWAYS** install equipment in a work area with adequate light and space.
- **ONLY** operate on a solid, level, nonskid surface that is nonflammable.
- **NEVER** bypass, alter, or modify this equipment in any way from its original condition. Doing so may create hazards and will void warranty.
- **NEVER** operate slicer without the knife cover and knife ring guard securely installed.
- **NEVER** operate slicer without the warning label attached (see page 4 for location).

INSTALLATION:

1. Read this manual thoroughly before installation and operation. **DO NOT** proceed with installation and operation if you have any questions or do not understand anything in the manual. Contact your local representative or Globe **first**.
2. Remove the slicer from the corrugated box.
3. Make sure the rubber feet are firmly tightened.



NEVER USE SLICER WITHOUT RUBBER FEET INSTALLED.

4. Select a location for the slicer that has a level, solid, nonskid surface that is nonflammable and is in a well-lighted work area that is away from children and visitors.



USE AT LEAST TWO PEOPLE TO LIFT THE SLICER UP TO THE OPERATING LOCATION. NEVER ATTEMPT TO LIFT THE SLICER ALONE.

Installation



THIS MACHINE IS PROVIDED WITH A THREE-PRONG GROUNDING PLUG. THE OUTLET TO WHICH THIS PLUG IS CONNECTED MUST BE PROPERLY GROUNDED. IF THE RECEPTACLE IS NOT THE PROPER GROUNDING TYPE, CONTACT AN ELECTRICIAN. DO NOT UNDER ANY CIRCUMSTANCES CUT OR REMOVE THE THIRD GROUND PRONG FROM THE POWER CORD OR USE ANY ADAPTER PLUG (Fig. 7-1 and Fig. 7-2).

5. Inspect the slicer to ensure all parts have been provided.
6. Make sure the knife cover, knife ring guard, and knife sharpener are in place.
7. Make sure the warning label is properly positioned and legible and the instruction manual is available near the slicer.
8. Complete warranty card and mail to Globe or register online at www.globeslicers.com/warranty.asp.
9. Clean the slicer using the procedures outlined in the cleaning section (pages 10 and 11) prior to using the slicer.
10. Contact your local representative or Globe directly if you have any questions or problems with the installation or operation of this slicer.



Figure 7-1 Correct



Figure 7-2 **INCORRECT**

Operating Instructions



SHARP KNIFE BLADE

TO AVOID SERIOUS PERSONAL INJURY:

- **NEVER** touch this slicer without training and authorization from your supervisor or if you are under 18 years old. Read this instruction manual first.
- **NEVER TOUCH KNIFE.** Keep hands and arms away from all moving parts.
- **NEVER OPERATE** slicer without knife cover and knife ring guard securely installed.
- **BEFORE TURNING SLICER ON**, place auto engage lever in "Manual" position (GC12BA only).
- **BE ALERT.** The food chute moves back and forth during automatic operation and can move in either direction on start up (GC12BA only).
- **NEVER** put hand into the chute arm opening on the right side of the slicer.
- **ONLY USE FOOD CHUTE HANDLE** to push the food chute during manual slicing.
- **ONLY USE THE END WEIGHT, NOT YOUR HAND**, to hold food products when slicing. Never put your hand on or around food chute when slicer is on.
- **DO NOT CATCH SLICES WITH YOUR HAND.** Let slices drop onto the receiving area.
- **ALWAYS** turn slicer off, return auto engage lever to "Manual" position (GC12BA only), and turn the slice thickness dial clockwise until it stops after each use.
- **BEFORE CLEANING, SHARPENING, SERVICING, OR REMOVING ANY PARTS**, always turn slicer off, turn the slice thickness dial clockwise until it stops, unplug power cord, and remove food chute.

MANUAL SLICER OPERATION

1. With the slicer turned off, pull the food chute completely towards you and place the food product onto the food chute. When using the GC12BA as a manual slicer make sure to push down or lower the auto engage lever to the "Manual" position and keep it in that position at all times. Slice only boneless, unfrozen product with the slicer. Use the end weight to hold the food product in place.
2. Make sure all knobs are tightened prior to using the slicer.
3. Rotate the slice thickness dial counterclockwise to the desired setting. After slicing is complete, always turn the slice thickness dial clockwise until it stops to close the slicer table.
4. Turn the slicer on by pushing the start button. The power indicator light will illuminate (see page 4 for location).

Operating Instructions

⚠ DO NOT hold the food product with your hand. Never put your hand on or around food chute when slicer is on. The food chute handle is the only part of the slicer you should touch while slicing.

5. Use the food chute handle to manually push the food chute back and forth. The food chute handle is the only part of the slicer you should touch while slicing. Do not catch slices with your hand. Let slices drop onto the receiving area.

⚠ If a product needs to be adjusted during slicing, ALWAYS pull the food chute all the way towards you. Turn off slicer, and close slicer table prior to adjusting the product and the end weight.

6. After the last slice stroke, pull the food chute all the way towards you. Turn the slicer off by pushing the stop button. The power indicator light will go out. Always turn slice thickness dial clockwise until it stops to close the slicer table.
7. Now you can load and unload food product from the food chute.

AUTOMATIC SLICER OPERATION

1. Make sure the slicer is turned off (power indicator light not illuminated). Make sure auto engage lever is in "Manual" position (Fig. 9-1) and the food chute moves freely.
2. Pull the food chute completely towards you and place the food product onto the food chute. Slice only boneless, unfrozen product with the slicer. Swing the end weight into position to secure food product.
3. Rotate the slice thickness dial counterclockwise to the desired setting. After slicing is complete, always turn the slice thickness dial clockwise until it stops to close the slicer table.
4. Press the start button. The power indicator light will illuminate (see page 4 for location).

⚠ BE ALERT. The next step will cause the food chute to move automatically and it can move either direction on start up.

⚠ NEVER attempt to adjust, load or unload food chute when slicer is in automatic operation.

⚠ NEVER put hand into the chute arm opening on the right side of the slicer.

6. To make the food chute move automatically, pull up or raise the auto engage lever into the "Automatic" position (Fig. 9-2).
7. To stop the automatic movement of the food chute, push down or lower the auto engage lever to the "Manual" position.

⚠ The knife is still rotating even though the chute has stopped.

8. To turn the slicer completely off and stop the knife, press the stop button. If the auto engage lever has not already been returned to the "Manual" position, push down or lower the lever to the "Manual" position.



Figure 9-1



Figure 9-2

Cleaning

⚠️ WARNING



SHARP KNIFE BLADE

TO AVOID SERIOUS PERSONAL INJURY:

- **BEFORE CLEANING, SHARPENING, SERVICING, OR REMOVING ANY PARTS**, always turn slicer off, turn the slice thickness dial clockwise until it stops, remove food chute, and unplug power cord.
- **NEVER** attempt to clean slicer with the knife running.
- **NEVER** attempt to remove the knife or knife ring guard from the slicer. They must remain on the slicer for proper operation, sharpening, and cleaning.



The entire slicer, including removable parts, must be thoroughly cleaned and sanitized using the procedures identified by your local health department and the ServSafe Essentials published by the National Restaurant Association Educational Foundation (NRAEF). Visit www.servsafe.com for more details.



It is extremely important to sanitize the slicer and to follow the instructions on your quaternary sanitizer container to ensure proper sanitation is achieved.

⚠️ CAUTION

- **DO NOT** put components in dishwasher.
- **DO NOT** hose down, pressure wash, or pour water on the slicer.
- **NEVER** use a scrubber pad, steel wool, or abrasive material to clean the slicer.
- **DO NOT** use bleach, products containing sodium hypochlorite, or other caustic/strong detergents on the slicer base or removable parts.

Slicer components are easily disassembled without the use of special tools. It may be desirable to wear non-cutting safety gloves during the cleaning operation.

DISASSEMBLY & CLEANING

1. Turn the slicer off, turn the slice thickness dial clockwise until it stops so the table covers the knife's edge, and unplug the power cord.
2. Remove the food chute by rotating the food chute release knob counterclockwise several times. Lift the food chute off the support arm (Fig. 10-1).
3. The slice deflector can be removed by unscrewing the screw knobs (Fig. 10-2).



Figure 10-1



Figure 10-2

Cleaning



BE ALERT. The next steps will expose the knife.

4. Remove the knife cover by rotating the knife cover release knob counterclockwise until it releases (Fig. 11-1). While holding the knobs on the knife cover, carefully lift the knife cover upward to remove.

NOTE: The slicer will not start with the knife cover removed.



Figure 11-1

5. Take the food chute and knife cover back to a three compartment sink. Soak, clean, and scrub the food chute and knife cover using a mild detergent and warm water solution. Following the instructions on your quaternary sanitizer, soak the food chute and knife cover in a proper solution of quaternary sanitizer. **Allow the parts to air dry before reassembling!**



ALWAYS turn slicer off and unplug power cord BEFORE cleaning.

6. To clean the knife, soak a clean cloth in a mild detergent and warm water solution. Ring out excess water from cloth. **Carefully** wash and rinse the top and bottom (underside) of the knife by wiping from the **center of the knife outward** (Fig. 11-2).



Figure 11-2



DO NOT allow moisture to get into knife hub.

7. To clean the knife ring guard, soak a clean cloth in a mild detergent and warm water solution. **Carefully** insert the cloth between the knife and the knife ring guard (Fig. 11-3). While holding the cloth between the knife and the knife ring guard, work it along the entire backside of the knife. A nylon brush could also be used if preferred.
8. To clean the slicer table, soak a clean cloth in a mild detergent and warm water solution. With the slicer table completely closed, wipe the slicer table off by starting at the knife and pulling towards you. Never wipe the slicer table towards the knife.
9. Soak a clean cloth in a mild detergent/warm water solution and finishing cleaning and wiping down the entire slicer.
10. Spray both sides of the knife, slicer table, and the entire slicer with a non-bleach, non-chlorine sanitizer following the instructions on your quaternary sanitizer container to ensure proper sanitation is achieved. **Allow the parts to air dry before reassembling!**



Figure 11-3

REASSEMBLY

1. Carefully reinstall the cleaned, sanitized, and dry knife cover. Hold the knife cover with one hand while securely tightening the knife cover release knob with the other hand.
2. Place the cleaned, sanitized, and dry food chute back onto the chute arm. Tighten the food chute release knob securely to prevent any “play” between the food chute and the chute arm.
3. Plug in power cord.

NOTE: If you wish to remove the knife sharpener for cleaning refer to page 15 for instructions.

Knife Sharpening

WARNING



SHARP KNIFE BLADE

TO AVOID SERIOUS PERSONAL INJURY:

- **NEVER** touch rotating knife.
- **ALWAYS** keep hands clear of all moving parts.
- **ALWAYS** turn slicer off, return the auto engage lever to “Manual” position (GC12BA only), turn slice thickness dial clockwise until it stops, and remove food chute before sharpening.
- **NEVER** sharpen slicer unless all guards are installed.

WHEN AND HOW OFTEN TO SHARPEN THE KNIFE

1. Symptoms of a dull knife are excess waste/or a “tail” on the unsliced portion remaining in the food chute.
2. The knife needs to be sharpened periodically to provide consistent slices and maximum food product yield. Sharpening the knife lightly every few days is more effective than heavy sharpening at less frequent intervals.

PREPARING TO SHARPEN



Make sure auto engage lever is in the “Manual” position (GC12BA only).

1. Turn the slicer off and turn the slice thickness dial clockwise until it stops so the slicer table covers the knife's edge.
2. Remove food chute from the slicer.
3. Clean and dry both sides of the knife before sharpening, following instructions for knife cleaning on pages 10 and 11.

NOTE: The knife cover must be on during sharpening. The slicer will not start if the knife cover is removed.

4. Loosen the sharpener release knob by turning it counterclockwise several times (Fig. 12-1).



BE ALERT. The next step will expose the knife.

5. Lift the sharpener cover up (Fig. 12-1), rotate it clockwise (Fig. 12-2), and lower it into position with the knife fitting between the two stones (Fig. 12-3).
6. Tighten the sharpener release knob (Fig. 12-1) to secure the sharpener.

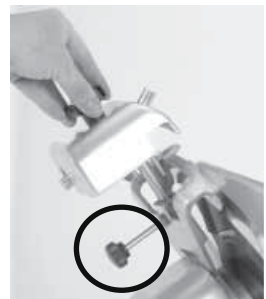

Figure 12-1



Figure 12-2



Figure 12-3

Knife Sharpening

SHARPENING THE KNIFE - (Regular Procedure)

1. Start the slicer.
2. Push the grinding stone button #2 (Fig. 13-1) and the honing stone button #3 (Fig. 13-2) at the same time so both stones make contact with the knife. Maintain pressure on the buttons for 5-10 seconds.



TURN SLICER OFF before inspecting.

SHARPENING THE KNIFE - (Extended Procedure)

NOTE: Use the extended procedure if the regular sharpening procedure does not produce satisfactory results.

1. Start the slicer.
2. Push the grinding stone button #2 (Fig. 13-1) so the stone sharpens the back side of the knife. Maintain pressure on the button for 30 seconds.
3. Push the grinding stone button #2 (Fig. 13-1) and the honing stone button #3 (Fig. 13-2) at the same time so both stones make contact with the knife. Maintain pressure on the buttons for 5 seconds.



TURN SLICER OFF before inspecting.

AFTER SHARPENING

1. Turn the slicer off and unplug the power cord.
2. Loosen the sharpener release knob.
3. Rotate the sharpener and place it back in its stored position (Fig. 13-3).
4. Tighten the sharpener release knob.
5. Clean the entire slicer as described on pages 10 and 11.
6. Reinstall the food chute and plug the power cord in.

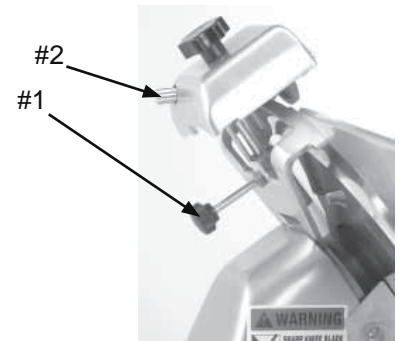

Figure 13-1

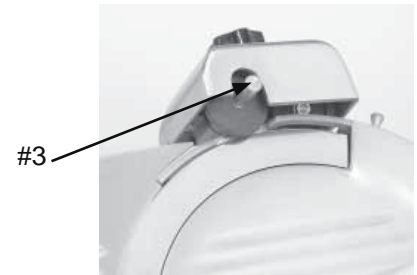

Figure 13-2



Figure 13-3

Simple Maintenance and Repair

⚠ WARNING



SHARP KNIFE BLADE

TO AVOID SERIOUS PERSONAL INJURY:

- **ALWAYS** turn off slicer and unplug slicer before servicing.
- **NEVER** touch this slicer without training and authorization from your supervisor.
- **ALWAYS** keep hands clear of rotating knife and moving parts.
- **DO NOT** tamper with, bypass, or remove any safety devices, guards, or switches.
- **ALWAYS** turn off slicer and turn slice thickness dial completely clockwise after each use.
- **USE ONLY Chefmate** parts and accessories properly installed.

LUBRICATION

Various slicer parts need to be lubricated periodically using Globe oil. Globe oil is a light, tasteless, odorless mineral oil that will not contaminate or impart odors or taste to sliced food products.

⚠ CAUTION

**DO NOT USE VEGETABLE OIL TO LUBRICATE SLICER.
VEGETABLE OIL WILL DAMAGE THE SLICER!**

Food Chute Slide Rod

It is necessary to lubricate the food chute slide rod with Globe oil if the food chute becomes difficult to push.

1. Unplug the slicer and remove the food chute.
2. Tilt the slicer on its end. NOTE: The bottom of the GC12BA is completely covered. Unscrew the four rubber feet to remove the slicer cover.
3. Put several drops of Globe oil on the slide rod (Fig. 14-1) towards the top of the rod.
4. Tilt the slicer back to its normal position.
5. Push the food chute back and forth several times to distribute the oil onto the slide rod.
6. Reinstall the food chute.
7. Plug the slicer in.

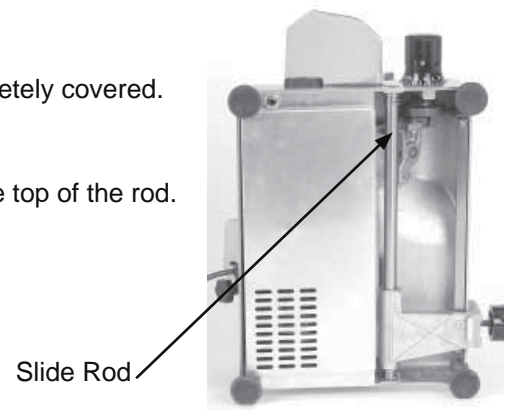

Figure 14-1

Simple Maintenance and Repair

CAUTION

**DO NOT USE VEGETABLE OIL TO LUBRICATE SLICER.
VEGETABLE OIL WILL DAMAGE THE SLICER!**

Sharpener Shafts

It is necessary to lubricate the sharpener shafts with Globe oil weekly.

1. Loosen the sharpener release knob and pull the sharpener up to remove it (Fig. 15-1).
2. Put several drops of Globe oil on the shaft behind each sharpening stone (Fig 15-2).
3. Push both sharpener buttons a couple of times to distribute the oil onto the shafts.
4. Put several drops of Globe oil on the main shaft (Fig. 15-1), place the sharpener back into position and tighten the sharpener release knob.
5. Wipe off any excess oil that drips onto the slicer.

NOTE: The sharpener and stones can be cleaned with warm water and a brush. Allow it to air dry. **If the sharpener or stones are cleaned it is very important that all sharpener shafts are lubricated with Globe oil afterwards!**

End Weight Slide Rod

The end weight slide rod should be lubricated weekly or when excessive drag is felt with a few drops of Globe oil.

1. Apply a few drops of Globe oil to the slide rod (Fig. 15-3).
2. Slide the end weight up and down to distribute the oil.

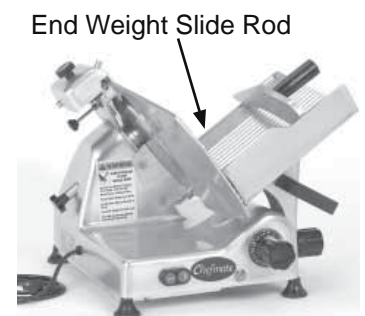
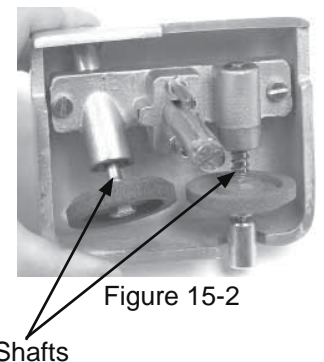
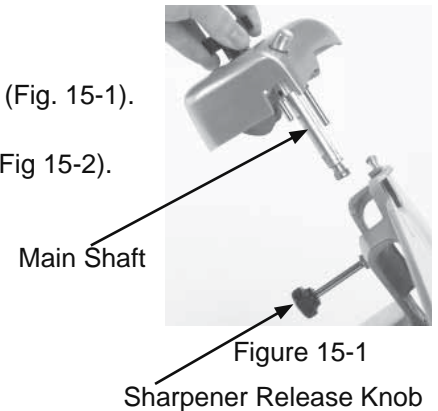

Globe recommends that an authorized Globe service company perform all adjustments and major maintenance.

**By adequately maintaining your slicer,
it will provide years of dependable service.**

Troubleshooting Guide

SYMPTOM	CAUSE	SOLUTION
Slicer will not start	<p>Slicer not plugged in</p> <p>Knife cover removed or not properly installed</p>	<p>Plug in slicer</p> <p>Install knife cover and tighten the knife cover release knob</p>
Ragged cuts-poor yield	<p>Dull knife</p> <p>Chipped knife</p> <p>Knife-slicer table gap too wide</p> <p>Knife too small</p>	<p>Sharpen knife-make sure knife and stones are clean</p> <p>Sharpen or have new knife installed</p> <p>Call for service to adjust slicer table</p> <p>Have new knife installed</p>
Metal rubbing knife	<p>Knife cover</p> <p>Food chute</p> <p>End weight</p> <p>Slicer table</p>	<p>Tighten knife cover release knob</p> <p>Tighten or adjust food chute knob</p> <p>Have defective end weight replaced</p> <p>Call for service to adjust slicer table</p>
Hard to push food chute	No lubrication	Lubricate slide rods thoroughly with Globe oil. No vegetable oil!
Hard to sharpen	<p>Stones dirty, wet or clogged with grease</p> <p>Knife dirty</p> <p>Worn stones</p> <p>Stones not properly aligned</p>	<p>Clean stones with warm water and a brush. Allow stones to air dry. Lubricate shafts with Globe oil afterwards.</p> <p>Clean top and bottom of knife</p> <p>Have stones replaced</p> <p>Have sharpener adjusted</p>
Slicer stops running	Motor overheated	Wait 10-15 minutes for slicer to cool down. Push the reset button, then start the slicer.

Limited Slicer Warranty

Globe Food Equipment Company ("GFE") warrants to the original purchaser of new equipment that said equipment, when installed in accordance with our instructions within North America and subjected to normal use, is free from defects in material or workmanship for a period of 1 year from installation or 18 months from actual shipment date, whichever date occurs first.

THIS WARRANTY IS IN LIEU OF ALL OTHER WARRANTIES, WHETHER EXPRESS OR IMPLIED. GFE EXPRESSLY DISCLAIMS ANY IMPLIED WARRANTY OF MERCHANTABILITY OR EXPRESS OR IMPLIED WARRANTY OF FITNESS FOR A PARTICULAR PURPOSE.

GFE'S OBLIGATION AND LIABILITY UNDER THIS WARRANTY IS EXPRESSLY LIMITED TO REPAIRING AND REPLACING EQUIPMENT WHICH PROVES TO BE DEFECTIVE IN MATERIAL OR WORKMANSHIP WITHIN THE APPLICABLE WARRANTY PERIOD. All repairs pursuant to this Warranty will be performed by an Authorized Designated GFE Service Location during normal working hours. IN NO EVENT SHALL GFE BE LIABLE FOR INCIDENTAL OR CONSEQUENTIAL DAMAGES TO BUYER OR ANY THIRD PARTY, INCLUDING, WITHOUT LIMITATION, LOSS OF PROPERTY, PERSONAL INJURY, LOSS OF BUSINESS OR PROFITS OR OTHER ECONOMIC LOSSES, OR STATUTORY OR EXEMPLARY DAMAGES, WHETHER IN NEGLIGENCE, WARRANTY, STRICT LIABILITY, OR OTHERWISE.

This warranty is given only to the first purchaser from a retail dealer. No warranty is given to subsequent transferees.

This warranty does not cover product failures caused by: failure to maintain, neglect, abuse, damage due to excess water, fire, normal wear, improper set up and use. Periodic maintenance including lubrication and sharpening are not covered.

This warranty is not in force until such time as a properly completed and signed installation/warranty registration or an online registration form has been received by GFE within 30 days from the date of installation. Register online at www.globeslicers.com/warranty.asp.

THE FOREGOING WARRANTY PROVISIONS ARE A COMPLETE AND EXCLUSIVE STATEMENT BETWEEN THE BUYER AND SELLER. GFE NEITHER ASSUMES NOR AUTHORIZES ANY PERSONS TO ASSUME FOR IT ANY OTHER OBLIGATION OR LIABILITY IN CONNECTION WITH SAID EQUIPMENT.

Example of items not covered under warranty, but not limited to just these items:

1. Acts of God, fire, water damage, burglary, accident, theft, vandalism.
2. Freight damage.
3. Improper installation or alteration of equipment.
4. Use of generic or after market parts.
5. Repairs made by anyone other than a GFE designated servicer.
6. Lubrication.
7. Expendable wear parts, knife, stones, rubber boots, blown fuses, lamps.
8. Cleaning of equipment.
9. Misuse or abuse.