

Parts Catalog



Model GC12B

SLICING MACHINES

MODELS: GC12B and GC12BA

8-24-10

IMPORTANT!

TO EXPEDITE SHIPMENT OF PARTS, ALWAYS SPECIFY MODEL, REV,
PART NUMBER, AND SERIAL NUMBER OF SLICER.

GLOBE FOOD EQUIPMENT COMPANY

2215 East River Road
Dayton, Ohio 45439

Parts Department

Toll Free 1-800-745-6238 • Fax (937) 290-0585

E-Mail: globeinfo@globeslicers.com

Website: www.globeslicers.com

Not for resale

TABLE OF CONTENTS

<u>BASE</u>	<u>1 - 2</u>
<u>CHUTE COMPONENTS AND ELECTRICAL</u>	<u>3 - 4</u>
<u>AUTO DRIVE COMPONENTS</u>	<u>5 - 6</u>
<u>KNIFE & SHARPENER COMPONENTS</u>	<u>7 - 8</u>
<u>SCHEMATICS</u>	<u>9</u>

SLICER BASE

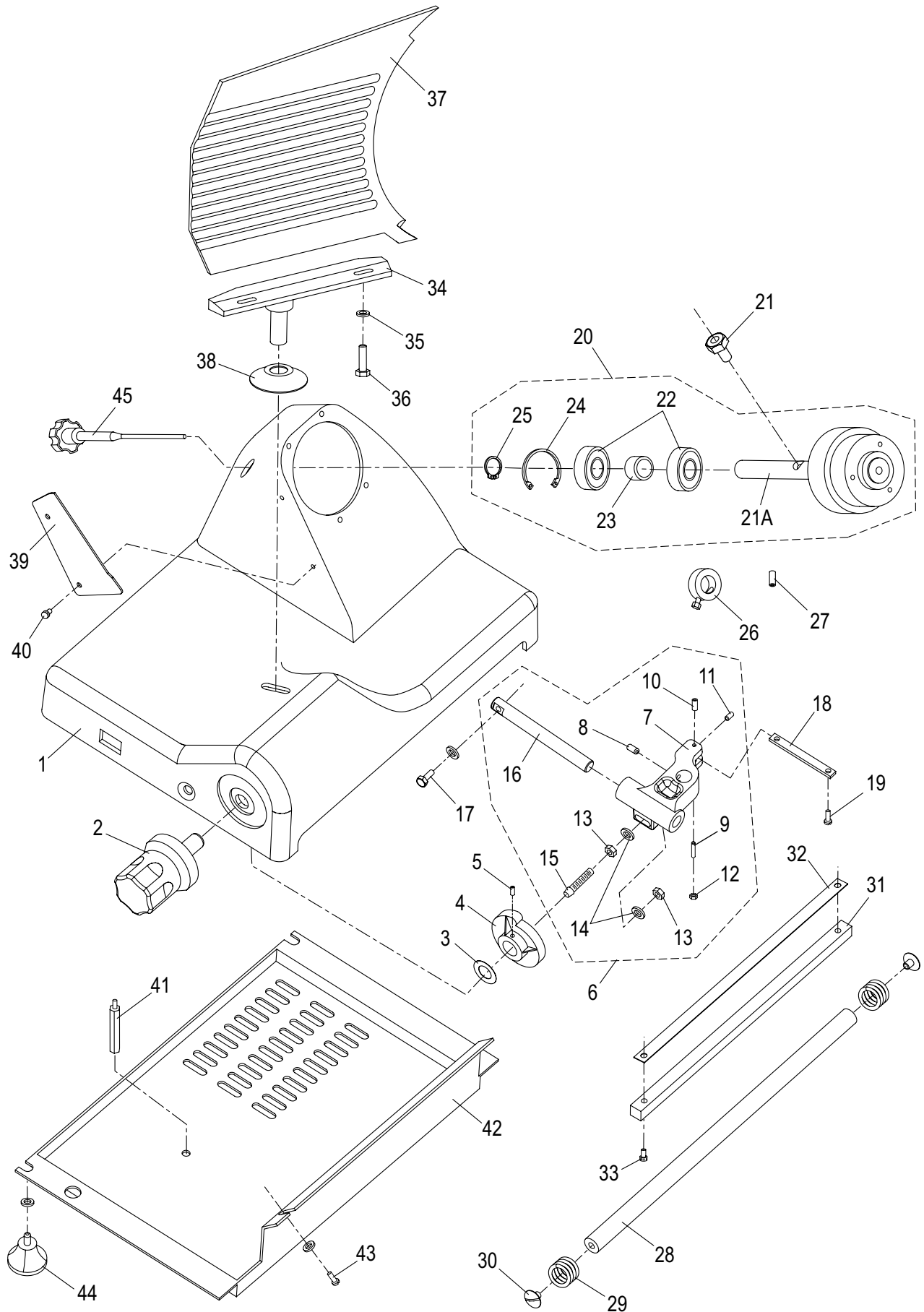

SLICER BASE PARTS LIST

ITEM	PART DESCRIPTION	PART NUMBER	QTY
1	SLICER BASE	-	1
2	KNOB, TABLE ADJUSTING	M002	1
3	WAVE WASHER	M003	1
4	CAM, TABLE ADJUSTING (WITH SET SCREWS)	M004	1
5	SET SCREW, TABLE ADJUSTING CAM	M5x10mm Flat Pt	2
6	TABLE SLIDE ASSY	M305	1
7	TABLE SLIDE	M005	1
8	SET SCREW	M8 x 10mm	2
9	STUD, THREADED	M5 x 20mm	1
10	STUD, THREADED	M5 x 10mm	1
11	SET SCREW	M4 x 6mm Cup Pt	1
12	NUT	5MA	1
13	NUT	D8MA	2
14	FLAT WASHER	D8	2
15	STUD, CAM ACTUATOR	M013	1
16	SHAFT, TABLE SLIDE	M014	1
17	SCREW & FLAT WASHER	M015	1
18	PLATE, TABLE SLIDE	M016	1
19	SCREW	M017	1
20	KNIFE HUB ASSY (MICROSWITCH MTG BOLT)	M319	1
	†KNIFE HUB ASSEMBLY (COLLAR, ITEM 26)	-	
21	MICROSWITCH MOUNTING BOLT	MCR61	1
22	BEARING	M020	2
23	BUSHING	M021	1
24	RETAINING RING, INTERNAL	47mm DIN 472	1
25	RETAINING RING, EXTERNAL	20mm DIN 471	1
26	†SHAFT COLLAR, KNIFE HUB (M5 X 10 SCREW)	M025	1
27	SET SCREW, HUB SHAFT MOUNTING	M027	2
28	SLIDE ROD, ROUND	M059	1
29	SPRING, SLIDE ROD - ROUND	M061	2
30	SCREW, SLIDE ROD	M060	2
31	SLIDE BAR, SQUARE	M062	1
32	WEAR STRIP, SLIDE BAR - SQUARE	M063	1
33	SCREW	M064	2
34	TABLE SUPPORT	MANUAL	1
	TABLE SUPPORT	AUTO	
35	FLAT WASHER	M071	2
36	SCREW	M070	2
37	TABLE	M072	1
38	COVER, HOLE - BASE	M073	1
39	SLICE DEFLECTOR	M097	1
40	SCREW, SLICE DEFLECTOR MOUNTING	M098	2
*41	STANDOFF	M043	1
*42	BOTTOM COVER	M113	1
*43	SCREW, BOTTOM COVER - W/FLAT WASHER	M114	2
*44	FOOT W/FLAT WASHER	M115	4
45	KNOB, COVER RELEASE	M050	1
46	LABEL, WARNING (NOT SHOWN)	81	1
47	LABEL, CHEFMATE (NOT SHOWN)	83	1

* MANUAL SLICER ONLY (GC12B).

†PARTS OBSOLETE. REPLACE WITH M319 KNIFE HUB ASSY W/MOUNTING BOLT.

CHUTE AND ELECTRICAL COMPONENTS

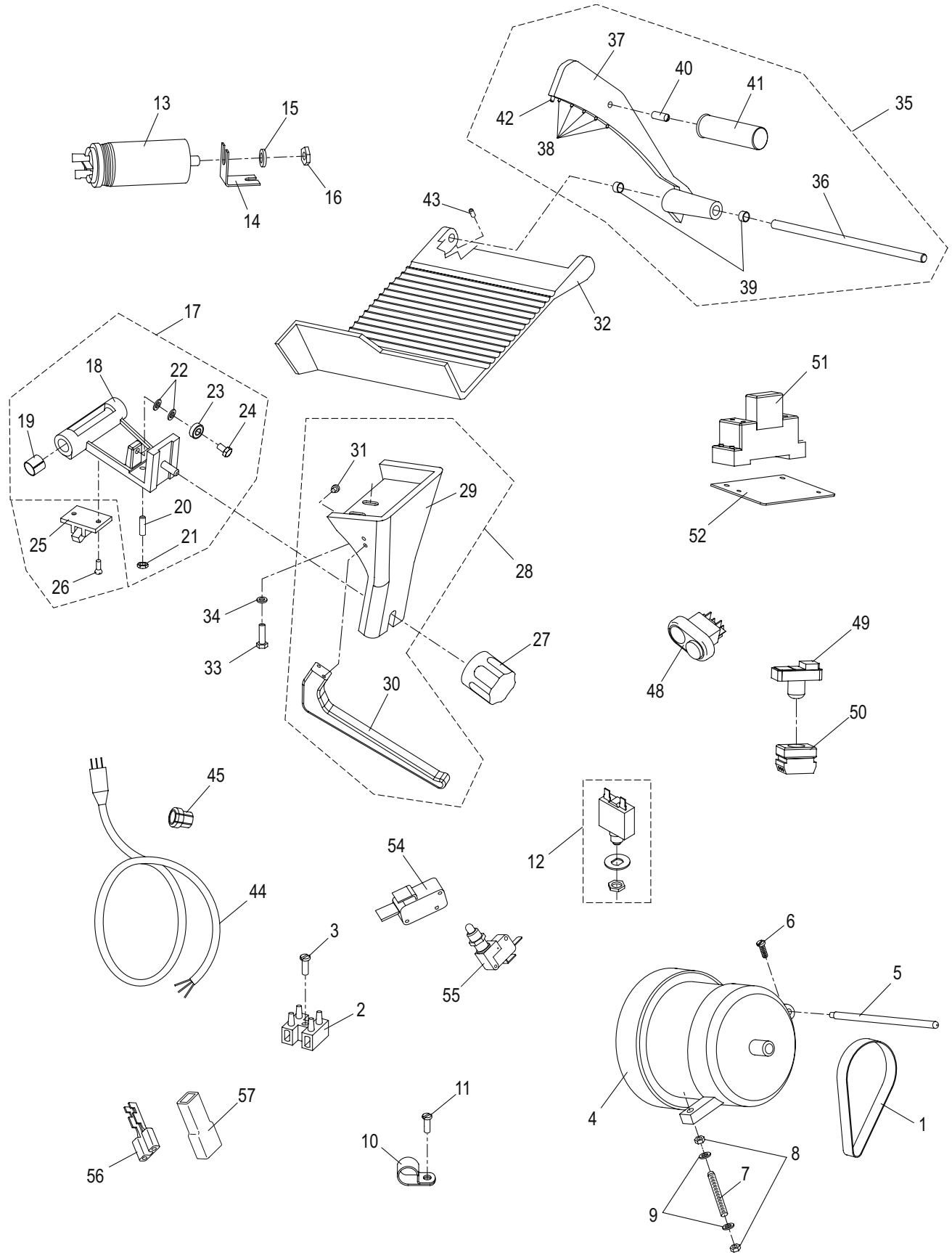

CHUTE AND ELECTRICAL COMPONENTS PARTS LIST

ITEM	PART DESCRIPTION	PART NUMBER	QUANTITY	
			MAN	AUTO
1	DRIVE BELT	M024	1	
2	TERMINAL BLOCK	M028	1	
3	SCREW	M029	1	
4	KNIFE MOTOR	M030	1	
5	PIN, MOTOR PIVOT	M031	1	
6	SCREW	M032	1	
7	STUD	M033	1	
8	NUT	M034	2	
9	FLAT WASHER	M035	2	
10	CABLE CLAMP	M037	1	
11	SCREW, CABLE CLAMP MOUNTING	M5x10mm	1	
12	SWITCH, MOTOR RESET	M038	1	
13	CAPACITOR, 16 μ f	M039	1	2
14	BRACKET, CAPACITOR MOUNTING	M042	1	2
15	WASHER	M040	1	2
16	NUT	M041	1	2
17	CHUTE SLIDE ASSEMBLY	M352	1	-
		M352BA	-	1
18	CHUTE SLIDE	-	1	1
19	BUSHING, CHUTE SLIDE ASSEMBLY	M057	2	
20	STUD	M053	1	
21	NUT	M8	1	
22	FLAT WASHER	M055	2	
23	BEARING	M056	1	
24	SCREW	M058	1	
25	CHUTE SLIDE COUPLING	M143	-	1
26	SCREW, FLAT HEAD	M5 X 15mm	-	2
27	KNOB, CHUTE SUPPORT	M065	1	
28	CHUTE SUPPORT ASSEMBLY	M066	1	
29	CHUTE SUPPORT	M066-1	1	
30	HANDLE, CHUTE SUPPORT	M067	1	
31	SCREW, HANDLE MOUNTING	M068	2	
32	CHUTE	M099	1	
33	SCREW, CHUTE MOUNTING	M100	2	
34	FLAT WASHER, CHUTE MOUNTING	M101	2	
35	END WEIGHT ASSEMBLY	MC014	1	-
		M103BA	-	1
36	END WEIGHT ROD	M102	1	
37	END WEIGHT	-	1	1
38	END WEIGHT PRONG	-	5	7
39	BUSHING, END WEIGHT	M105	2	
40	STUD, END WEIGHT HANDLE	M106	1	
41	HANDLE, END WEIGHT	M107	1	
42	END WEIGHT BUMPER	M108	1	
43	SET SCREW, END WEIGHT ROD	M109	1	
44	POWER CORD	M110	1	
45	STRAIN RELIEF	M111	1	
46	SCREW, GRND (NOT SHOWN)	M5 x 6mm	1	
47	LOCK WASHER (NOT SHOWN)	M5	1	
48	POWER SWITCH, MANUAL SLICER	M036	1	-
49	POWER SWITCH, AUTO SLICER	MCB58	-	1
50	BODY, POWER SWITCH	M142	-	1
51	RELAY	M140	-	1
52	PLATE, RELAY MOUNTING	M149	-	1
53	SCREW, PLATE MOUNTING -PAN HD	M5 x 15mm	-	2
54	MICROSWITCH, CHUTE DRIVE	M139	-	1
55	MICROSWITCH, INTERLOCK	M026	M026	1
56	SCREW, MICROSWITCH MTG - PAN HD	M3 x 15mm	-	2
57	TERMINAL, FEMALE	-	-	4
58	HOUSING, TERMINAL	-	-	4

AUTO DRIVE COMPONENTS

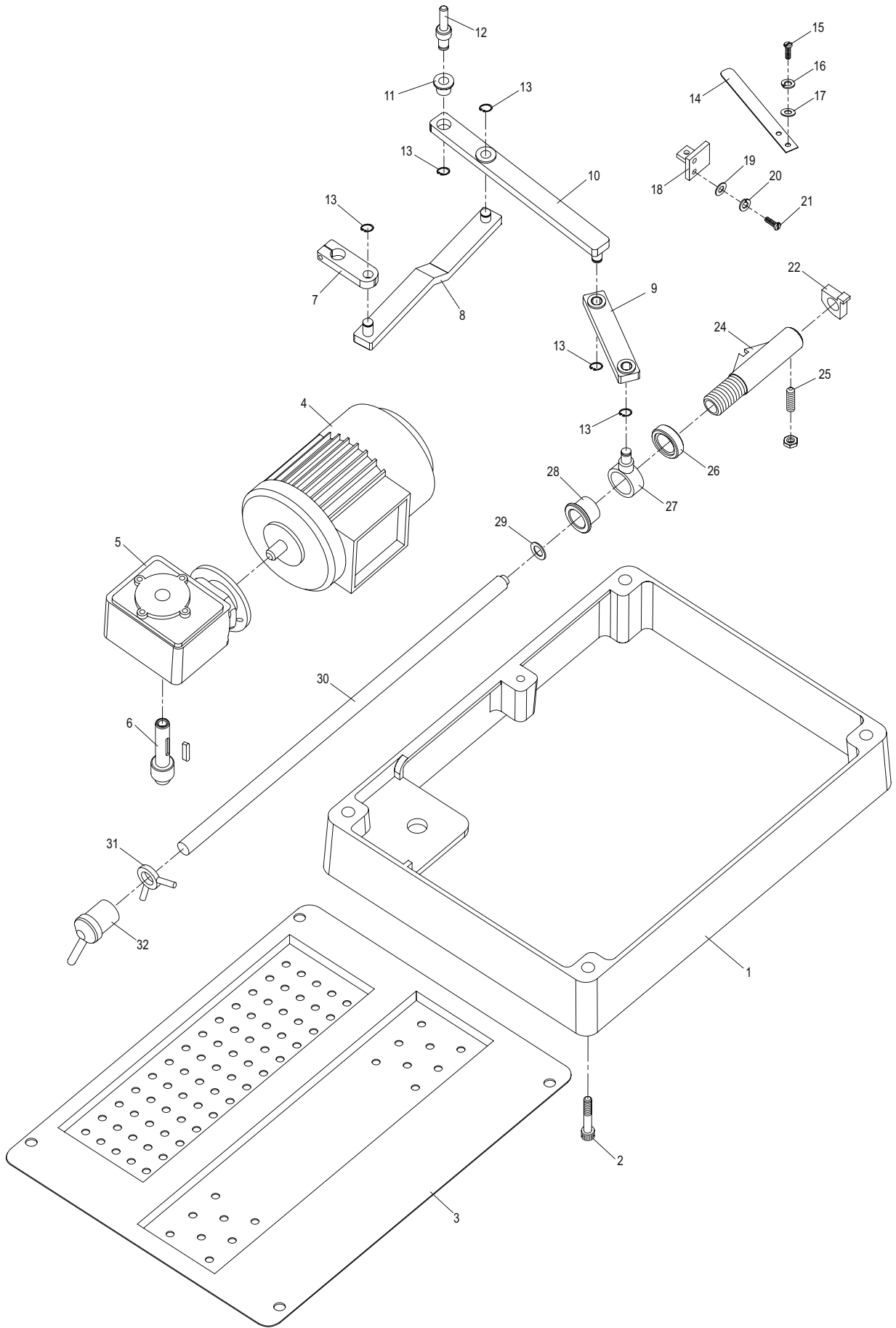

AUTO DRIVE PARTS LIST

ITEM	NO.	DESCRIPTION	QTY
1	M118 BA	APRON	1
2	M148	SCREW, APRON MOUNTING	4
3	M119 BA	BOTTOM COVER	1
4	M120	CHUTE MOTOR	1
5	M121	REDUCING GEAR	1
6	M129	AUTO DRIVE SHAFT	1
7	M130	AUTO DRIVE COUPLING	1
8	M131	CONNECTING ROD A	1
9	M132	CONNECTING ROD B	1
10	M133	CONNECTING ROD C	1
11	M137	BUSHING	5
12	M144	PIVOT	1
13	M146	RETAINING RING	5
14	M134	ENGAGEMENT SPRING	1
15	M035	FLAT WASHER	2
16	M5	LOCKWASHER	2
17	M017	SCREW, ENGAGEMENT SPRING MTG	2
18	M135	MTG BRACKET, ENGAGEMENT SPRING	1
19	M035	FLAT WASHER	2
20	M5	LOCKWASHER	2
21	M5-0.8 x 15mm PHMS	SCREW, E SPRING BRKT MOUNTING	2
22	M136	CAM	1
23	-	SETSCREW, CAM (NOT SHOWN)	1
24	M122	CHUTE SLIDE TUBE	1
25	M126	CHUTE SLIDE STUD	1
26	M123	CHUTE SLIDE NUT	1
27	M124	SLIDE ACTUATOR RING	1
28	M125	CHUTE SLIDE BUSHING	1
29	M145	WASHER	1
30	M127	CHUTE SLIDE ROD	1
31	M147	STOP RING	1
32	M128	AUTO ENGAGE LEVER	1

KNIFE COMPONENTS AND SHARPENER

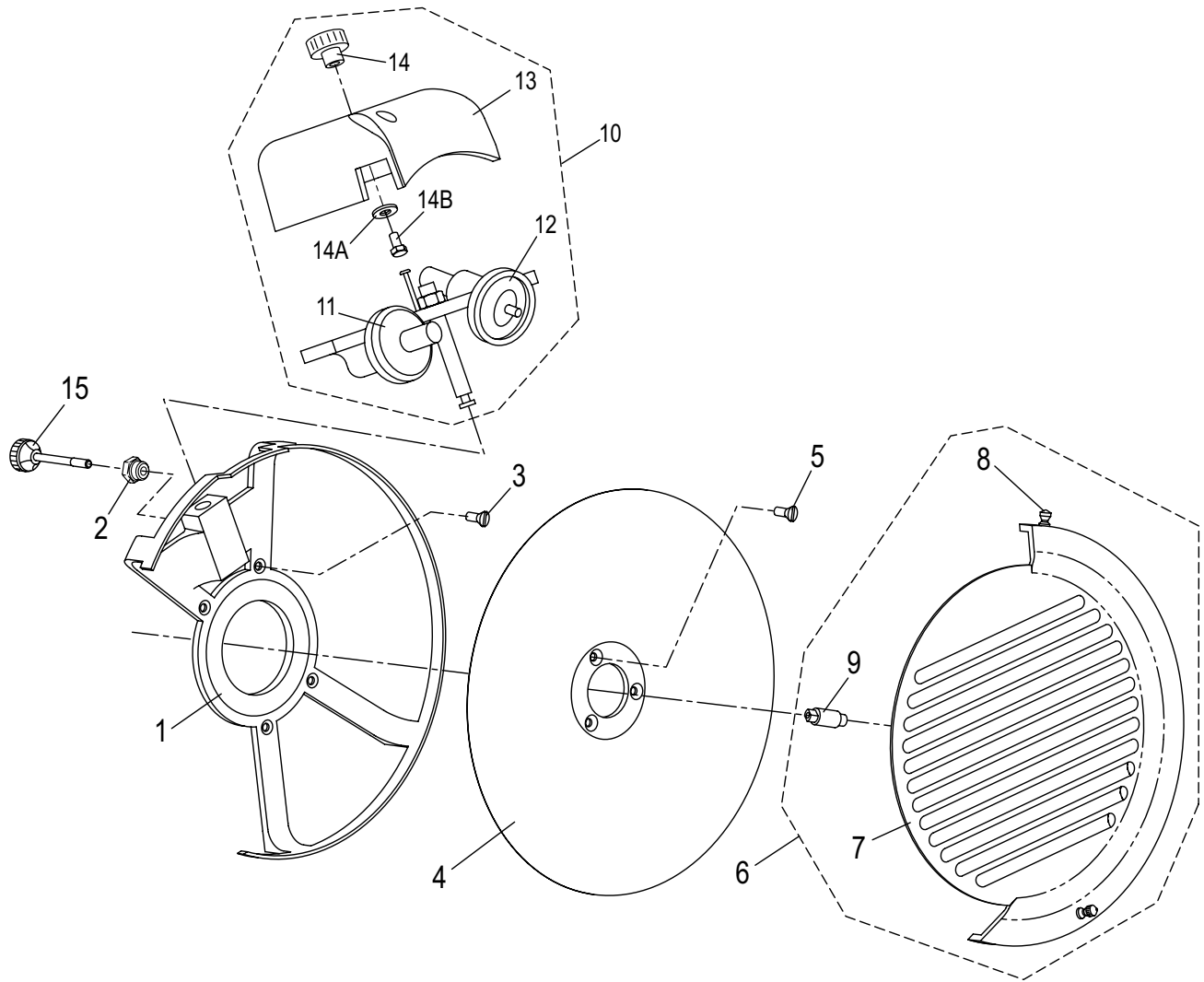

ITEM	PART DESCRIPTION	PART NUMBER	QTY
1	KNIFE RING GUARD	M044	1
2	STUD, KNIFE RING GUARD	M045	1
3	SCREW, KNIFE MOUNTING	M4 x 7mm	4
4	KNIFE	M047	1
5	SCREW, KNIFE MOUNTING	M5 x 12mm	3
6	KNIFE COVER ASSEMBLY	M349	1
7	KNIFE COVER	-	1
8	HANDLE , KNIFE COVER	M051	2
9	STUD, KNIFE COVER	M049A	1
10	KNIFE SHARPENER ASSEMBLY	M377	1
11	SHARPENING STONE	M091	1
12	TRUING STONE	M092	1
13	COVER, SHARPENER	M074	1
14	KNOB, SHARPENER COVER	M075	1
14A	SCREW, KNOB MOUNTING	M6 x 15mm	1
14B	FLAT WASHER	D6	1
15	KNOB, KNIFE SHARPENER ADJUSTMENT	M096	1

WIRING DIAGRAMS - 115V, 50/60Hz, 1PH

