

Parts Catalog



PF32E

Electric Fryer

Model: PF32E

03/22/2019 Rev A

IMPORTANT!

TO EXPEDITE SHIPMENT OF PARTS, ALWAYS SPECIFY MODEL, REV,
PART NUMBER, AND SERIAL NUMBER OF UNIT.

GLOBE FOOD EQUIPMENT COMPANY

2215 East River Road

Dayton, Ohio 45439

Parts Department

Toll Free 1-800-745-6238 · Fax (937) 290-0585

E-Mail: info@globefoodequip.com

Website: www.globefoodequip.com

Not for resale

Table of Contents

Description

Page

PF32E Electric Fryer

4

PF32E Wiring Diagram

6



PF32E Electric Fryer

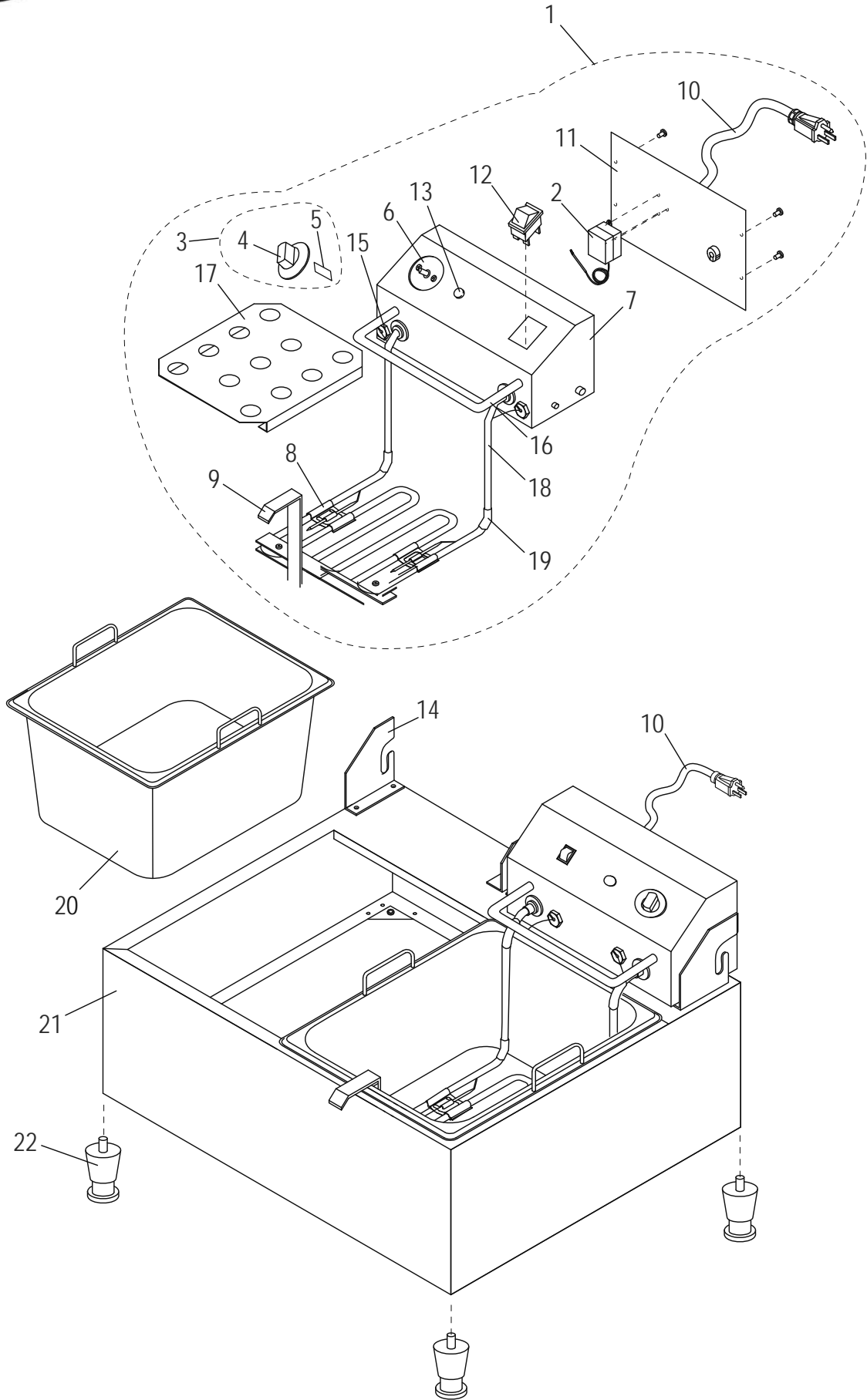



PF32E Electric Fryer

Item	Part Number	Description	Qty	Serial Number
1	U06051470592	Control Box Assembly (Back Hook)	Left Side	1
1	U06051471100	Control Box Assembly (Front Hook)	Left Side	1
1	U06051470593	Control Box Assembly (Back Hook)	Right Side	1
1	U06051471101	Control Box Assembly (Front Hook)	Right Side	1
2	U00577	Thermal Cut Out		2
3	U01033	Knob Assembly		2
4		Dial		2
5		Spring Plate		2
6	U03051220008	Thermostat		2
7		Control Enclosure	Right Side	1
7		Control Enclosure	Left Side	1
8	U01051025117	Tube Clamp		4
9	U00584	Element Handle Assembly		2
10	U03021205013	Power Cord and Plug		2
11		Back Cover Plate		2
12	U03041215027	Power Switch		2
13	U03091240006	Indicator Light		2
14	U00765	Flange Assembly (Right)		2
14	U01051025556	Flange Assembly (Left)		2
15	U01021005017	Stuffing Nut		4
16		Basket Hook		1
17	U01051025555	Element Cover		2
18	U03061225047	Heating Element		2
19	U01051025128	Tube Bend Clamp		4
20	U01121063016	Pan (Retractable Handles)	Used w/Back Hook Baskets	2
20	U06051471081	Pan (Fixed Handles)	Used w/Front Hook Baskets	2
20	U01121063044	Pan (Retractable Handles)	Used w/Front Hook Baskets	2
21		Fryer Cabinet		1
22	U01021005002	Foot		4
23	U02054	Overlay	(Not Shown)	1



PF32E Wiring Diagram

