

# Parts Catalog



**SCR12**

## **Slicing Machine Serial Number 802948 and Up Model: SCR12**

12/18/17 Rev C

**IMPORTANT!**

TO EXPEDITE SHIPMENT OF PARTS, ALWAYS SPECIFY MODEL, REV,  
PART NUMBER, AND SERIAL NUMBER OF UNIT.

### **GLOBE FOOD EQUIPMENT COMPANY**

2215 East River Road  
Dayton, Ohio 45439

#### **Parts Department**

Toll Free 1-800-745-6238 · Fax (937) 290-0585

E-Mail: [info@globefoodequip.com](mailto:info@globefoodequip.com)

Website: [www.globefoodequip.com](http://www.globefoodequip.com)

Not for resale



# Table of Contents

Description	Page
SCR12 Base Components	4
SCR12 Chute Components	6
SCR12 Knife and Sharpener Components	8
SCR12 Electrical Components	10
SCR12 Wiring Diagram - 115V, 50_60Hz, 1PH	12

# SCR12 Base Components

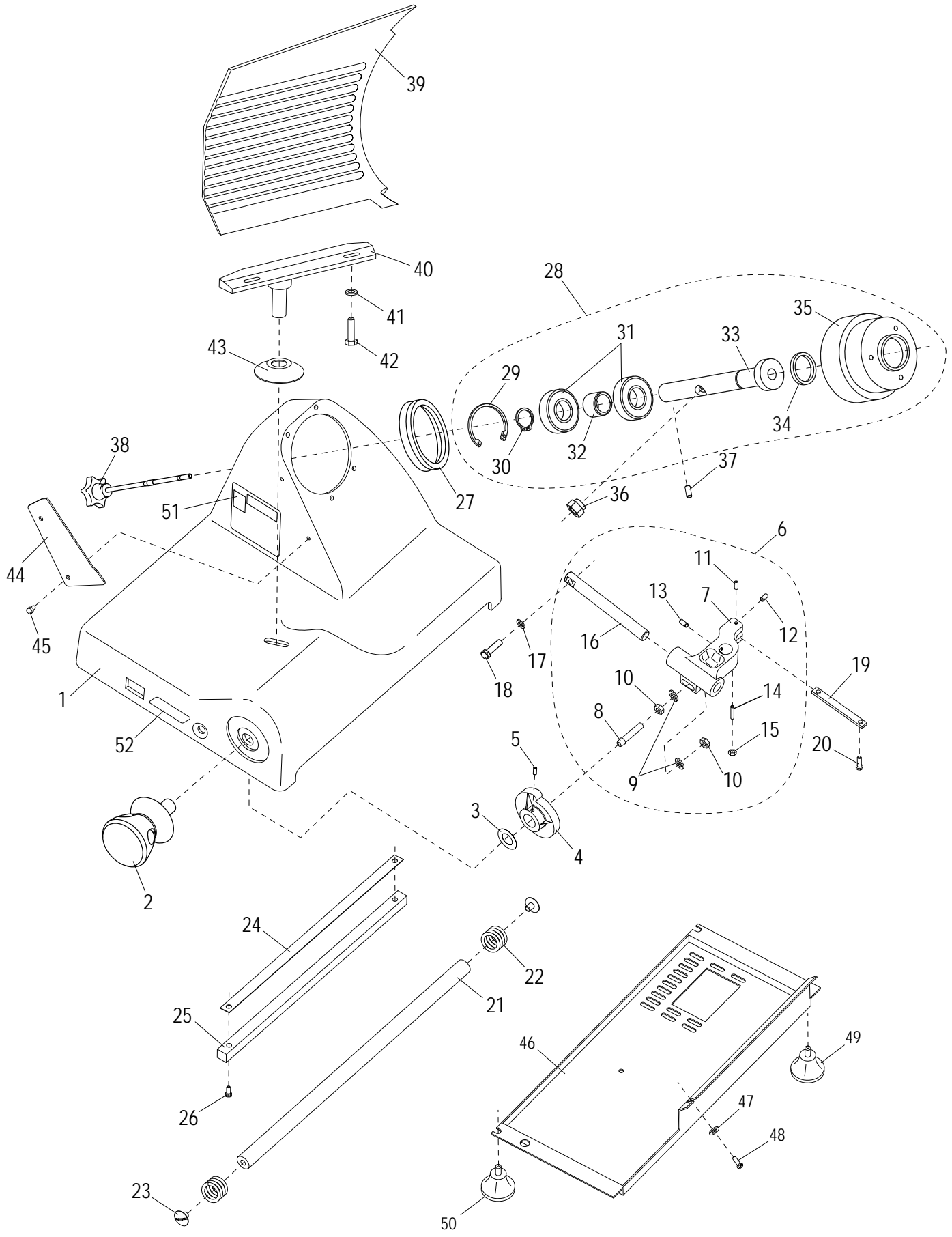



## SCR12 Base Components

Item	Part Number	Description	Qty	Serial Number
1		Slicer Base	1	
2	M00207	Table Adjustment Knob	1	
3	M003	Wave Washer	1	
4	M004	Table Adjustment Cam	1	
5	H00181	Set Screw	2	
6	M305	Table Slide Assy (Incl. items 8-17)	1	
7		Table Slide	1	
8	M013	Stud, Cam Actuator	1	
9	H00191	Flat Washer M8, 8.4 IDx16 ODx1.4-1.8mm thick DIN 125 - Zn	2	
10	H00192	Hex Nut M8-1.25, 13mm Width, 4 mm Height-Zn	2	
11	H00182	Set Screw M5x10 Flat Pt Slotted - Zn	1	
12	H00185	Set Screw, Table Slide End	1	
13	H00186	Set Screw M8-1.25x10 Cup Pt. Hex Socket - BO	2	
14	H00188	Set Screw, Table Slide Bottom	1	
15	H00028	Hex Nut M5 - Zn	1	
16	MR36	Table Slide Rod	1	
17	H00191	Flat Washer M8, 8.4 IDx16 ODx1.4-1.8mm thick DIN 125 - Zn	2	
18	H00116	Hex Head Screw M6-1.0x20 - Zn	2	
19	M016	Table Slide Plate	1	
20	H00061	Hex Head Screw M5x10, Zinc	2	
21	M059	Carriage Slide Rod	1	
22	M061	Carriage Spring	2	
23	M060	Slide Rod Screw	2	
24	M063	Wear Strip, Slide Bar	1	
25	M062	Slide Bar, Square	1	
26	H00056	Slide Bar Screw	2	
27	MGI77/5	V Ring, Knife Seal VA 80	1	
28	M319	Knife Hub Assembly (Incl. items 30-36)	1	
29		Retaining Ring, Internal	1	
30		Retaining Ring, External	1	
31		Bearing	2	
32		Spacer, Knife Pulley	1	
33		Shaft, Knife Hub	1	
34		Oil Seal, Hub	1	
35		Pulley, Knife Hub	1	
36	MCR61	Microswitch Mounting Bolt	1	
37	H00184	Knife Shaft Set Screw	2	
38	M00223	Knife Cover Release Knob	1	
39	M00232	Table	1	
40	M00227	Table Support	1	
41	H00191	Flat Washer M8, 8.4 IDx16 ODx1.4-1.8mm thick DIN 125 - Zn	2	
42	H00196	Table Support Screw	2	
43	M00228	Hole Cover, Base	1	
44	M097	Knife Wiper	1	
45	MCC23	Thumb Screw	2	
46	M113	Bottom Cover	1	
47	H00063	Flat Washer, M5, Zinc	1	
48	H00061	Hex Head Screw M5x10, Zinc	1	
49	M115B	Slicer 1.25" with M8 x 1.25 stud, Back Foot	2	802948 ->
49	M115B	Slicer 1.25" with M8 x 1.25 stud, Back Foot	4	->802947
50	M00769	Slicer 1.5" with M6 x 1.00 stud, Front Foot	2	802948 ->
51	M91022	Label, Warning	1	
52	M91025	Label, Sir Lawrence Logo	1	

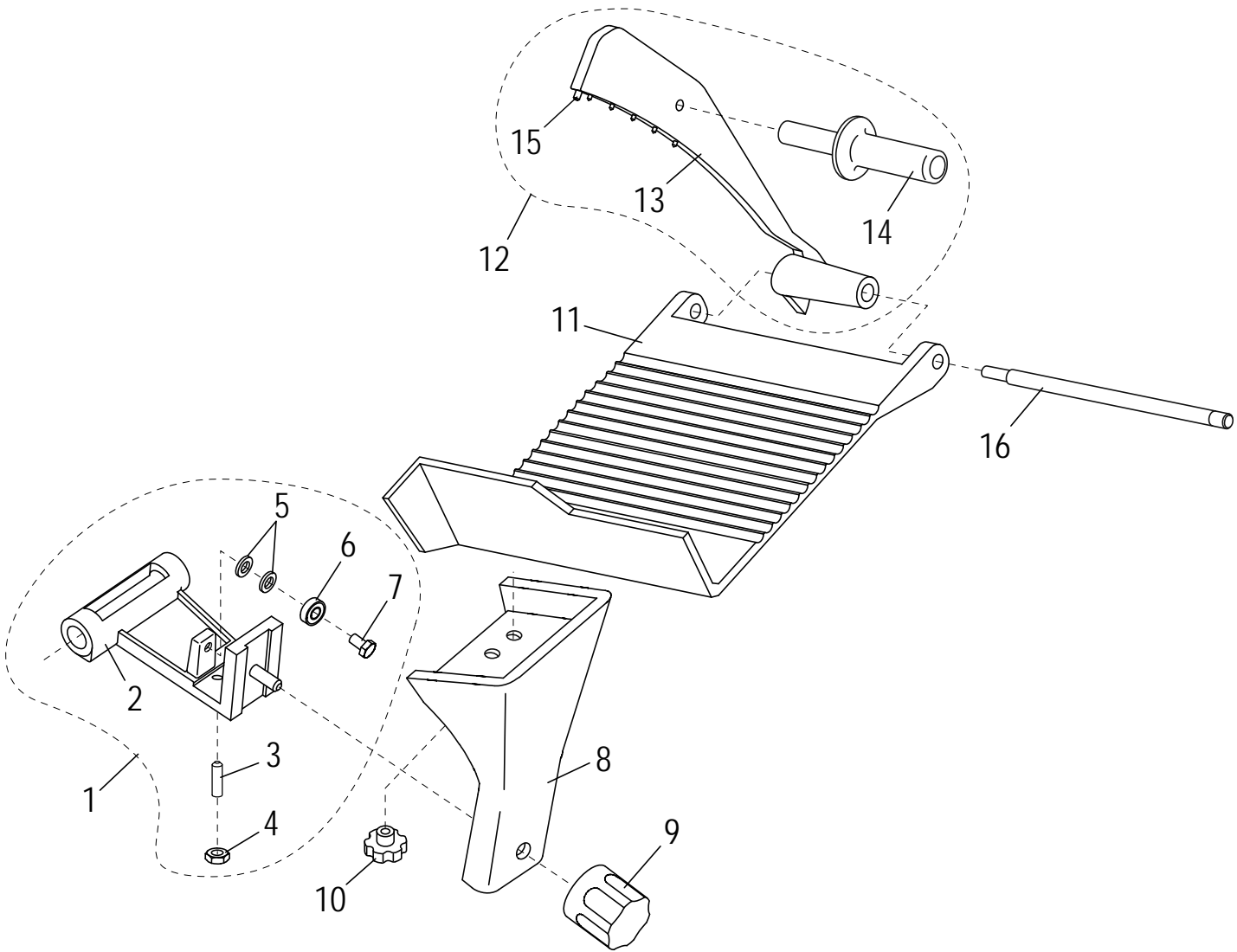



## SCR12 Base Components

Item	Part Number	Description	Qty	Serial Number
1	M352	Chute Slide Assy (Incl. items 2-7)	1	
2		Chute Slide	1	
3	M053	Brass Stud	1	
4	H00192	Hex Nut M8-1.25, 13mm Width, 4 mm Height-Zn	1	
5	H00191	Flat Washer M8, 8.4 IDx16 ODx1.4-1.8mm thick DIN 125 - Zn	2	
6	M056	Bearing	1	
7	H00117	Hex Head Screw M8x20 - Zn	1	
8	M01999	Support, Chute	1	
9	M00285	Chute Support Knob	1	
10	M00367	Chute Release Knob	1	
11	*M01068	Chute	1	806150 ->
11	M00386	Chute	1	
12	M00389	End Weight Assembly (Incl. items 13-15)	1	
12	M01069	End Weight Assembly (Incl. items 13-15)	1	806150 ->
13		End Weight	1	
14	M00372	End Weight Handle	1	
15	M01070	End Weight Bumper	1	806150 ->
15	MC39	Bumper, End Weight	1	
16	M00283	End Weight Rod	1	
16	M01071	End Weight Rod	1	806150 ->

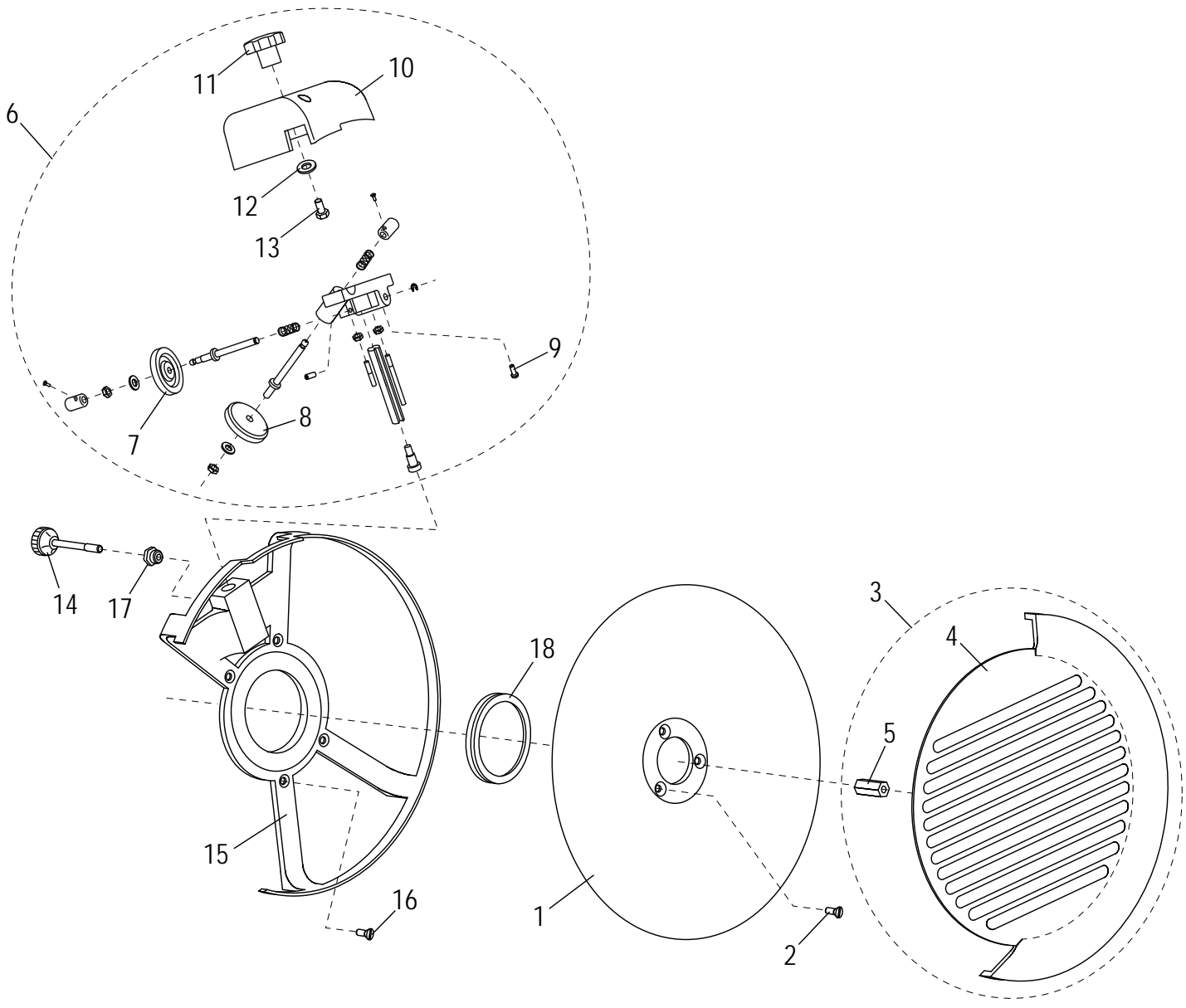





## SCR12 Base Components

Item	Part Number	Description	Qty	Serial Number
1	M047	Knife	1	
2	H00201	Screw, Knife Mounting	3	
3	M349	Knife Cover (Incls. items 4-5)	1	
4		Knife Cover	1	
5	M049A	Knife Cover Insert	1	
6	M01358	Sharpener Assembly (Incls. items 7-13)	1	
7	M092	Deburring Stone	1	
8	MCC17	Sharpening Stone	1	
9	H00187	Cheese Hd Screw M5-0.8x16 Slotted - Zn	2	
10	M074	Sharpener Cover	1	
11	M075B	Sharpener Cover Knob	1	
12	H00014	Flat M6 Washer - Zn	1	
13	H00197	Hex Hd Screw M6x15 - Zn	1	
14	M096B	Sharpener Release Knob	1	
15	M044	Knife Rim Guard	1	
16	H00435	Screw, Rim Guard	4	
17	M045	Insert, Knife Rim Guard	1	
18	M00405	Knife Seal, V Ring - VA 80	1	

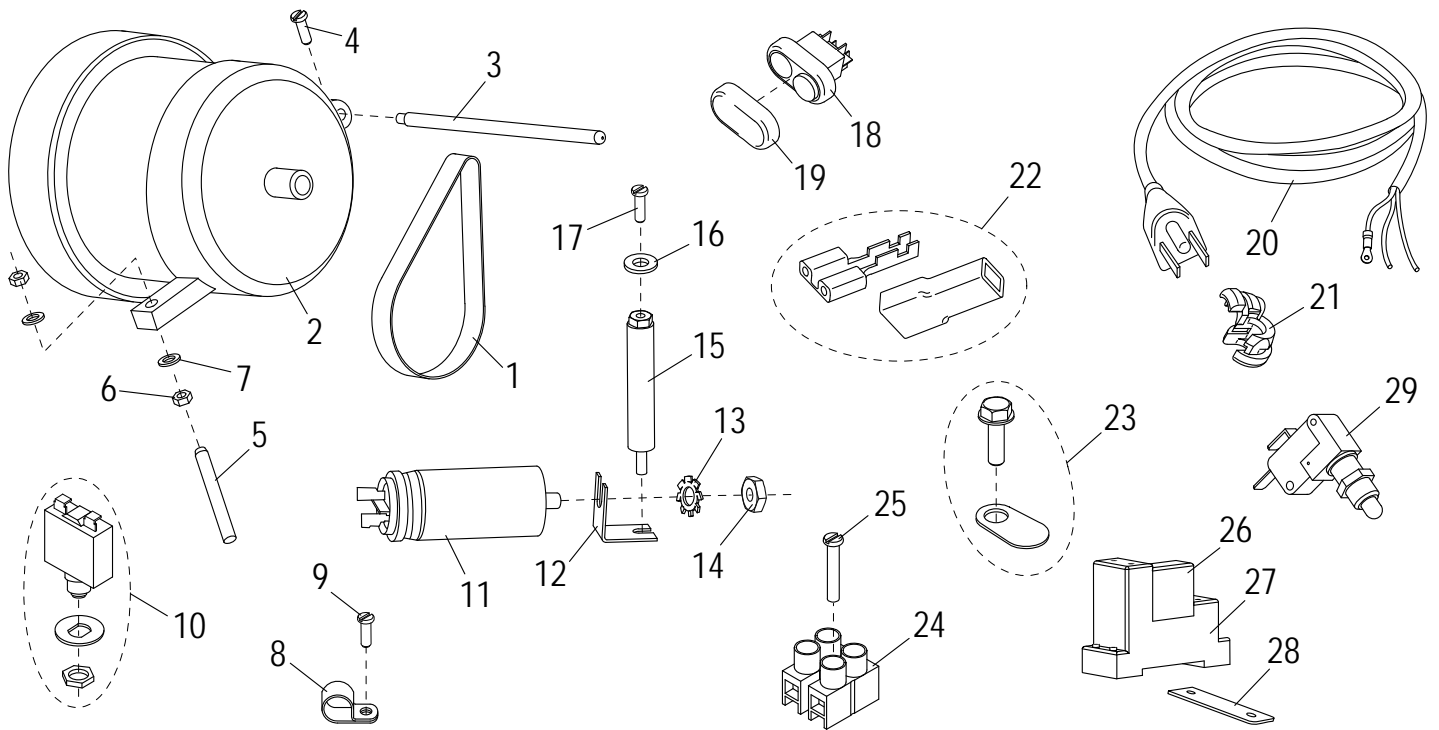



## SCR12 Electrical Components

Item	Part Number	Description	Qty	Serial Number
1	M024	Drive Belt	1	
2	M030	Knife Motor	1	
3	M031	Post, Motor Pivot	1	
4	H00189	Cheese Hd Screw M4-0.7x10 Slotted - Zn	1	
5	H00347	Set Screw M6x50 Flat Pt.	1	
6	H00020	Hex Nut, M6	2	
7	H00014	Flat M6 Washer - Zn	2	
8	M037	Cable Clamp	1	
9	H00061	Hex Head Screw M5x10, Zinc	1	
10	M038	Motor Reset Switch	1	
11	M039	Capacitor, 16 µf	1	
12		Bracket, Capacitor Mounting	1	
13	H00335	Lock M8 Washer	1	
14	H00192	Hex Nut M8-1.25,13mm Width,4 mm Height-Zn	1	
15	M00358	Standoff, Cover Spacer	1	
16	H00014	Flat M6 Washer - Zn	1	
17	H00061	Hex Head Screw M5x10, Zinc	1	
18	MCR69	Power Switch	1	
19	MCR59	Power Switch Cover	1	
20	M110	Power Cord & Plug	1	
21	M111	Strain Relief	1	
22	M00233	Female Terminal/Insulator Set	15	
23	M00334	Ground Screw/Marking Tab Set	1	
24	MB80/2	Terminal Block	1	
25	H00203	Terminal Block Mounting Screw	1	
26	MCR75	Relay	1	
27	MCR76	Relay Socket	1	
28	M00360	Relay Mounting Plate	1	
29	M026	Hub Assembly Microswitch	1	

