

Parts Catalog



SP20E-220-240501

Mixer

Model: SP20E-220-240501

05/22/19 Rev. -

IMPORTANT!

TO EXPEDITE SHIPMENT OF PARTS, ALWAYS SPECIFY MODEL, REV,
PART NUMBER, AND SERIAL NUMBER OF UNIT.

GLOBE FOOD EQUIPMENT COMPANY

2215 East River Road

Dayton, Ohio 45439

Parts Department

Toll Free 1-800-745-6238 · Fax (937) 290-0585

E-Mail: info@globefoodequip.com

Website: www.globefoodequip.com

Not for resale

Table of Contents

Description	Page
SP20E Base Components	4
SP20E Head Components	8
SP20E Hub Assembly Components	12
SP20E Planetary Components	14
SP20E Gearbox Components	16
SP20E Motor Components	20
SP20E Motor Brake & Digital Timer Components	22
SP20E Wiring Diagram - 220V Single Phase	24



SP20E Base Components

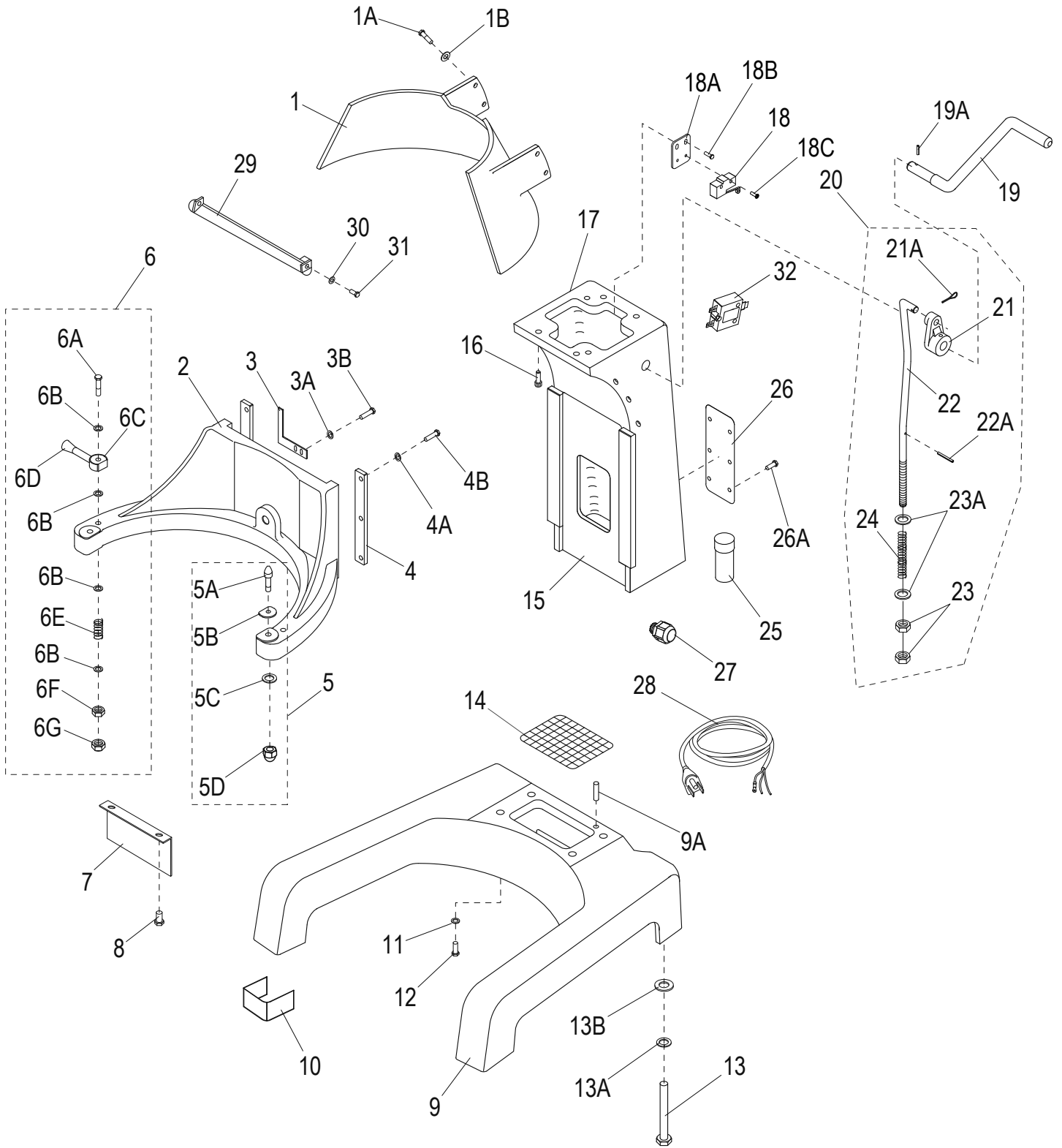



SP20E Base Components

Item	Part Number	Description	Qty	Serial Number
1	X20023	Rear Guard	1	
1A		Screw M6x14mm Hex Hd	4	
1B		Washer M6 Flat	4	
2	X20021-DG	Bowl Cradle	1	
3	X10190	Touch Mass	1	
3A		Washer M4 Split Lock	2	
3B		Screw M4x14mm Hex Hd	2	
4	X20022	Bowl Slide	2	
4A		Washer M6 Split Lock	6	
4B		Screw M6x14mm Hex Hd	6	
5	X20087	Dowel Screw Assembly (Incl. items 5A-5D)	2	
5A		Dowel Screw	2	
5B	X01759	Flat Washer M8, ID-8.4, OD-24, TH-2mm	2	
5C	H00335	Lock Washer M8, ID-8.4, OD-15, TH-0.8mm Zn	2	
5D	X10088	Cap Nut M8-1.25, OD-13, TH-15mm Zinc	2	
6	X10020	Bowl Clamp Assembly (Set/2) (Incl. items 6A-6G)	1	
6A	X20086	Ext. Hex Hd Screw M8-1.25x80mm, Zn	2	
6B	X10189	Washer M8 Flat	8	
6C	X10020-1	Bowl Clamp (Set/2)	1	
6D		Bowl Clamp Handle	2	
6E		Spring	2	
6F		Nut M8 Hex	2	
6G		Nut M8 Acorn	2	
7		Cover, Cradle	1	
8	X40056	Truss Hd Screw PHH M6-1.0x10mm, SS-18	2	
9	X20024-DG	Mixer Base	1	
9A		Dowel Pin Ø8x16mm	2	
10	X10136	Front/Rear Rubber Feet (Set/4)	4	
11	X10034	Washer M10 Flat	4	
12		Screw M10x40mm Hex Hd	4	
13	X10025	Ext. Hex Hd Screw M10-1.5x60mm, Zinc	4	
13A		Washer M10 Split Lock	4	
13B	X10034	Washer M10 Flat	4	
14	X20031	Screen	1	
15	X20035-1-DG	Mixer Column	1	
16	X08077	Ext. Hex Hd Screw M8-1.25x20mm, Zinc	4	
17	X02586	Arabic, Hazardous Voltage LBL (Not Shown)	1	
17	X02587	Thai, Hazardous Voltage LBL (Not Shown)	1	
17	X02588	Portuguese/Brazil, Hazardous Voltage LBL (Not Shown)	1	
17	X02589	Spanish, Hazardous Voltage LBL (Not Shown)	1	
17	X02590	United Kingdom, Hazardous Voltage LBL (Not Shown)	1	
18	X10057	Microswitch, Interlock	1	
18A	X30216	Bracket, Microswitch Mounting	1	
18B	X30217	Truss Hd Screw-PHH, M6-1.0x10mm, SS-18	2	
18C	X30218	Screw M4x24mm Pan Hd & Flatwasher	2	
19	X20040	Bowl Lift Arm	1	
19A	X10039	Dowel Pin Ø5x30mm	1	
20	X20037A	Bowl Lift Arm Assembly (Incls. items 21-24)	1	
21		Bowl Lift Cam	1	
21A		Cotter Pin	1	
22		Bowl Lift Rod	1	
22A		Roll Ø3x28mm Pin	1	
23	H01029	Hex Nut M10-1.5, OD-17, HT-8mm, Class 8, Zn	2	



SP20E Base Components

Item	Part Number	Description	Qty	Serial Number
23A		Washer M10 Flat	2	
24		Spring	1	
25	X20026	Capacitor, Start - 300Mf	1	
26	X10191	Cover Plate	1	
26A	X25051	Rd Hd Screw-PHH #10-24x1/4, SS-18	4	
27		Strain Relief	1	
28		Power Cord And Plug	1	
29	X20184	Front Guard, Mixer Column	1	
30		Washer M6 Flat	2	
31	X40056	Truss Hd Screw PHH M6-1.0x10mm, SS-18	2	
32	X20027-1	Circuit Breaker (8A)	1	



INTENTIONALLY LEFT BLANK PAGE



SP20E Head Components

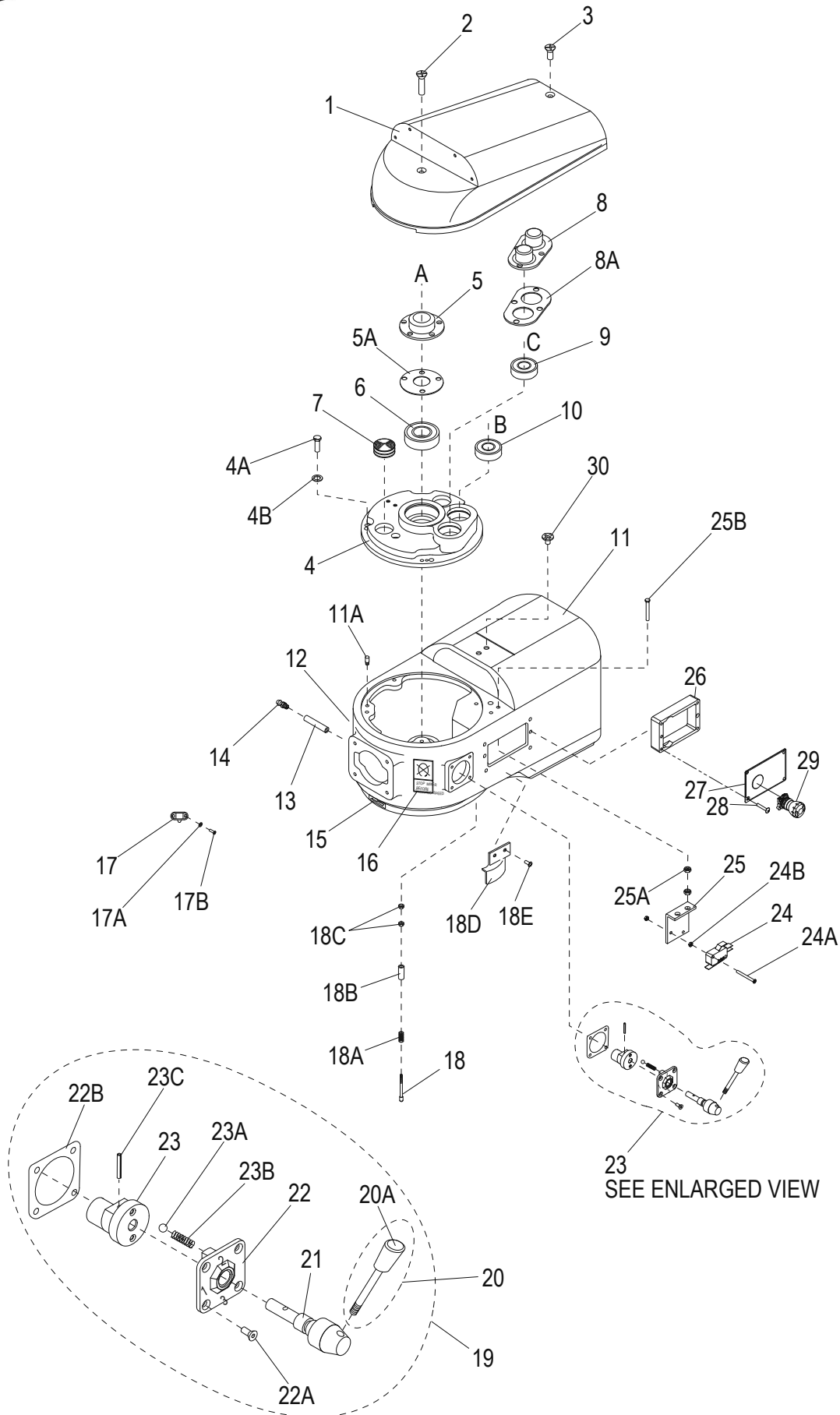



SP20E Head Components

Item	Part Number	Description	Qty	Serial Number
1	X10001-2-DG	Transmission Cover-Front Controls	1	
2	X10180	Flat Hd Screw-PHH 1/4"-20x1.25", Zinc	1	
3	X10181	Flat Hd Screw-PHH 1/4"-20x0.75", Zinc	1	
4	X10074	Transmission Case Lid	1	
4A		Screw M6x16mm Hex Hd	4	
4B		Washer M6 Split Lock	4	
5	X10072	Bearing Retainer Cap	1	
5A	X10187	Gasket, Bearing Retainer	1	
6	X10010	Ball Bearing	1	
7	X10073	Oil Plug	1	
8	X10071	Twin Bearing Retainer	1	
8A	X10188	Gasket, Twin Bearing Retainer	1	
9	X10068	Ball #35 Bearing	1	
10	X10068	Ball #35 Bearing	1	
11	X10059-1	Case, Transmission - Removable Bowl Guard	1	
11A		Locating Pin Ø8xM6x10mm	2	
12	X02580	United Kingdom, Maint. of Intern. Gear LBL	1	
12	X02579	Spanish, Maint. of Intern. Gear LBL	1	
12	X02578	Portuguese/Brazil, Maint. of Intern. Gear LBL	1	
12	X02577	Thai, Maint. of Intern. Gear LBL	1	
12	X02576	Arabic, Maint. of Intern. Gear LBL	1	
13	X10217	Grease Tube	1	
14	X10900	Grease Fitting	1	
15	X91012	Label, Arrow	1	
16	X02585	United Kingdom, Avoid Gear Damage LBL	1	
16	X02584	Spanish, Avoid Gear Damage LBL	1	
16	X02583	Portuguese/Brazil, Avoid Gear Damage LBL	1	
16	X02582	Thai, Avoid Gear Damage LBL	1	
16	X02581	Arabic, Avoid Gear Damage LBL	1	
17	X10134	Safety Guard Spring Lock	1	
17A		Washer M3 Split Lock	2	
17B	X10134B	Round Hd Screw-PHH M3-0.5x8mm, SS-18	2	
18	X10043N	Touch Shaft, Nylon	1	
18A	X30095	Spring	1	
18B		Tube	1	
18C	X30186	Hex Nut M5-0.8 OD-8, TH-4mm, Zinc	2	
18D	X20516	Cover, Touch Shaft (Removable Bowl Guard)	1	
18E		Screw M5x8mm Truss Hd	2	
19	X10045-48	Gear Shift Lever Assembly (Incls. items 20-23C)	1	
20	X10045	Gear Shift Lever Assy With Knob (Incls. item 20A)	1	
20A	X10045-1	Knob, Gear Shift	1	
21		Shaft	1	
22		Cover	1	
22A	X25166	Flat Hd Screw-PHH M5-0.8x16mm, Zinc	4	
22B	X10199	Gasket	1	
23		Shaft Bias	1	
23A		Roller	2	
23B		Spring	2	
23C		Roll Ø3x28mm Pin	1	
24	X10057	Microswitch, Interlock	1	
24A		Screw M3x12mm Switch Mounting	2	
24B		Nut M3 Hex	4	
25	X10058	Bracket, Microswitch	1	



SP20E Head Components

Item	Part Number	Description	Qty	Serial Number
25A		Nut M6 Hex	4	
25B		Screw M6x40mm Hex Hd - Bracket Mounting	2	
26	X10056	Block, Side Panel	1	
27	X02600	United Kingdom, Emergency Stop Panel LBL	1	
27	X02599	Spanish, Emergency Stop Panel LBL	1	
27	X02598	Portuguese/Brazil, Emergency Stop Panel LBL	1	
27	X02597	Thai, Emergency Stop Panel LBL	1	
27	X02596	Arabic, Emergency Stop Panel LBL	1	
28	H02513	Truss Hd-Combo Screw #10-24x1.25"	4	
29	X02515	Button, Emergency Stop	1	
30	X10131	Rd Hd Screw-PHH #10-24x3/8", Zinc	1	



INTENTIONALLY LEFT BLANK PAGE



SP20E Hub Assembly Components

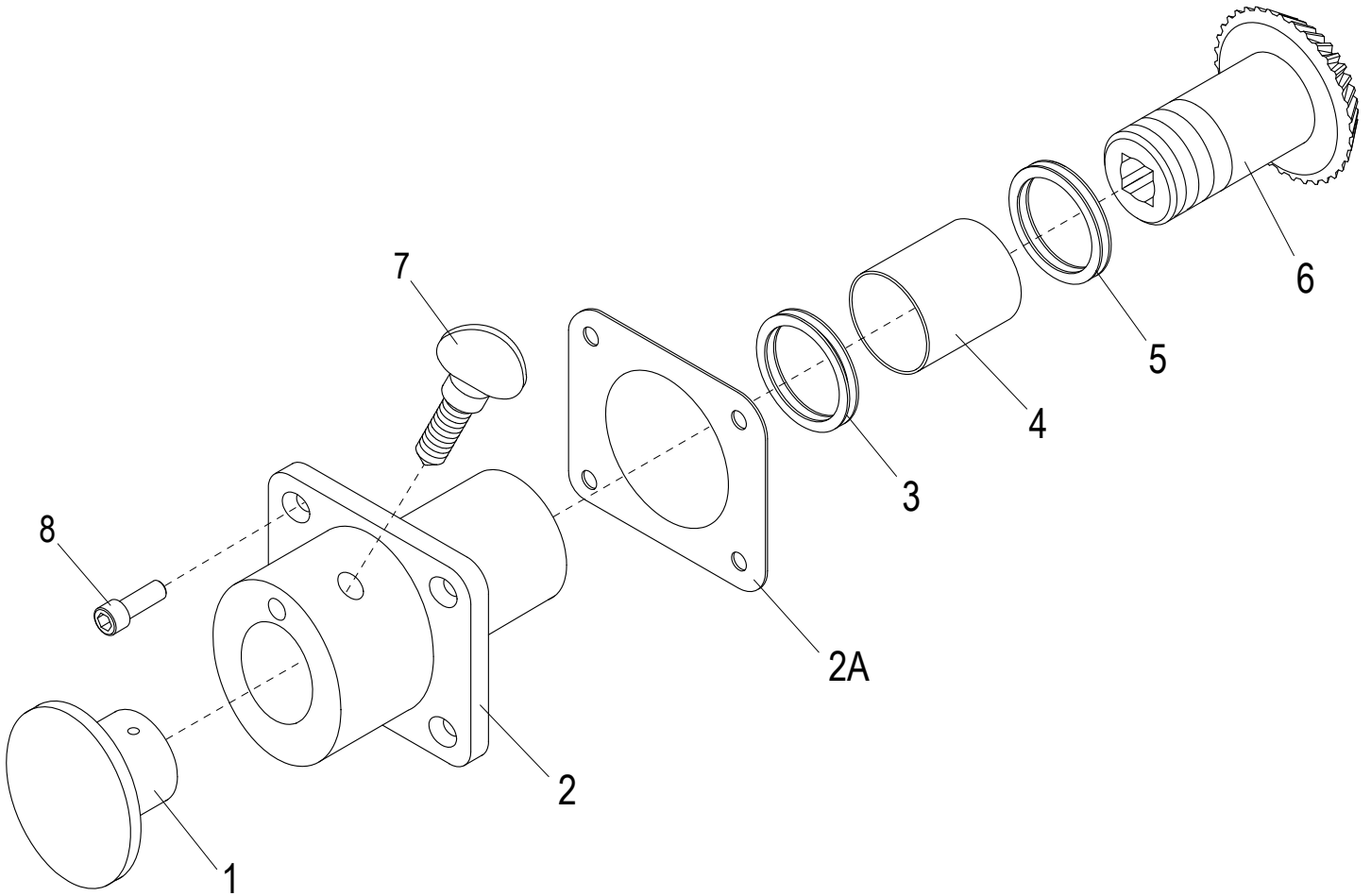



SP20E Hub Assembly Components

Item	Part Number	Description	Qty	Serial Number
1	X10007	Attachment Hole Plug	1	
2	X10006-DG	Attachment Hub	1	
2A		Gasket	1	
3	X10089	Oil 45x35x8mm Seal	1	
4	X10075	Bearing	1	
5	X30018-1	Thrust Washer ID-35mm, OD-55mm, TH-1mm	2	
6	X10003	Level Drive Gear (35T)	1	
7	X10005	Thumb Screw 1/2-13x3/4"	1	
8	X80B52	Socket Hd Cap Screw M6-1.0x20mm, B.O.	4	



SP20E Planetary Components

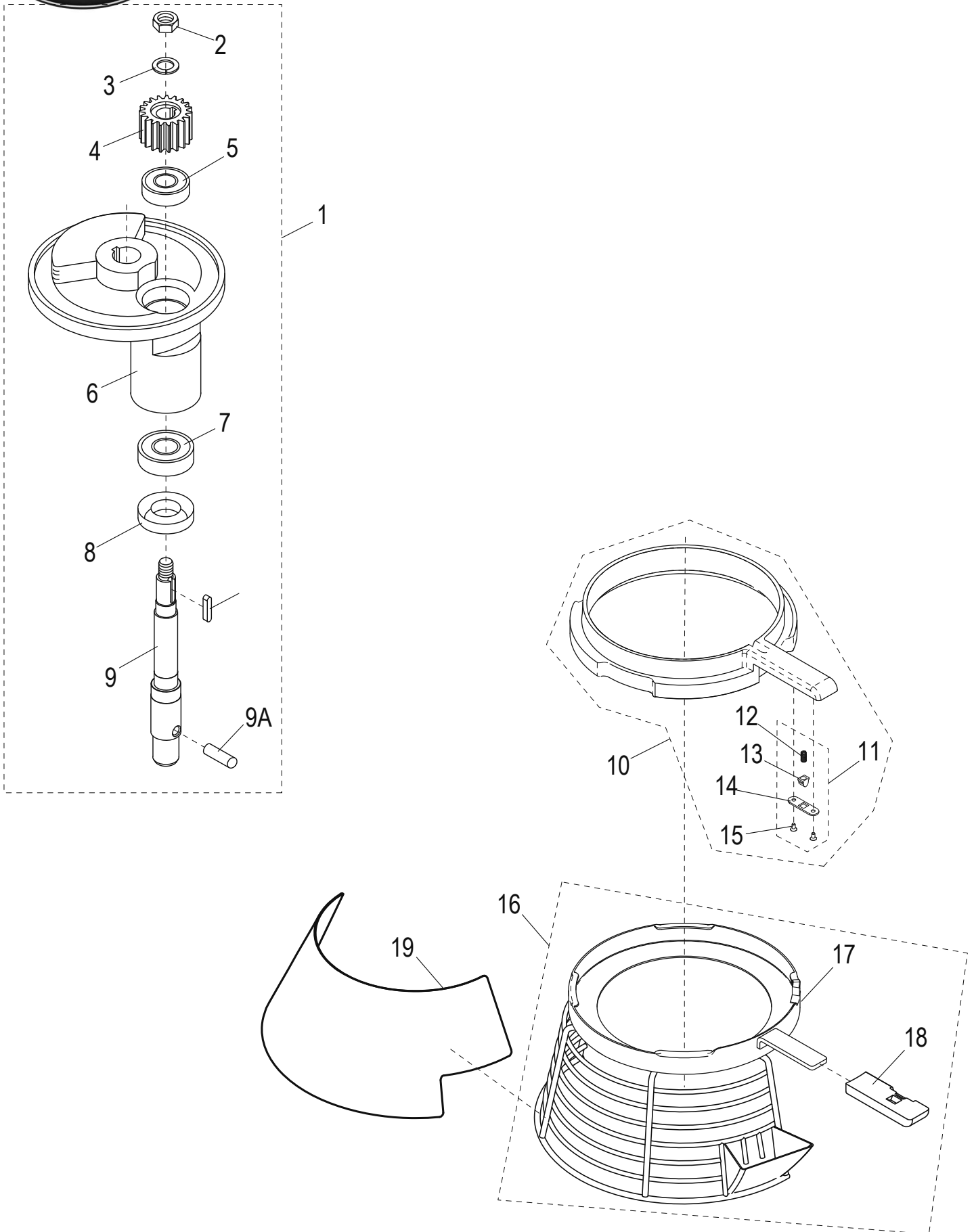



SP20E Planetary Components

Item	Part Number	Description	Qty	Serial Number
1	X10008-82	Complete Planetary Assembly (Incls. items 2-9B)	1	
2	X10008	Hex Nut M12-1.25, OD-19, HT-10mm, Zinc	1	
3	X80B05	Lock Washer M12, ID-12.7, OD-21.1, TH-2.5mm, SS	1	
4	X10009	Pinion, Beater (19T)	1	
5	X10010	Ball Bearing	1	
6	X10011-DG	Planetary Holder	1	
7	X10012	Ball Bearing	1	
8	X10013	Oil Seal	1	
9	X10015	Planetary Shaft	1	
9A	X10080	Dowel Pin	1	
9B	X10014	Key H-5xW-5xL-17mm, Round Ends	1	
10	X200S2	Plastic Slide Sheath, Removable Safety Guard (Incls. items 11-15)	1	
11	X200S3	Spring Plunger Hardware Kit	1	
12		Spring	1	
13		Plunger	1	
14		Plate, Plunger Retention	1	
15		Screw M3x8mm Flat Hd	2	
16	X200S1	Bowl Guard Assembly, Stainless Steel (Incls. items 17-18)	1	
17		Removable Bowl Guard	1	
18	X20504	Handle, Plastic - Removable Safety Guard	1	
19	X02620	Cover, Plastic	1	



SP20E Gearbox Components

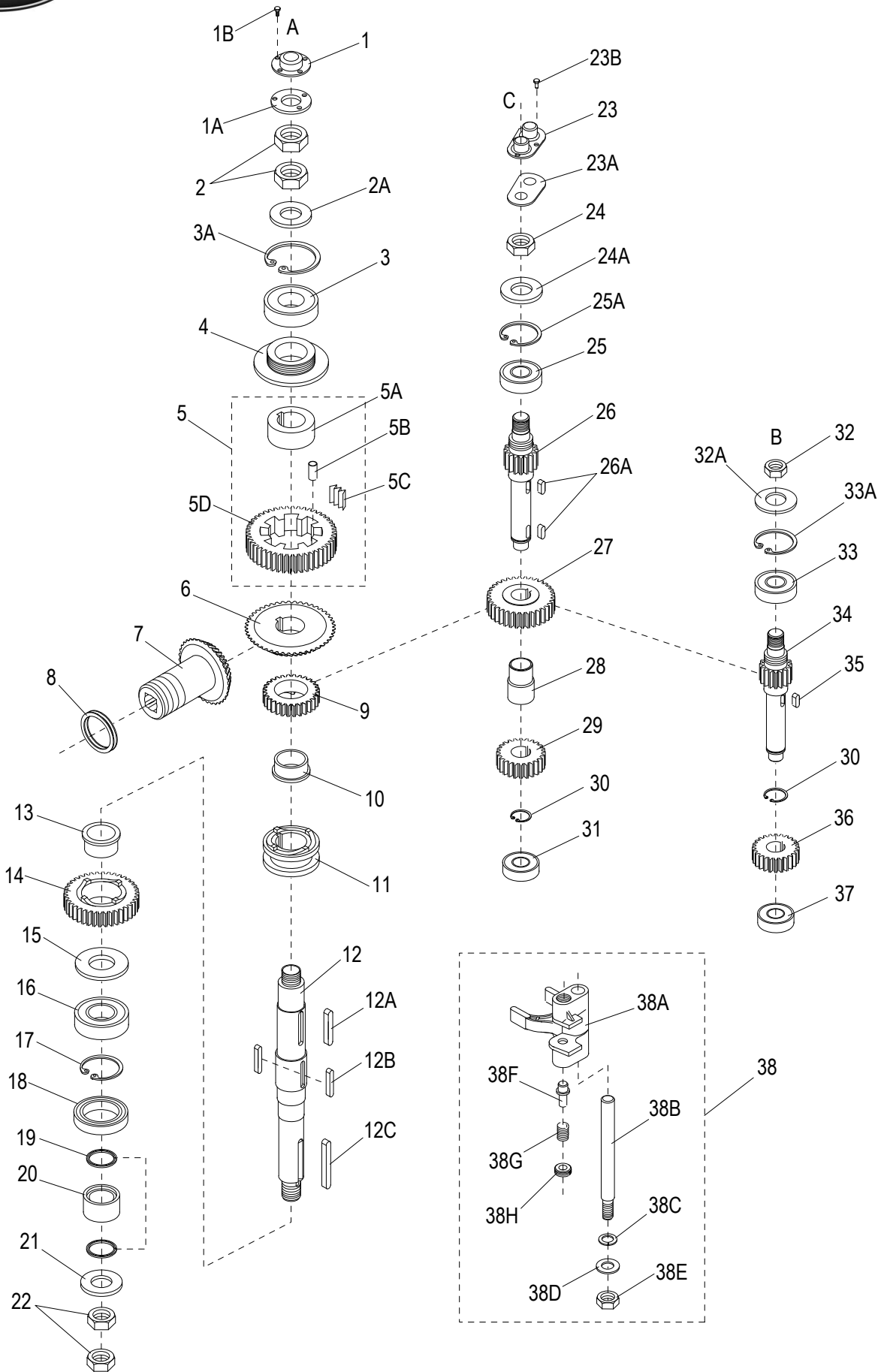



SP20E Gearbox Components

Item	Part Number	Description	Qty	Serial Number
1	X10072	Bearing Retainer Cap	1	
1A	X10187	Gasket, Bearing Retainer	1	
1B	X10133	Pan Hd Screw-PHH M6-1.0x10mm, SS	4	
2	X10132	Thin Hex Nut 1/2-20, OD-1/2", TH-11/64" Zn	2	
2A		Washer 1/2" Flat	1	
3	X10010	Ball Bearing	1	
3A		Retaining Ring	1	
4	X10090	Lead-In Oil Pad	1	
5	X10091-94	Slow Speed Gear Assembly (Incl. items 5A-5D)	1	
5A	X10091	Bushing	1	
5B		Dowel Ø8x16mm Pin	1	
5C	X10093	Slice Spring	1	
5D		Gear, Slow Speed (46T)	1	
6	X10095	Gear, Bevel (46T)	1	
7	X10003	Level Drive Gear (35T)	1	
8	X30018-1	Thrust Washer ID-35mm, OD-55mm, TH-1mm	1	
9	X10096	Gear, Clutch (29T)	1	
10	X10097	Bushing, Clutch	1	
11	X10110	Sleeve, Clutch	1	
12	X10107	Drive Shaft	1	
12A	X10098	Key H-6xW-6xL-28mm, Round Ends	1	
12B	X10109	Shaft Key 5x5x27mm	1	
12C	X10108	Shaft Key 6x6x45mm	1	
13	X10097	Bushing, Clutch	1	
14	X10100	Gear, Clutch (38T)	1	
15	X10101	Washer, Stepped	1	
16	X10102	Ball Bearing	1	
17	X20214	Int. Retaining Ring ID-2", OD-2.210", TH-0.062", B.O.	1	
18	X10105	Oil Seal	1	
19	X10103	O-Ring 28x22x3mm	2	
20	X10104	Guard, Oil Bushing	1	
21		Washer M20 Flat	1	
22	X10106	Thin Hex Nut 3/4"-16, OD-1-1/8", HT-27/64", Zn	2	
23	X10071	Twin Bearing Retainer	1	
23A	X10188	Gasket, Twin Bearing Retainer	1	
23B	X10131	Rd Hd Screw-PHH #10-24x3/8", Zinc	4	
24	X10130	Thin Hex Nut 3/4"-16, OD-1-18", HT-27/64", Zn	1	
24A		Washer 3/8" Flat	1	
25	X10068	Ball #35 Bearing	1	
25A		Retaining Ring	1	
26	X10129	Transmission Shaft (15T)	1	
26A	X10128	Key H-5xW-5xL-14mm, Round Ends	2	
27	X10126	Gear (32T)	1	
28	X10122	Bushing, Spacer	1	
29	X10121	Gear (24T)	1	
30	X10120	Retaining Ring STW-19	2	
31	X10117	Drive Shaft Upper Ball Bearing	1	
32	X10125	Thin Hex Nut 3/8-24, OD-9/16", TH-7/32", Zn	1	
32A		Washer M10 Flat	1	
33	X10068	Ball #35 Bearing	1	
33A		Retaining Ring #35	1	
34	X10124	Shaft, Master (15T)	1	
35	X10123	Key H-5xW-5xL-18mm, Round Ends	1	



SP20E Gearbox Components

Item	Part Number	Description	Qty	Serial Number
36	X10118-24T	Worm Wheel (24T)	1	
37	X10117	Drive Shaft Upper Ball Bearing	1	
38	X10111-116	Yoke Shifter Assembly (Incls. items 38A-38H)	1	
38A		Yoke Shifter	1	
38B		Guide, Rod Shifter	1	
38C		Washer 3/8" Split Lock	1	
38D		Washer 3/8" Flat	1	
38E		Nut 3/8-16 Stop	1	
38F		Plunger, Yoke Shifter	1	
38G		Spring, Retainer	1	
38H		Spring, Yoke Shifter	1	



INTENTIONALLY LEFT BLANK PAGE



SP20E Motor Components

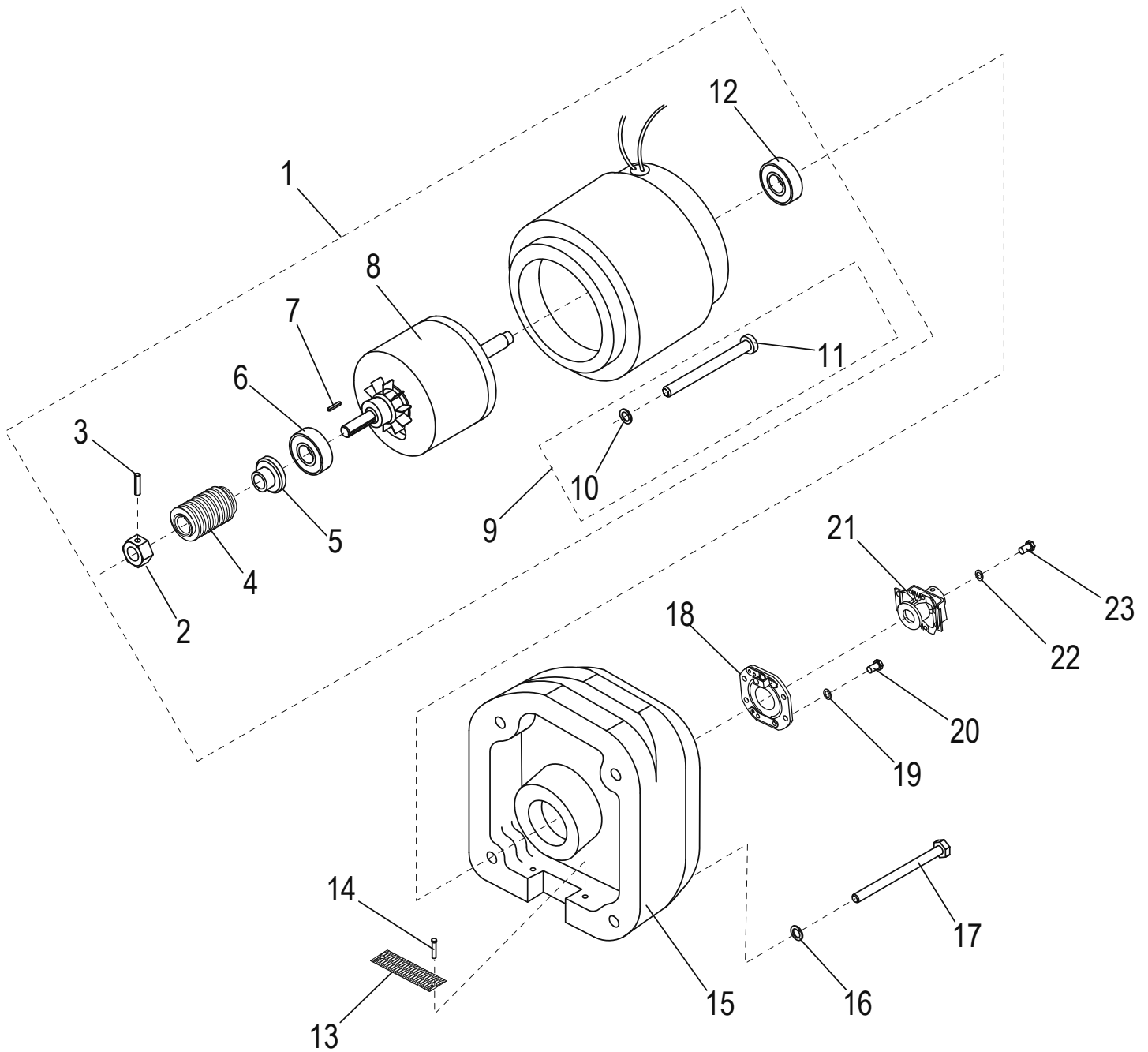



SP20E Motor Components

Item	Part Number	Description	Qty	Serial Number
1	X02508	Motor Assembly with Brake, 1/2 HP (Incls. items 2-12)	1	
2	X20066	Hex Nut 7/16, OD-11/16", TH-3/8", Zn	1	
3	X20067	Roll Pin M3x16mm	1	
4	X02516	Worm (5T), 50Hz	1	
5	X20060	Spring Shock Absorber	1	
6	X08114	Ball Bearing	1	
7	X20202	Key H-3xW-3xL-18mm, Round Ends	1	
8		Motor Shaft	1	
8		Motor Coil	1	
9	X20206-207	Screw And Lock Washer Set (Incls. items 10-11)	1	
10		Washer M5 Split Lock	4	
11		Screw M5x55mm Hex Hd	4	
12	X10010	Ball Bearing	1	
13	X20031	Screen	1	
14		Rivet	2	
15	X10054	Transmission Cover, Rear	1	
16	1226	Washer M6 Split Lock	4	
17	X20161	Ext. Hex Hd Screw #1/4-20x2.25", Zn	4	
18	X10051	Switch, Platinum	1	
19	X20207	Lock Washer M5, ID-5.4, OD-8.8, TH-2mm, SS-18	2	
20		Screw M5x10mm Hex Hd	2	
21	X02517	Clutch, 50Hz	1	
22	X20207	Lock Washer M5, ID-5.4, OD-8.8, TH-2mm, SS-18	1	
23		Screw M5x10mm Hex Hd	1	
24	X20063	Fan (Not Shown)	1	



SP20E Motor Brake & Digital Timer Components

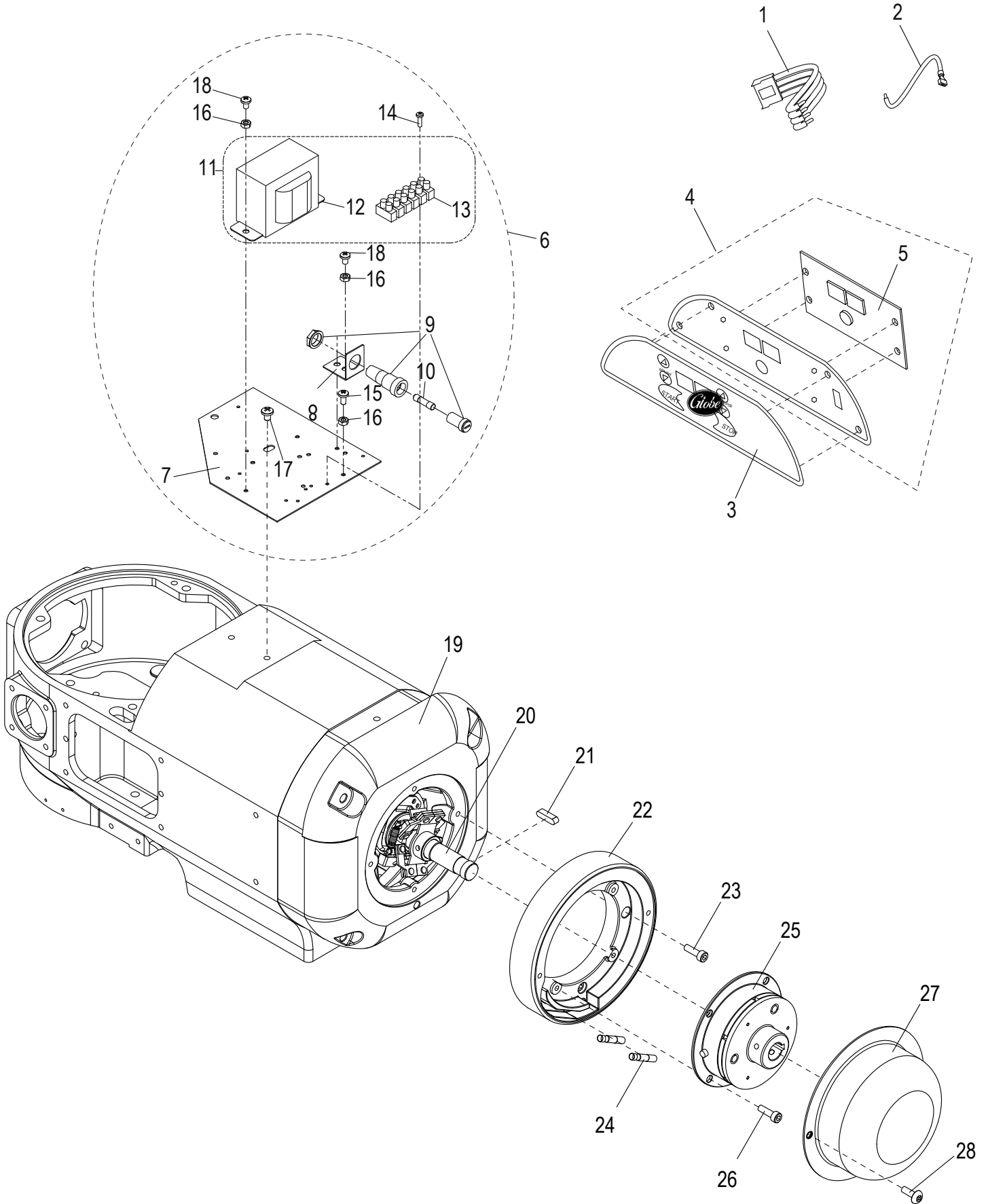



SP20E Motor Brake & Digital Timer Components

Item	Part Number	Description	Qty	Serial Number
1	X00675	4 Wire Harness With Connector	1	
2	X00676	Single Wire With Quick Connect	2	
3	X00565	Switch, Membrane	1	
4	X01336	Aluminum Panel (Incls. item 5)	1	
5	X00568	Control Board	1	
6	X02492	Transformer Assembly (Incls. items 7-18)	1	
7	X02493	Plate, Mounting	1	
8		Bracket, Mounting	1	
9	X02072	Fixture, Fuse	1	
10	X00570	Control Transformer Fuse	1	
11	X02499	24V-15V Transformer, Control (Incls. items 12-13)	1	
12		Control Transformer	1	
13		Connecting Block	1	
14	H02502	Cheese Hd Screw-Slotted M3x10mm, Zn	2	
15	H02503	Cheese Hd Screw-PHH M4x6mm, Zn	1	
16	H02504	Hex Nut M4, OD-8mm, TH-3.5mm, Zn	5	
17	H02505	Truss Hd-Combo Screw #10-24x1/4", Zn	2	
18	H02506	Round Hd-Combo Screw M4x6mm, Zn	4	
19	X20054-1	Motor Cover, Rear - Mtr Brake	1	
20		Motor Shaft	1	
21	X10014	Key H-5xW-5xL-17mm, Round Ends	1	
22	X20509	Housing, Brake	1	
23		Screw 3/16" Socket Hd	4	
24		Connector	2	
25	X20511	Magnetic Brake	1	
26		Screw M5x12mm Socket Hd	4	
27	X20510	Cover, Magnetic Brake	1	
28		Screw M5x10mm Button Hd	2	



SP20E Wiring Diagram - 220V Single Phase

