

Parts Catalog



SP30E-220-240501

Mixer

Model: SP30E-220-240501

5/22/2019 Rev. -
IMPORTANT!

TO EXPEDITE SHIPMENT OF PARTS, ALWAYS SPECIFY MODEL, REV,
PART NUMBER, AND SERIAL NUMBER OF UNIT.

GLOBE FOOD EQUIPMENT COMPANY

2215 East River Road
Dayton, Ohio 45439

Parts Department

Toll Free 1-800-745-6238 · Fax (937) 290-0585

E-Mail: info@globefoodequip.com

Website: www.globefoodequip.com

Not for resale

Table of Contents

Description	Page
SP30E Base Components	4
SP30E Head Components	8
SP30E Hub Assembly Components	12
SP30E Planetary Components	14
SP30E Gearbox Components	16
SP30E Motor Components	20
SP30E Motor Brake Components	22
SP30E Digital Components	24
SP30E Wiring Diagram, Single Phase	26



SP30E Base Components

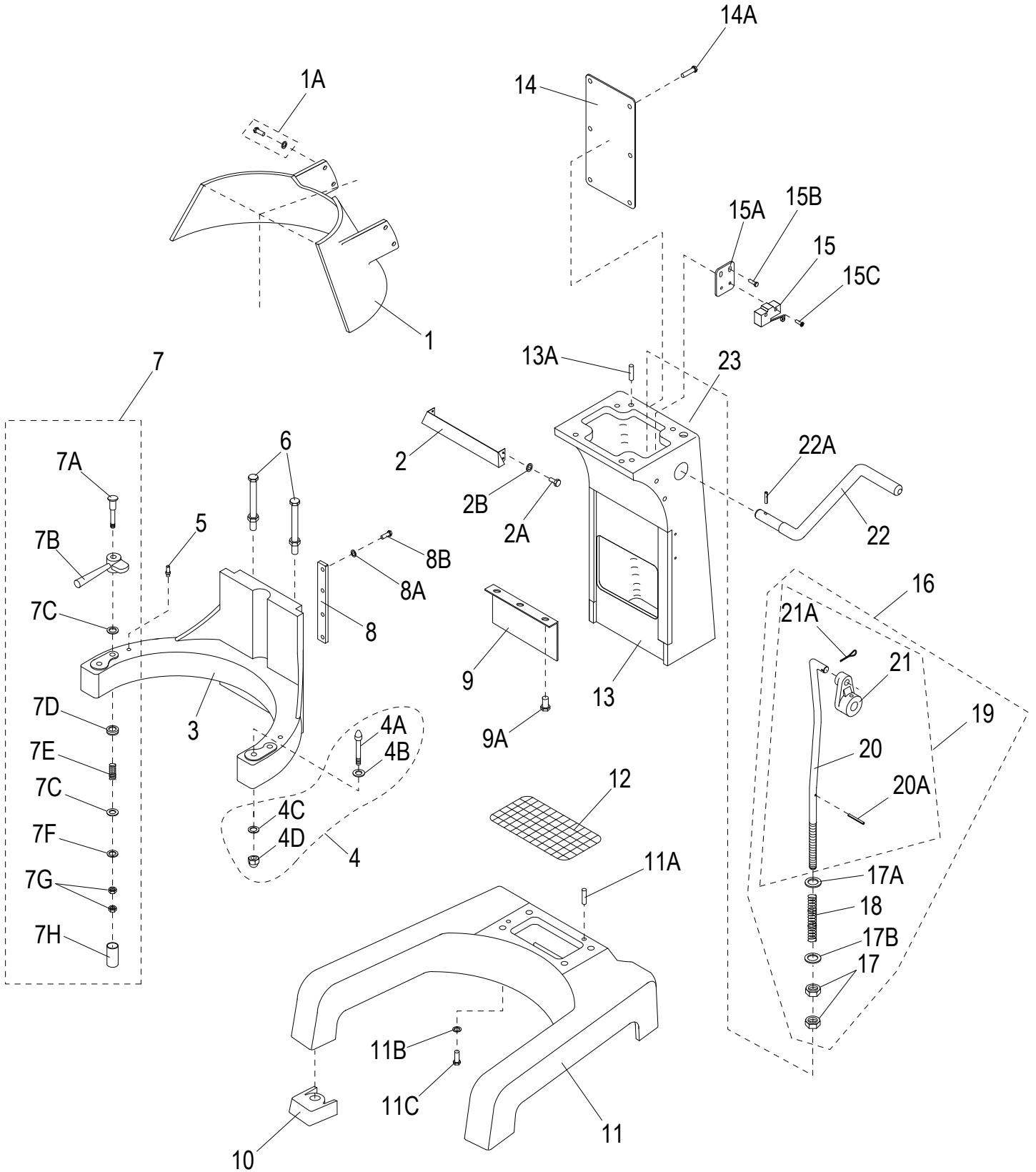



SP30E Base Components

Item	Part Number	Description	Qty	Serial Number
1	X30036	Guard, Rear	1	
1A	X30101	Hex Screw M8x20mm & Flat Washer	4	
2	X30102	Mixer Column Cover	1	
2A		Screw M6x10mm Hex Hd	3	
2B	X25069	Flat Washer, M6 ID-6mm, OD-24mm, TH-3mm, Thick	3	
3	X30034-DG	Bowl Cradle	1	
4	X30109	Dowel Screw Assembly (Incl. items 4A-4D)	2	
4A		Dowel Screw	2	
4B		Washer M12 Lock	2	
4C		Washer M12xOD30x1.0mm	2	
4D	X40110	Cap Nut, M12-1.75, OD-19mm, HT-22mm, Class 10, Zn	2	
5	X30167	Bowl Clamp Stop Pin	2	
6	X40106	Screw M10x54mm Hex Hd/Nut (Touch Shaft)	1	
7	X30033	Bowl Clamp Assembly (Set/2) (Incl. items 7A-7H)	1	
7A	X30108	Bowl Clamp Hardware Kit	2	
7B	X30033-2	Bowl Clamp (Set/2, New Style)	1	
7C		Washer M12 Flat	4	
7D		Hardware Cap Retainer	2	
7E		Spring	2	
7F		Washer M12 Split Lock	2	
7G		Nut M12 Jam	4	
7H		Hardware Cap	2	
8	X30035	Cradle Slide Guides	2	
8A	X08076	Flat Washer, M8 ID-8.4mm, OD-16mm, TH-1.6mm, Zn	8	
8B	X30069	Screw M8x30mm Hex Hd	8	
9	X30164	Cover, Cradle, S/S	1	
9A		Screw M6x14mm Hex Hd	3	
10	X30162-163	Front/Rear Rubber Feet (Set)	1	
11	X30038-DG	Mixer Base	1	
11A		Dowel Pin Ø8x16mm Column Locator	2	
11B	X80B05	Lock Washer M12, ID-12.7, OD-21.1, TH-2.5mm, SS	4	
11C	X80B04	Ext. Hex Hd Screw M12-1.75x40mm, B.O.	4	
12	X30037	Base Screen	1	
13	X000647		1	
13A	X30178	Dowel Pin Ø8x16mm Head Locator	2	
14	X30055	Plate, Rear Cover	1	
14A	X30056	Truss Hd Screw M5-0.8x12mm, SS	6	
15	X30219	Microswitch, Bowl Lift	1	
15A	X30216	Bracket, Microswitch Mounting	1	
15B	X30217	Truss Hd Screw-PHH, M6-1.0x10mm, SS-18	2	
15C	X30218	Screw M4x24mm Pan Hd & Flatwasher	2	
16	X30211A	Bowl Lift Rod Assembly (Incl. items 17-21A)	1	
17	X30215	Hex Nut M12-1.75, OD-19mm, HT-10mm, Zn	2	
17A	X30213	Lg. Flat Washer M14, ID-15mm, OD-44mm, TH-3mm, SS	2	
17B	X01370	Washer M12 Flat	1	
18	X30214	Spring	1	
19	X01371	Bowl Lift Rod with Cam and Pin (Incl. items 20-21A)	1	
20		Bowl Lift Rod	1	
20A		Roll M4x30mm Pin	1	
21		Bowl Lift Cam	1	
21A		Cotter Pin	1	
22	X30208	Bowl Lift Arm	1	
22A	X30209	Roll M5x30mm Pin	1	



SP30E Base Components

Item	Part Number	Description	Qty	Serial Number
23	X02595	United Kingdom, Hazardous Voltage LBL	1	
23	X02594	Spanish, Hazardous Voltage LBL	1	
23	X02593	Portuguese/Brazil Hazardous Voltage LBL	1	
23	X02592	Thai, Hazardous Voltage LBL	1	
23	X02591	Arabic, Hazardous Voltage LBL	1	
24	952-12	Strain Relief, Liquid Tight	(Not Shown)	1
25	X30155	Power Cord, 110V Mixer	(Not Shown)	1



INTENTIONALLY LEFT BLANK PAGE



SP30E Head Components

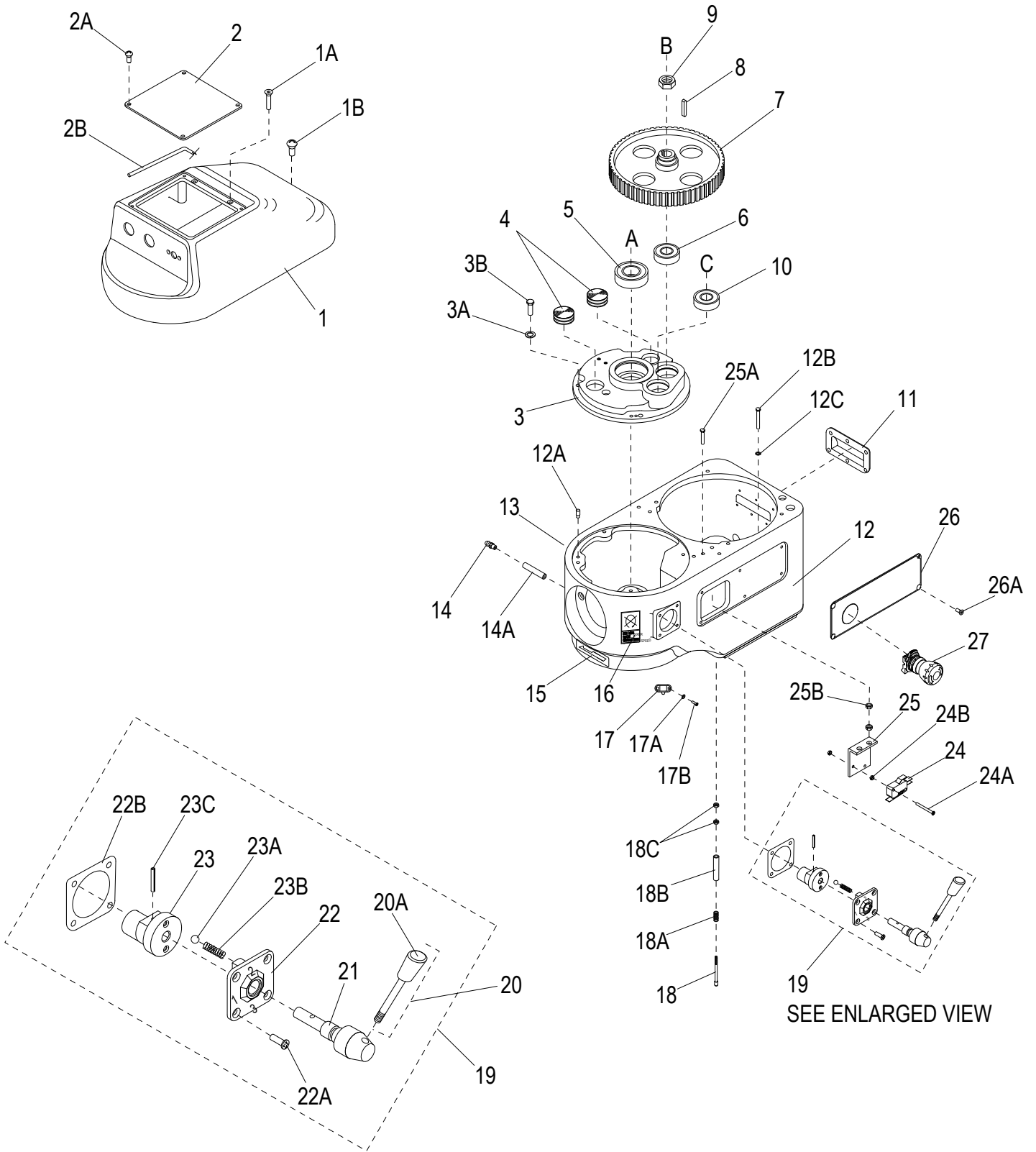



SP30E Head Components

Item	Part Number	Description	Qty	Serial Number
1	X30004-DG	Cover, Transmission	1	
1A	X30207	Flat Hd Screw-Socket M8-1.25x108mm, B.O.	2	
1B	X30220	Flat Hd Screw-Socket M6-1.0x90mm, B.O.	1	
2	X30002	Cover, Switch Box	1	
2A	X40056	Truss Hd Screw PHH M6-1.0x10mm, SS-18	4	
2B	X30003	Gasket	1	
3	X30077	Cover, Gear Housing	1	
3A	X30198	Lock Washer M8, ID-8.5mm, OD-12.7mm, TH-2mm	4	
3B	X30197	Ext. Hex Hd Screw M8-1.25x25mm, SS	4	
4	X10073	Oil Plug	2	
5	X30024	Ball Bearing	1	
6	X10012	Ball Bearing	1	
7	X30080	Wheel, Main Cog	1	
8	X30081	Shaft 5x5x30mm Key	1	
9	X30147	Thin Hex Nut M16-1.5, OD-24, HT-8, Zn	1	
10	X10012	Ball Bearing	1	
11	X30076	Plate, Ventilation	1	
12	X30087-1	Transmission Case, Removable Bowl Guard	1	
12A		Dowel Pin, Threaded	2	
12B	X30010	Socket Hd Cap Screw M8-1.25x90mm B.O.	2	
12C		Washer M8 Flat	2	
13	X02580	United Kingdom, Maint. of Intern. Gear LBL	1	
13	X02579	Spanish, Maint. of Intern. Gear LBL	1	
13	X02578	Portuguese/Brazil, Maint. of Intern. Gear LBL	1	
13	X02577	Thai, Maint. of Intern. Gear LBL	1	
13	X02576	Arabic, Maint. of Intern. Gear LBL	1	
14	X10900	Grease Fitting	1	
14A	X10217	Grease Tube	1	
15	X91012	Label, Arrow	1	
16	X02585	United Kingdom, Avoid Gear Damage LBL	1	
16	X02584	Spanish, Avoid Gear Damage LBL	1	
16	X02583	Portuguese/Brazil, Avoid Gear Damage LBL	1	
16	X02582	Thai, Avoid Gear Damage LBL	1	
16	X02581	Arabic, Avoid Gear Damage LBL	1	
17	X10134	Safety Guard Spring Lock	1	
17A		Washer M3 Flat	2	
17B	X10134B	Round Hd Screw-PHH M3-0.5x8mm, SS-18	2	
18	X30096N	Touch Shaft, Nylon	1	
18A	X30095	Spring	1	
18B		Tube	1	
18C	X30186	Hex Nut M5-0.8 OD-8, TH-4mm, Zinc	2	
19	X30057-60	Gear Shift Lever Assembly (Incl. items 20-23C)	1	
20	X30057	Gear Shift Lever With Knob	1	
20A	X30057-1	Knob, Gear Shift	1	
21		Shaft	1	
22		Cover	1	
22A	X30179	Flat Hd Screw-Socket M8-1.0x16mmHd, Zn	4	
22B	X30059-1	Gasket	1	
23		Shaft Bias	1	
23A		Roller	2	
23B		Spring	2	
23C		Roll Ø3x28mm Pin	1	
24	X10057	Microswitch, Interlock	1	



SP30E Head Components

Item	Part Number	Description	Qty	Serial Number
24A	854-2	Screw, Magnet Mounting	2	
24B	854-3	Nut, Magnet Mounting	4	
25	X30062	Bracket, Microswitch	1	
25A		Screw M6x20mm Hex Hd	2	
25B		Nut M6	4	
26	X02605	United Kingdom, Emergency Stop Panel LBL	1	
26	X02604	Spanish, Emergency Stop Panel LBL	1	
26	X02603	Portuguese/Brazil, Emergency Stop Panel LBL	1	
26	X02602	Thai, Emergency Stop Panel LBL	1	
26	X02601	Arabic, Emergency Stop Panel LBL	1	
26A	X30065	Truss Hd Screw-Phillips M5-0.8x10mm, SS	4	
27	X02515	Button, Emergency Stop	1	



INTENTIONALLY LEFT BLANK PAGE



SP30E Hub Assembly Components

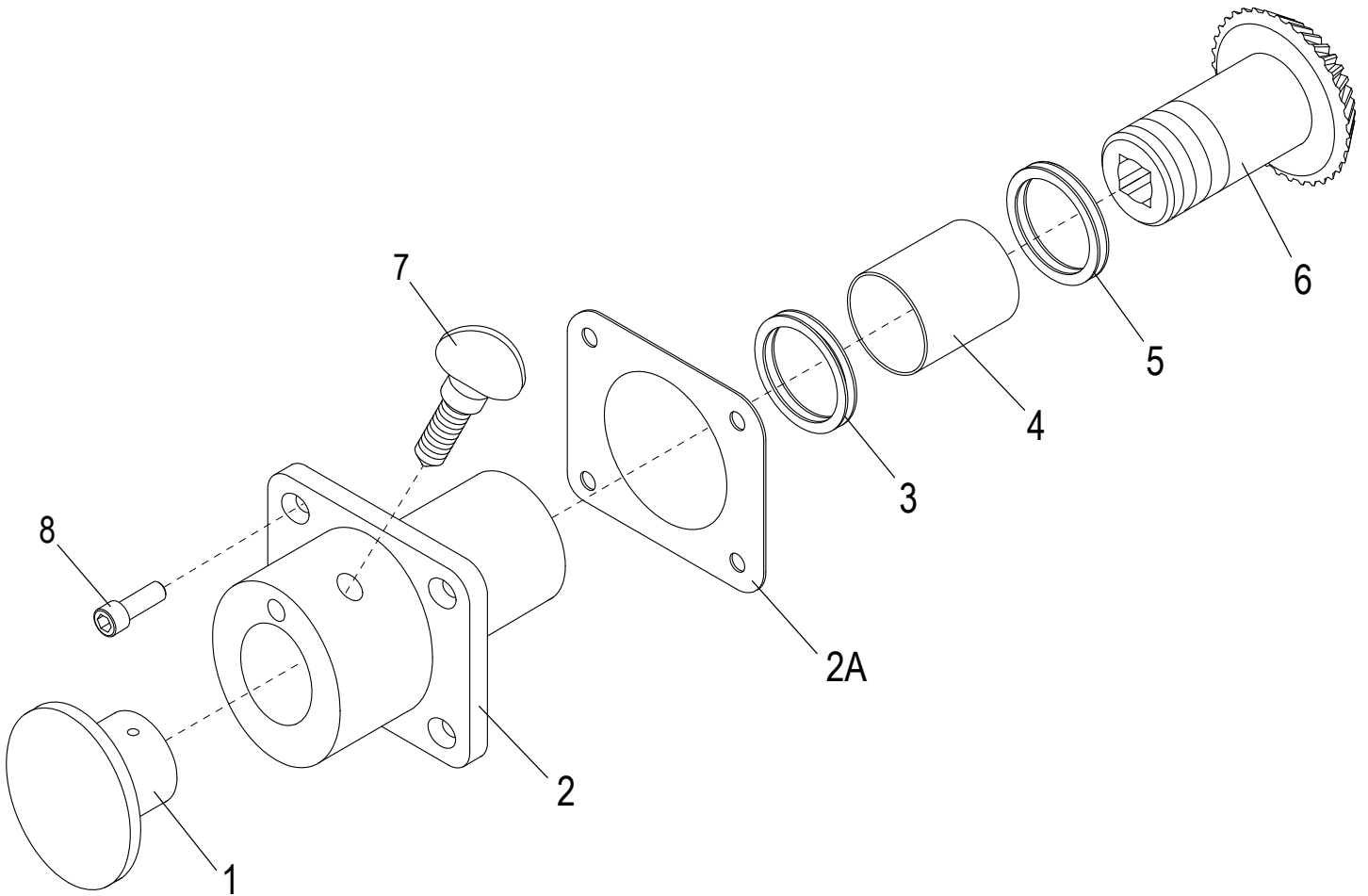



SP30E Hub Assembly Components

Item	Part Number	Description	Qty	Serial Number
1	X10007	Attachment Hole Plug	1	
2	X30017-DG	Attachment Hub	1	
2A		Gasket	1	
3	X10089	Oil 45x35x8mm Seal	1	
4	X10075	Bearing	1	
5	X30018-1	Thrust Washer ID-35mm, OD-55mm, TH-1mm	2	
6	X30014	Level Drive Gear (35T)	1	
7	X10005	Thumb Screw 1/2-13x3/4"	1	
8		Cap Screw M6x25 Socket Hd	4	



SP30E Planetary Components

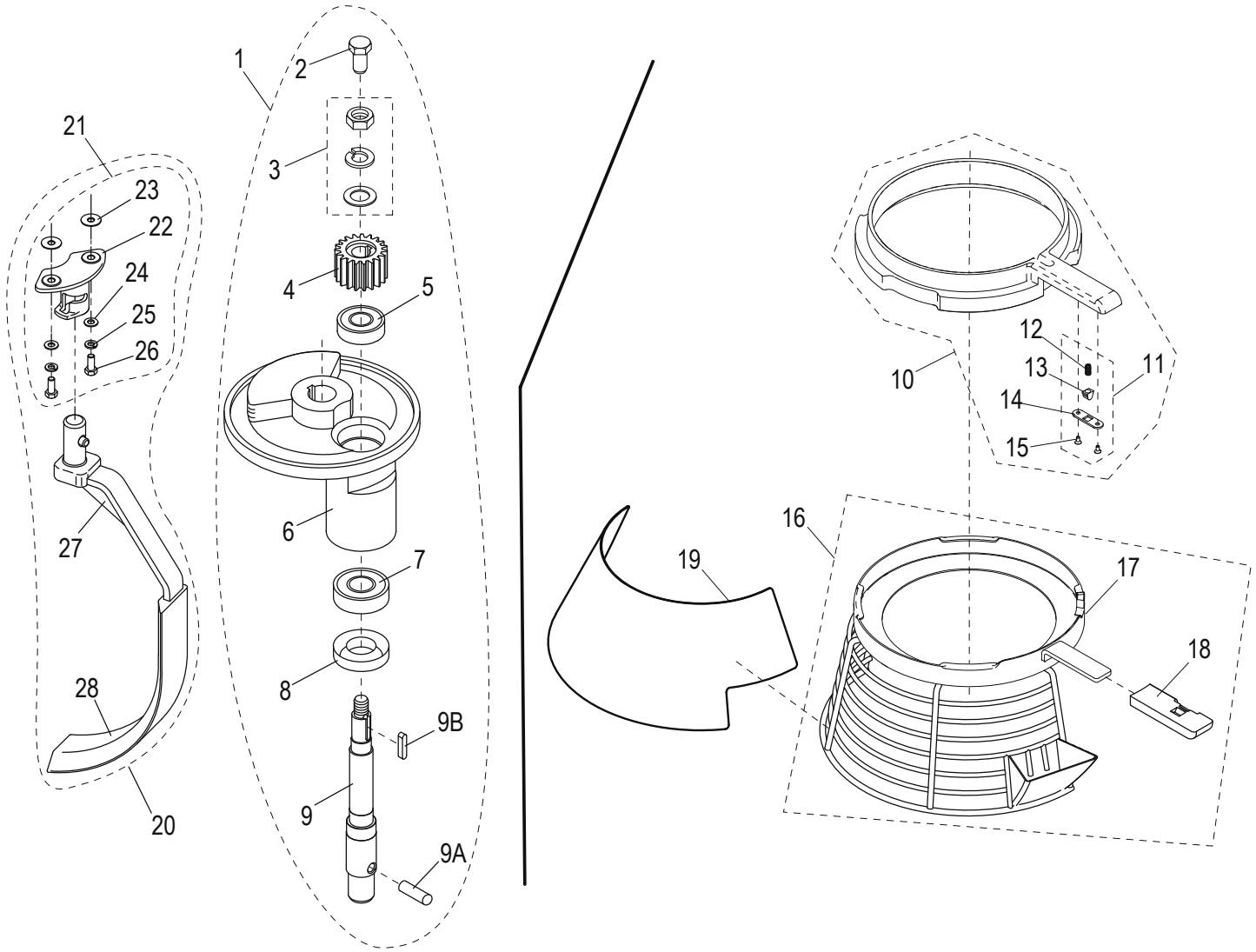



SP30E Planetary Components

Item	Part Number	Description	Qty	Serial Number
1	X30019-28	Complete Planetary Assembly (Incl. items 2-9B)	1	
2	X30019	Ext. Hex Hd Screw M10-1.5x25mm, B.O.	1	
3	X30020	Nut M14 Stop & Washers	1	
4	X30021	Pinion, Beater (21T)	1	
5	X10012	Ball Bearing	1	
6	X30023-DG	Planetary Shaft Holder	1	
7	X30024	Ball Bearing	1	
8	X30025	Oil Seal	1	
9	X30027	Planetary Shaft, External Thread (New Style)	1	
9A	X30028	Dowel Pin M12x17mm	1	
9B	X30026	Shaft Key 5x5x24mm	1	
10	X300S2	Plastic Slide Sheath, Removable Safety Guard (Incl. items 11-15)	1	
11	X200S3	Spring Plunger Hardware Kit	1	
12		Spring	1	
13		Plunger	1	
14		Plate, Plunger Retention	1	
15		Screw M3x8mm Flat Hd	2	
16	X300S1	Bowl Guard Assembly, Stainless Steel (Incl. items 17-18)	1	
17		Removable Bowl Guard	1	
18	X30504	Handle, Plastic - Removable Safety Guard	1	
19	X02624	Cover, Plastic	1	
20	XXSCRP-30	Bowl Scraper Assembly (Incl. items 21-28)	1	
21	X02000	Scraper Mounting Kit (Incl. items 22-26)	1	
22		Scraper Mounting Hub	1	
23		Washer	2	
24		Washer M8 Flat	2	
25		Washer M8 Split Lock	2	
26		Screw M8x25mm Hex Hd	2	
27		Scraper Arm	1	
28	X40515	Bowl Scraper	1	



SP30E Gearbox Components

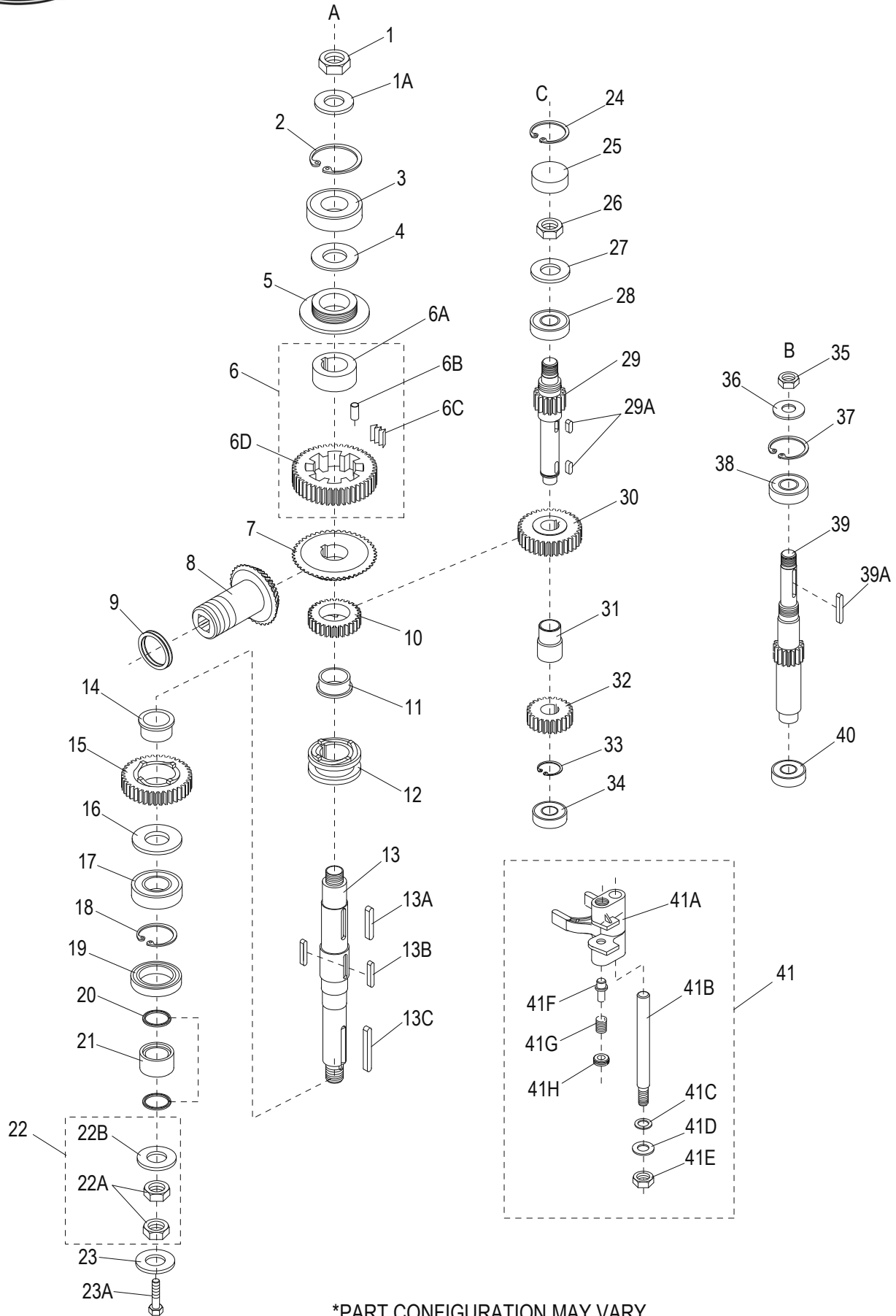

*PART CONFIGURATION MAY VARY.



SP30E Gearbox Components

Item	Part Number	Description	Qty	Serial Number
1	X30111	Thin Hex Nut M20-1.5, OD-29, HT-10mm, Zn	1	
1A	X30111A	Flat Washer M20, ID-21, OD-37, TH-3mm, SS	1	Part Config. May Vary
2	X30112	Retaining Ring STW-52	1	
3	X30024	Ball Bearing	1	
4		Shim	1	Part Config. May Vary
5	X30113	Lead-In Oil Pad	1	
6	X30114-117	Slow Speed Gear Assembly	1	(Incl. items 6A-6D)
6A		Bushing	1	
6B		Roller Pin	1	
6C		Slice Spring	1	
6D		Gear, Slow Speed (52T)	1	
7	X30118	Gear, Bevel (52T)	1	
8	X30014	Level Drive Gear (35T)	1	
9	X30018-1	Thrust Washer ID-35mm, OD-55mm, TH-1mm	1	
10	X30120-2	Gear, Clutch (35T) New Style	1	
11	X30119	Bushing, Clutch	1	
12	X30133	Sleeve, Clutch	1	
13	X30130	Drive Shaft	1	
13A	X30121	Key H-8xW-8xL-40mm Round Ends	1	
13B	X30132	Key H-8xW-10xL-40mm Round Ends	1	
13C	X30131	Key H-10xW-10xL-55mm Round Ends	1	
14	X30119	Bushing, Clutch	1	
15	X30122	Gear, Clutch (45T)	1	
16	X30124	Heel	1	
17	X80F10	Ball Bearing	1	
18	X30126	C-Ring Retaining Ring STW-72	1	
19	X30128	Oil Seal	1	
20	X30221	O-Ring 36x30x3mm	2	
21	X30127	Guard, Oil Bushing	1	
22	X30129C	Washer M20 Flat & Stop Nut	1	Part Config. May Vary
22A	X30111	Thin Hex Nut M20-1.5, OD-29, HT-10mm, Zn	2	Part Config. May Vary
22B	X30111A	Flat Washer M20, ID-21, OD-37, TH-3mm, SS	1	Part Config. May Vary
23	X30129B	Washer M8x25x1.8 Flat	1	Part Config. May Vary
23A	X30129A	Screw M8x12mm Hex Head	1	Part Config. May Vary
24	X25106	Int. Retaining Ring ID-2, G-2.122, OD-2.210, TH-0.062" B.O.	1	
25		Cap, Shaft	1	
26	X30147	Thin Hex Nut M16-1.5, OD-24, HT-8, Zn	1	
27		Washer M16	1	
28	X10012	Ball Bearing	1	
29	X30150-2	Transmission Shaft (13T) New Style, Splined	1	
29A	X30149	Key, Round Ends H-7xW-7xL-18mm	2	
30	X30148-2	Gear (30T) New Style	1	
31	X30144	Bushing, Spacer	1	
32	X30143-2	Gear (20T) New Style, Splined	1	
33	X30141	Retaining Ring STW-24	1	
34	X30140	Ball Bearing	1	
35	X30147	Thin Hex Nut M16-1.5, OD-24, HT-8, Zn	1	
36		Washer, Flat M16	1	
37	X30146	Int. Retaining Ring ID-1-3/4, Groove-1.858, OD-1.942, TH-0.062"	1	
38	X10012	Ball Bearing	1	
39	X30145	Shaft, Master (15T)	1	
39A	X30081	Shaft 5x5x30mm Key	1	
40	X30140	Ball Bearing	1	Part Config. May Vary



SP30E Gearbox Components

Item	Part Number	Description	Qty	Serial Number
41	X30134-139	Yoke Shifter Assembly (Incl. items 41A-41H)	1	
41A		Yoke Shifter	1	
41B		Guide, Rod Shifter	1	
41C	X01372	Lock Washer M12, ID-12.7, OD-21, TH-2.5mm, SS	2	
41D	X01370	Washer M12 Flat	2	
41E	X30215	Hex Nut M12-1.75, OD-19mm, HT-10mm, Zn	2	
41F		Plunger, Yoke Shifter	1	
41G		Spring, Yoke Shifter	1	
41H		Spring, Retainer	1	



INTENTIONALLY LEFT BLANK PAGE



SP30E Motor Components

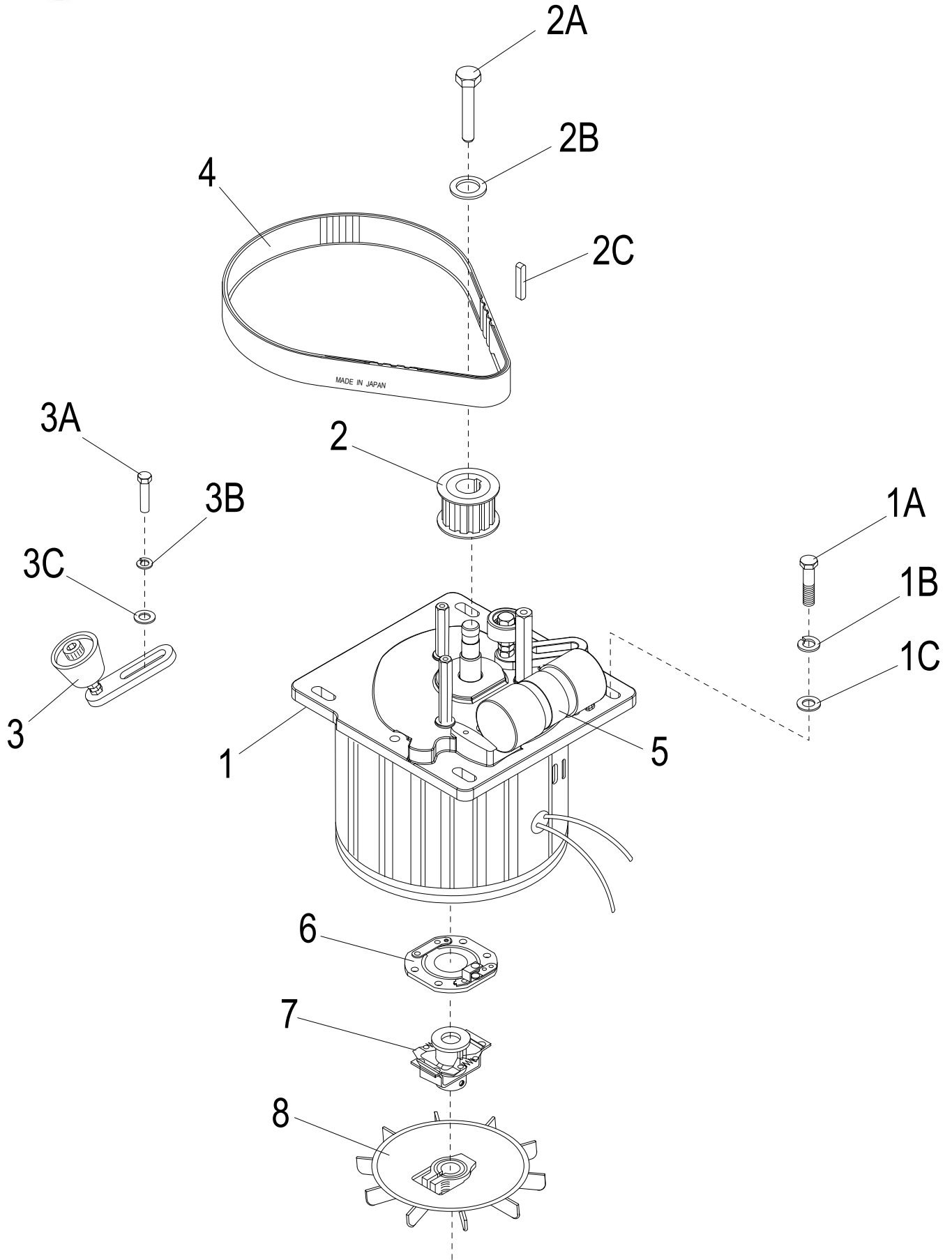



SP30E Motor Components

Item	Part Number	Description	Qty	Serial Number
1	X02511	Motor Assembly with Brake, 1HP 220/50/1	1	
1A	X30069	Screw M8x30mm Hex Hd	4	
2	X00734	Wheel, Motor Cog (20T) 50HZ	1	
2A	X30075	Ext. Hex Hd Screw M8-1.25x20mm, Zn	1	
2B	X30074	Flat Washer M8, ID-8, OD-24, TH-2mm, Zn	2	
2C	X40073	Key H-5xW-5xL-20mm Round Ends	1	
3	X30158	Belt Tensioner	1	
3A		Screw M8x24mm Hex Hd	2	
3B		Washer M8 Split Lock	2	
3C		Washer M8 Flat	2	
4	X30072-1	Cogged Belt (S8M-800)	1	
5	X30070-1	Capacitor, Start 400MF	1	
6	X10051	Switch, Platinum	1	
7	X02510	Clutch, 50Hz	1	
8	X30061	Cooling Fan	1	



SP30E Motor Brake Components

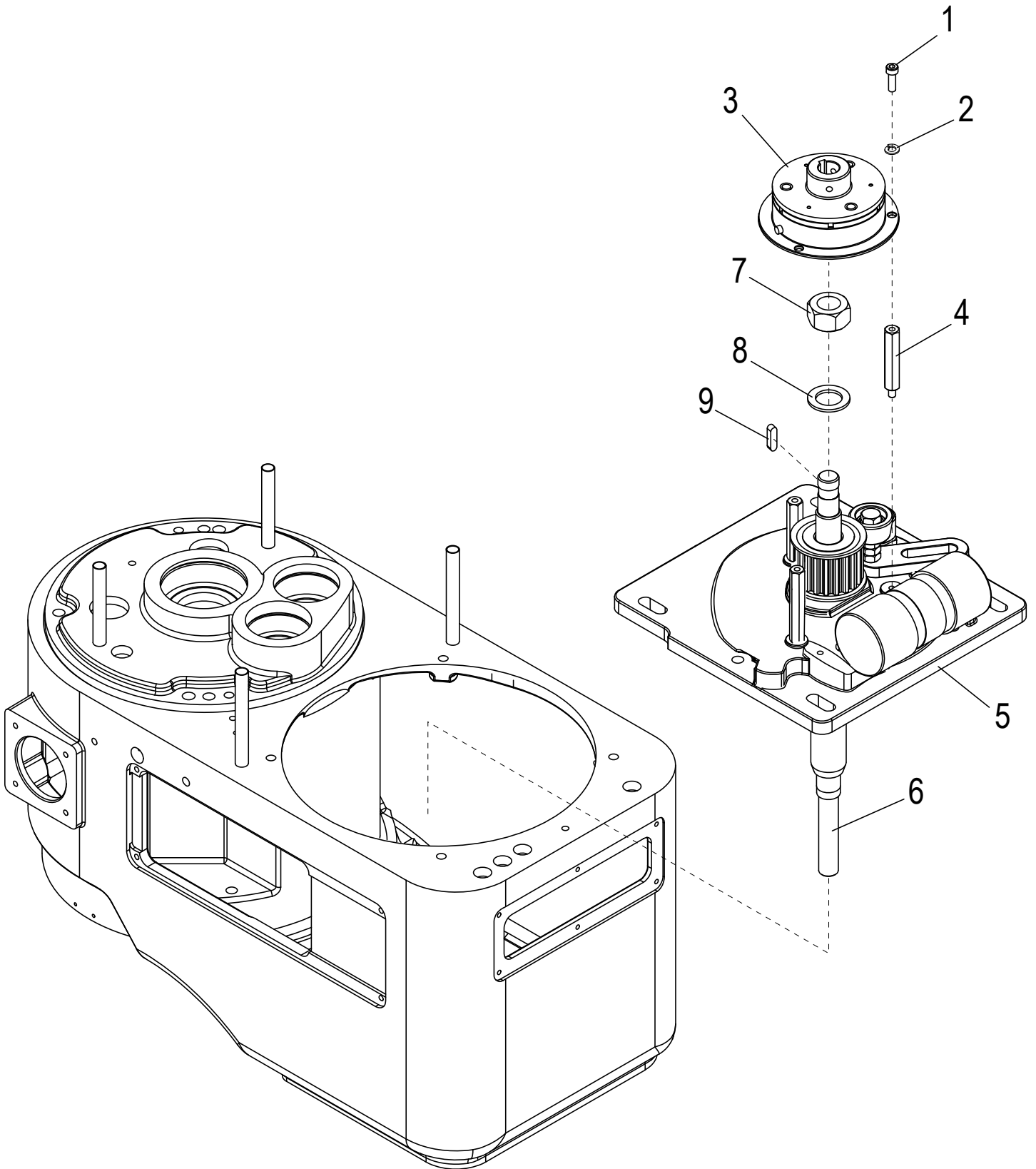



SP30E Motor Brake Components

Item	Part Number	Description	Qty	Serial Number
1		Screw M5x12mm Socket Hd	4	
2		Washer M8 Split Lock	1	
3	X30501	Motor Brake, Magnetic	1	
4	X30502	Hex Standoff	3	
5		Top Cover, Motor	1	
6		Motor Shaft	1	
7		Nut M18 Hex	1	
8		Washer M18 Flat	1	
9		Shaft Key 5x5x17mm	1	



SP30E Digital Components

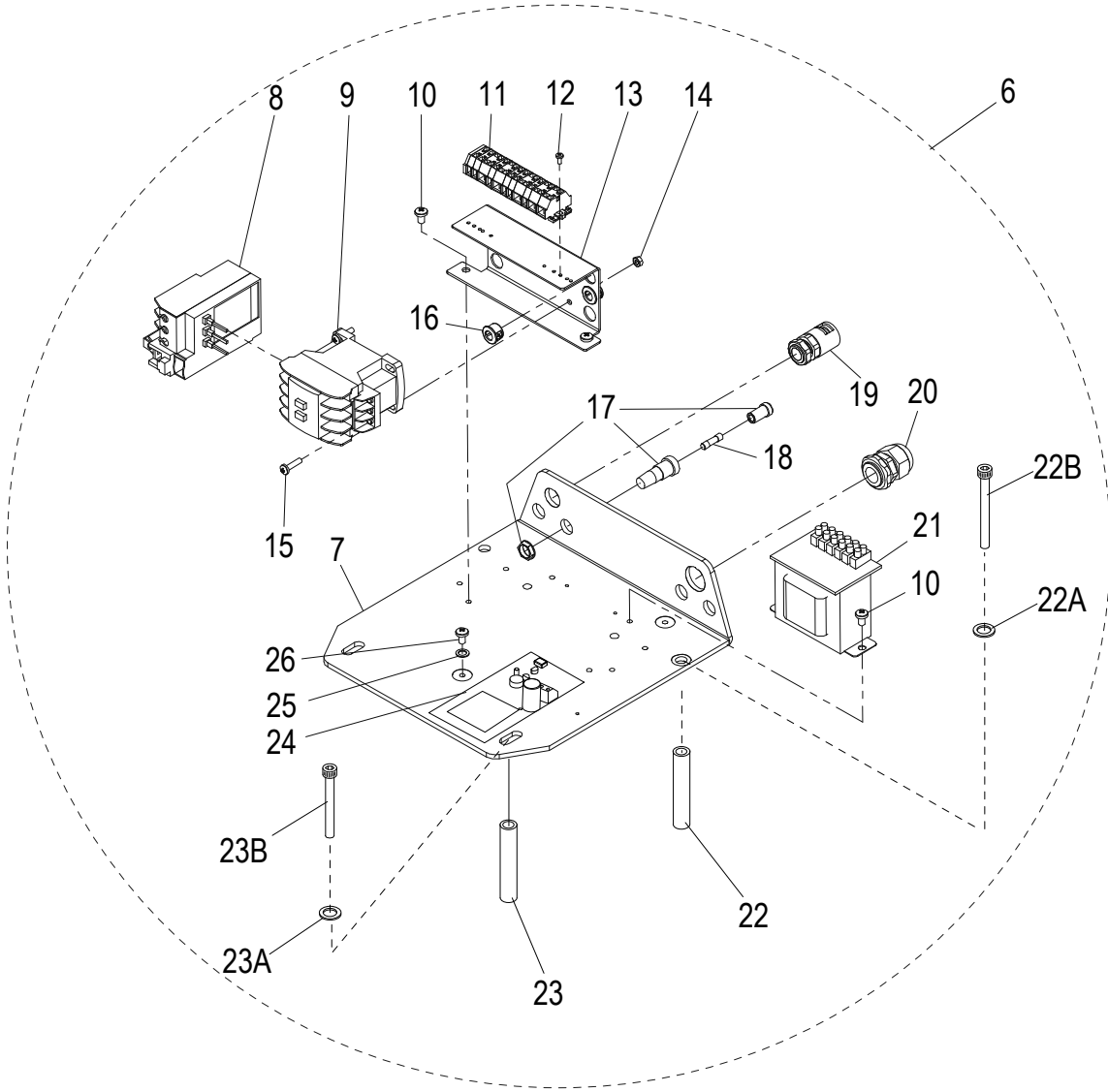
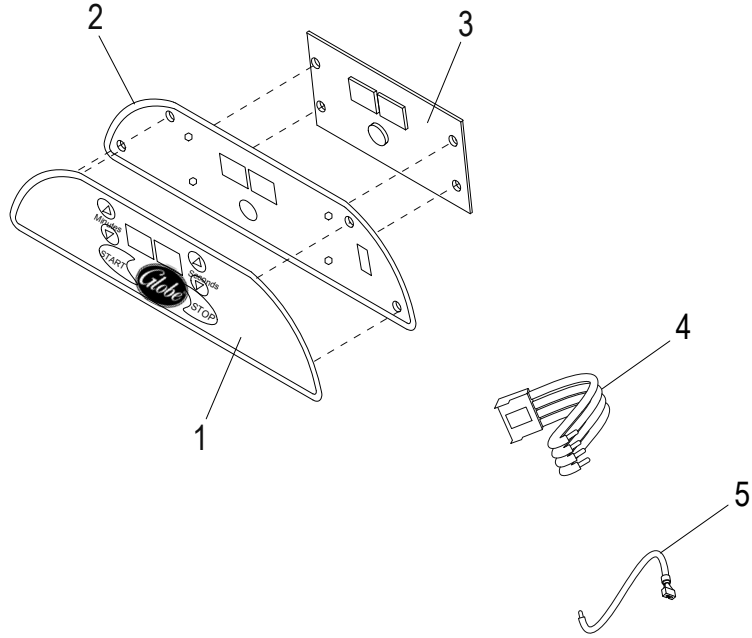



SP30E Digital Components

Item	Part Number	Description	Qty	Serial Number
1	X00566	Switch, Membrane	1	
2	X01337	Aluminum Panel	1	
3	X00568	Control Board	1	
4	X00675	4 Wire Harness With Connector	1	
5	X00676	Single Wire With Quick Connect	2	
6	X02519	Electronic Part Assembly, 220V-50Hz	1	(Incls. items 7-26)
7	X30013	Plate, Electronics Mounting	1	
8	X02529	Overload Relay	1	
9	X02530	Contact, 24V	1	
10	H02521	Cheese Hd Screw-Combo M5x8mm, Zn	4	
11	X02522	Block, Connecting	1	
12	H02523	Cheese Hd Screw-PHH M3x10mm, Zn	2	
13		Bracket, Mounting	1	
14	H02504	Hex Nut M4, OD-8mm, TH-3.5mm, Zn	2	
15	H02526	Cheese Hd Screw-PHH M4x15mm, Zn	2	
16	X02525	Cable Feed Through	2	
17	X02072	Fixture, Fuse	1	
18	X00570	Control Transformer Fuse	1	
19	X02527	Cable Feed Through	1	
20	X02528	Relief, Strain	1	
21	X02531	24V-15V Transformer, Control	1	
22	X30085	Tube M8x108mm Support	2	
22A		Washer M8 Flat	2	
22B	X30010	Socket Hd Cap Screw M8-1.25x90mm B.O.	2	
23	X30153	Tube, Support	2	
23A		Washer M8 Flat	2	
23B	X30086	Socket Hd Cap Screw M8-1.25x100mm, B.O.	2	
24	X02619	Brake Circuit	1	
25	H02532	Washer M5, OD-12, ID-5, TH-1mm, Zn	2	
26	H02533	Truss Hd Screw-Combo M5x8mm, Zn	2	



SP30E Wiring Diagram, Single Phase, Digital Timer

