

Parts Catalog



SP40E-380-400503

Mixer

Model: SP40E-380-400503

8/12/2019 Rev -
IMPORTANT!

TO EXPEDITE SHIPMENT OF PARTS, ALWAYS SPECIFY MODEL, REV,
PART NUMBER, AND SERIAL NUMBER OF UNIT.

GLOBE FOOD EQUIPMENT COMPANY

2215 East River Road
Dayton, Ohio 45439

Parts Department

Toll Free 1-800-745-6238 · Fax (937) 290-0585

E-Mail: info@globefoodequip.com

Website: www.globefoodequip.com

Not for resale

Table of Contents

Description	Page
SP40E Base Components	4
SP40E Head Components	8
SP40E Hub Assembly Components	12
SP40E Planetary Components	14
SP40E Gearbox Components	16
SP40E Motor Components	20
SP40E Motor Brake Components	22
SP40E Digital Components	24
SP40E Wiring Diagram, 380_420V_50-60HZ Three Phase	26



SP40E Base Components

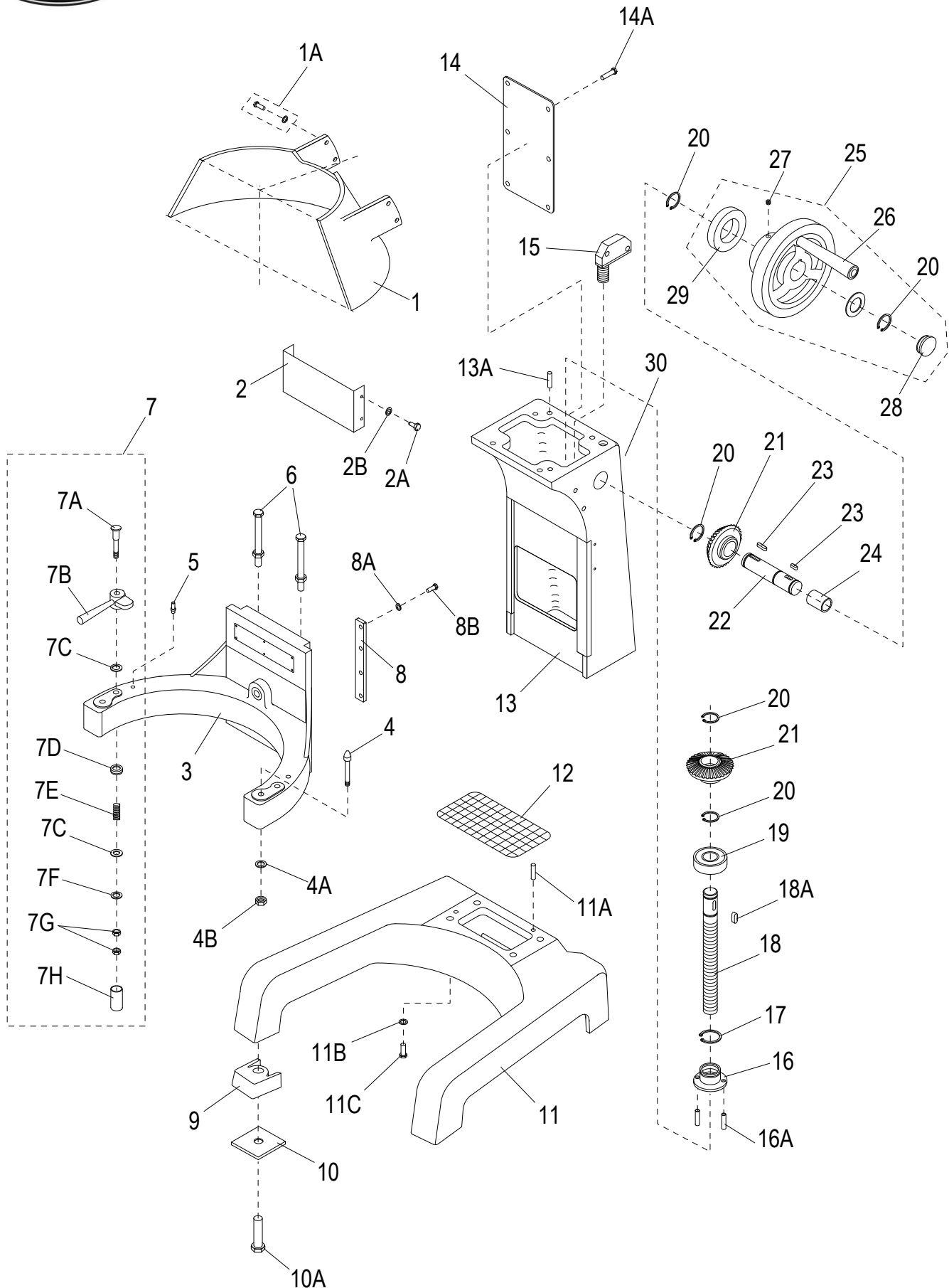



SP40E Base Components

Item	Part Number	Description	Qty	Serial Number
1	X40036	Guard, Rear	1	
1A	X30101	Hex Screw M8x20mm & Flat Washer	4	
2	X40102	Mixer Column Cover	1	
2A	X40056	Truss Hd Screw PHH M6-1.0x10mm, SS-18	3	
2B		Washer M6 Flat	3	
3	X40034	Bowl Cradle	1	
4	X40109	Dowel Screw Assembly	2	
4A	X01372	Lock Washer M12, ID-12.7, OD-21, TH-2.5mm, SS	2	
4B	X40110	Cap Nut, M12-1.75, OD-19mm, HT-22mm, Class 10, Zn	2	
5		Bowl Clamp Stop Pin	2	
6	X40106	Screw M10x54mm Hex Hd/Nut (Touch Shaft)	1	
7	X30033	Bowl Clamp Assembly (Set/2) (Incl. items 7A-7H)	1	
7A	X30108	Bowl Clamp Hardware Kit	2	
7B	X30033-2	Bowl Clamp (Set/2, New Style)	1	
7C		Washer M12 Flat	4	
7D		Hardware Cap Retainer	2	
7E		Spring	2	
7F		Washer M10 Split Lock	2	
7G		Nut M12 Acorn	4	
7H		Hardware Cap	2	
8	X40035	Cradle Slide Guides	2	
8A		Washer M8 Flat	8	
8B	X30197	Ext. Hex Hd Screw M8-1.25x25mm, SS	8	
9	X40162-163	Front/Rear Rubber Feet (Set)	1	
10		Shipping Washer (Incls. items 26-27)	4	
10A		Shipping Bolt 3/8x45mm	4	
10B	XXSEISMIC KIT-MD	Seismic Flange Kit (Not Shown)	1	
11	X40038-DG	Mixer Base	1	
11A	X40040	Dowel Pin Ø8x16mm Column Locator	2	
11B		Washer M12 Flat	4	
11C		Screw M12x40mm Hex Hd	4	
12	X40037	Base Screen	1	
13	X40042	Mixer Column	1	
13A	X30178	Dowel Pin Ø8x16mm Head Locator	2	
14	X40055	Plate, Rear Cover	1	
14A	X40056	Truss Hd Screw PHH M6-1.0x10mm, SS-18	6	
15	X30051	Microswitch, Bowl Lift	1	
16	X30104	Screw Sleeve	1	
16A	X30105	Roll Pin Ø4x30mm	1	
17	X25145	Retaining STW-35 Ring	1	
18	X40041	Bowl Lift Screw	1	
18A	X20123	Key, Round Ends H-5xW-5xL-18mm	1	
19	X30043	Ball Bearing	1	
20		Ext. Retaining Ring, OD-25, Groove-23.9, Ring ID-23.2, TH-1.2mm, B.O.	5	
21	X30045	Oblique Gear (30T)	2	
22	X40047	Shaft, Hand Wheel	1	
23	X40073	Key H-5xW-5xL-20mm Round Ends	2	
24	X40050	Oilless Bearing	1	
25	X40053M	Hand Wheel Crank With Handle, Metal	1	
26	X30053-1	Hand Wheel Crank Handle	1	
27		Set Screw M10x8mm Cup Pt. (Metal Wheel Only)	1	
28		Hand Wheel Cap	1	
29		Spacer (50m mod x 25.3mm Id x 10.2mm)	1	



SP40E Base Components

Item	Part Number	Description	Qty	Serial Number
30	X02595	United Kingdom, Hazardous Voltage LBL	(Not Shown)	1
30	X02594	Spanish, Hazardous Voltage LBL	(Not Shown)	1
30	X02593	Portuguese/Brazil Hazardous Voltage LBL	(Not Shown)	1
30	X02592	Thai, Hazardous Voltage LBL	(Not Shown)	1
30	X02591	Arabic, Hazardous Voltage LBL	(Not Shown)	1



INTENTIONALLY LEFT BLANK PAGE



SP40E Head Components

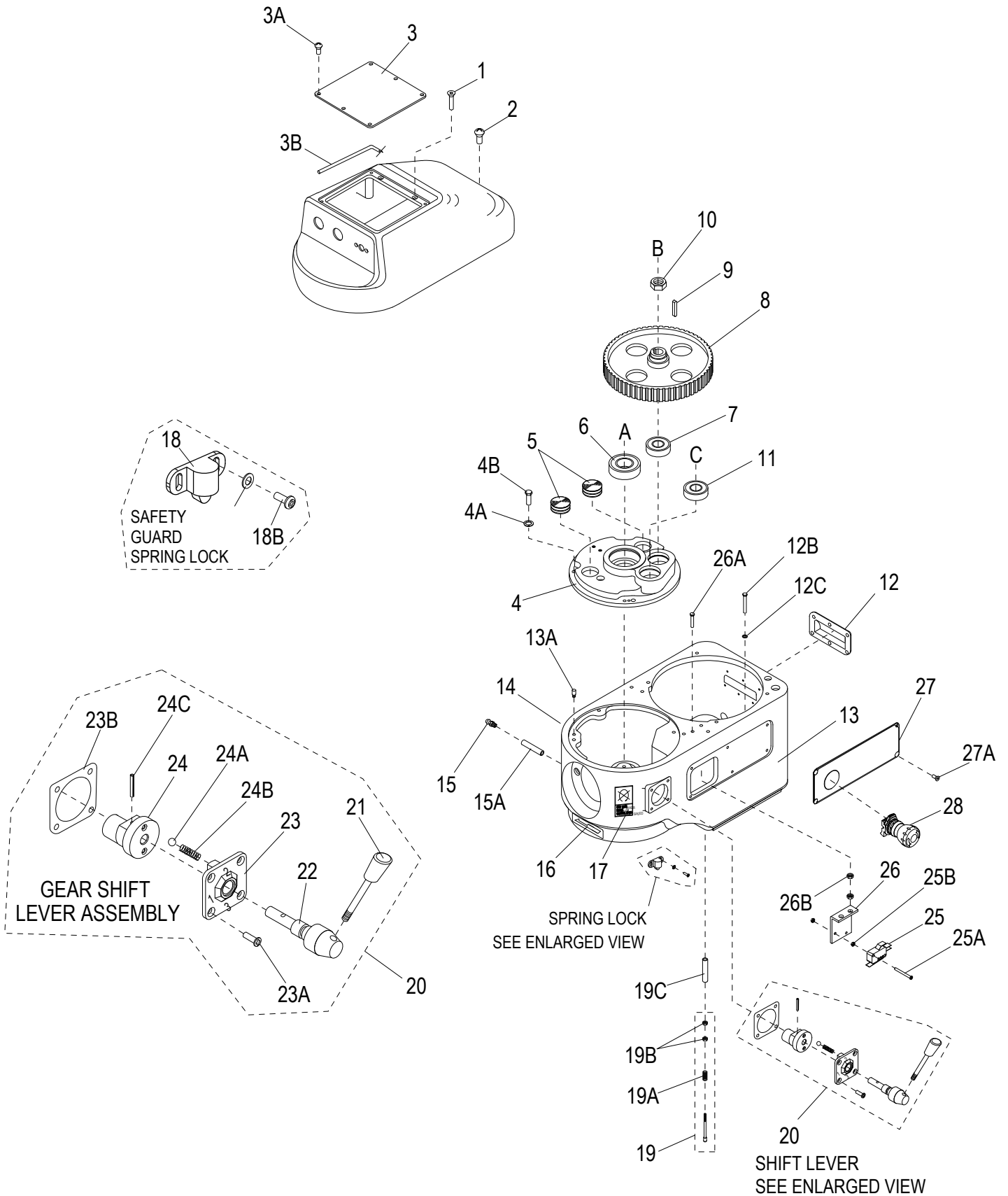



SP40E Head Components

Item	Part Number	Description	Qty	Serial Number
1	X30207	Flat Hd Screw-Socket M8-1.25x108mm, B.O.	2	
2	X30220	Flat Hd Screw-Socket M6-1.0x90mm, B.O.	1	
3	X40002	Cover, Switch Box	1	
3A	X40056	Truss Hd Screw PHH M6-1.0x10mm, SS-18	6	
3B	X40003	Gasket, Switch Box	1	
4	X40077	Cover, Gear Housing	1	
4A	X30198	Lock Washer M8, ID-8.5mm, OD-12.7mm, TH-2mm	4	
4B	X30197	Ext. Hex Hd Screw M8-1.25x25mm, SS	4	
5	X10073	Oil Plug	2	
6	X30024	Ball Bearing	1	
7	X10012	Ball Bearing	1	
8	X60080	Wheel, Main Cog (97T)	1	
9	X40081	Key H-5xW-5xL-12mm Round Ends	1	
10	X40082	Thin Hex Nut M18-1.5, OD-27, Thick-9mm, CLASS 04, Zn	1	
11	X10012	Ball Bearing	1	
12	X30076	Plate, Ventilation	1	
13	X40087-1	Transmission Case, Removable Bowl Guard	1	
13A		Pin, Locating	2	
14	X02580	United Kingdom, Maint. of Intern. Gear LBL	1	
14	X02579	Spanish, Maint. of Intern. Gear LBL	1	
14	X02578	Portuguese/Brazil, Maint. of Intern. Gear LBL	1	
14	X02577	Thai, Maint. of Intern. Gear LBL	1	
14	X02576	Arabic, Maint. of Intern. Gear LBL	1	
15	X10900	Grease Fitting	1	
15A	X10217	Grease Tube	1	
16	X91012	Label, Arrow	1	
17	X02585	United Kingdom, Avoid Gear Damage LBL	1	
17	X02584	Spanish, Avoid Gear Damage LBL	1	
17	X02583	Portuguese/Brazil, Avoid Gear Damage LBL	1	
17	X02582	Thai, Avoid Gear Damage LBL	1	
17	X02581	Arabic, Avoid Gear Damage LBL	1	
18	X10134	Safety Guard Spring Lock	1	
18A		Washer M3 Flat	2	
18B	X10134B	Round Hd Screw-PHH M3-0.5x8mm, SS-18	2	
19	X40096	Touch Shaft Assy, Brass	1	
19	X30096N	Touch Shaft, Nylon	1	
19A	X30095	Spring	1	
19B	X30186	Hex Nut M5-0.8 OD-8, TH-4mm, Zinc	2	
19C	X40187	Tube	1	
20	X40057-60	Gear Shift Lever Assembly (Incls. 18-21C)	1	
21	X30057-1	Knob, Gear Shift	1	
22		Shaft	1	
23		Cover	1	
23A	X30179	Flat Hd Screw-Socket M8-1.0x16mmHd, Zn	4	
23B	X30059-1	Gasket	1	
24		Shaft Bias	1	
24A		Roller	2	
24B		Spring	2	
24C		Roll Pin Ø5x28mm	1	
25	X10057	Microswitch, Interlock	1	
25A	854-2	Screw, Magnet Mounting	2	
25B	854-3	Nut, Magnet Mounting	4	
26	X30062	Bracket, Microswitch	1	



SP40E Head Components

Item	Part Number	Description	Qty	Serial Number
26A		Screw M6x20mm Hex Hd	2	
26B		Nut M6 Hex	4	
27	X02605	United Kingdom, Emergency Stop Panel LBL	1	
27	X02604	Spanish, Emergency Stop Panel LBL	1	
27	X02603	Portuguese/Brazil, Emergency Stop Panel LBL	1	
27	X02602	Thai, Emergency Stop Panel LBL	1	
27	X02601	Arabic, Emergency Stop Panel LBL	1	
27A	X30065	Truss Hd Screw-Phillips M5-0.8x10mm, SS	4	
28	X02515	Button, Emergency Stop	1	



INTENTIONALLY LEFT BLANK PAGE



SP40E Hub Assembly Components

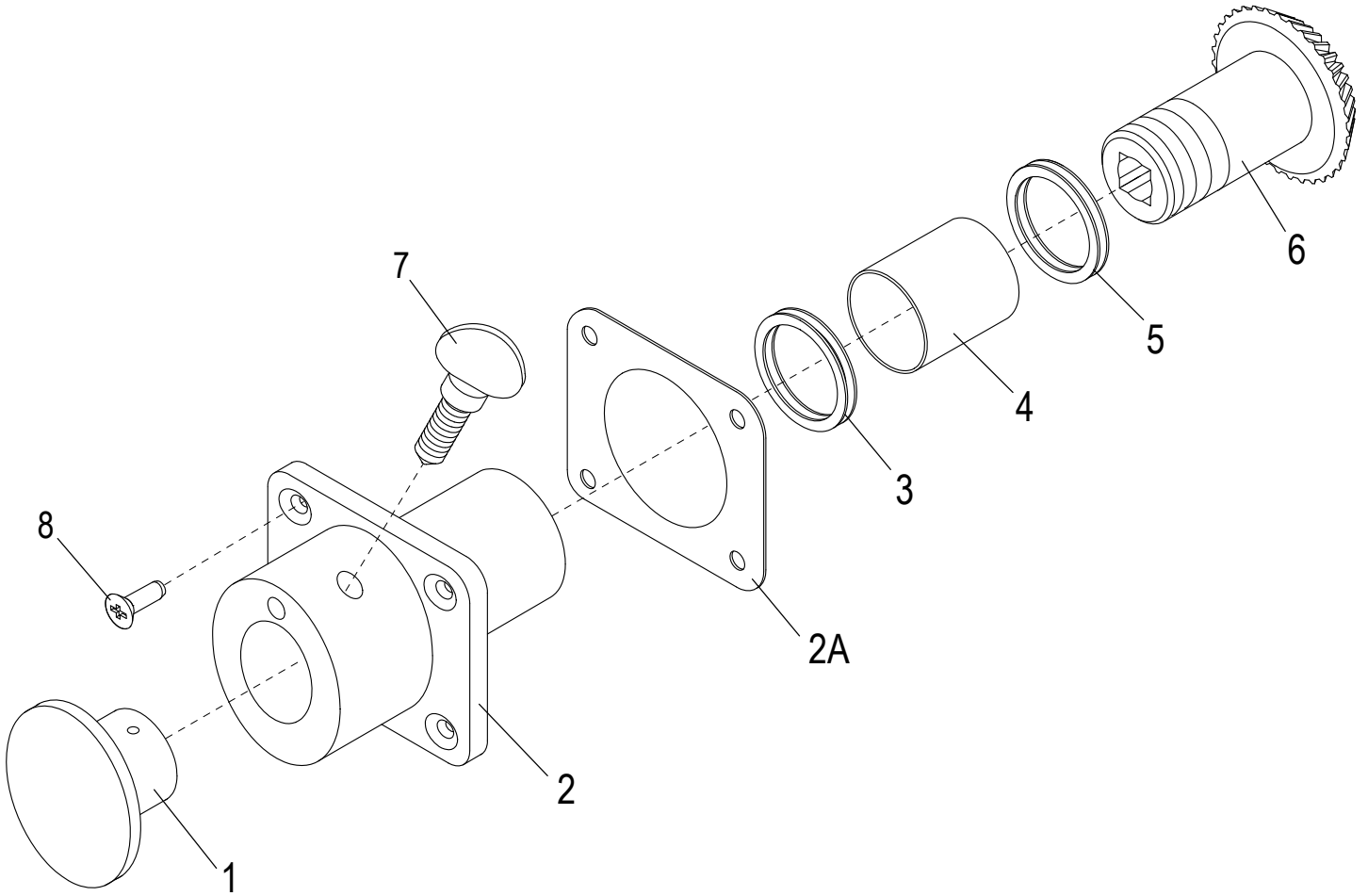



SP40E Hub Assembly Components

Item	Part Number	Description	Qty	Serial Number
1	X10007	Attachment Hole Plug	1	
2	X40017-DG	Attachment Hub	1	
2A		Gasket	1	
3	X10089	Oil 45x35x8mm Seal	1	
4	X10075	Bearing	1	
5	X30018-1	Thrust Washer ID-35mm, OD-55mm, TH-1mm	2	
6	X40014	Level Drive Gear (35T)	1	
7	X10005	Thumb Screw 1/2-13x3/4"	1	
8	X80B52	Socket Hd Cap Screw M6-1.0x20mm, B.O.	4	



SP40E Planetary Components

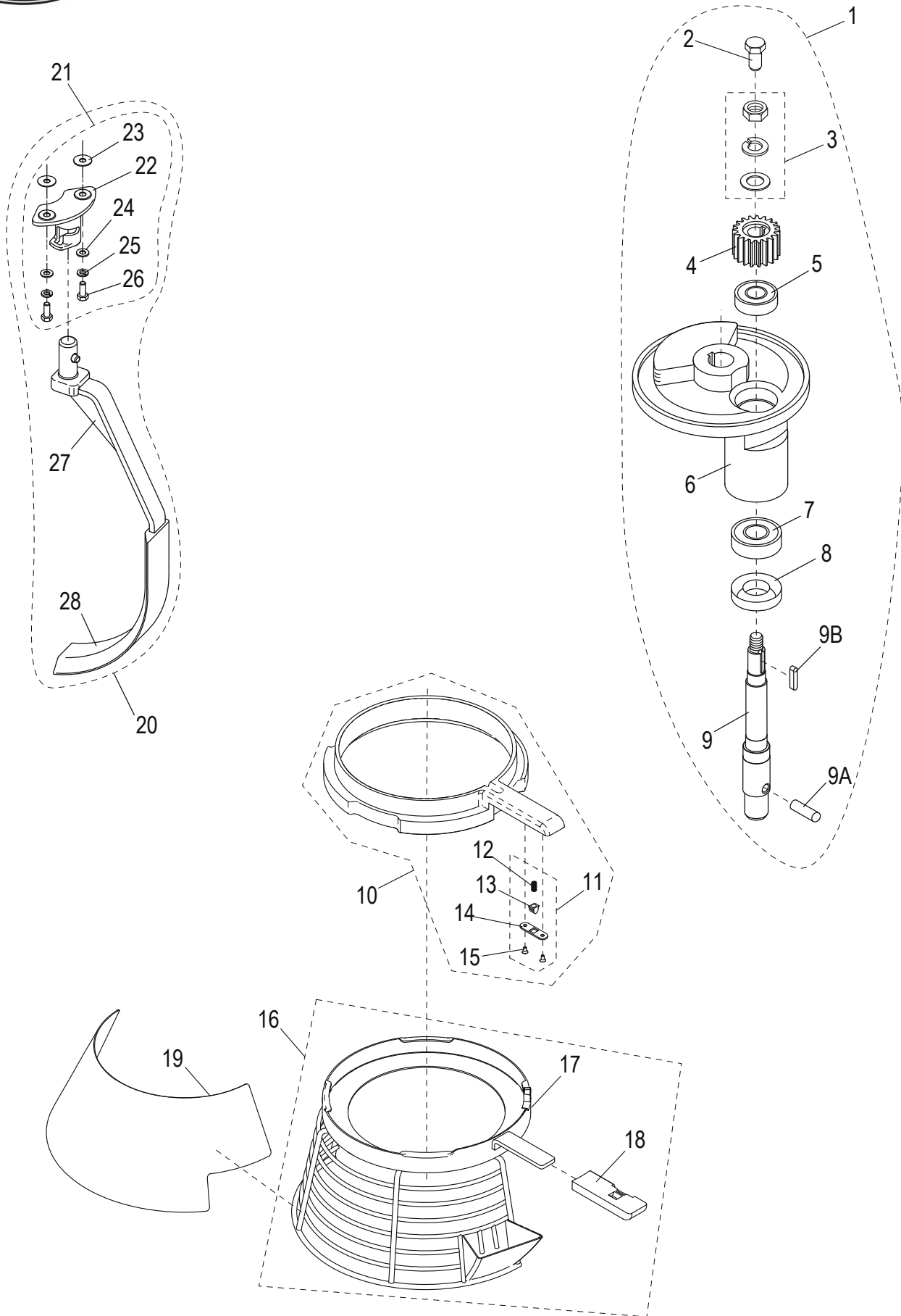



SP40E Planetary Components

Item	Part Number	Description	Qty	Serial Number
1	X40019-28	Complete Planetary Assembly (Incls. items 2-9B)	1	
2	X40019	Screw M10x24mm (Old Style Shaft)	1	
3	X30020	Nut M14 Stop & Washers	1	
4	X40021	Pinion, Beater (21T)	1	
5	X10102	Ball Bearing	1	
6	X40023-DG	Planetary Shaft Holder	1	
7	X30024	Ball Bearing	1	
8	X40025	Oil Seal	1	
9	X40027	Planetary Shaft, External Thread (New Style)	1	
9A	X30028	Dowel Pin M12x17mm	1	
9B	X40026	Key H-7xH-7xL23mm Round Ends	1	
10	X400S2	Plastic Slide Sheath, Removable Safety Guard (Incls. items 11-15)	1	
11	X200S3	Spring Plunger Hardware Kit	1	
12		Spring	1	
13		Plunger	1	
14		Plate, Plunger Retention	1	
15		Screw M3x8mm Flat Hd	2	
16	X400S1	Bowl Guard Assembly, Stainless Steel (Incls. items 17-18)	1	
17		Removable Bowl Guard	1	
18	X30504	Handle, Plastic - Removable Safety Guard	1	
19	X02625	Cover, Plastic	1	
20	X02000	Scraper Mounting Kit (Incls. items 21-28)	1	
21	XXSCRP-40	Bowl Scraper Assembly (Incls. items 22-26)	1	
22		Scraper Mounting Hub	1	
23		Washer	2	
24		Washer M8 Flat	2	
25		Washer M8 Split Lock	2	
26		Screw M8x25mm Hex Hd	2	
27		Scraper Arm	1	
28		Bowl Scraper	1	



SP40E Gearbox Components

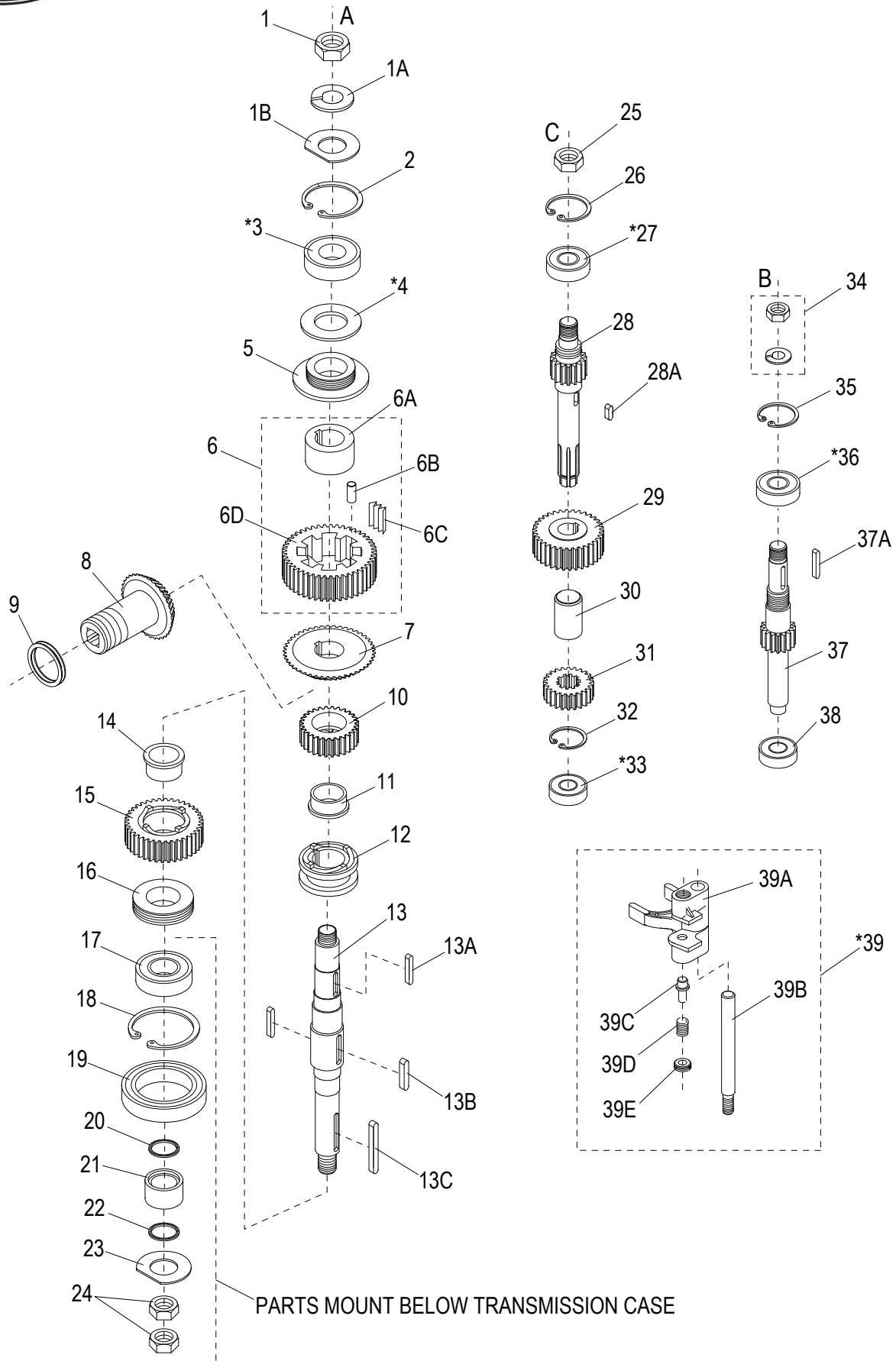

*PART CONFIGURATION MAY VARY.



SP40E Gearbox Components

Item	Part Number	Description	Qty	Serial Number
1	X40111	Nut M24 Jam	1	
1A	X40111A	Lock Washer M24, ID-25.5, OD-40, TH-5mm, Plain	1	
1B		Washer M24 Flat D Shape	1	
2	X30112	Retaining Ring STW-52	1	
3	X30024	Ball Bearing	1	
4		Shim	0	
5	X40113	Lead-In Oil Pad	1	
6	X40114-117	Slow Speed Gear Assembly (Incl. items 6A-6D)	1	
6A		Bushing	1	
6B		Dowel Ø8x16mm Pin	1	
6C		Slice Spring	1	
6D		Gear, Slow Speed (52T)	1	
7	X40118	Gear, Bevel (52T)	1	
8	X40014	Level Drive Gear (35T)	1	
9	X30018-1	Thrust Washer ID-35mm, OD-55mm, TH-1mm	1	
10	X40222	Gear, Clutch (34T) New Style	1	
11	X40119	Bushing, Clutch	1	
12	X30133	Sleeve, Clutch	1	
13	X40130	Drive Shaft	1	
13A	X40121	Key H-8xW-8xL-45mm Round Ends	1	
13B	X30121	Key H-8xW-8xL-40mm Round Ends	2	
13C	X30131	Key H-10xW-10xL-55mm Round Ends	1	
14	X40119	Bushing, Clutch	1	
15	X40122	Gear, Clutch (45T)	1	
16	X30124	Heel	1	
17	X40125	Ball Bearing	1	
18	X40126	Ext. Retaining Ring ID-3, G-3.182, OD-3.325, TH-0.093" B.O.	1	
19	X40128	Oil Seal	1	
20	X30221	O-Ring 36x30x3mm	1	
21	X40127	Guard, Oil Bushing	1	
22	X30221	O-Ring 36x30x3mm	1	
23		Washer M20 Flat D Shape	1	
24	X30111	Thin Hex Nut M20-1.5, OD-29, HT-10mm, Zn	2	
25	X40147	Nut, Stop	1	
26	X25106	Int. Retaining Ring ID-2, G-2.122, OD-2.210, TH-0.062" B.O.	1	
27	X10012	Ball Bearing	1	
28	X40150-2	Transmission Shaft (13T) New Style, Splined	1	
28A	X40149	Key H-8xW-8xL-24mm Round Ends	1	
29	X40223	Gear (31T) New Style	1	
30	X40144	Bushing, Spacer	1	
31	X40143-2	Gear (20T) New Style, Splined	1	
32	X40141	Retaining Ring STW-24	1	
33	X30140	Ball Bearing	1	
34	X40082	Thin Hex Nut M18-1.5, OD-27, Thick-9mm, CLASS 04, Zn	1	
35	X30146	Int. Retaining Ring ID-1-3/4, Groove-1.858, OD-1.942, TH-0.062"	1	
36	X10012	Ball Bearing	2	
37	X40224	Shaft, Master (13T)	1	
37A	X40081	Key H-5xW-5xL-12mm Round Ends	1	
38	X30140	Ball Bearing	1	
39	X40134-139	Yoke, Shifter Assembly (Incl. 39A-39E)	1	
39A		Yoke, Shifter	1	
39B		Guide, Rod Shifter	1	
39C		Plunger, Yoke Shifter	2	



SP40E Gearbox Components

Item	Part Number	Description	Qty	Serial Number
39D		Spring, Yoke Shifter	2	
39E		Spring, Retainer	2	



INTENTIONALLY LEFT BLANK PAGE



SP40E Motor Components

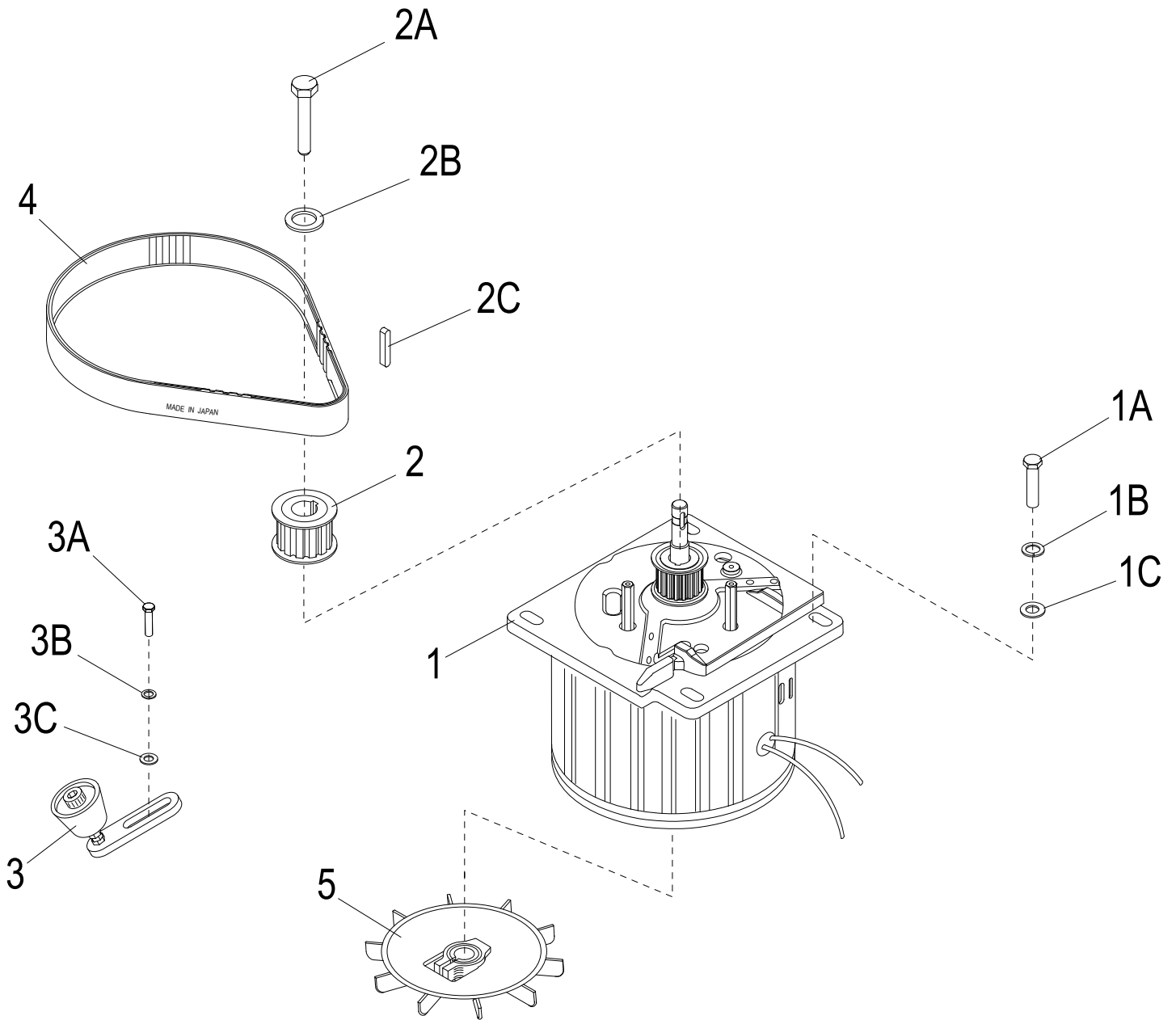



SP40E Motor Components

Item	Part Number	Description	Qty	Serial Number
1	X02674	Motor Assembly with Brake, 3HP 380-400/50/3	1	
1A	X40069	Screw M8x30mm Hex Hd	4	
1B	X08102	Lock Washer M8 ID-8.5, OD-14.8, TH-2mm Zn	4	
1C	X08076	Flat Washer, M8 ID-8.4mm, OD-16mm, TH-1.6mm, Zn	4	
2	X00734	Wheel, Motor Cog (20T) 50HZ	1	
2A	X08077	Ext. Hex Hd Screw M8-1.25x20mm, Zinc	1	
2B	X30074	Flat Washer M8, ID-8, OD-24, TH-2mm, Zn	2	
2C	X30073	Shaft Key 5x5x25	1	
3	X30158	Belt Tensioner	1	
3A	X40159	Screw M8x24mm Hex Head	2	
3B	X08102	Lock Washer M8 ID-8.5, OD-14.8, TH-2mm Zn	2	
3C	X08076	Flat Washer, M8 ID-8.4mm, OD-16mm, TH-1.6mm, Zn	2	
4	X40072-2	Cogged Belt (S8M-896)	1	
5	X40061	Cooling Fan	1	



SP40E Motor Brake Components

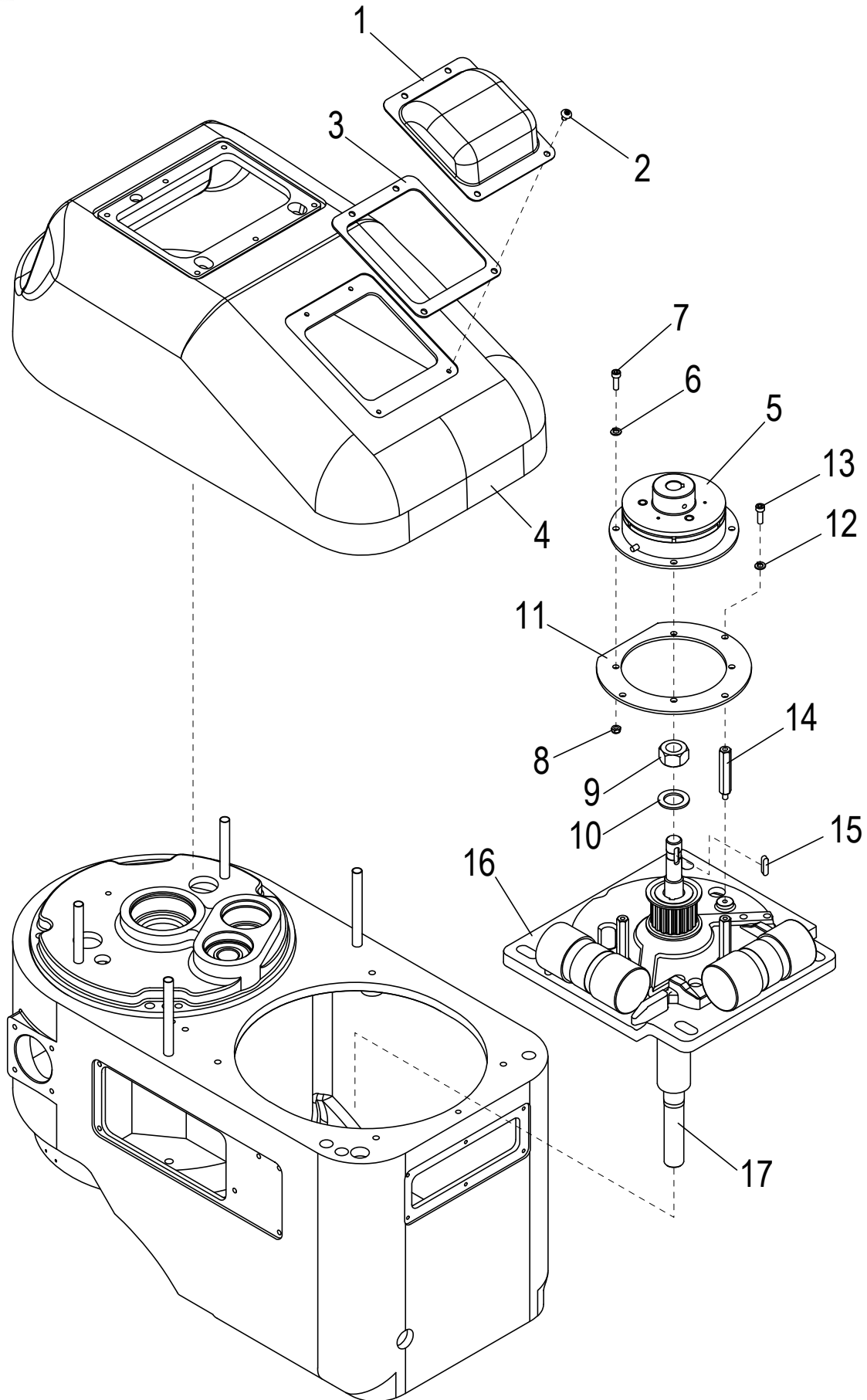



SP40E Motor Brake Components

Item	Part Number	Description	Qty	Serial Number
1	X25500	Cover, Motor Brake Components	1	
2		Screw M5x10mm Button Hd	4	
3	X25500-1	Gasket	1	
4	X40004-1-DG	Cover, Transmission	1	
5	X40501	Motor Brake, Magnetic	1	
6		Washer M5 Split Lock	4	
7		Cap Screw M5x12mm Socket Hd	4	
8		Nut M5 Hex	4	
9		Nut M18 Hex	1	
10		Washer M18 Flat	1	
11	X40500	Brake Housing	1	
12		Washer M5 Split Lock	3	
13		Screw M5x10mm Socket Hd	3	
14	X30502	Hex Standoff	3	
15		Shaft Key 5x5x17mm	1	
16		Top Cover, Motor (Incl. w/Motor Assembly)	1	
17		Motor Shaft (Incl. w/Motor Assembly)	1	



SP40E Digital Components

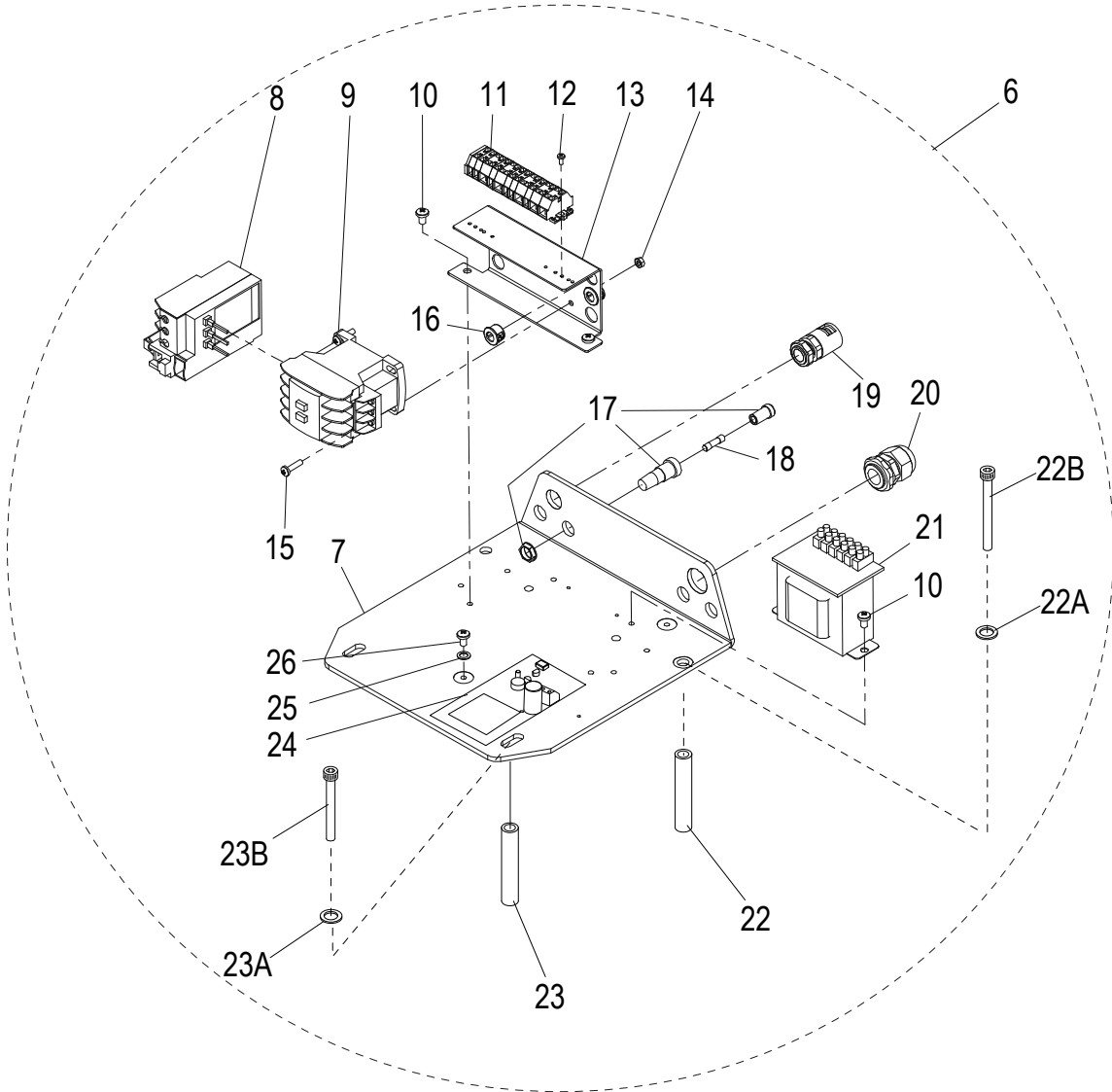
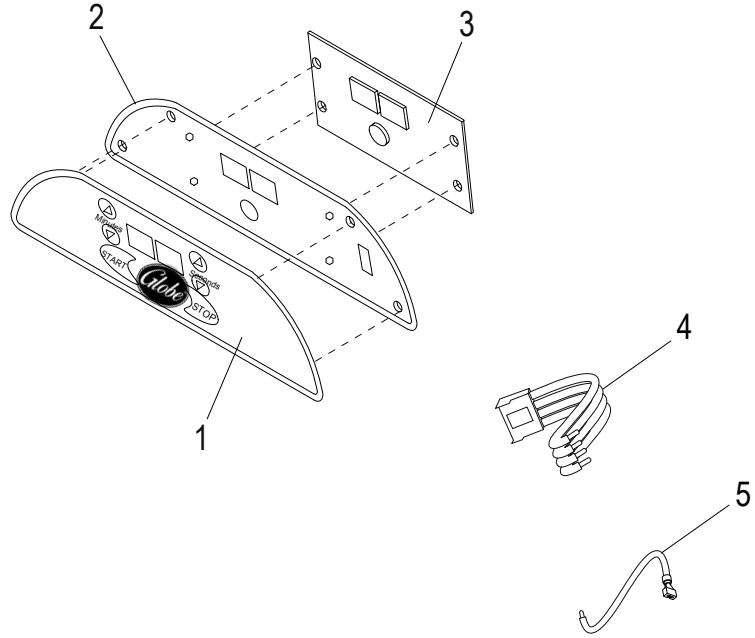



SP40E Digital Components

Item	Part Number	Description	Qty	Serial Number
1	X00567	Switch, Membrane	1	
2	X01338	Aluminum Panel	1	
3	X00568	Control Board	1	
4	X00675	4 Wire Harness With Connector	1	
5	X00676	Single Wire With Quick Connect	1	
6	X02675	Electronic Part Assembly (Incls. items 7-26)	1	
7	X60013	Plate, Electronics Mounting	1	
8	X40154-1ABB	Relay, Overload	1	
9	X02628	Contactora	1	
10	H02521	Cheese Hd Screw-Combo M5x8mm, Zn	4	
11	X02672	Block, Connecting	1	
12	H02523	Cheese Hd Screw-PHH M3x10mm, Zn	2	
13		Bracket, Mounting	1	
14	H02504	Hex Nut M4, OD-8mm, TH-3.5mm, Zn	2	
15	H02526	Cheese Hd Screw-PHH M4x15mm, Zn	2	
16	X02525	Cable Feed Through	2	
17	X02072	Fixture, Fuse	1	
18	X02073	Fuse	1	
19	X02527	Cable Feed Through	1	
20	X02528	Relief, Strain	1	
21	X02632	Transformer, Control	1	
22	X30085	Tube M8x108mm Support	2	
22A		Washer M8 Flat	2	
22B	X30010	Socket Hd Cap Screw M8-1.25x90mm B.O.	2	
23	X30153	Tube, Support	2	
23A		Washer M8 Flat	2	
23B	X30086	Socket Hd Cap Screw M8-1.25x100mm, B.O.	2	
24	X02619	Brake Circuit	1	
25	H02532	Washer M5, OD-12, ID-5, TH-1mm, Zn	2	
26	H02533	Truss Hd Screw-Combo M5x8mm, Zn	2	



SP40E Wiring Diagram, 380 420V 50-60HZ Three Phase

