

# Parts Catalog



**SP80PL**

## Mixer

**Model: SP80PL**

10/02/2019 Rev D

IMPORTANT!

TO EXPEDITE SHIPMENT OF PARTS, ALWAYS SPECIFY MODEL, REV,  
PART NUMBER, AND SERIAL NUMBER OF UNIT.

## **GLOBE FOOD EQUIPMENT COMPANY**

2215 East River Road  
Dayton, Ohio 45439

### **Parts Department**

Toll Free 1-800-745-6238 · Fax (937) 290-0585

E-Mail: [info@globefoodequip.com](mailto:info@globefoodequip.com)

Website: [www.globefoodequip.com](http://www.globefoodequip.com)

Not for resale



# Table of Contents

<b>Description</b>	<b>Page</b>
SP80PL Mixer Base	4
SP80PL Head and Hub Assembly	6
SP80PL Manual Lift Cradle Assembly	10
SP80PL Power Lift Cradle Assembly	14
SP80PL Gearbox Components	16
SP80PL Gear Shift Assembly	18
SP80PL Bowl Scraper Components	20
SP80PL Planetary Components	22
SP80PL Motor Components	26
SP80PL Manual Lift Controls	28
SP80PL Power Lift Controls	30
SP80PL Wiring Diagram, Manual Lift Mixer	34
SP80PL Wiring Diagram, Power Lift Mixer	35
SP80PL 3 PH 220V Power Lift Mixer Schematic	36
SP80PL Wiring Diagram, Power Lift Mixer-Digital Control Panel	37



# SP80PL Mixer Base

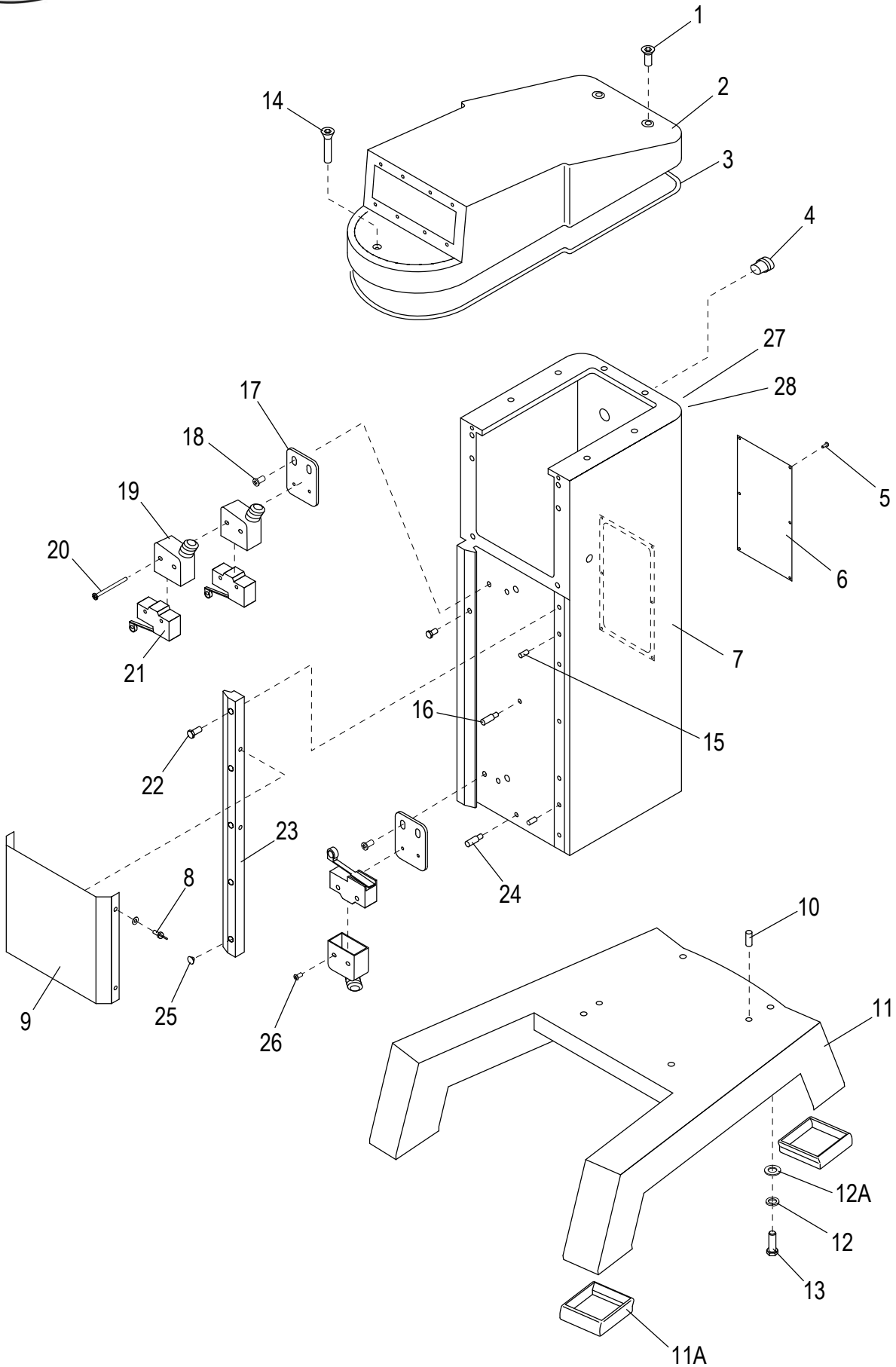



## SP80PL Mixer Base

Item	Part Number	Description	Qty	Serial Number
1	X80A01	Screw M8x85mm Flat Hd	2	
2	X80A02-DG	Cover, Transmission Case	1	
3	X62A03	Gasket	1	
4	X80A04	Strain Relief	1	
5	X80A05	Screw M5x12mm Truss Hd	6	
6	X80A06	Plate, Rear Column	1	
7		Mixer Column	1	
8	X80A08	Thumbscrew M5x12mm	4	
9	X80A09	Cover, Column Front	1	
10	X80A10	Dowel Pin Ø10x34mm	2	
11	X80A11-DG	Mixer Base	1	
11A	X80A11-1	Rubber Feet Set (Front/Rear)	1	
12	X80A12	Washer M14 Split Lock	4	
12A	X80A12-1	Washer M14 Flat	4	
13	X80A13	Screw M14x50mm Hex Hd	4	
14	X80A01	Screw M8x85mm Flat Hd	1	
15	X80A15	Dowel Pin Ø10x33mm	2	
16	X80A16	Dowel Pin, Threaded	1	
17	X30216	Bracket, Microswitch Mounting	2	
18	X80A18	Screw M5x12mm Truss Hd	4	
19	X80E17	Microswitch Cover	3	
20	X80A20	Screw M4x45mm Hex Hd & Flat Washer	2	
21	X30219	Microswitch, Bowl Lift	3	
22	X80A22	Screw M12x25mm Hex Hd & Flat Washer	5	
23	X80A23	Slide, Front Bowl, Right (Cast Iron)	1	
23	X80A23-1	Slide, Front Bowl, Left (Metal Sheet)	1	7810150 ->
24	X80A24	Dowel Pin, Threaded	1	
25		Plug, Plastic	5	
26	X80A37	Screw M4x25mm Pan Hd & Flat Washer	2	
27	X91014	Label, Hazardous Voltage	1	
28	X91011	Label, Caution - 3 Phase	1	



# SP80PL Head and Hub Assembly

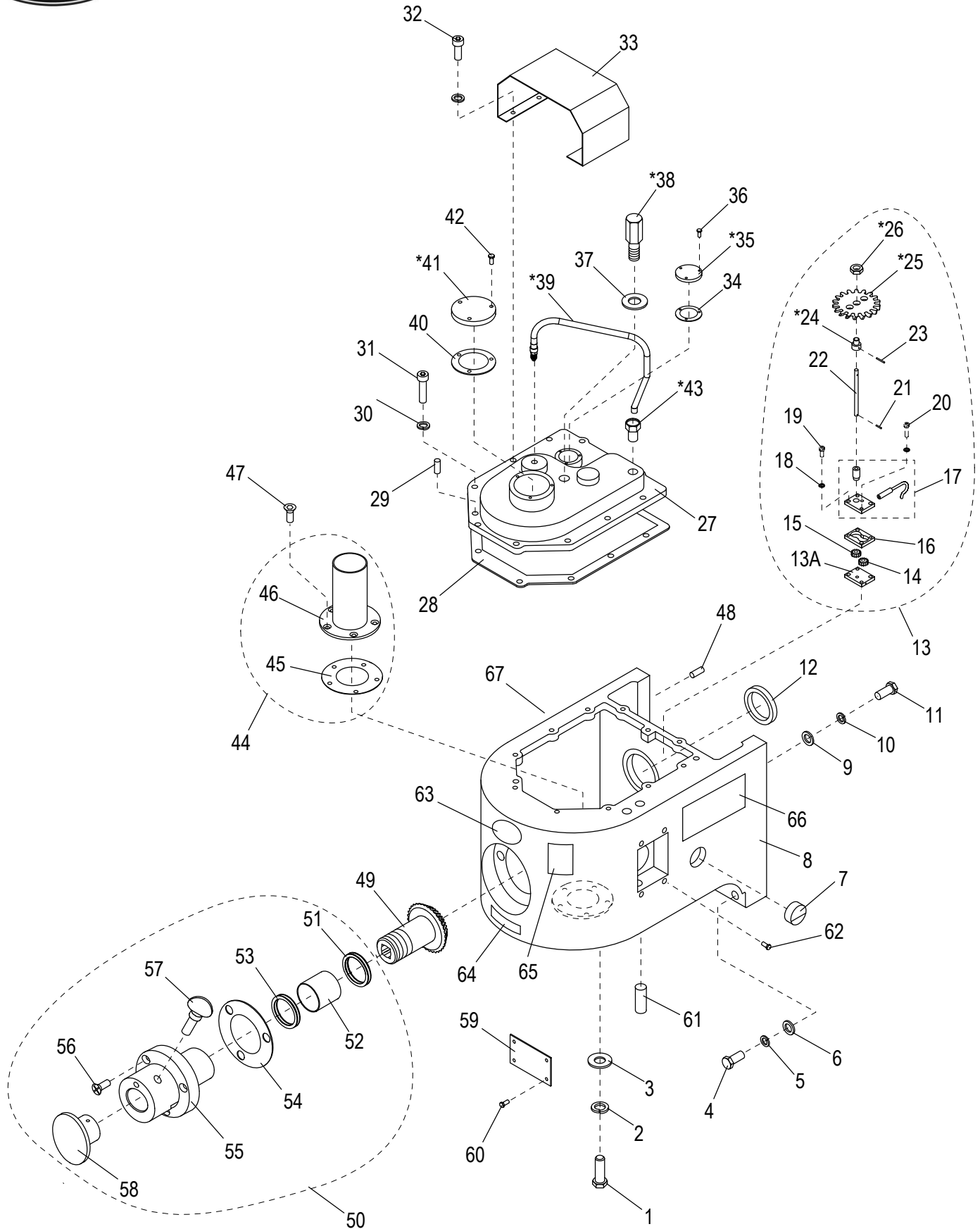

\*Part configuration may vary.



## SP80PL Head and Hub Assembly

Item	Part Number	Description	Qty	Serial Number
1	X80B01	Screw M10x15mm Hex Hd	1	
2	X80B02	Washer M10 Split Lock	1	
3	X80B03	Washer M10 Flat	1	
4	X80B04	Ext. Hex Hd Screw M12-1.75x40mm, B.O.	2	
5	X80B05	Lock Washer M12, ID-12.7, OD-21.1, TH-2.5mm, SS	2	
6	X80B06	Washer M12 Flat	2	
7	X80B07	Gauge, Oil Level	1	
8	X80B08	Transmission Case	1	
9	X80B09	Washer M12 Flat	6	
10	X80B10	Washer M12 Split Lock	6	
11	X80B11	Screw M12x60mm Hex Hd	6	
12	X80B12	Oil Seal TC50x80x10	1	
13	X80B13-27	Oil Pump Assembly	1	
13A		Plate, Oil Pump - Bottom	1	
14		Gear, Oil Pump, Right (15T)	1	
15		Gear, Oil Pump, Left (15T)	1	
16		Gear Set Pump	1	
17	X80B17-19	Housing & Tube Assy	1	
17		Pump Outlet Bronze Pipe	1	
17		Pump Shaft Bushing	1	
18	X80B26	Washer M5 Split Lock	4	
19	X80B27	Screw M5x15mm Socket Hd	2	
20		Cap Screw M5x25mm Socket Hd	2	
21		Roll Pin Ø2x10mm	1	
22		Shaft, Oil Pump	1	
23		Roll Pin Ø2x18mm	1	
24		Conveying Gear Assembly (29T)	1	
25	X80B24	Conveying Gear (29T)	1	
26		Jam Nut M12	1	
27	X80B25	Cover, Transmission Case	1	
28	X80B40	Gasket, Transmission Cover	1	
29	X80B39	Dowel Pin, Threaded	2	
30	X30198	Lock Washer M8, ID-8.5mm, OD-12.7mm, TH-2mm	11	
31	X30197	Ext. Hex Hd Screw M8-1.25x25mm, SS	9	
32	X30099	Socket Hd Cap Screw M8-1.25x35mm, B. O.	2	
33	X80B33	Top Cover	1	
34	X80B28	Gasket, Transmission Shaft Bearing Retainer	1	
35	X80B29	Bearing Retainer, Transmission Shaft	1	
36	X80B30	Screw M5x15mm Hex Hd	3	
37	X80B31	Washer M20 Flat	1	
38	X80B32	Oil Fill Plug (Screw M20x40mm Hex Hd)	1	
39	X00703	Hose Assembly	1	
39		Grease Fitting	1	
39		Hose Clamp	1	
40	X80B36	Gasket, Drive Shaft Bearing Retainer	1	
41	X80B35	Bearing Retainer, Drive Shaft	1	
42	X80B34	Screw M4x14mm Truss Hd	3	
43	X00704	Oil Fill Fitting	1	
44	X80B42-43	Oil Tube & Gasket Assembly	1	
45		Gasket, Lube Overflow Cylinder	1	
46		Lube Overflow Cylinder	1	
47	X80B41	Screw M6x15mm Flat Hd	5	
48	X80B56	Dowel Pin Ø10x20mm	2	



## SP80PL Head and Hub Assembly

---

Item	Part Number	Description	Qty	Serial Number
49	X80B44	Level Drive Gear (16T)	1	
50	X80B45-52	Hub Attachment Assembly	1	
51	X80B45	Thrust Washer	As Required	1
52	X10075	Bearing	2	
53	X10089	Oil 45x35x8mm Seal	1	
54	X80B48	Gasket, Attachment Hub	1	
55	X80B50-DG	Hub, Attachment	1	
56	X80B52	Socket Hd Cap Screw M6-1.0x20mm, B.O.	3	
57	X10005	Thumb Screw 1/2-13x3/4"	1	
58	X80B51	Hole Plug, Attachment	1	
59	X80B53	Cover Plate, Transmission	1	
60	X80B54	Screw M5x10mm Hex Hd	4	
61	X80B55	Dowel Pin	1	
62	X80E09	Screw M8x25mm Socket Hd	4	
63	871-3	Label, Globe Logo	1	
64	X91012	Label, Arrow	1	
65	X91010	Label, Stop To Chg Gears	1	
66	X91015	Label, Warning	1	
67	X91007-F	Label, Warning, French (Canada Only)	1	





*INTENTIONALLY LEFT BLANK PAGE*



# SP80PL Manual Lift Cradle Assembly

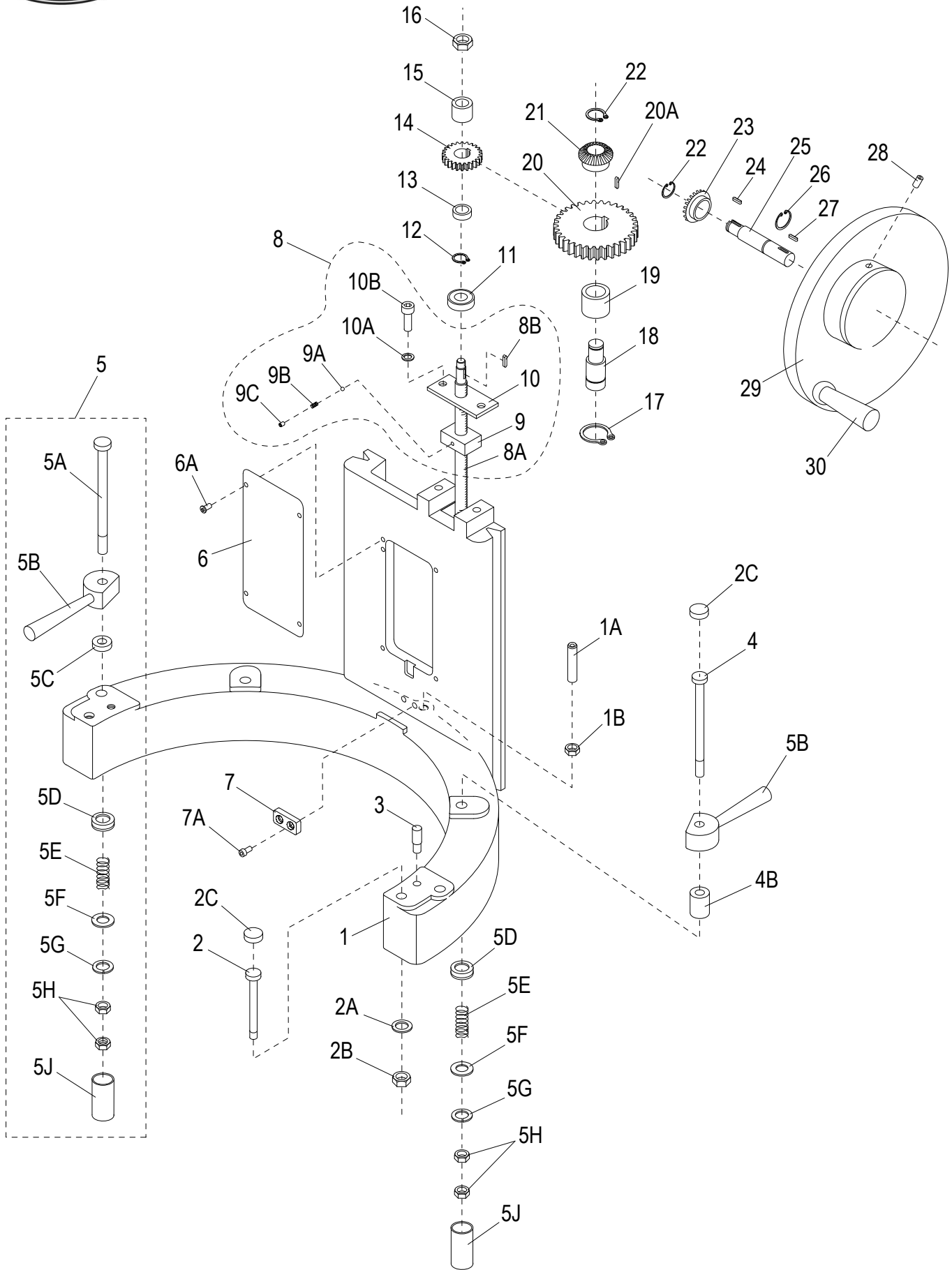



## SP80PL Manual Lift Cradle Assembly

Item	Part Number	Description	Qty	Serial Number
1	X80C12	Bowl Cradle	1	
1A		Set Screw M12x80mm Socket Hd - Cup Pt.	1	
1B		Nut M12 Hex	1	
2	X80C13	Bowl Locating Assembly	2	
2A	X80C11	Washer M12 Split Lock	2	
2B	X80C10	Nut M12 Acorn	2	
2C		Screw Cover	4	
3	X80C14	Dowel Pin, Threaded	2	
4	X80C09	Screw, Bowl Clamp - Rear	2	
4B	X80C07	Bushing, Bronze - Rear Clamp	2	
5	X80C05	Bowl Clamp Assembly (Set/2)	2	
5A	X80C06	Bowl Clamp Screw	2	
5B	X80C05-1	Bowl Clamp (Set/2)	4	
5C	X80C04	Bronze Bushing, Front	2	
5D		Hardware Cap Retainer	4	
5E	X80C03	Spring	4	
5F	X80B09	Washer M12 Flat	4	
5G		Washer M12 Split Lock	4	
5H	X80C01	Nut M12 Jam	4	
5J		Hardware Cap	4	
6	X80C17	Front Cover, Bowl Cradle	1	
6A	X80C18	Screw M5x10mm Hex Hd	4	
7	X80C16	Locking Bracket	1	
7A	X80C15	Screw M8x35mm Socket Hd & Lock Washer	2	
8	X80C19-24	Bowl Raise Screw Assembly	1	
8A		Bowl Raise Screw	1	
8B	X80H55	Shaft Key 6x6x25mm	2	
9		Nut, Bowl Lift	1	
9A		Roller	1	
9B		Spring	1	
9C		Set Screw M6x5mm Socket Hd - Cup Pt.	1	
10		Nut Mounting Plate	1	
10A		Washer M10 Split Lock	1	
10B		Screw M10x20mm Socket Hd	2	
11	X08114	Ball Bearing	1	
12	X80C26	Retaining Ring RTW40	1	
13	X80C27	Bronze Bushing, Lower	1	
14	X80C28	Oblique Gear (31T)	1	
15	X80C29	Bronze Bushing, Upper	1	
16		Nut M16 Hex	1	
17	X80C32	Retaining Ring STW-25	1	
18	X80C33	Drive Shaft	1	
19	X80C34	Oblique Shaft Sleeve	1	
20	X80C35	Oblique Gear (41T)	1	
20A	X80C36	Shaft Key 3x3x12mm	1	
21	X80C37	Gear, Male (23T)	1	
22	X80C38	Retaining Ring STW-19	3	
23	X80C40	Gear, Female (23T)	1	
24	X80C41	Shaft Key 5x5x18mm	1	
25	X80C42	Hand Wheel Shaft	1	
26	X80C38	Retaining Ring STW-19	1	
27	X80C44	Shaft Key 5x5x25mm	1	
28	X80C45	Set Screw M8x16mm Socket Head - Cup Pt	1	



## SP80PL Manual Lift Cradle Assembly

---

Item	Part Number	Description	Qty	Serial Number
29	X80C46	Hand Wheel	1	
30	X80C47	Handle	1	



*INTENTIONALLY LEFT BLANK PAGE*



# SP80PL Power Lift Cradle Assembly

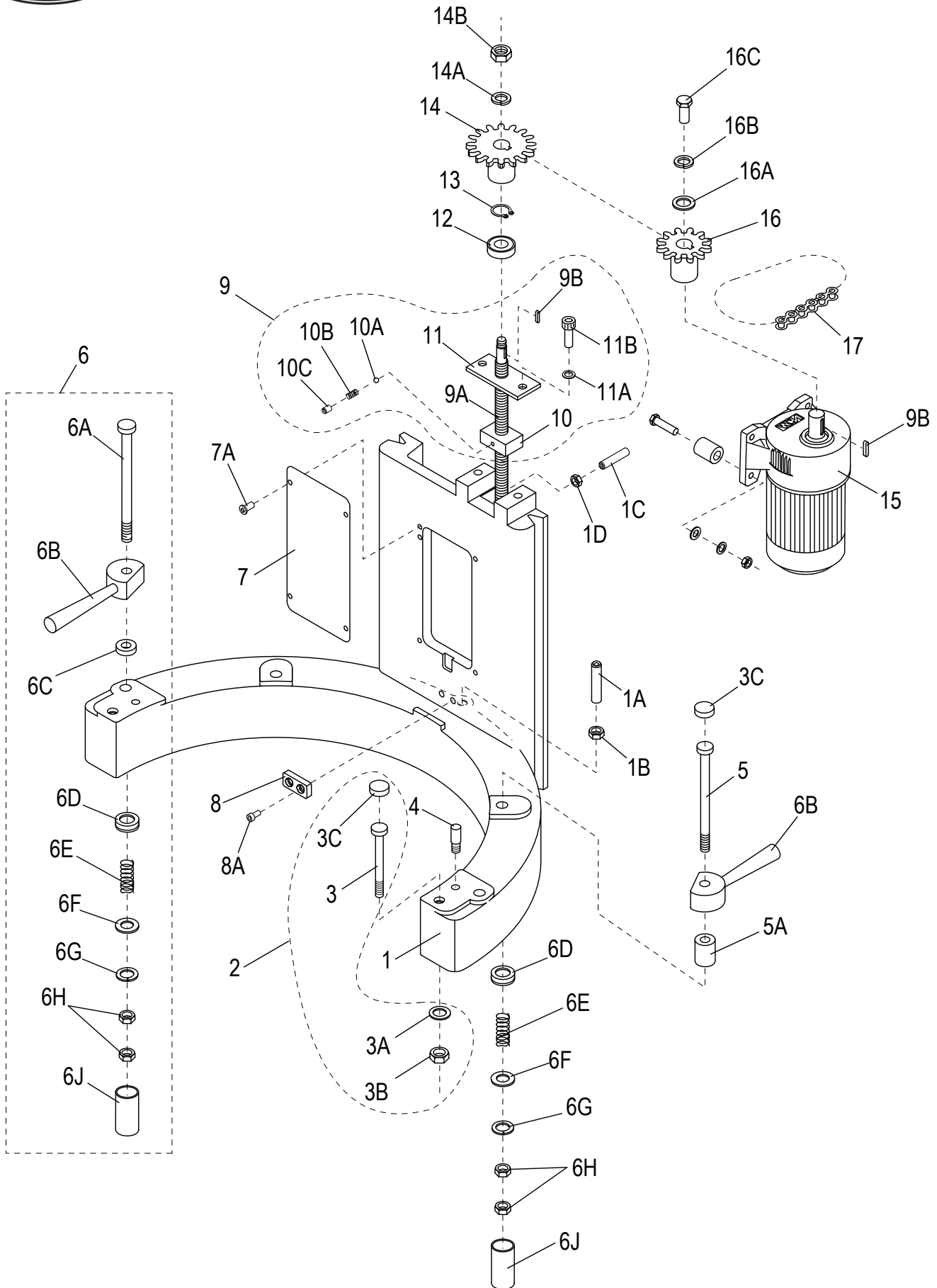



## SP80PL Power Lift Cradle Assembly

Item	Part Number	Description	Qty	Serial Number
1	X80C12	Bowl Cradle	1	
1A		Set Screw M12x80mm Socket Hd - Cup Pt.	1	
1B		Nut M12 Hex	1	
1C		Set Screw M6x40mm Socket Hd - Cup Pt	1	
1D		Nut M6 Hex	1	
2	X80C13	Bowl Locating Assembly	1	
3		Screw M10	1	
3A	X80C11	Washer M12 Split Lock	1	
3B	X80C10	Nut M12 Acorn	1	
3C		Screw Cover	2	
4	X80C14	Dowel Pin, Threaded	2	
5	X80C09	Screw, Bowl Clamp - Rear	2	
5A	X80C07	Bushing, Bronze - Rear Clamp	2	
6	X80C05	Bowl Clamp Assembly (Set/2)	1	
6A	X80C06	Bowl Clamp Screw	2	
6B	X80C05-1	Bowl Clamp (Set/2)	1	
6C	X80C04	Bronze Bushing, Front	2	
6D		Hardware Cap	4	
6E	X80C03	Spring	4	
6F	X80B09	Washer M12 Flat	4	
6G	X80C02	Washer M12 Split Lock	4	
6H	X80C01	Nut M12 Jam	4	
6J		Hardware Cap	4	
7	X80C17	Front Cover, Bowl Cradle	1	
7A	X80C18	Screw M5x10mm Hex Hd	4	
8	X80C16	Locking Bracket	1	
8A	X80C15	Screw M8x35mm Socket Hd & Lock Washer	2	
9	X80C19-24	Bowl Raise Screw Assembly	1	
9A		Bowl Raise Screw	1	
9B	X80H55	Shaft Key 6x6x25mm	2	
10		Nut Block	1	
10A		Roller Ball Ø5 SS	1	
10B		Spring	1	
10C		Set Screw M6x5mm Socket Hd - Cup Pt.	1	
11		Nut Mounting Plate	1	
11A		Washer M10 Split Lock	2	
11B		Screw M10x20mm Socket Hd	1	
12	X08114	Ball Bearing	1	
13	X80C26	Retaining Ring RTW40	1	
14	X80H48	Chain Gear (16T)	1	
14A	X80H49	Washer M16 Split Lock	1	
14B	X80C30	Nut M16 Hex	1	
15	X00705	Motor, 1/8Hp 220V 50/60Hz 1Ph	1	->7810151
15	X80H56	Motor, 1/8Hp 220V 50/60Hz 3Ph	1	->7810151
15	XA-8038-1	Motor, Metal Plate, 220/380V/60Hz/1Ph	1	7810151 ->
15	XA-8038-3	Motor, Metal Plate, 220/380V/60Hz/3Ph	1	7810151 ->
16	X80H53	Chain Gear (11T)	1	
16A	X80H52	Washer M6 Flat	1	
16B	X80H51	Washer M6 Split Lock	1	
16C	X80H50	Screw M6x16mm Hex Hd	1	
17	X80H54	Drive Chain	1	



# SP80PL Gearbox Components

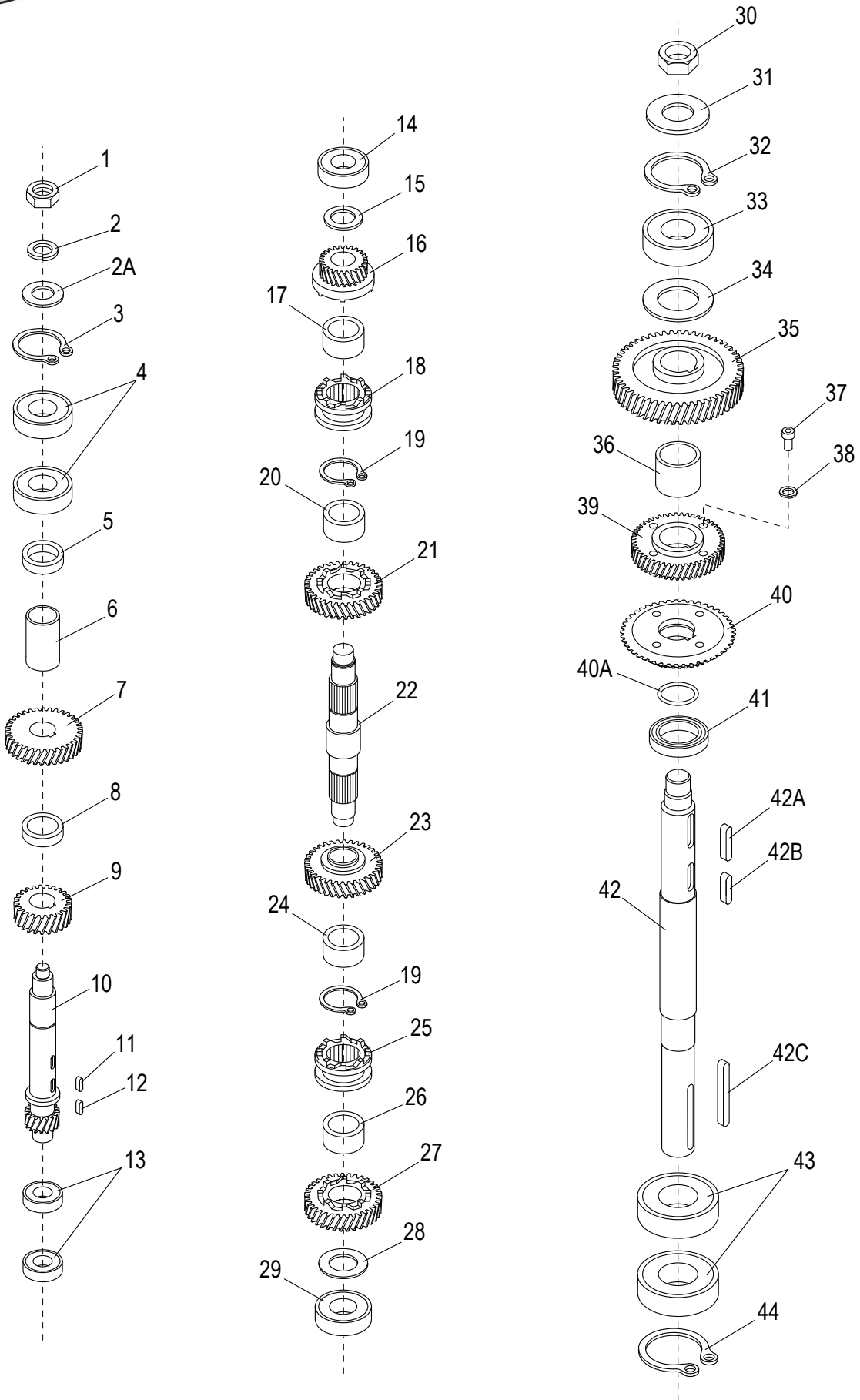





## SP80PL Gearbox Components

Item	Part Number	Description	Qty	Serial Number
1	X80D34	Nut M16 Jam	1	
2	X80D35	Washer M16 Split Lock	1	
2A	H01356	Flat Washer	1	
3	X80D36	Retaining Ring RTW-47	1	
4	X80D37	Ball Bearing	2	
5	X80D38	Spacer	1	
6	X80D38-1	Sleeve	1	
7	X80D39G03-1	Gear & Drive Set 60Hz	220V	1
7	X80D39G03	Gear & Drive Set 50Hz	350V	1
8	X80D40	Bronze Bushing	1	
9	X80D41	Transmission Gear (25T)	1	
10	X80D42	Transmission Shaft (17T)	1	
11	X80D43	Shaft Key 6x6x18mm	1	
12	X80D44	Shaft Key 8x8x20mm	1	
13	X80D37	Ball Bearing	2	
14	X10102	Ball Bearing	1	
15	X80D32	Spacer 29x40x3mm	1	
16	X80D19	Gear & Bushing	1	
17		Bronze Bushing	1	
18	X80D21	Clutch Sleeve	1	
19	X80D22	Retaining Ring STW-35	2	
20		Bronze Bushing	1	
21	X80D24	Gear and Bushing (33T)	1	
22	X80D25	Master Shaft	1	
23	X80D26	Master Shaft Gear (41T)	1	
24		Bronze Bushing	1	
25	X80D21	Clutch Sleeve	1	
26		Bronze Bushing	1	
27	X80D31	Gear and Bushing	1	
28	X80D32	Spacer 29x40x3mm	1	
29	X10102	Ball Bearing	1	
30	X80D16	Jam Nut M32	1	
31	X80D15	Washer M32 Flat	1	
32	X80D14	Retaining Ring RTW-72	1	
33	X30125	Ball Bearing	1	
34	X62D58	Bronze Bushing	1	
35	X80D11	Drive Shaft Gear (53T)	1	
36	X80D10	Bronze Bushing	1	
37	X80D09	Screw M8x28mm Socket Hd	4	
38	X80D08	Washer M8 Split Lock	4	
39	X80D07	Main Shaft Gear (35T)	1	
40	X80D06	Gear (41T)	Fits Inside DIA X80D06	1
40A	X80D05	O-Ring 40mm x 50mm ID	1	
41	X80D02-2	Oil Seal	1	
42	X80D02	Drive Shaft	1	->7810173
42	X80D02-1	Drive Shaft	1	7810173 ->
42A	X80D04	Shaft Key 10x10x35mm	1	
42B	X80D03	Shaft Key 10x10x26mm	1	
42C	X80D01	Shaft Key 10x10x100mm	1	
43	X80D46	Ball Bearing	2	
44	X80D47	Retaining Ring RTW-75	1	



# SP80PL Gear Shift Assembly

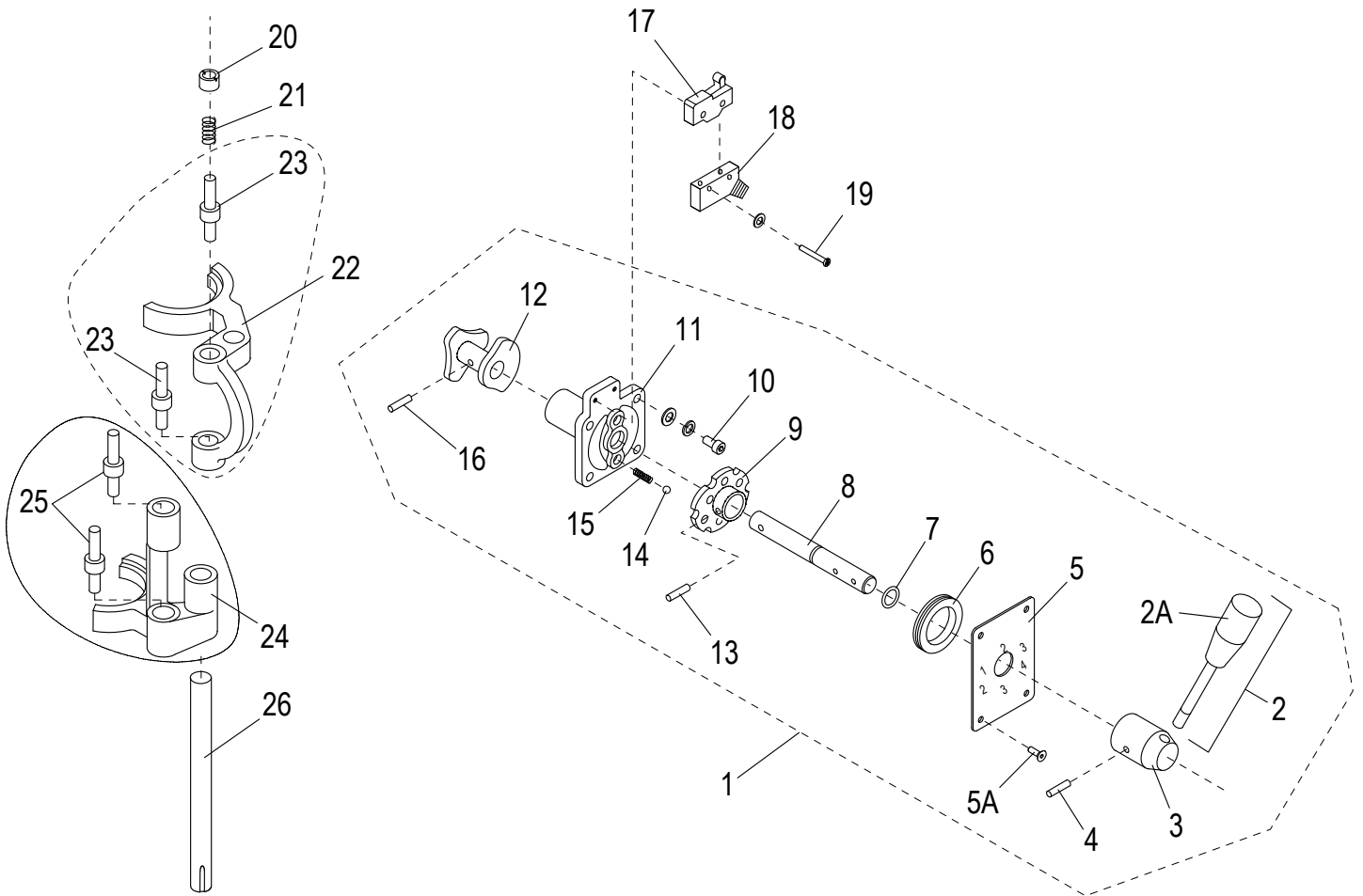



## SP80PL Gear Shift Assembly

Item	Part Number	Description	Qty	Serial Number
1	X80E01-15	Gear Shift Assembly	1	
2	X80E01	Gear Shift Arm Assy (With Knob)	1	
2A	X80E01-1	Knob, Gear Shift	1	
3	X80E02	Gear Shift Arm Hub	1	
4	X80E03	Roll Pin Ø6 x 38mm	1	
5	X80E04	1-4 Speed Indication Plate	1	
5A		Screw M5x14mm Flat Hd	4	
6	X80E05	Oil Seal	1	
7	X80E06	O-Ring P11	1	
8		Shifter Guide Rod	1	
9		Hub & Cam Assy	1	
10		Screw M8x25mm Socket Hd	4	
11		Shaft Cover	1	
12	X80E11	Gear Shift Cam Assy	1	
13	X80E12	Roll Pin Ø5 X 26mm	1	
14		Steel Ball Ø9mm	2	
15		Spring	2	
16	X80E15	Roll Pin Ø6 x 20mm	1	
17	X80E16	Microswitch	1	
18	X80E17	Microswitch Cover	1	
19	X80E18	Screw M4x24mm Pan Hd & Flat Washer	2	
20	X80E19	Nut M20	4	
21	X80E20	Spring	4	
22	X80E22	Speed Shifter Yoke (Top)	1	
23	X80E21	Touch Shaft	2	
24	X80E23	Speed Shifter Yoke (Rear)	1	
25	X80E21	Touch Shaft	2	
26	X80E24	Shifter Guide Rod	1	



# SP80PL Bowl Scraper Components

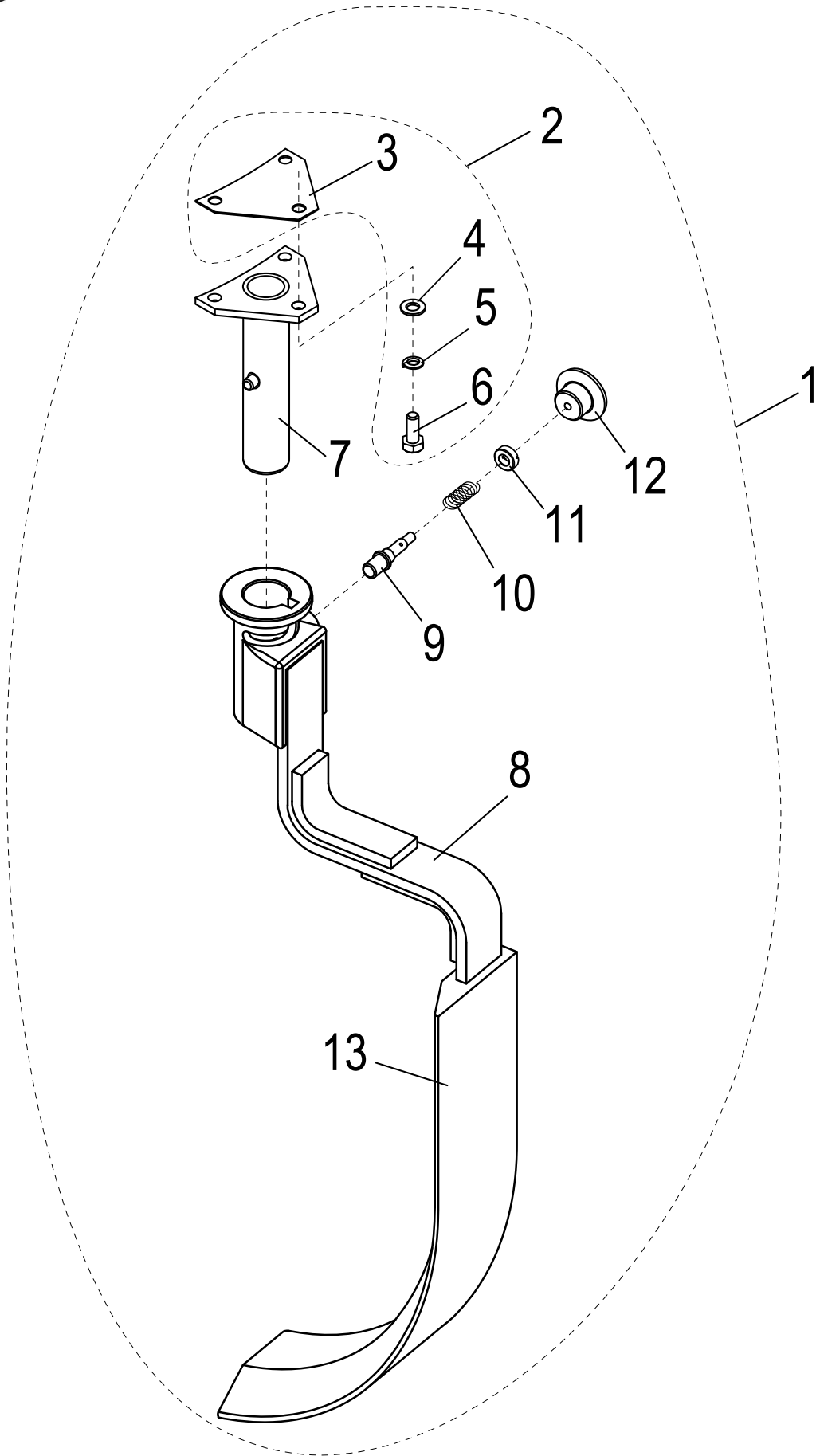



## SP80PL Bowl Scraper Components

---

Item	Part Number	Description	Qty	Serial Number
1	XXSCRP-80	Bowl Scraper Assembly	1	7810035 ->
2	X80519	Hardware Kit	1	
3		Shaft Spacer	1	
4	X80J520	Scraper Hub	1	
5	X01759	Flat Washer M8, ID-8.4, OD-24, TH-2mm	3	
6	H00527	Mixer Mounting M8 Split Lock Washer	3	
7	X30197	Ext. Hex Hd Screw M8-1.25x25mm, SS	3	
8	X80521	Scraper Attachment Arm	1	
9	X80522	Pin	1	
10	X80523	Spring	1	
11	X80524	Spacer	1	
12	X80525	Knob	1	
13	X80526	Bowl Scraper	1	



# SP80PL Planetary Components

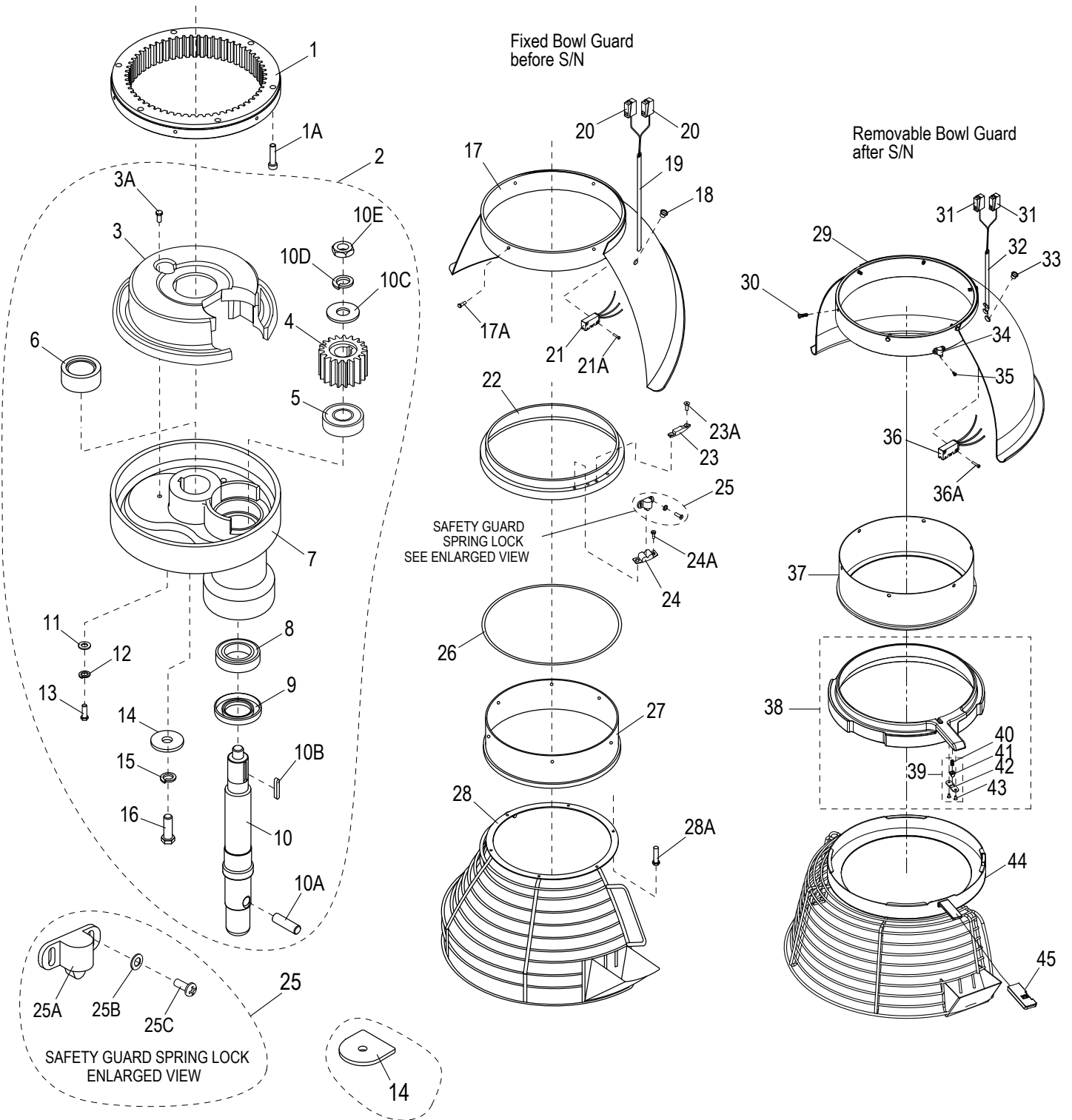



## SP80PL Planetary Components

Item	Part Number	Description	Qty	Serial Number
1	X80F01	Planetary Gear (59T)	1	
1A	X80F03	Screw M8x35mm Socket Hd	6	
2	X01359	Planetary Assembly	1	
3	X80F09-2	Oil Cover	1	
3A		Screw, Hex Hd	1	
4	X80F06	Pinion Gear (18T)	1	
5	X80F07	Ball Bearing	1	
6	X80F18	Guard Oil Bushing	1	
7	X80F09-DG	Planetary Holder	1	
8	X80F10	Ball Bearing	1	
9	X80F11	Oil Seal 40x72x12	1	
10	X62F13	Planetary Shaft	1	->7810173
10	X80F13-1	Planetary Shaft	1	7810172 ->
10A	X80F14	Planetary Shaft Pin M14x38mm	1	
10B	X80F12	Shaft Key 6x6x35mm	1	
10C	X80F05	Washer M16 Flat	1	
10D	X30020	Nut M14 Stop & Washers	1	
10E	X80F02	Nut M16 Jam	1	
11	X80F20	Washer M10 Flat	2	
12	X80F21	Washer M10 Split Lock	2	
13	X80F22	Screw M10x20mm Hex Hd - SS	2	
14	X80F23	Washer M8 Flat - Round	1	->7810173
14	X80F23-1	Washer M10 Flat - D Shape	1	7810172 ->
15	X80F24	Washer M8 Split Lock	1	->7810173
15	X80F24-1	Washer M10 Split Lock	1	7810172 ->
16	X80F25	Screw M8x25mm Hex Hd	1	->7810173
16	X80F25-1	Screw M10x25mm Hex Hd	1	7810172 ->
17	X80J32-33	Rear Guard, Fixed	1	
17A	X80F16	Screw M5x12mm Hex Hd - SS	6	
18	X80J34	Access Plug	2	
19	X80J31A1	Tube Wireway	1	
20	X80J31	Connector	2	
21	X80J35	Microswitch, Safety Interlock	1	->7810122
21	X80J35-1	Microswitch, Safety Interlock	1	7810121 ->
21A	X80J36	Screw M3x16mm Socket Hd	2	
22	X80J43-1	Slide Sheath	1	
23	X10041	Touch Mass	1	
23A	X10042	Flat Hd Screw-Phillips M4-0.7x10mm, Zn	2	
24	X80J42	Safety Guard Spring Lock Fixture	1	
24A	X80J41	Screw M4x12mm Hex Hd - SS	2	
25	X80J39	Safety Guard Spring Lock W/Hardware	1	
25A		Safety Guard Spring Lock	1	
25B		Washer M3 Flat	1	
25C	X10134B	Round Hd Screw-PHH M3-0.5x8mm, SS-18	2	
26	X80J44	Gasket	1	
27	X80J45	Cover, Internal Planetary Gear	1	
28	X80J46/48	Front Interlocking Guard Assy	1	
28A	X80J47	Screw M5x12mm Hex Hd - SS	8	
29	X02616	Rear Guard	1	
30	X80F16	Screw M5x12mm Hex Hd - SS	6	
31	X80J31	Connector	2	
32	X80J31A1	Tube Wireway	1	
33	X80J34	Access Plug	2	



## SP80PL Planetary Components

---

Item	Part Number	Description	Qty	Serial Number
34	X10134	Safety Guard Spring Lock	1	
35	X10134B	Round Hd Screw-PHH M3-0.5x8mm, SS-18	1	
36	X80J35-1	Microswitch, Safety Interlock	1	
36A	X80J36	Screw M3x16mm Socket Hd	2	
37	X02612	Cover, Internal Planetary Gear	1	
38	X02613	Plastic Slide Sheath, Removable	1	
39	X200S3	Spring Plunger Hardware Kit	1	
40		Spring	1	
41		Plunger	1	
42		Plate, Plunger Retention	1	
43		Screw M3x8mm Flat Hd	2	
44	X02615	Bowl Guard Assembly, SS	1	
45	X20504	Handle, Plastic - Removable Safety Guard	1	





*INTENTIONALLY LEFT BLANK PAGE*



# SP80PL Motor Components

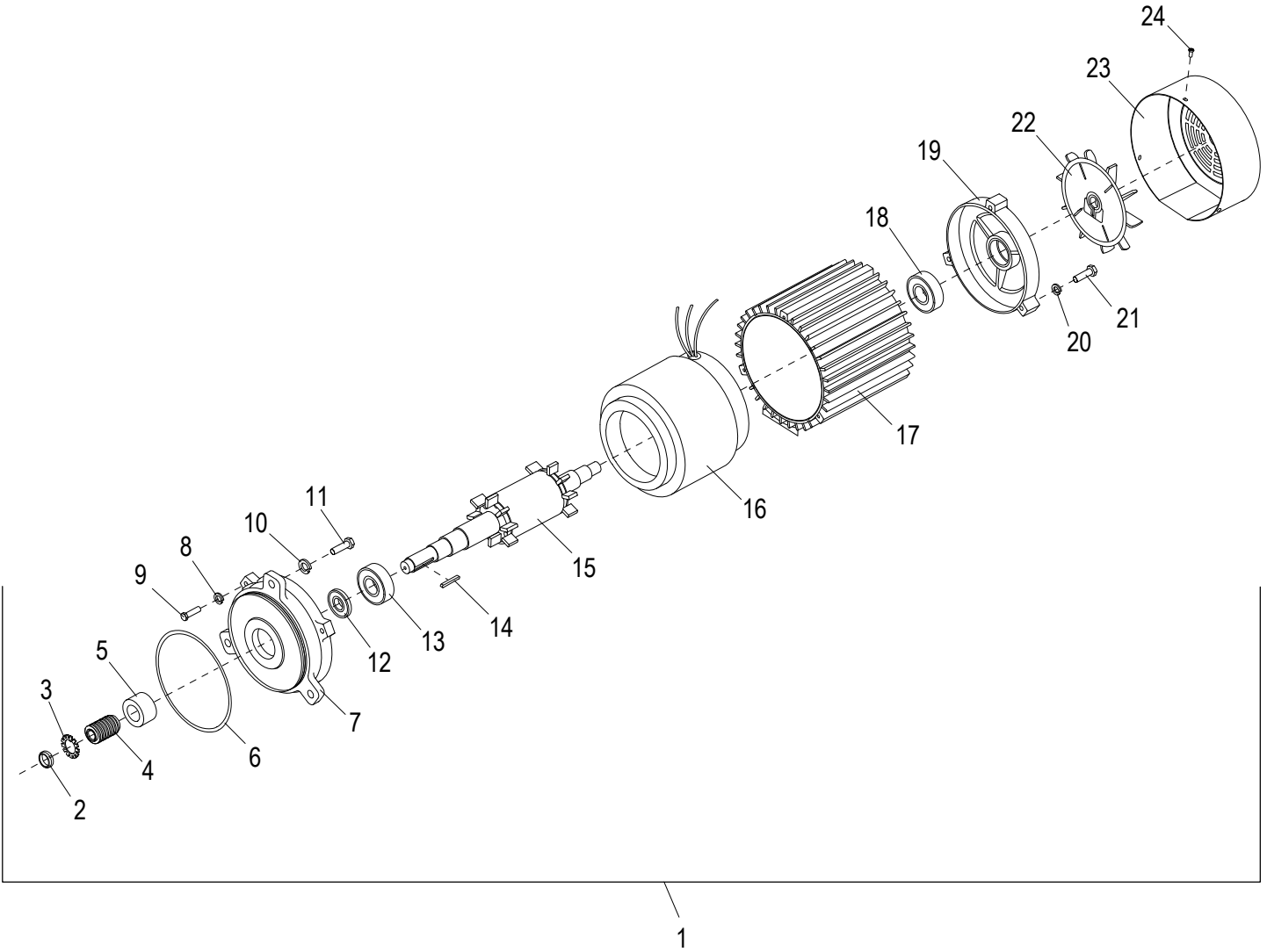



## SP80PL Motor Components

---

Item	Part Number	Description	Qty	Serial Number
1	X80G24	Motor Assembly, 3Hp 220V	1	
1	X80G1-23	Motor Assembly, 3Hp 380V	1	
2	X80G01	Nut M25 Bearing	1	
3	X80G02	Washer M25 External Tooth	1	
4	X80D39G03	Gear & Drive Set 50Hz	1	
4	X80D39G03-1	Gear & Drive Set 60Hz	1	
5	X80G04	Bronze Bushing (Spacer)	1	
6	X80G05	O-Ring P73x3	1	
7		Motor Front Cover	1	
8	X80G07	Washer M6 Split Lock	6	
9	X80G06	Screw M6x20mm Hex Hd	6	
10		Washer M12 Split Lock	3	
11		Screw M12x40mm Hex Hd	3	
12		Washer	1	
13	X40125	Ball Bearing	1	
14		Motor Shaft	1	
15	X25125	Shaft Key 6x6x45mm	1	
16		Motor Coil	1	
17		Motor Body	1	
18	X10012	Ball Bearing	1	
19		Rear Motor Cover	1	
20	X80G07	Washer M6 Split Lock	3	
21	X80G06	Screw M6x20mm Hex Hd	3	
22		Fan	1	
23		Fan Cover	1	
24		Screw M5x12mm Pan Hd	1	



# SP80PL Manual Lift Controls

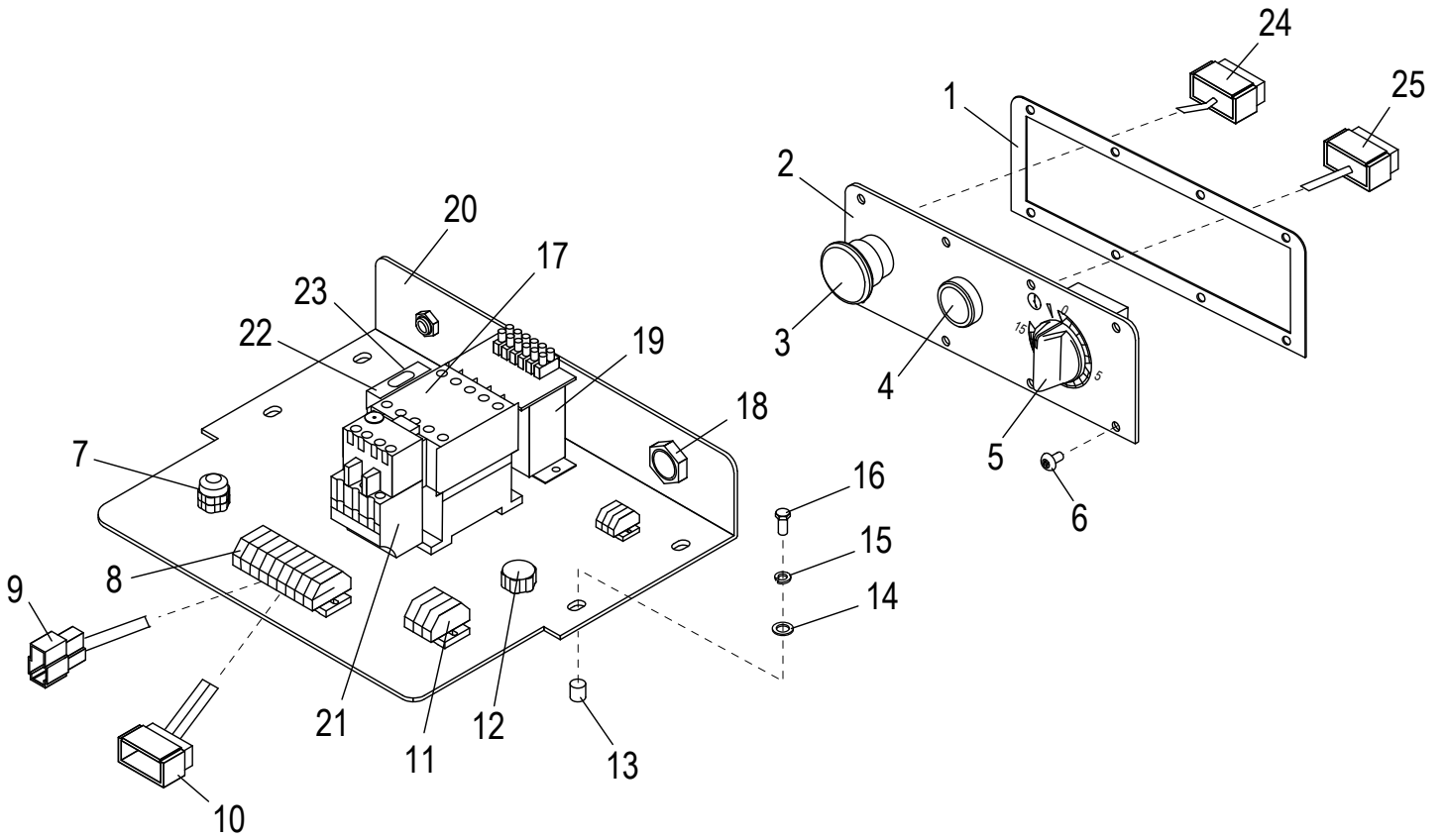



## SP80PL Manual Lift Controls

Item	Part Number	Description	Qty	Serial Number
1	X80J01	Gasket	1	
2	X80J02	Control Panel	1	
3	X80J03	Stop Button	1	
4	X80J04	Start Button	1	
5	X10137	Timer Assembly With Knob	1	
5	X101037-1	Timer Knob	1	
6	X80J06	Screw M4x10mm Truss Hd	8	
7	X80J07	Support Tube	4	
8	X80J08	Connecting Block	1	
9	X80J09	Connector	1	
10	X80J10	Connector	1	
11	X80J11	Terminal Block	3	
12	X80J12	Support Tube	1	
13	X80J13	Socket	4	
14	X80J14	Washer M6 Flat	4	
15	X80J15	Washer M6 Split Lock	4	
16	X80J16	Screw M6x20mm Hex Hd	4	
17	X80J17	Contactactor, 24V	1	
18	X80J18	Support Tube	1	
19	X80J19	Transformer, 24V (220V Mixer)	1	
19		Transformer, 24V (380V Mixer)	1	380V Square D transformer.
20	X80J20	Electronics Mtg Plate	1	
21	X80J21	Overload Relay	1	
22	X80J22	Fuse	2	
23	X80J23	Fuse Fixture	3	
24	X80J24	Connector	1	
25	X80J25	Connector	1	



# SP80PL Power Lift Controls

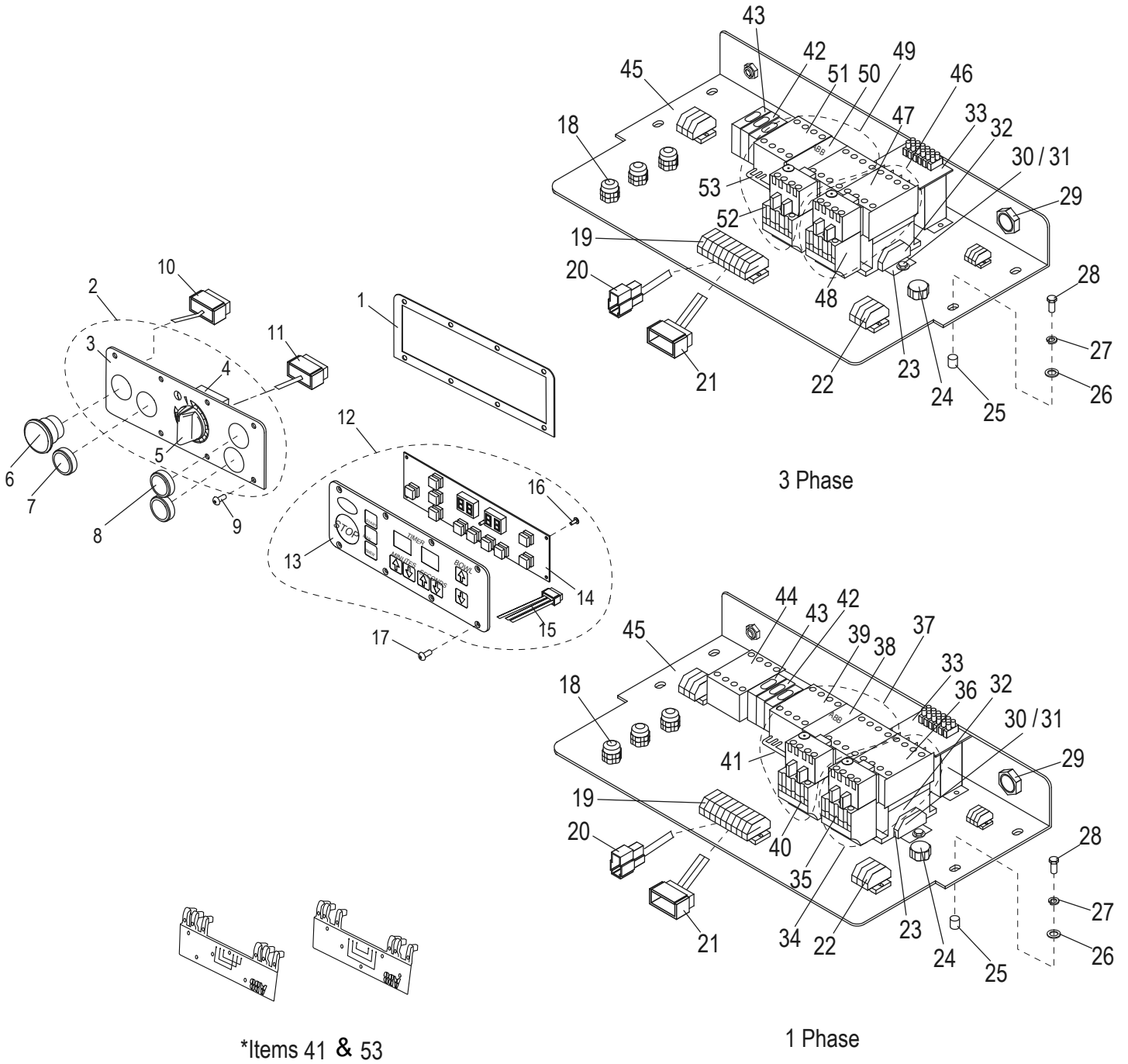



## SP80PL Power Lift Controls

Item	Part Number	Description	Qty	Serial Number
1	X80J01	Gasket	1	
2	X80J49	Faceplate And Timer Assembly	1	
3	X80J02	Control Panel	1	
4	X10137	Timer Assembly With Knob	1	
5	X10137-1	Timer Knob	1	
6	X80J03	Stop Button	1	
7	X80J04	Start Button	1	
8	X80J26	Bowl Raise/Lower Button	2	
9	X30204	Screw M4x10mm Truss Hd	8	
10	X80J24	Connector	1	
11	X80J25	Connector	1	
12	X80J02-1	Control Panel, Digital - Upgrade Kit	1	
13	X02068	Control Panel, Digital	1	
14	X00679	Circuit Board	1	
15		Wiring	1	
16		Screw M3 x 10mm Circuit Board Mounting	5	
17	X30204	Screw M4x10mm Truss Hd	8	
18	X80J07	Support Tube	4	
19	X80J08	Connecting Block	1	
20	X80J09	Connector	1	
21	X80J10	Connector	1	
22	X80J11	Terminal Block	3	
23		Contactors Mounting Plate	1	
24	X80J12	Support Tube	1	
25	X80J13	Socket	4	
26	X80J14	Washer M6 Flat	4	
27	X80J15	Washer M6 Split Lock	4	
28	X80J16	Screw M6x20mm Hex Hd	4	
29	X80J18	Support Tube	1	
30		Screw M3x16mm Round Hd	2	
31		Washer M3 Flat	2	
32		Contactors Locking Caps	2	
33	X80J19	Transformer, 24V (220V Mixer)	1	
33		Transformer, 24V (380V Mixer)	1	*380V Square D transformer.
34	X02061	Main Contactor/Relay Kit	1	
35	X02055	Overload Relay	1	
36	X02058	Contactors	1	
37	X02062	Lift Motor Contactor/Relay Kit	1	
38	X01942	Bridge, Contactor (ABB)	1	
39	X01945	Contactors (ABB)	2	
40	X02056	Overload Relay	1	
41	X01943	Connectors, Contactor (ABB)	1	
42	X80J22A	Fuse, 250V 500Ma	2	
42	X80J22B	Fuse (250 Volt/1A)	1	
43	X80J23	Fuse Fixture	3	
44	X02059	Contactors	1	
45	X80J20	Electronics Mtg Plate	1	
46	X02063	Main Contactor/Relay Kit	1	
47	X02060	Contactors	1	
48	X30154PABB	Overload Relay, 3PH	1	
49	X02064	Lift Motor Contactor/Relay Kit	1	
50	X01943	Connectors, Contactor (ABB)	2	
51	X01942	Bridge, Contactor (ABB)	1	



## SP80PL Power Lift Controls

---

Item	Part Number	Description	Qty	Serial Number
52	X80J30	Bowl Lift Motor Overload Relay	1	
53	X01945	Contactor (ABB)	2	





*INTENTIONALLY LEFT BLANK PAGE*



# SP80PL Wiring Diagram, Manual Lift Mixer

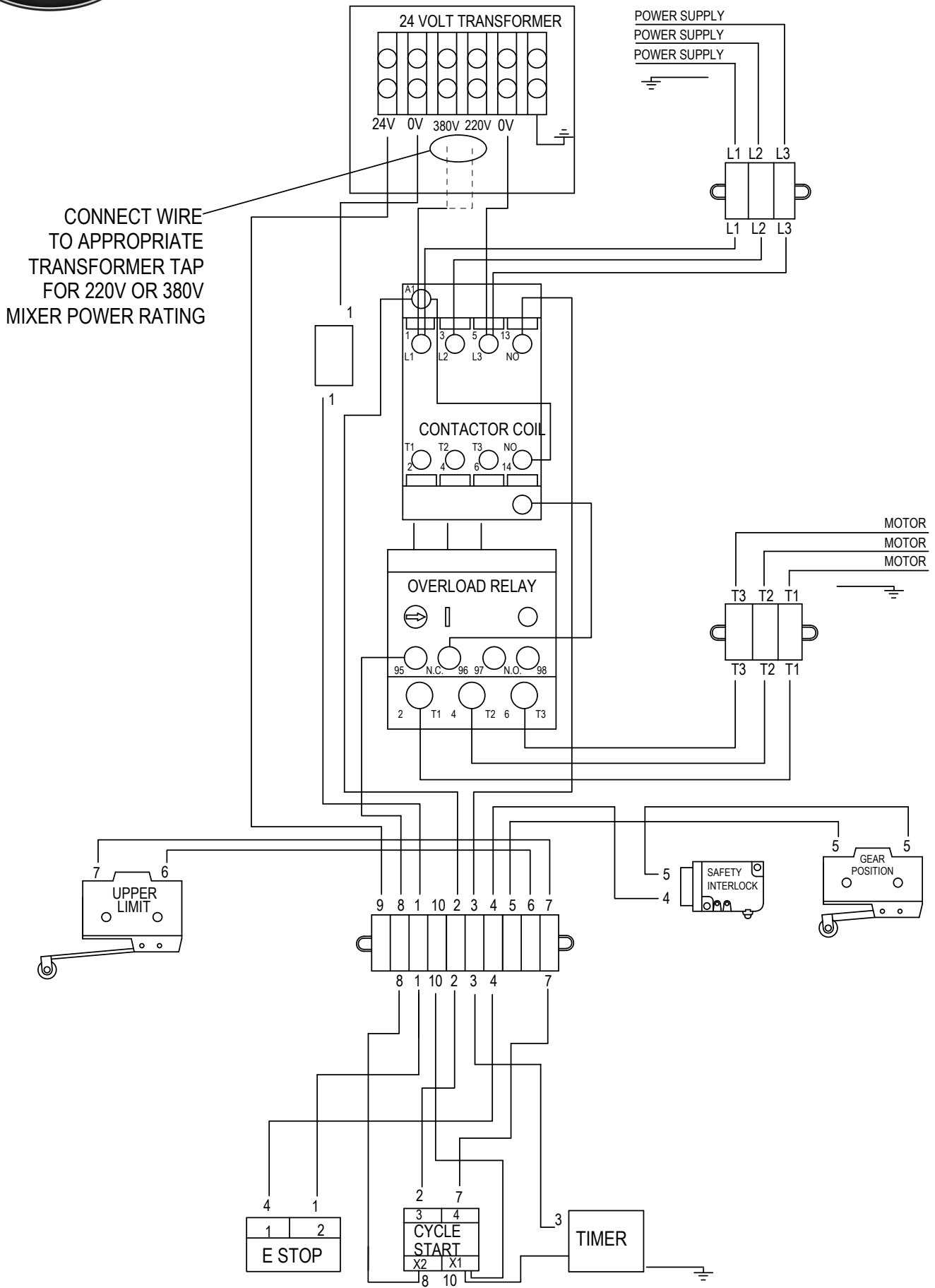



# SP80PL Wiring Diagram, Power Lift Mixer

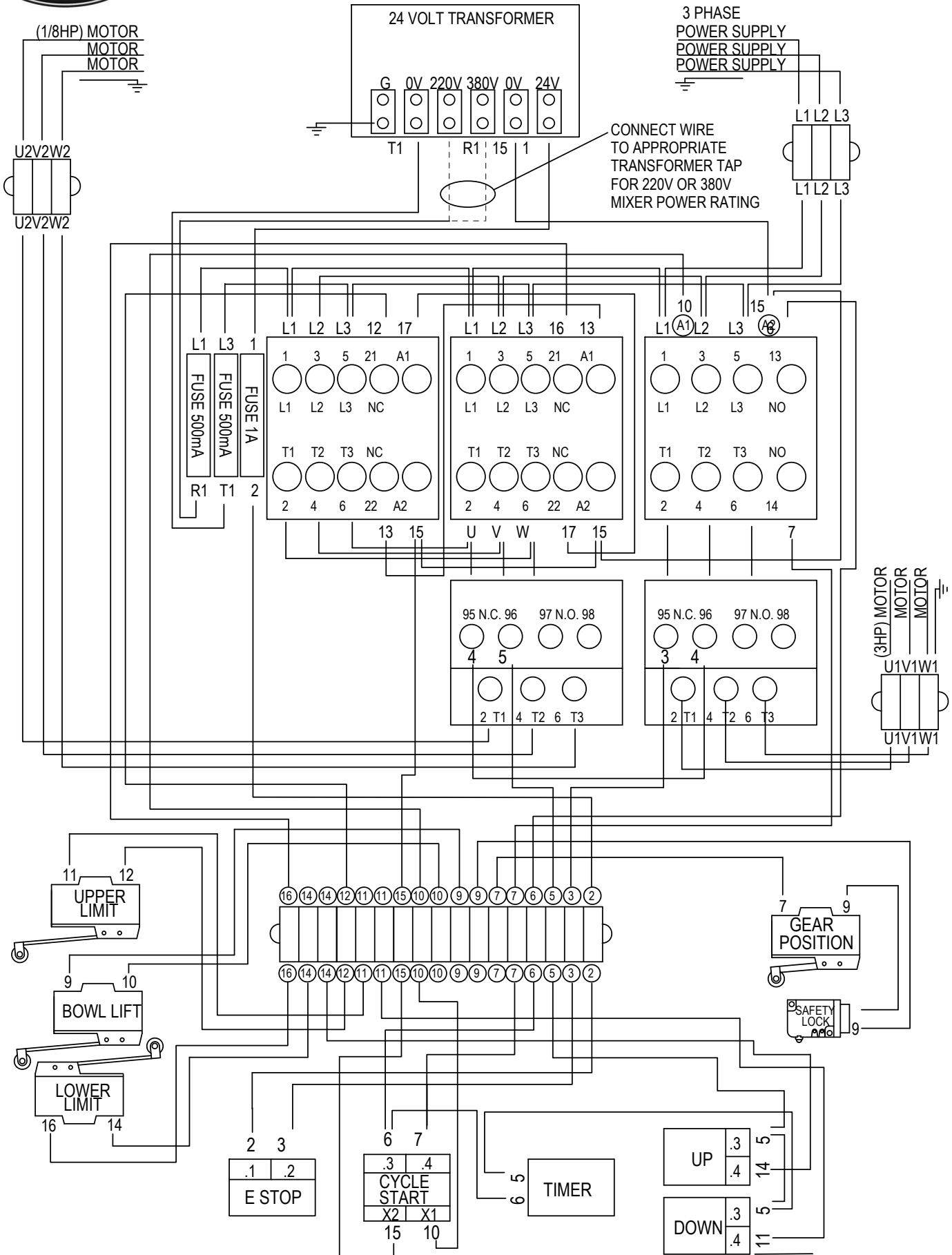



# SP80PL 3 PH 220V Power Lift Mixer Schematic

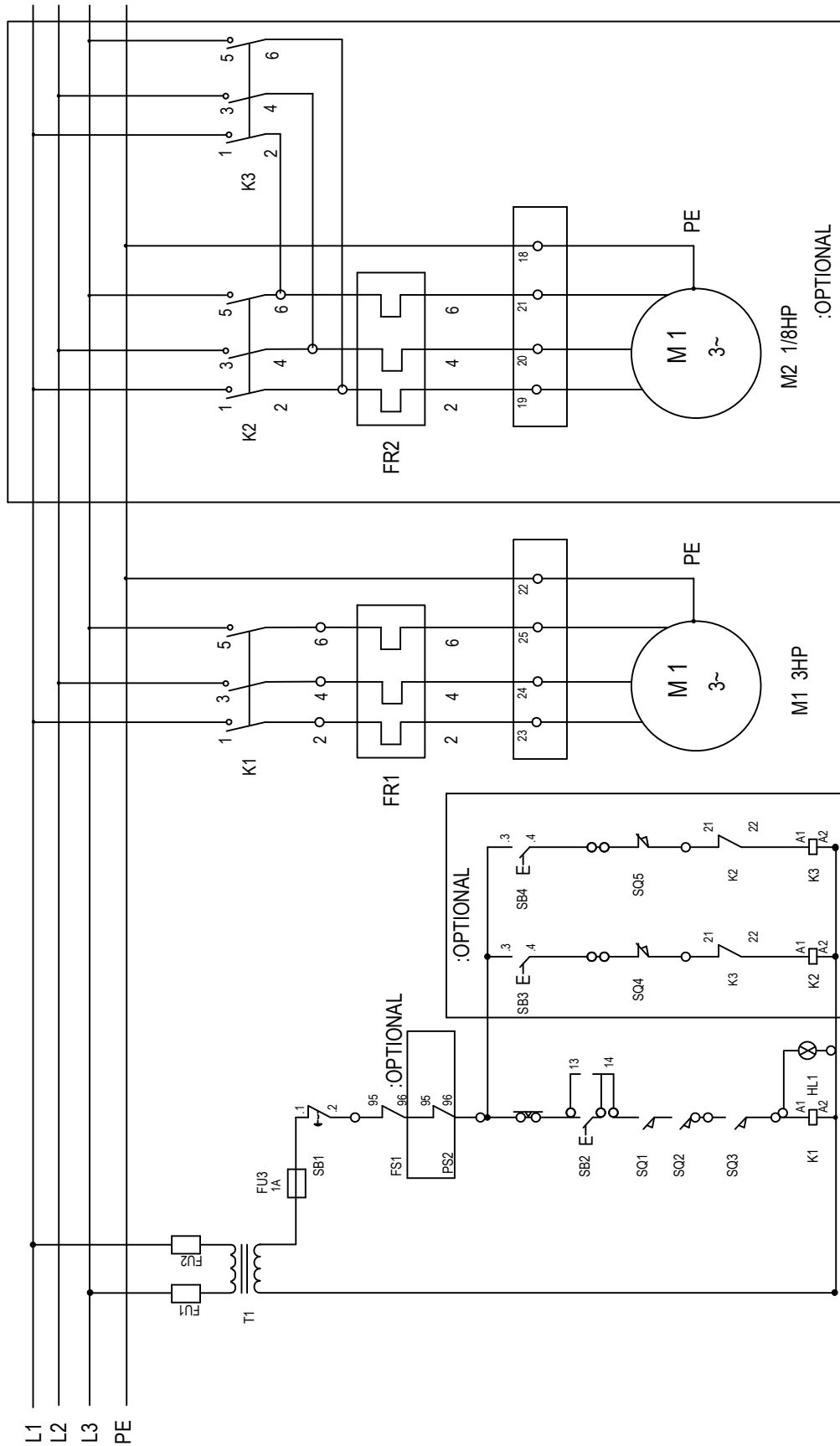

SB3	RAISE BUTTON
SB4	LOWER BUTTON
M2	MOTOR, 1/8HP, 3PH, 220V OR 380V
K2	RAISE CONTACTOR COIL, 24VAC
K3	LOWER CONTACTOR COIL, 24VAC
FS2	OVERLOAD RELAY
T1	TRANSFORMER, 24VAC

M1	MOTOR, 3HP, 3PH, 220V OR 380V
KT1	TIMER
SQ1	MICROSWITCH (TRANSMISSION GEAR)
SQ2	MICROSWITCH (INTERLOCK GUARD)
SQ3	MICROSWITCH (BOWL LIFT SAFETY)
SQ4	MICROSWITCH (BOWL LIFT UPPER LIMIT)
SQ5	MICROSWITCH (BOWL LIFT LOWER LIMIT)

FU4	FUSE FIXTURE + FUSE 1A (5 X 20)
FU5	FUSE FIXTURE + FUSE 1A (5 X 20)
FU6	FUSE FIXTURE + FUSE 1A (5 X 20)
SB1	EMERGENCY STOP BUTTON
SB2	START BUTTON
K1	CONTACT COIL 24VAC
FS1	OVERLOAD RELAY



# SP80PL Wiring Diagram, Power Lift Mixer-Digital Control Panel

TRANSFORMER WIRING MAY VARY IN COMPLIANCE WITH MIXER POWER RATING (220v OR 380v)

