

Parts Catalog



SPC10

Mixer

Model: SPC10

10/02/2019 Rev. B

IMPORTANT!

TO EXPEDITE SHIPMENT OF PARTS, ALWAYS SPECIFY MODEL, REV,
PART NUMBER, AND SERIAL NUMBER OF UNIT.

GLOBE FOOD EQUIPMENT COMPANY

2215 East River Road
Dayton, Ohio 45439

Parts Department

Toll Free 1-800-745-6238 · Fax (937) 290-0585

E-Mail: info@globefoodequip.com

Website: www.globefoodequip.com

Not for resale

Table of Contents

Description	Page
SPC10 Base Components	4
SPC10 Head Components	8
SPC10 Hub Assembly Components	12
SPC10 Planetary Components	14
SPC10 Gearbox Components	16
SPC10 Motor Components	20
SPC10 Motor Brake Components	22
SPC10 Manual Lift Controls	24
SPC10 Wiring Diagram - 120V Single Phase	26
SPC10 Wiring Diagram - 120V Single Phase	27



SPC10 Base Components

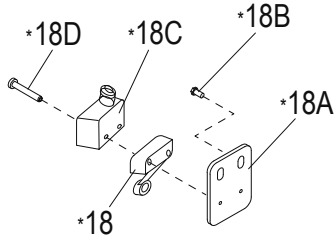

*EXTERNAL ELECTRICAL SYSTEM.
PRIOR TO S/N 7110226

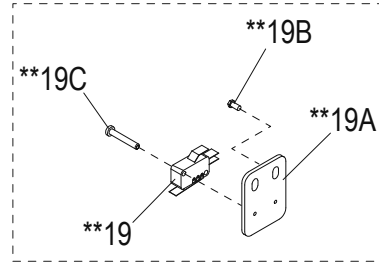

**INTERNAL ELECTRICAL SYSTEM
STARTING WITH S/N 7110226.
MOTOR BRAKE MODELS (SPC)
USE ALTERNATE SWITCH

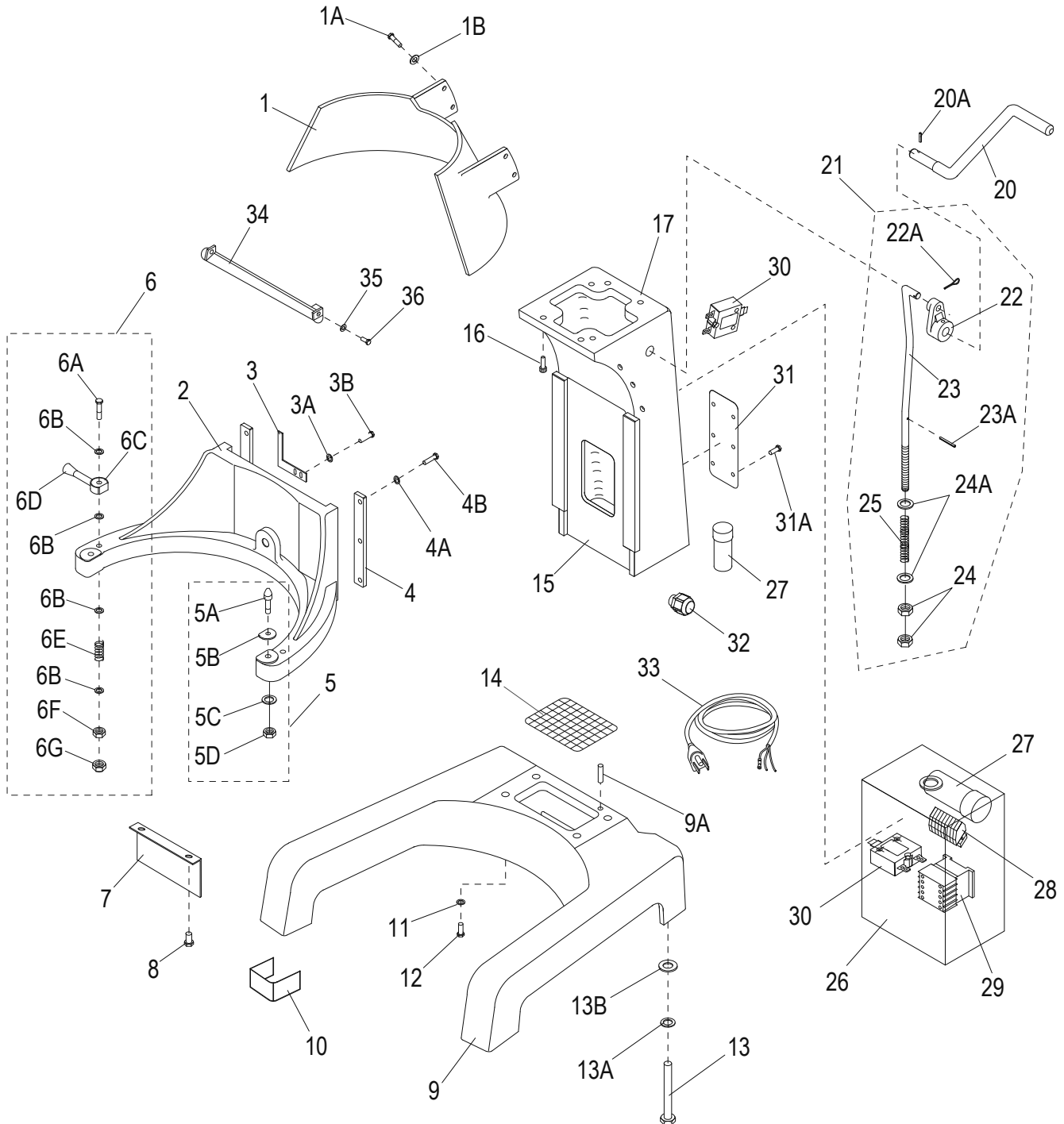



SPC10 Base Components

Item	Part Number	Description	Qty	Serial Number
1	X10023	Rear Guard	1	
1A	X25097	Screw M6x14mm Hex Hd	4	
1B	X25069	Flat Washer, M6 ID-6mm, OD-24mm, TH-3mm, Thick	4	
2	X10021-DG	Bowl Cradle	1	
3	X10190	Touch Mass	1	
3A		Washer M4 Split Lock	2	
3B	X80J41	Screw M4x12mm Hex Hd - SS	2	
4	X10022	Bowl Slide	2	
4A	X80H51	Washer M6 Split Lock	6	
4B	X25097	Screw M6x14mm Hex Hd	6	
5	X20087	Dowel Screw Assembly (Incl. items 5A-5D)	2	
5A		Dowel Screw	2	
5B	X01759	Flat Washer M8, ID-8.4, OD-24, TH-2mm	2	
5C	X08102	Lock Washer M8 ID-8.5, OD-14.8, TH-2mm Zn	2	
5D	X10088	Cap Nut M8-1.25, OD-13, TH-15mm Zinc	2	
6	X10020	Bowl Clamp Assembly (Set/2) (Incl. items 6A-6G)	1	
6A		Bowl Clamp Screw	2	
6B		Washer M8 Flat	8	
6C	X10020-1	Bowl Clamp (Set/2)	1	
6D		Bowl Clamp Handle	2	
6E		Spring	2	
6F		Nut M8 Hex	2	
6G		Nut M8 Acorn	2	
7		Cover, Cradle	1	
8	X40056	Truss Hd Screw PHH M6-1.0x10mm, SS-18	2	
9	X10024-DG	Mixer Base	1	
9A		Dowel Pin Ø8x15mm	2	
10	X10136	Front/Rear Rubber Feet (Set/4)	4	
11		Washer M10 Flat	4	
12		Screw M10x40mm Hex Hd	4	
13	X10025	Ext. Hex Hd Screw M10-1.5x60mm, Zinc	4	
13A	X80B02	Washer M10 Split Lock	4	
13B	X10034	Washer M10 Flat	4	
14	X10031	Screen	1	
15	X10035-1-DG	Mixer Column, New Style	1	
16		Cap Screw M8x25mm Socket Hd	4	
17	X91014	Label, Hazardous Voltage	Not Shown	
18	X30219	Microswitch, Bowl Lift	Ext. Elect. Sys.	1
18A		Bracket	Ext. Elect. Sys.	1
18B	X40056	Truss Hd Screw PHH M6-1.0x10mm, SS-18	Ext. Elect. Sys.	2
18C	X10084	Cover, Microswitch	Ext. Elect. Sys.	1
18D		Screw M5x10mm Round Hd - Switch Mounting	Ext. Elect. Sys.	2
19	X10057	Microswitch, Interlock		1
19A		Bracket		1
19B	X40056	Truss Hd Screw PHH M6-1.0x10mm, SS-18		2
19C		Screw M5x10mm Round Hd - Switch Mounting		2
20	X10040	Bowl Lift Arm		1
20A	X10039	Dowel Pin Ø5x30mm		1
21	X10037A	Bowl Lift Arm Assembly (Incl. items 22-25)		1
22		Bowl Lift Cam		1
22A		Cotter Pin		1
23		Bowl Lift Rod		1
23A		Roll Pin Ø3x28mm		1



SPC10 Base Components

Item	Part Number	Description	Qty	Serial Number
24		Nut M10 Hex	2	
24A	X10034	Washer M10 Flat	2	
25		Spring	1	
26	X10030	Electrical Box	1	Ext. Elect. Sys.
27	X10026	Capacitor, Start - 200MF	1	
28	X10029A	Connecting Block Set	1	
28	X10029-2G	Connecting Block, Gray (2C)	7	
28	X10029-EC	Connecting Block End Cap	1	
29	X10028ABB	Contactora, 12V, 300VAC	1	Ext. Elect. Sys.
30	X10027-1	Circuit Breaker (Old Style, E-T-A Series)	1	
30	X10027-2	Circuit Breaker (New Style, 74 Series)	1	
31	X10191	Cover Plate	1	Int. Elect. Sys.
31A	X25051	Rd Hd Screw-PHH #10-24x1/4, SS-18	4	Int. Elect. Sys.
32		Strain Relief	1	Int. Elect. Sys.
33		Power Cord And Plug	1	Int. Elect. Sys.
34	X20184	Front Guard, Mixer Column	1	Int. Elect. Sys.
35		Washer M6 Flat	2	Int. Elect. Sys.
36	X40056	Truss Hd Screw PHH M6-1.0x10mm, SS-18	2	Int. Elect. Sys.



INTENTIONALLY LEFT BLANK PAGE



SPC10 Head Components

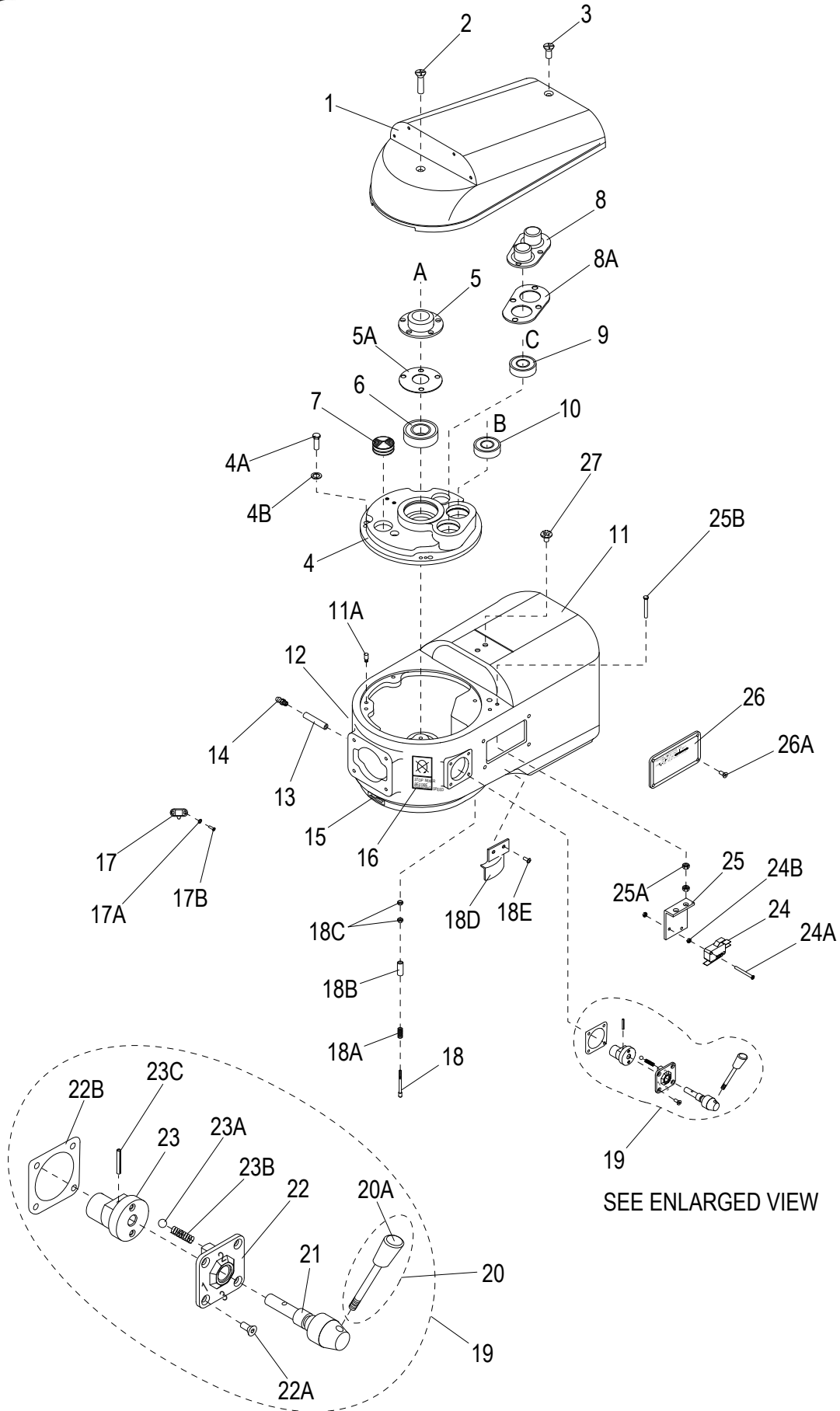



SPC10 Head Components

Item	Part Number	Description	Qty	Serial Number
1	X10001-1	Transmission Cover-Side Controls	1	
1	X10001-2-DG	Transmission Cover-Front Controls	1	
2	X10180	Flat Hd Screw-PHH 1/4"-20x1.25", Zinc	1	
3	X10181	Flat Hd Screw-PHH 1/4"-20x0.75", Zinc	1	
4	X10074	Transmission Case Lid	1	
4A		Screw M6x16mm Hex Hd	4	
4B		Washer M6 Split Lock	4	
5	X10072	Bearing Retainer Cap	1	
5A	X10187	Gasket, Bearing Retainer	1	
6	X10010	Ball Bearing	1	
7	X10073	Oil Plug	1	
8	X10071	Twin Bearing Retainer	1	
8A	X10188	Gasket, Twin Bearing Retainer	1	
9	X10068	Ball #35 Bearing	1	
10	X10068	Ball #35 Bearing	1	
11	X10059	Case, Transmission - Fixed Bowl Guard	1	
11	X10059-1	Case, Transmission - Removable Bowl Guard	1	
11A		Locating Pin Ø8xM6x10mm	2	
12	X91009	Label, Lubricate	1	
13	X10217	Grease Tube	1	
14	X10900	Grease Fitting	1	
15	X91012	Label, Arrow	1	
16	X91010	Label, Stop To Chg Gears	1	
17	X10134	Safety Guard Spring Lock	1	
17A	X10134A	Washer M3 Split Lock	2	
17B	X10134B	Round Hd Screw-PHH M3-0.5x8mm, SS-18	2	
18	X10043	Touch Shaft, Brass	1	
18	X10043N	Touch Shaft, Nylon	1	
18A	X30095	Spring	1	
18B		Tube	1	
18C	X30186	Hex Nut M5-0.8 OD-8, TH-4mm, Zinc	2	
18D	X20516	Cover, Touch Shaft (Removable Bowl Guard)	1	
18E		Screw M5x8mm Truss Hd	2	
19	X10045-48	Gear Shift Lever Assembly (Incl. items 20-23C)	1	
20	X10045	Gear Shift Lever Assy With Knob (Incl. item 20A)	1	
20A	X10045-1	Knob, Gear Shift	1	
21		Shaft	1	
22		Cover	1	
22A	X25166	Flat Hd Screw-PHH M5-0.8x16mm, Zinc	4	
22B	X10199	Gasket	1	
23		Shaft Bias	1	
23A		Roller	2	
23B		Spring	2	
23C		Roll Ø3x28mm Pin	1	
24	X10057	Microswitch, Interlock	1	
24	X10057-1	Microswitch, Interlock	1	
24A		Screw M3x12mm Switch Mounting	2	
24B		Washer M18 Flat	4	
25	X10058	Bracket, Microswitch	1	
25A		Nut M6 Hex	4	
25B		Screw M6x40mm Hex Hd - Bracket Mounting	2	
26	X10055	Plate, Warning	1	
26A		Screw M4x6mm Pan Hd	4	



SPC10 Head Components

Item	Part Number	Description	Qty	Serial Number
27	X10131	Rd Hd Screw-PHH #10-24x3/8", Zinc	Int. Elec. Sys. Only 1	



INTENTIONALLY LEFT BLANK PAGE



SPC10 Hub Assembly Components

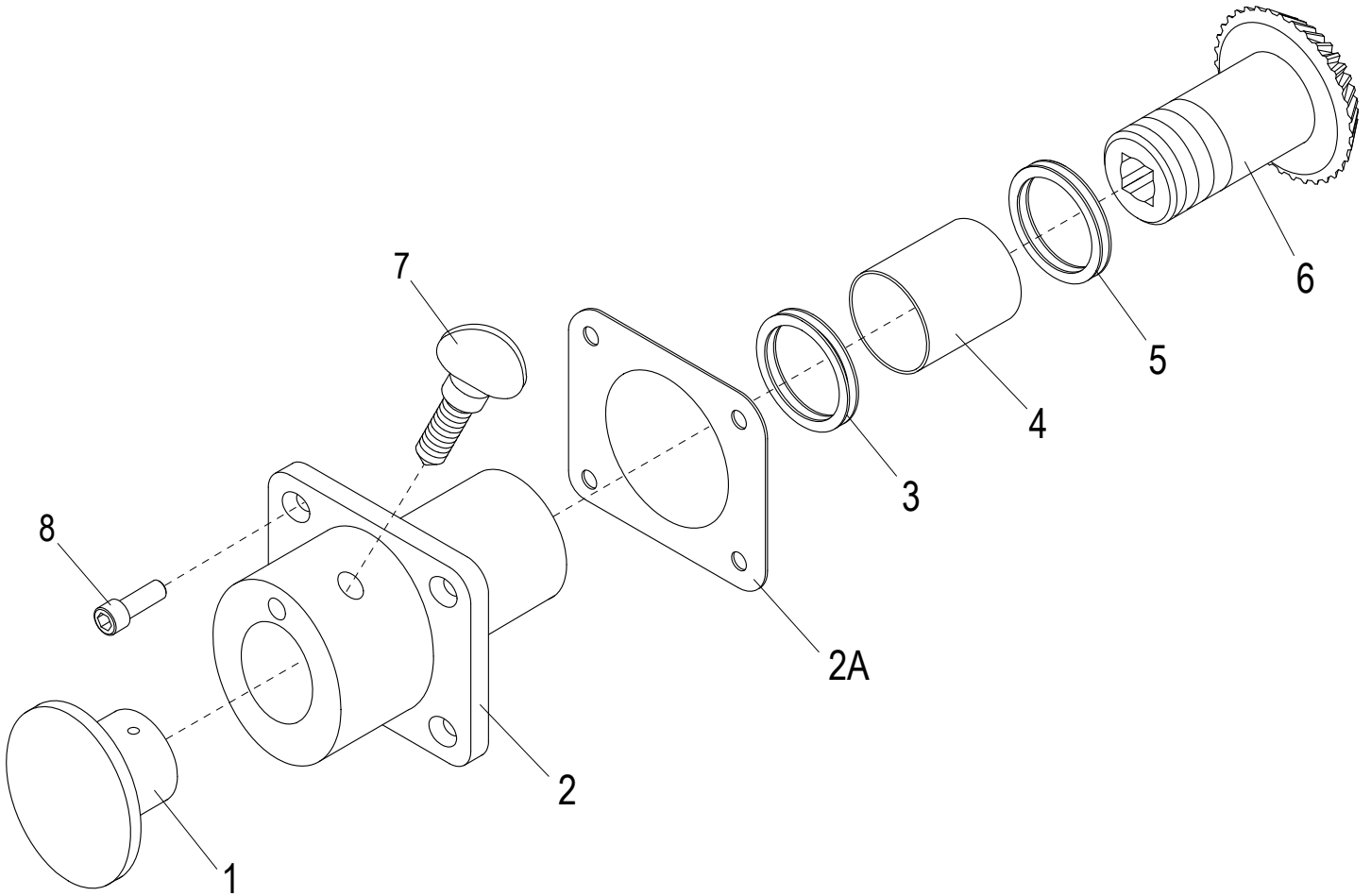



SPC10 Hub Assembly Components

Item	Part Number	Description	Qty	Serial Number
1	X10007	Attachment Hole Plug	1	
2	X10006-DG	Attachment Hub	Includes *	1
2A		Gasket		1
3	X10089	Oil 45x35x8mm Seal	*	1
4	X10075	Bearing	*	1
5	X10004	Thrust Washer ID-36, OD-47, TH-0.5mm		2
6	X10003	Level Drive Gear (35T)		1
7	X10005	Thumb Screw 1/2-13x3/4"		1
8	X80B52	Socket Hd Cap Screw M6-1.0x20mm, B.O.		4

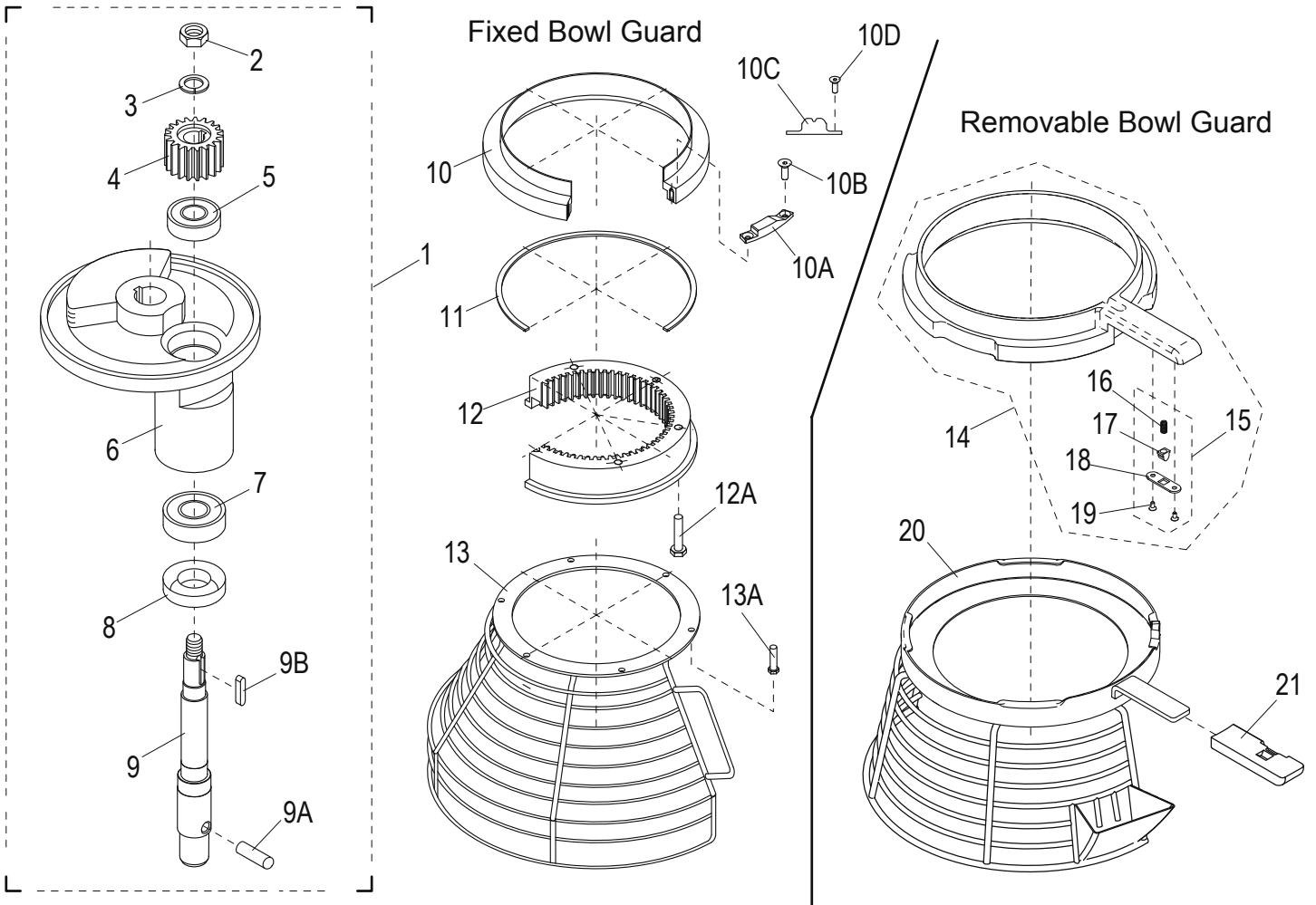



SPC10 Planetary Components

Item	Part Number	Description	Qty	Serial Number
1	X10008-82	Complete Planetary Assembly (Incl. items 2-9B)	1	
2	X10008	Hex Nut M12-1.25, OD-19, HT-10mm, Zinc	1	
3	X80B05	Lock Washer M12, ID-12.7, OD-21.1, TH-2.5mm, SS	1	
4	X10009	Pinion, Beater (19T)	1	
5	X10010	Ball Bearing	1	
6	X10011-DG	Planetary Holder	1	
7	X10012	Ball Bearing	1	
8	X10013	Oil Seal	1	
9	X10015	Planetary Shaft	1	
9A	X10080	Dowel Pin	1	
9B	X10014	Key H-5xW-5xL-17mm, Round Ends (Incl. with X10015)	1	
10	X10076P	Slide Sheath, Molded	1	
10A	X10041	Touch Mass	1	
10B	X10042	Flat Hd Screw-Phillips M4-0.7x10mm, Zn	2	
10C	X10135	Safety Guard Spring Lock Fixture	1	
10D		Screw M4x10mm Round Hd	2	
11	X10077	Teflon Mat	1	
12	X10078	Planetary Internal Gear (63T)	1	
12A	X10082	Screw 1/4-20 x 1.25" Socket Hd	6	
13	X10079/81	Front Interlock Guard Assembly	1	
13A	X10083	Ext. Hex Hd Screw M5-0.8x10mm, SS	6	
14	X200S2	Plastic Slide Sheath, Removable Safety Guard (Incl. items 15-19)	1	
15	X200S3	Spring Plunger Hardware Kit	1	
16		Spring	1	
17		Plunger	1	
18		Plate, Plunger Retention	1	
19		Screw M3x8mm Flat Hd	2	
20	X100S1	Bowl Guard Assembly, Stainless Steel	1	
21	X20504	Handle, Plastic - Removable Safety Guard	1	



SPC10 Gearbox Components

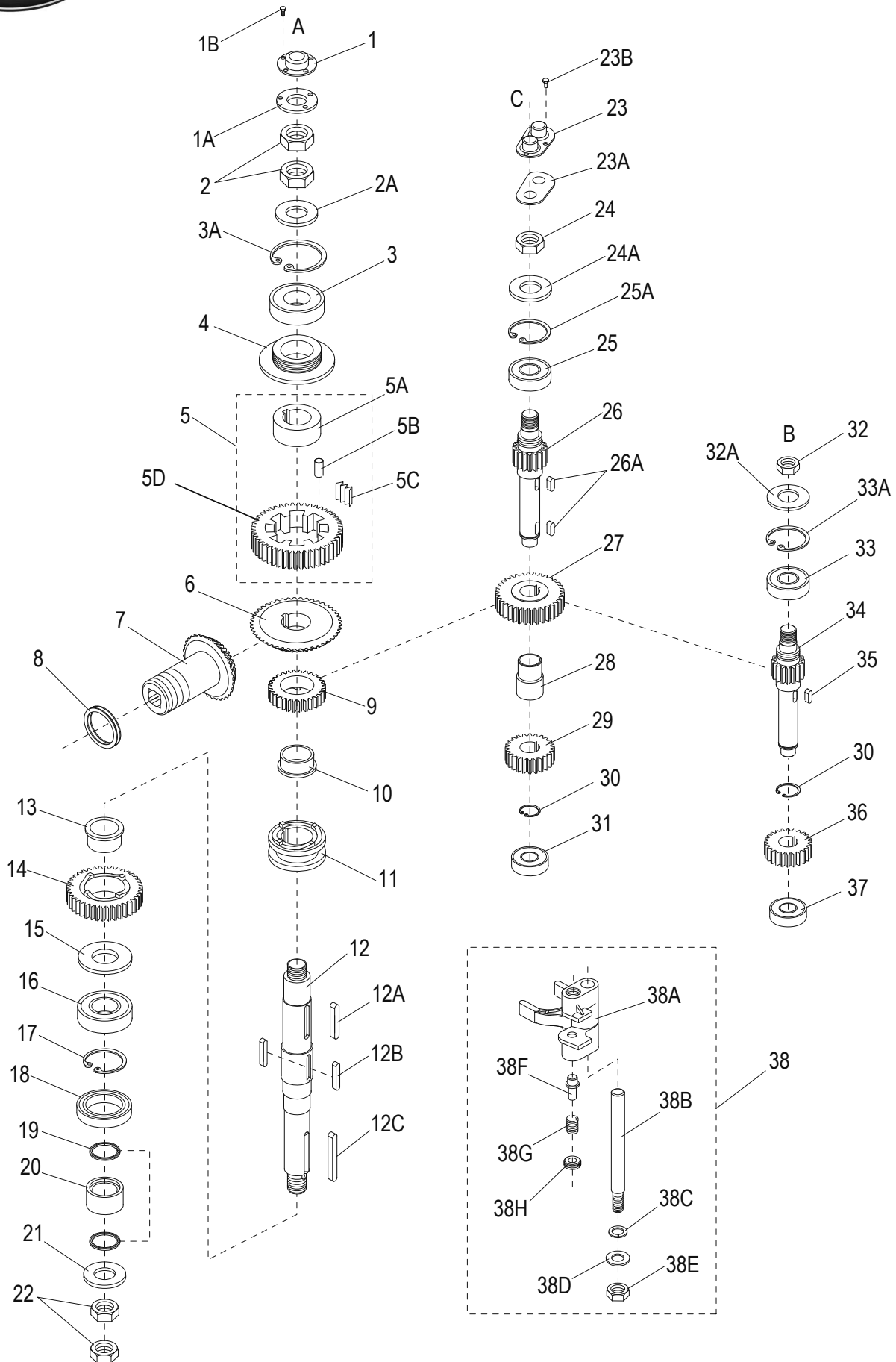



SPC10 Gearbox Components

Item	Part Number	Description	Qty	Serial Number
1	X10072	Bearing Retainer Cap	1	
1A	X10187	Gasket, Bearing Retainer	1	
1B	X10133	Pan Hd Screw-PHH M6-1.0x10mm, SS	4	
2	X10132	Thin Hex Nut 1/2-20, OD-1/2", TH-11/64" Zn	2	
2A		Washer 1/2" Flat	1	
3	X10010	Ball Bearing	1	
3A		Retaining Ring	1	
4	X10090	Lead-In Oil Pad	1	
5	X10091-94	Slow Speed Gear Assembly	Incl. items 5A-5D)	1
5A	X10091	Bushing	1	
5B		Dowel Ø8x16mm Pin	1	
5C	X10093	Slice Spring	8	
5D		Gear, Slow Speed (46T)	8	
6	X10095	Gear, Bevel (46T)	1	
7	X10003	Level Drive Gear (35T)	1	
8	X10004	Thrust Washer ID-36, OD-47, TH-0.5mm	1	
9	X10096	Gear, Clutch (29T)	1	
10	X10097	Bushing, Clutch	1	
11	X10110	Sleeve, Clutch	1	
12	X10107	Drive Shaft	1	
12A	X10098	Key H-6xW-6xL-28mm, Round Ends	1	
12B	X10109	Shaft Key 5x5x27mm	1	
12C	X10108	Shaft Key 6x6x45mm	1	
13	X10097	Bushing, Clutch	1	
14	X10100	Gear, Clutch (38T)	1	
15	X10101	Washer, Stepped	1	
16	X10102	Ball Bearing	1	
17		Retaining Ring RTW-52	1	
18	X10105	Oil Seal	1	
19	X10103	O-Ring 28x22x3mm	2	
20	X10104	Guard, Oil Bushing	1	
21		Washer M20 Flat	1	
22	X10106	Thin Hex Nut 3/4"-16, OD-1-1/8", HT-27/64", Zn	2	
23	X10071	Twin Bearing Retainer	1	
23A	X10188	Gasket, Twin Bearing Retainer	1	
23B	X10131	Rd Hd Screw-PHH #10-24x3/8", Zinc	4	
24	X10130	Thin Hex Nut 3/4"-16, OD-1-18", HT-27/64", Zn	1	
24A		Washer 3/8" Flat	1	
25	X10068	Ball #35 Bearing	1	
25A		Retaining Ring	1	
26	X10129	Transmission Shaft (15T)	1	
26A	X10128	Key H-5xW-5xL-14mm, Round Ends	2	
27	X10126	Gear (32T)	1	
28	X10122	Bushing, Spacer	1	
29	X10121	Gear (24T)	1	
30	X10120	Retaining Ring STW-19	2	
31	X10117	Drive Shaft Upper Ball Bearing	1	
32	X10125	Thin Hex Nut 3/8-24, OD-9/16", TH-7/32", Zn	1	
32A	X10034	Washer M10 Flat	1	
33	X10068	Ball #35 Bearing	1	
33A		Retaining Ring	1	
34	X10124	Shaft, Master (15T)	1	
35	X10123	Key H-5xW-5xL-18mm, Round Ends	1	



SPC10 Gearbox Components

Item	Part Number	Description	Qty	Serial Number
36	X10118-24T	Worm Wheel (24T)	1	
36	X10118	Worm Wheel (29T)	1	
37	X10117	Drive Shaft Upper Ball Bearing	1	
38	X10111-116	Yoke Shifter Assembly (Incl. items 38A-38H)	1	
38A		Yoke Shifter	1	
38B		Guide, Rod Shifter	1	
38C		Washer 3/8" Split Lock	1	
38D		Washer 3/8" Flat	1	
38E		Nut 3/8-16 Stop	1	
38F		Plunger, Yoke Shifter	2	
38G		Spring, Retainer	2	
38H		Spring, Yoke Shifter	2	



INTENTIONALLY LEFT BLANK PAGE



SPC10 Motor Components

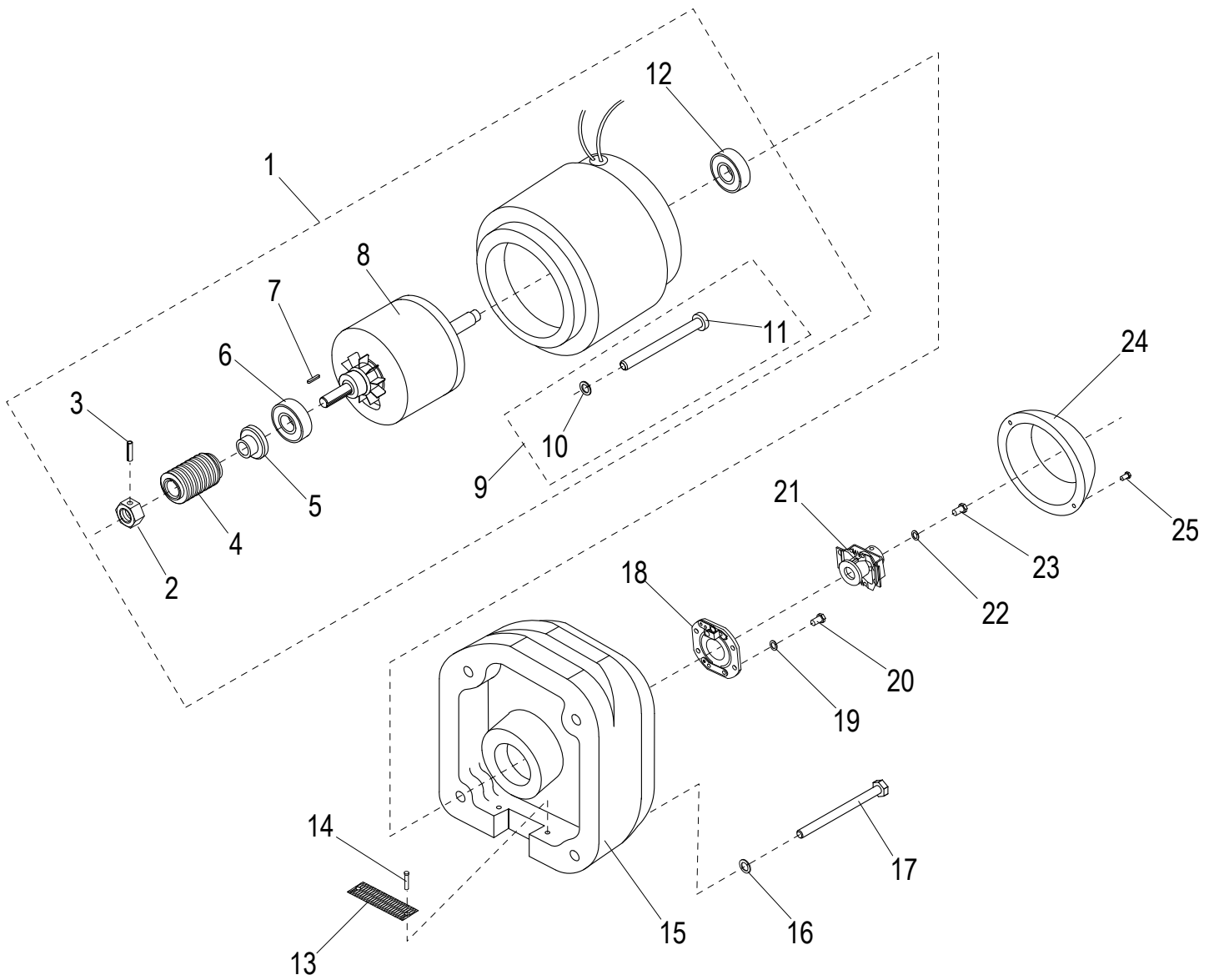



SPC10 Motor Components

Item	Part Number	Description	Qty	Serial Number
1	X10060-67C	Motor Assembly, 1/3 HP - Motor Brake (Incl. items 2-12)	1	
2	X20066	Hex Nut 7/16, OD-11/16", TH-3/8", Zn	1	
3		Roll Pin M3x16mm	1	
4	X20065	Worm (5T)	1	
5	X20060	Spring Shock Absorber	1	
6	X08114	Ball Bearing	1	
7	X20202	Key H-3xW-3xL-18mm, Round Ends	1	
8		Motor Shaft	1	
8		Motor Coil	1	
9	X20206-207	Screw And Lock Washer Set (Incl. items 10-11)	1	
10	X20207	Lock Washer M5, ID-5.4, OD-8.8, TH-2mm, SS-18	4	
11		Screw M5x84mm Hex Hd	4	
12	X08114	Ball Bearing	1	
13	X20031	Screen	1	
14		Rivet	2	
15	X10054	Transmission Cover, Rear	1	
16	1226	Washer M6 Split Lock	4	
17	X20161	Ext. Hex Hd Screw #1/4-20x2.25", Zn	4	
18	X10051	Switch, Platinum	1	
19	X20207	Lock Washer M5, ID-5.4, OD-8.8, TH-2mm, SS-18	2	
20		Screw M5x10mm Hex Hd	2	
21	X10052	Clutch	1	
22	X20207	Lock Washer M5, ID-5.4, OD-8.8, TH-2mm, SS-18	1	
23		Screw M5x10mm Hex Hd	1	
24	X10053	Cover	1	
25		Screw M5x10mm Hex Hd	2	



SPC10 Motor Brake Components

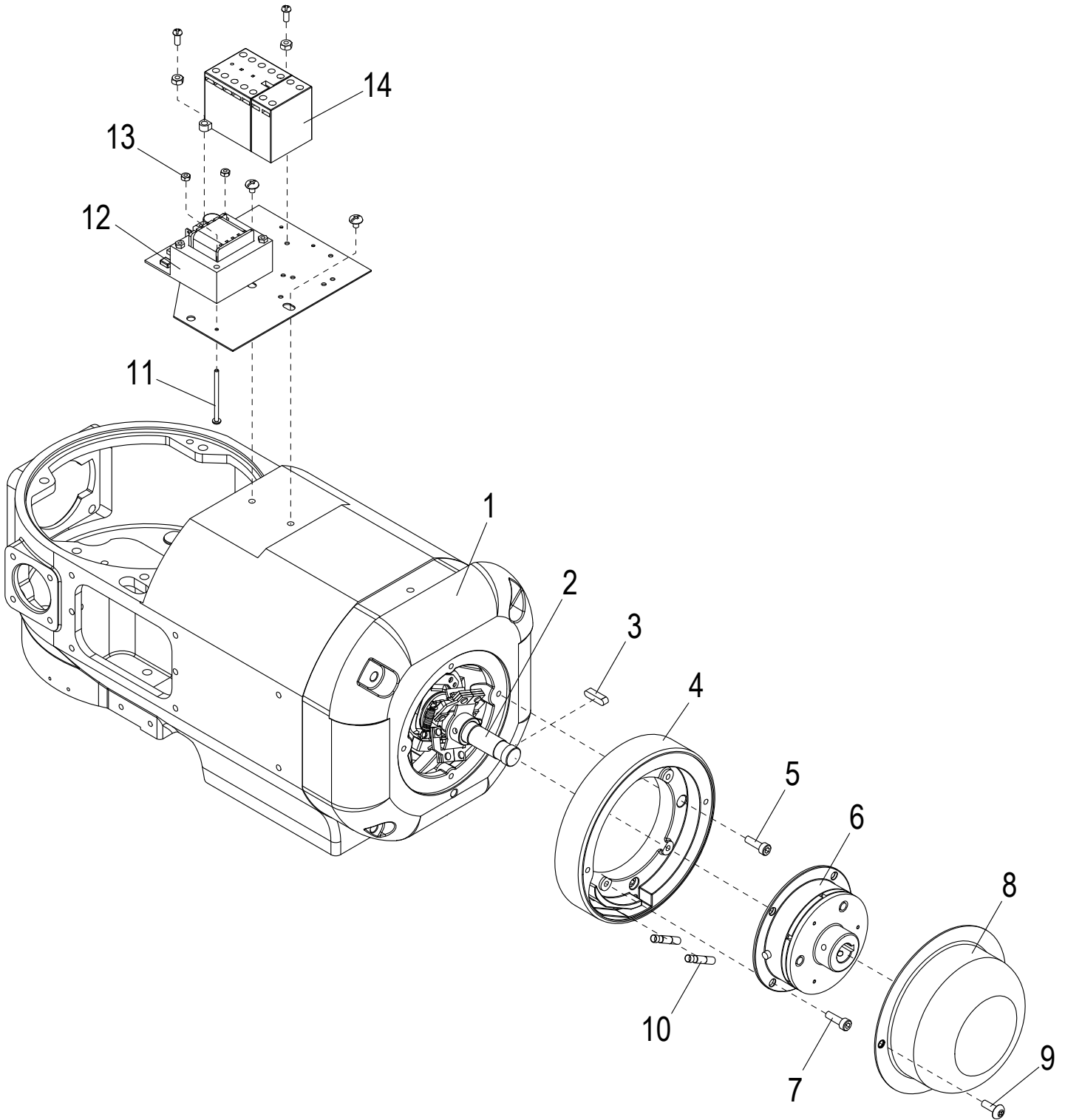



SPC10 Motor Brake Components

Item	Part Number	Description	Qty	Serial Number
1	X20054-1	Motor Cover, Rear - Mtr Brake	1	
2		Motor Shaft	1	
3		Shaft Key 5x5x17mm	1	
4	X20509	Housing, Brake	1	
5		Screw 3/16" Socket Hd	4	
6	X20511	Magnetic Brake	1	
7	X80F16	Screw M5x12mm Hex Hd - SS	4	
8	X20510	Cover, Magnetic Brake	1	
9		Screw M5x10mm Button Hd	2	
10		Connector	2	
11		Screw M3x34mm Round Hd	2	
12	X20512	Electronic Board	1	
13		Nut M3 Hex	2	
14	X20513	Auxiliary Contact Block	1	

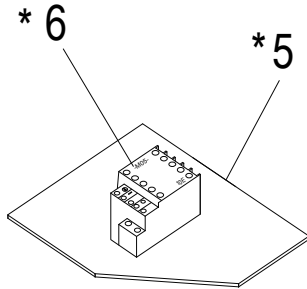
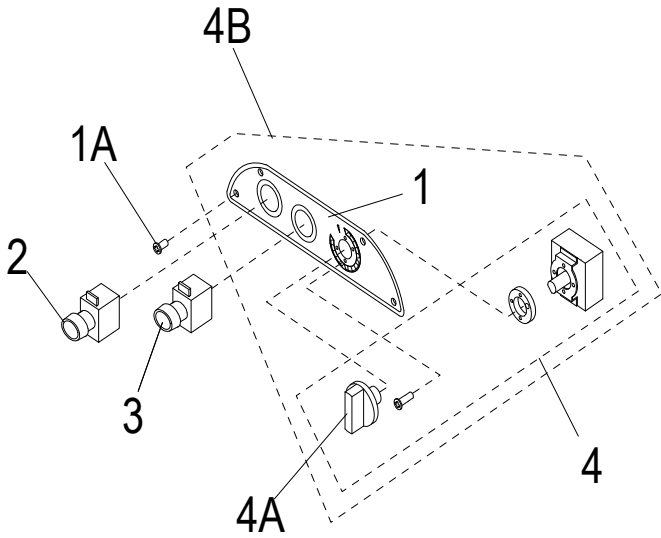

*ONLY USED ON MODELS WITH INTERNAL ELECTRICAL SYSTEM.

MANUAL TIMER

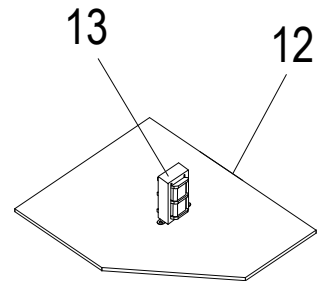
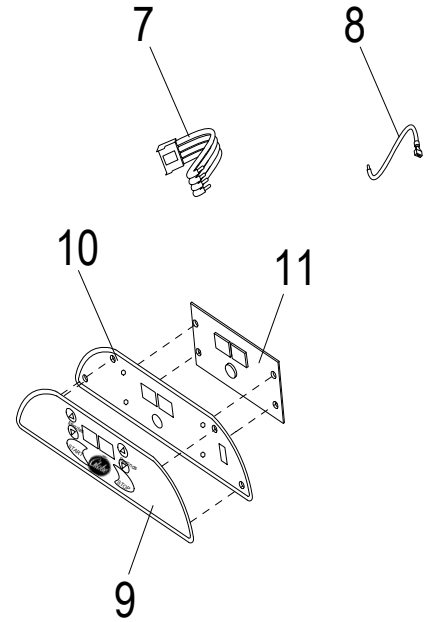

DIGITAL TIMER



SPC10 Manual Lift Controls

Item	Part Number	Description	Qty	Serial Number
1	X10002	Control Panel	1	
1A	X10179	Screw M4x10mm Truss Hd - Control Panel Mounting	4	
2	X10050	Emergency Stop Button	1	
3	X10049	Start Button	1	
3A	X10049-1	Boot, Start/Stop Switch Button	Not Shown	2
4	X10137	Timer Assembly With Knob	(Incl. item 4A)	1
4A	X10137-1	Timer Knob		1
4B	X10296	Timer Assy W/Control Panel	(Incl. items 1 & 4)	1
5		Contactator Mounting Plate	Int. Elect. Sys. Only	1
6	X10028ABB	Contactator, 12V, 300VAC	Int. Elect. Sys. Only	1
7	X00675	4 Wire Harness With Connector		1
8	X00676	Single Wire With Quick Connect		2
9	X00565	Switch, Membrane		1
10	X01336	Aluminum Panel		1
11	X00568	Control Board		1
12		Mounting Plate		1
13	X00569	Control Transformer Assembly		1
14	X00570	Control Transformer Fuse	Not Shown	1



SPC10 Wiring Diagram - 120V Single Phase

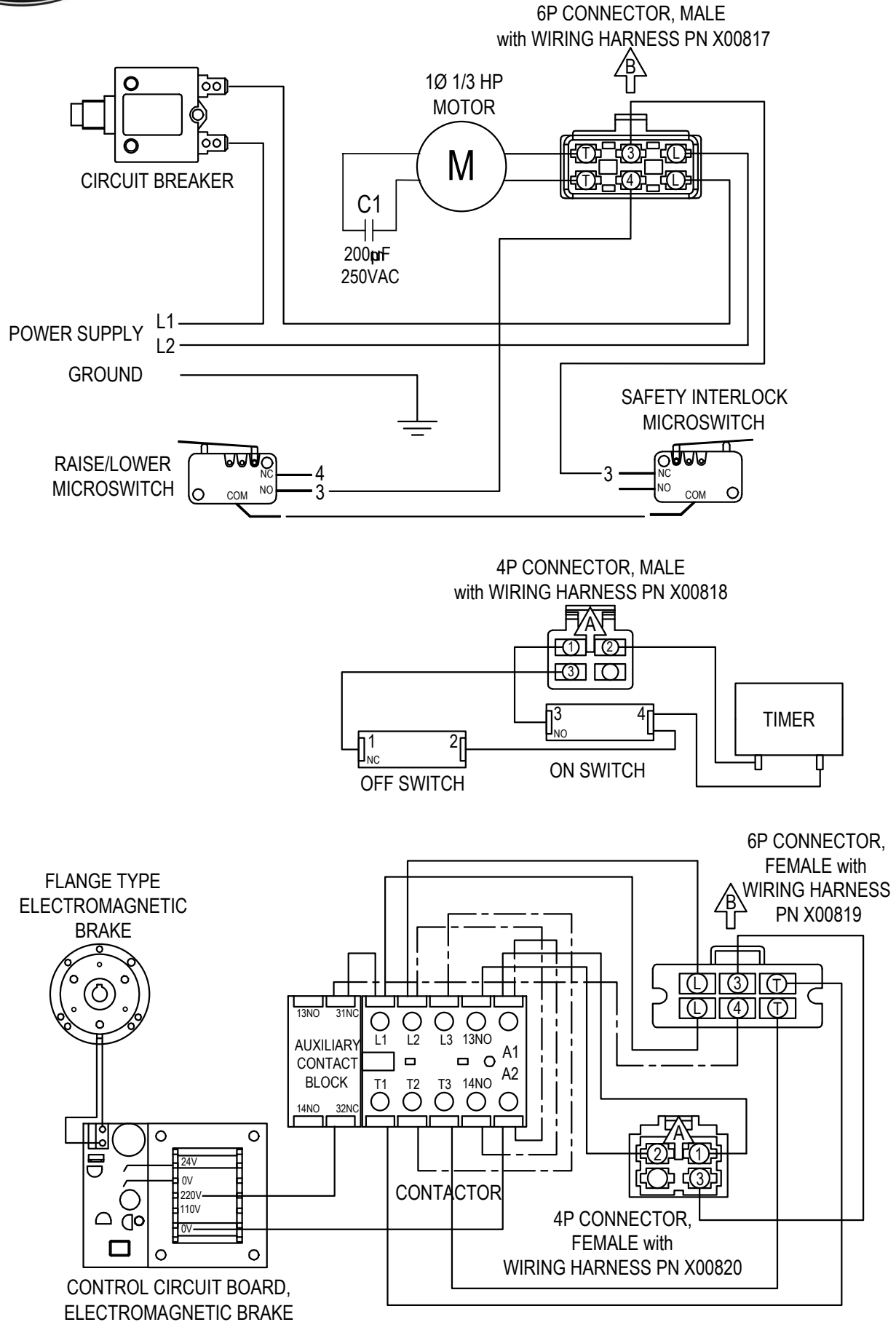



SPC10 Wiring Diagram - 120V Single Phase

