

Parts Catalog



SPC20

Mixer

Model: SPC20

10/02/2019 Rev. B

IMPORTANT!

TO EXPEDITE SHIPMENT OF PARTS, ALWAYS SPECIFY MODEL, REV,
PART NUMBER, AND SERIAL NUMBER OF UNIT.

GLOBE FOOD EQUIPMENT COMPANY

2215 East River Road
Dayton, Ohio 45439

Parts Department

Toll Free 1-800-745-6238 · Fax (937) 290-0585

E-Mail: info@globefoodequip.com

Website: www.globefoodequip.com

Not for resale

Table of Contents

Description	Page
SPC20 Base Components	4
SPC20 Head Components	8
SPC20 Hub Assembly Components	10
SPC20 Planetary Components	12
SPC20 Gearbox Components	14
SPC20 Motor Components	18
SPC20 Motor Brake Components	20
SPC20 Manual and Digital Timer	22
SPC20 Wiring Diagram - 120V Single Phase - Prior	24
SPC20 Wiring Diagram - 120V Single Phase - Post	25



SPC20 Base Components

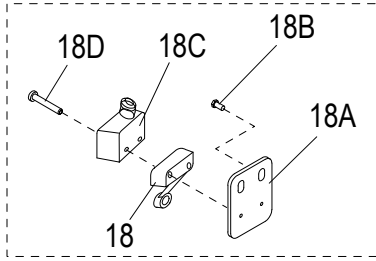

EXTERNAL ELECTRICAL SYSTEM.
PRIOR TO S/N 7212460.

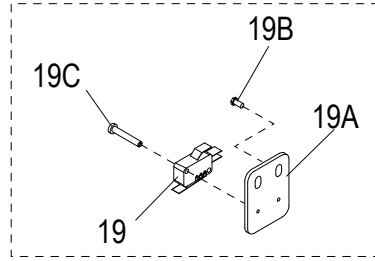

*INTERNAL ELECTRICAL SYSTEM
STARTING WITH S/N 7212461.

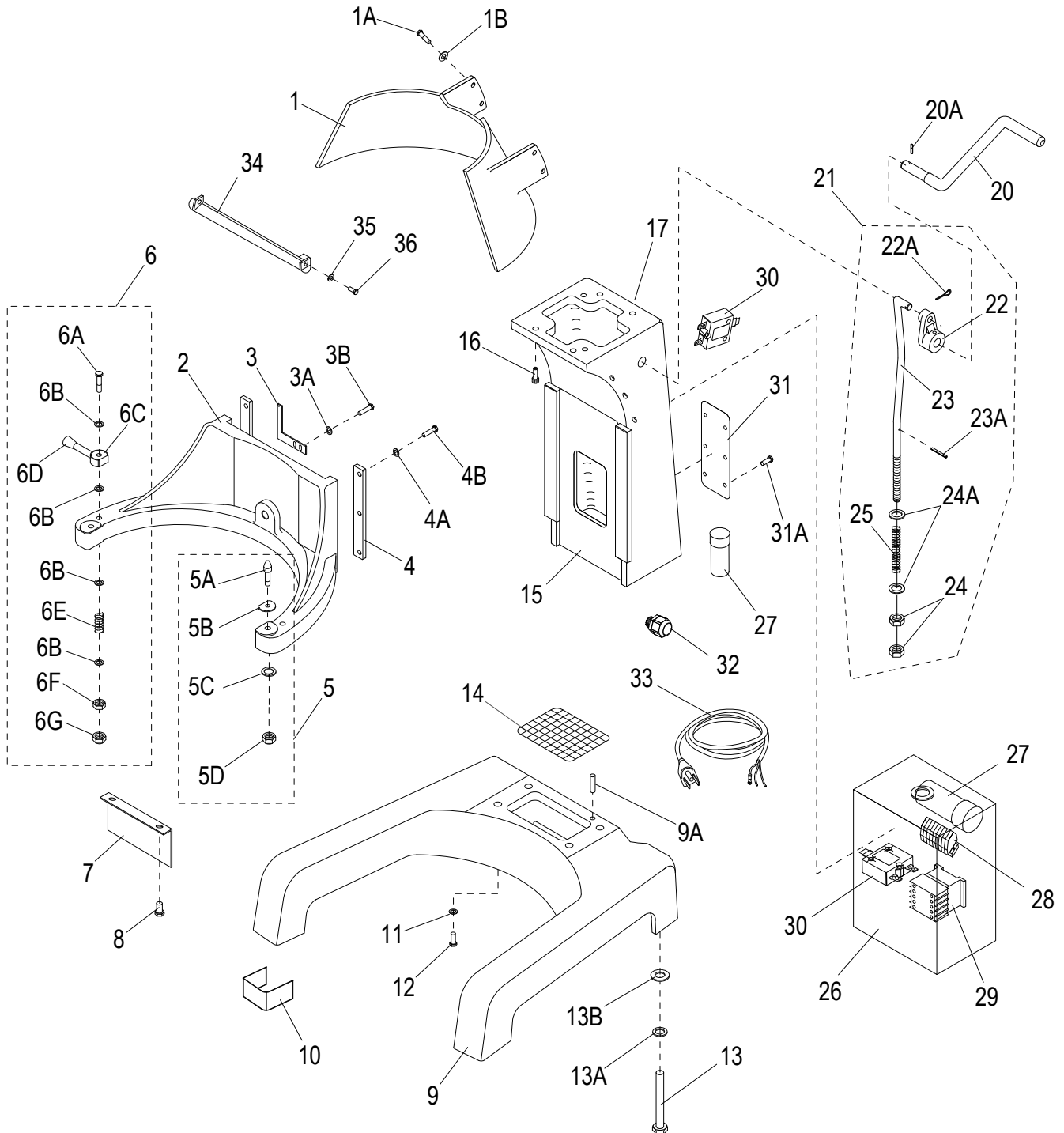



SPC20 Base Components

Item	Part Number	Description	Qty	Serial Number
1	X20023	Rear Guard	1	
1A		Screw M6x14mm Hex Hd	4	
1B		Washer M6 Flat	4	
2	X20021-DG	Bowl Cradle	1	
3	X10190	Touch Mass	1	
3A		Washer M4 Split Lock	2	
3B		Screw M4x14mm Hex Hd	2	
4	X20022	Bowl Slide	2	
4A		Washer M6 Split Lock	6	
4B		Screw M6x14mm Hex Hd	6	
5	X20087	Dowel Screw Assembly (Incls. items 5A-5D)	2	
5A		Dowel Screw	2	
5B	X01759	Flat Washer M8, ID-8.4, OD-24, TH-2mm	2	
5C	H00335	Lock Washer M8, ID-8.4, OD-15, TH-0.8mm Zn	2	
5D	X10088	Cap Nut M8-1.25, OD-13, TH-15mm Zinc	2	
6	X10020	Bowl Clamp Assembly (Set/2)	1	
6A	X20086	Ext. Hex Hd Screw M8-1.25x80mm, Zn	2	
6B	X10189	Washer M8 Flat	8	
6C	X10020-1	Bowl Clamp (Set/2)	1	
6D		Bowl Clamp Handle	2	
6E		Spring	2	
6F		Nut M8 Hex	2	
6G		Nut M8 Acorn	2	
7		Cover, Cradle	1	
8	X40056	Truss Hd Screw PHH M6-1.0x10mm, SS-18	2	
9	X20024-DG	Mixer Base	1	
9A		Dowel Pin Ø8x16mm	2	
10	X10136	Front/Rear Rubber Feet (Set/4)	4	
11	X10034	Washer M10 Flat	4	
12		Screw M10x40mm Hex Hd	4	
13	X10025	Ext. Hex Hd Screw M10-1.5x60mm, Zinc	4	
13A		Washer M10 Split Lock	4	
13B	X10034	Washer M10 Flat	4	
14	X20031	Screen	1	
15	X20035-1-DG	Mixer Column	0	
16	X08077	Ext. Hex Hd Screw M8-1.25x20mm, Zinc	4	
17	X91014	Label, Hazardous Voltage (Not Shown)	1	
18	X10085	Microswitch Ext. Elect. Sys.	1	->7212460
18A	X20154	Plate, Microswitch Ext. Elect. Sys.	1	->7212460
18B	X30217	Truss Hd Screw-PHH, M6-1.0x10mm, SS-18 Ext. Elect. Sys.	2	->7212460
18C	X10084	Cover, Microswitch Ext. Elect. Sys.	1	->7212460
18D	X30218	Screw M4x24mm Pan Hd & Flatwasher Ext. Elect. Sys.	2	->7212460
19	X10057	Microswitch, Interlock Int. Elect. Sys.	1	7212460 ->
19A	X30216	Bracket, Microswitch Mounting Int. Elect. Sys.	1	7212460 ->
19B	X30217	Truss Hd Screw-PHH, M6-1.0x10mm, SS-18 Int. Elect. Sys.	2	7212460 ->
19C	X30218	Screw M4x24mm Pan Hd & Flatwasher Int. Elect. Sys.	2	7212460 ->
20	X20040	Bowl Lift Arm	1	
20A	X10039	Dowel Pin Ø5x30mm	1	
21	X20037A	Bowl Lift Arm Assembly	1	
22		Bowl Lift Cam	1	
22A		Cotter Pin	1	
23		Bowl Lift Rod	1	
23A		Roll Ø3x28mm Pin	1	



SPC20 Base Components

Item	Part Number	Description	Qty	Serial Number
24	H01029	Hex Nut M10-1.5, OD-17, HT-8mm, Class 8, Zn	2	
24A		Washer M10 Flat	2	
25		Spring	1	
26	X10030	Electrical Box	1	Ext. Elect. Sys. ->7212460
26	X10030	Electrical Box	1	Int. Elect. Sys. 7212461 ->
27	X20026	Capacitor, Start - 300Mf	1	Ext. Elect. Sys. ->7212460
27	X20026	Capacitor, Start - 300Mf	1	Int. Elect. Sys. 7212461 ->
28	X10029A	Connecting Block Set	1	Ext. Elect. Sys. ->7212460
28	X10029A	Connecting Block Set	1	Int. Elect. Sys. 7212461 ->
28	X10029-2G	Connecting Block, Gray (2C)	7	
28	X10029-EC	Connecting Block End Cap	1	
29	X20028ABB	Contactator	1	->7212460
30	X20027-1	Circuit Breaker (8A)	1	
30	X20027-2	Circuit Breaker (New Style 13A)	1	
31	X10191	Cover Plate	1	->7212460
31A	X25051	Rd Hd Screw-PHH #10-24x1/4, SS-18	4	->7212460
32		Strain Relief	1	->7212460
33		Power Cord And Plug	1	->7212460
34	X20184	Front Guard, Mixer Column	1	->7212460
35		Washer M6 Flat	2	->7212460
36	X40056	Truss Hd Screw PHH M6-1.0x10mm, SS-18	2	->7212460



INTENTIONALLY LEFT BLANK PAGE



SPC20 Head Components

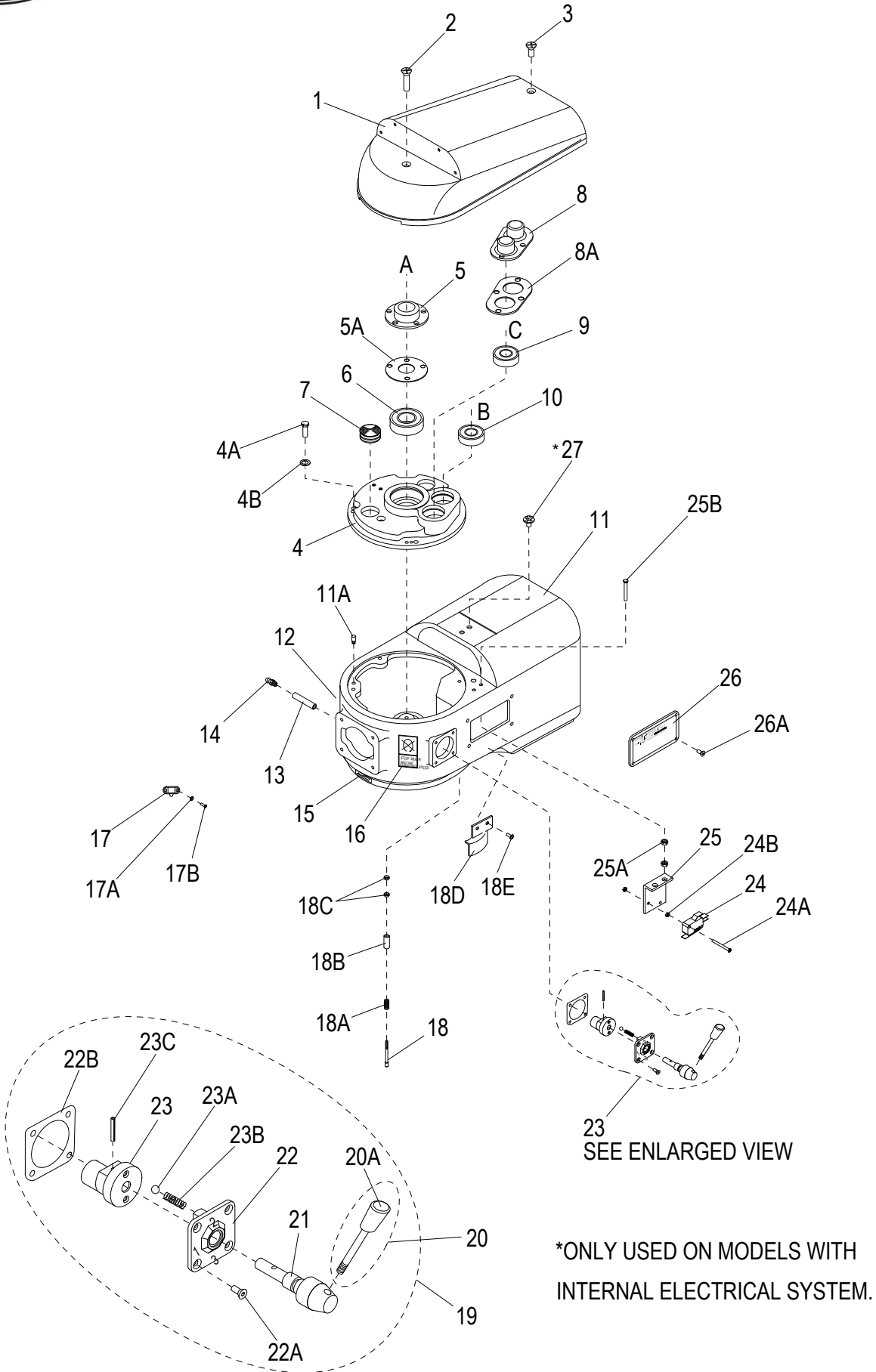



SPC20 Head Components

Item	Part Number	Description	Qty	Serial Number
1	X10001-2-DG	Transmission Cover-Front Controls	1	
1	X10001-1	Transmission Cover-Side Controls	1	
2	X10180	Flat Hd Screw-PHH 1/4"-20x1.25", Zinc	1	
3	X10181	Flat Hd Screw-PHH 1/4"-20x0.75", Zinc	1	
4	X10074	Transmission Case Lid	1	
4A		Screw M6x16mm Hex Hd	4	
4B		Washer M6 Split Lock	4	
5	X10072	Bearing Retainer Cap	1	
5A	X10187	Gasket, Bearing Retainer	1	
6	X10010	Ball Bearing	1	
7	X10073	Oil Plug	1	
8	X10071	Twin Bearing Retainer	1	
8A	X10188	Gasket, Twin Bearing Retainer	1	
9	X10068	Ball #35 Bearing	1	
10	X10068	Ball #35 Bearing	1	
11	X10059	Case, Transmission - Fixed Bowl Guard	1	
11	X10059-1	Case, Transmission - Removable Bowl Guard	1	
11A		Locating Pin Ø8xM6x10mm	2	
12	X91009	Label, Lubricate	1	
13	X10217	Grease Tube	1	
14	X10900	Grease Fitting	1	
15	X91012	Label, Arrow	1	
16	X91010	Label, Stop To Chg Gears	1	
17	X10134	Safety Guard Spring Lock	1	
17A		Washer M3 Split Lock	2	
17B	X10134B	Round Hd Screw-PHH M3-0.5x8mm, SS-18	2	
18	X10043	Touch Shaft, Brass	1	->7110208
18	X10043N	Touch Shaft, Nylon	1	7110208 ->
18A	X30095	Spring	1	
18B		Tube	1	
18C	X30186	Hex Nut M5-0.8 OD-8, TH-4mm, Zinc	2	
18D	X20516	Cover, Touch Shaft (Removable Bowl Guard)	1	
18E		Screw M5x8mm Truss Hd	2	
19	X10045-48	Gear Shift Lever Assembly	1	
20	X10045	Gear Shift Lever Assy With Knob	1	
20A	X10045-1	Knob, Gear Shift	1	
21		Shaft	1	
22		Cover	1	
22A	X25166	Flat Hd Screw-PHH M5-0.8x16mm, Zinc	4	
22B	X10199	Gasket	1	
23		Shaft Bias	1	
23A		Roller	2	
23B		Spring	2	
23C		Roll Ø3x28mm Pin	1	
24	X10057-1	Microswitch, Interlock	1	
24A		Screw M3x12mm Switch Mounting	2	
24B		Nut M3 Hex	4	
25	X10058	Bracket, Microswitch	1	
25A		Nut M6 Hex	4	
25B		Screw M6x40mm Hex Hd - Bracket Mounting	2	
26	X10055	Plate, Warning	1	
26A		Screw M4x6mm Pan Hd	4	
27	X10131	Rd Hd Screw-PHH #10-24x3/8", Zinc	1	Int. Elec. Sys. 7212460 ->



SPC20 Hub Assembly Components

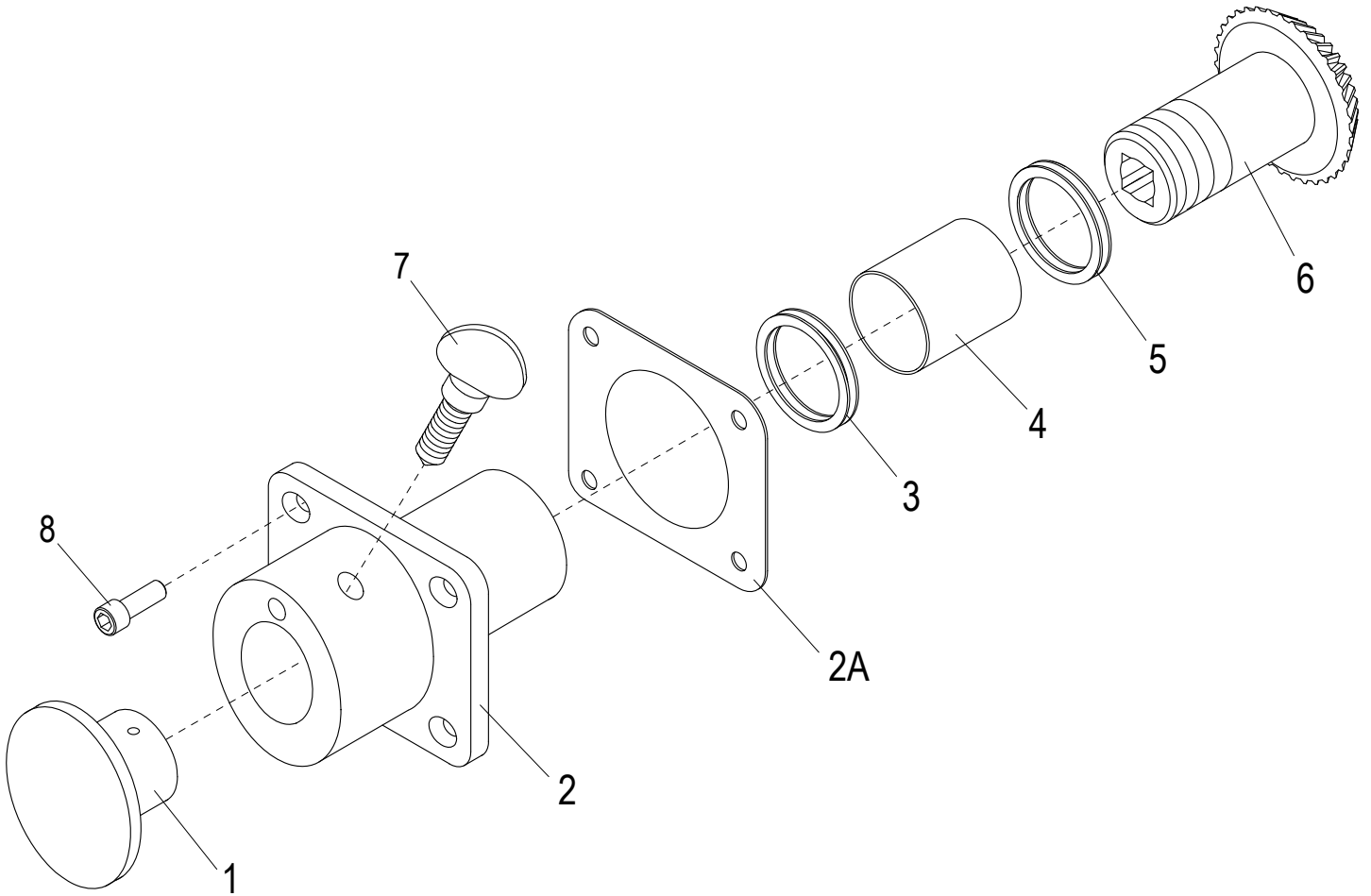



SPC20 Hub Assembly Components

Item	Part Number	Description	Qty	Serial Number
1	X10007	Attachment Hole Plug	1	
2	X10006-DG	Attachment Hub	1	7222689 ->
2A		Gasket	1	
3	X10089	Oil 45x35x8mm Seal	1	
4	X10075	Bearing	1	
5	X10004	Thrust Washer ID-36, OD-47, TH-0.5mm	2	
6	X10003	Level Drive Gear (35T)	1	
7	X10005	Thumb Screw 1/2-13x3/4"	1	
8	X80B52	Socket Hd Cap Screw M6-1.0x20mm, B.O.	4	

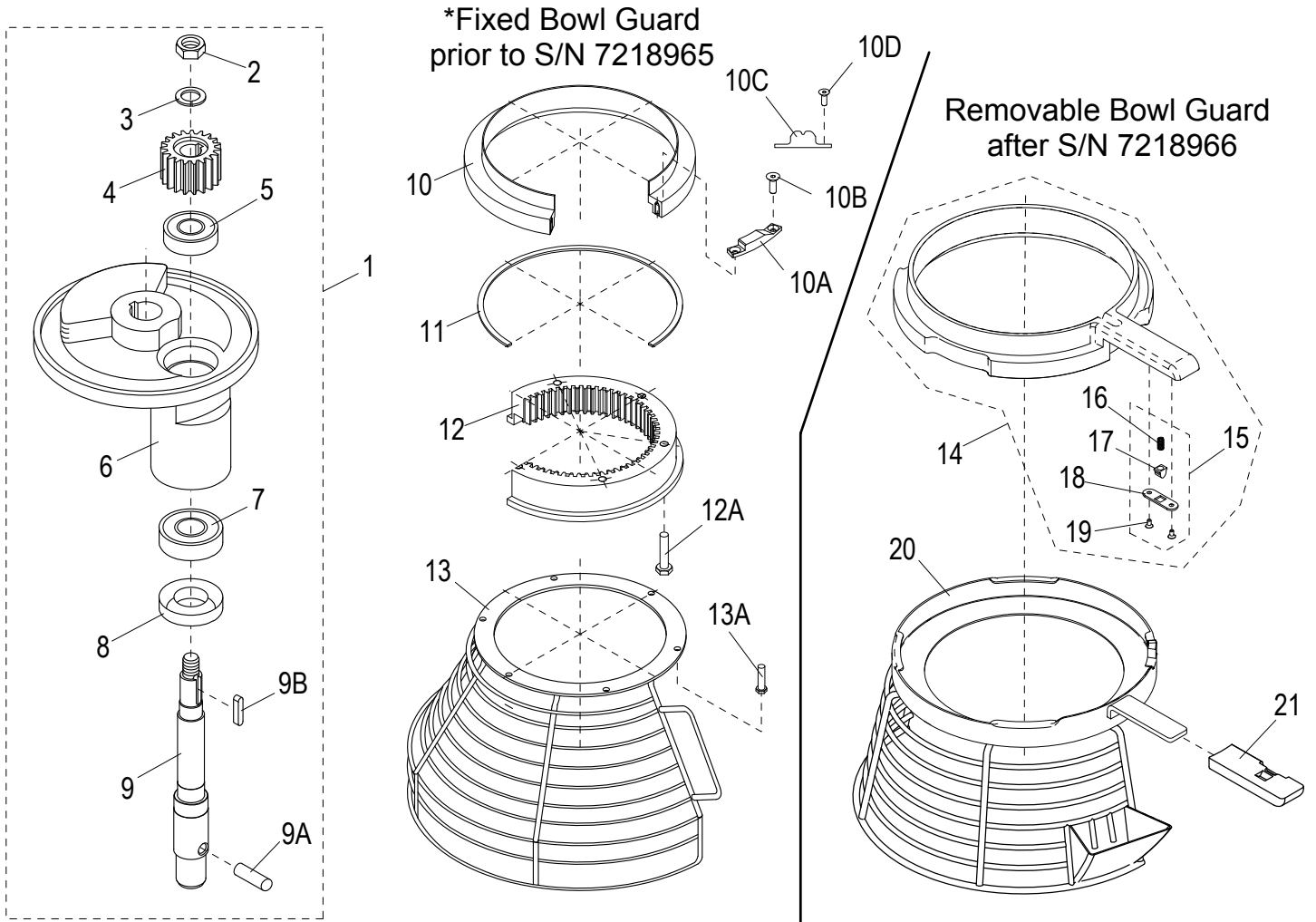



SPC20 Planetary Components

Item	Part Number	Description	Qty	Serial Number	
1	X10008-82	Complete Planetary Assembly	1		
2	X10008	Hex Nut M12-1.25, OD-19, HT-10mm, Zinc	1		
3	X80B05	Lock Washer M12, ID-12.7, OD-21.1, TH-2.5mm, SS	1		
4	X10009	Pinion, Beater (19T)	1		
5	X10010	Ball Bearing	1		
6	X10011-DG	Planetary Holder	1		
7	X10012	Ball Bearing	1		
8	X10013	Oil Seal	1		
9	X10015	Planetary Shaft	1		
9A	X10080	Dowel Pin	1		
9B	X10014	Key H-5xW-5xL-17mm, Round Ends	1		
10	X10076	Slide Sheath	Used with *	1	->7110208
10	X10076P	Slide Sheath, Molded	0	7110208	->
10A	X10041	Touch Mass	*	1	->7218965
10B	X10042	Flat Hd Screw-Phillips M4-0.7x10mm, Zn	*	2	->7218965
10C	X10135	Safety Guard Spring Lock Fixture	*	1	->7218965
10D		Screw M4x10mm Round Hd	*	2	->7218965
11	X10077	Teflon Mat	1	->7218965	
12	X10078	Planetary Internal Gear (63T)	1	->7218965	
12A	X10082	Screw 1/4-20 x 1.25" Socket Hd	6	->7218965	
13	X20079/81	Front Interlock Guard Assembly	1	->7218965	
13A	X10083	Ext. Hex Hd Screw M5-0.8x10mm, SS	6	->7218965	
14	X200S2	Plastic Slide Sheath, Removable Safety Guard	1	7218966	->
15	X200S3	Spring Plunger Hardware Kit	1	7218966	->
16		Spring	1	7218966	->
17		Plunger	1	7218966	->
18		Plate, Plunger Retention	1	7218966	->
19		Screw M3x8mm Flat Hd	2	7218966	->
20	X200S1	Bowl Guard Assembly, Stainless Steel	1	7218966	->
21	X20504	Handle, Plastic - Removable Safety Guard	1	7218966	->



SPC20 Gearbox Components

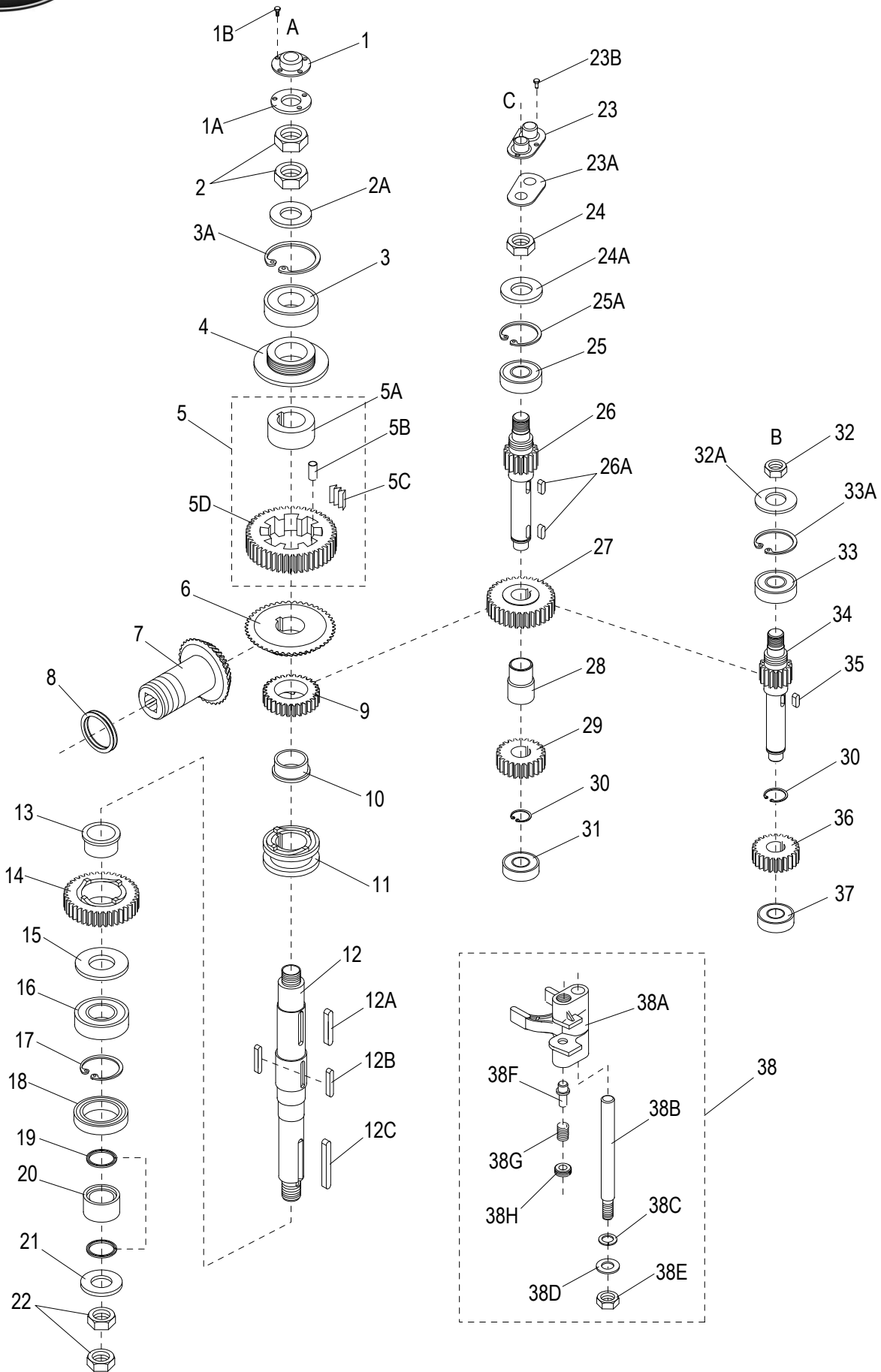



SPC20 Gearbox Components

Item	Part Number	Description	Qty	Serial Number
1	X10072	Bearing Retainer Cap	1	
1A	X10187	Gasket, Bearing Retainer	1	
1B	X10133	Pan Hd Screw-PHH M6-1.0x10mm, SS	4	
2	X10132	Thin Hex Nut 1/2-20, OD-1/2", TH-11/64" Zn	2	
2A		Washer 1/2" Flat	1	
3	X10010	Ball Bearing	1	
3A		Retaining Ring	1	
4	X10090	Lead-In Oil Pad	1	
5	X10091-94	Slow Speed Gear Assembly	1	
5A	X10091	Bushing	1	
5B		Dowel Ø8x16mm Pin	1	
5C	X10093	Slice Spring	1	
5D		Gear, Slow Speed (46T)	1	
6	X10095	Gear, Bevel (46T)	1	
7	X10003	Level Drive Gear (35T)	1	
8	X10004	Thrust Washer ID-36, OD-47, TH-0.5mm	1	
9	X10096	Gear, Clutch (29T)	1	
10	X10097	Bushing, Clutch	1	
11	X10110	Sleeve, Clutch	1	
12	X10107	Drive Shaft	1	
12A	X10098	Key H-6xW-6xL-28mm, Round Ends	1	
12B	X10109	Shaft Key 5x5x27mm	1	
12C	X10108	Shaft Key 6x6x45mm	1	
13	X10097	Bushing, Clutch	1	
14	X10100	Gear, Clutch (38T)	1	
15	X10101	Washer, Stepped	1	
16	X10102	Ball Bearing	1	
17	X20214	Int. Retaining Ring ID-2", OD-2.210", TH-0.062", B.O.	1	
18	X10105	Oil Seal	1	
19	X10103	O-Ring 28x22x3mm	2	
20	X10104	Guard, Oil Bushing	1	
21		Washer M20 Flat	1	
22	X10106	Thin Hex Nut 3/4"-16, OD-1-1/8", HT-27/64", Zn	2	
23	X10071	Twin Bearing Retainer	1	
23A	X10188	Gasket, Twin Bearing Retainer	1	
23B	X10131	Rd Hd Screw-PHH #10-24x3/8", Zinc	4	
24	X10130	Thin Hex Nut 3/4"-16, OD-1-18", HT-27/64", Zn	1	
24A		Washer 3/8" Flat	1	
25	X10068	Ball #35 Bearing	1	
25A		Retaining Ring	1	
26	X10129	Transmission Shaft (15T)	1	
26A	X10128	Key H-5xW-5xL-14mm, Round Ends	2	
27	X10126	Gear (32T)	1	
28	X10122	Bushing, Spacer	1	
29	X10121	Gear (24T)	1	
30	X10120	Retaining Ring STW-19	2	
31	X10117	Drive Shaft Upper Ball Bearing	1	
32	X10125	Thin Hex Nut 3/8-24, OD-9/16", TH-7/32", Zn	1	
32A		Washer M10 Flat	1	
33	X10068	Ball #35 Bearing	1	
33A		Retaining Ring #35	1	
34	X10124	Shaft, Master (15T)	1	
35	X10123	Key H-5xW-5xL-18mm, Round Ends	1	



SPC20 Gearbox Components

Item	Part Number	Description	Qty	Serial Number
36	X10118	Worm Wheel (29T)	1	
36	X10118-24T	Worm Wheel (24T)	1	
37	X10117	Drive Shaft Upper Ball Bearing	1	
38	X10111-116	Yoke Shifter Assembly	1	
38A		Yoke Shifter	1	
38B		Guide, Rod Shifter	1	
38C		Washer 3/8" Split Lock	1	
38D		Washer 3/8" Flat	1	
38E		Nut 3/8-16 Stop	1	
38F		Plunger, Yoke Shifter	1	
38G		Spring, Retainer	1	
38H		Spring, Yoke Shifter	1	



INTENTIONALLY LEFT BLANK PAGE



SPC20 Motor Components

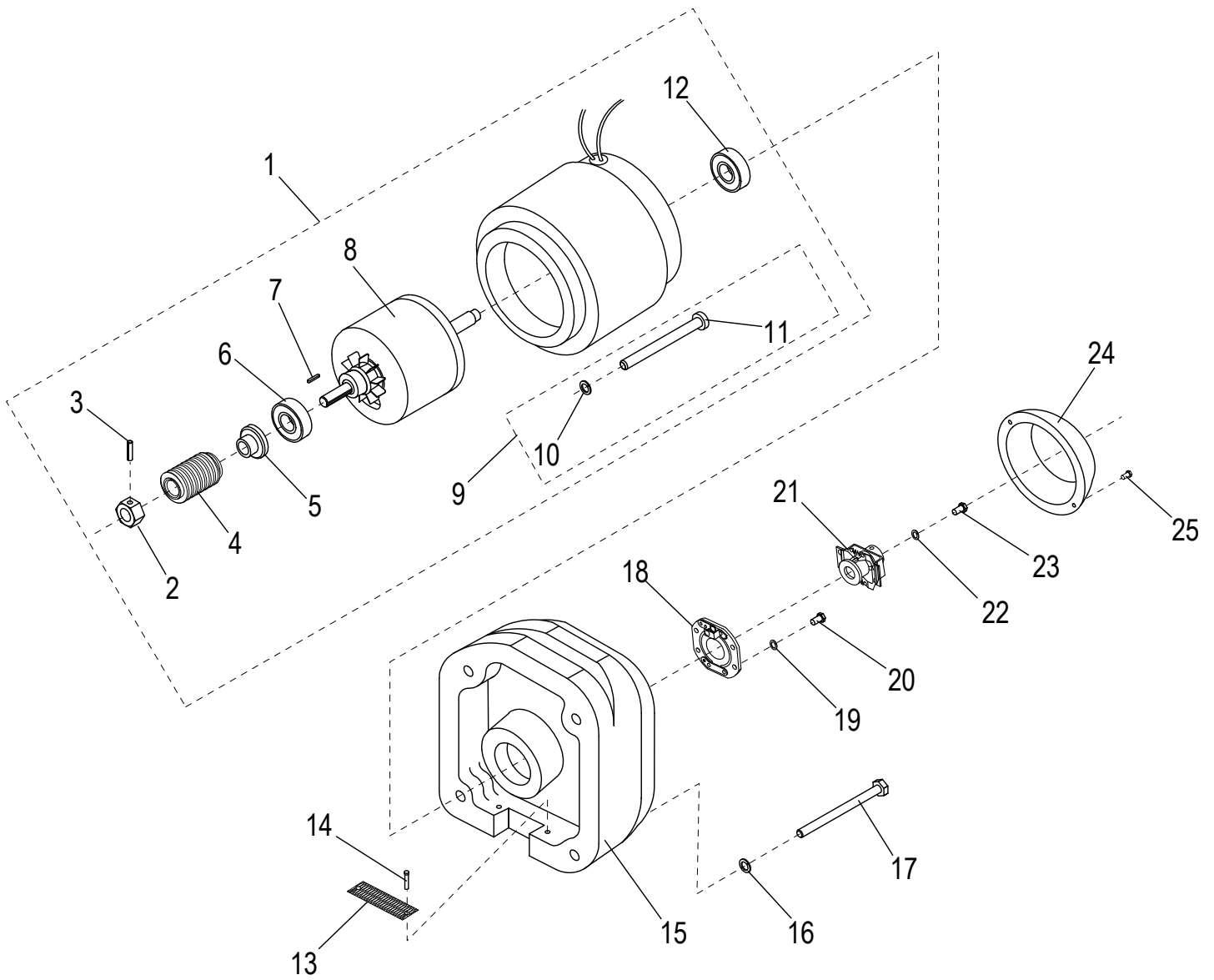



SPC20 Motor Components

Item	Part Number	Description	Qty	Serial Number
1	X20060-67C	Motor Assembly, 1/2 HP - Motor Brake	1	
2	X20066	Hex Nut 7/16, OD-11/16", TH-3/8", Zn	1	
3	X20067	Roll Pin M3x16mm	1	
4	X20065	Worm (5T)	1	
5	X20060	Spring Shock Absorber	1	
6	X08114	Ball Bearing	1	
7	X20202	Key H-3xW-3xL-18mm, Round Ends	1	
8		Motor Shaft	1	
8		Motor Coil	1	
9	X20206-207	Screw And Lock Washer Set	1	
10		Washer M5 Split Lock	4	
11		Screw M5x55mm Hex Hd	4	
12	X10010	Ball Bearing	1	
13	X20031	Screen	1	
14		Rivet	2	
15	X10054	Transmission Cover, Rear	1	
16	1226	Washer M6 Split Lock	4	
17	X20161	Ext. Hex Hd Screw #1/4-20x2.25", Zn	4	
18	X10051	Switch, Platinum	1	
19	X20207	Lock Washer M5, ID-5.4, OD-8.8, TH-2mm, SS-18	2	
20		Screw M5x10mm Hex Hd	2	
21	X10052	Clutch	1	
22	X20207	Lock Washer M5, ID-5.4, OD-8.8, TH-2mm, SS-18	1	
23		Screw M5x10mm Hex Hd	1	
24	X10053	Cover	1	
25		Screw M5x10mm Hex Hd	2	
26	X20063	Fan (Not Shown)	1	



SPC20 Motor Brake Components

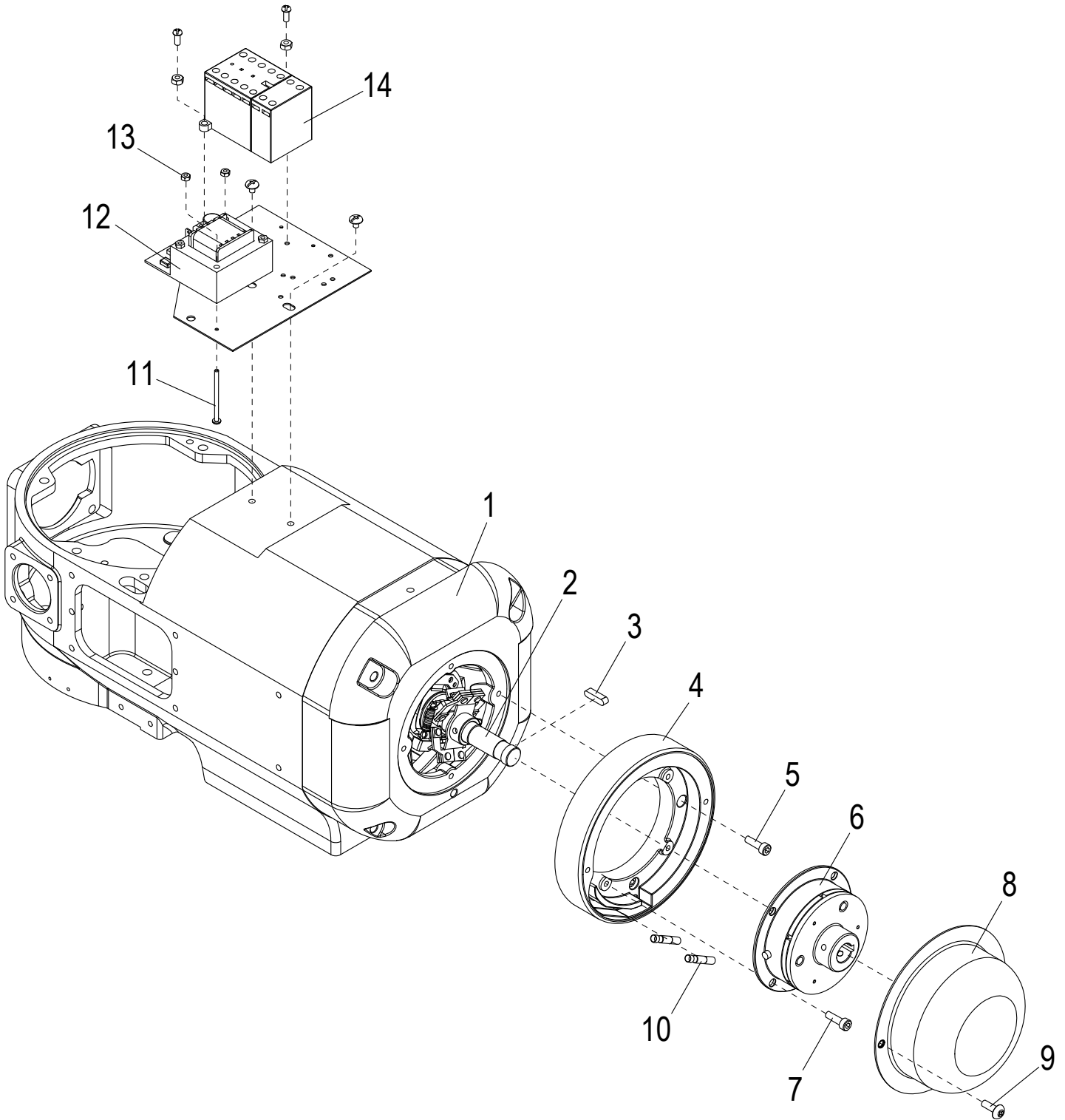



SPC20 Motor Brake Components

Item	Part Number	Description	Qty	Serial Number
1	X20054-1	Motor Cover, Rear - Mtr Brake	1	
2		Motor Shaft	1	
3	X10014	Key H-5xW-5xL-17mm, Round Ends	1	
4	X20509	Housing, Brake	1	
5		Screw 3/16" Socket Hd	4	
6	X20511	Magnetic Brake	1	
7		Screw M5x12mm Socket Hd	4	
8	X20510	Cover, Magnetic Brake	1	
9		Screw M5x10mm Button Hd	2	
10		Connector	2	
11		Screw M3x34mm Round Hd	2	
12	X20512	Electronic Board	1	
13		Nut M3 Hex	2	
14	X20513	Auxiliary Contact Block	1	

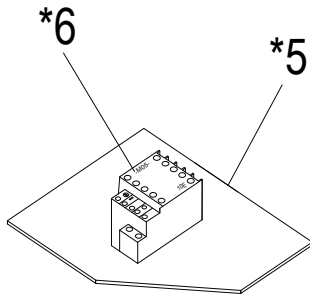
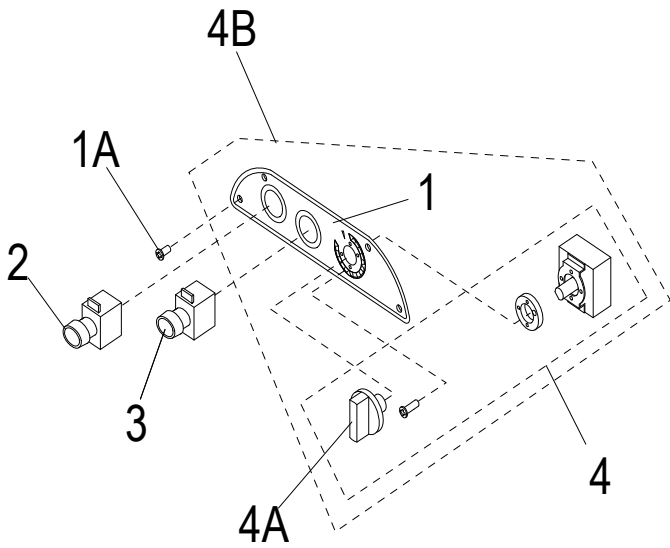

*ONLY USED ON MODELS WITH INTERNAL ELECTRICAL SYSTEM.

MANUAL TIMER

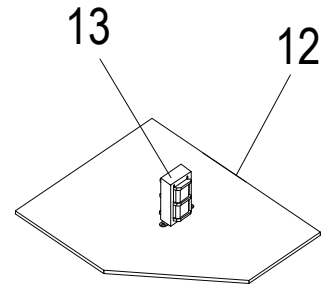
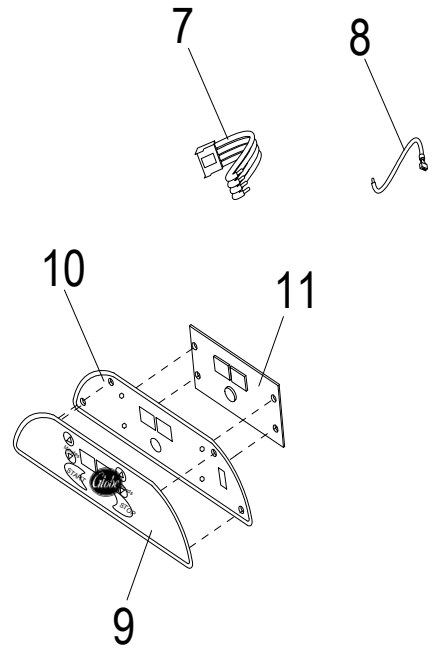

DIGITAL TIMER



SPC20 Manual and Digital Timer

Item	Part Number	Description	Qty	Serial Number
1	X10002	Control Panel	1	
1A	X10179	Screw M4x10mm Truss Hd - Control Panel Mounting	4	
2	X10050	Emergency Stop Button	1	
3	X10049	Start Button	1	
3A	X10049-1	Boot, Start/Stop Switch Button (Not Shown)	2	
4	X10137	Timer Assembly With Knob	1	
4A	X10137-1	Timer Knob	1	
4B	X10296	Timer Assy W/Control Panel	1	
5		Contacting Mounting Plate Int. Elect. Sys.	1	
6	X20028ABB	Contacting Int. Elect. Sys.	1	
7	X00675	4 Wire Harness With Connector	1	
8	X00676	Single Wire With Quick Connect	2	
9	X00565	Switch, Membrane	1	
10	X10336	Aluminum Panel	1	
11	X00568	Control Board	1	
12		Mounting Plate	1	
13	X00569	Control Transformer Assembly	1	
14	X00570	Control Transformer Fuse (Not Shown)	1	



SPC20 Wiring Diagram - 120V Single Phase - Prior

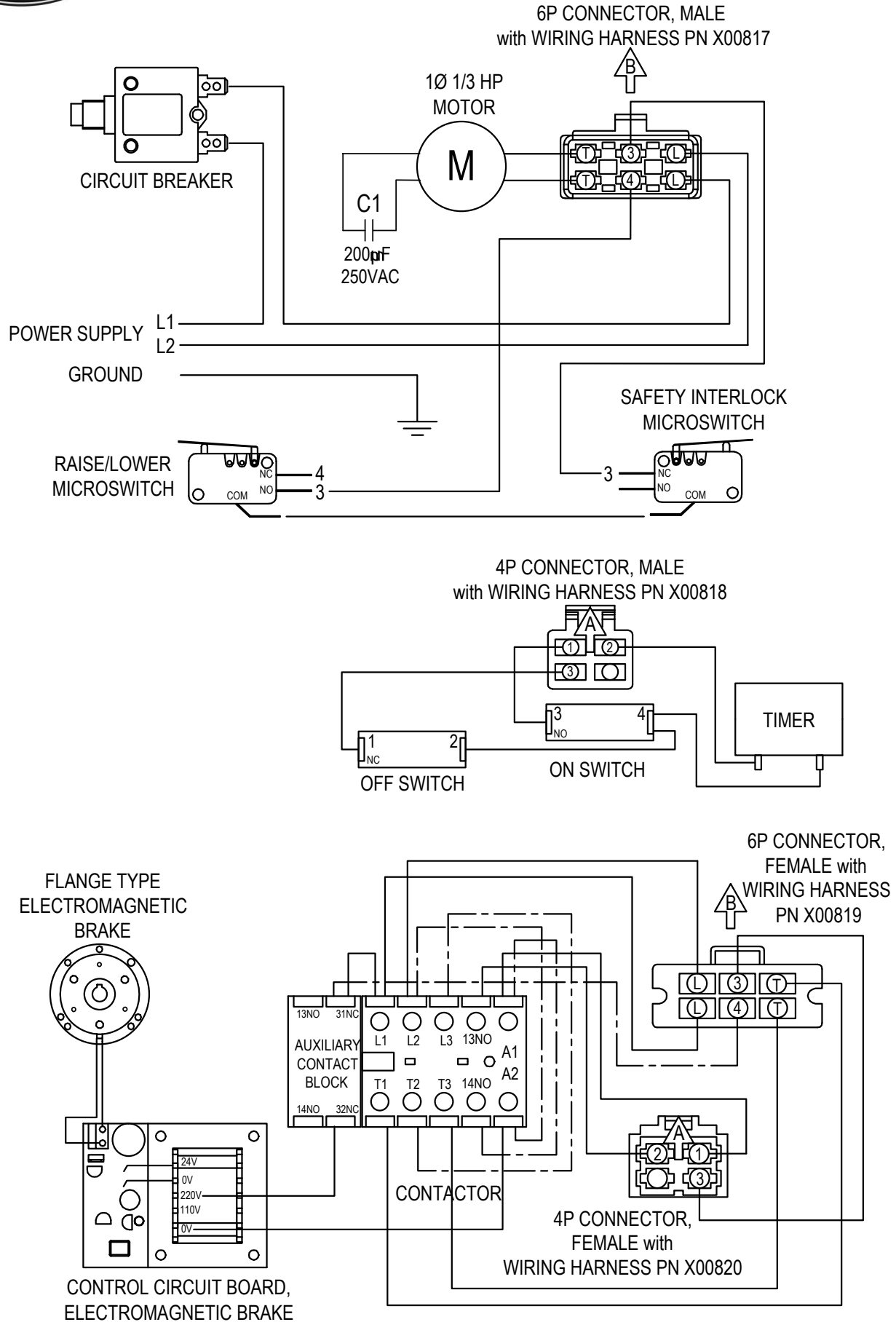



SPC20 Wiring Diagram - 120V Single Phase - Post

