

# Parts Catalog



**SPC30P**

## Mixer

**Model: SPC30P**

10/02/2019 Rev. C

IMPORTANT!

TO EXPEDITE SHIPMENT OF PARTS, ALWAYS SPECIFY MODEL, REV,  
PART NUMBER, AND SERIAL NUMBER OF UNIT.

## **GLOBE FOOD EQUIPMENT COMPANY**

2215 East River Road  
Dayton, Ohio 45439

### **Parts Department**

Toll Free 1-800-745-6238 · Fax (937) 290-0585

E-Mail: [info@globefoodequip.com](mailto:info@globefoodequip.com)

Website: [www.globefoodequip.com](http://www.globefoodequip.com)

Not for resale



# Table of Contents

Description	Page
SPC30P Base, Lever Style Components_ecr 545	4
SPC30P Head Components	8
SPC30P Hub Assembly Components	10
SPC30P Planetary Components	12
SPC30P Gearbox Components	14
SPC30P Motor Components	18
SPC30P Motor Brake Components	20
SPC30P Manual and Digital Timer	22
SPC30P Wiring Diagram, 220V Single Phase	24
SPC30P Wiring Diagram, Single Phase, Digital Timer	25



**SPC30P Base, Lever Style Components ecr 545**

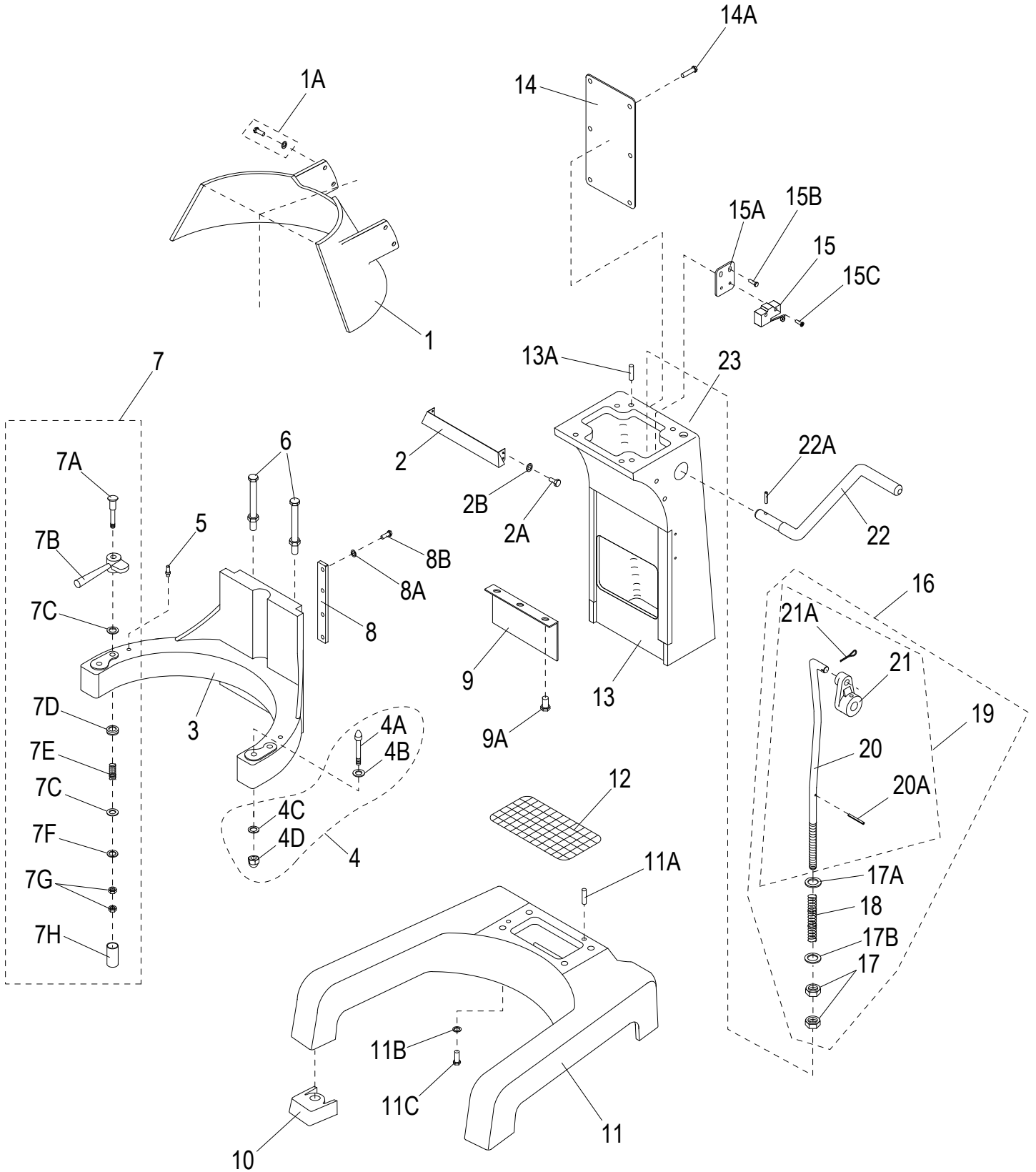



**SPC30P Base, Lever Style Components ecr 545**

Item	Part Number	Description	Qty	Serial Number
1	X30036	Guard, Rear	1	
1A	X30101	Hex Screw M8x20mm & Flat Washer	4	
2	X30102	Mixer Column Cover	1	
2A		Screw M6x10mm Hex Hd	3	
2B	X25069	Flat Washer, M6 ID-6mm, OD-24mm, TH-3mm, Thick	3	
3	X30034-DG	Bowl Cradle	1	7314991 ->
4	X30109	Dowel Screw Assembly (Incl. items 4A-4D)	2	
4A		Dowel Screw	2	
4B		Washer M12 Lock	2	
4C		Washer M12xOD30x1.0mm	2	
4D	X40110	Cap Nut, M12-1.75, OD-19mm, HT-22mm, Class 10, Zn	2	
5	X30167	Bowl Clamp Stop Pin	2	
6	X40106	Screw M10x54mm Hex Hd/Nut (Touch Shaft)	1	
7	X30033	Bowl Clamp Assembly (Set/2) (Incl. items 7A-7H)	1	
7A	X30108	Bowl Clamp Hardware Kit	2	
7B	X30033-2	Bowl Clamp (Set/2, New Style)	1	
7C		Washer M12 Flat	4	
7D		Hardware Cap Retainer	2	
7E		Spring	2	
7F		Washer M12 Split Lock	2	
7G		Nut M12 Jam	4	
7H		Hardware Cap	2	
8	X30035	Cradle Slide Guides	2	
8A	X08076	Flat Washer, M8 ID-8.4mm, OD-16mm, TH-1.6mm, Zn	8	
8B	X30069	Screw M8x30mm Hex Hd	8	
9	X30164	Cover, Cradle, S/S	1	
9A		Screw M6x14mm Hex Hd	3	
10	X30162-163	Front/Rear Rubber Feet (Set)	1	
11	X30038-DG	Mixer Base	1	7314991 ->
11A		Dowel Pin Ø8x16mm Column Locator	2	
11B	X80B05	Lock Washer M12, ID-12.7, OD-21.1, TH-2.5mm, SS	4	
11C	X80B04	Ext. Hex Hd Screw M12-1.75x40mm, B.O.	4	
12	X30037	Base Screen	1	
13	X00647	Mixer Column	1	
13A	X30178	Dowel Pin Ø8x16mm Head Locator	2	
14	X30055	Plate, Rear Cover	1	
14A	X30056	Truss Hd Screw M5-0.8x12mm, SS	6	
15	X30219	Microswitch, Bowl Lift	1	
15A	X30216	Bracket, Microswitch Mounting	1	
15B	X30217	Truss Hd Screw-PHH, M6-1.0x10mm, SS-18	2	
15C	X30218	Screw M4x24mm Pan Hd & Flatwasher	2	
16	X30211A	Bowl Lift Rod Assembly (Incl. items 17-21A)	1	
17	X30215	Hex Nut M12-1.75, OD-19mm, HT-10mm, Zn	2	
17A	X30213	Lg. Flat Washer M14, ID-15mm, OD-44mm, TH-3mm, SS	2	
17B	X01370	Washer M12 Flat	1	
18	X30214	Spring	1	
19	X01371	Bowl Lift Rod with Cam and Pin (Incl. items 20-21A)	1	
20		Bowl Lift Rod	1	
20A		Roll M4x30mm Pin	1	
21		Bowl Lift Cam	1	
21A		Cotter Pin	1	
22	X30208	Bowl Lift Arm	1	
22A	X30209	Roll M5x30mm Pin	1	



## **SPC30P Base, Lever Style Components ecr 545**

---

<b>Item</b>	<b>Part Number</b>	<b>Description</b>	<b>Qty</b>	<b>Serial Number</b>
23	X91014	Label, Hazardous Voltage	1	
24	952-12	Strain Relief, Liquid Tight (Not Shown)	1	
25	X30155	Power Cord, 110V Mixer (Not Shown)	1	



*INTENTIONALLY LEFT BLANK PAGE*



# SPC30P Head Components

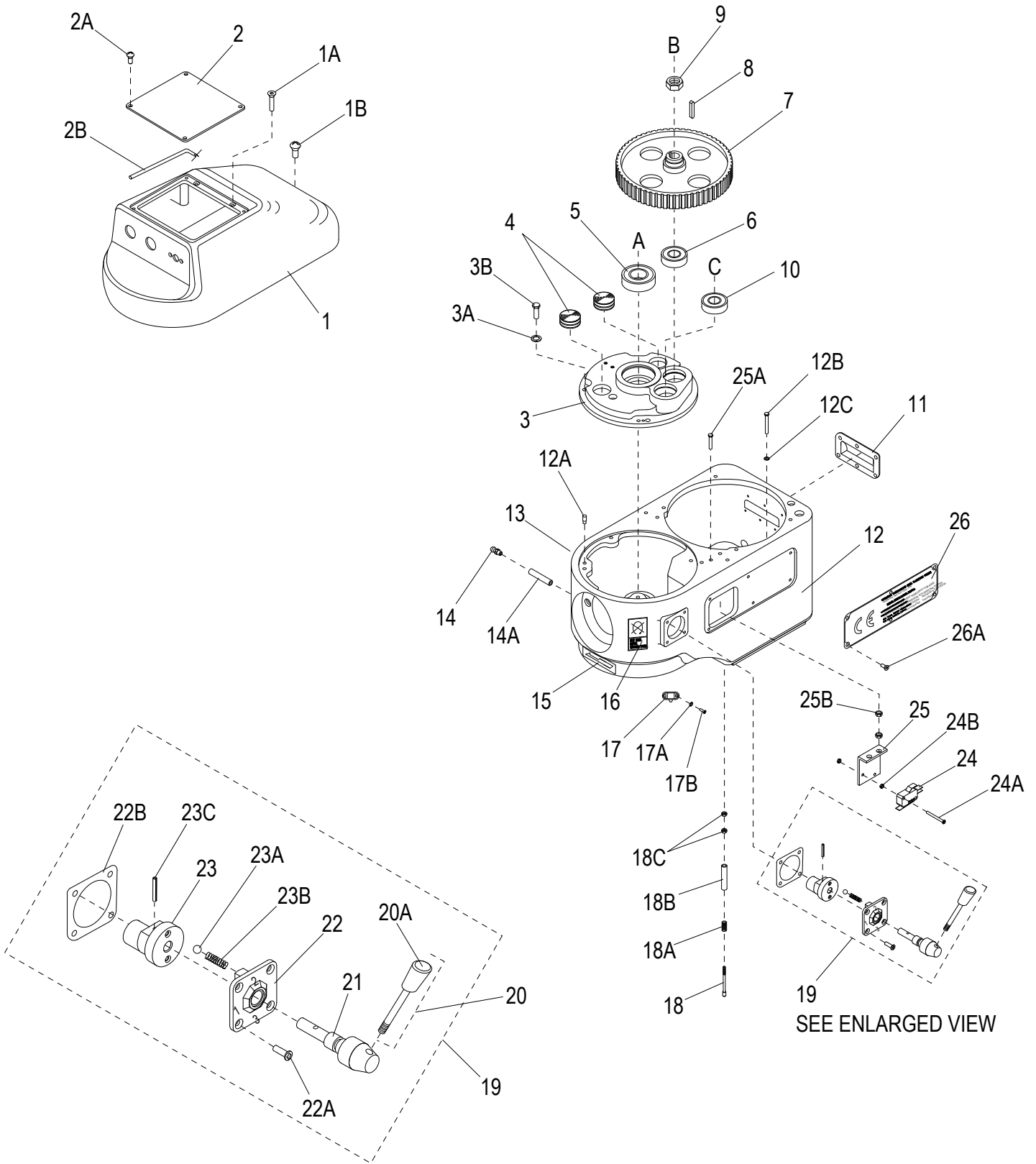





## SPC30P Head Components

Item	Part Number	Description	Qty	Serial Number
1	X30004-DG	Cover, Transmission	1	
1A	X30207	Flat Hd Screw-Socket M8-1.25x108mm, B.O.	2	
1B	X30220	Flat Hd Screw-Socket M6-1.0x90mm, B.O.	1	
2	X30002	Cover, Switch Box	1	
2A	X30001	Screw M6x10mm Truss Hd	4	
2B	X30003	Gasket	1	
3	X30077	Cover, Gear Housing	1	
3A	X30198	Lock Washer M8, ID-8.5mm, OD-12.7mm, TH-2mm	4	
3B	X30197	Ext. Hex Hd Screw M8-1.25x25mm, SS	4	
4	X10073	Oil Plug	2	
5	X30024	Ball Bearing	1	
6	X10012	Ball Bearing	1	
7	X30080	Wheel, Main Cog	1	
8	X30081	Shaft 5x5x30mm Key	1	
9	X30082	Thin Hex Nut M16-1.5, OD-24mm HT-8mm, Zn	1	
10	X10012	Ball Bearing	1	
11	X30076	Plate, Ventilation	1	
12	X30087	Transmission Case, Fixed Bowl Guard	1	
12	X30087-1	Transmission Case, Removable Bowl Guard	1	
12A		Dowel Pin, Threaded	2	
13	X91009	Label, Lubricate	1	
14	X10900	Grease Fitting	1	
14A	X10217	Grease Tube	1	
15	X91012	Label, Arrow	1	
16	X91010	Label, Stop To Chg Gears	1	
17	X10134	Safety Guard Spring Lock	1	
17A		Washer M3 Flat	2	
17B	X10134B	Round Hd Screw-PHH M3-0.5x8mm, SS-18	2	
18	X40096	Touch Shaft Assy, Brass	1	
18	X30096N	Touch Shaft, Nylon	1	
18A	X30095	Spring	1	
18B		Tube	1	
18C	X30186	Hex Nut M5-0.8 OD-8, TH-4mm, Zinc	2	
19	X30057-60	Gear Shift Lever Assembly	1	
20	X30057	Gear Shift Lever With Knob	1	
20A	X30057-1	Knob, Gear Shift	1	
21		Shaft	1	
22		Cover	1	
22A	X30179	Flat Hd Screw-Socket M8-1.0x16mmHd, Zn	4	
22B	X30059-1	Gasket	1	
23		Shaft Bias	1	
23A		Roller	2	
23B		Spring	2	
23C		Roll Ø3x28mm Pin	1	
24	X10057	Microswitch, Interlock	1	
24A	854-2	Screw, Magnet Mounting	2	
24B	854-3	Nut, Magnet Mounting	4	
25	X30062	Bracket, Microswitch	1	
25A		Screw M6x20mm Hex Hd	2	
25B		Nut M6	4	
26	X30066	Plate, Warning	1	
26A	X30065	Truss Hd Screw-Phillips M5-0.8x10mm, SS	6	



# SPC30P Hub Assembly Components

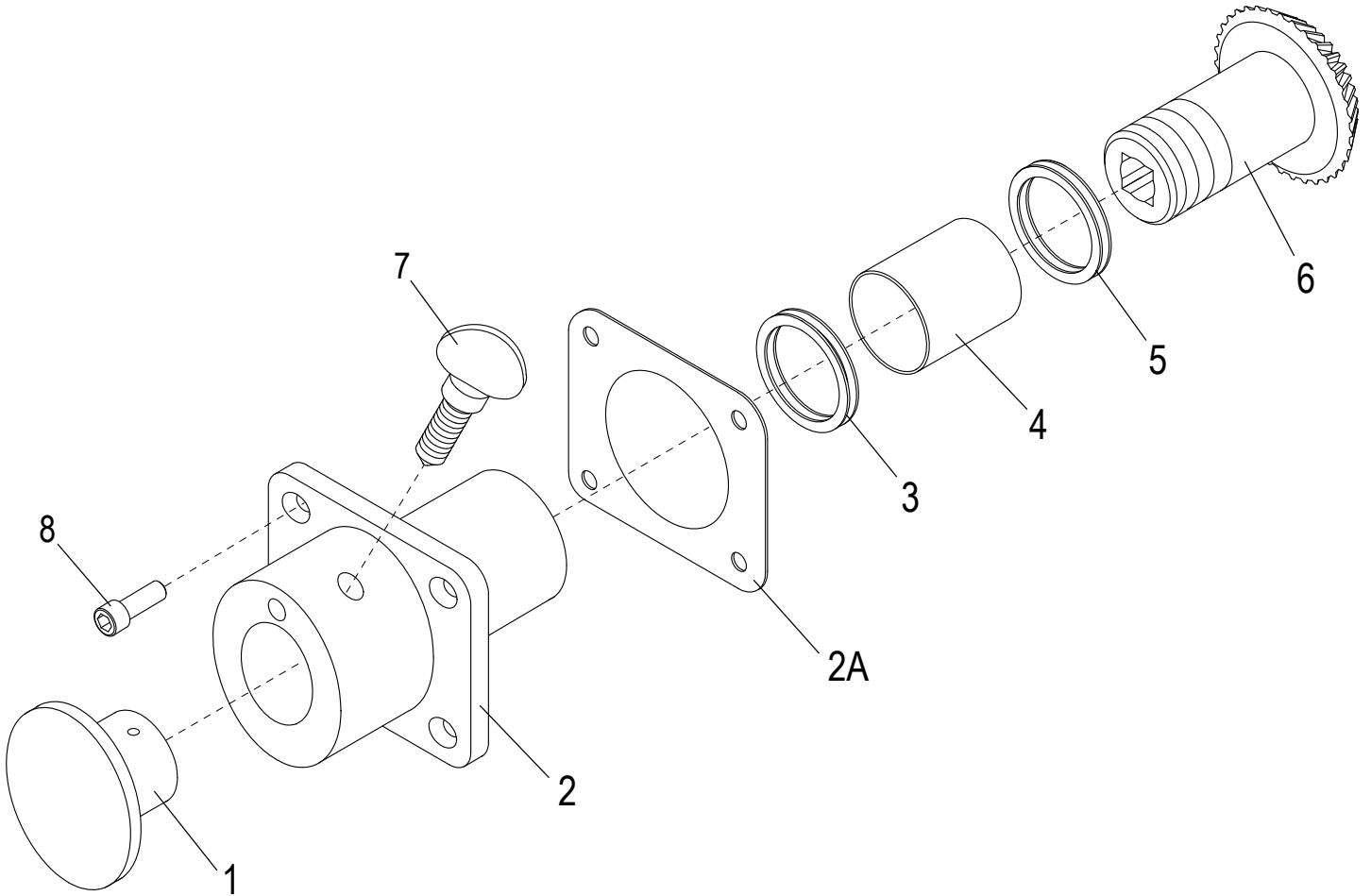



## SPC30P Hub Assembly Components

---

Item	Part Number	Description	Qty	Serial Number
1	X10007	Attachment Hole Plug	1	
2	X30017-DG	Attachment Hub	1	
2A		Gasket	1	
3	X10089	Oil 45x35x8mm Seal	1	
4	X10075	Bearing	1	
5	X30018-1	Thrust Washer ID-35mm, OD-55mm, TH-1mm	2	
6	X30014	Level Drive Gear (35T)	1	
7	X10005	Thumb Screw 1/2-13x3/4"	1	
8		Gasket	4	



# SPC30P Planetary Components

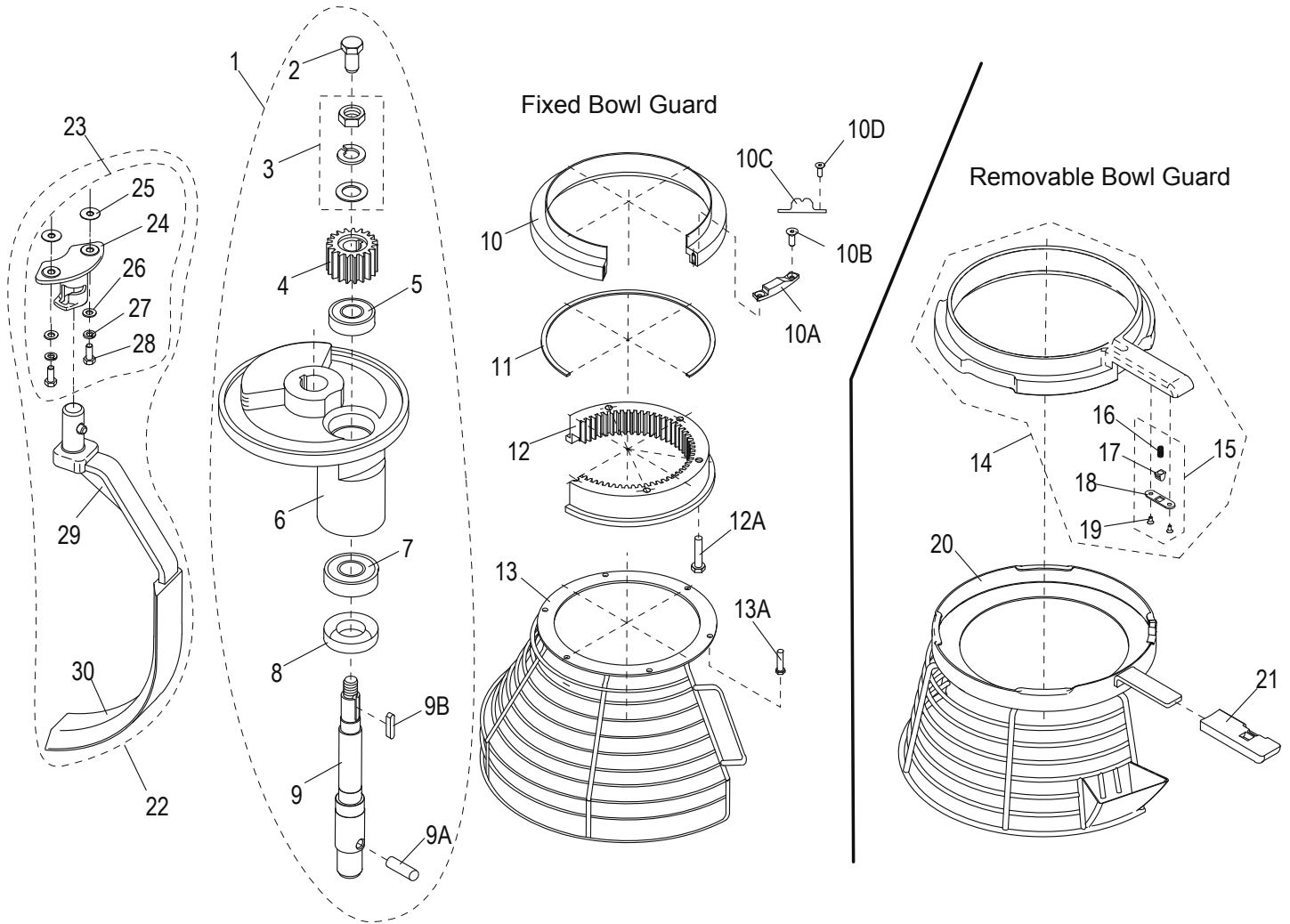



## SPC30P Planetary Components

Item	Part Number	Description	Qty	Serial Number
1	X30019-28	Complete Planetary Assembly (Incl. items 2-9B)	1	
2	X30019	Ext. Hex Hd Screw M10-1.5x25mm, B.O.	1	
3	X30020	Nut M14 Stop & Washers	1	
4	X30021	Pinion, Beater (21T)	1	
5	X10012	Ball Bearing	1	
6	X30023-DG	Planetary Shaft Holder	1	
7	X30024	Ball Bearing	1	
8	X30025	Oil Seal	1	
9	X30027	Planetary Shaft, External Thread (New Style)	1	
9		Planetary Shaft, Internal Thread (Old Style)	1	
9A	X30028	Dowel Pin M12x17mm	1	
9B	X30026	Shaft Key 5x5x24mm	1	
10	X30090P	Slide Sheath, Plastic	1	
10A	X10041	Touch Mass	1	
10B	X10042	Flat Hd Screw-Phillips M4-0.7x10mm, Zn	2	
10C	X10135	Safety Guard Spring Lock Fixture	1	
10D		Screw M4x10mm Round Hd	2	
11	X30091	Teflon Mat	1	
12	X30092	Ring Gear (67T)	1	
12A	X30099	Socket Hd Cap Screw M8-1.25x35mm, B. O.	6	
13	X30093-94	Front Interlocking Guard Assy	1	
13A	X10083	Ext. Hex Hd Screw M5-0.8x10mm, SS	6	
14	X300S2	Plastic Slide Sheath, Removable Safety Guard (Incl. items 15-19)	1	
15	X200S3	Spring Plunger Hardware Kit	1	
16		Spring	1	
17		Plunger	1	
18		Plate, Plunger Retention	1	
19		Screw M3x8mm Flat Hd	2	
20	X300S1	Bowl Guard Assembly, Stainless Steel	1	
21	X30504	Handle, Plastic - Removable Safety Guard	1	
22	XXSCRP-30	Bowl Scraper Assembly (Incl. items 23-30)	1	
23	X02000	Scraper Mounting Kit (Incl. items 24-28)	1	
24		Washer	2	
25		Scraper Mounting Hub	1	
26		Washer M8 Flat	2	
27		Washer M8 Split Lock	2	
28		Screw M8x25mm Hex Hd	2	
29		Scraper Arm	1	
30	X40515	Bowl Scraper	1	



# SPC30P Gearbox Components

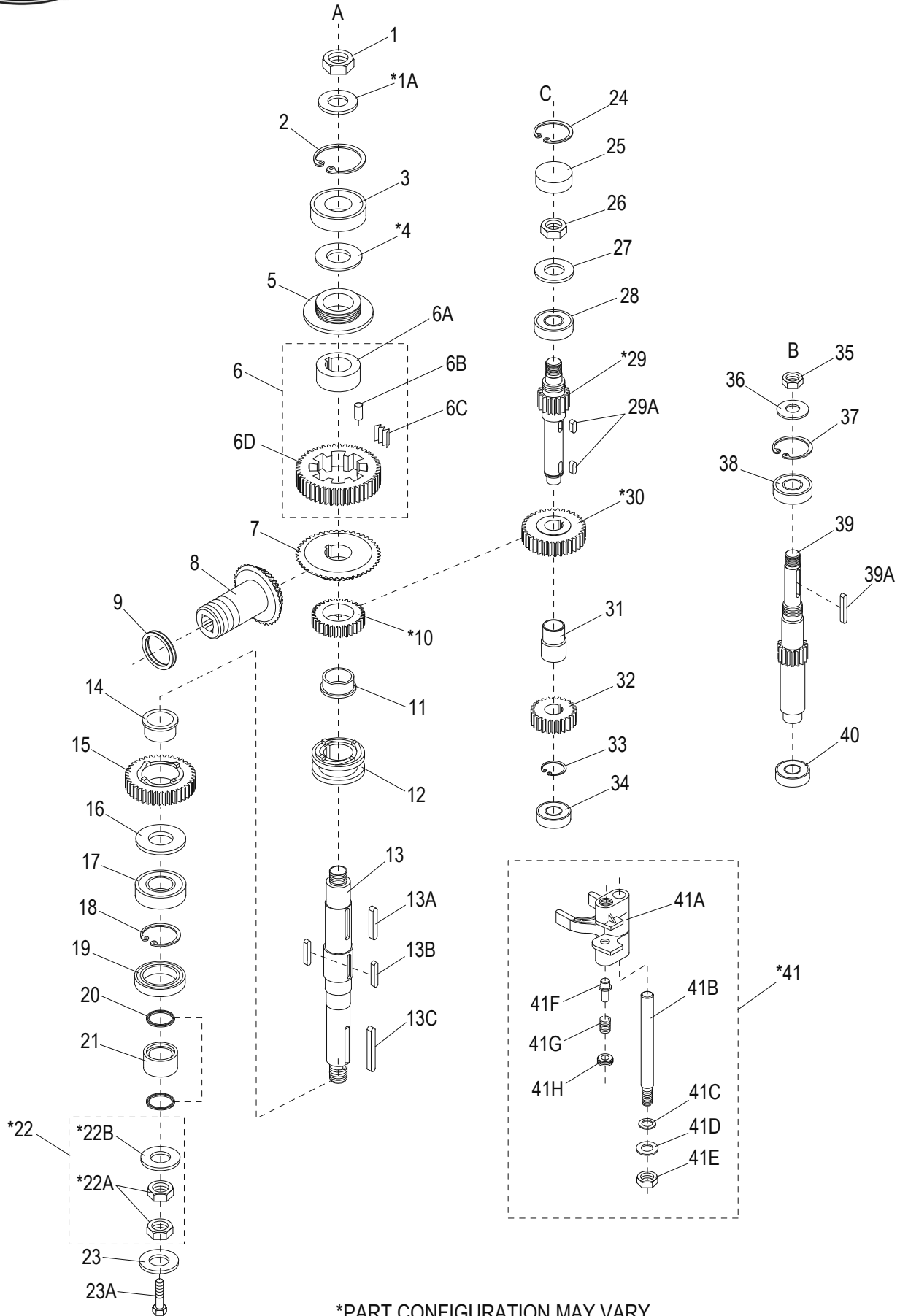

\*PART CONFIGURATION MAY VARY.



## SPC30P Gearbox Components

Item	Part Number	Description	Qty	Serial Number
1	X30111	Thin Hex Nut M20-1.5, OD-29, HT-10mm, Zn	1	
1A	X30111A	Flat Washer M20, ID-21, OD-37, TH-3mm, SS	Part Config. May Vary	1
2	X30112	Retaining Ring STW-52	1	
3	X30024	Ball Bearing	1	
4		Shim	Part Config. May Vary	1
5	X30113	Lead-In Oil Pad	1	
6	X30114-117	Slow Speed Gear Assembly	(Incl. items 6A-6D)	1
6A		Bushing	1	
6B		Roller Pin	1	
6C		Slice Spring	1	
6D		Gear, Slow Speed (52T)	1	
7	X30118	Gear, Bevel (52T)	1	
8	X30014	Level Drive Gear (35T)	1	
9	X30018-1	Thrust Washer ID-35mm, OD-55mm, TH-1mm	1	
10		Gear, Clutch (36T) Old Style	Replace With *	1
10	X30120-2	Gear, Clutch (35T) New Style	*, **	1
11	X30119	Bushing, Clutch	1	
12	X30133	Sleeve, Clutch	1	
13	X30130	Drive Shaft	1	
13A	X30121	Key H-8xW-8xL-40mm Round Ends	1	
13B	X30132	Key H-8xW-10xL-40mm Round Ends	1	
13C	X30131	Key H-10xW-10xL-55mm Round Ends	1	
14	X30119	Bushing, Clutch	1	
15	X30122	Gear, Clutch (45T)	1	
16	X30124	Heel	1	
17	X80F10	Ball Bearing	1	
18	X30126	C-Ring Retaining Ring STW-72	1	
19	X30128	Oil Seal	1	
20	X30221	O-Ring 36x30x3mm	2	
21	X30127	Guard, Oil Bushing	1	
22	X30129C	Washer M20 Flat & Stop Nut	Part Config. May Vary	1
22A	X30111	Thin Hex Nut M20-1.5, OD-29, HT-10mm, Zn	Part Config. May Vary	2
22B	X30111A	Flat Washer M20, ID-21, OD-37, TH-3mm, SS	Part Config. May Vary	1
23	X30129B	Washer M8x25x1.8 Flat	Part Config. May Vary	1
23A	X30129A	Screw M8x12mm Hex Head	Part Config. May Vary	1
24	X25106	Int. Retaining Ring ID-2, G-2.122, OD-2.210, TH-0.062" B.O.	1	
25		Cap, Shaft	1	
26	X30147	Thin Hex Nut M16-1.5, OD-24, HT-8, Zn	1	
27		Washer M16	1	
28	X10012	Ball Bearing	1	
29	X30150-1	Transmission Shaft (13T) Old Style, Keyed	Part Config. May Vary	1
29	X30150-2	Transmission Shaft (13T) New Style, Splined	1	
29A	X30149	Key, Round Ends H-7xW-7xL-18mm	2	
30		Gear (29T) Old Style	Replace With *	1
30	X30148-2	Gear (30T) New Style	*, **	1
31	X30144	Bushing, Spacer	1	
32	X30143-1	Gear (20T) Old Style, Keyed	1	
32	X30143-2	Gear (20T) New Style, Splined	1	
33	X30141	Retaining Ring STW-24	1	
34	X30140	Ball Bearing	1	
35	X30147	Thin Hex Nut M16-1.5, OD-24, HT-8, Zn	1	
36		Washer, Flat M16	1	
37	X30146	Int. Retaining Ring ID-1-3/4, Groove-1.858, OD-1.942, TH-0.062"	1	



## SPC30P Gearbox Components

---

Item	Part Number	Description	Qty	Serial Number
38	X10012	Ball Bearing	1	
39	X30145	Shaft, Master (15T) *	1	Replace with **
39A	X30081	Shaft 5x5x30mm Key	1	
40	X30140	Ball Bearing	1	Part Config. May Vary
41	X30134-139	Yoke Shifter Assembly	1	(Incl. items 41A-41H)
41A		Washer, Flat M16	1	
41B		Guide, Rod Shifter	1	
41C	X01372	Lock Washer M12, ID-12.7, OD-21, TH-2.5mm, SS	2	
41D	X01370	Washer M12 Flat	2	
41E	X30215	Hex Nut M12-1.75, OD-19mm, HT-10mm, Zn	2	
41F		Plunger, Yoke Shifter	1	
41G		Spring, Yoke Shifter	1	
41H		Spring, Retainer	1	





*INTENTIONALLY LEFT BLANK PAGE*



# SPC30P Motor Components

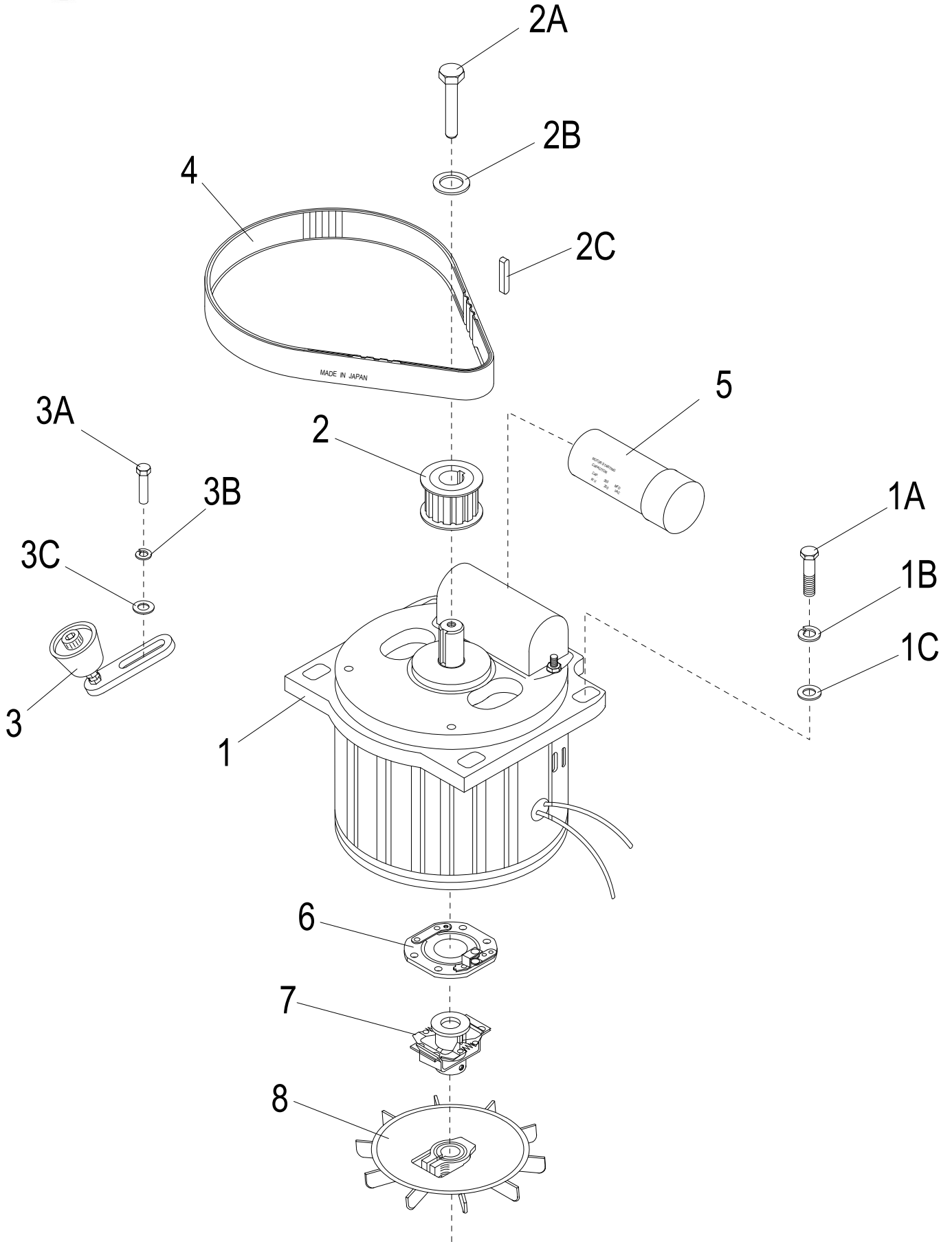



## SPC30P Motor Components

---

Item	Part Number	Description	Qty	Serial Number
1	X30068PC	Motor, 1.5HP 220/60/1 - Motor Brake	1	
1A	X30069	Screw M8x30mm Hex Hd	4	
2	X30071	Wheel, Motor Cog (18T) 60HZ	1	
2	X00734	Wheel, Motor Cog (20T) 50HZ	1	
2A	X30075	Ext. Hex Hd Screw M8-1.25x20mm, Zn	1	
2B	X30074	Flat Washer M8, ID-8, OD-24, TH-2mm, Zn	2	
2C	X40073	Key H-5xW-5xL-20mm Round Ends	1	
3	X30158	Belt Tensioner	1	
3A		Screw M8x24mm Hex Hd	2	
3B		Washer M8 Split Lock	2	
3C		Washer M8 Flat	2	
4	X30072-1	Cogged Belt (S8M-800)	1	
4	X40072-1	Cogged Belt (S8M-880)	1	
5	X30070-1P	Capacitor, Start 500Mf	1	
6	X10051	Switch, Platinum	1	
7	X25059	Clutch	1	
8	X30061	Cooling Fan	1	
-	300		0	



# SPC30P Motor Brake Components

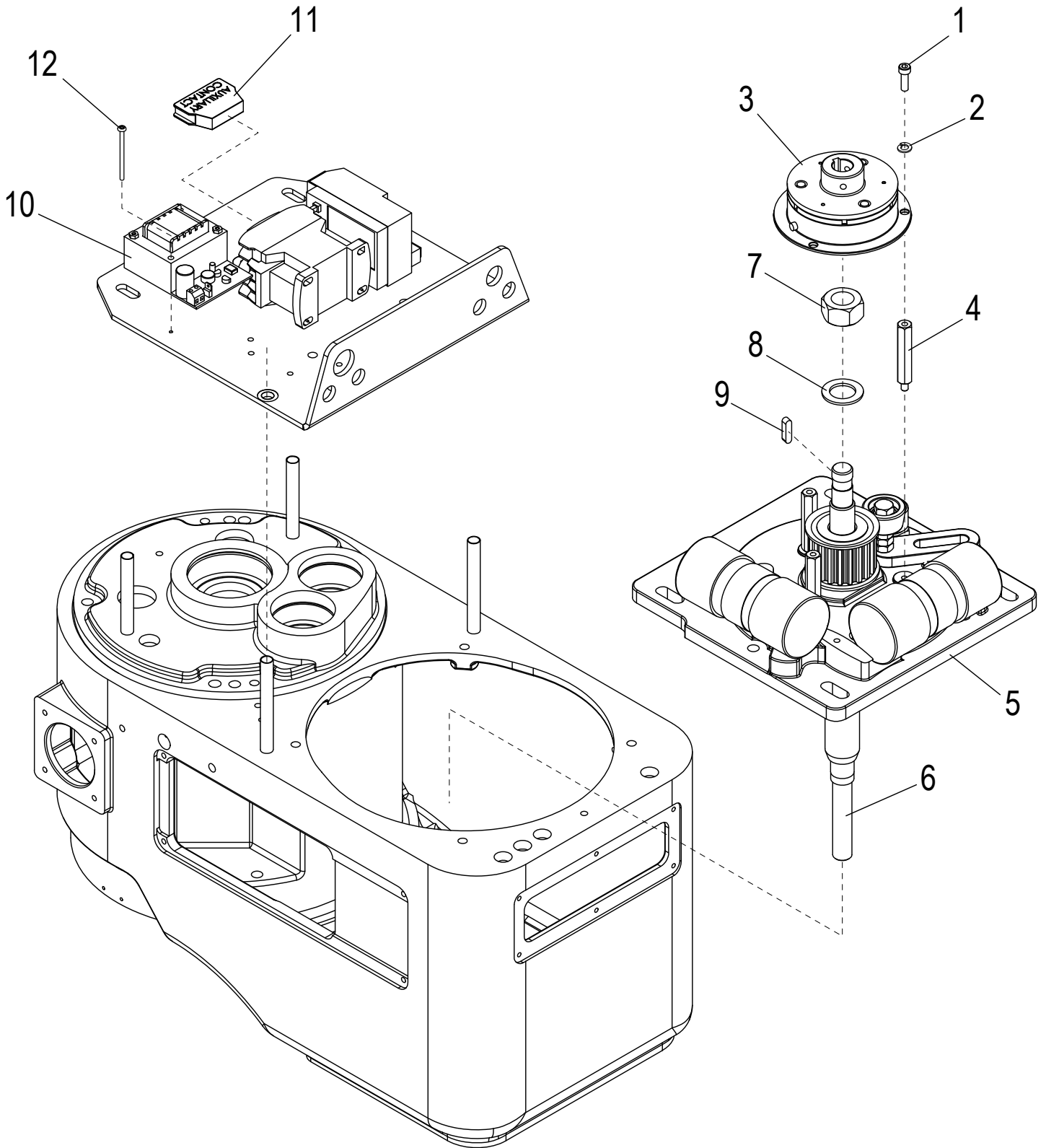



## SPC30P Motor Brake Components

---

Item	Part Number	Description	Qty	Serial Number
1		Screw M5x12mm Socket Hd	4	
2		Washer M8 Split Lock	1	
3	X30501	Motor Brake, Magnetic	1	
4	X30502	Hex Standoff	3	
5		Top Cover, Motor	1	
6		Motor Shaft	1	
7		Nut M18 Hex	1	
8		Washer M18 Flat	1	
9		Shaft Key 5x5x17mm	1	
10	X20512-1	Electronic Board	1	
11	X25503	Auxiliary Contact Block	1	
12		Screw M3x34mm Hex Hd	2	

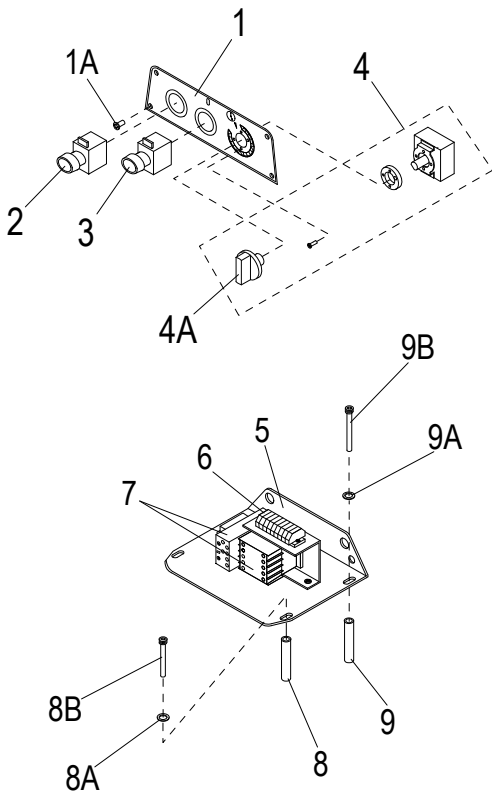

Manual Timer

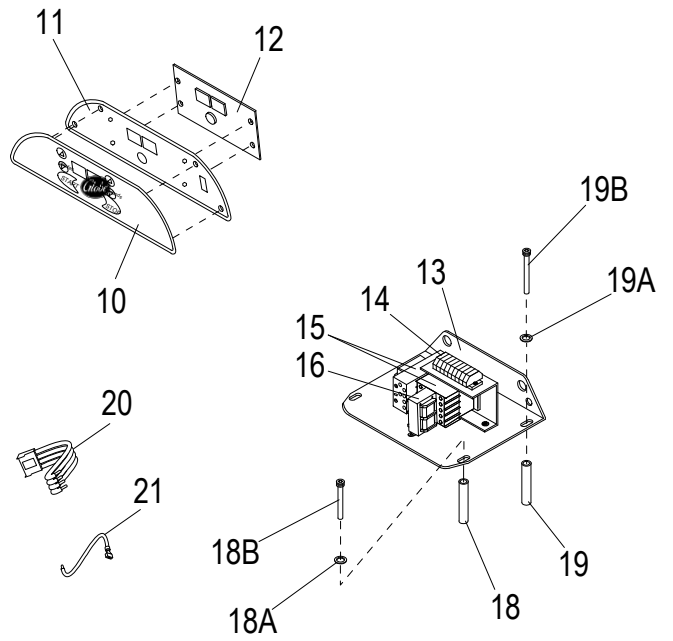

Digital Timer



## SPC30P Manual and Digital Timer

Item	Part Number	Description	Qty	Serial Number
1	X30005	Control Panel	1	
1A	X30204	Screw M4x10mm Truss Hd	6	
1B	X30009	Gasket, Control Panel	1	
2	X10050	Emergency Stop Button	1	
3	X30007	Start Button	1	
3A	X30007-1	Boot, Start/Stop Switch Button	2	
3B	X30007-1B	Light Bulb, Start Button	1	
4	X10137	Timer Assembly With Knob	1	
4A	X10137-1	Timer Knob	1	
5	X30013	Plate, Electronics Mounting	1	
6		Connecting Block Set	1	
6	X10029-2G	Connecting Block, Gray (2C)	7	
6	X10029-4R	Connecting Block, Orange (4R)	1	
6	X30012-EC	Connecting Block End Cap	1	
7	X30154P	Overload Relay Kit, 220/60/1	1	
8	X30153	Tube, Support	2	
8A		Washer M8 Flat	2	
8B	X30086	Socket Hd Cap Screw M8-1.25x100mm, B.O.	2	
9	X30085	Tube M8x108mm Support	2	
9A		Washer M8 Flat	2	
9B	X30010	Socket Hd Cap Screw M8-1.25x90mm B.O.	2	
10	X00566	Switch, Membrane	1	
11	X01337	Aluminum Panel	1	
12	X00568	Control Board	1	
13	X30013	Plate, Electronics Mounting	1	
14		Connecting Block Set	1	
14	X10029-2G	Connecting Block, Gray (2C)	7	
14	X10029-4R	Connecting Block, Orange (4R)	1	
14	X10029-EC	Connecting Block End Cap	1	
15	X30154P	Overload Relay Kit, 220/60/1	1	
16	X00569	Control Transformer Assembly	1	
17	X00570	Control Transformer Fuse	1	
18	X30153	Tube, Support	2	
18A		Washer M8 Flat	2	
18B	X30086	Socket Hd Cap Screw M8-1.25x100mm, B.O.	2	
19	X30085	Tube M8x108mm Support	2	
19A		Washer M8 Flat	2	
19B	X30010	Socket Hd Cap Screw M8-1.25x90mm B.O.	2	
20	X00675	4 Wire Harness With Connector	1	
21	X00676	Single Wire With Quick Connect	2	



# SPC30P Wiring Diagram, 220V Single Phase

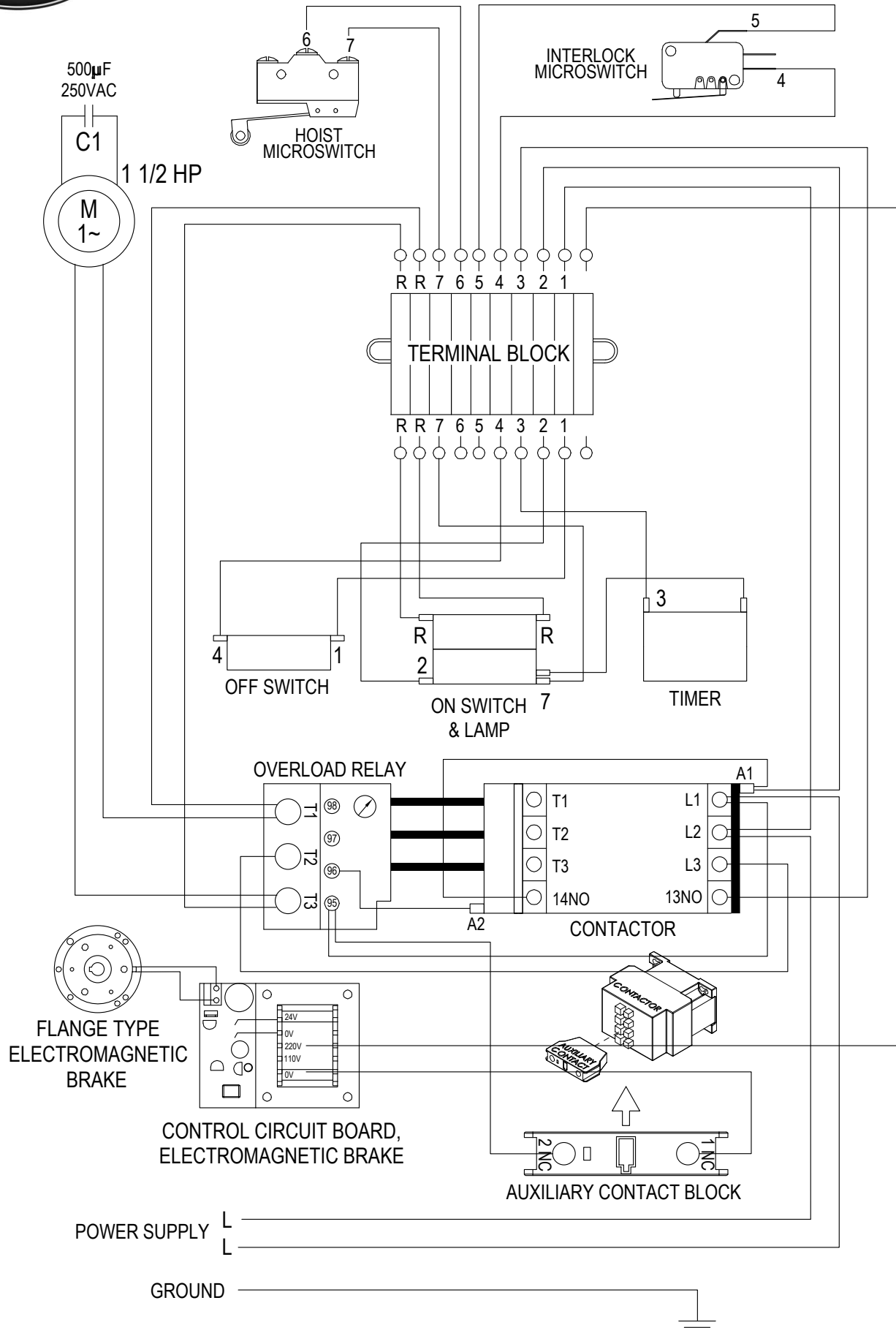





# SPC30P Wiring Diagram, Single Phase, Digital Timer

