

Parts Catalog



SPC40

Mixer

Model: SPC40

10/02/2019 Rev B

IMPORTANT!

TO EXPEDITE SHIPMENT OF PARTS, ALWAYS SPECIFY MODEL, REV,
PART NUMBER, AND SERIAL NUMBER OF UNIT.

GLOBE FOOD EQUIPMENT COMPANY

2215 East River Road
Dayton, Ohio 45439

Parts Department

Toll Free 1-800-745-6238 · Fax (937) 290-0585

E-Mail: info@globefoodequip.com

Website: www.globefoodequip.com

Not for resale

Table of Contents

Description	Page
SPC40 Base Components	4
SPC40 Head Components	8
SPC40 Hub Assembly Components	12
SPC40 Planetary Components	14
SPC40 Gearbox Components	16
SPC40 Motor Components	20
SPC40 Motor Brake Components	22
SPC40 Manual and Digital Timer	24
SPC40 Wiring Diagram, 220V Single Phase	26
SPC40 Wiring Diagram, 208V Three Phase	27
SPC40 Wiring Diagram, 220V Single Phase	28



SPC40 Base Components

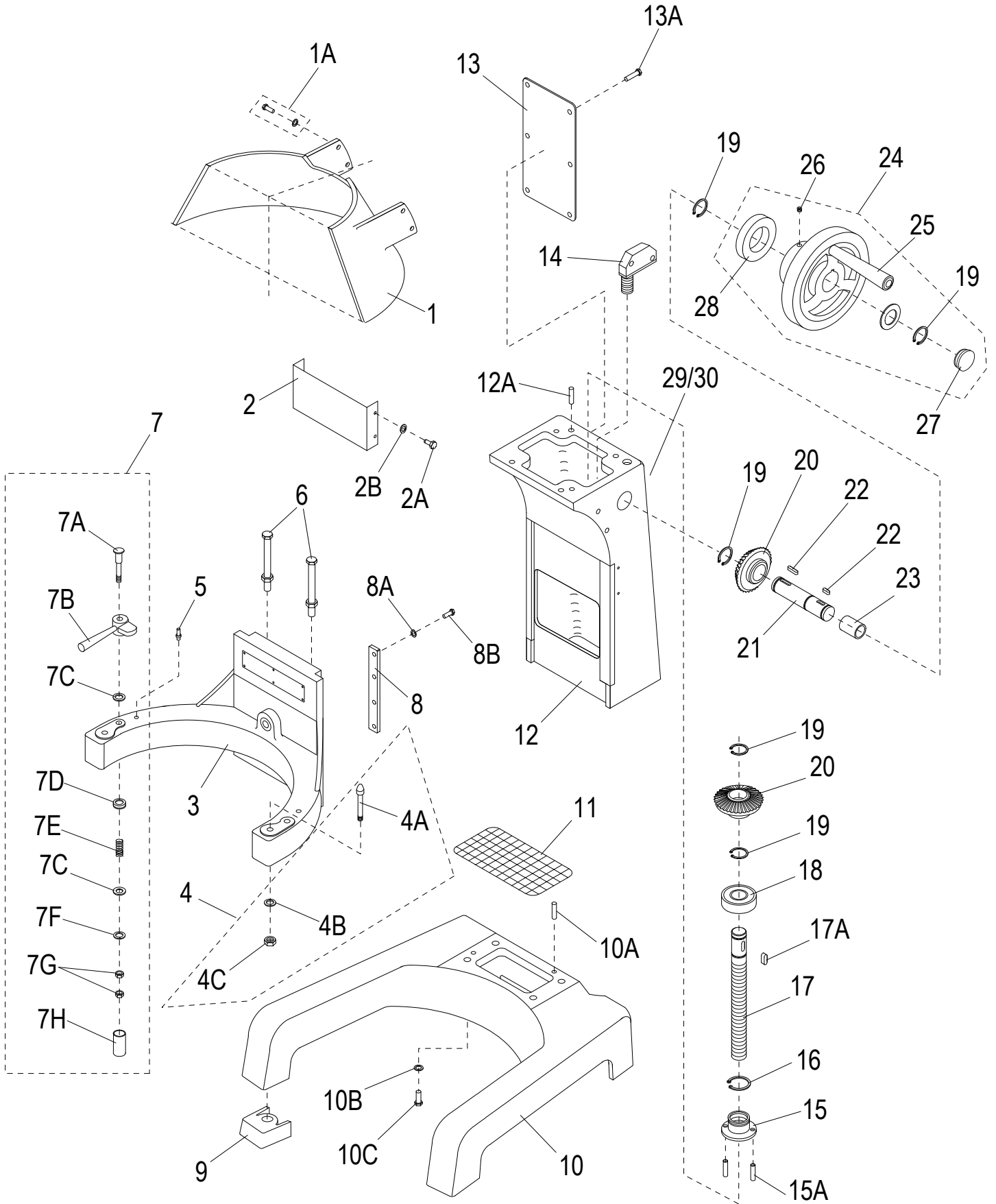



SPC40 Base Components

Item	Part Number	Description	Qty	Serial Number
1	X40036	Guard, Rear	1	
1A	X30101	Hex Screw M8x20mm & Flat Washer	4	
2	X40102	Mixer Column Cover	1	
2A	X40056	Truss Hd Screw PHH M6-1.0x10mm, SS-18	3	
2B		Washer M6 Flat	3	
3	X40034	Bowl Cradle	1	
4	X40109	Dowel Screw Assembly	2	
4A		Dowel Screw	2	
4B	X01372	Lock Washer M12, ID-12.7, OD-21, TH-2.5mm, SS	2	
4C	X40110	Cap Nut, M12-1.75, OD-19mm, HT-22mm, Class 10, Zn	2	
5		Bowl Clamp Stop Pin	2	
6	X40106	Screw M10x54mm Hex Hd/Nut (Touch Shaft)	1	
7	X30033	Bowl Clamp Assembly (Set/2)	1	
7A	X30108	Bowl Clamp Hardware Kit	2	
7B	X30033-2	Bowl Clamp (Set/2, New Style)	1	
7C		Washer M12 Flat	4	
7D		Hardware Cap Retainer	2	
7E		Spring	2	
7F		Washer M10 Split Lock	2	
7G		Nut M12 Acorn	4	
7H		Hardware Cap	2	
8	X40035	Cradle Slide Guides	2	
8A		Washer M8 Flat	8	
8B	X30197	Ext. Hex Hd Screw M8-1.25x25mm, SS	8	
9	X40162-163	Front/Rear Rubber Feet (Set)	1	
10	X40038-DG	Mixer Base	1	
10A	X40040	Dowel Pin Ø8x16mm Column Locator	2	
10B		Washer M12 Flat	4	
10C		Screw M12x40mm Hex Hd	4	
11	X40037	Base Screen	1	
12	X40042	Mixer Column	1	
12A	X30178	Dowel Pin Ø8x16mm Head Locator	2	
13	X40055	Plate, Rear Cover	1	
13A	X40056	Truss Hd Screw PHH M6-1.0x10mm, SS-18	6	
14	X30051-1	Microswitch, Bowl Lift	1	
15	X30104	Screw Sleeve	1	
15A	X30105	Roll Pin Ø4x30mm	1	
16	X25145	Retaining STW-35 Ring	1	
17	X40041	Bowl Lift Screw	1	
17A	X20123	Key, Round Ends H-5xW-5xL-18mm	1	
18	X30043	Ball Bearing	1	
19		Ext. Retaining Ring, OD-25, Groove-23.9, Ring ID-23.2, TH-1.2mm, B.O.	5	
20	X30045	Oblique Gear (30T)	2	
21	X40047	Shaft, Hand Wheel	1	
22	X40073	Key H-5xW-5xL-20mm Round Ends	2	
23	X40050	Oilless Bearing	1	
24	X40053	Hand Wheel Crank With Handle, Plastic	1	
24	X40053M	Hand Wheel Crank With Handle, Metal	1	
25	X30053-1	Hand Wheel Crank Handle	1	
26		Set Screw M10x8mm Cup Pt. (Metal Wheel Only)	1	
27		Hand Wheel Cap	1	
28		Spacer (50m mod x 25.3mm Id x 10.2mm)	1	
29	X91014	Label, Hazardous Voltage (Not Shown)	1	



SPC40 Base Components

Item	Part Number	Description	Qty	Serial Number
30	X91011	Label, Caution - 3 Phase (Not Shown)	1	



INTENTIONALLY LEFT BLANK PAGE



SPC40 Head Components

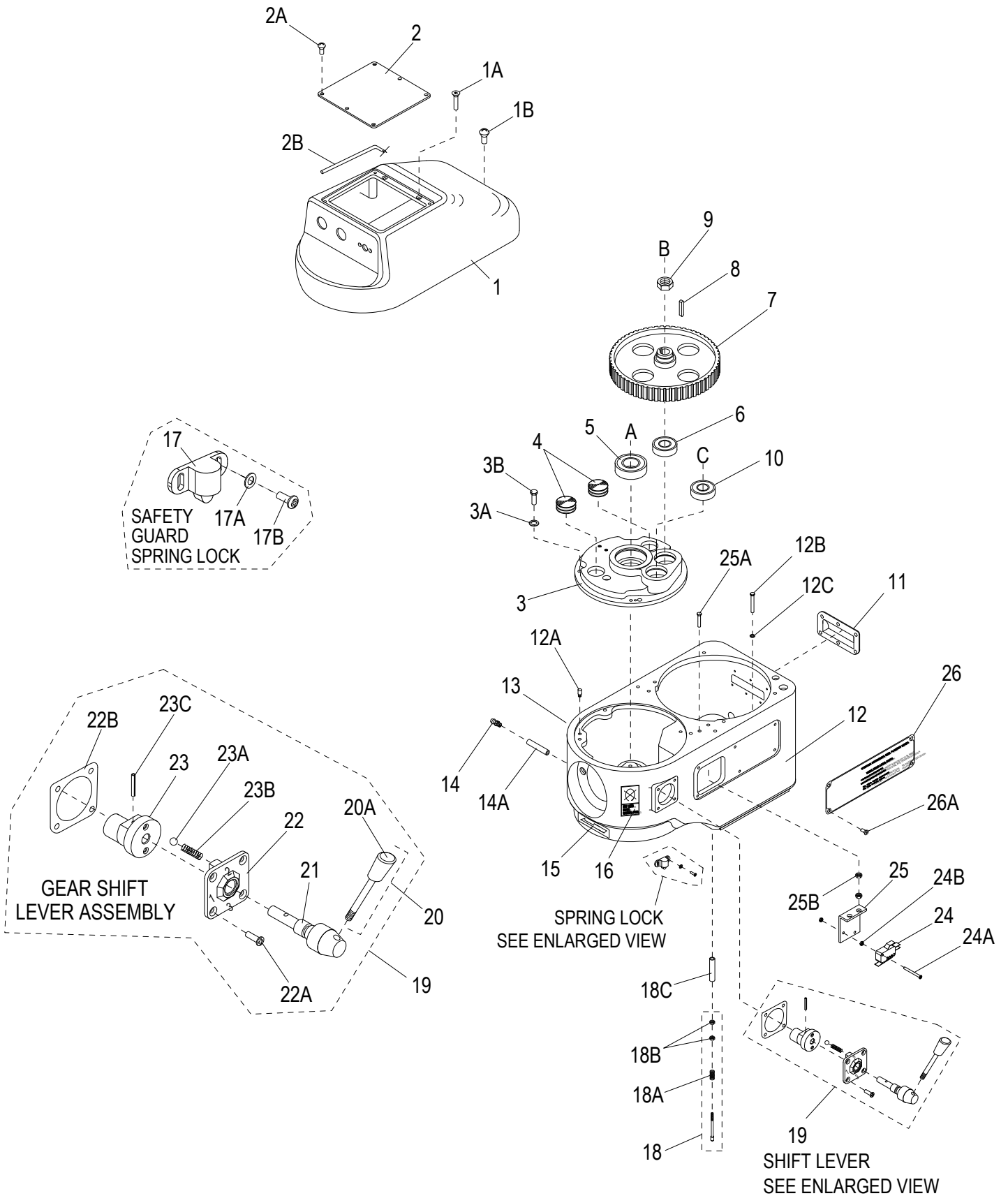



SPC40 Head Components

Item	Part Number	Description	Qty	Serial Number
1	X40004-1-DG	Cover, Transmission	1	
1A	X30207	Flat Hd Screw-Socket M8-1.25x108mm, B.O.	2	
1B	X30220	Flat Hd Screw-Socket M6-1.0x90mm, B.O.	1	
2	X40002	Cover, Switch Box	1	
2A	X40056	Truss Hd Screw PHH M6-1.0x10mm, SS-18	6	
2B	X40003	Gasket, Switch Box	1	
3	X40077	Cover, Gear Housing	1	
3A	X30198	Lock Washer M8, ID-8.5mm, OD-12.7mm, TH-2mm	4	
3B	X30197	Ext. Hex Hd Screw M8-1.25x25mm, SS	4	
4	X10073	Oil Plug	2	
5	X30024	Ball Bearing	1	
6	X10012	Ball Bearing	1	
7	X60080	Wheel, Main Cog (97T)	1	
8	X40081	Key H-5xW-5xL-12mm Round Ends	1	
9	X40082	Thin Hex Nut M18-1.5, OD-27, Thick-9mm, CLASS 04, Zn	1	
10	X10012	Ball Bearing	1	
11	X30076	Plate, Ventilation	1	
12	X40087	Transmission Case, Fixed Bowl Guard (1 Phase)	1	->7410525
12	X40087-1	Transmission Case, Removable Bowl Guard (1 Phase)	1	7410524 ->
12	X40087	Transmission Case, Fixed Bowl Guard (3 Phase)	1	->7450536
12	X40087-1	Transmission Case, Removable Bowl Guard (3 Phase)	1	7450535 ->
12A		Pin, Locating	2	
13	X91009	Label, Lubricate	1	
14	X10900	Grease Fitting	1	
14A	X10217	Grease Tube	1	
15	X91012	Label, Arrow	1	
16	X91010	Label, Stop To Chg Gears	1	
17	X10134	Safety Guard Spring Lock	1	
17A		Washer M3 Flat	2	
17B	X10134B	Round Hd Screw-PHH M3-0.5x8mm, SS-18	2	
18	X40096	Touch Shaft Assy, Brass	1	
18	X30096N	Touch Shaft, Nylon	1	
18A	X30095	Spring	1	
18B	X30186	Hex Nut M5-0.8 OD-8, TH-4mm, Zinc	2	
18C	X40187	Tube	1	
19	X40057-60	Gear Shift Lever Assembly	1	
20	X40057	Gear Shift Lever With Knob	1	
20A	X30057-1	Knob, Gear Shift	1	
21		Shaft	1	
22		Cover	1	
22A	X30179	Flat Hd Screw-Socket M8-1.0x16mmHd, Zn	4	
22B	X30059-1	Gasket	1	
23		Shaft Bias	1	
23A		Roller	2	
23B		Spring	2	
23C		Roll Pin Ø5x28mm	1	
24	X10057-1	Microswitch, Interlock	1	
24A	854-2	Screw, Magnet Mounting	2	
24B	854-3	Nut, Magnet Mounting	4	
25	X30062	Bracket, Microswitch	1	
25A		Screw M6x20mm Hex Hd	2	
25B		Nut M6 Hex	4	
26	X30066	Plate, Warning	1	



SPC40 Head Components

Item	Part Number	Description	Qty	Serial Number
26A	X30065	Truss Hd Screw-Phillips M5-0.8x10mm, SS	4	



INTENTIONALLY LEFT BLANK PAGE



SPC40 Hub Assembly Components

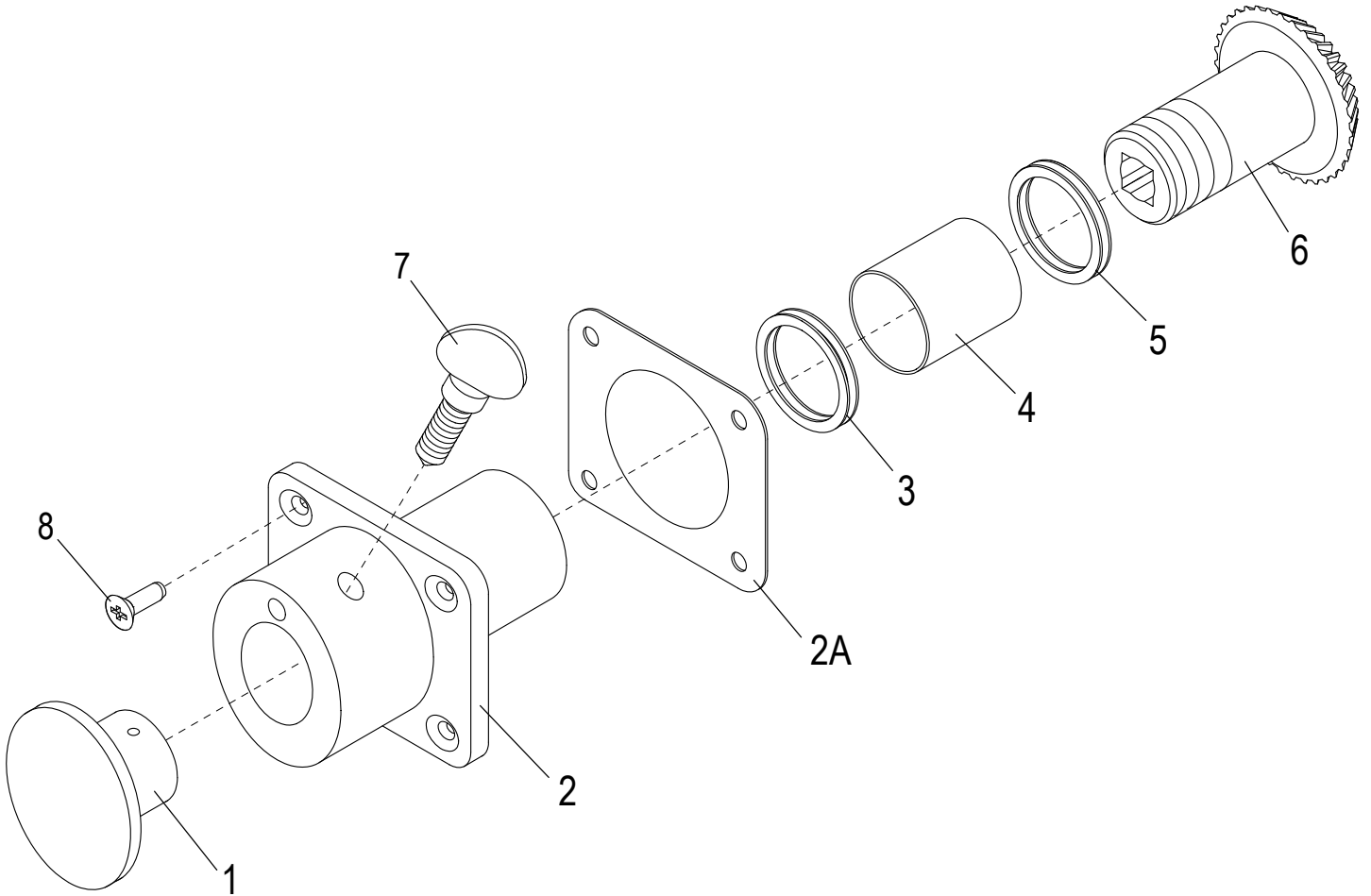



SPC40 Hub Assembly Components

Item	Part Number	Description	Qty	Serial Number
1	X10007	Attachment Hole Plug	1	
2	X40017-DG	Attachment Hub	1	
2A		Gasket	1	
3	X10089	Oil 45x35x8mm Seal	1	
4	X10075	Bearing	1	
5	X30018-1	Thrust Washer ID-35mm, OD-55mm, TH-1mm	2	
6	X40014	Level Drive Gear (35T)	1	
7	X10005	Thumb Screw 1/2-13x3/4"	1	
8	X80B52	Socket Hd Cap Screw M6-1.0x20mm, B.O.	4	



SPC40 Planetary Components

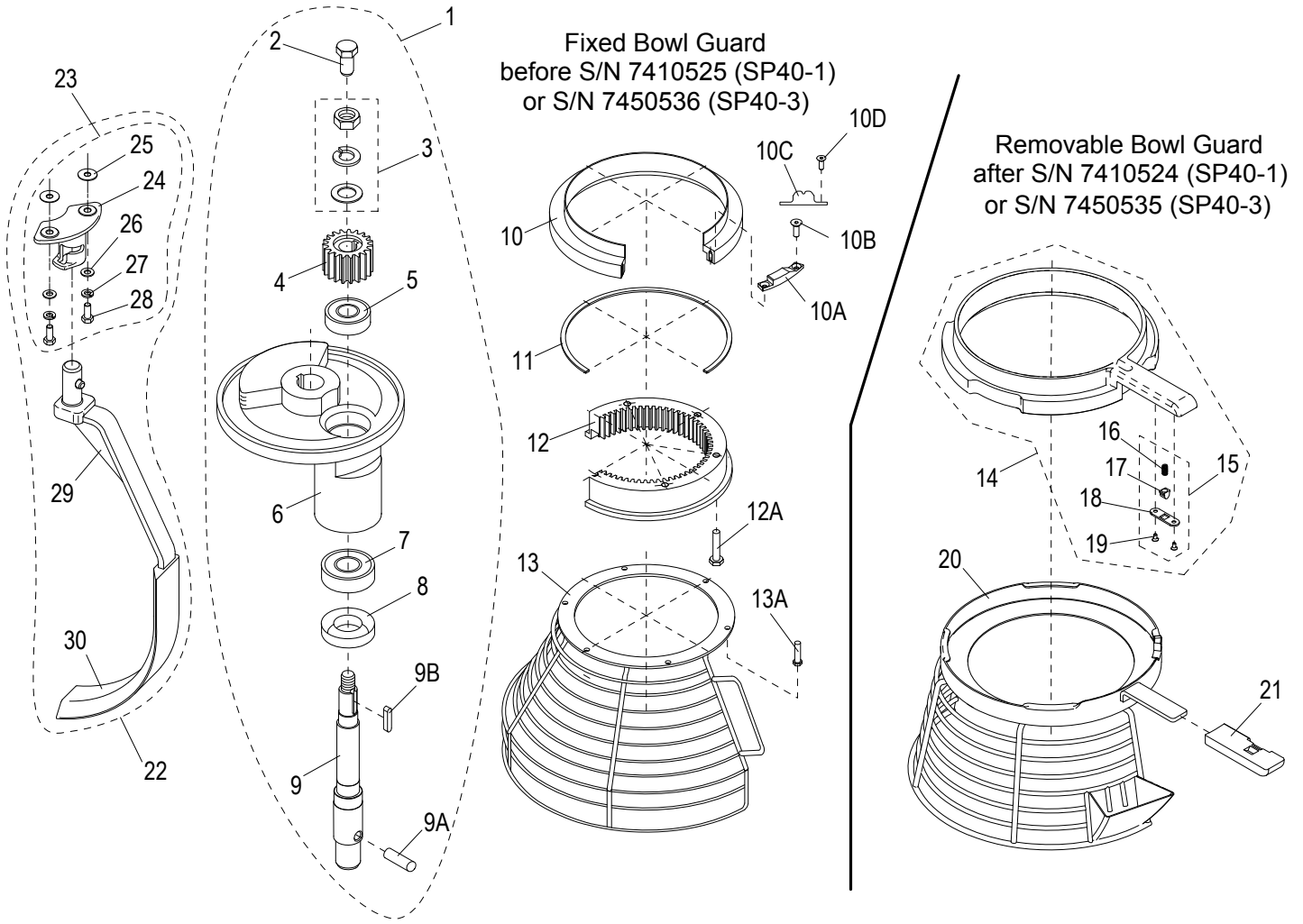



SPC40 Planetary Components

Item	Part Number	Description	Qty	Serial Number
1	X40019-28	Complete Planetary Assembly	1	
2	X40019	Screw M10x24mm (Old Style Shaft)	1	
3	X30020	Nut M14 Stop & Washers	1	
4	X40021	Pinion, Beater (21T)	1	
5	X10102	Ball Bearing	1	
6	X40023-DG	Planetary Shaft Holder	1	
7	X30024	Ball Bearing	1	
8	X40025	Oil Seal	1	
9	X40027	Planetary Shaft, External Thread (New Style)	1	
9		Planetary Shaft, Internal Thread (Old Style)	1	
9A	X30028	Dowel Pin M12x17mm	1	
9B	X40026	Key H-7xH-7xL23mm Round Ends	1	
10	X40090	Slide Sheath, Metal	1 Phase or 3 Phase	1 ->7410525 or 7450536
10A	X10041	Touch Mass	1 Phase or 3 Phase	2 ->7410525 or 7450536
10B	X10042	Flat Hd Screw-Phillips M4-0.7x10mm, Zn	1 Phase or 3 Phase	2 ->7450536 or 7450536
10C	X10135	Safety Guard Spring Lock Fixture	1 Phase or 3 Phase	1 ->7410525 or 7450536
10D		Screw M4x10mm Round Hd	1 Phase or 3 Phase	2 ->7410525 or 7450536
11	X40091	Gasket	1 Phase or 3 Phase	1 ->7410525 or 7450536
12	X40092	Ring Gear (67T)	1 Phase or 3 Phase	1 ->7410525 or 7450536
12A	X30099	Socket Hd Cap Screw M8-1.25x35mm, B. O.	1 Phase or 3 Phase	6 ->7410525 or 7450536
13	X40093-94	Front Interlocking Guard Assy	1 Phase or 3 Phase	1 ->7410525 or 7450536
13A	X10083	Ext. Hex Hd Screw M5-0.8x10mm, SS	1 Phase or 3 Phase	6 ->7410525 or 7450536
14	X400S2	Plastic Slide Sheath, Removable Safety Guard	1 Phase or 3 Phase	1 7410524 or 7450535 ->
15	X200S3	Spring Plunger Hardware Kit	1 Phase or 3 Phase	1 7410524 or 7450535 ->
16		Spring	1 Phase or 3 Phase	1 7410524 or 7450535 ->
17		Plunger	1 Phase or 3 Phase	1 7410524 or 7450535 ->
18		Plate, Plunger Retention	1 Phase or 3 Phase	1 7410524 or 7450535 ->
19		Screw M3x8mm Flat Hd	1 Phase or 3 Phase	2 7410524 or 7450535 ->
20	X400S1	Bowl Guard Assembly, Stainless Steel	1 Phase or 3 Phase	1 7410524 or 7450535 ->
21	X30504	Handle, Plastic - Removable Safety Guard	1 Phase or 3 Phase	1 7410524 or 7450535 ->
22	XXSCRP-40	Bowl Scraper Assembly	1 Phase or 3 Phase	1 7410619 or 7450580 ->
23	X02000	Scraper Mounting Kit	1 Phase or 3 Phase	1 7410619 or 7450580 ->
24		Washer	1 Phase or 3 Phase	2 7410619 or 7450580 ->
25		Scraper Mounting Hub	1 Phase or 3 Phase	1 7410619 or 7450580 ->
26		Washer M8 Flat	1 Phase or 3 Phase	2 7410619 or 7450580 ->
27		Washer M8 Split Lock	1 Phase or 3 Phase	2 7410619 or 7450580 ->
28		Screw M8x25mm Hex Hd	1 Phase or 3 Phase	2 7410619 or 7450580 ->
29		Scraper Arm	1 Phase or 3 Phase	1 7410619 or 7450580 ->
30		Bowl Scraper	1 Phase or 3 Phase	1 7410619 or 7450580 ->



SPC40 Gearbox Components

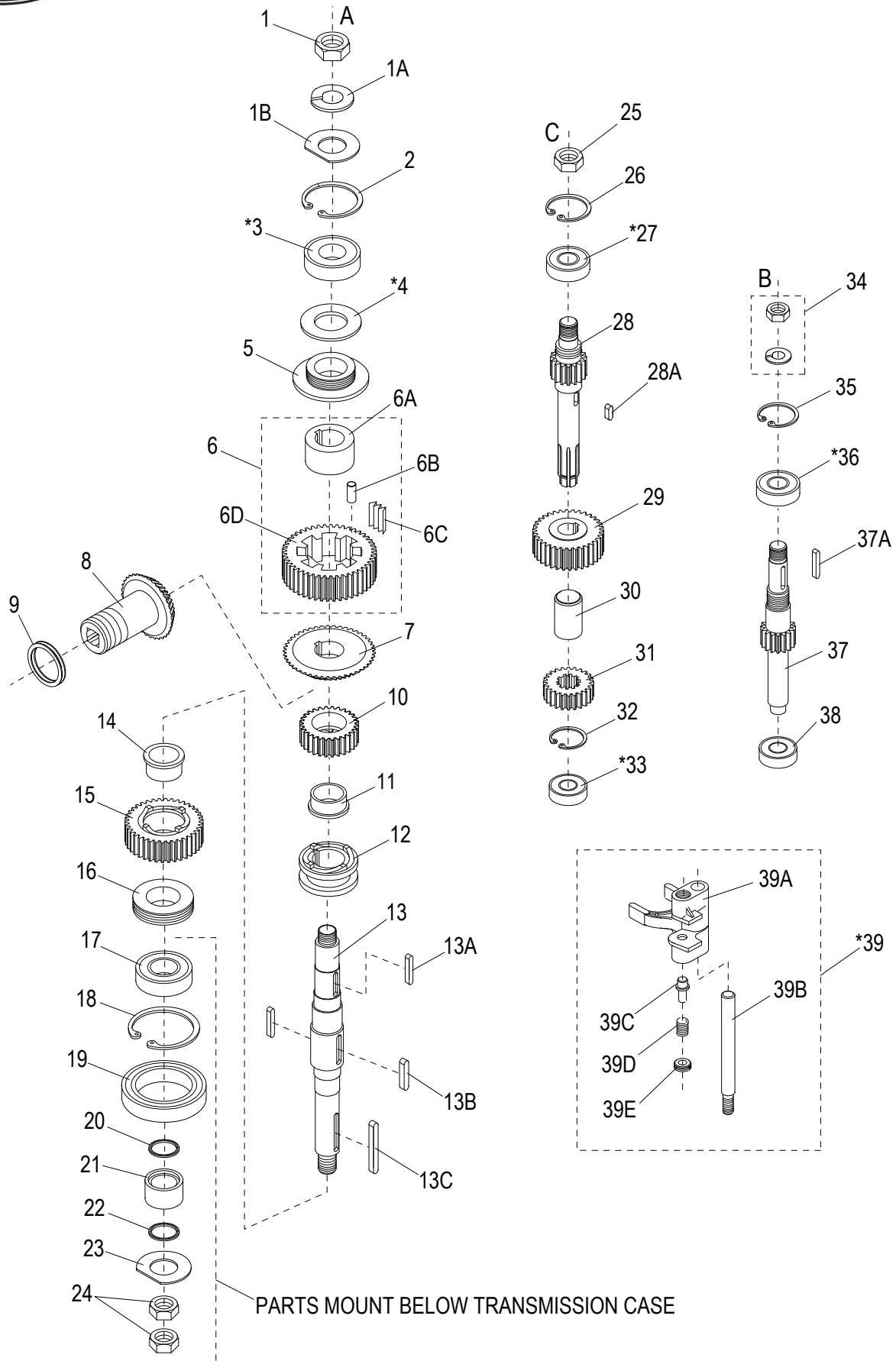

*PART CONFIGURATION MAY VARY.



SPC40 Gearbox Components

Item	Part Number	Description	Qty	Serial Number
1	X40111	Nut M24 Jam	1	
1A	X40111A	Lock Washer M24, ID-25.5, OD-40, TH-5mm, Plain	1	
1B		Washer M24 Flat D Shape	1	
2	X30112	Retaining Ring STW-52	1	
3	X30024	Ball Bearing	1 Phase or 3 Phase	1 7410232 or 7450266 ->
4		Shim	1 Phase or 3 Phase	0 7410232 or 7450266 ->
5	X40113	Lead-In Oil Pad	1	
6	X40114-117	Slow Speed Gear Assembly	1	
6A		Bushing	1	
6B		Dowel Ø8x16mm Pin	1	
6C		Slice Spring	1	
6D		Gear, Slow Speed (52T)	1	
7	X40118	Gear, Bevel (52T)	1	
8	X40014	Level Drive Gear (35T)	1	
9	X30018-1	Thrust Washer ID-35mm, OD-55mm, TH-1mm	1	
10	X40120	Gear, Clutch (36T) Old Style	1	
10		Gear, Clutch (34T) New Style	1	
10	X40222	Gear, Clutch (34T) New Style	1 Phase or 3 Phase	1 7410232 or 7450266 ->
11	X40119	Bushing, Clutch	1	
12	X40133	Sleeve, Clutch	1	
13	X40130	Drive Shaft	1	
13A	X40121	Key H-8xW-8xL-45mm Round Ends	1	
13B	X40132	Shaft Key 8x8x40mm RR	2	
13C	X30131	Key H-10xW-10xL-55mm Round Ends	1	
14	X40119	Bushing, Clutch	1	
15	X40122	Gear, Clutch (45T)	1	
16	X30124	Heel	1	
17	X40125	Ball Bearing	1	
18	X40126	Ext. Retaining Ring ID-3, G-3.182, OD-3.325, TH-0.093" B.O.	1	
19	X40128	Oil Seal	1	
20	X30221	O-Ring 36x30x3mm	1	
21	X40127	Guard, Oil Bushing	1	
22	X30221	O-Ring 36x30x3mm	1	
23		Washer M20 Flat D Shape	1	
24	X30111	Thin Hex Nut M20-1.5, OD-29, HT-10mm, Zn	2	
25	X40152	Thin Hex Nut M18 OD-27, HT-9mm, Class 04, Zn	1	
26	X25106	Int. Retaining Ring ID-2, G-2.122, OD-2.210, TH-0.062" B.O.	1	
27	X10012	Ball Bearing	1 Phase or 3 Phase	1 7410232 or 7450266 ->
28	X40150-1	Transmission Shaft (13T) Old Style, Keyed	1	
28	X40150-2	Transmission Shaft (13T) New Style, Splined	1	
28A	X40149	Key H-8xW-8xL-24mm Round Ends	1	
29	X40148	Gear (29T) Old Style	1	
29	X40223	Gear (31T) New Style	1 Phase or 3 Phase	1 7410232 or 7450266 ->
30	X40144	Bushing, Spacer	1	
31	X40143-1	Gear (20T) Old Style, Keyed	1	
31	X40143-2	Gear (20T) New Style, Splined	1	
32	X40141	Retaining Ring STW-24	1	
33	X30140	Ball Bearing	1 Phase or 3 Phase	1 7410232 or 7450266 ->
34	X40082	Thin Hex Nut M18-1.5, OD-27, Thick-9mm, CLASS 04, Zn	1	
35	X30146	Int. Retaining Ring ID-1-3/4, Groove-1.858, OD-1.942, TH-0.062"	1	
36	X10012	Ball Bearing	1 Phase or 3 Phase	2 7410232 or 7450266 ->
37	X40145	Shaft, Master (15T)	1	
37	X40224	Shaft, Master (13T)	1 Phase or 3 Phase	1 7410232 or 7450266 ->



SPC40 Gearbox Components

Item	Part Number	Description	Qty	Serial Number
37A	X40081	Key H-5xW-5xL-12mm Round Ends	1	
38	X30140	Ball Bearing	1	
39	X40134-139	Yoke, Shifter Assembly	1	
39A		Yoke, Shifter	1	
39B		Guide, Rod Shifter	1	
39C		Plunger, Yoke Shifter	1	
39D		Spring, Yoke Shifter	1	
39E		Spring, Retainer	1	



INTENTIONALLY LEFT BLANK PAGE



SPC40 Motor Components

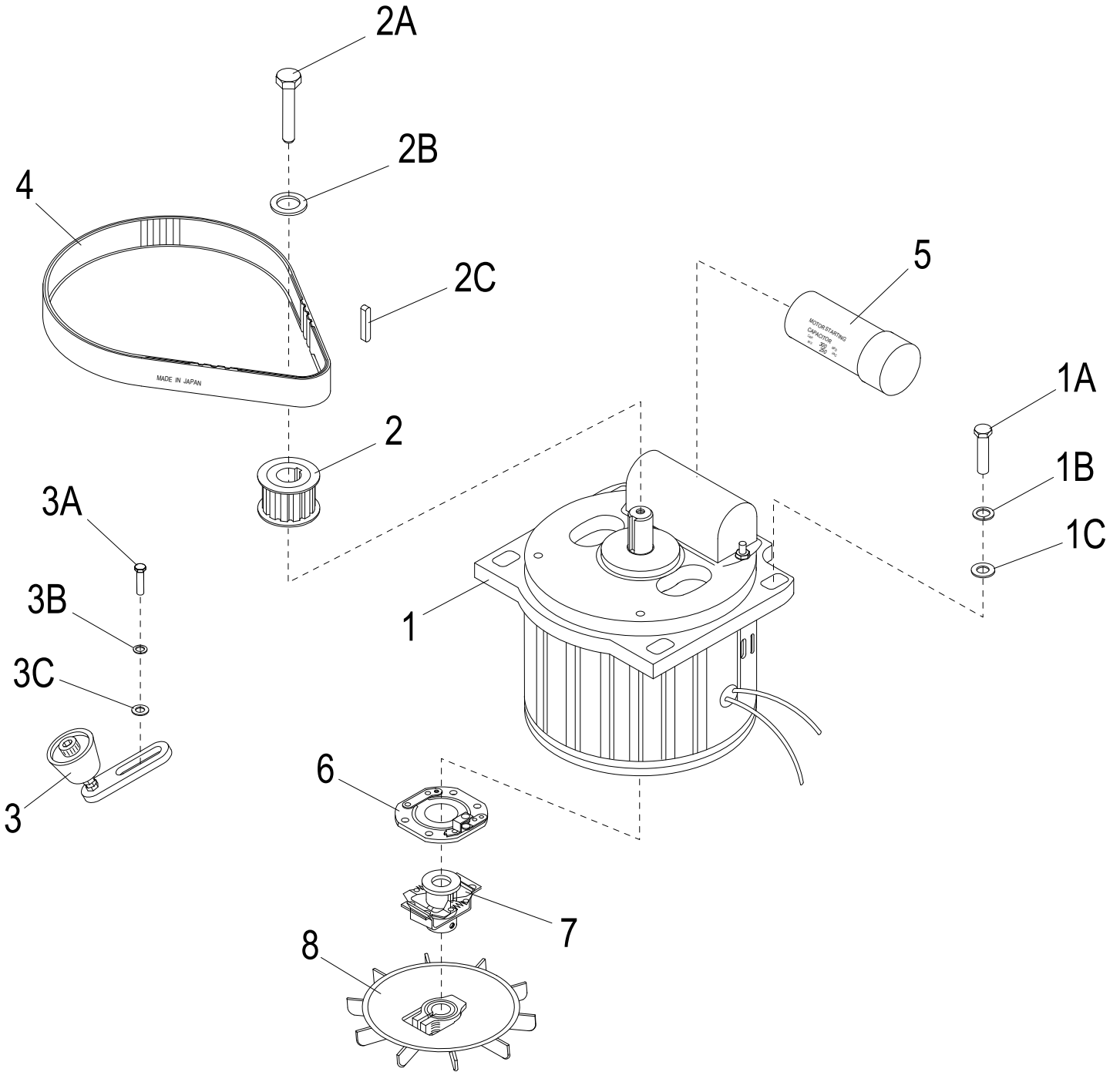



SPC40 Motor Components

Item	Part Number	Description	Qty	Serial Number
1	X40068-1C	Motor, SP40P 2HP 208/60/3 - Motor Brake (SPC40P-3)	3 Phase	1
1	X40068-2C	Motor, SP40P 2HP 220/60/1 - Motor Brake (SPC40P-1)	1 Phase	1
1A	X40069	Screw M8x30mm Hex Hd		4
1B	X08102	Lock Washer M8 ID-8.5, OD-14.8, TH-2mm Zn		4
1C	X08076	Flat Washer, M8 ID-8.4mm, OD-16mm, TH-1.6mm, Zn		4
2	X30071	Wheel, Motor Cog (18T) 60HZ		1
2	X00734	Wheel, Motor Cog (20T) 50HZ		1
2A	X40075	Ext. Hex Hd Screw M8x20mm Zn		1
2B	X30074	Flat Washer M8, ID-8, OD-24, TH-2mm, Zn		2
2C	X30073	Shaft Key 5x5x25		1
3	X30158	Belt Tensioner		1
3A	X40159	Screw M8x24mm Hex Head		2
3B	X08102	Lock Washer M8 ID-8.5, OD-14.8, TH-2mm Zn		2
3C	X08076	Flat Washer, M8 ID-8.4mm, OD-16mm, TH-1.6mm, Zn		2
4	X40072-1	Cogged Belt (S8M-880)		1
4	X40072-2	Cogged Belt (S8M-896)		1
5	X30070-1	Capacitor, Start 400MF	Replace parts w/Same Elect. Rating	1
5	X30070-1A	Capacitor, Start 600MF	Replace parts w/Same Elect. Rating	1
5	X40070-2	Capacitor, Run 50MF	Replace parts w/Same Elect. Rating	1
5	X60070-2	Capacitor, Run 70Mf	Replace parts w/Same Elect. Rating	1
6	X10051	Switch, Platinum		1
7	X40064	Clutch		1
8	X40061	Cooling Fan		1



SPC40 Motor Brake Components

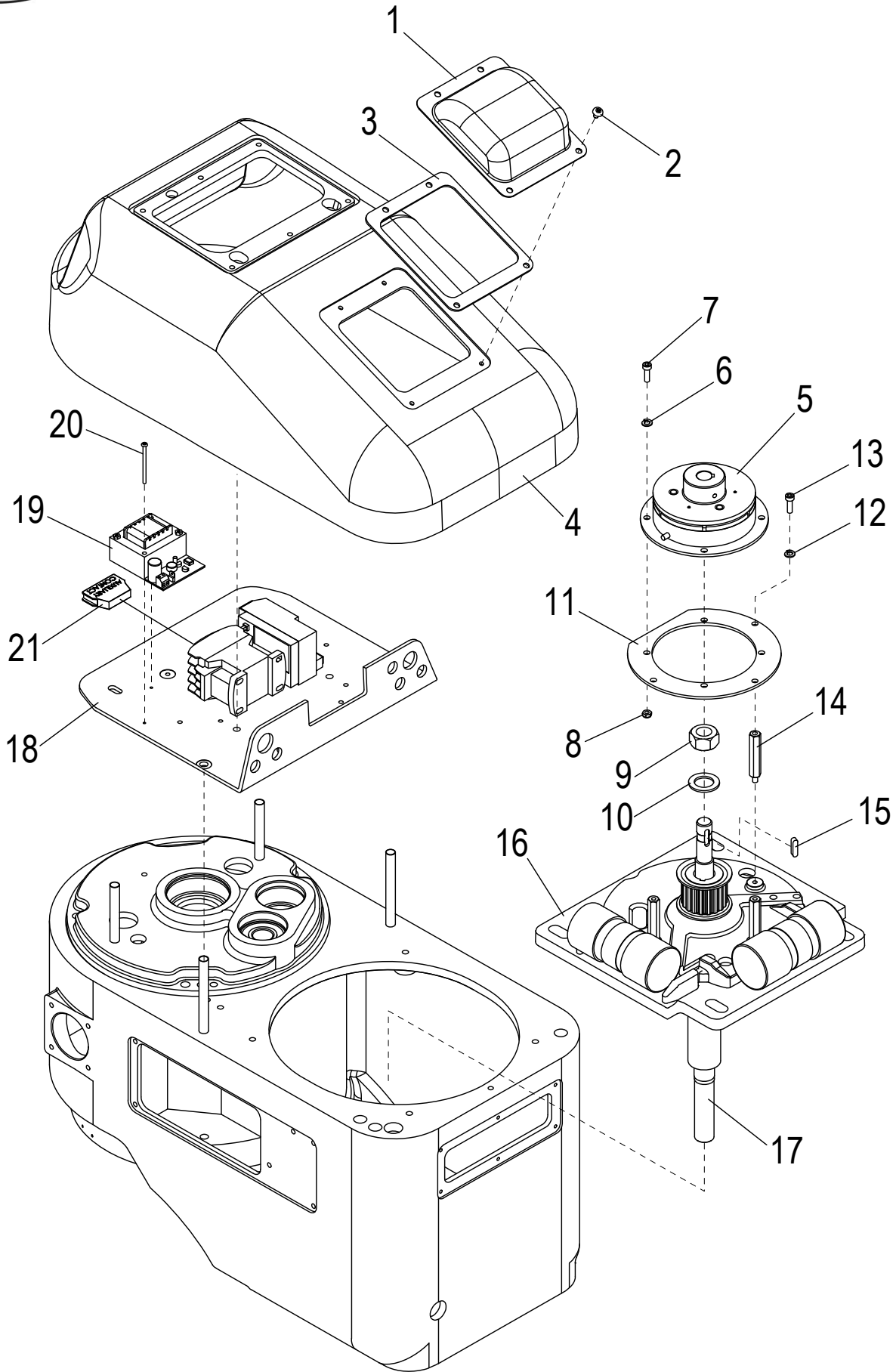



SPC40 Motor Brake Components

Item	Part Number	Description	Qty	Serial Number
1	X25500	Cover, Motor Brake Components	1	
2		Screw M5x10mm Button Hd	4	
3	X25500-1	Gasket	1	
4	X40004-1	Transmission Cover, Motor Brake Version	1	
5	X40501	Motor Brake, Magnetic	1	
6		Washer M5 Split Lock	4	
7		Cap Screw M5x12mm Socket Hd	4	
8		Nut M5 Hex	4	
9		Nut M18 Hex	1	
10		Washer M18 Flat	1	
11	X40500	Brake Housing	1	
13		Screw M5x10mm Socket Hd	3	
14	X30502	Hex Standoff	3	
15		Shaft Key 5x5x17mm	1	
16		Top Cover, Motor (Incl. w/Motor Assembly)	1	
17		Motor Shaft (Incl. w/Motor Assembly)	1	
18		Plate, Electronic Component Mounting	1	
19	X20512-1	Electronic Board	1	
20		Screw M3x34mm Round Hd	2	
21	X25503	Auxiliary Contact Block	1	
-		Slicer Base	1	

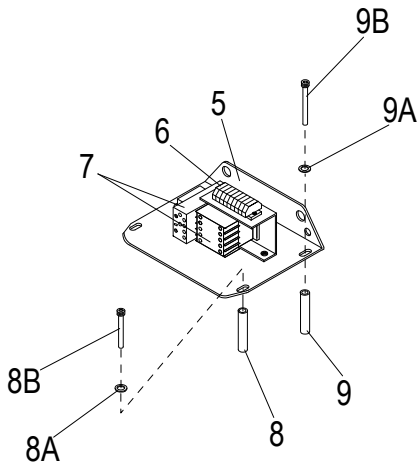
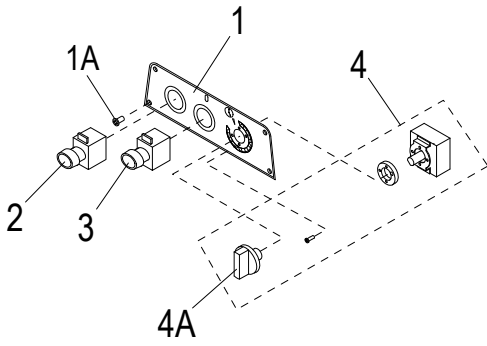

Manual Timer

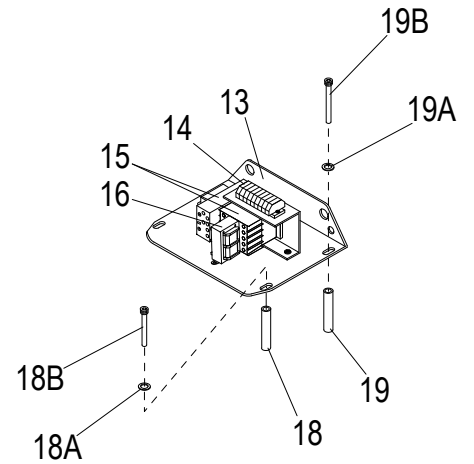
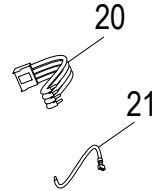
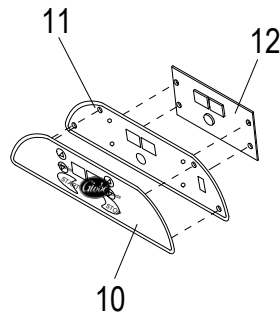

Digital Timer



SPC40 Manual and Digital Timer

Item	Part Number	Description	Qty	Serial Number
1	X40005	Control Panel	1	
1A	X30204	Screw M4x10mm Truss Hd	8	
1B	X40009	Gasket, Control Panel (Not Shown)	1	
2	X10050	Emergency Stop Button	1	
3	X30007	Start Button	1	
3A	X30007-1	Boot, Start/Stop Switch Button (Not Shown)	2	
3B	X30007-1B	Light Bulb, Start Button (Not Shown)	1	
4	X10137	Timer Assembly With Knob	1	
4A	X10137-1	Timer Knob	1	
5	X60013	Plate, Electronics Mounting	1	
6	X40012	Connecting Block Set	1	
6	X40012-EC	Connecting Block End Cap	1	
6	X40012-4R	Connecting Block, 4C Org	1	
6	X40012-2G	Connecting Block, 2C Gry	7	
7	X40154-1	Overload Relay/Contactor Kit, SP40 2HP 3 Phase	1	
7	X40154-2	Overload Relay/Contactor Kit, SP40 2HP 1 Phase	1	
8	X40153	Tube, Support - Front (67mm)	2	
8A		Washer M8 Flat	2	
8B	X30086	Socket Hd Cap Screw M8-1.25x100mm, B.O.	2	
9A		Washer M8 Flat	2	
9B	X30010	Socket Hd Cap Screw M8-1.25x90mm B.O.	2	
9	X40085	Tube, Support - Rear (89mm)	2	
10	X00567	Switch, Membrane	1	
11	X01338	Aluminum Panel	1	
12	X00568	Control Board	1	
13	X60013	Plate, Electronics Mounting	1	
14	X40012	Connecting Block Set	1	
14	X40012-2G	Connecting Block, 2C Gry	6	
14	X40012-4R	Connecting Block, 4C Org	2	
14	X40012-EC	Connecting Block End Cap	1	
15	X40154-1	Overload Relay/Contactor Kit, SP40 2HP 3 Phase	1	
15	X40154-2	Overload Relay/Contactor Kit, SP40 2HP 1 Phase	1	
16	X00569	Control Transformer Assembly	1	
17	X00570	Control Transformer Fuse (Not Shown)	1	
18	X40153	Tube, Support - Front (67mm)	2	
18A		Washer M8 Flat	2	
18B	X30086	Socket Hd Cap Screw M8-1.25x100mm, B.O.	2	
19	X40085	Tube, Support - Rear (89mm)	2	
19A		Washer M8 Flat	2	
19B	X30010	Socket Hd Cap Screw M8-1.25x90mm B.O.	2	
20	X00675	4 Wire Harness With Connector	1	
21	X00676	Single Wire With Quick Connect	2	



SPC40 Wiring Diagram, 220V Single Phase

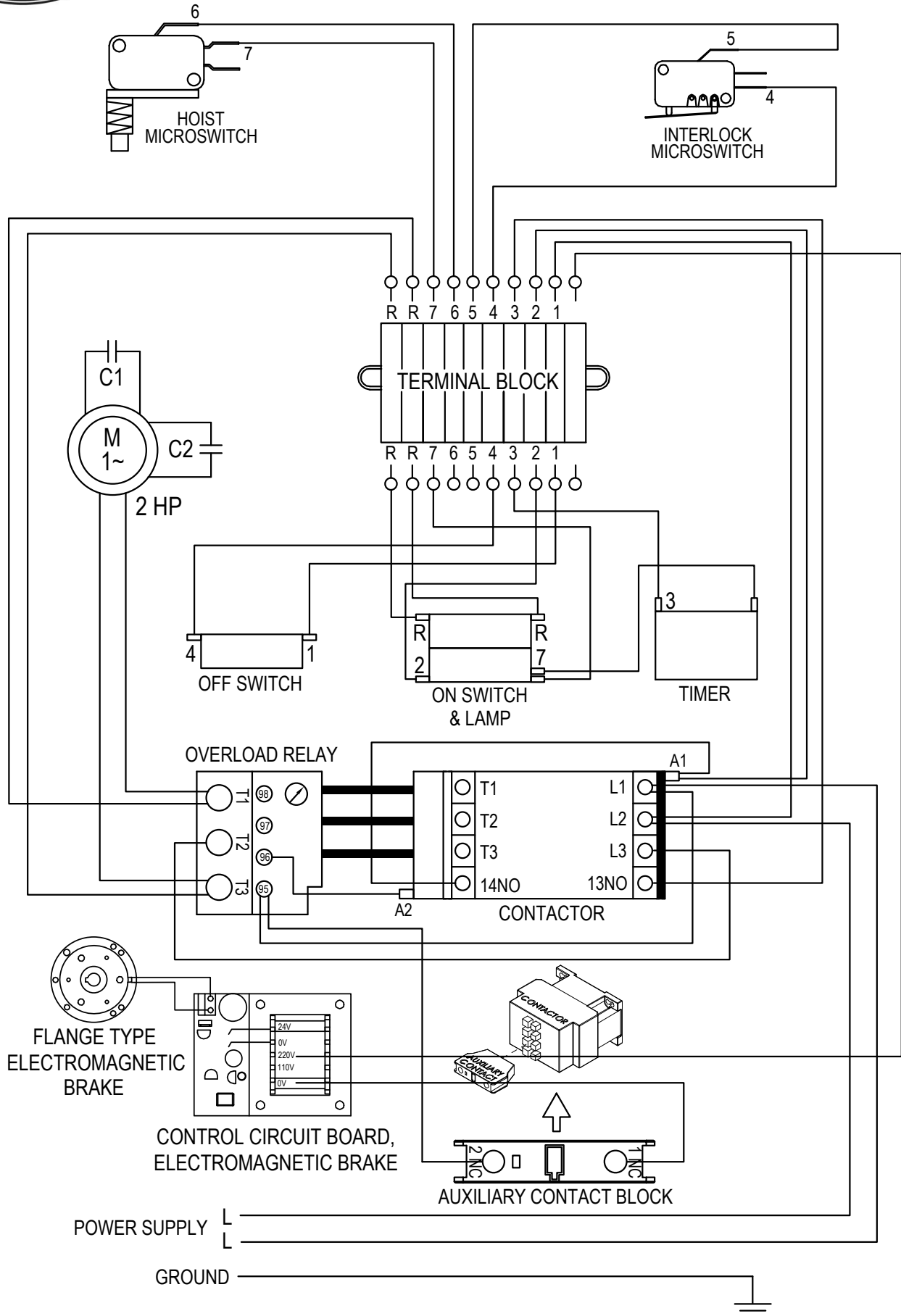



SPC40 Wiring Diagram, 208V Three Phase

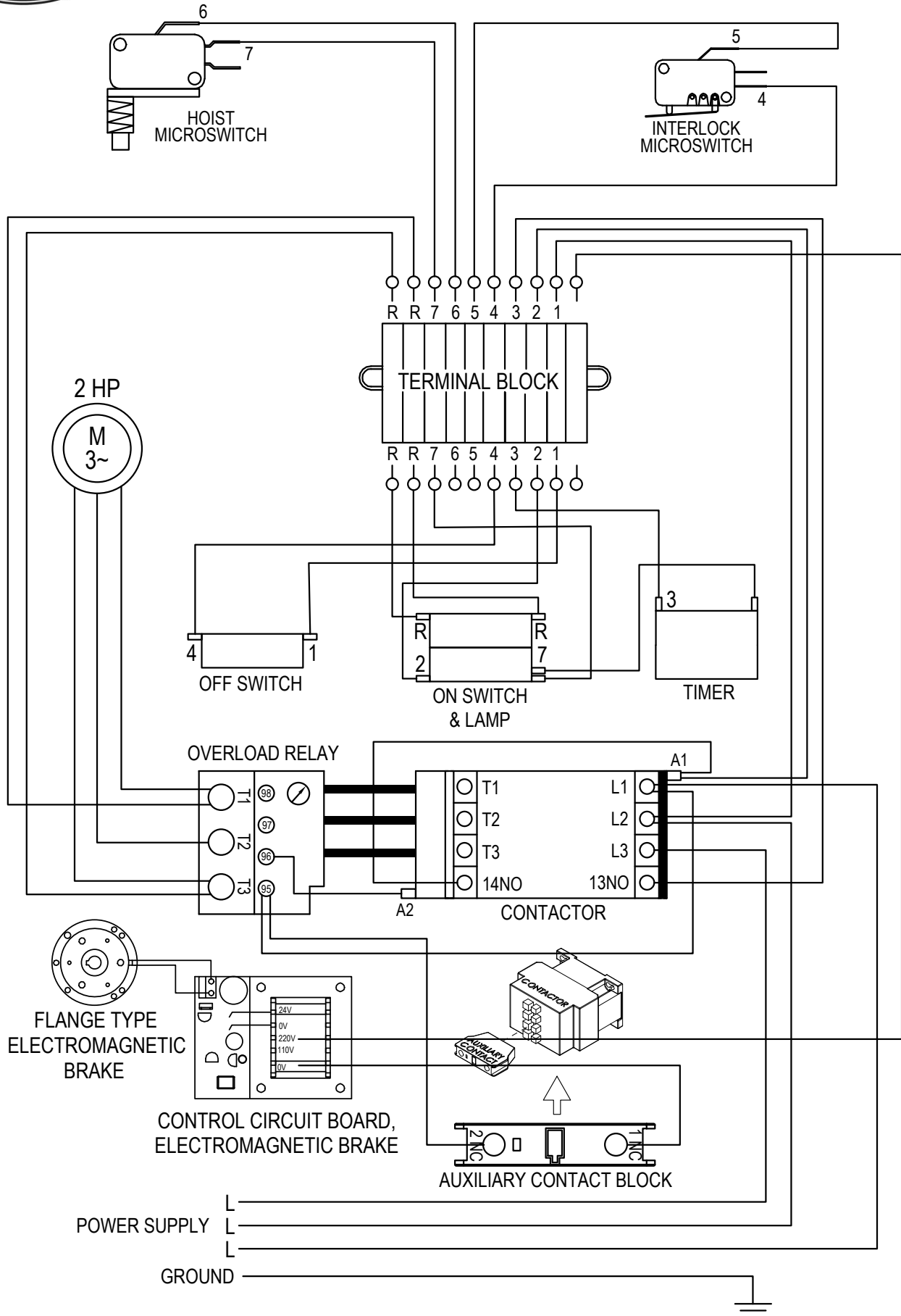



SPC40 Wiring Diagram, 220V Single Phase

