

? IMPORTANT INFORMATION? KEEP FOR OPERATOR? IMPORTANT INFORMATION ?

OPERATOR AND SERVICE MANUAL

Part Number 128416

OM/SM-AH-CE

INTERNATIONAL

Model: AH-CE Mark

Steam Jacketed Kettle

*Self-contained
Stainless Steel
Gas Heated
Floor Mounted
Stationary*

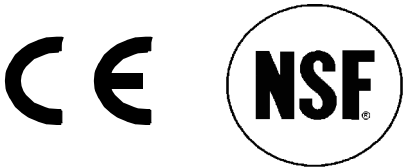

KEEP THIS MANUAL WITH KETTLE DOCUMENTS. OPERATORS AND TECHNICIANS SHOULD READ, UNDERSTAND AND FOLLOW WARNINGS AND INSTRUCTIONS IN THIS MANUAL (THE SERVICE MANUAL AND THE OPERATOR SECTIONS)



Information contained in this document is known to be current and accurate at the time of printing/creation. Unified Brands recommends referencing our product line websites, unifiedbrands.net, for the most updated product information and specifications.



IMPORTANT — READ FIRST — IMPORTANT

IT IS MOST IMPORTANT THAT THESE INSTRUCTIONS AND THE OPERATOR AND SERVICE MANUALS BE CONSULTED BEFORE INSTALLING AND COMMISSIONING THE APPLIANCE. FAILURE TO COMPLY WITH SPECIFIED PROCEDURES MAY RESULT IN DAMAGE OR THE NEED FOR A SERVICE CALL.

THESE APPLIANCES HAVE BEEN CE MARKED ON THE BASIS OF COMPLIANCE WITH THE GAS APPLIANCE DIRECTIVE, EMC AND LOW VOLTAGE DIRECTIVE FOR THE COUNTRIES, GAS TYPES AND PRESSURES AS STATED ON THE DATA PLATE.

THESE APPLIANCES MUST BE INSTALLED BY A COMPETENT PERSON IN CONFORMITY WITH THE INSTALLATION AND SERVICING INSTRUCTIONS AND NATIONAL REGULATIONS IN FORCE AT THE TIME. PARTICULAR ATTENTION MUST BE PAID TO THE FOLLOWING:

I. E. E. REGULATIONS FOR ELECTRICAL INSTALLATIONS
ELECTRICITY AT WORK REGULATIONS
GAS SAFETY (INSTALLATION AND USE) REGULATIONS
HEALTH AND SAFETY AT WORK ACT
LOCAL AND NATIONAL BUILDING REGULATIONS
FIRE PRECAUTIONS ACT

DETAILED RECOMMENDATIONS ARE CONTAINED IN INSTITUTE OF GAS ENGINEERS PUBLISHED DOCUMENTS: IGE/UP/1, IGE/UP/2, BS6173 AND BE5440.

FURTHERMORE, IF A NEED ARISES TO CONVERT THE APPLIANCE FOR USE WITH ANOTHER GAS, A COMPETENT PERSON MUST BE CONSULTED. THOSE PARTS WHICH HAVE BEEN PROTECTED BY THE MANUFACTURER MUST NOT BE ADJUSTED BY THE USER.

USERS SHOULD BE CONVERSANT WITH THE APPROPRIATE PROVISIONS OF THE FIRE PRECAUTIONS ACT AND THE REQUIREMENTS OF THE GAS SAFETY REGULATIONS. IN PARTICULAR THEY SHOULD BE AWARE OF THE NEED FOR REGULAR SERVICING BY A COMPETENT PERSON TO ENSURE THE CONTINUED SAFE AND EFFICIENT PERFORMANCE OF THE APPLIANCE.

WARNING: TO PREVENT SHOCKS, ALL APPLIANCES GAS OR ELECTRIC, MUST BE EARTHED.

UPON COMPLETION OF THE INSTALLATION, THE OWNERS MANUAL SHOULD BE HANDED TO THE USERS AND THE INSTALLER SHOULD INSTRUCT THE RESPONSIBLE PERSON(S) IN THE CORRECT OPERATION AND MAINTENANCE OF THE APPLIANCE.

THIS EQUIPMENT IS ONLY FOR PROFESSIONAL USE, AND SHALL BE OPERATED BY QUALIFIED PERSONS. IT IS THE RESPONSIBILITY OF THE SUPERVISOR OR EQUIVALENT TO ENSURE THAT USERS WEAR SUITABLE PROTECTIVE CLOTHING AND TO DRAW ATTENTION TO THE FACT THAT, SOME PARTS WILL, BY NECESSITY, BECOME VERY HOT AND WILL CAUSE BURNS IF TOUCHED ACCIDENTALLY.

WARNING: BEFORE REMOVING ANY PARTITION OR PANEL, ALWAYS TURN OFF THE ELECTRIC POWER AND ALLOW THE FAN TO STOP ROTATING. BEFORE WORKING ON ANY ELECTRICAL COMPONENT, DISCONNECT THE POWER SOURCE FROM THE UNIT.

NOTE: IT IS IMPORTANT THAT THE END-USER ROUTINELY EXAMINE THE FLUE OUTLET ON A REGULAR BASIS. DEBRIS COVERING THE FLUE OUTLET CAN CAUSE A POTENTIALLY HAZARDOUS CONDITION. REMOVE ANY FOREIGN MATERIAL BEFORE USING THIS PIECE OF EQUIPMENT.

WARNINGS AND CAUTIONS PROVIDED IN THIS OPERATOR AND SERVICE MANUAL MUST BE COMPLIED WITH.

TABLE OF CONTENTS

Section		Page
	Introduction	4
1	Installation	4
1.1	Model Numbers, Net Weights & Dimensions	5
1.2	Siting	5
1.3	Clearances	5
1.4	Ventilation	5
1.5	Electrical Supply	5
1.6	Gas Supply	5
1.7	Water Supply	5
1.8	Total Gas Rate	6
1.9	Injector Diameters-Natural and Propane Gas	6
1.10	Gas Pressure Adjustment	6
1.11	Burner Adjustment	6
2	Assembly and Conditioning	6
2.1	Assembly	6
2.2	Gas Supply	6
2.3	Electrical Supply	6
2.4	Jacket Water Level/Jacket Pressure	6
2.5	Pre-Commissioning Check	7
2.6	Instruction to Installer	7
3	Servicing and Conversion	8
3.1	Conversion	10
3.2	Jacket Vacuum	10
3.3	Jacket Filling	10
3.4	Water Treatment Procedure	10
3.5	Removal of Control Panel	11
3.6	Removal of Spark Ignition Module	11
3.7	Removal of Low Water Level Control	11
3.8	Removal of Gas Control Valve	11
3.9	ON/OFF Switch and Reset Button	11
3.10	Removal of Neons	11
3.11	Removal of Thermostat	12
3.12	Removal of Pressure Switch	12
3.13	Low Water Level Sensor	12
3.14	Removal of The Burner	13
3.15	Pilot Assembly	13
3.16	Removal of Pressure Gauge	13
3.17	Removal of Sight Glass	13
3.18	Safety Valve	14
3.19	Filling Valve	14
3.20	Fuse Replacement	14
4	Troubleshooting	15
5	User Instructions	17
5.1	Equipment Description	17
5.2	Lighting and Operation	18
5.3	Cleaning and Maintenance	21
	Wiring Diagram	23
	Parts Lists	24
	Service Log	30
	Warranty	31

Introduction

These Appliances have been CE marked on the basis of compliance with the Gas Appliance Directive, EMC and Low Voltage Directive for the Countries, Gas Types and Pressures as stated on the Data Plate.

These appliances MUST BE installed by a competent person in conformity with the INSTALLATION AND SERVICING INSTRUCTIONS and National Regulations in force at the time. Particular attention MUST be paid to the following:

- **I.E.E. Regulations for Electrical Installations**
- **Electricity at Work Regulations**
- **Gas Safety (Installation & Use) Regulations**
- **Health and Safety at Work Act**
- **Fire Precautions Act**
- **Local and National Building Regulations**

Furthermore, if a need arises to convert the Appliance for use with another gas, a competent person must be consulted. Parts which have been protected by the manufacturer MUST NOT be adjusted by the User.

Users should be conversant with appropriate provisions of the Fire Precautions Act and the requirements of the Gas Safety Regulations. In particular they should be aware of the need for regular servicing by a competent person to ensure the continued safe and efficient performance of the Appliance.

Upon completion of the installation, the Owners Manual should be handed to the users and the installer should instruct responsible person(s) in the correct operation and maintenance of the Appliance.

This equipment is ONLY FOR PROFESSIONAL USE, and shall be operated by QUALIFIED persons. It is the responsibility of the Supervisor or equivalent to ensure that users wear SUITABLE PROTECTIVE CLOTHING and to draw attention to the fact that, some parts will, by necessity, become VERY HOT and will cause burns if touched accidentally.

The Groen Steam Jacketed Kettle you have just purchased has been handcrafted from the finest materials, meticulously inspected, and carefully tested to ensure that you receive the best possible product. With reasonable care and periodic maintenance, it will provide years of faithful service. It is recommended that you establish a timetable for periodic maintenance as outlined in this manual.

Section 1 Installation

UNLESS OTHERWISE STATED, PARTS PROTECTED BY THE MANUFACTURER ARE NOT TO BE ADJUSTED BY THE INSTALLER.

1.1 Model Numbers, Net Weights and Dimensions

MODEL	WIDTH mm (in.)	DEPTH mm (in.)	HEIGHT mm (in.)	WEIGHT kg (lbs.)	CAPACITY Liters
AH-20	933 (36.7)	991 (38.9)	1016 (39.9)	213 (468)	75.7
AH-40	972 (38.1)	1143 (44.9)	1067 (41.9)	282 (620)	151.4
AH-60	1041 (40.9)	1245 (48.9)	1245 (48.9)	432 (950)	227
AH-80	1080 (42.4)	1295 (50.9)	1410 (55.4)	486 (1070)	303

WARNING

THE UNIT MUST BE INSTALLED BY PERSONNEL QUALIFIED TO WORK WITH ELECTRICITY AND GAS. IMPROPER INSTALLATION CAN CAUSE INJURY TO PERSONNEL AND/OR DAMAGE TO EQUIPMENT. THE UNIT MUST BE INSTALLED IN ACCORDANCE WITH ALL APPLICABLE CODES

1.2 Siting

Install the appliance on a level floor in a well-lit and draught-free position. Install the appliance in accordance with local and/or national regulations as listed in this manual.

1.3 Installing Clearances

Minimum clearances of 150 mm from the sides of the appliance and 150 mm from the rear of the appliance are required if the appliance is installed next to combustible surfaces.

Allow 1000 mm minimum clearance between the top rim of kettle and any overlying surface.

1.4 Ventilation

The unit must be installed in an adequately ventilated room with provision for an adequate air supply. The area around the appliance must be cleared of all combustible material. For multiple installations requirements for individual units should be added together. Installation must comply with applicable regulations. A competent installer must be employed.

CAUTION

THE APPLIANCE FLUE DISCHARGES VERTICALLY FROM THE TOP OF THE UNIT. IT MUST NOT BE DIRECTLY CONNECTED TO A FLUE, MECHANICAL EXTRACTION SYSTEM, OR DUCTING LEADING OUTSIDE THE BUILDING. THE APPLIANCE IS BEST DISCHARGED UNDER AN OPEN CANOPY CONNECTED TO A VENTILATING SYSTEM.

Recommendations for ventilation for catering appliances are given in BS 5440:2 and are shown in the table below.

Equipment	Ventilation Rate	
	m ³ /Min	ft ³ /Min
Range	17	600
Pastry Oven	17	600
Fryer	26	900
Grill	17	600
Steak Grill	26	900
Boiling Pan	17	600
Steamer	17	600
Sterilizing Sink	14	500
Bains Marie	11	400
Tea/Coffee Machine	8.5-14	300-500

1.5 Electrical Supply

This unit is designed for connection to fixed wiring. A suitably rated isolating switch with contact separation of at least 3 mm on both poles must be fitted to the installation and the wiring executed in accordance with the regulations listed in this manual.

Cable entry is at the lower rear on right hand side of the appliance. Access to the terminals is gained by removing relevant panels as described in Section 3.5 of this manual.

Provide 230 VAC, 50 Hz, 1 Phase, service. Rated input: 0.17 Amps, or 40 Watts. The electrical schematic is located in the service compartment and in this manual.

WARNING
THIS APPLIANCE MUST BE EARTHED.

1.6 Gas Supply

The incoming service must be of sufficient size to supply full rate without excessive pressure drop. A gas meter is connected to the service pipe by the Gas Supplier. Any existing meter should be checked by the Gas Supplier to ensure that the meter is of adequate capacity to pass the required rate of gas for the kettle in addition to any other gas equipment installed.

The appliance governor is incorporated in the gas control valve which is situated in the control cabinet.

The control valve governor is suitable for both natural and propane gases without any conversion.

Installation pipe work should be fitted in accordance with IEGE/UP/2. The pipe work should not be smaller than the gas inlet connection on the kettle, i.e. Rp ½ (½" B.S.P.)

An isolating cock must be located close to the appliance to allow shut down during an emergency or servicing. The installation must be tested for gas soundness and purged as specified in IGE/UP/1.

1.7 Water Supply

Not applicable to these appliances.

OM/SM-AH-CE

1.8 Total Gas Rate

Model	Natural (G20 & G25) KW	Natural BTU/hr	Propane (G31) KW	Propane BTU/hr
AH-20	22	75,100	22	75,100
AH-40	25	85,300	22	75,100
AH-60 & AH-80	40	136,500	40	136,500

1.9 Injector Diameters-Natural & Propane Gas

Model	Natural Gas G20 (mm)	Natural Gas G25 (mm)	Propane Gas G31 (mm)	No. of Orifices (Injectors)
AH-20	4.39	4.70	2.64	1
AH-40	4.57	4.90	2.64	1
AH-60 & AH-80	5.94	6.75	3.57	1

1.10 Gas Pressure Adjustment

A pressure test point is fitted on the burner manifold and on the gas control valve.

	Model	AH-20	AH-40	AH-60 & AH-80
NATURAL GAS G20	mbar	8.75	8.75	8.75
	in. WC	3.5	3.5	3.5
NATURAL GAS G25	mbar	8.75	8.75	7.0
	in. WC	3.5	3.5	2.8
PROPANE GAS G31	mbar	25	25	25
	in. WC	10	10	10

NOTE: With reference to the gas rate, pressure adjustments and conversions, this appliance is CE-approved for use with the following gases:

- G20 natural gas may be supplied to the appliance in Austria, Belgium, Denmark, Finland, France, Germany, Greece, Iceland, Ireland, Italy, Luxembourg, Norway, Portugal, Spain, Sweden, Switzerland and the United Kingdom.
- G25 natural gas may be supplied to the appliance in Belgium, France and the Netherlands.
- G31 propane gas may be supplied to the appliance in France, Germany, Ireland, the Netherlands, Portugal, Spain, Switzerland, and the United Kingdom.

Use of the appliance with non-approved gases in a listed country, or use in other countries will void CE certification.

1.11 Burner Adjustment

The burner has a primary air adjustment. The gap should be 1/4" (6.35 mm) to 3/8" (9.53 mm).

Section 2 Assembly and Commissioning

2.1 Assembly

- Unpack the appliance.
- Place on a firm, level floor. Adjust and fix feet.

Caution: Shipping straps are under tension and can snap back when cut. Take care to avoid personal injury or damage to the unit by staples left in the walls of the carton.

2.2 Gas Supply

Connect the unit to the gas supply and test for gas soundness. For the part of the integral gas supply down stream of the gas valve, leak detection spray or some solution may be used with the burners lit.

Caution: Ensure that the pan contains liquid when the burners are alight.

2.3 Electrical Supply

Before commissioning the appliance, ensure that the electrical installation has been carried out to the relevant regulations. (Paragraph 1.5)

THIS APPLIANCE MUST BE EARTHED.

2.4 Jacket Water Level/Jacket Pressure

- Ensure the water level is correct in the jacket, by confirming that the level is between the marks on the gauge glass. If the water is low, follow the instructions under "Jacket Filling" in the servicing section of this manual.
- Check the pressure gauge. If the gauge does not show 20 or more inches of vacuum (that is, a reading of 20 to 30 below zero) see "Jacket Vacuum" in the servicing section of this manual.

2.5 Pre-Commissioning Check

- a) Prior to operation, clean kettle pan with hot water and detergent. Rinse thoroughly.
- b) Remove all literature and packing materials from the interior and exterior of the unit.
- c) Ensure the open end or the elbow at the safety valve outlet is pointed down. If not, turn the elbow to the correct position. See Safety Valve Operation Instructions on Page 8.

2.5.1 Lighting Sequence

From Initial Start Up:

- a) Put a small amount of water in the kettle pan.
- b) Ensure gas and electricity mains are "on."
- c) Switch the toggle switch to the "on" position.
- d) Turn thermostat dial to desired setting.
- e) Observe that the burners ignite by the pilot lamp illuminating.
- f) If the unit does not ignite, it will lock-out. Turn the unit off and wait for one or two minutes before again attempting to switch it on.
- g) Press reset lock-out switch and repeat steps (b) to (e).
- h) To switch unit off, flip toggle (On/Off) switch to the "off" position.
- i) Turn gas and electricity mains off.

2.5.2 Setting The Gas Pressure

- a) Check gas pressure during commissioning. Connect a pressure gauge to the pressure test point on the burner manifold or the gas control valve. See figure for test points.
- b) When checking pressure at gas valve test points, undo the screw a half turn and slip tube over the nipple.
- c) Turn the main gas and electricity supplies on.
- d) Light the burners (Paragraph 2.5.1).
- e) Remove screws securing control cabinet side panel. (Paragraph 3.5).

- f) Remove governor cap screw on gas control valve. See figure for governor position on valve.
- g) Governor is suitable for natural and propane gas.
- h) To increase pressure turn the screw inside the governor turret clockwise, or anti-clockwise to reduce pressure. Check the burner pressure again after 15 minutes and adjust if necessary.
- i) Disconnect pressure gauge from the test point.
- j) Re-seal the pressure test point and test for gas soundness.
- k) Replace governor cap screw, lid and panels.

2.5.3 Checking Performance of Controls

- a) Light the unit (Paragraph 2.5.1). Check that the controls produce a healthy spark from the electrode to the earthing post and that ignition is smooth and without delay.
- b) Turn thermostat off and then on. Check that burners go out when switched off and ignite smoothly and quickly when switched back on. Repeat several times.
- c) If the unit fails to respond as described above contact an authorized Groen service agent.

2.6 Instruction to Installer

IMPORTANT

After installing and commissioning the appliance, the installer should hand the user's instructions to the user or purchaser. Ensure that the instructions for lighting, turning off, correct use and cleaning are properly understood. Emphasis should be made with regard to the location of the main gas isolating valve. The emergency shut down procedure should be demonstrated.

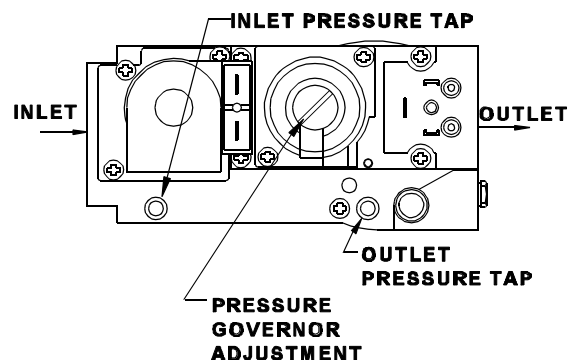

Section 3 Servicing and Conversion

IMPORTANT

BEFORE ATTEMPTING ANY SERVICING, ENSURE THAT THE ISOLATING COCK IS TURNED OFF AND CANNOT BE INADVERTENTLY TURNED ON, AND THAT THE ELECTRICITY SUPPLY IS DISCONNECTED.

AFTER ANY MAINTENANCE TASK, CHECK THE APPLIANCE TO ENSURE THAT IT PERFORMS CORRECTLY AND CARRY OUT ANY NECESSARY ADJUSTMENTS AS DETAILED IN SECTION 1.

ALWAYS CHECK FOR GAS SOUNDNESS AFTER CARRYING OUT ANY SERVICING OR EXCHANGE OF GAS CARRYING COMPONENTS !

NOTE: *When replacing wiring connections refer to the wiring diagram on the unit and in this manual.*

After Servicing

- a) Test for gas soundness as specified in IGE/UP1 as appropriate after any gas connection has been disturbed.
- b) Check for correct operation, as appropriate (see commissioning of appliance).

Regular Servicing Procedures

The following must be serviced at regular intervals.

Burners

The burner should be cleaned periodically to maintain maximum performance. The burner is best cleaned with a wire brush, taking care not to damage the burner head.

The injector orifice should be cleaned with a wooden splinter. Metal reamers may distort or increase the orifice size and should be avoided.

Safety Valve

At least once every two months the safety valve must be checked. When the gauge pressure is about five PSIG, lift the valve enough to vent steam, then quickly let it snap back into place.

This procedure should be explained to the user, as it is to be carried out at least twice a month. Safety procedures and requirements should also be explained to the user when carrying out the procedure.

Safety Valve Operating Instructions

If adding water to a boiler, **DO NOT ALLOW** water to flow through safety valve as sediment or debris may be deposited on seating surface.

To achieve topmost performance and maximum service life, it is necessary to maintain a proper pressure margin between set pressure of the safety valve and equipment operating pressure.

The minimum required pressure margin for this type of valve is 10% of the safety relief valve set pressure, but not less than five Pounds per Square Inch, Gauge (PSIG). **UNDER NO CIRCUMSTANCES SHOULD THIS MARGIN BE LESS THAN FIVE PSIG.!** Failure to maintain this margin may result in water leakage past the seat and an accumulation of deposits on the seating surface. Excessive deposits may prevent the valve from operating properly, and a dangerous pressure build-up and equipment rupture may result.

Maintenance and Testing

CAUTION! Before testing, make certain discharge pipe is properly connected to valve outlet and arranged to contain and safely dispose of boiler discharge (see "Installation Instructions").

Under normal operating conditions a "try lever test" must be performed every two months. Under severe service conditions, or if corrosion and/or deposits are noticed within the valve



**WARNING
AVOID ANY EXPOSURE TO THE STEAM
BLOWING OUT OF THE SAFETY VALVE.**

body, testing must be performed more often. A “try lever test” must also be performed at the end of any non-service period.

Test at or near maximum operating pressure by holding the test lever fully open for at least five seconds to flush the valve seat free of sediment and debris. Release the lever and let the valve snap shut. If lift lever does not activate, or there is no evidence of discharge, discontinue use of equipment immediately and contact a licensed contractor or qualified service personnel.

Neither Conbraco Industries, Inc. nor its agents assume any liability for valves improperly installed or maintained.

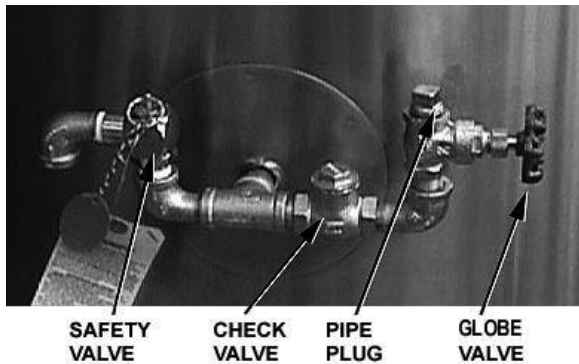

This quality Conbraco safety relief valve, with proper installation, use, and maintenance, will provide many years of reliable service and protection against excessive pressure build-up of water/steam. Use of this valve for any other purpose or media places all responsibility upon the user. Before installing valve or operating equipment to which it is installed, read instructions carefully. Always wear proper safety equipment.

INSTALLATION OF SAFETY VALVE
10-100, 10-200, 10-300, 10-500, & 10-600
Series

- a. Installation must be performed by qualified service personnel only.
- b. The Btu/hr or lb/hr rating of this valve must equal or exceed that of the equipment to which it is attached.
- c. DO NOT use this valve on a coal or wood boiler having an uncontrolled heat input.
- d. Ensure that all connections, including the valve inlet, are clean and free from any foreign material.

- e. Use pipe compound sparingly, or tape, on external threads only.
- f. **DO NOT USE A PIPE WRENCH!** Use proper type and size wrench on wrench pads only.
- g. This valve must be mounted in a vertical, upright position directly to a clean, tapped opening in the top of the boiler or equipment. Under no circumstances should there be a flow restriction or valve of any type between the safety relief valve and the pressure vessel.
- h. **WARNING!** During operation this valve may discharge large amounts of steam and/or hot water. Therefore, to reduce the potential for bodily injury and property damage, a discharge line **MUST** be installed that:

- 1) is connected from the valve outlet with no intervening valve and directed downward to a safe point of discharge
- 2) allows complete drainage of both the valve and the discharge line.
- 3) is independently supported and securely anchored so as to avoid applied stress on the valve.
- 4) is as short and straight as possible.
- 5) terminates freely to atmosphere where any discharge will be clearly visible and is at no risk of freezing.
- 6) terminates with a plain end that is not threaded.
- 7) is constructed of a material suitable for exposure to temperatures of 375° F or greater
- 8) is, over its entire length, of a pipe size equal to or greater than that of the valve outlet.

Use only schedule 40 pipe for discharge. (Do not use schedule 80, extra strong pipe or connections). **DO NOT CAP, PLUG, OR OTHERWISE OBSTRUCT DISCHARGE PIPE OUTLET!**

OM/SM-AH-CE

- i. See appropriate ASME Boiler and Pressure Vessel Code for additional installation instructions.

3.1 Conversion — NOTE: See Para 1.9 and 1.10 (Page 6) for important gas conversion information. **VERIFY THE TYPE OF GAS TO BE USED.** In the countries listed in Paragraph 1.10 all conversions must be for approved gas.

To change the type of gas used (e.g. G20 to G25 or G31 or the like), change the following:

Burner injector
Pilot orifice
Pressure setting
Data Plate

The governor spring does not need to be changed- only the pressure setting.

3.2 Jacket Vacuum

When the kettle is cold, a reading that is positive or near zero on the pressure/vacuum gauge indicates excess air in the jacket. Air in the jacket slows down the heating of the kettle.

To remove air:

- a. Light the unit (see Section 2.5.1).
- b. When the pressure/vacuum gauge reaches a positive reading of five PSIG, release air and steam by lifting the lever on the safety valve for about 1 second. Repeat this process a few times, then let the valve snap back into the closed position.

See detailed Instructions on Page 8 pertaining to Safety Valve installation and operation.



WARNING
AVOID ANY EXPOSURE TO THE STEAM
BLOWING OUT OF THE SAFETY VALVE.

3.3 Jacket Filling

The jacket has been charged at the factory with the proper amount of treated distilled water. You may need to restore the jacket water to its proper level, either because water was lost as steam during venting or because treated water was lost by draining.

The procedure for adding water is as follows:

- a. If you are replacing water lost as steam use distilled water. If you are replacing treated water that was removed from the jacket, prepare more as directed below.
- b. Allow the kettle to cool completely. Using the proper sized spanner, remove the pipe plug from above the globe valve.
- c. Open the globe valve and pour distilled or treated water in the pipe plug orifice. (See "Water Treatment Procedure," Paragraph 3.4). Hold the safety valve open while you pour, to let air escape from the jacket.
- d. Air introduced to the jacket during the filling operation must be removed to obtain efficient heating. (See "Jacket Vacuum" section 3.2).

See detailed Instructions on Page 8 pertaining to Safety Valve installation and operation.

3.4 Water Treatment Procedure

WARNING
READ AND FOLLOW ALL PRECAUTIONS
STATED ON THE LABEL OF THE WATER
TREATMENT COMPOUND TO AVOID
INJURY.

- a. Fill the mixing container with the measured amount of water required. (See Table). Use distilled water only.

Model	Kettle Capacity	Jacket Capacity (Approx)
AH-20	75.7 Liters	17 Liters
AH-40	151.4 Liters	26.5 Liters
AH-60	227.1 Liters	35.9 Liters
AH-80	302.8 Liters	43.5 Liters

- b. Hang a strip of pH test paper on the rim of the container, with about 3 cm of the strip extending below the surface of the water.
- c. Measure the water treatment compound you will be using. (One way is to add the compound to the water from a small measuring cup).
- d. Stir the water continuously, while you slowly add water treatment compound, until the water reaches a pH between 10.5 and 11.5. Judge the pH by frequently comparing the color of the test strip with the color chart provided in the pH test kit.
- e. Record the exact amounts of water and treatment compound used. These amounts may be used again, if the same sources of water and compound are employed to refill the jacket in the future. However, it is advisable to check the pH every time water is prepared for the jacket.
- f. For optimum performance, use correctly treated, distilled water.

3.5 Removal of Control Panel

- a. Remove the two screws at the panel base.
- b. Remove panel
- c. Replace in reverse order.

3.6 Removal of Spark Ignition Module - (Turn the gas and electricity mains off)

- a. Remove control panel (Paragraph 3.5).
- b. Disconnect electrical leads from spark ignition module.
- c. Remove retaining screws securing spark ignition module.
- d. Withdraw spark ignition module from supporting bracket.
- e. Replace in reverse order.

3.7 Removal of Low Water Level Control (Turn the gas and electricity mains off)

- a. Remove control panel (Paragraph 3.5)
- b. Remove low water level control from its base by undoing the two retaining clips.

- c. Replace in reverse order.

Ensure the low water level control is correctly oriented when repositioned.

3.8 Removal of Gas Control Valve - (Turn the gas and electricity mains off)

- a. Remove control panel (Paragraph 3.5)
- b. Disconnect electrical leads from control valve.
- c. Undo fittings on each side of control valve.
- d. Remove mounting screws from valve.
- e. Remove control valve from control cabinet.
- f. Replace in reverse order.

3.9 Removal of ON/OFF Switch and Reset Button - (Turn the gas and electricity

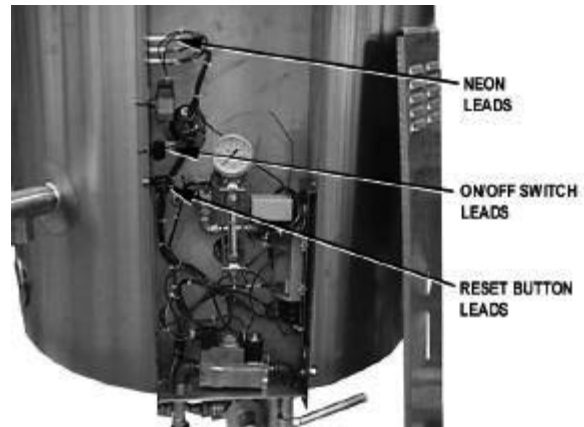

mains off)

- a. Remove control panel (Paragraph 3.5).
- b. Disconnect electrical leads from the On/Off switch or reset button.
- c. Undo and remove retaining collar which secures the On/Off switch to the outer surface of the control cabinet, and the reset button to its inner surface.
- d. Withdraw the On/Off switch or the reset button as required.
- e. Replace in reverse order.

OM/SM-AH-CE

3.10 Removal of Neons - (Turn the gas and electricity mains off)

- a. Remove control panel (Paragraph 3.5).
- b. Disconnect the electrical leads to the neon.
- c. Undo and remove the retaining collar which secures the neon to the control cabinet.
- d. Withdraw the neon from the control cabinet.
- e. Replace in reverse order.

3.11 Removal of Thermostat - (Turn the gas and electricity mains off)

- a. Remove control panel (Paragraph 3.5).
- b. Tilt the kettle slightly to move the water in the jacket away from the Phial Boss connection.
- c. Undo the Phial Boss connection and remove the thermostat Phial from the jacket.
- d. Remove thermostat control knob and disconnect electrical leads.
- e. Remove the two mounting screws that secure the thermostat to the control cabinet.
- f. Replace in reverse order. Ensure that an adequate sealant is used to seal the thermostat Phial Boss.



WARNING
ENSURE THAT THE OTHER ELECTRICAL LEADS AND CONNECTIONS SITUATED IN THE KETTLE BASE DO NOT GET WET. REMOVE THEM IF REQUIRED.

Important: If water is lost during thermostat removal replace as described in Paragraph 3.3, Jacket Filling.

Always refer to wiring diagram when reconnecting electrical leads. (See Page 23).



3.12 Removal of Pressure Switch - (Turn the gas and electricity mains off)

- a. Remove control panel (Paragraph 3.5).
- b. Disconnect the electrical leads from the pressure switch.
- c. Tilt the kettle slightly to move the water in the jacket away from the pressure switch pipe fitting.
- d. Remove and withdraw the pressure switch from the fitting.
- e. Replace in reverse order.
- f. Once the pressure switch is in place, ensure that the jacket water level is correct. See Paragraph 3.3, Jacket Fillings.

Always refer to wiring diagram when reconnecting electrical leads. (See Page 23)

3.13 Low Water Level Sensor - (Turn the gas and electricity mains off)

- a. Remove control panel (Paragraph 3.5).
- b. Disconnect the electrical lead from the water level sensor.
- c. Tilt the kettle slightly to move the water in the jacket away from the sensor coupling on the jacket

- d. Remove the low water sensor from the jacket.
- e. Replace in reverse order.
- f. Ensure a suitable sealant is used to seal the low water level sensor coupling.
- g. Once the low water level sensor is in place, check the jacket water level. See Paragraph 3.3, Jacket Fillings.

3.14 Removal of Burners - (Turn the gas and electricity mains off)

- a. Undo union on gas pipe to burner manifold.
- b. Remove the two retaining nuts securing the burner manifold to the combustion chamber.
- c. Carefully support the weight of the burner manifold and lower the assembly to a safe position.
- d. The burner is accessible and the orifice can be changed as required.
- e. Replace in reverse order.

Always check for gas soundness when any part of the gas circuit has been disturbed.

3.15 Removal of Pilot Assembly (Spark/Sensing Electrodes) - (Turn the gas and electricity mains off)

- a. Undo the compression fitting on the pilot line attached to the burner.
- b. Remove the two retaining screws securing the spark electrode/pilot bracket on the burner.
- c. Withdraw the pilot assembly from the burner chamber. The pilot orifice can now be changed as required
- d. Disconnect the high temperature lead wire connection to the sparking electrode or the sensing electrode as required.
- e. Replace in reverse order.
- f. Ensure that there is an adequate spark at the sparking electrode and that the burners light smoothly and without delay.

- g. Once the burners ignite, ensure that the sparking sequence stops and the burners remain lit.
- h. If the burners do not light, or ignite but do not remain lit, then adjustment to the sparking or sensing electrode is required.

3.16 Removal of Pressure Gauge - (Turn the gas and electricity mains off)

- a. Remove control panel (Paragraph 3.5).
- b. Using the correctly sized spanner remove the pressure gauge from the top of the sight glass.
- c. Replace with new pressure gauge ensuring that an adequate sealing compound is used.
- d. Once the pressure gauge has been replaced, the kettle jacket will need to be vented. See Paragraph 3.2, Jacket Vacuum.

3.17 Removal of Sight Glass - (Turn the gas and electricity mains off)

- a. Remove control panel (Paragraph 3.5).
- b. Remove sight glass protection bars.
- c. Undo top and bottom compression fittings.
- d. Allow the water in the sight glass to drain.
- e. Remove the sight glass.
- f. Replace in reverse order.
- g. Once the sight glass has been replaced, the lost jacket water needs to be replaced. See Paragraph 3.3. Jacket Filling.

3.18 Removal of Safety Valve - (Turn the gas and electricity mains off)

See detailed Instructions on Page 8 pertaining to Safety Valve installation and operation.

- a. Remove the elbow from the safety valve.
- b. Remove the safety valve from kettle jacket pipework.
- c. Replace in reverse order

OM/SM-AH-CE

- d. Ensure an adequate sealing compound is used to seal the safety valve.
- e) Once the safety valve has been replaced the jacket will need to be vented. See Paragraph 3.2 Jacket Vacuum.

3.19 Removal of Filling Valve - (Turn the gas and electricity mains off)

- a. Remove filling valve from kettle jacket pipework.
- b. Replace in reverse order.
- c. Ensure adequate sealing compound is used to seal the valve.

- d. Once the fill valve has been replaced the jacket will need to be vented. See Section 3.2 Jacket Vacuum.

3.20 Fuse Replacement - (Turn the gas and electricity mains off)

- a. Remove control panel (Paragraph 3.5).
- b. Remove fuse from vertical fuse holder.
- c. Replace fuse (identical to fuse removed)
- d. Replace in reverse order.

4. Troubleshooting

Your Groen kettle is designed to operate smoothly and efficiently if properly maintained. However, the following are checks to make in the event of a problem. Wiring diagrams are inside the service panel.

USE OF ANY REPLACEMENT PARTS OTHER THAN THOSE SUPPLIED BY GROEN OR THEIR AUTHORIZED DISTRIBUTORS CAN CAUSE INJURY TO THE OPERATOR AND DAMAGE TO THE EQUIPMENT AND WILL VOID ALL WARRANTIES.

SYMPTOM	WHO	WHAT TO CHECK
Burners will not light.	User	<ul style="list-style-type: none"> a. Is main gas valve open (handle in line with gas pipe)? b. Gas supply to your building. c. Is electric power turned on at the circuit breaker or fuse box, and is power being supplied to the appliance d. Thermostat operation.
Kettle continues heating after it reaches the desired temperature.	User	a. Thermostat dial setting.
	Auth Service Rep Only	<ul style="list-style-type: none"> b. Thermostat calibration. c. Thermostat operation. Thermostat should click when the dial is rotated above and below a setting.
Kettle stops heating before it reaches the desired temperature.	User	a. Thermostat dial setting.
	Auth Service Rep Only	<ul style="list-style-type: none"> b. Thermostat calibration. c. Thermostat. Thermostat should click when the dial is rotated above and below a setting.
Kettle heats slowly	User	a. Air in jacket - pressure/vacuum gauge (20 to 30 below zero when the kettle is cold?)
Safety valve pops.	User	<ul style="list-style-type: none"> a. Air in jacket - pressure/vacuum gauge (20 to 30 below zero when the kettle is cold?) b. Whether kettle was being heated while empty.
	Auth Service Rep Only	<ul style="list-style-type: none"> c. If high pressure limit switch is set too high. d. Thermostat. Thermostat should click when the dial is rotated above and below a setting. e. Safety valve. If valve pops below 300 PSIG, replace.
System does not produce a spark	Auth Service Rep Only	<ul style="list-style-type: none"> a. Thermostat: close the contacts if they are open b. AC voltage between terminals "1" and "GR." If it is not 230 Volt, check the high limit switch, which should be closed. c. That the high tension cable is firmly attached and in good condition. If cracked or brittle, replace the pilot. e. Electrode ceramic for crack or break. f. Replace the electronic spark ignition module.
Spark is present but the pilot will not light.	Auth Service Rep Only	<ul style="list-style-type: none"> a. That the gas valve is opening. b. That pressure meets the control manufacturer's specifications. c. For gas at the pilot. If it is not flowing: <ul style="list-style-type: none"> (1) Check pilot gas line for kinks or obstructions. (2) Clean orifice, if necessary. (3) Replace the pilot valve.
Pilot lights, but main burner will not come on and spark does not stay on.	Auth Service Rep Only	<ul style="list-style-type: none"> a. That the gas pressure meets the control manufacturer's specifications. b. Replace electric module

OM/SM-AH-CE

SYMPTOM	WHO	WHAT TO CHECK
Pilot lights, but main burner will not come on, the spark stays on.	Auth Service Rep Only	<ul style="list-style-type: none">a. Sensor cable, to make certain that there are secure attachments to terminal "13" and the sensor.b. Sensor ceramic for cracks.c. That cable is not grounded out. If it is, correct the ground.d. Sensor cable for continuity and condition of insulation.e. <ul style="list-style-type: none">(1) Check the gas pressure.(2) Clean the pilot Assembly.(3) Tighten mechanical and electrical connections.

5. User Instructions

Regulations and Safety Precautions

These Appliances have been CE marked on the basis of compliance with the Gas Appliance Directive, EMC and Low Voltage Directive for the Countries, Gas Types and Pressures as stated on the Data Plate.

These appliances **MUST BE** installed by a competent person in compliance with the **INSTALLATION AND SERVICING INSTRUCTIONS** and National Regulations in force at the time. Particular attention **MUST** be paid to the following:

**I.E.E. Regulations for Electrical Installations
Electricity at Work Regulations
Gas Safety (Installation & Use) Regulations
Health and Safety at Work Act**

Furthermore, if a need arises to convert the appliance for use with another gas, a competent person must be consulted. Those parts which have been protected by the manufacturer **MUST NOT** be adjusted by the User.

Users should be conversant with the appropriate provisions of the Fire Precautions Act and the requirements of the Gas Safety Regulations. In particular the need for regular servicing by a competent person to ensure the continued safe and efficient performance of the Appliance.



**WARNING
TO PREVENT SHOCKS, ALL APPLIANCES
WHETHER GAS OR ELECTRIC, MUST BE
EARTHED.**

Upon receipt of the User's Instruction manual, the installer should instruct the responsible person(s) of the correct operation and maintenance of the Appliance.

This equipment is **ONLY FOR PROFESSIONAL USE**, and shall be operated by **QUALIFIED** persons. It is the responsibility of the Supervisor or equivalent to ensure that users wear **SUITABLE PROTECTIVE CLOTHING** and to draw attention to the fact that, some parts will, by necessity, become **VERY HOT** and will cause burns if touched accidentally.

5.1

Equipment Description

5.1.1 General

Groen AH models are stainless steel, steam-jacketed, floor mounted, stationary kettles with a self-contained, gas heated steam source. The kettle body is welded into one piece and is sheathed in stainless steel and insulated with fiber bat insulation. The interior and exterior are given a bright buff finish.

The unit is ASME shop inspected and registered with the National Board for working pressure up to 30 PSIG. Kettle controls are contained in an enclosed stainless steel enclosure. The unit rests on tubular legs with adjustable ball feet. AH kettles come standard with stainless steel covers and two inch (five cm) sanitary tangent draw-off valve.

The self-contained steam source is heated by propane or natural gas. Ignition is by electronic spark.

The kettle is charged at the factory with treated, distilled water. The steam source provides kettle temperatures of 65° C to 134° C. Controls for the unit include a thermostat, pressure gauge, gauge glass, safety valve, pressure limit control, low water cut-off, on/off switch, and a multi-functional gas control valve.

Service connections are required for gas and 230-V, single phase 50-Hz electricity. See Paragraph 3.4 - Water Treatment.

IMPORTANT

Prior to operation, clean out the kettle pan thoroughly using hot water and detergent. Rinse out and dry completely.

OM/SM-AH-CE

The gas burners are protected by an electronic flame failure device which incorporates automatic ignition of the burners and instant shut-off of the gas supply to the burners should a gas supply interruption occur.



Options available with listed models are:

1. Three inch (7.6 cm) tangent draw-off valve. (Factory-installed option)
2. Basket inserts.
3. Water filler with swing spout and bracket.
4. Kettle brush kit.

5.1.2 Operational and Maintenance Safety

CAUTION
BE SURE ALL OPERATORS READ,
UNDERSTAND AND FOLLOW OPERATING
INSTRUCTIONS, CAUTIONS AND SAFETY
INSTRUCTIONS IN THIS MANUAL.

WARNING
INSTALLATION OF THE UNIT MUST BE
DONE BY PERSONNEL QUALIFIED TO
WORK WITH ELECTRICITY, GAS AND
PLUMBING IN ACCORDANCE WITH ALL
APPLICABLE CODES.

BEFORE REPLACING ANY PARTS,
DISCONNECT THE UNIT FROM THE
ELECTRIC POWER SUPPLY AND CLOSE
THE MAIN GAS COCK. ALLOW FIVE
MINUTES FOR UNBURNED GAS TO VENT.

TO PREVENT SHOCKS, ALL APPLIANCES
WHETHER GAS OR ELECTRIC, MUST BE
EARTHED.

5.2 Lighting and Operation

5.2.1 Initial Kettle Lighting and Operational Readiness Check

After the AH Kettle has been installed according to service and installation instructions, perform initial start-up as a test to ensure that the unit is operating correctly. Follow the steps below. Refer to the picture for identification of AH controls and indicators.

1. Remove all literature and packing material from the interior and exterior of the unit.
2. Make sure gas and electricity supplies are switched on.
3. Ensure that the kettle is filled with water before lighting.
4. Check the water level in the jacket. The level should be between the lines on the gauge glass. If the level is low, the jacket water level will be required to be topped up. (This will require a service call).
5. Check the pressure gauge. If the gauge does not show sufficient vacuum (that is, 20 to 30 below zero), the jacket will

require venting. (This will require a service call).

6. Switch the On/Off switch to the "On" position. The "power on" neon will illuminate.
7. Turn the thermostat dial to the required setting.
8. After 10-15 seconds the burners should light. The "burners on" neon will illuminate.
9. In the event the burners do not light, or go out as indicated by the illumination of the lockout indicating neon, turn the unit off. Wait approx 1 minute. Press lockout reset switch and repeat steps (4) to (8).

WARNING
AVOID CONTACT WITH THE FLUE.
SURFACES ARE VERY HOT AND WILL
CAUSE BURNS.

**DO NOT OBSTRUCT FLUE EXHAUST
OPENING.**

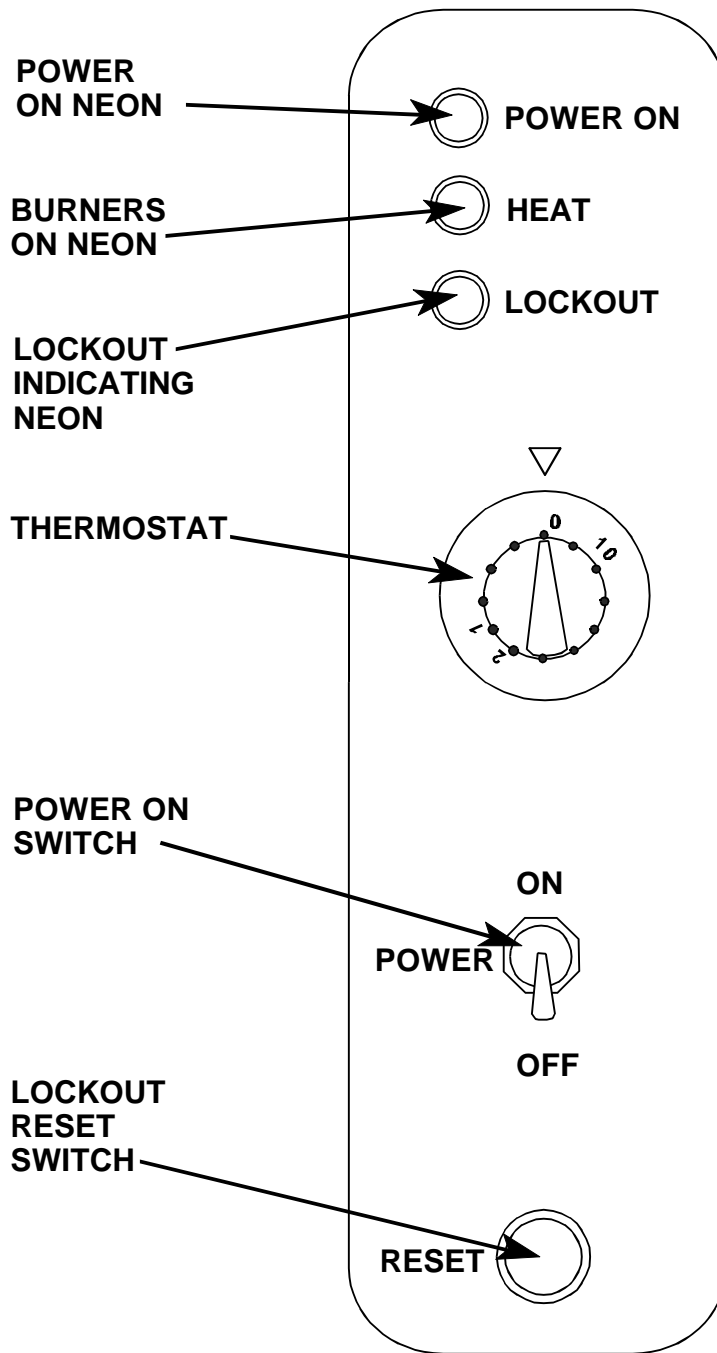

Controls on the AH-CE model are easy to understand and use.

OM/SM-AH-CE

5.2.2 To Shut Down Kettle

1. Turn the thermostat dial to the Off position.
2. Switch the On/Off switch to the Off position.
3. For a prolonged shut down follow steps 1 and 2, and turn the gas and electricity supplies off.

5.2.3 Filling the Kettle

Prior to operation of the unit, clean out the kettle pan thoroughly, using hot water and detergent.

Kettle Capacities:

Model	Capacity
AH-20	75.7 Liters
AH-40	151.4 Liters
AH-60	227.1 Liters
AH-80	302.8 Liters

Note that these are *maximum* capacities. Groen recommends that no more than 80% of the maximum capacity be used during operation.

5.2.4 Users Thermostat

The thermostat provides automatic control of the Kettle Jacket temperature at selected settings to a maximum of 134° C.

5.2.5 Sequence of Operation

The following "sequence of operation" outline is provided to help the user understand the functioning of the unit.

When the operator sets the desired temperature on the thermostat dial, the thermostat switch closes and sends a signal which (1) starts the spark and (2) opens the automatic valve for the burners. The spark ignites the burner on low flow. The flame completes a circuit at the sensing probe and sends a signal that causes the spark to shut off and the automatic valve to open to full flow once a flame has been detected. If a flame is not detected within 15 seconds the gas is automatically cut off and the appliance is locked out. The unit can only be re-lit once the reset button has been pressed.

In addition to the lockout timer, safety features include:

1. Low-water cutoff relay that will shut off the gas supply to all burners until the water level is corrected.
2. High pressure switch, set to open at about 27 PSIG and shut down the burners until jacket pressure is decreased.
3. Pop safety valve, which will release steam if the jacket pressure exceeds 30 PSIG.

See detailed Instructions on Page 8 pertaining to Safety Valve installation and operation.

When the kettle reaches the set temperature, the thermostat switch opens, stopping the signal to the gas control valve and causing the valve to shut off all gas flow. When the kettle cools below the set temperature, the thermostat switch closes and starts another heating cycle. On-off cycling continues and maintains the kettle at the desired temperature.

5.2.6 To Empty Kettle

Turn the handle on the tangent draw off valve anti-clockwise. After approximately 3½ turns the valve handle can be pulled forward and full flow achieved. To close the tangent draw off valve, push the valve handle inward until the threads on the valve stem engage. Turn the handle clockwise until the valve is closed. Do not over-tighten the valve since over-tightening may damage the valve seat.



WARNING
WHEN EMPTYING THE KETTLE BE CAREFUL TO KEEP HOT CONTENTS FROM SPILLING. AVOID DIRECT SKIN CONTACT. ENSURE PEOPLE ARE KEPT AWAY FROM THE KETTLE WHEN EMPTYING IT.

5.2.7 Power Failure

If power to the unit fails, do not attempt to operate the appliance until the electricity supply is reestablished.

When the power comes back on, follow the steps in Paragraph 5.2.1 (Initial Kettle Lighting and Operational Readiness Check.)

5.3 Cleaning and Maintenance

IMPORTANT

Disconnect the electricity supply before any cleaning is undertaken. The appliance must not be cleaned with a jet of water, nor steam-cleaned.

5.3.1 Suggested Tools

1. Detergent and sanitizing agent, or a combination cleaning - sanitizing agent.
2. Long handled and short handled kettle brushes.

5.3.2 Precautions

Before cleaning, shut off the burner by turning the thermostat dial to "OFF". If water or cleaning/sanitizing solution will be sprayed, shut off all electric power to the unit at a remote switch such as the circuit breaker.

WARNING
KEEP WATER AND SOLUTIONS OUT OF CONTROLS. NEVER SPRAY OR HOSE DOWN THE CONTROL CONSOLE.

5.3.3 Procedure

1. Clean all food contact surfaces as soon as possible after use, preferably while the kettle is still hot. If the unit is in continuous use, thoroughly clean and sanitize both interior and exterior **at least once every 12 hours**.
2. Scrape and flush out large amounts of food residues. Be careful not to scratch the kettle with metal implements.
3. Prepare a solution of the detergent/cleaning compound as instructed by the supplier. Clean the unit thoroughly. A cloth moistened with cleaning solution may be used to clean controls, control housings and electrical conduits.
4. As part of the daily cleaning program, clean all external and internal surfaces that may have been soiled. Remember to check such parts as the underside of the kettle and control housing.
5. To remove materials stuck to the equipment, use a brush, sponge, cloth,



Use a brush, sponge, cloth, plastic or rubber to remove materials stuck to the surface.

plastic or rubber scraper, or plastic wool along with the detergent solution. To minimize the effort required in washing, let the detergent solution sit in the kettle and soak into the residue, or briefly heat the detergent solution.

Do not use any abrasive materials or metal implement that might scratch the surface because scratches make the surface hard to clean and provide places for bacteria to grow. **DO NOT** use steel wool, which may leave particles imbedded in the surface and cause eventual corrosion and pitting.



Do not use metal implements or steel wool.

6. The exterior of the unit may be polished with a recognized stainless steel cleaner or with water and detergent.

OM/SM-AH-CE

7. When equipment needs to be sanitized, use a solution equivalent to one that supplies 200 parts per million available chlorine. Obtain advice on the best sanitizing agent from your products supplier. Follow the supplier's instructions and apply the agent after the unit has been cleaned and drained. Thoroughly rinse off the sanitizing agent.

CAUTION
NEVER LEAVE A CHLORINE SANITIZING AGENT IN CONTACT WITH STAINLESS STEEL SURFACES LONGER THAN 30 MINUTES. LONGER CONTACT CAUSES CORROSION.

8. It is recommended that the unit be sanitized before use.
9. If there is difficulty removing mineral deposits or a film left by hard water or food residue, clean the kettle thoroughly. Then use a de-liming agent, such as Groen Delimer Descaler (P/N 114800) or Lime-Away from EcoLab, Inc, in accordance with the manufacturer's directions. Rinse and drain the unit before further use.
10. If especially difficult cleaning problems persist, contact your cleaning product supplier for assistance.

5.3.4 Safety Precautions

A stopcock will be fitted in the gas pipe supplying the appliance. The user must be familiar with its location and operation so that it may be turned off in an emergency. If there is a smell of gas, turn off the gas, ventilate the area and call the gas supplier. Do not search for gas leaks with naked flames.

5.3.5 Service/Periodic Maintenance

A Maintenance and Service Log is included in this manual. Each time maintenance is performed on your Groen equipment, enter the date on which it was done, what was done, and who did it. Keep the manual, its warranty and the log near the unit. Periodic inspection can minimize equipment down time and increase the efficiency of operation. The following points should be checked regularly.

1. The pressure/vacuum gauge should show a vacuum of 20 to 30 inches when the kettle is cold. If it does not, the unit requires servicing.
2. The jacket water level should be between the marks on the gauge glass. If it is not, the unit requires servicing.
3. Keep electrical wiring in good condition.

Parts Lists

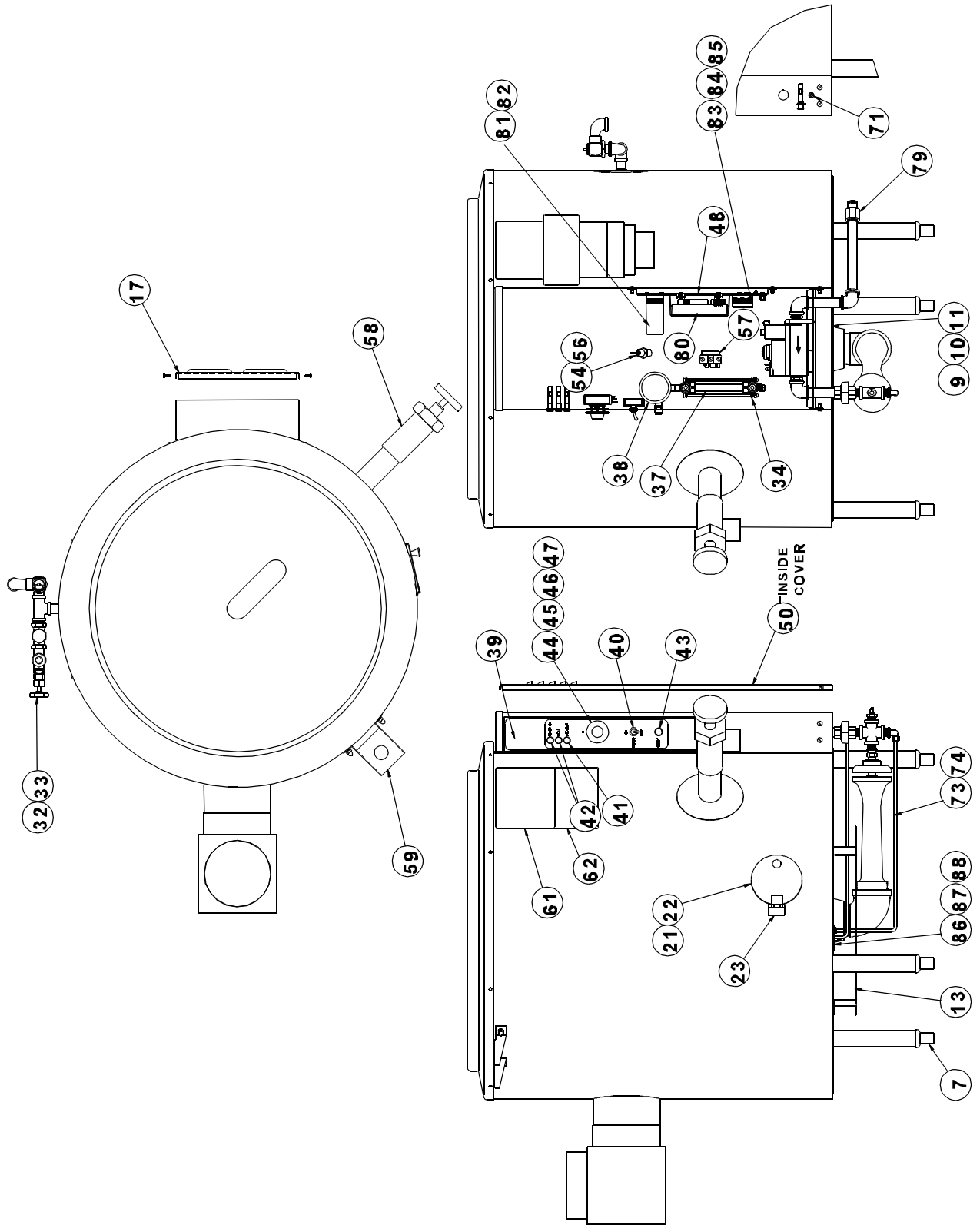

Parts Lists

Key	Description	Part No.	Key	Description	Part No.
7	Foot, Adjustable Bullet	013275	43	Switch Push Button (momentary)	122003
9	Bracket Burner Support, AH/1-60, -80	000388	44	Thermostat	012313
9	Bracket Burner Support, AH/1-20, -40	000336	45	Thermostat Adapter (shaft bushing)	107172
10	Bracket Burner Head AH/1-60, -80	000389	46	Screw, Rnd Hd slotted 8-32 x 3/8 lg	009697
10	Bracket Burner Head AH/1-20, -40	000337	47	Knob, Thermostat	122000
11*	Burner Assy. (Natural G20) (80 60)	117730A	48	Electrical Panel Assembly	117732
11*	Burner Assy. (Natural G20) (40)	117795A	50	Label, Wiring Diagram	113077
11*	Burner Assy. (Natural G20) (20)	117731A		Wire Harness **	117727
11*	Burner Assy. (Natural G25) (80 60)	117730C	54	Water Level Electrode	074665
11*	Burner Assy. (Natural G25) (40)	117795C	56	Boot Electrode	010390
11*	Burner Assy. (Natural G25) (20)	117731C	57	Pressure Switch, High Limit	108559
11*	Burner Assy. (Propane G31) (80, 60)	117730B	58	TDO Kit replacement parts	100573
11*	Burner Assy. (Propane G31) (40)	117795B	58a	Valve Stem	009048
11*	Burner Assy. (Propane G31) (20)	117731B	58b	Bonnet	009047
11*	Burner Injector (Natural G20) (80 60)	000399	58c	O-Ring	009034
11*	Burner Injector (Natural G20) (40)	000280	58d	Hex Nut	009354
11*	Burner Injector (Natural G20) (20)	000480	58e	Handle	009029
11*	Burner Injector (Natural G25) (80 60)	127386	58f	Wing Nut	009028
11*	Burner Injector (Natural G25) (40)	127385	59	Bracket, Faucet Mounting	009054
11*	Burner Injector (Natural G25) (20)	127384	61	Data Plate, CE Mark Kettles	114504
11*	Burner Injector (Propane G31) (80 60)	000403	62	Nameplate, Groen, Large	055450
11*	Burner Injector (Propane G31) (40)	000281	68	Cover Assy w/Power Aid AH/1-80**	047694
11*	Burner Injector (Propane G31) (20)	000281	68	Cover Assy w/Power Aid AH/1-60**	049884
13	Radiation Shield Assy, AH/1-60, -80	000445	68	Cover Assy w/Power Aid AH/1-40**	067417
13	Radiation Shield Assy, AH/1-20, -40	000448	68	Cover Assy w/Power Aid AH/1-20**	047695
17	Cover Panel, AH/1-80	117721		Users Manual**	122039
17	Cover Panel, AH/1-60	117720	71	Assembly, Equipotential Terminal	122021
17	Cover Panel, AH/1-40	117719	73	Wire Assembly, Supplementary	122013
17	Cover Panel, AH/1-20	117718	74	Wire Assembly, Flame Rod	122034
21	Insulator, Pilot Burner Access	008201	79	Adapter 1/2" BSPT (M) x 1/2"NPT (F)	116392
22	Door, Pilot Burner Access	004035	80	Pilot Ignition Controller	113060
23	Hinge, Pilot Door	004114	81	Liquid Level Control Relay	117737
32	Safety Valve & Water Fill Assembly	097010	82	Liquid Level Control Relay Base	117738
33	Plate with Chain Assembly	008332	83	Terminal Block	003119
34	Water Gauge Fitting	004071	84	Fuse (Three Amp)	079965
37	Sight tube, 5/8" Diameter x 4-3/4" lg	008742	85	Fuse Block	077854
38	Pressure Gauge 2-1/2" dia (dual scale)	084208	86	Pilot Burner & Orifice Assy (Natural)	117704
39	Overlay, Panel	117716+	87	Pilot Burner & Orifice Assy (Propane)	117705
40	Switch, Toggle, DPST	122004	88	Pilot Burner Mounting Bracket	004425
41	Light Indicator Red, 240V	116381	89	Water Treatment Kit	110324
42	Light Indicator, Amber 240V	116382			

*NOTE: See Para 1.10 (Page 6) for permissible conversions.

** Not Shown

Parts Lists

Keyed to Parts Listing on Page 29

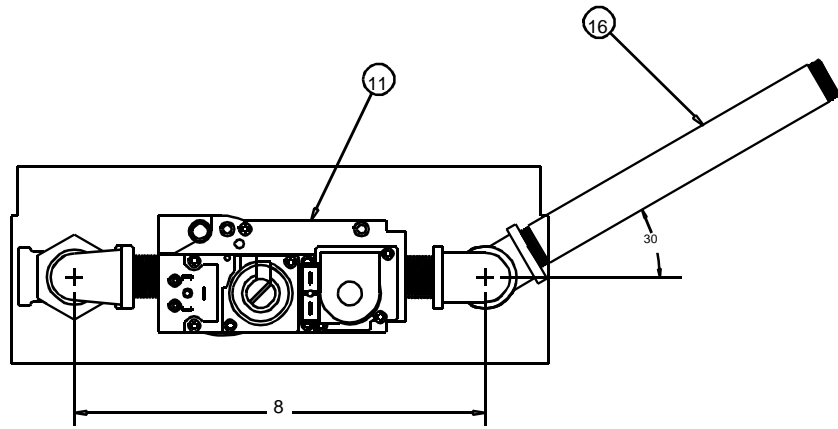

INSTALL WITH 1/2"BSPT THREADS
TOWARD GAS VALVE

INSTALL WITH 1/2"BSPT THREADS
TOWARD GAS VALVE

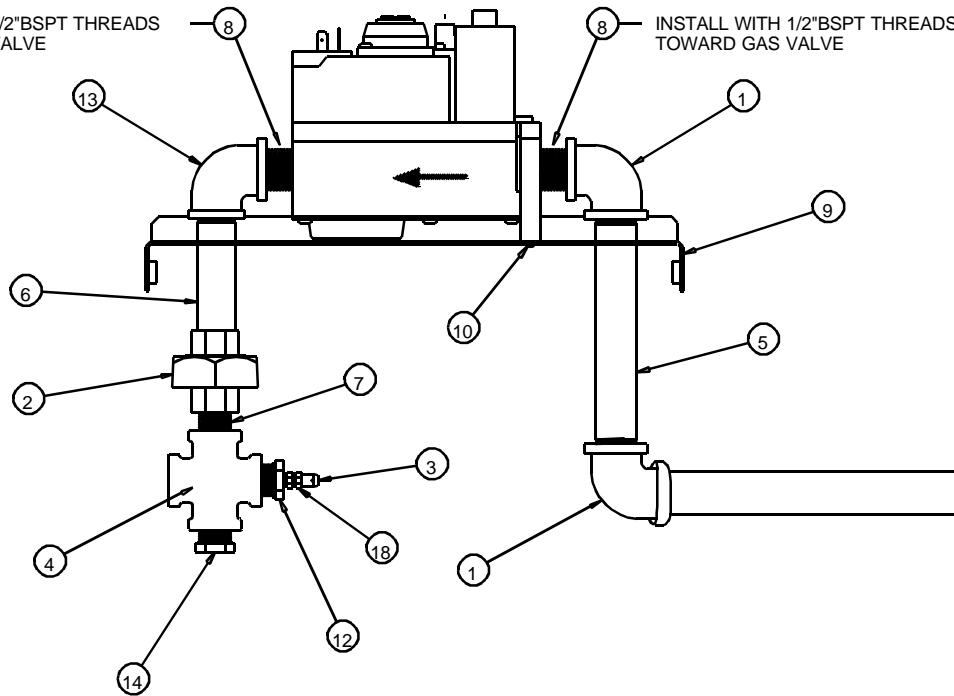

Gas Valve and Piping Assembly, AH/1-20

Parts List

Keyed to Parts Listing on Page 29

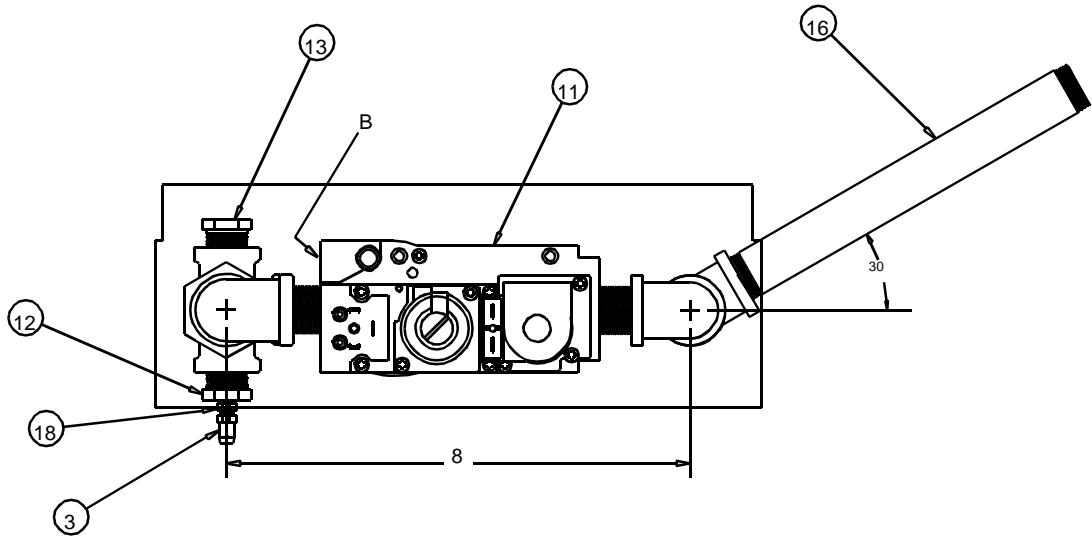

INSTALL WITH 1/2"BSPT THREADS
TOWARD GAS VALVE

INSTALL WITH 1/2"BSPT THREADS
TOWARD GAS VALVE

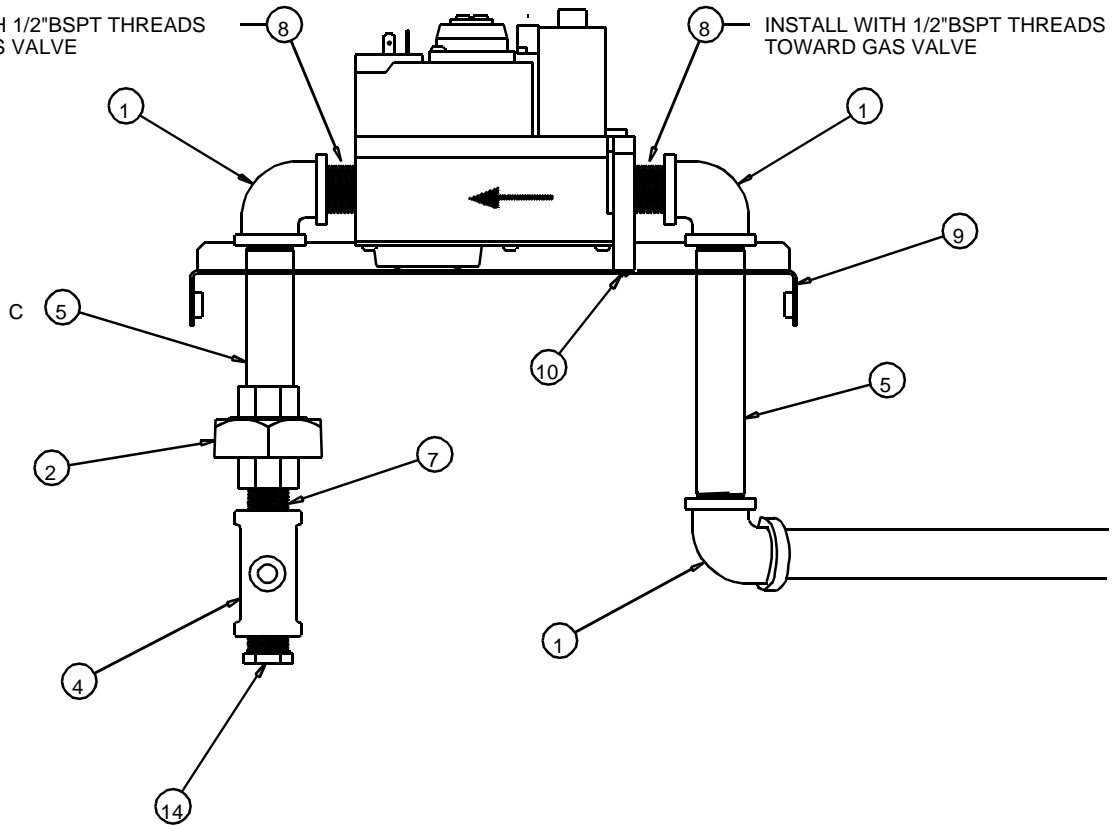

Gas Valve and Piping Assembly, AH/1-40

Parts List

Keyed to Parts Listing on Page 29

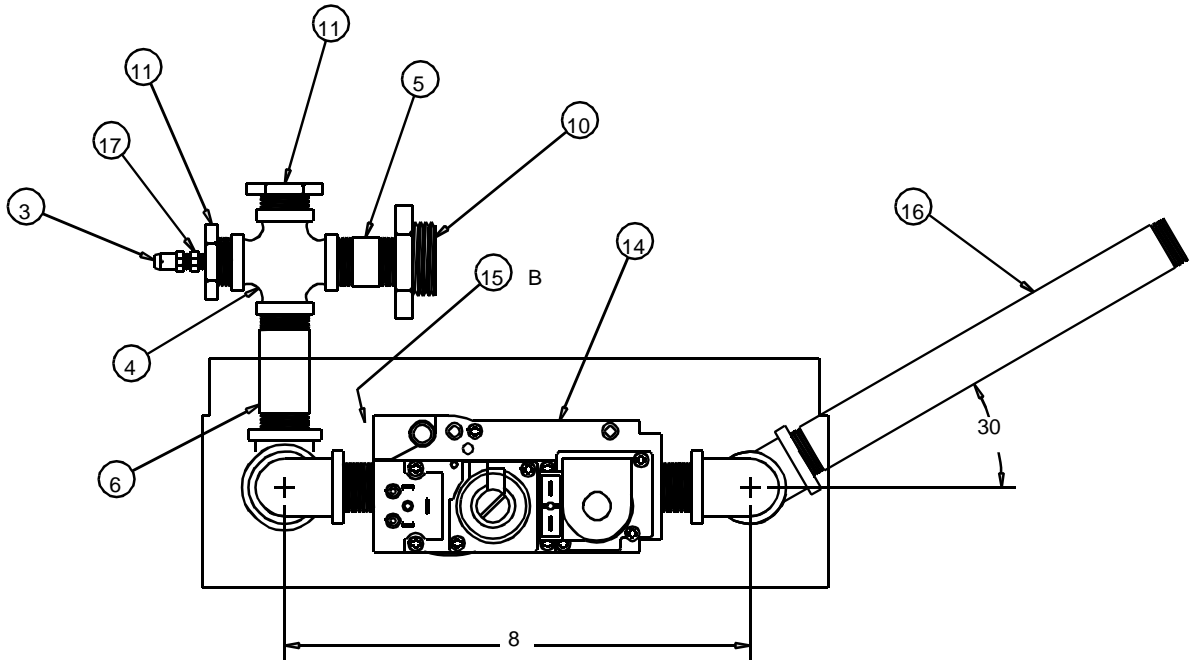

INSTALL WITH 1/2"BSPT THREAD TOWARDS GAS VALVE

INSTALL WITH 1/2"BSPT THREAD TOWARDS GAS VALVE

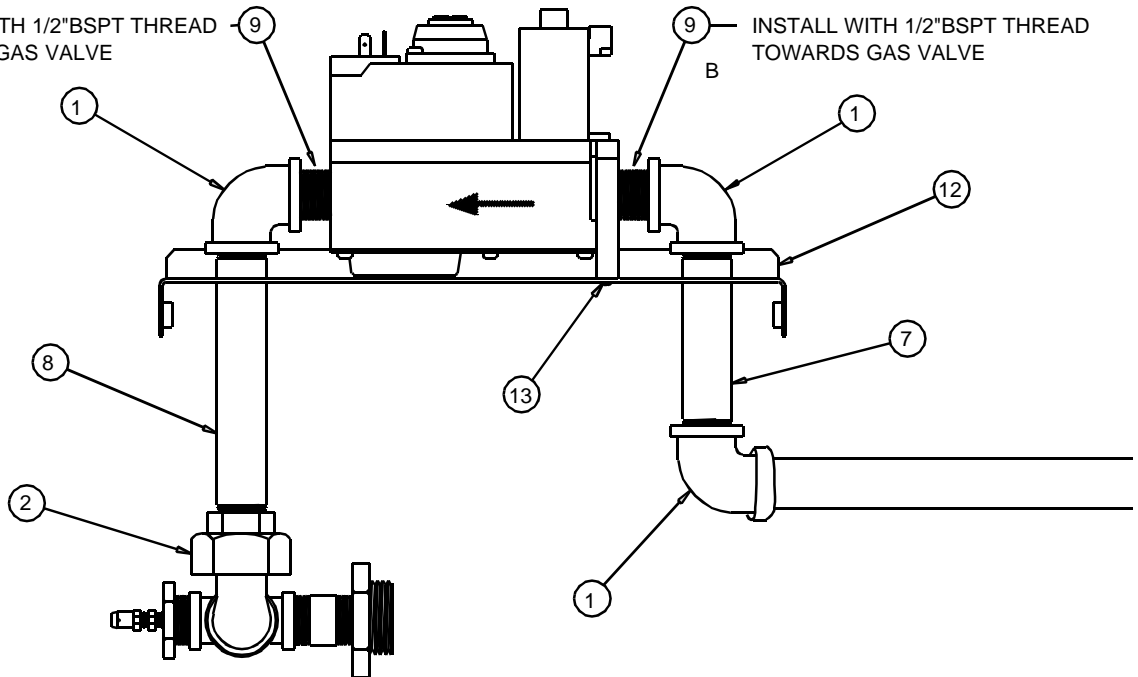

Gas Valve and Piping Assembly, AH/1-60, 1-80

Parts List

Key	Description	Part No.	Key	Description	Part No.
1	90° Elbow 1/2" NPT (black)	008747	9	Bracket, Gas Valve Mounting (AH-20)	122080
2	Union 3/8" NPT (black) (AH-20)	005686	10	Screw, Phillips Pan Hd M5 x 10 mm	116388
2	Union 1/2" NPT (black) (AH-40)	004186	11	Gas Valve	114505
2	Union elbow 1/2"NPT(black)(AH-60 80)	005495	12	Bushing Reducing 1/2" x 1/8" NPT (black) (AH-40, 60, 80)	088290
3	Gas Test Nipple	117051	12	Bushing Reducing 3/8"x 1/8" NPT (AH-20)	049943
4	Cross, 1/2" NPT (black) (AH-20)	060241	13	Bushing Reducing 1/2"x 3/8" NPT (AH-40)	007442
4	Cross, 3/8" NPT (black) (AH-40,60,80)	097587	13	Bushing Reducing 1/2" x 1/8" NPT (AH-60,80)	088290
5	Nipple 1/2" NPTx4"Lg. (black)	005554	14	Bushing Reducing 3/8" x 1/4" NPT (AH-20)	013296
6	Nipple 3/8" NPT x 4-1/2" Lg. (black) (AH-20)	005635	14	Bushing Reducing 1/2" x 1/4" NPT (AH-40)	008739
6	Nipple 1/2" NPTx4"Lg.(black)(AH-40)	005554	14	Bushing Reducing 1" x 1-1/2" NPT (AH-60,80)	002647
6	Nipple1/2"NPTx5-1/2"Lg.(black) (AH-60, 80)	010234	16	Nipple 1/2" NPT x 8 Lg. (black)	005557
7	Nipple, 3/8" NPT, close (black) AH-20	007439	19	Adaptor 1/8" Female BSPP x 1/8" Male NPT	122087
7	Nipple, 1/2" NPT, close (black) AH-40	008877			
7	Nipple, 1/2" NPT, 3"Lg (black) AH-60	005553			
7	Nipple, 1/2" NPT, 4"Lg (black) AH-80	005554			
8	Nipple 1/2" NPT x 1/2" BSPT (brass)	116394			
9	Bracket, Gas Valve Mounting (AH-40,60,80)	117717			

Limited Warranty To Commercial Purchasers*

(for Areas Outside of the U.S. and Canada)

Groen Foodservice Equipment ("Groen Equipment") has been skillfully manufactured, carefully inspected and packaged to meet rigid standards of excellence. Groen warrants its Equipment to be free from defects in material and workmanship for (12) twelve months from date of installation or (18) eighteen months from date of shipment with the following conditions and subject to the following limitations.

- I. This parts warranty is limited to Groen Equipment sold to the original commercial purchaser/users (but not original equipment manufacturers), at its original place of installation, in areas outside the U.S. and Canada.
- II. Damage during shipment is to be reported to the carrier, is not covered under this warranty, and is the sole responsibility of the purchaser/user.
- III. Groen, or an authorized service representative, will repair or replace parts, at Groen's sole election, for any Groen Equipment, including but not limited to, draw-off valves, safety valves, gas and electric components, found to be defective during the warranty period.
- IV. This warranty does not cover boiler maintenance, calibration, or periodic adjustments as specified in operating instructions or manuals, and consumable parts such as scraper blades, gaskets, packing, etc., or labor costs incurred for removal of adjacent equipment or objects to gain access to Groen Equipment. This warranty does not cover defects caused by improper installation, abuse, careless operation, or improper maintenance of equipment. This warranty does not cover damage caused by poor water quality or improper boiler maintenance.
- v. THIS WARRANTY IS EXCLUSIVE AND IS IN LIEU OF ALL OTHER WARRANTIES, EXPRESSED OR IMPLIED, INCLUDING ANY IMPLIED WARRANTY OF MERCHANTABILITY OR FITNESS FOR A PARTICULAR PURPOSE, EACH OF WHICH IS HEREBY EXPRESSLY DISCLAIMED. THE REMEDIES DESCRIBED ABOVE ARE EXCLUSIVE AND IN NO EVENT SHALL GROEN BE LIABLE FOR SPECIAL, CONSEQUENTIAL OR INCIDENTAL DAMAGES FOR THE BREACH OR DELAY IN PERFORMANCE OF THIS WARRANTY.
- VI. Groen Equipment is for commercial use only. If sold as a component of another (O.E.M.) manufacturer's equipment or if used as a consumer product, such Equipment is sold AS IS and without any warranty.

* (Covers All Food Service Equipment Ordered After October 1,1995)



1055 Mendell Davis Drive
Jackson, Mississippi 39272
Telephone 601 373-3903
FAX 601 373-9587

OM/SM-AH-CE
Part Number 128416
Revised 4/99