

OPERATOR MANUAL

IMPORTANT INFORMATION, KEEP FOR OPERATOR

This manual provides information for:

MODEL DEE/4 Domestic **STEAM JACKETED KETTLE**

- Self Contained
- Stainless Steel
- Floor Mounted
- Electrically Heated
- Tilting



THIS MANUAL MUST BE RETAINED FOR FUTURE REFERENCE. READ, UNDERSTAND AND FOLLOW THE INSTRUCTIONS AND WARNINGS CONTAINED IN THIS MANUAL.

FOR YOUR SAFETY

Do not store or use gasoline or other flammable vapors and liquids in the vicinity of this or any other appliance.

WARNING

Improper installation, adjustment, alteration, service or maintenance can cause property damage, injury or death. Read the installation, operating and maintenance instructions thoroughly before installing or servicing this equipment.

NOTIFY CARRIER OF DAMAGE AT ONCE

It is the responsibility of the consignee to inspect the container upon receipt of same and to determine the possibility of any damage, including concealed damage. Unified Brands suggests that if you are suspicious of damage to make a notation on the delivery receipt. It will be the responsibility of the consignee to file a claim with the carrier. We recommend that you do so at once.

Manufacture Service/Questions 888-994-7636.

Information contained in this document is known to be current and accurate at the time of printing/creation. Unified Brands recommends referencing our product line websites, unifiedbrands.net, for the most updated product information and specifications.

PART NUMBER 148783, REV. G (07/11)

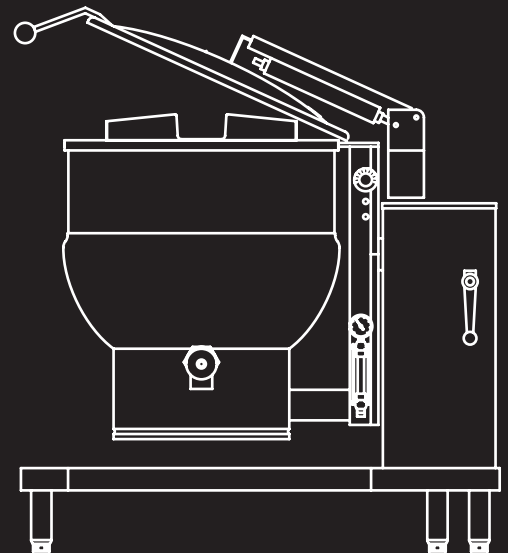

1055 Mendell Davis Drive
Jackson, MS 39272
888-994-7636, fax 888-864-7636
unifiedbrands.net

IMPORTANT - READ FIRST - IMPORTANT

- CAUTION:** BE SURE OPERATORS READ, UNDERSTAND AND FOLLOW THE OPERATING INSTRUCTIONS, CAUTIONS, AND SAFETY INSTRUCTIONS IN THIS MANUAL.
- WARNING:** THIS UNIT IS INTENDED FOR USE IN THE COMMERCIAL HEATING, COOKING, AND HOLDING OF WATER AND FOOD PRODUCTS, PER THE INSTRUCTIONS CONTAINED IN THIS MANUAL. ANY OTHER USE COULD RESULT IN SERIOUS PERSONAL INJURY OR DAMAGE TO EQUIPMENT AND WILL VOID WARRANTY.
- WARNING:** KETTLE MUST BE INSTALLED BY PERSONNEL QUALIFIED TO WORK WITH ELECTRICITY. IMPROPER INSTALLATION CAN RESULT IN INJURY TO PERSONNEL AND/OR DAMAGE TO EQUIPMENT.
- WARNING:** ELECTRICITY GROUND THE UNIT AT THE TERMINAL PROVIDED. FAILURE TO GROUND UNIT COULD RESULT IN ELECTROCUTION AND DEATH.
- WARNING:** AVOID ALL DIRECT CONTACT WITH HOT EQUIPMENT SURFACES. DIRECT SKIN CONTACT COULD RESULT IN SEVERE BURNS.
- WARNING:** AVOID ALL DIRECT CONTACT WITH HOT FOOD OR WATER IN THE KETTLE. DIRECT CONTACT COULD RESULT IN SEVERE BURNS.
- CAUTION:** DO NOT OVER FILL THE KETTLE WHEN COOKING, HOLDING OR CLEANING. KEEP LIQUIDS A MINIMUM OF 2-3" (5-8 CM) BELOW THE KETTLE BODY RIM TO ALLOW CLEARANCE FOR STIRRING, BOILING AND SAFE PRODUCT TRANSFER
- WARNING:** TAKE SPECIAL CARE TO AVOID CONTACT WITH HOT KETTLE BODY OR HOT PRODUCT WHEN ADDING INGREDIENTS, STIRRING OR TRANSFERRING PRODUCT TO ANOTHER CONTAINER.
- WARNING:** WHEN TILTING KETTLE FOR PRODUCT TRANSFER:
1. USE CONTAINER DEEP ENOUGH TO CONTAIN AND MINIMIZE SPLASHING.
 2. PLACE CONTAINER ON STABLE, FLAT SURFACE, AS CLOSE TO KETTLE AS POSSIBLE.
 3. DO NOT OVER FILL CONTAINER. AVOID DIRECT SKIN CONTACT WITH HOT CONTAINER AND ITS CONTENTS.
- CAUTION:** KEEP FLOORS IN FRONT OF KETTLE WORK AREA CLEAN AND DRY. IF SPILLS OCCUR, CLEAN IMMEDIATELY, TO AVOID SLIPS OR FALLS.
- WARNING:** FAILURE TO CHECK PRESSURE RELIEF VALVE OPERATION PERIODICALLY COULD RESULT IN PERSONAL INJURY AND/OR DAMAGE TO EQUIPMENT.
- WARNING:** WHEN TESTING, AVOID ANY EXPOSURE TO THE STEAM BLOWING OUT OF THE PRESSURE RELIEF VALVE. DIRECT CONTACT COULD RESULT IN SEVERE BURNS.
- WARNING:** TO AVOID INJURY, READ AND FOLLOW ALL PRECAUTIONS STATED ON THE LABEL OF THE WATER TREATMENT COMPOUND.
- WARNING:** BEFORE REPLACING ANY PARTS, DISCONNECT THE UNIT FROM THE ELECTRIC POWER SUPPLY AND CLOSE THE MAIN GAS VALVE. ALLOW FIVE MINUTES FOR UNBURNED GAS TO VENT.
- WARNING:** KEEP WATER AND SOLUTIONS OUT OF CONTROLS AND ELECTRICAL EQUIPMENT. NEVER SPRAY OR HOSE THE SUPPORT HOUSING OR ELECTRICAL CONNECTIONS. NEVER USE A HIGH PRESSURE HOSE TO CLEAN KETTLE SURFACES.

IMPORTANT - READ FIRST - IMPORTANT

CAUTION: MOST CLEANERS ARE HARMFUL TO THE SKIN, EYES, MUCOUS MEMBRANES AND CLOTHING. PRECAUTIONS SHOULD BE TAKEN. WEAR RUBBER GLOVES, GOGGLES OR FACE SHIELD AND PROTECTIVE CLOTHING. CAREFULLY READ THE WARNINGS AND FOLLOW THE DIRECTIONS ON THE LABEL OF THE CLEANER TO BE USED.

CAUTION: USE OF ANY REPLACEMENT PARTS OTHER THAN THOSE SUPPLIED BY AUTHORIZED DISTRIBUTORS CAN CAUSE OPERATOR INJURY AND DAMAGE TO THE EQUIPMENT, AND WILL VOID ALL WARRANTIES.

IMPORTANT: SERVICE PERFORMED BY OTHER THAN FACTORY AUTHORIZED PERSONNEL WILL VOID WARRANTIES.

WARNING: DO NOT HEAT AN EMPTY KETTLE. EXCESSIVE STEAM PRESSURE COULD DEVELOP.

Table of Contents

Important Operator Warnings	page 2-3
References	page 4
Equipment Description	page 5
Inspection and Unpacking	page 6
Installation	page 7
Initial Start-Up	page 8
Operation.....	page 9-10
Sequence of Operation	page 11
Cleaning	page 12-13
Maintenance	page 14-15
Troubleshooting	page 16-17
Parts List	page 18-20
Wiring Diagram	page 21
Service Log	page 22

References

NSF/ANSI-4

NFPA/70 The National Electrical Code

NATIONAL FIRE PROTECTION ASSOCIATION
60 Battery March Park
Quincy, Massachusetts 02269

NSF INTERNATIONAL
798 N. Dixboro Rd.
P.O. Box 130140
Ann Arbor, Michigan 48113-0140

UNDERWRITERS LABORATORIES, INC.
333 Pfingsten Road
Northbrook, Illinois 60062
UL/ANSU-197

Equipment Description



The DEE/4 is a floor-mounted, tilting, steam jacketed kettle with a thermostatically controlled, self-contained, electrically-heated steam supply and appropriate controls, mounted on a sturdy base. The kettle is available in 20, 40 or 60 gallon capacities.

The body of the kettle is constructed of stainless steel, welded into one solid piece. The kettle is furnished with a reinforced rim and a butterfly shaped pouring lip. It has a steam jacket rated for working pressures up to 50 PSI. Kettle finish is 180 emery grit on the inside and bright semi-deluxe on the outside.

The kettle can be tilted with a hand crank to pour out its contents. Stainless steel panels enclose the controls and the base. Four stainless steel, tubular legs support the unit. Bullet feet on each of the legs can be adjusted to level the kettle.

A built-in steam generator, sized for the kettle capacity and heated by electricity, delivers steam into the jacket. "Airless" operation of the steam jacket permits uniform, efficient heating at temperatures as low as 150°F and as high as 298°F. In addition to the adjustable thermostat for operating control, the unit has a tilt cut-off switch, low water cut-off, safety valve, and high limit pressure switch as safety features. A heating indicator light, pressure gauge, and sight glass are provided for monitoring kettle operation.

A single electrical connection is required for installation. The unit may be ordered for use with 208/240, 400 or 480 volt power. All kettles are wired for three-phase operation. Single-phase units are also available.

KETTLE CHARACTERISTICS			
Type	DEE/4-20	DEE/4-40	DEE/4-60
Capacity	20 Gallon (75 liter)	40 Gallon (150 liter)	60 Gallon (225 liter)
Inner Diameter	20 in (508 mm)	26 in (660 mm)	30 in (762 mm)
Rim Height	39 in (991 mm)	40 in (1016 mm)	44 in (1118 mm)
Width	38 in (965 mm)	42 in (1067 mm)	47 in (1194 mm)
Front-to-Back	28 in (711 mm)	32 in (813 mm)	35 in (889 mm)

Optional equipment available with kettles:

1. 2" or 3" diameter tangent draw-off (product valve)
2. Lift-off, hinged and power-assist covers
3. Water fill faucets
4. Basket cooking system
5. Kettle brush kit
6. Gallon etch marks

Inspection & Unpacking

CAUTION
SHIPPING STRAPS ARE UNDER TENSION AND CAN SNAP BACK WHEN CUT. TAKE CARE TO AVOID PERSONAL INJURY OR DAMAGE TO THE UNIT BY STAPLES LEFT IN THE WALLS OF THE CARTON.

CAUTION
THIS UNIT IS VERY HEAVY. INSTALLER SHOULD OBTAIN HELP AS NEEDED TO LIFT THIS WEIGHT SAFELY

The unit will arrive in a heavy shipping carton and will be bolted or banded to a skid. Immediately upon receipt, inspect the carton carefully for exterior damage.

Carefully cut any polyester straps around the carton and detach the sides of the box from the skid. Pull the carton up off the unit. Thoroughly inspect the unit for concealed damage. Report any shipping damage or incorrect shipments to the delivery agent.

Write down the model number, serial number, and installation date, and retain this information for future reference. Space for these entries is provided at the top of the Service Log at the back of this manual. Keep this manual on file and available for operators to use.

When installation is to begin, carefully cut any straps which hold the unit on the skid. Lift the unit straight up off the skid. Examine packing materials to be sure loose parts are not discarded with the materials.



Rear View

Installation

WARNING
INSTALLATION OF THE KETTLE MUST BE DONE BY A CERTIFIED ELECTRICIAN OR AUTHORIZED REPRESENTATIVE QUALIFIED TO WORK WITH ELECTRICITY. IMPROPER INSTALLATION CAN RESULT IN INJURY TO PERSONNEL AN/OR DAMAGE TO EQUIPMENT.

CAUTION
ELECTRICALLY GROUND THE UNIT AT THE TERMINAL PROVIDED. FAILURE TO GROUND THE UNIT COULD RESULT IN ELECTROCUTION AND DEATH.



The kettle is provided with complete internal wiring and is ready for immediate connection. Wiring diagrams are provided in this manual and on the inside of the control housing service panel. Any mechanical or electrical changes must be approved by the Food Service Engineering Department. The completed unit has been operated at the factory to test all controls and heater elements.

1. Set the kettle in place and level it by turning the bullet feet to adjust leg length. Allow clearance around the unit for cleaning, maintenance and service.
2. Confirm that the jacket water level is above the mid point of sight glass. If the level is low, follow the instructions under "Jacket Filling and Water Treatment," page 14.
3. The open end of the elbow on the outlet of the safety valve must face downward. If it does not, turn it to the correct position.
4. Provide electrical power specified on the equipment electrical information plate. Observe local codes and/or The National Electrical Code in accordance with ANSI/NFPA 70 - (current edition).
5. The equipment is shipped ready for three phase operation. Refer to the wiring diagram for single phase operation.
6. Bringing the electrical service through the entrance at the rear of the support housing with one inch conduit, making a watertight connection with the incoming lines. Observe local codes and/or the National Electrical Code in compliance with ANSI/NFPA 70 (latest edition). When there is a choice between applicable codes, we recommend following the more stringent code. (A BX connection is not recommended.)
7. Electrically ground the unit at the terminal provided.
8. Check the following to confirm that your kettle is properly installed:
 - Room for cleaning and servicing
 - The kettle is level
 - The correct amount of water is in the kettle jacket
 - Safety valve is pointed down
 - Unit is connected with a waterproof supply of the proper voltage, phase and amperage rating

ELECTRICAL SPECIFICATIONS						
	DEE/4-20		DEE/4-40		DEE/4-60	
	kW	Amps	kW	Amps	kW	Amps
208 Volt Single-Phase	11	52	21	102	21	102
208 Volt 3-Phase	11	30	21	59	21	59
240 Volt Single-Phase	14.4	61	24	106	24	106
240 Volt 3-Phase	14.4	35	24	61	24	61
480 Volt Single-Phase	12	25	24	50	24	50
480 Volt 3-Phase	12	15	24	29	24	29
400 Volt 3-Phase	12	17	24	35	24	35

Initial Start-Up

IMPORTANT
BE SURE ALL OPERATORS READ,
UNDERSTAND AND FOLLOW THE
OPERATING INSTRUCTIONS, CAUTIONS
AND SAFETY INSTRUCTIONS CONTAINED
IN THIS MANUAL.

WARNING
AVOID ALL DIRECT CONTACT WITH HOT
SURFACES. DIRECT SKIN CONTACT COULD
RESULT IN SEVERE BURNS.

AVOID ALL DIRECT CONTACT WITH HOT
FOOD OR WATER IN THE KETTLE. DIRECT
CONTACT COULD RESULT IN SEVERE BURNS.

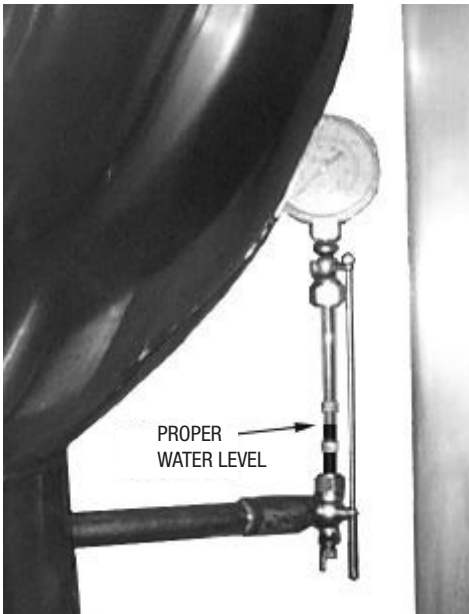

Each day, confirm the jacket water level by checking the water gauge.

Now that the kettle has been installed, you should test it to ensure that the unit is operating correctly.

1. Remove all literature and packing materials from inside and outside of the unit.
2. If the unit is equipped with a draw-off valve (product outlet, clean out any material which might clog or damage the draw-off).
3. Confirm that the tilting mechanism is operating properly by tilting the kettle through its full range. Then return the kettle to the upright position.
4. Turn on the electrical service to the unit.
5. Pour 1-2 quarts of water into the kettle.
6. Following “To Start Kettle” instructions in the “Operator” section of this manual, begin heating the water at the highest thermostat setting. The heating indicator light should come on immediately, and heating should continue until the water boils.
7. To shut down the unit, turn the thermostat dial to “OFF”.

If the unit functions as described above, it is ready for use. If the unit does not function as described, contact your local Certified Service Agency.

Operation

WARNING WHEN TILTING KETTLE

- 1) WEAR PROTECTIVE OVEN MITT AND PROTECTIVE APRON.
- 2) USE DEEP CONTAINER TO CONTAIN AND MINIMIZE PRODUCT SPLASHING.
- 3) PLACE CONTAINER ON STABLE, FLAT SURFACE, AS CLOSE TO KETTLE AS POSSIBLE.
- 4) STAND TO RIGHT OF KETTLE WHILE POURING—NOT DIRECTLY IN POUR PATH OF HOT CONTENTS.
- 5) POUR SLOWLY, MAINTAINING CONTROL OF KETTLE, AND RETURN KETTLE BODY TO UPRIGHT POSITION AFTER CONTAINER IS FILLED OR TRANSFER IS COMPLETE.
- 6) DO NOT OVERFILL CONTAINER. AVOID SKIN CONTACT WITH HOT CONTAINER AND ITS CONTENTS.

CAUTION
DO NOT OVERFILL THE KETTLE WHEN COOKING, HOLDING OR CLEANING. KEEP LIQUIDS AT LEAST 2-3" (5-8 cm) BELOW THE KETTLE BODY RIM TO ALLOW CLEARANCE FOR STIRRING, BOILING PRODUCT AND SAFE TRANSFER.

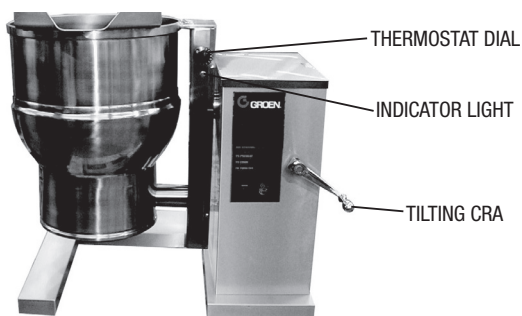

The operator controls kettle heating with the thermostat dial. The dial turns heating element power on or off and sets the kettle operating temperature.

A. To Start Kettle

1. EVERY DAY make sure that the jacket water level is between the markers on the gauge glass. If the level is too low, see “Jacket Filling and Water Treatment” on page 14.
2. Check the pressure gauge. If the gauge does not show 20 to 30 inches of vacuum (that is a reading of 20 to 30 below 0 atmospheric pressure), see “Jacket Vacuum” on page 14.
3. Turn on the electrical power to the unit.
4. Turn the thermostat to desired setting. The heat indicator light will come on. Cycling of the light on and off the shows that the kettle is being held at the set temperature. Once in each cycle the contactors in the support housing will make a clicking sound. This is normal.
5. If the unit does not light, turn it off and wait five minutes. Then follow the instructions again.

B. To Transfer Product or Empty Kettle

1. The kettle is tilted by means of a hand wheel on the front of the control housing. The kettle remains in the position to which tilted until turned again.
2. Product may also be transferred by means of the optional draw-off valve if the kettle is so equipped.

C. Common Accessories

1. Lift-Off Cover or Counterbalanced Cover
As with stock pot cooking, an optional cover can speed up the heating of water and food products. A cover helps retain heat and reduces the heat and humidity released into the kitchen. Using a cover can reduce some product cook times and help maintain the temperature, color and texture of products being held or simmered for longer periods.

Be sure the handle is secure on the lift-off cover before using. ALWAYS use the handle to place or remove cover from the kettle. Wear protective oven mitts and a protective apron.

When putting a lift-off cover on the kettle, position it on top of kettle rim, with its flat edge facing the pouring lip.

Operation

WARNING

AVOID ALL DIRECT CONTACT WITH HOT SURFACES. DIRECT SKIN CONTACT COULD RESULT IN SEVERE BURNS.

AVOID ALL DIRECT CONTACT WITH HOT FOOD OR WATER IN THE KETTLE. DIRECT CONTACT COULD RESULT IN SEVERE BURNS.

TAKE SPECIAL CARE TO AVOID CONTACT WITH HOT KETTLE BODY OR HOT PRODUCT, WHEN ADDING INGREDIENTS, STIRRING OR TRANSFERRING PRODUCT TO ANOTHER CONTAINER.

CAUTION

DO NOT TILT KETTLE WITH LIFT-OFF COVER IN PLACE. COVER MAY SLIDE OFF, CAUSING INJURY TO OPERATOR.

CAUTION

KEEP FLOORS IN FRONT OF THE KETTLE WORK AREA CLEAN AND DRY. IF SPILLS OCCUR, CLEAN AT ONCE TO AVOID SLIPS OR FALLS.



When removing a lift-off cover:

- a. Firmly grasp the handle
 - b. Lift rear edge (farthest from operator) 1-2" (3-5 cm) to allow steam and water vapor to escape the cooking vessel. Wait 2-3 seconds.
 - c. Tilt cover to 45-60° angle to allow any hot condensate or product to roll off cover back into kettle.
 - d. Remove cover, ensuring that any remaining hot condensate or product does not drip on operator, floor or work surfaces.
 - e. Place cover on safe, flat, sanitary, out-of-the-way surface, or return to kettle.
2. Basket Insert
- An optional kettle basket insert set can assist in cooking water-boiled products including eggs, potatoes, vegetables, shell fish, pasta and rice. The nylon mesh liner must be used for products smaller than the basket mesh size, (approximately 1/4", 6mm). This includes rice and small pasta shapes. Tips for use:
- a. Allow for displacement of the three baskets and product. This may mean only half filling the kettle. Test baskets and product displacement with the kettle off, and with cold water in the kettle.
 - b. Load baskets on a level, stable work surface.
 - c. Lift loaded baskets with both hands. Get help from another person if the basket is too heavy for safe handling.
 - d. Slowly lower product into kettle and securely hook basket to the "Y" frame.
 - e. When removing baskets with cooked product, lift straight up, ensuring basket bottoms clear the kettle rim and pouring lip. Wear protective oven mitts and protective apron.
 - f. Allow hot water to fully drain from product before moving basket away from the kettle. Do not rest baskets on kettle rim or pouring lip. If baskets are too heavy for individual to lift and safely move, get help. Remove product immediately from basket into another container, being sure to avoid contact with hot product and hot basket or...
 - g. Place baskets with food on a stable, flat surface, inside a solid steamer or bake pan, to catch any remaining hot water draining from product.

Sequence of Operation

The following “action-reaction” outline is provided to help understand how the kettle works.

When the operator starts up the kettle by turning the operating thermostat dial from “OFF” to a desired setting, the thermostat switch closes. This lights up the heating indicator light and causes the contactors to close, allowing power to flow to heating elements.

When the temperature of the steam jacket reaches the value corresponding to the dial setting, the thermostat switch opens. This turns off the heating indicator light and causes the contactors to open, stopping the power to the heaters.

As soon as the thermostat senses that the kettle is cooking below the set point, the thermostat switch closes, the heating indicator light comes on, the contactors close, and the heaters come on again. On-off cycling continues, keeping the kettle at the set temperature.

This is why the heating indicator light cycles on and off during normal operation. Every time the kettle is tilted, the tilt cut-off switch interrupts the power supply to the heaters, so that the heating elements will not operate while not submerged in the jacket water.

If steam pressure greater than 50 PSI is generated in the jacket, the safety valve will open and relieve the excess pressure.

If the jacket water level gets too low before the heating elements overheat, the high-limit control will open and shut off power to the elements until the kettle cools.

Setting the operating thermostat dial to “OFF” shuts down all control and heating circuits.

Cleaning

WARNING

KEEP WATER AND SOLUTIONS OUT OF CONTROLS AND ELECTRICAL EQUIPMENT. DO NOT USE A HIGH PRESSURE HOSE TO CLEAN THE CONTROL CONSOLE, ELECTRICAL CONNECTIONS, ETC.

CAUTION

NEVER LEAVE A CHLORINE SANITIZER IN CONTACT WITH STAINLESS STEEL SURFACES FOR LONGER THAN 30 MINUTES. LONGER CONTACT CAN CAUSE CORROSION.

CAUTION

MOST CLEANERS ARE HARMFUL TO THE SKIN, EYES, MUCOUS MEMBRANES AND CLOTHING. PRECAUTIONS SHOULD BE TAKEN TO WEAR RUBBER GLOVES, GOGGLES OR FACE SHIELD AND PROTECTIVE CLOTHING. CAREFULLY READ THE WARNINGS AND FOLLOW LABEL DIRECTIONS.



Use a brush, sponge, cloth, plastic or rubber scraper, or plastic wool to clean.



Don't use metal implements or steel wool when cleaning.

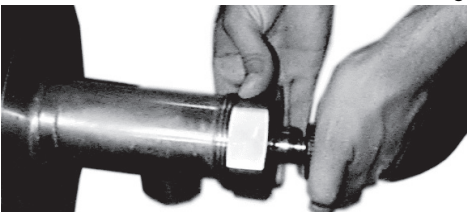

A. Suggested Cleaning Supplies

1. A high quality detergent and sanitizer, or a combination cleaning-sanitizing agent.
2. Kettle brushes in good condition.
3. Spray Degreaser.
4. De-limer/De-scaler.
5. A high quality stainless steel cleaner.

B. Precautions

Before any cleaning operation, shut off the kettle by turning the thermostat dial to "OFF", and shut off all electric power to the unit at a remote switch, such as the circuit breaker.

C. Procedure

1. Clean food contact surfaces as soon as possible after use, preferably while the kettle is still warm. If the unit is in continuous use, clean and sanitize inside and outside at least once every 12 hours.
2. Scrape and flush out large amounts of food residues. Be careful not to scratch the kettle with metal implements. Close the draw-off.
3. Prepare a solution of the detergent/cleaning compound as instructed by the supplier. Clean the unit thoroughly. A cloth moistened with cleaning solution can be used to clean controls, housing, electrical conduit, etc.
4. Rinse the kettle thoroughly with hot water. Then drain completely.
5. Disassemble the tangent draw-off valve. Clean the draw-off port and each valve part with a brush.
6. Rinse the kettle and draw-off valve parts thoroughly with hot water, then drain completely.
7. When you reassemble the draw-off valve, **HAND-TIGHTEN** the nut which holds it in place.
8. As part of the daily cleaning program, clean soiled external and internal surfaces. Remember to check the sides of the unit and control housing.
9. To remove burned-on foods, use a brush, sponge, cloth, plastic or rubber scraper, or plastic wool along with the cleaning solution. To reduce effort required in washing, let the detergent solution sit in the kettle for a few minutes and soak into the residue. Do NOT use abrasive materials or metal tools that might scratch the surface. Scratches make the surface harder to clean and provide places for bacteria to grow. Do not use steel wool, which will leave particles in the surface and cause eventual corrosion and pitting.
10. The outside of the unit may be polished with a recognized stainless steel cleaner.

Cleaning

CAUTION
NEVER LEAVE A CHLORINE SANITIZER
IN CONTACT WITH STAINLESS STEEL
SURFACES FOR LONGER THAN 30
MINUTES. LONGER CONTACT CAN
CAUSE CORROSION.

11. When the equipment needs to be sanitized, use a sanitizing solution equivalent to one that supplies 200 parts per million chlorine. Obtain advice on the best sanitizing agent from your supplier of sanitizing products. Following the suppliers instructions, apply the sanitizing agent after the unit has been cleaned and drained. Rinse off the sanitizer thoroughly.
12. It is recommended that each piece of equipment be sanitized just before use.
13. If there is difficulty removing mineral deposits or a film left by hard water or food residues, clean the kettle thoroughly and then use a deliming agent, in accordance with the manufacturer's directions. Rinse and drain the unit before further use.
14. If cleaning problems persist, contact your cleaning product supplier for assistance. The supplier has a trained technical staff with laboratory facilities to serve you.

Maintenance

WARNING

WHEN TESTING, AVOID ANY EXPOSURE TO THE STEAM BLOWING OUT OF THE SAFETY VALVE. DIRECT CONTACT COULD RESULT IN SEVERE BURNS.

WARNING

DISCONNECT ELECTRICAL POWER FROM THE UNIT BEFORE ATTEMPTING TO GREASE THE TRUNNION BEARINGS.

WARNING

TO AVOID INJURY, READ AND FOLLOW ALL PRECAUTIONS STATED ON THE LABEL OF THE WATER TREATMENT COMPOUND.

WARNING

ELECTRIC POWER ALWAYS SHOULD BE SHUT OFF BEFORE WORK IS DONE ON INTERNAL COMPONENTS.

CAUTION

BEFORE YOU HEAT THE KETTLE AGAIN FOR ANY PURPOSE, TURN THE ELBOW BACK CLOCKWISE UNTIL THE OPENING FACES DOWNWARD.



Make sure that the open end of the elbow on the pressure relief valve is directed downward.

The pressure gauge should show a vacuum of 20 to 30 inches when the kettle is cold.

NOTICE: Contact an authorized representative when repairs are required.

A Maintenance & Service Log is provided at the back of this manual. Each time maintenance is performed on your kettle, enter the date on which the work was done, what was done, and who did it. Keep this manual on file and available for operators to use. Periodic inspection will minimize equipment down time and increase the efficiency of operation. The following points should be checked:

1. Check the pressure/vacuum gauge everyday. The gauge should show a vacuum of 20 to 30 inches mercury (Hg), when the kettle is cold. If it does not, see “Jacket Vacuum” on page 14.
2. Also check the jacket water level every day. It should be between the markers on the gauge glass. If the level is low, see “Jacket Filling and Water Treatment” on page 14.
3. Test the safety valve at least twice each month. Test the valve with the kettle operating at 15 psi (105 kPa), by holding the test lever for at least 5 seconds. Then release the lever and let the valve snap shut. If the lever does not activate, or there is no evidence of discharge, or the valve leaks, stop using the kettle and contact a qualified service representative.
4. Keep electrical wiring and connections in good condition.
5. Keep the inside of the control console clean and dry.
6. **Jacket Vacuum/Removing Air from Jacket**

When the kettle is cold, a positive pressure reading on the pressure/vacuum gauge or a reading near zero indicates that there is air in the jacket. Air in the jacket acts as an insulator, and slows kettle heating.

To remove air:

- a. Start the unit. (Be sure there is water or product in the kettle when heating).
- b. When the pressure/vacuum gauge reaches a positive pressure reading of 5 PSI, release the trapped air and steam by pulling up or out on the safety valve lever or ring for about 1 second. Repeat this step, then let the pull ring or valve lever snap back into the closed position.

7. Jacket Filling and Water Treatment

The jacket was charged at the factory with the proper amount of treated water. You may need to restore this water, either because it was lost as venting steam or by draining.

- a. If you are replacing water lost as steam, use distilled water. If you are replacing treated water that ran out of the jacket, prepare more treated water as directed in “Water Treatment Procedure.”
- b. Allow the kettle to cool. Turn the elbow on the safety valve counterclockwise (to avoid thread damage) until the opening of the elbow faces upward.
- c. Open the safety valve and pour the water or treated water in at the elbow until the water level rises to a point between the marks on the gauge glass.

Maintenance

CAUTION
KEEP GREASE AWAY FROM ELECTRICAL PARTS LOCATED NEAR THE GEARS.

WARNING
TO AVOID INJURY, READ AND FOLLOW ALL PRECAUTIONS STATED ON THE LABEL OF THE WATER TREATMENT COMPOUND.

CAUTION
BEFORE YOU HEAT THE KETTLE AGAIN FOR ANY PURPOSE, TURN THE ELBOW BACK CLOCKWISE UNTIL THE OPENING FACES DOWNWARD.

WARNING
ELECTRIC POWER ALWAYS SHOULD BE SHUT OFF BEFORE WORK IS DONE ON INTERNAL COMPONENTS.

WARNING
DISCONNECT ELECTRICAL POWER FROM THE UNIT BEFORE ATTEMPTING TO GREASE THE TRUNNION BEARINGS.

CAUTION
NEVER LEAVE A CHLORINE SANITIZER IN CONTACT WITH STAINLESS STEEL SURFACES FOR LONGER THAN 30 MINUTES. LONGER CONTACT CAN CAUSE CORROSION.



- d. Air introduced to the jacket during filling must be removed to obtain efficient heating. See “Jacket Vacuum.”

8. Water Treatment Procedure

- a. Obtain water treatment compound and a pH test kit from your authorized parts distributor.
- b. Fill a mixing container with the measured amount of water required. (See table). Distilled water is recommended.

Kettle Model	Jacket Capacity
DEE/4-20	3-1/4 Gallons (12.3 liters)
DEE/4-40	4-1/2 Gallons (17.0 liters)
DEE/4-60	5 Gallons (18.9 liters)

- c. Hang a strip of pH test paper on the rim of the container, with about 1 inch of the strip below the surface of the water.
- d. Measure the water treatment compound. One way to do this is to add the compound from a measuring cup.
- e. Stir the water continuously, while you slowly add treatment compound, until the water has a pH between 10.5 and 11.5. Judge the pH by frequently comparing the test strip color with the color chart provided in the test kit. If you are color blind use an electroanalytical instrument to measure the pH level or have a person who is not color blind read the test strip color level.
- f. As you add water to the jacket, check water level to ensure that it is between minimum and maximum marks on gauge. Stop adding water when it reaches the maximum marker on the gauge.
- g. Record the exact amounts of water and treatment compound needed. These amounts may be used again, if the same water sources and compound are used. However, it is best to check the pH each time treated water is prepared.

- 9. **Component Replacement** Service Personnel should check the unit at least once a year. This periodic maintenance should include inspecting electrical wires and connections, and cleaning the inside of the control console.

At least twice a year, grease the two trunnion bearings and worm gear. We recommends the use of number two grade LGI lithium grease. Add grease through the zerk fittings on the gear hosing until the grease flows out of the bearings around the trunnion shaft. Also, add grease in the gear to cover arc that is in contact with the worm gear. Clean up excess grease.

Troubleshooting

Your kettle is designed to operate smoothly and efficiently if properly maintained. However, the following is a list of checks to make in the event of a problem. Wiring diagrams are furnished inside the service panel. X indicates items which must be performed by an authorized technician. **USE OF ANY REPLACEMENT PARTS OTHER THAN THOSE SUPPLIED BY THE MANUFACTURER OR AN AUTHORIZED DISTRIBUTOR CAN CAUSE INJURY TO THE OPERATOR AND DAMAGE TO THE EQUIPMENT AND WILL VOID ALL WARRANTIES.**

SYMPTOM	WHO	WHAT TO CHECK
Kettle will not heat and heating indicator will not come on.	User	a. Electric power supply to the unit. b. Water level in jacket.
	Authorized Service Rep Only	c. Control circuit fuses. Replace a blown fuse only with a fuse of the same AMP rating. X d. For loose or broken wires. X e. Tilt cut-off switch. X f. That pressure switch is open. X g. Operation of variable thermostat. X h. Low water cutoff. X
Kettle will not heat but heating indicator comes on.	User	a. For air in the jacket. See "Jacket Vacuum" in the "Maintenance" section of this manual.
	Authorized Service Rep Only	b. Contactor. X c. Heater elements with ohmmeter for ground short or open element. If element is defective, call Service. X
Kettle continues heating after it reaches the desired temperature.	User	a. Thermostat dial setting.
	Authorized Service Rep Only	b. Thermostat circuit for short. X c. Thermostat operation. The thermostat should click when the dial is rotated to settings above and below the temperature of the kettle. X d. Contactor, to determine whether it is energized or stuck. X
Kettle stops heating before it reaches the desired temperature.	User	a. Thermostat dial setting.
	Authorized Service Rep Only	b. Thermostat calibration. X c. Thermostat operation. The thermostat should click when the dial is rotated above and below the setting for the temperature of the kettle. X
Kettle heats slowly.	User	a. For air in the jacket. See "Jacket Vacuum" in the "Maintenance" section of this manual.
	Authorized Service Rep Only	b. Heater elements with ohmmeter for ground short or open element. If an element is defective, call service. X c. Voltage of main power source. X
Safety valve pops.	User	a. For air in the jacket. See "Jacket Vacuum" in the "Maintenance" section of this manual. b. Whether kettle was being heated empty when valve popped.
	Authorized Service Rep Only	c. Pressure switch setting. X d. Thermostat operation. Thermostat should click when the dial is rotated above and below the setting for the temperature of the kettle. X e. Safety valve. If the valve pops at pressures below 24 PSI, replace it. X f. Contactor, to determine whether it is de-energized. X

Troubleshooting

SYMPTOM	WHO	WHAT TO CHECK
Safety valve leaks a small amount of steam when the kettle is operating.	User	a. For contamination that prevents seating of valve. With full pressure in the jacket, pull the lever all the way briefly to blow the valve clean, then let the lever snap back to seat the valve.
	Authorized Service Rep Only	a. Safety valve for defects. Replace any defective valve with an identical valve. X
Kettle is hard to tilt.	User	a. For air in the jacket. See “Jacket Vacuum” in the “Maintenance” section of this manual.
	Authorized Service Rep Only	a. Tilting gear and worm for contamination and for proper alignment and lubrication. X

Parts List

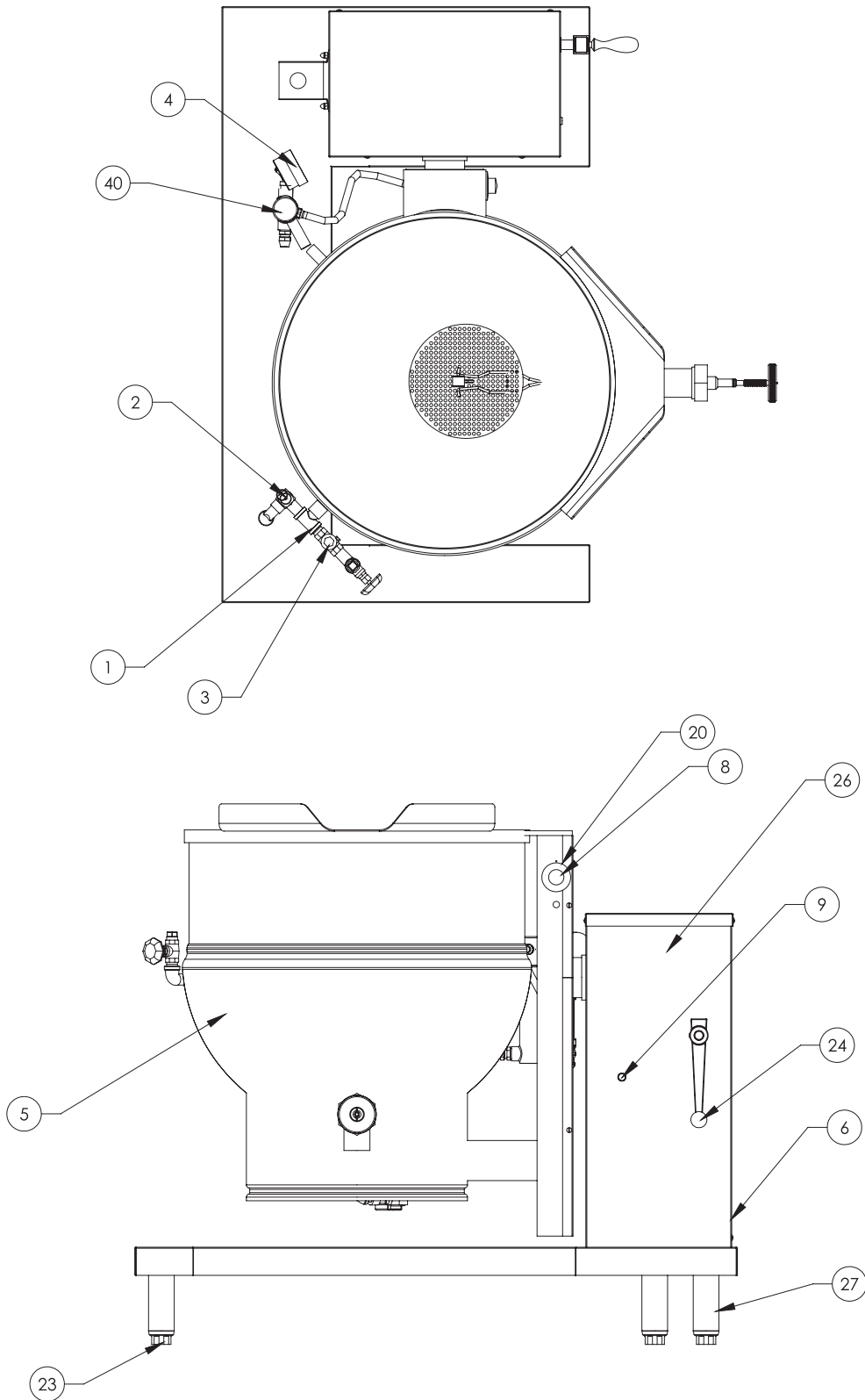

Parts List

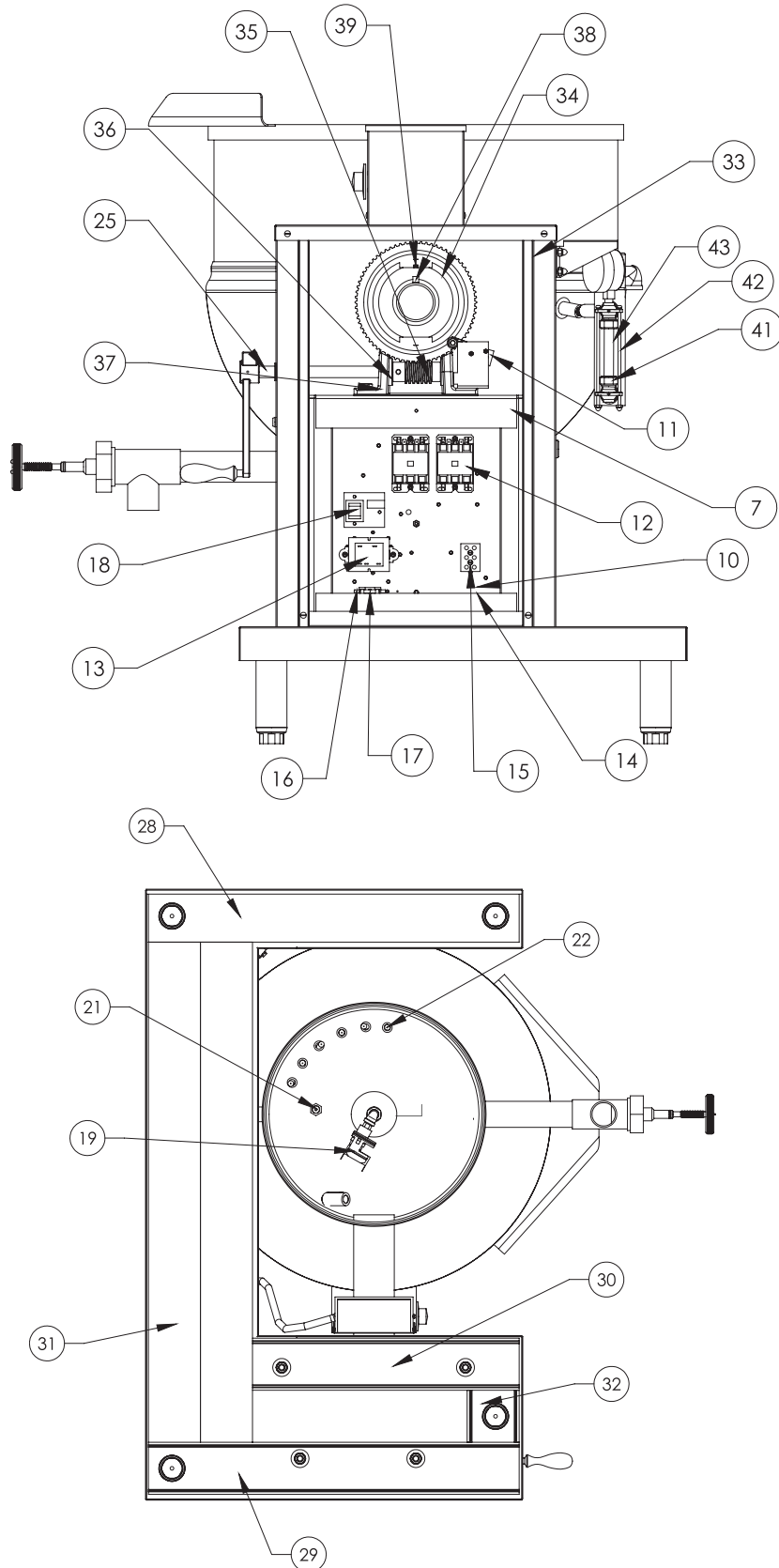

Parts List

To order parts, contact your Authorized Service Agent. Supply the model designation, serial number, part description, part number, quantity, and when applicable, voltage and phase.

KEY	DESCRIPTION	PART NO.
1	WATER FILL ASSEMBLY	097007
2	SAFETY VALVE	097005
3	CHECK VALVE	004187
4	PRESSURE GAUGE	084208
5	KBS AND TRUNNION, NO TDO 20 KBS AND TRUNNION, NO TDO 40 KBS AND TRUNNION, NO TDO 60 KBS AND TRUNNION, TDO-2 20 KBS AND TRUNNION, TDO-2 40 KBS AND TRUNNION, TDO-2 60	153236 153250 153256 153241 153251 153257
6	STAND AND HOUSING ASSEMBLY 20 STAND AND HOUSING ASSEMBLY 40, 60	140842 147855
7	PEDESTAL WELDMENT	138107
8	KNOB THERMOSTAT	012314
9	LIGHT, RED	116383
10	ELECTRICAL MOUNT ASSEMBLY	138123
11	TILT SWITCH	002982
12	CONTACTOR	148102
13	TRANSFORMER, 208/240V/24V 40VA TRANSFORMER, 480V/24V 40VA	137441 137694
14	GROUND TERMINAL	129714
15	TERMINAL BLOCK	003888
16	FUSE HOLDER	077854
17	FUSE, 3 AMP	077853
18	WATER LEVEL BOARD	122192
19	PRESSURE SWITCH	096963
20	THERMOSTAT	009730
21	WATER LEVEL PROBE	070178
22	ELEMENT, 208V 3.6 KW ELEMENT, 480V 4 KW ELEMENT, 208V 9.95 KW ELEMENT, 240V 8 KW ELEMENT, 480V 8 KW	011094 011088 005977 005974 005980
23	FOOT, ADJUSTABLE BULLET FOOT, FLANGED	013275 096569
24	HANDLE, CRANK	013617

KEY	DESCRIPTION	PART NO.
25	SHAFT, HANDWHEEL	013624
26	STAND CLADDING 20 STAND CLADDING 40, 60	140424 139056
27	LEG TUBE 20, 40, 60 LEG TUBE 40, 60	001469 147506
28	LEFT FRAME SUPPORT 20 LEFT FRAME SUPPORT 40, 60	137951 146999
29	RIGHT FRAME SUPPORT 20, 40, 60	137953
30	INNER FRAME SUPPORT 20, 40, 60	137954
31	REAR FRAME SUPPORT 20 REAR FRAME SUPPORT 40, 60	140422 146998
32	SHORT FRAME SUPPORT 20, 40, 60	137955
33	PEDESTAL CLADDING ASSEMBLY	138112
34	GEAR BORE	013609
35	WORM GEAR	012026
36	BEARING	009765
37	BEARING HOUSING	009762
38	KEY 3/8"	001474
39	SET SCREW	012060
40	WATER LEVEL ASSEMBLY	065198
41	FITTINGS, SIGHT GLASS ASSEMBLY	002845
42	GUARD, GLASS ROD GAUGE	002981
43	TUBE, WATER LEVEL	008742
44	ELBOW, F 90 DEG 1/2 NPT X 1/2" TUBE	055634
45	BUSHING, REDUCING 1/4" X 1/8" NPT	074872
46	ELECTRODE, WATER LEVEL	002170
x	COVER, BOTTOM 20	003333
x	COVER, BOTTOM 40, 60	003334
x	COVER, SIDE PEDESTAL	001464
x	COVER, TOP PEDESTAL	138114
x	COVER, LOWER TRUNNION SUPPORT ARM	116308
x	COVER, UPPER TRUNNION SUPPORT ARM	116305
x	OVERLAY OPERATING INSTRUCTIONS	137803
x	HARNESS, WIRE	148544
x	HARNESS, HIGH VOLTAGE	149942
x	HARNESS, CONTROL	149943

x- Item not depicted/called out in drawing

Wiring Diagram

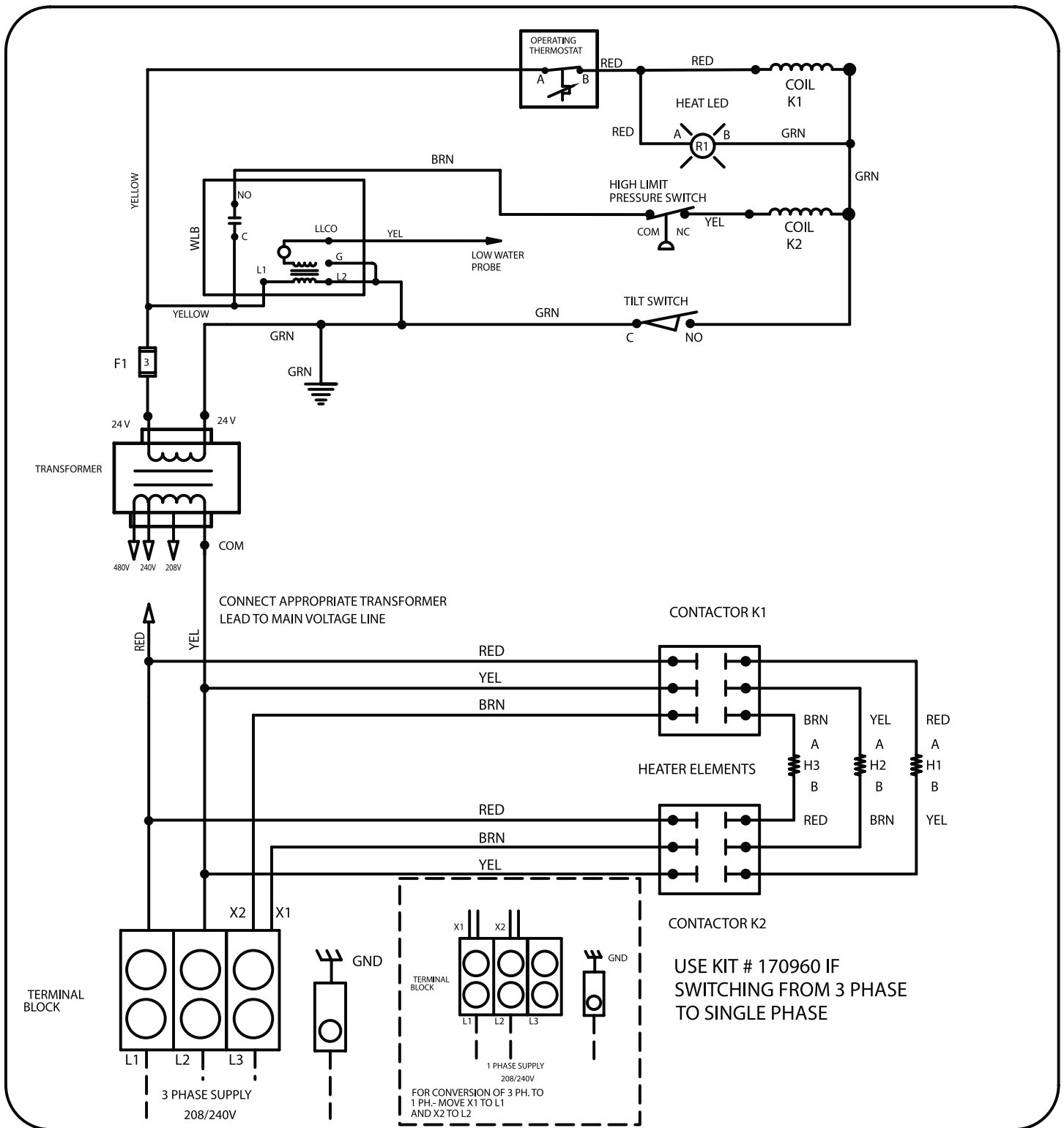



A **DOVER** COMPANY

1055 Mendell Davis Drive • Jackson MS 39272
888-994-7636 • 601-372-3903 • Fax 888-864-7636
unifiedbrands.net