

# INTEK®

## User's Manual

### XSG-5 Model Series

**FOR YOUR SAFETY:**

Do not store or use gasoline or other flammable liquids and vapors in the vicinity of this appliance.

**POST IN A PROMINENT LOCATION:**

Instructions to be followed in the event user smells gas. This information shall be obtained by consulting your local gas supplier. Ensure all users of this equipment understand the instructions.

**WARNING:**

Improper installation, adjustment, alteration, service, or maintenance can cause property damage, injury, or death. Read the installation, operating, and maintenance instructions thoroughly before installing and servicing this equipment.



**For Service Call  
888-994-7636**

 unified brands™  
A DOVER COMPANY

1055 Mendell Davis Drive, Jackson MS 39272 | Phone 888-994-7636 | Fax 601-373-9587

PART NUMBER 158633 REV A (11/10)

<b>INSTALLATION</b>	
General Safety .....	3
Gas Leak Instructions .....	3
Operational Safety .....	3
Location & Placement .....	3
On a Stand .....	4
On a Stand with Casters .....	4
Double-Stack Assembly .....	4
Exhaust Hood Requirements .....	5
Gas Supply .....	5
Gas Supply Requirements .....	5
Installation of Gas Supply Lines.....	5
Testing Gas Supply Lines .....	6
Pressure Testing Gas Supply Lines .....	6
Electrical Connections.....	6
Water Connection .....	7
In-Field Modifications .....	7
High Limit Lockout .....	7
Burner Blower Information .....	8
Power Failure and Ignition Warnings .....	8
<b>OPERATION</b>	
Daily Preparation .....	9
Filling with Water .....	9
Initial Lighting and Preheating .....	9
Cooking .....	9
Shutdown and Cleaning .....	9
<b>GENERAL INFORMATION</b>	
Control Panel .....	10
Tips & Tricks .....	11
High Volume / A la Carte Cooking .....	11
<b>WARRANTY</b> .....	12

## General Safety

---

Please make sure each operator reads and understands this manual completely before operating the steamer. The owner and operator(s) must keep these instructions in an easily accessible location for reference and training.

Steam can cause serious injuries and equipment damage. Pay attention to the Operational Safety section, the warnings in this manual, and on the equipment.

## Gas Leak Instructions

---

### **DANGER**

#### **GAS LEAKS ARE FIRE AND EXPLOSION HAZARDS. INJURY, DEATH AND PROPERTY DAMAGE WILL RESULT.**

If anyone smells gas, or suspects a gas leak, immediately refer to the posted gas leak instructions. The posted instructions are provided by the local gas supplier and supersede any other instructions.

Observe the following precautions in addition to the posted instructions:

- Do NOT light or start any appliance.
- Do NOT touch any electrical switch.
- Do NOT use any phone in the building.
- Immediately call the gas supplier from a phone away from the building.
- Follow the gas supplier's instructions.
- If the gas supplier cannot be reached, call the fire department.

## Operational Safety

---

- Do not store anything on top of the steamer.
- Keep the area around and under the steamer free and clear of combustible material.
- Do NOT obstruct the flow of combustion and ventilation air.

## Location and Placement

---

The Intek steamer is designed to be placed on a standard commercial kitchen countertop or on a stainless steel stand. For safe and efficient operation, observe the following criteria when selecting an operating location for this appliance.

- Installation must comply with all local fire and health codes.
- The location selected must be capable of supporting this appliance (the operating weight of a XSG-5 is 250lbs).
- Position this appliance so it will not tip or slide.
- The operating surface must be level enough to allow leveling of this appliance with its adjustable legs. This appliance **MUST** be level both front to back and side to side before operation.
- The location must include space for Operating and Service/Secondary Clearances and the

## Exhaust Hood.

- KEEP THE AREA FREE AND CLEAR OF COMBUSTIBLES.
- Proper air supply for ventilation and combustion is REQUIRED for and CRITICAL to safe, efficient operation of an XSG-5. Do NOT obstruct the flow of combustion and ventilation air.
- Make sure the air vents of the steamer are not blocked with or by anything.
- Allow for sufficient clearance if a “high heat source”, (e.g. a fryer) is located next to the steamer. Please contact Unified Brands at 888-994-7636 for recommendations.

## CLEARANCES

	Combustible Construction	Noncombustible Construction
Back	1”	-----
Right Side	1”	-----
Left Side	1”	-----

### A. On a Stand

If installing the unit onto a stand, bolt the unit(s) in place at the four locations on the bottom of the cooker, using the hardware provided with the stand. Level the unit(s) by adjusting the four legs on the stand.

### B. On a Stand With Casters

The installation shall be made with a connector that complies with the standard for connectors for moveable gas appliances; ANSI Z21.69 • CSA 6.16, and a quick-disconnect device that complies with the standard for quick-disconnect devices for use with gas fuel, ANSI Z21.41 • CSA 6.9.

Adequate means must be provided to limit the movement of the appliance without depending on the connector and the quick-disconnect device or its associated piping to limit the appliance movement.

The location where the restraining device may be attached to the appliance shall be in accordance with Intek specifications for the device.

### C. Double Stack Assembly

Refer to Figure 1 for the following instructions:

- 1) Remove exhaust deflectors (7) from both units.
- 2) Remove stainless steel shroud (1) from upper unit by removing (1) 10-24 x 3/4 screw and spacer.
- 3) Attach chimney brace (2) as shown, with tabs facing up, with existing (3) 10-24 x 1/2 screws.
- 4) Remove (2) remaining 10-24 x 1/2 screws at at bottom of outer chimney (3) of upper unit.
- 5) Attach inner chimney extension (4) as shown with (3) 10-24 x 1/2 screws.
- 6) Attach outer chimney extension (5) by aligning tabs to corresponding slots in

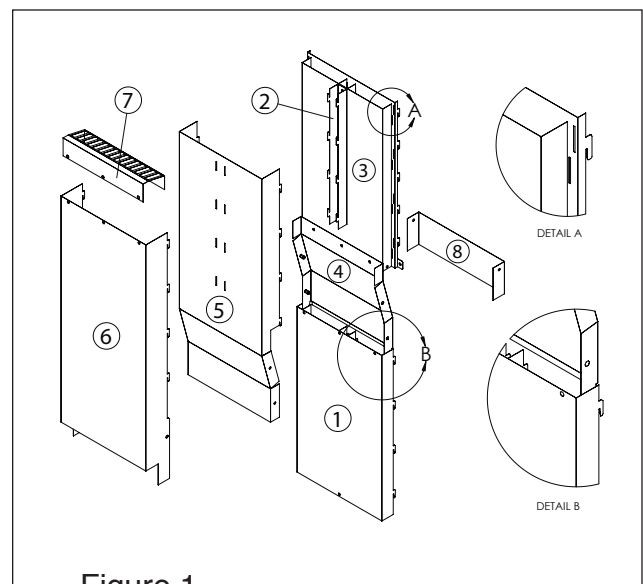

Figure 1

inner chimney, then slide over inner extension and down over tabs of chimney brace to lock in place. Use (4) 10-24 x  $\square$  screws to secure to inner extension.

7) Slide stainless steel outer shroud (6) tabs into exposed slots and down to lock in place.

8) Attach double-stack exhaust deflector (7) using (3) 10-24 x  $\square$  screws

9) Position stainless steel inner shroud (8) between steamers and attach to outer shroud with (2) 10-24 x  $\square$  screws.

## Exhaust Hood Requirements

---

Install and operate this gas appliance in a well ventilated area. Adequate air must be supplied to replenish air used for combustion. Installation must conform to local codes and/or with the National Fuel Gas Code, ANSI Z223.1/NFPA-54 (latest edition) or the National Gas and Propane Code CSA B149.1 as applicable.

Do not restrict the flow of air for combustion and ventilation. Do not obstruct the flue cover or control side vents after installation.

## Gas Supply

---

### DANGER

#### **GAS LEAKS ARE FIRE AND EXPLOSION HAZARDS. INJURY, DEATH AND PROPERTY DAMAGE WILL RESULT.**

If anyone smells gas, or suspects a gas leak, immediately refer to the posted gas leak instructions. The posted instructions are provided by the local gas supplier and supersede any other instructions.

Observe the following precautions in addition to the posted instructions:

- Do NOT light or start any appliance.
- Do NOT touch any electrical switch.
- Do NOT use any phone in the building.
- Immediately call the gas supplier from a phone away from the building.
- Follow the gas supplier's instructions.
- If the gas supplier cannot be reached, call the fire department.

### A. Gas Supply Requirements

- Gas supply type MUST match the type of gas shown on the rating plate.
- Gas supply pressure must NOT exceed 14" water column ( $\square$  PSI) and fall within the acceptable pressure range shown below when using  $\square$ " NPT line and a  $\square$ " NPT connection
- Gas supply pressure must be between 5" - 14" water column.
- If the gas supply pressure exceeds 14" water column, a pressure-regulating valve (pressure regulator) must be installed in the gas supply plumbing to reduce pressure to the steamer.

### B. Installation of the Gas Supply Lines

The Installer/owner is responsible for furnishing and installing gas supply lines, valves, regulators, and accessories.

When installing gas supply lines and accessories, observe the following:

- Use a non-hardening pipe thread sealant resistant to LP gas.
- The 1/2" NPT gas inlet is on the back of the steamer.
- Install main manual shut-off valve between gas supply and the steamer. This main manual shut-off valve is called the "Main Manual Gas Valve".
- Install a sediment trap (drip leg) in gas supply line.

## C. Testing Gas Supply Lines

- Test all pipe joints for leaks with soap and water solution.
- Check all connections for proper tightness.
- Remove the control side panel to inspect gas connections inside.
- Open the gas supply valves.
- Check all lines and connections for leaks, both inside and outside.
- All leaks must be corrected before operating the steamer.
- Replace the side panel and secure it before starting the steamer.

## D. Pressure Testing Gas Supply Lines

If any pressure testing is required, the steamer must be disconnected or isolated from the gas supply piping system during any pressure testing as follows:

- The appliance and its main manual shut-off valve must be **disconnected** from the gas supply piping system during any pressure testing of the system at test pressures in excess of 14" water column (1 psi or 3.45 kPa).
- The appliance must be isolated from the gas supply piping system by closing its main manual shut-off valve during any pressure testing of the gas supply piping system at test pressures in equal to or less than 14" water column (1 psi or 3.45 kPa).

## Electrical Connections

---

The Intek steam cooker has been designed, manufactured, and tested to meet or exceed the standards of safety set forth by Underwriter's Laboratories, Inc. If any of these instructions are not completely understood, or you have any doubt as to whether your supply receptacle is of the correct voltage, amperage, or is properly grounded, consult a qualified electrician or serviceman.

- A. Check the rating plate to make sure the steamer is compatible with the electric supply.
  - The rating plate is located on the control side panel.
  - The electrical diagram is located on the inside of the control side panel.
- B. The electrical supply must match all electrical and wiring requirements specified on the rating plate and the connection must be made in accordance with the following requirements:

The electrical power lines must be installed in accordance with:

- The National Electric Code, ANSI/NFPA No. 70 LATEST EDITION (USA).
  - Canadian Electric Code, CSA C22.2
  - Any other applicable national, state, or local laws, codes, and regulations.
- C. To reduce the risk of shock in the event of an electrical short circuit, this appliance must be grounded. The unit is equipped with a cord having a grounding wire and plug, which must be plugged into an outlet that is properly installed and grounded. Under no circumstances should the plug be cut or bent to fit a receptacle other than the one specified.

- D. Optionally, a permanent supply connection may be made using rigid or flexible conduit. Consult a qualified electrician or serviceman to ensure all wiring is performed to the electrical codes specified above.

## Water Connection

---

(Auto-Fill Models Only)

The appliance must be connected to a water supply not exceeding 60PSI. Use an NSF approved appliance hose with a ¾" garden hose type connection to connect from a spigot /shut-off valve to the steamer. It must also be installed with adequate backflow protection to comply with applicable Federal, State, and Local codes.

To operate, simply turn water supply ON and press the ON Pushbutton. The reservoir will automatically fill to the maximum operating level while the unit preheats to the Hold, Standby, or Cook temperature, depending on Model and settings.

### IMPORTANT

Always keep level sensing probes (located inside reservoir) clean. This will help insure proper working conditions.

## In-Field Modifications

---

Any in-field modifications made without written authorization from the Engineering Department will void your warranty. Please call 888-994-7636 to reach the Engineering Department.

## High Limit Lockout

---

The XSG-5 has a High Limit Lockout to protect the unit from overheating.

If the XSG-5 reaches the high limit temperature it will completely shut down and the steamer must be reset before cooking can continue.

- A. If the XSG-5 overheats and shuts completely down while cooking (no lights), open the door and verify that water is in the reservoir.

### **If there is no water in the reservoir:**

- 1) Wait for the steamer to cool
- 2) Clean the water level probes
- 3) Reset the High Limit Lockout (See B.)
- 4) Restart the steamer

### **If there is water in the reservoir at the operating level:**

- 1) Turn OFF the steamer and drain the water from reservoir
- 2) Wait for the steamer to cool
- 3) Clean the water level probes
- 4) Reset the High Limit Lockout (See B.)
- 5) Restart the steamer

*If the problem repeats, call the Service Department at 888-994-7636*

## B. To Reset the High Limit Lockout:

- 1) Open the cooking compartment door and wait for the steamer to cool.
- 2) After the steamer is cool, check that the Water Level Sensor Probes are clean.
- 3) Fill cooking compartment with 3 gallons of water.
- 4) Turn the unit OFF and then ON again.
- 5) If the High Limit Lockout repeats, call the Service Department at 888-994-7636.

## Burner Blower Information

---

The bearings in the burner blower are permanently lubricated and do not require any periodic maintenance.

## Power Failure and Ignition Warnings

---

### **DANGER**

**Do NOT attempt to operate an Intek XSG-5 during a power failure. DEATH, INJURY and EQUIPMENT DAMAGE can result.**

**During a power failure, turn the steamer OFF and close the Main Gas Shut-Off Valve.**

### **DANGER**

#### **DO NOT TRY TO LIGHT BURNER WITH A FLAME**

The XSG-5 has an electronic ignition system, which automatically lights the burner, senses flame and controls gas flow. This provides precise burner control, safe ignition and safe shutdown.

**DEATH, INJURY, and EQUIPMENT DAMAGE** may result from trying to light burners with a flame or from an improperly adjusted gas control and ignition system. Do not try to light the burner with a flame and do not alter the gas control adjustments.

If adjustment is required, contact the Service Department at 888-994-7636.

Unified Brands is in no way responsible for the operation or safety of this equipment if the controller, valve, igniter probe or any other gas system component is adjusted by anyone other than a qualified Intek authorized service representative.



## Daily Preparation

---

Preparing the XSG-5 for use each day requires very little time and effort. Simply fill the steamer with water and preheat.

### A. Filling with Water

At the beginning of each day, pour three gallons of ordinary tap water into the bottom of the cooker. Water usage will depend on what products you are cooking and the length of time the door is open. In most cases three gallons of water will last several hours or more. When the ADD WATER indicating light and buzzer come on, simply refill the unit with water and continue. If a shutdown occurred during cooking, the cycle will resume at the point it stopped. However, a time adjustment may be necessary due to the temperature of the water the unit was filled with.

### B. Initial Lighting and Preheating

For best results, the cooker should be preheated before starting the first cook cycle of the day. With the water reservoir full and the Main Gas Shut-Off Valve open, turn the OFF/ON switch to the ON position and set the timer to 15 minutes. When the cycle is complete, the unit will automatically switch to the STANDBY mode, at which time the cooker is ready for use.

**IMPORTANT:** IF GAS SUPPLY IS INTERRUPTED DURING OPERATION, A FIVE(5) MINUTE PERIOD OF COMPLETE SHUT-OFF OF GAS SUPPLY IS REQUIRED BEFORE RE-STARTING.

### C. Cooking

To begin cooking, place the food to be cooked into the steamer and set the timer to the desired cooking time. When the cycle is complete, the End of Cook Cycle Buzzer will sound and the cooker will automatically switch to STANDBY mode.

You can check the food at anytime during the cook cycle. Just open the door - check the food, and reclose the door. YOU DO NOT HAVE TO TURN THE UNIT OFF.

### D. Shutdown and Cleaning

At the end of each day the steamer should be drained and cleaned. First, turn the cooker off and allow a few minutes for it to cool down. Use caution when draining a warm or hot cooker. Clean with mild detergent, rinse and leave the door ajar.

## Control Panel

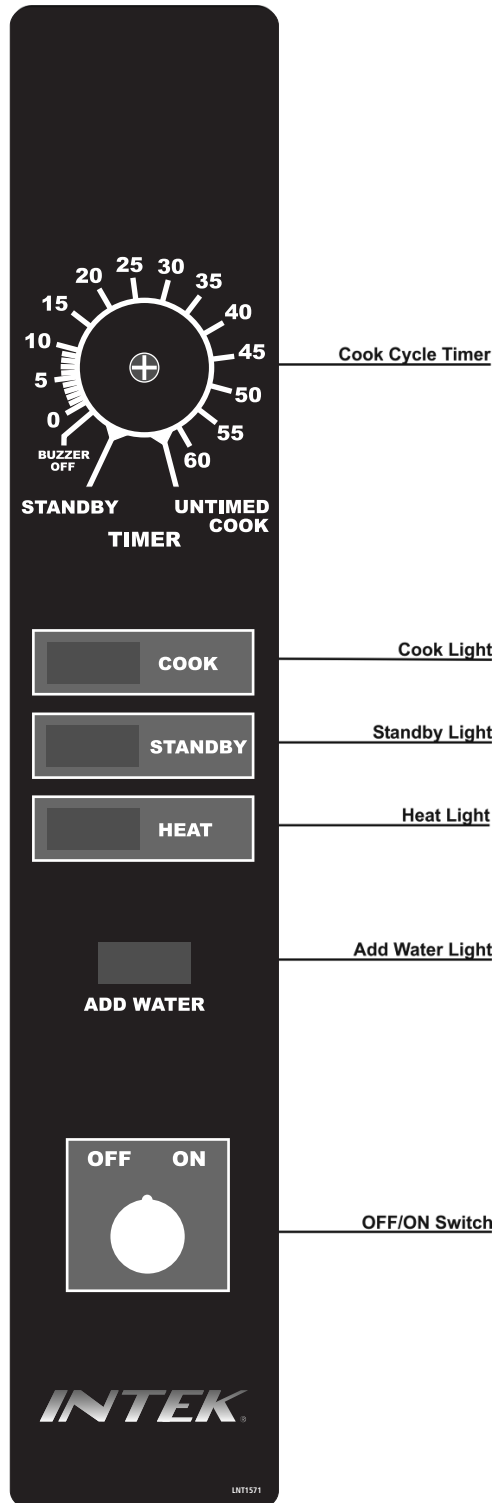

## Tips & Tricks

---

For faster cook times in the Intek steamer, try one or more of the following methods.

**DO NOT PUT LIDS OVER PRODUCTS.** This will double or sometimes triple cook times. The only products you may want to put lids on are soups, sauces, and anything desired crunchy.

**USE PERFORATED PANS WHENEVER POSSIBLE.** You can put a solid pan on the rack beneath the product cooking to catch drips. If you must use a solid pan, pour one cup of water in the pan per pound of product being cooked. This shortens cook times and helps cook more evenly.

Use of deeper solid pans will increase your cook times by 10-40%. The shallower the solid pan, the better. For example: Ten pounds of frozen loose corn will take less time if cooked in two 2.5" pans rather than one 4" pan.

## High Volume/A la Carte Cooking

---

**Frozen Vegetables:** In perforated pans, roughly a minute per pound and a minute per pan. For example: 15 lbs of corn in 3 perforated pans will take approximately 18 minutes.

**Dry Pasta:** Preheat water in 4" solid pan. Add pasta. Cook time is similar to stove top, but stirring is not necessary.

**Rice:** Do not cover. Institutional rice takes about 35 minutes and all others take about 25 minutes. Use 1.8 parts water to 1 part rice. For example: For 5 cups of rice you need 9 cups of water. The XSG-5 is a great rice cooker.

**Pre-cooked Breakfast Meat:** Pre-cooked sausages and bacon can be rethermalized by steaming the product until internal temperature reaches 165 °F (20-30 minutes).

**Scrambled Eggs:** Cover the bottom of a solid 4" pan with plastic wrap and fill with eggs. Cook until done, around 25 minutes. Do not stir. Invert the eggs into another solid 4" pan. Eggs will not stick because of the plastic lining, saving time with clean up.

**Frozen Pancakes:** Simply layer them in a perforated pan and steam for 6-10 minutes until their internal temperature reaches 150°F.

**Cornbread:** Use milk instead of water in your recipe and cook for 15 minutes or until a knife inserted comes out clean. Do not cover. It will be moist, but not soggy.

## **1 Year Parts & Labor Warranty**

Unified Brands (UB) warrants that your steam cooker will be free of defects in material and workmanship under normal use for a period of one (1) year from the date of shipment from the factory.

During the warranty period, UB agrees to repair or replace, at its option, F.O.B. factory, any part which proves to be defective due to defects in material or workmanship, provided the equipment has not been altered in any way, and has been properly installed, maintained, and operated in accordance with the instructions in the User's Manual.

During the warranty period, UB also agrees to pay any factory authorized equipment service agency (within the continental United States and Canada) for reasonable labor required to repair or replace parts due to defects in material or workmanship, provided the service agency has received advance approval from UB factory service to perform the repair or replacement. This warranty includes travel time not to exceed two hours and mileage not to exceed 50 miles (100 miles round trip), but does not include post start-up assistance or training, tightening of loose fittings or external electrical connections, minor adjustments, maintenance or cleaning. UB will not reimburse the expense of labor required to repair or replace parts after the one year warranty period.

Proper installation is the responsibility of the dealer, owner-user, or installing contractor and is not covered by this warranty. While UB products are built to comply with applicable standards for manufacturers, including Underwriter's Laboratories (UL) and the National Sanitation Foundation (NSF), it is the responsibility of the owner and installer to comply with any applicable local codes that may exist.

UB makes no other warranties or guarantees, whether expressed or implied, including any warranties of performance, merchantability, or fitness for any particular purpose. UB's liability on any claim of any kind, including negligence, with respect to the goods and services covered hereunder, shall in no case exceed the price of the goods and services, or parts thereof, which give rise to the claim. In no event shall UB be liable for special, incidental, or consequential damages, or damages in the nature of penalties.

This constitutes the entire warranty, which supersedes and excludes all other warranties, whether written, oral or implied.

***INTEK***®

***INTEK***®

***INTEK***®



1055 Mendell Davis Drive • Jackson MS 39272  
888-994-7636 • 601-372-3903 • Fax 888-864-7636  
[unifiedbrands.net](http://unifiedbrands.net)