

INTEK®

SERVICE MANUAL / PARTS LIST

MODEL XSG-5



1055 Mendell Davis Drive • Jackson MS 39272
888-994-7636 • 601-372-3903 • Fax 888-864-7636
unifiedbrands.net

TABLE OF CONTENTS

POWER FAILURE AND IGNITION WARNINGS	3
OPERATING SUMMARY	
Sequence of Operation (Manual Fill).....	4
Sequence of Operation (Auto Fill).....	5
In-Field Modifications.....	6
High Limit Lockout.....	6
CONTROL SIDE COMPONENTS	7
PLUMBING SIDE COMPONENTS	8
DOOR COMPONENTS	9
STANDARD WIRING DIAGRAM	10
STANDARD TROUBLESHOOTING	11
AUTO-FILL WIRING DIAGRAM	12
AUTO-FILL TROUBLESHOOTING	13
DOUBLE-STACK CHIMNEY KIT INSTALLATION	14-16
NORMAL OPERATING RANGE	17
COMPONENT AMP CHART	18
SERVICE BULLETIN #263	19-20
BURNER REPLACEMENT	21-26

POWER FAILURE AND IGNITION WARNINGS

DANGER

Do NOT attempt to operate a XSG-5 during a power failure. DEATH, INJURY and EQUIPMENT DAMAGE can result.

During a power failure, turn the steamer OFF and close the Main Gas Shut-Off Valve.

DANGER

DO NOT TRY TO LIGHT BURNER WITH A FLAME

The XSG-5 has an electronic ignition system, which automatically lights the burner, senses flame and controls gas flow. This provides precise burner control, safe ignition and safe shutdown.

DEATH, INJURY and EQUIPMENT DAMAGE may result from trying to light burners with a flame or from an improperly adjusted gas control and ignition system. Do not try to light the burner with a flame and do not alter the gas control adjustments.

If adjustment is required, contact the Unified Brands Service Department at 888-994-7636. Unified Brands is in no way responsible for the operation or safety of this equipment if the controller, valve, igniter probe or any other gas system component is adjusted by anyone other than a qualified authorized service representative.

OPERATING SUMMARY - SEQUENCE OF OPERATION

For Gas Model, Manual Filling

START-UP

- When the power cord is plugged in there is AC power to terminal 1 (HOT) and terminal 2 (Neutral) on the choke timer.
- When the ON/OFF switch is activated, terminal 3 on the choke timer is energized starting the choke timer sequence. The choke solenoid is energized for 16 seconds. The high limit is also energized sending power to the common terminal of the LLCO contacts on the Water Level Control. The water level board is also energized causing the H/L (High/Low) contacts on the Water Level Control board to switch.
- Manual filling of the steamer is now required. Once the water level in the steamer reaches the lower probe, the LLCO contacts switch sending power to the common terminal of the H/L contacts causing the add water light and buzzer to come on.
- When the steamer cavity is filled with enough water to hit the high probe, the H/L contacts switch and power is sent down to the heat circuitry.
- While that is occurring you are still timing the choke timer (**once the choke timer has run its sequence it can only be re-energized by turning the ON/OFF switch OFF and then back ON**). **Pre-filling the steamer cavity, before activating the ON/OFF switch is recommended on manual fill models.**
- If the pressure switch is closed, Control Relay 2 will energize sending power to the burner blower timer, energizing the burner blower.
- When the blower comes up to speed it pulls a vacuum closing VS-1 turning the Heat Lamp ON and energizing the ignition controller. The ignition controller performs a self-diagnostics on power up. After a pre-purge of 5 seconds, the main gas valve is energized and the Igniter commences to spark until a flame is detected or the Trial for Ignition period of 10 seconds expires. Once the flame is detected the spark is shut off and the main gas valve remains energized. Should the burner fail to light or flame is not detected during the first trial for ignition period, the gas valve is de-energized and the control starts the inter-purge sequence of 15 seconds before attempting another Trial for Ignition. The control will make two additional attempts and if unsuccessful will go into lock-out. Lockout Recovery is accomplished by turning the power switch to the OFF position. Waiting a minimum of 5 seconds, then return the power switch to the ON position.

THE TIMER

- In Standby Mode - Control Relay 1 is de-energized, the Internal Convection Fan Motor and the Cook Lamp are OFF and Standby Lamp is ON.
- In Timed Mode (timer turned to any timed sequence) or Untimed Cook Mode (full on), control relay 1 is energized turning on the Cook Lamp. The Internal Convection Fan is energized and Standby Lamp is OFF.
- Time Mode Continued- Timer will time down until the buzzer sounds. Turning the buzzer off will activate the Standby Mode unless the timer is reset to a Timed or Untimed Cook position.

ADD WATER LIGHT

- If the water level drops below the high probe, the heating circuit is de-energized and the Add Water Light and Buzzer will come ON.
- If the water level continues to drop below the low probe the unit will completely shut down.

HIGH LIMIT

- The High Limit uses a Type K thermocouple to monitor excessive heat in the combustion chamber. When a temperature exceeding 500°F is detected the control will shut down the heating circuit. The control has an auto reset function and will automatically reset when the detected temperature drops below the set point.

OPERATING SUMMARY - SEQUENCE OF OPERATION

For Gas Model, Auto Fill

START-UP

- When the power cord is plugged in there is AC power to terminal 1 (HOT) and terminal 2 (Neutral) on the choke timer.
- When the ON/OFF switch is activated, terminal 3 on the choke timer is energized starting the choke timer sequence. The choke solenoid is energized for 45 seconds. The high limit is also energized sending power to the common terminal on the LLCO contacts of the Water Level Control. The Water Level Control board is also energized causing the H/L (High/Low) contacts to switch energizing the Water Fill Valve.
- Once the water level in the steamer cavity reaches the low probe, the LLCO contacts switch sending power to the heating circuitry. Water will continue to fill passed the middle probe to the upper probe. When the water level reaches the upper probe the water valve is de-energized.
- When the water level drops below the upper and middle probe the water valve is re-energized and refills the steamer cavity to the top probe.
- If the water level drops below the low probe the LLCO contacts will switch shutting down the heating circuitry.
- While the steamer cavity is filling the choke timer is still timing (**once the choke timer has run its sequence it can only be re-energized by turning the ON/OFF switch OFF and then back ON**).
- If the pressure switch is closed, Control Relay 2 will energize sending power to the burner blower timer, energizing the burner blower.
- When the blower comes up to speed it pulls a vacuum closing VS-1 turning the Heat Lamp ON and energizing the ignition controller. The ignition controller performs a self-diagnostics on power up. After a pre-purge of 5 seconds, the main gas valve is energized and the Igniter commences to spark until a flame is detected or the Trial for Ignition period of 10 seconds expires. Once the flame is detected the spark is shut off and the main gas valve remains energized. Should the burner fail to light or flame is not detected during the first trial for ignition period, the gas valve is de-energized and the control starts the inter-purge sequence of 15 seconds before attempting another Trial for Ignition. The control will make two additional attempts and if unsuccessful will go into lock-out. Lockout Recovery is accomplished by turning the power switch to the OFF position. Waiting a minimum of 5 seconds, then return the power switch to the ON position.

THE TIMER

- In Standby Mode - Control Relay 1 is de-energized, the Internal Convection Fan Motor and the Cook Lamp are OFF and Standby Lamp is ON.
- In Time Mode – timer turned to any timed sequence or Untimed Cook Mode (full on); control relay 1 is energized turning on the cook lamp. The internal convection fan is energized and standby lamp is OFF.
- Time Mode Continued- Timer will time down until the buzzer sounds. Turning the buzzer off will activate the Standby Mode unless the timer is reset to a Timed or Untimed Cook position.

NO ADD WATER LIGHT

- The water level is controlled by the water level control board. The control will maintain the water level between the high and middle probe.

HIGH LIMIT

- The High Limit uses a Type K thermocouple to monitor excessive heat in the combustion chamber. When a temperature exceeding 500°F is detected the control will shut down the heating circuit. The control has an auto reset function and will automatically reset when the detected temperature drops below the set point.

OPERATING SUMMARY

With the water reservoir full and the Main Gas Shut-Off Valve open, turn the OFF/ON switch to the ON position and set the timer to 15 minutes. When the cycle is complete, the unit will automatically switch to the STANDBY mode, at which time the cooker is ready for use.

IMPORTANT: IF GAS SUPPLY IS INTERRUPTED DURING OPERATION, A FIVE (5) MINUTE PERIOD OF COMPLETE SHUT-OFF OF GAS SUPPLY IS REQUIRED BEFORE RE-STARTING.

In-Field Modifications ---

Any in-field modifications made without written authorization from the Unified Brands Engineering Department will void your warranty. Please call 888-994-7636 to reach the Engineering Department.

High Limit Lockout ---

The XSG-5 has a High Limit Lockout to protect the unit from overheating.

If the XSG-5 reaches the high limit temperature it will completely shut down and the Steamer must be reset before cooking can continue.

A. If the XSG-5 overheats and shuts completely down while cooking (no lights), open the door and verify that water is in the reservoir.

If there is no water in the reservoir:

- 1) Wait for the steamer to cool
- 2) Clean the water level probes
- 3) Reset the High Limit Lockout (See B.)
- 4) Restart the steamer

If there is water in the reservoir at the operating level:

- 1) Turn OFF the steamer and drain the water from reservoir
- 2) Wait for the steamer to cool
- 3) Clean the water level probes
- 4) Reset the High Limit Lockout (See B.)
- 5) Restart the steamer

- B. 1) Open the cooking compartment door and wait for the steamer to cool.
2) After the steamer is cool, check that the Water Level Sensor Probes are clean.
3) Fill cooking compartment with 3 gallons of water.
4) Turn the unit OFF and then ON again.
5) If the High Limit Lockout repeats, call the Service Department at 888-994-7636

XSG-5 CONTROL SIDE COMPONENTS

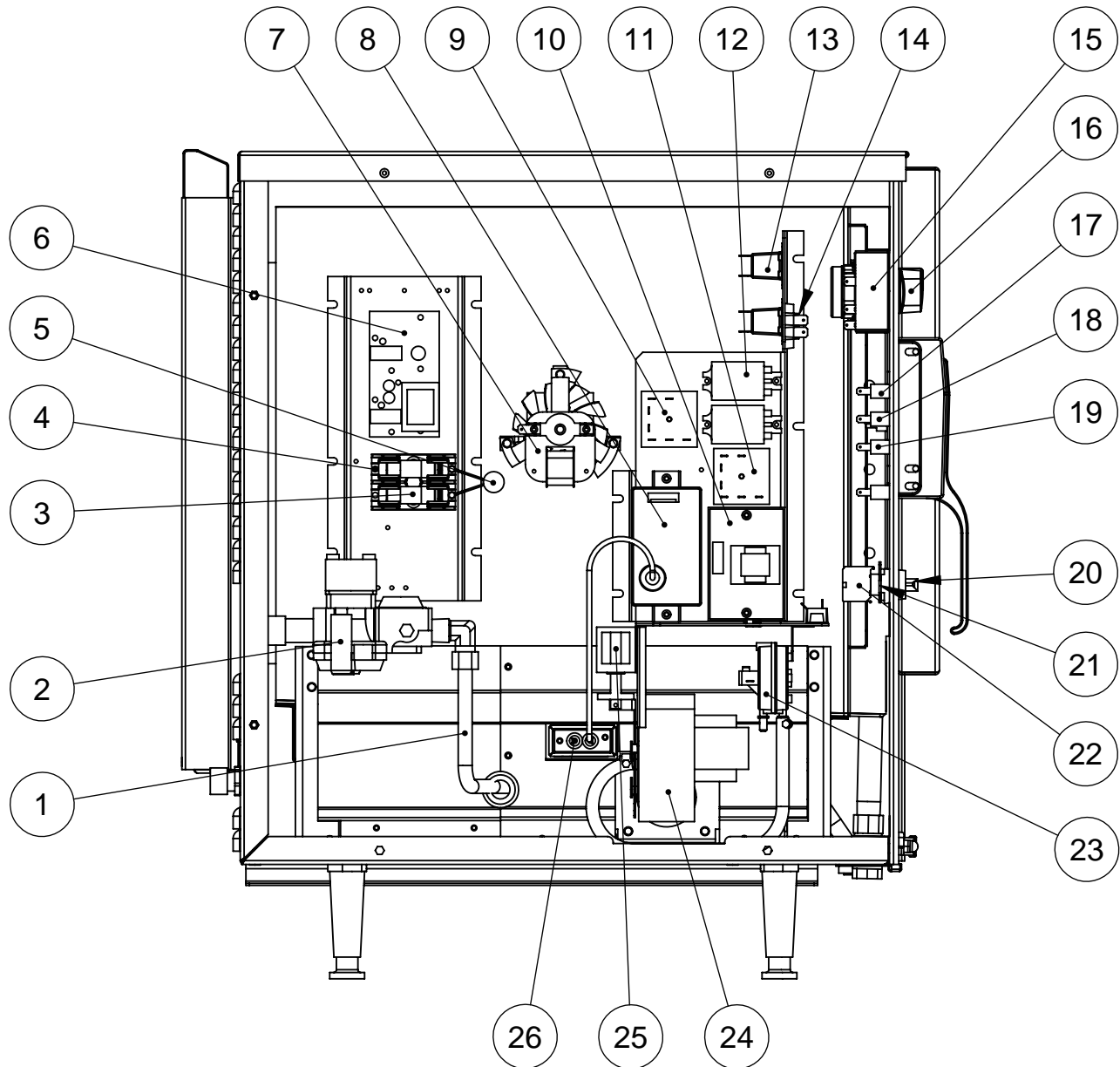

ITEM	PART #	DESCRIPTION	QTY.	ITEM	PART #	DESCRIPTION	QTY.
1	NT1561	14" SS FLEXIBLE GAS LINE	1	14	NT1624	TERMINAL BLOCK, 2 POSITION	1
2	NT1747	GAS REGULATOR AND VALVE (NG/LP)	1	15	NT1523	TIMER, 60 MINUTE, 120V	1
3	NT1073	FUSE, 5 AMP	2	16	H1178	KNOB	1
4	NT1074	FUSE BLOCK, 2-POLE	1	17	NT1557	LAMP, AMBER, 120V	1
5	NT1567	VARISTOR	1	18	NT1628	LAMP, BLUE, 120V	1
6	NT1829	WATER LEVEL CONTROL (INCLUDES PROBES)	1	19	NT1556	LAMP, RED, 120V	2
7	NT1559	FAN, CONVECTION, 120V	1	20	NT1565	ON/OFF SWITCH	1
8	NT1575	IGNITION CONTROL	1	21	NT1088	MOUNTING LATCH	1
9	NT1745	SOLID STATE TIMER, SOLENOID (INCLUDES NT1748 RESISTOR)	1	22	NT1090	CONTACT, ON SWITCH	1
10	NT1574	HIGH TEMP CONTROL	1	23	NT1612	VACCUUM SWITCH	1
11	NT1613	SOLID STATE TIMER, BLOWER MOTOR (INCLUDES NT1615 RESISTOR)	1	24	NT1606	BLOWER MOTOR	1
12	NT1720	CONTROL RELAYS, 120V	2	25	NT1746	SOLENOID	1
13	NT1568	BUZZERS, 120V	2	26	NT1578	IGNITOR/SENSOR PROBE	1

XSG-5 PLUMBING SIDE COMPONENTS (Shown with Auto-Fill Option)

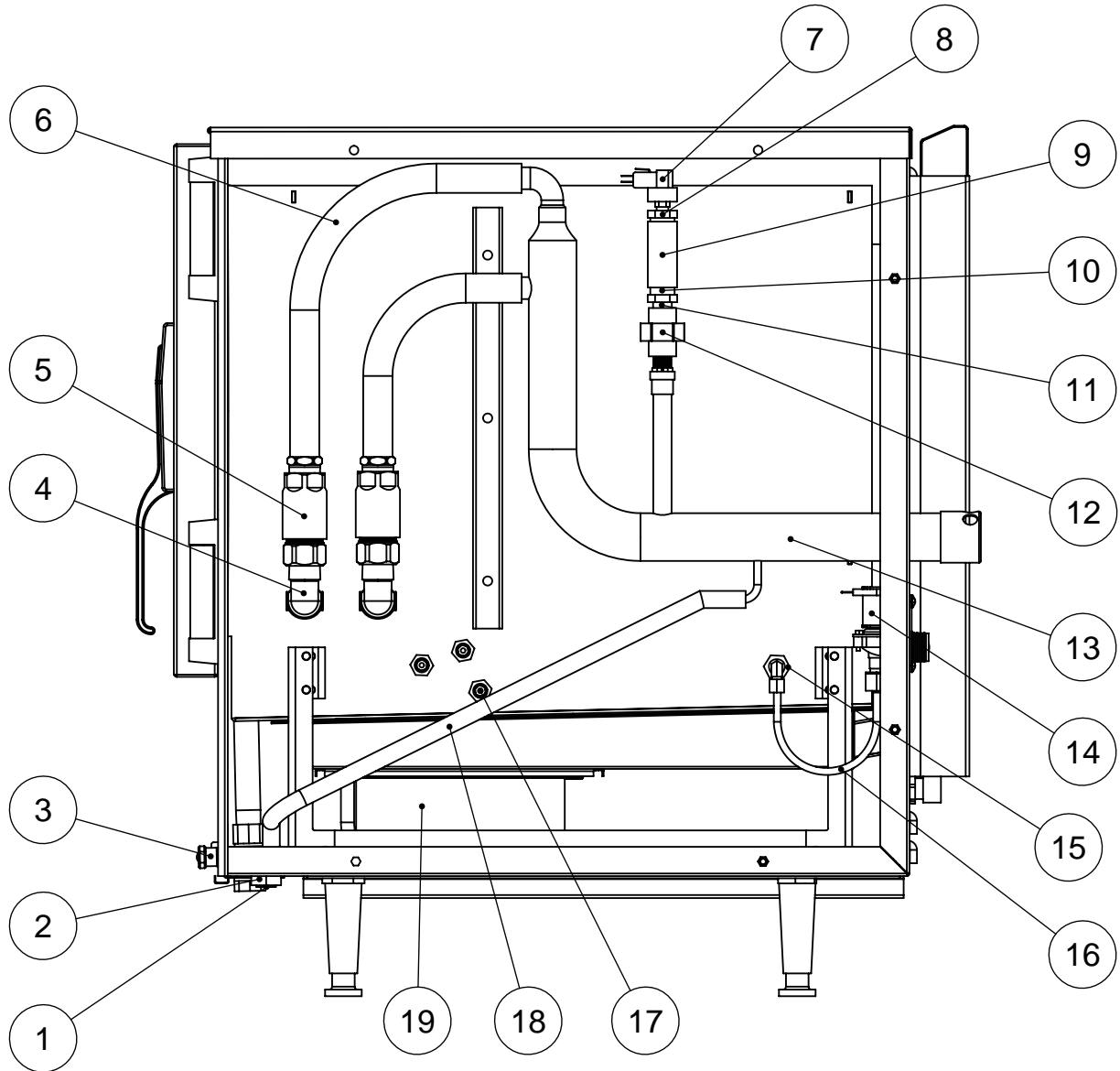

ITEM	PART #	DESCRIPTION	QTY.	ITEM	PART #	DESCRIPTION	QTY.
1	NT1555	3/4 MP x HB 90 DEG. FITTING	1	11	NT1140	3/8 BRASS NIPPLE	1
2	NT1138	3/8 NPT LOCKNUT	1	12	NT1139	3/8 NPT UNION	1
3	NT1127	1 1/2 BALL VALVE DRAIN	1	13	NT1278	MANIFOLD	1
4	NT1134	3/4 ELBOW	2	14	NT1721	AUTO-FILL VALVE	1
5	NT1502	CHECK VALVE ASSEMBLY	2	15	NT1474	90 ELBOW	1
6	NT1132	3/4 HOSE	1	16	NT1479	TEFLON TUBING	1
7	NT1091	PRESSURE SWITCH	1	17	NT1566	WATER LEVEL PROBES (INCLUDES CONTROLLER)	2
8	NT1202	1/2 x 1/8 BRASS REDUCER BUSHING	1	18	NT1203	5/16 HOSE	1
9	NT1200	BRASS TEE	1	19	G1562	INFRARED BURNER	1
10	NT1201	1/2 x 3/8 BRASS REDUCER BUSHING	1		NT1820	3RD WATER LEVEL PROBE (AUTO-FILL ONLY)	1

XSG-5 DOOR COMPONENTS

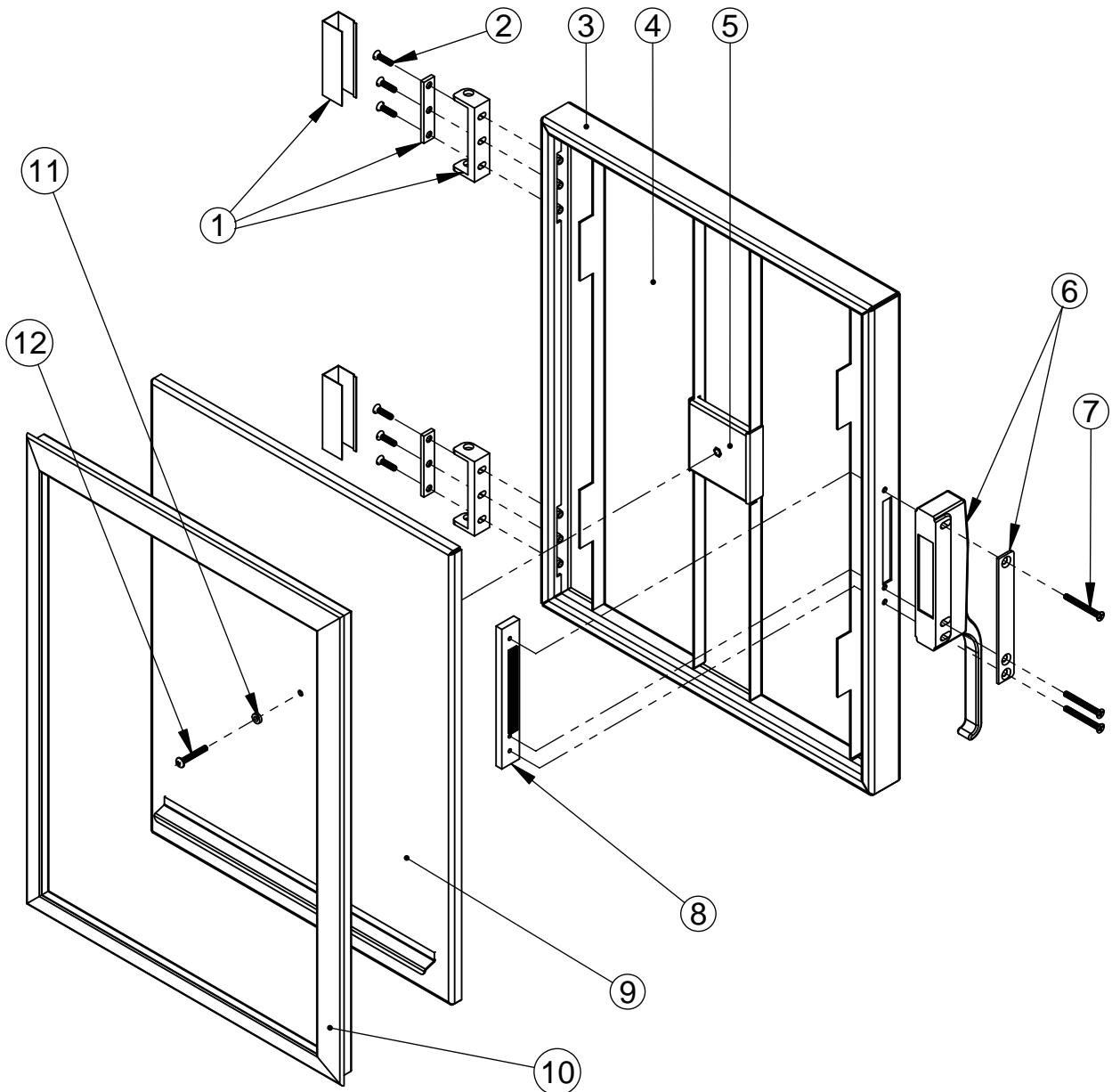

ITEM	PART #	DESCRIPTION	QTY.
1	NT1115	Door Hinge	2
2	NT1106	Screw, 10-24 x 3/4" SS FH Slotted	6
3	NT1511	Panel, Outer Door	1
4	NT1508	Bracket, Inner Door	2
5	NT1050	Bracket, Inner Door Mount	1
6	NT1144	Magnetic Door Latch	1
7	NT1545	Screw, 10-24 x 1 3/4" SS FH Phillips	3
8	NT1538	Nut Plate	1
9	NT1509	Panel, Inner Door w/M1236 welded on	1
10	NT1539	Door Seal	1
11	NT1179	Washer, Silicone #10	1
12	NT1161	Screw, 10-24 x 1 1/4" SS PHPS	1

Door Insulation (not shown): NT1729

XSG-5 STANDARD WIRING DIAGRAM

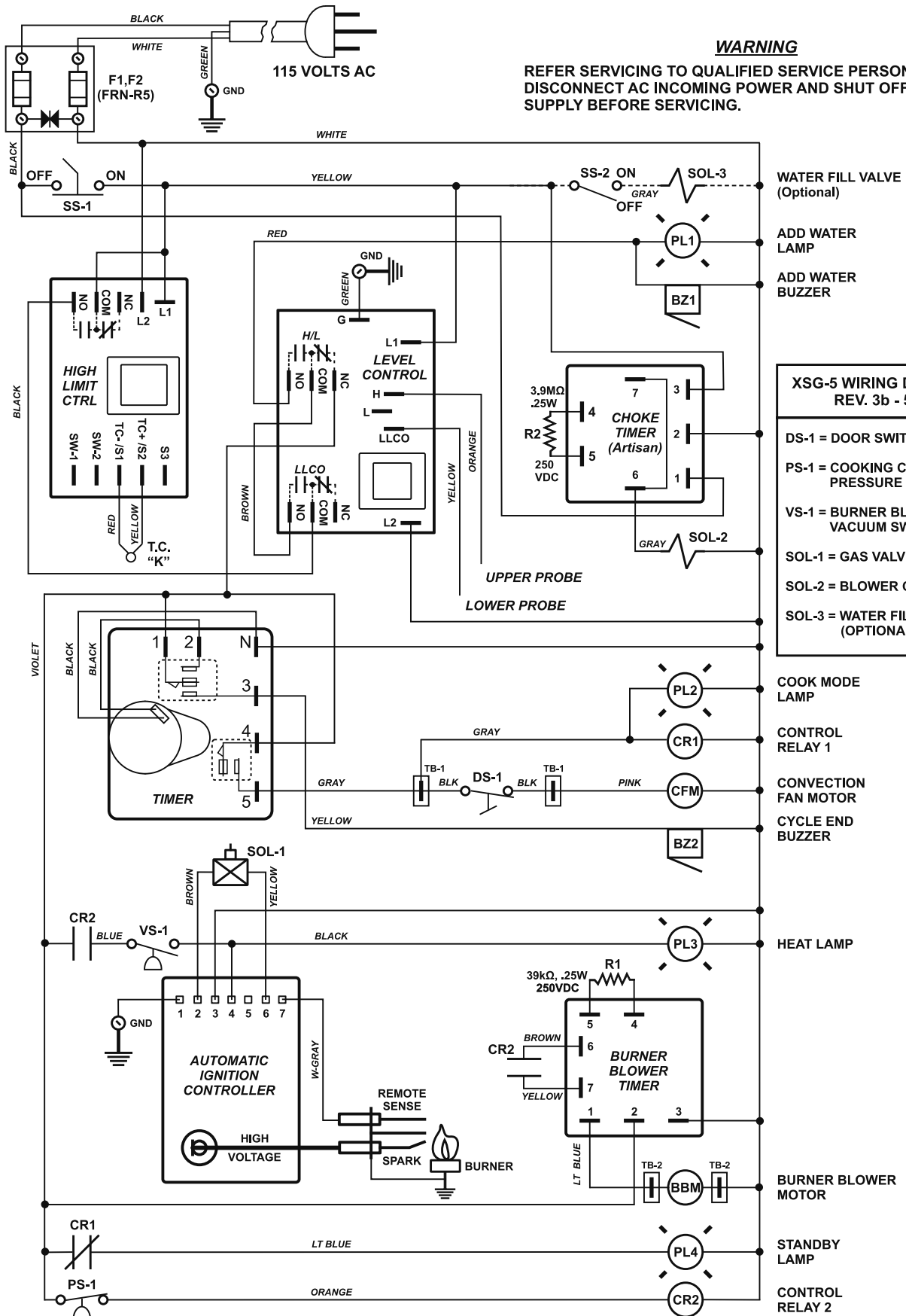

XSG-5 STANDARD TROUBLESHOOTING



XSG-5 STANDARD MODELS OPERATING AND SERVICE INFORMATION

IMPORTANT

The Lower Water Probe (located in reservoir) must be submerged before unit will turn on.
It is normal for the Heat Indicator Light to cycle ON and OFF.
The Convection Fan (CFM) is on only during the cooking cycle when the door is closed.

TROUBLESHOOTING GUIDE

SYMPTOM & POSSIBLE CAUSE

Unit does not turn "ON" no power:

1. Problem with facility breaker
2. No water in chamber
3. Blown fuse (F1/F2)
4. Faulty selector switch (SS-1)
5. Faulty lower water probe
6. Faulty water level control
7. Faulty high limit control

No ignition, heat light "ON":

1. Gas supply to unit is "OFF"
2. Faulty ignition control
3. Faulty igniter probe
4. Faulty gas solenoid valve

No ignition, heat light "OFF":

1. Faulty pressure switch. (PS1/PS2)
2. Faulty burner blower motor
3. Faulty control relay (CR2)
4. Faulty blower timer

Heat stays "ON" does not cycle:

Normal when door open

1. Faulty pressure switch. (PS2)
2. Faulty gas solenoid valve
3. Excessive steam leaking past door seal

Add water light illuminates with water in unit:

1. Faulty/Dirty upper water probe
2. Faulty water level control

Unit is slow to preheat and slow to recover:

1. Faulty pressure switch (PS2)
2. Steam orifice obstructed
3. Wrong size gas orifice
4. Wrong gas supply
5. Incorrect pressure at supply
6. Faulty gas burner

Unit shuts down during preheat and or normal operation:

1. Lime build up on chamber bottom
2. Faulty high limit control
3. Faulty high limit control
4. Faulty high limit thermocouple
5. Faulty lower water probe
6. Faulty water level control

Unit does not fill or overfills with water*:

1. Fill Switch (SS-2)
2. Water Inlet Valve (SOL-3)

* Units With Semi Water-Fill Option Only

FOR SERVICE SUPPORT CALL: 888-994-7636

XSG-5 AUTO-FILL WIRING DIAGRAM

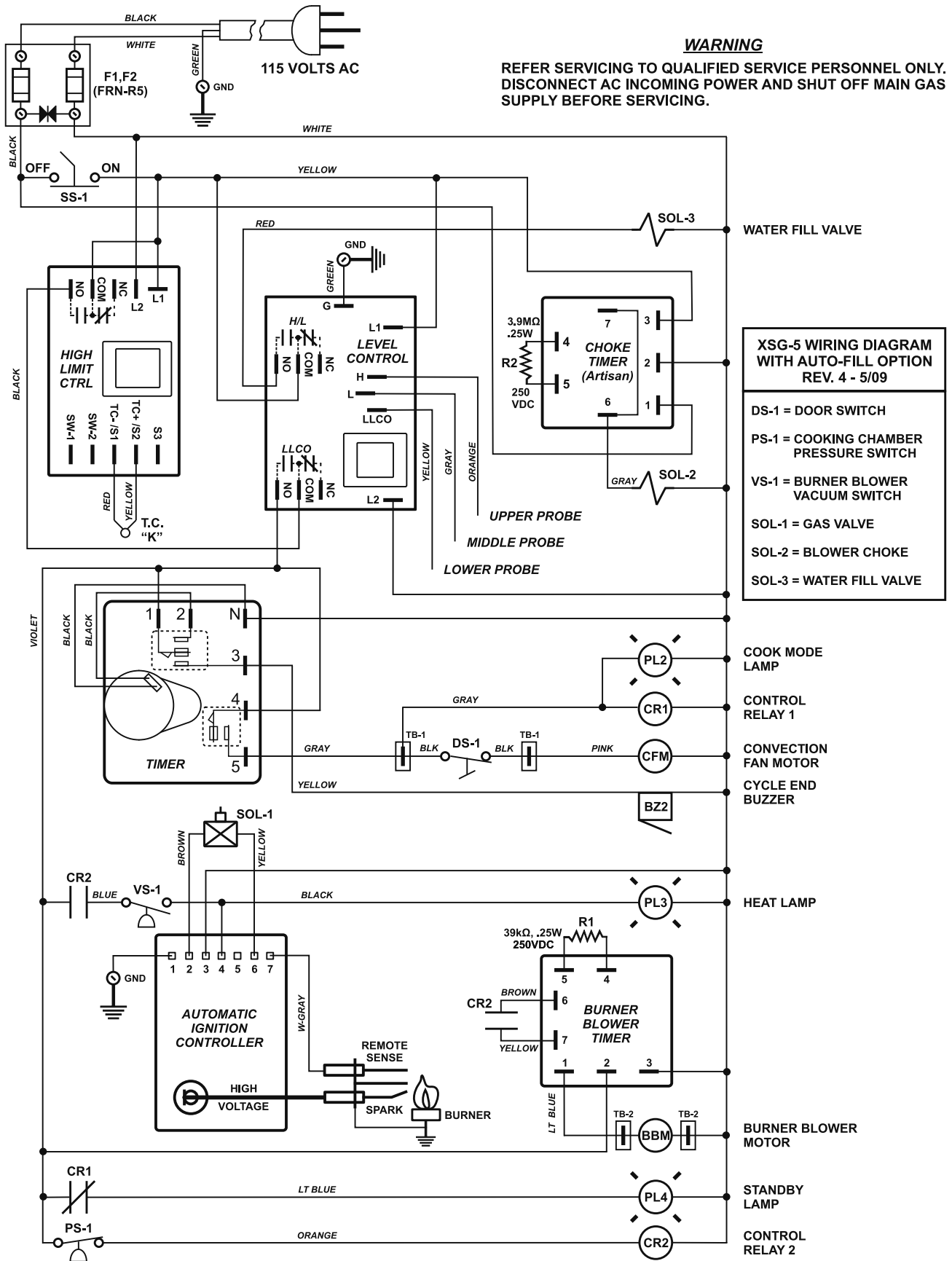

XSG-5 AUTO-FILL TROUBLESHOOTING



XSG-5 WITH AUTO-FILL OPTION OPERATING AND SERVICE INFORMATION

IMPORTANT

The Lower Water Probe (located in reservoir) must be submerged before unit will turn on.
It is normal for the Heat Indicator Light to cycle ON and OFF.
The Convection Fan (CFM) is on only during the cooking cycle when the door is closed.

TROUBLESHOOTING GUIDE

SYMPTOM & POSSIBLE CAUSE

Unit does not turn "ON" no power:

1. Problem with facility breaker
2. No water in chamber
3. Blown fuse (F1/F2)
4. Faulty selector switch (SS-1)
5. Faulty lower water probe
6. Faulty water level control
7. Faulty high limit control

No ignition, heat light "ON":

1. Gas supply to unit is "OFF"
2. Faulty ignition control
3. Faulty igniter probe
4. Faulty gas solenoid valve

No ignition, heat light "OFF":

1. Faulty pressure switch. (PS1/PS2)
2. Faulty burner blower motor
3. Faulty control relay (CR2)
4. Faulty blower timer

Heat stays "ON" does not cycle:

Normal when door open

1. Faulty pressure switch. (PS2)
2. Faulty gas solenoid valve
3. Excessive steam leaking past door seal

Add water light illuminates with water in unit:

1. Faulty/Dirty upper water probe
2. Faulty water level control

Unit is slow to preheat and slow to recover:

1. Faulty pressure switch (PS2)
2. Steam orifice obstructed
3. Wrong size gas orifice
4. Wrong gas supply
5. Incorrect pressure at supply
6. Faulty gas burner

Unit shuts down during preheat and or normal operation:

1. Lime build up on chamber bottom
2. Faulty high limit control
3. Faulty high limit control
4. Faulty high limit thermocouple
5. Faulty lower water probe
6. Faulty water level control

Unit does not fill at initial start:

1. Water level control PCB
2. Water inlet valve (SOL-3)

Unit does not refill during normal operation:

1. Water level control PCB
2. Defective / dirty middle water level probe
3. Water inlet valve (SOL-3)

Unit overfills:

1. Water level control PCB
2. Defective / dirty upper water level probe
3. Water inlet valve (SOL-3)

FOR SERVICE SUPPORT CALL: 888-994-7636

DO NOT remove either chimney assembly at any time during installation.

STEP 1) Prior to stand mounting, remove exhaust deflectors from both units by removing (3) 10-24 x 1/2 truss-head phillips screws (THPS) at indicated locations.

Original exhaust deflectors will not be re-used.

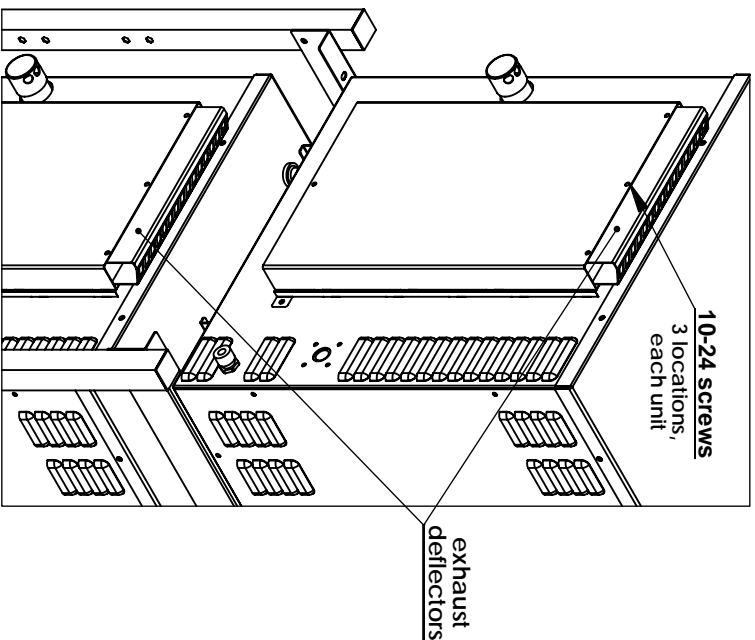

Tools required for installation:
Phillips screwdrivers
Rubber mallet (possibly)
7/16 wrench or 7/16 socket
with ratchet

Estimated time for installation:
20 minutes

XSG-5 Double-Stack Chimney Kit Installation (Rev. A 1/10)

Questions? Call 1-888-994-7636

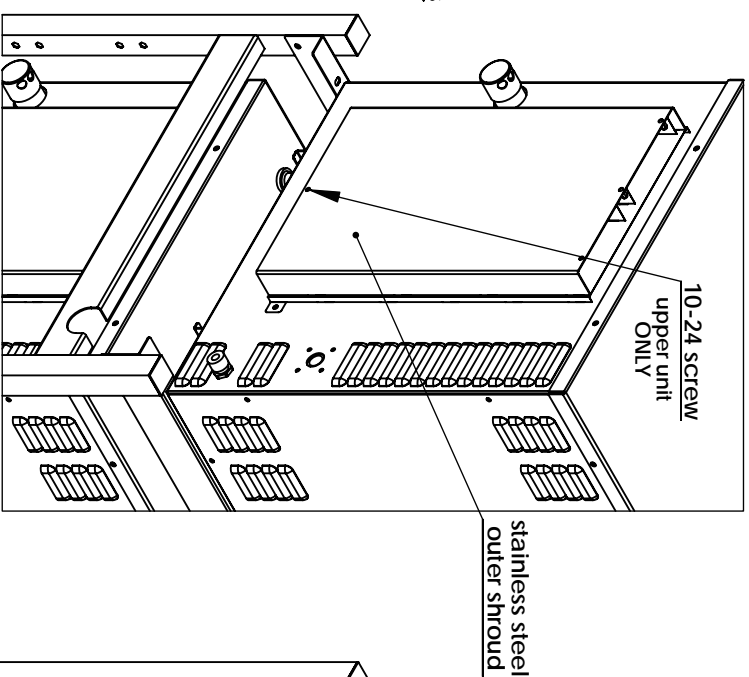

STEP 2) Remove stainless steel outer shroud from upper unit ONLY by removing (1) 10-24 x 3/4 THPS and nylon spacer at indicated location. Pull straight up on shroud to release (8) tabs from slots.

This shroud will not be re-used.

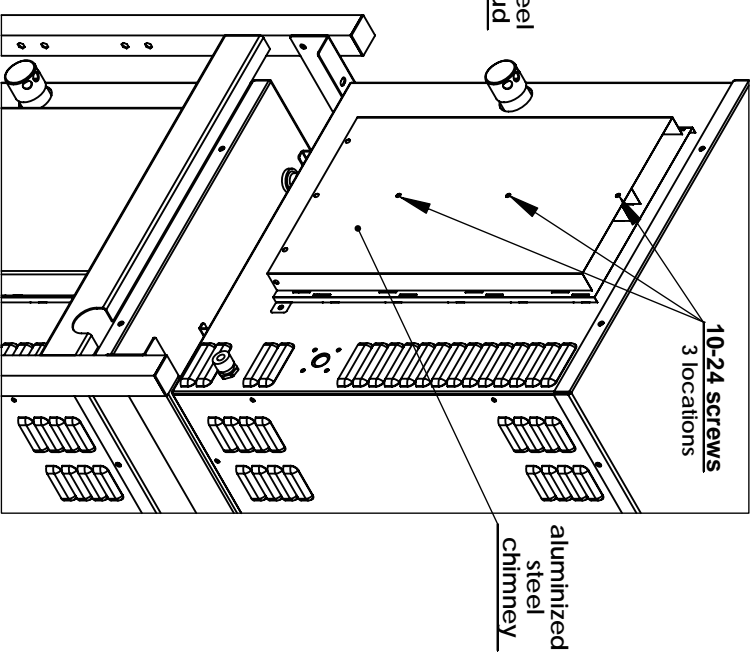

STEP 3) Remove (3) 10-24 x 1/2 THPS at indicated locations.
Leave aluminumized steel sheet metal chimney of upper unit in place.

BOTH STEAMERS MUST BE PROPERLY MOUNTED IN STAND BEFORE BEGINNING INSTALLATION OF CHIMNEY KIT

Both units should be secured to stand with (4) 1/4-20 x 3/4 bolts and lock washers, finger-tight.

NOTE: Stand brace is not shown in illustration

NOTE: This is a cutaway view

XSG-5 Double-Stack Chimney Kit Installation (Rev. A 1/10)

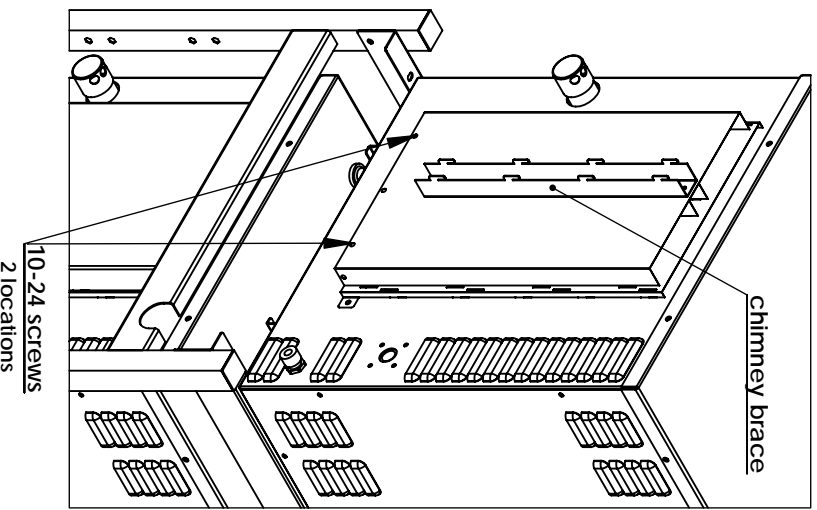
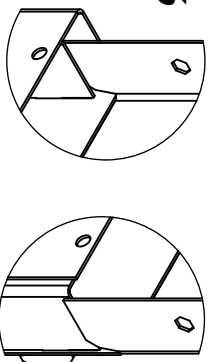

STEP 4) Attach chimney brace (M1600) as shown, with tabs facing up, using (3) 10-24 x 1/2 THPS. Remove (2) remaining screws at indicated location for next step.

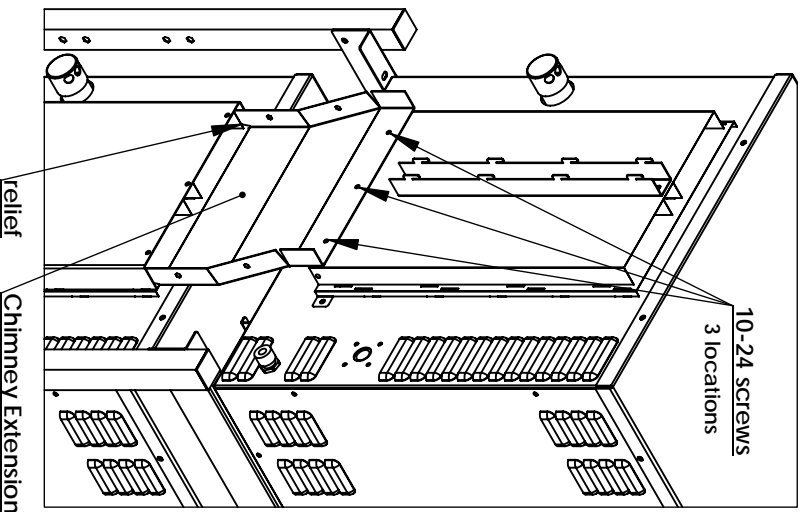

STEP 5) Attach first piece of lower unit chimney extension (M1601) as shown using (3) 10-24 x 1/2 THPS at indicated locations.

It is critical to install this piece correctly!

All flanges must be in the air space between the aluminized steel chimney and the surrounding stainless steel. Extension has relief area specifically to assist in installation. (See detail views) It may be necessary to move upper unit slightly to allow screw holes to line up.

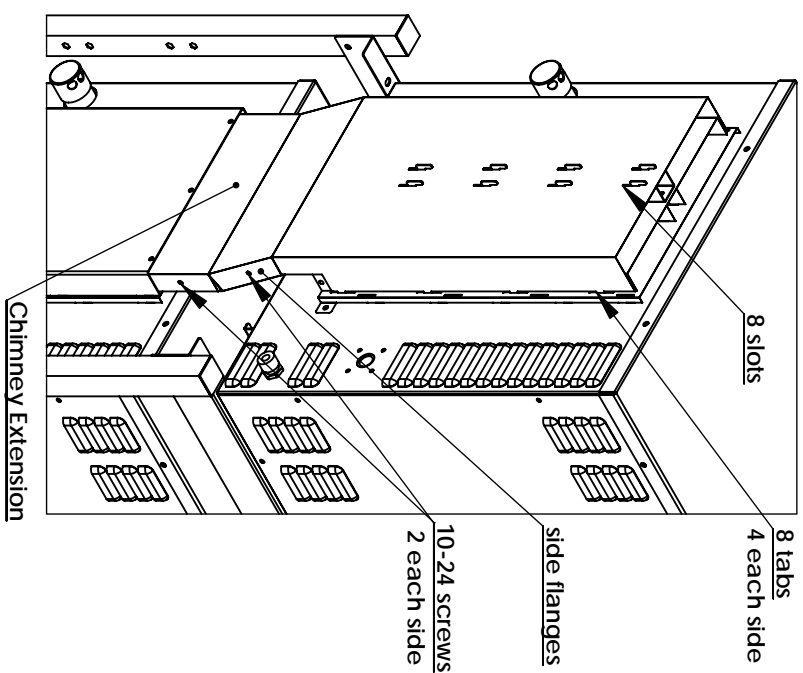

STEP 6) Attach second piece of lower unit chimney extension (M1602) by aligning 8 slots with tabs of chimney brace **AND** 8 tabs (4 each side) with slots in the upper unit's chimney assembly. The side flanges of this piece need to be on the outside of the extension piece installed in step 5. Once lined up, slide down forcefully to lock in place until screw holes line up. Use (4) 10-24 x 1/2 THPS at indicated locations to secure.

NOTE: Stand brace is not shown in illustration

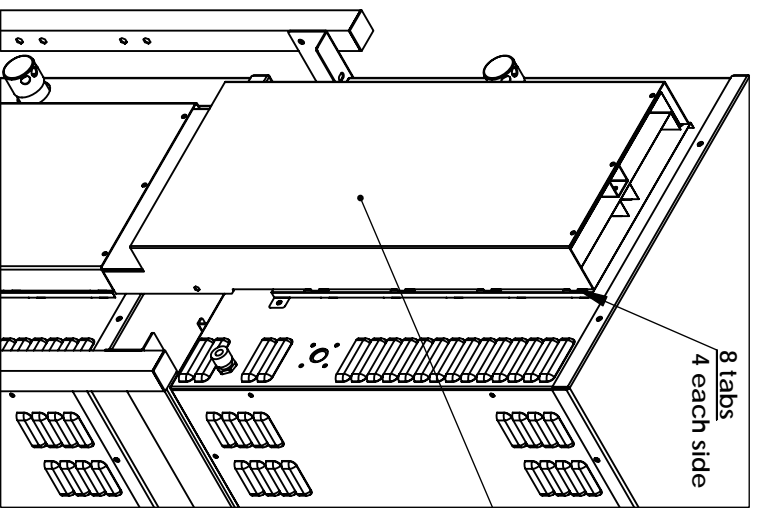

STEP 7) Attach new stainless steel outer shroud (M1608) by aligning 8 tabs with remaining slots in the upper unit's chimney assembly as shown. Slide down to lock in place. No screws are required to secure this piece in place.

NOTE: Stand brace is not shown in illustration

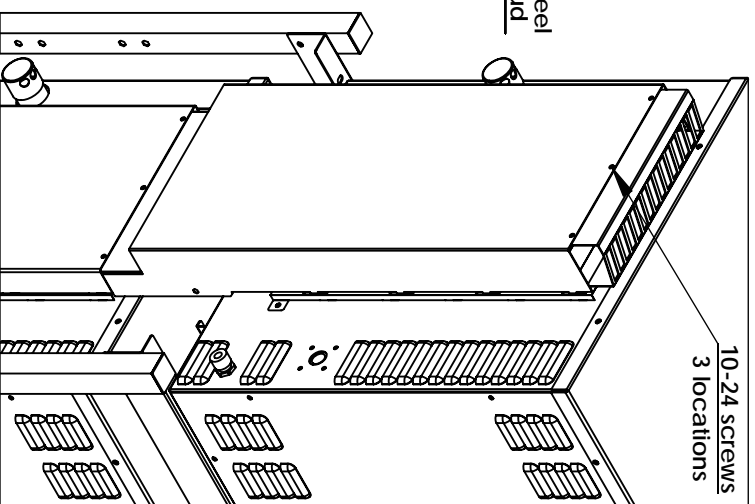

STEP 8) Insert new exhaust deflector (M1610) on the inside of new stainless steel outer shroud as shown, spanning both chimneys. Attach using (3) 10-24 x 1/2 THPS at indicated locations.

NOTE: Stand brace is not shown in illustration

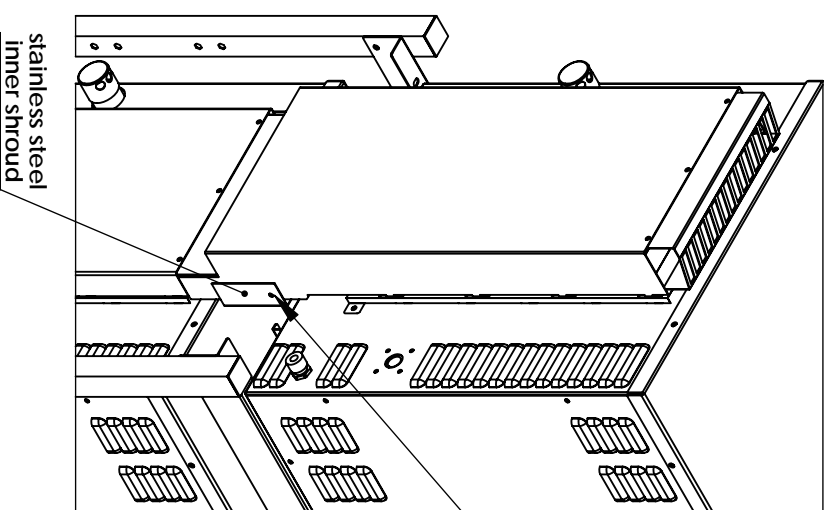

STEP 9) Position stainless steel inner shroud (M1609) between steamers and attach to outer shroud using (2) 10-24 x 1/2 THPS at indicated locations. Complete installation by tightening (8) 1/4-20 x 3/4 bolts (4 each unit) that secure steamers to stand.

NOTE: Stand brace is not shown in illustration

NORMAL OPERATING RANGE FOR BOTH NATURAL GAS & PROPANE

CO₂ / X-air	7 - 9 / 45 - 60
Eff.	78 - 85
O₂ / CO	4.0 - 8.0 / 0 - 100
CO_a	0 - 100

UL standard is less than 800ppm

Flame Sensor NG: 65 - 75 mV or greater

Flame Sensor PROPANE: 75 - 82 mV or greater

Nominal BTU=65,000

UL standard Operating Range +/- 2.5%:

63,375 - 66,625

Natural Gas: BTU/hr = Cubic Feet/hr x 1009 BTU/1 cubic ft

Propane: BTU/hr = Cubic Feet/hr x 2500 BTU/1 cubic ft

Measure cubic feet used in 5 minutes. Multiply that by 12 (to equal 60 minutes)

Multiply answer by the correct factor above to equal BTU/hr

XSG TOTAL AMPS AT ONE TIME

DESCRIPTION	AMPS
Convection Fan	0.34
Blower Motor	0.55
Lamp x 2	0.0048
Ignition Module	0.0005
Control Relay x 2	0.046
Buzzer	0.054
Water Fill Valve	0.083
Level Control Board	0.037
Watlow High Limit	0.083
Choke Solenoid	0.2
Gas Valve	0.08
Total	1.47

SERVICE BULLETIN #263

DATE: September 27, 2011

Models Affected: Extreme Steam Gas Steamers

Subject: Igniter /Sensor Probe NT1578

Purpose: To Prevent Ignition Related Failures

Issue: There is evidence of ignition problems that can be caused by improper igniter placement and improper gas pressure. The problems can be categorized in three ways:

- 1) Gas pressure is too high or too low
- 2) Part of the burner is making contact or close to the ignition electrode providing a ground such that either insufficient spark or no spark is present

Results: Experiencing issues such as; popping noise, intermittent burner operations, and burner appears to be burning gas inside the burner, unit running initially then stopping.

Corrective

Action The action depends on the problem category. If you experience a popping noise at the burner; check for proper gas pressure at the incoming supply line, gas valve or manifold. Nat. Gas supply to be set at 3.5 and Lp to be set at 10.0

If you experience the unit igniting and operating intermittently shutting down during operation. Remove the Igniter and check the spark gap (should be 1/4") (see figure 2A). Check the igniter and sensor probe to make sure they are not too close or touching the burner also check to make sure the burner has not ignited and is burning internally or back-flashing (see figure 1A). If this occurs the Igniter and ground should be bent 1/4" away from the burner (See figure 1A).

Extreme Steam Gas Steamers

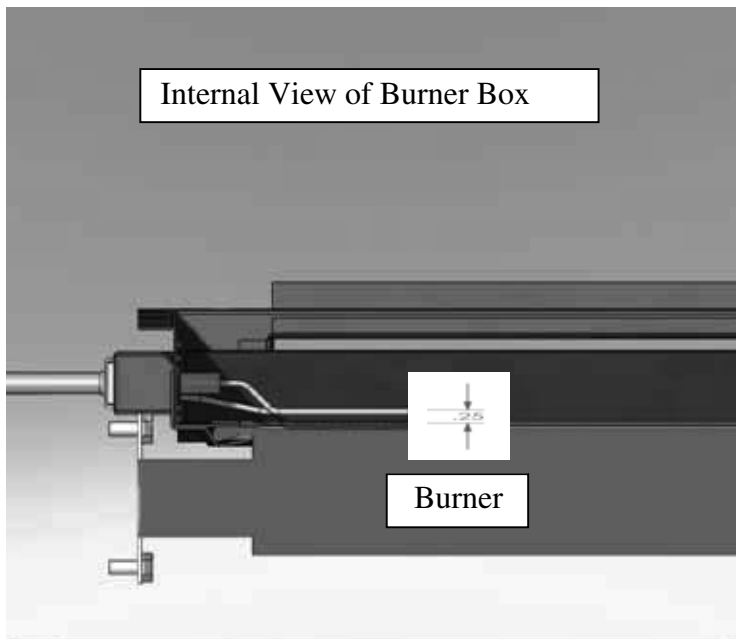

Figure1A. The Igniter E1578 and ground should be 1/4" away from the burner

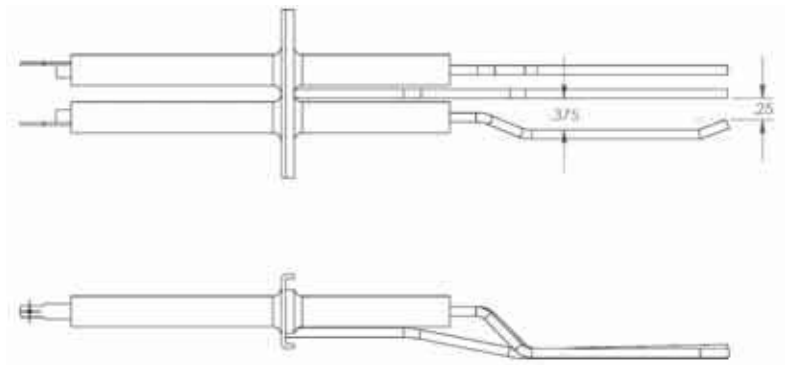

Figure 2A. The 1/4" space require between Igniter E1578 and ground

For any further details or questions contact the Groen Technical Support at 1-800-676-9040.

INTEK XTREME STEAM BURNER "NT1562" REPLACEMENT

STEP 1-5 BURNER REMOVAL

Step 1



Remove the Right-hand side panel and (4) screws in the rear at incoming gas connection using and (4) nuts securing the bracket with a Philips head screwdriver

Step 2



Remove the (2) screws from ignitor, and disconnect the wires to the choke
Remove (4) 1/4x20 nuts supporting the blower /choke and remove the blower/choke

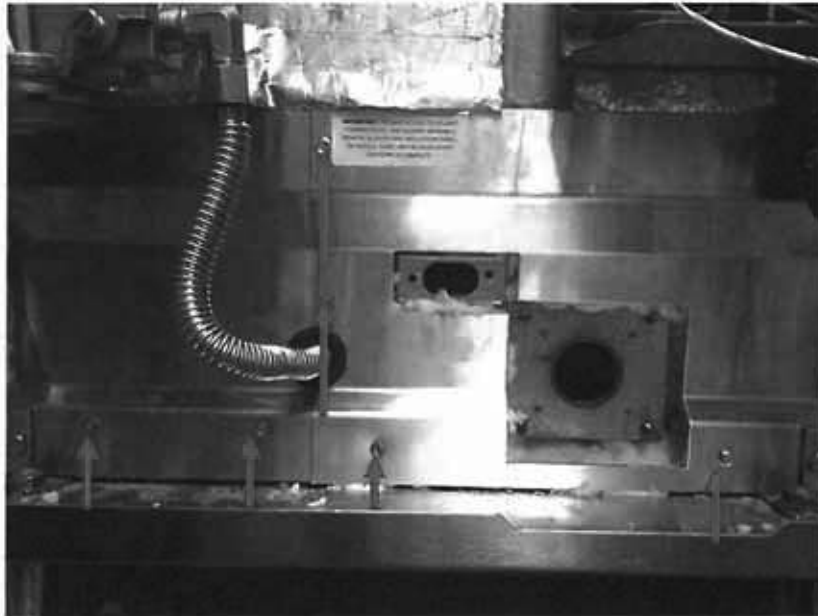

Step 3

Remove the Right and Left heat shields and insulation by removing (6) 8-32x1/2 screws

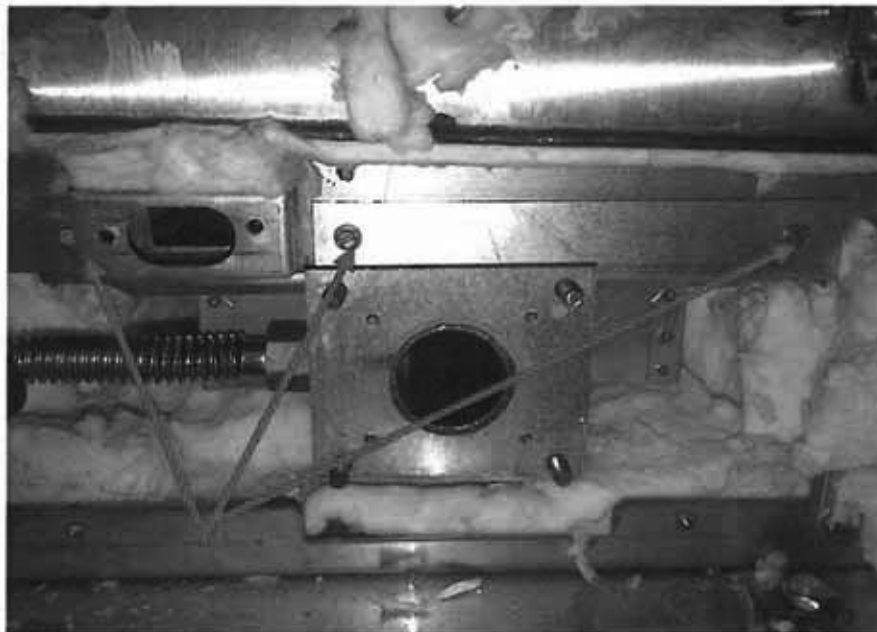

Step 4

Remove (3) 8-32 x1/2 hex slot screws in burner support bracket and slide burner out



Step 5

Remove burner support bracket and use a crescent wrench to remove the gas line from the burner and slide the old burner out.

STEP 1-6 BURNER INSTALLATION



Step 1

Apply pipe dope to the orifice, use 11/16 socket to tighten during install



Step 2

Slide the new burner onto the burner support brackets and add the support bracket for the top. Attach the gas line and tighten with a crescent wrench

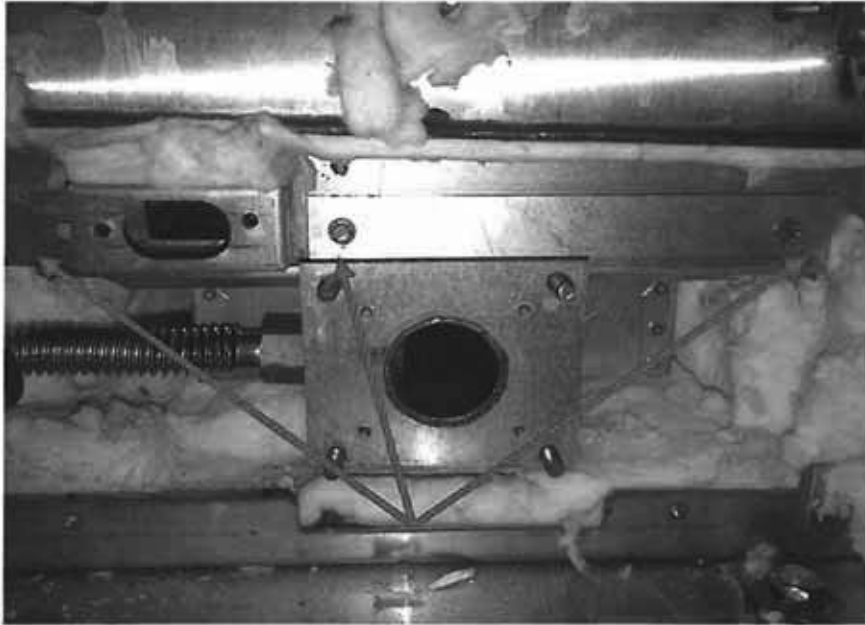

Step 3

Install (3) 8-32 x1/2 hex slot screws into burner support bracket and slide burner out

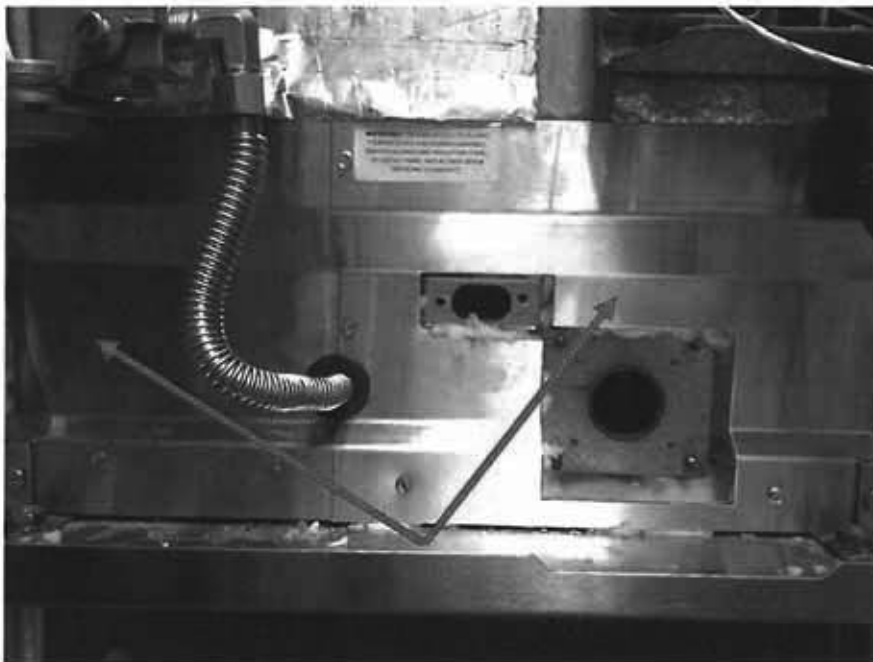

Step 4

Install insulation, Left and Right heat shields using (6) 8-32x1/2 hex slot screw and grommet for flexible gas line



Step 5

Install (2) 8-32 x1/2 hex slot screws for the ignitor and sensor, connect ignition cable and sensor. Install (4) 1/4x20 nuts supporting the blower /choke and connect the blower/choke wires



Step 6

Install (4) Philips head screws and (4) nuts in the rear at incoming gas connection using a Philips head screwdriver. Check for gas leaks, install right side panel



A **DOVER** COMPANY

1055 Mendell Davis Drive • Jackson MS 39272
888-994-7636 • 601-372-3903 • Fax 888-864-7636
unifiedbrands.net