

# OPERATOR MANUAL

IMPORTANT INFORMATION, KEEP FOR OPERATOR

This manual provides information for:

## **HY-3E(CE) & HY-5E(CE)** **HYPERSTEAM™** **ATMOSPHERIC CONVECTION** **STEAMER INTERNATIONAL**

- Self Contained
- Electric Heated
- Capacity: 3 or 5 Steamer Pans (305 x 508 x 64mm)



CE  
0086



THIS MANUAL MUST BE RETAINED FOR FUTURE REFERENCE.  
READ, UNDERSTAND AND FOLLOW THE INSTRUCTIONS AND  
WARNINGS CONTAINED IN THIS MANUAL.

### WARNING

Improper installation, adjustment, alteration, service or maintenance can cause property damage, injury or death. Read the installation, operating and maintenance instructions thoroughly before installing or servicing this equipment.

### NOTIFY CARRIER OF DAMAGE AT ONCE

It is the responsibility of the consignee to inspect the container upon receipt of same and to determine the possibility of any damage, including concealed damage. Unified Brands suggests that if you are suspicious of damage to make a notation on the delivery receipt. It will be the responsibility of the consignee to file a claim with the carrier. We recommend that you do so at once.

Manufacture Service/Questions 888-994-7636.

Information contained in this document is known to be current and accurate at the time of printing/creation. Unified Brands recommends referencing our product line websites, [unifiedbrands.net](http://unifiedbrands.net), for the most updated product information and specifications.

PART NUMBER 128174, REV G (07/14)

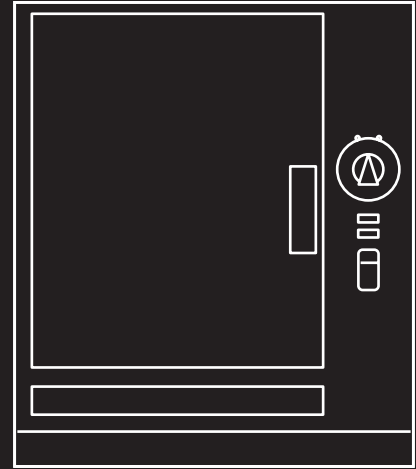

1055 Mendell Davis Drive  
Jackson, MS 39272  
888-994-7636, fax 888-864-7636  
[unifiedbrands.net](http://unifiedbrands.net)

# IMPORTANT - READ FIRST - IMPORTANT

THESE APPLIANCES MUST BE INSTALLED BY A COMPETENT PERSON IN CONFORMITY WITH THE INSTALLATION AND SERVICING INSTRUCTIONS AND NATIONAL REGULATIONS IN FORCE AT THE TIME. PARTICULAR ATTENTION MUST BE PAID TO THE FOLLOWING:

I. E. E. REGULATIONS FOR ELECTRICAL INSTALLATIONS  
ELECTRICITY AT WORK REGULATIONS  
HEALTH AND SAFETY AT WORK ACT  
FIRE PRECAUTIONS ACT  
LOCAL AND NATIONAL BUILDING REGULATIONS

USERS SHOULD BE CONVERSANT WITH THE APPROPRIATE PROVISIONS OF THE FIRE PRECAUTIONS ACT. IN PARTICULAR THEY SHOULD BE AWARE OF THE NEED FOR REGULAR SERVICING BY A COMPETENT PERSON TO ENSURE THE CONTINUED SAFE AND EFFICIENT PERFORMANCE OF THE APPLIANCE.

**WARNING:** TO PREVENT SHOCKS, ALL APPLIANCES WHETHER GAS OR ELECTRIC, MUST BE EARTHED. UPON COMPLETION OF THE INSTALLATION, THE OWNERS MANUAL SHOULD BE HANDED TO THE USERS AND THE INSTALLER SHOULD INSTRUCT THE RESPONSIBLE PERSON(S) IN THE CORRECT OPERATION AND MAINTENANCE OF THE APPLIANCE.

THIS EQUIPMENT IS ONLY FOR PROFESSIONAL USE, AND SHALL BE OPERATED BY QUALIFIED PERSONS. IT IS THE RESPONSIBILITY OF THE SUPERVISOR OR EQUIVALENT TO ENSURE THAT USERS WEAR SUITABLE PROTECTIVE CLOTHING AND TO DRAW ATTENTION TO THE FACT THAT, SOME PARTS WILL, BY NECESSITY, BECOME VERY HOT AND WILL CAUSE BURNS IF TOUCHED ACCIDENTALLY.

UNLESS OTHERWISE STATED, PARTS WHICH HAVE BEEN PROTECTED BY THE MANUFACTURER ARE NOT TO BE ADJUSTED BY THE INSTALLER.

**WARNING:** AVOID ANY EXPOSURE TO THE STEAM COMING OUT WHEN OPENING THE DOOR. BEFORE ATTEMPTING ANY SERVICING, ENSURE THAT THE ELECTRICAL SUPPLY IS DISCONNECTED.

**WARNING:** THE UNIT MUST BE INSTALLED BY PERSONNEL QUALIFIED TO WORK WITH ELECTRICITY AND PLUMBING. IMPROPER INSTALLATION CAN CAUSE INJURY TO PERSONNEL AND/OR DAMAGE TO THE EQUIPMENT. THE UNIT MUST BE INSTALLED IN ACCORDANCE WITH APPLICABLE CODES.

**CAUTION:** SHIPPING STRAPS ARE UNDER TENSION AND CAN SNAP BACK WHEN CUT.

**CAUTION:** DO NOT INSTALL THE UNIT IN ANY WAY WHICH WILL BLOCK THE RIGHT SIDE VENTS, OR WITHIN 12 INCHES OF A HEAT SOURCE SUCH AS A BRAISING PAN, DEEP FRYER, CHARBROILER OR KETTLE.

**CAUTION:** LEVEL THE UNIT FRONT TO BACK, OR PITCH IT SLIGHTLY TO THE REAR, TO AVOID DRAINAGE PROBLEMS.

**WARNING:** TO AVOID DAMAGE OR INJURY, FOLLOW THE WIRING DIAGRAM EXACTLY WHEN CONNECTING A UNIT.

**CAUTION:** DO NOT USE PLASTIC PIPE. DRAIN MUST BE RATED FOR BOILING WATER.

**WARNING:** DO NOT CONNECT THE DRAIN DIRECTLY TO A BUILDING DRAIN.

**WARNING:** BLOCKING THE DRAIN IS HAZARDOUS.

**IMPORTANT:** IMPROPER DRAIN CONNECTION WILL VOID WARRANTY.

# IMPORTANT - READ FIRST - IMPORTANT

- IMPORTANT:** DO NOT ALLOW ANY WATER TRAPS IN THE LINE. A TRAP CAN CAUSE PRESSURE TO BUILD UP INSIDE THE CAVITY DURING STEAMING, WHICH WILL MAKE THE DOOR GASKET LEAK.
- WARNING:** WHEN YOU OPEN THE DOOR, STAY AWAY FROM STEAM COMING OUT OF THE UNIT. STEAM CAN CAUSE BURNS.
- WARNING:** BEFORE CLEANING THE OUTSIDE OF THE STEAMER, DISCONNECT THE ELECTRIC POWER SUPPLY. KEEP WATER AND CLEANING SOLUTIONS OUT OF CONTROLS AND ELECTRICAL COMPONENTS. NEVER HOSE OR STEAM CLEAN ANY PART OF THE UNIT.
- WARNING:** ALLOW COOKING CHAMBER TO COOL BEFORE CLEANING.
- WARNING:** CAREFULLY READ THE WARNINGS AND FOLLOW THE DIRECTIONS ON THE LABEL OF EACH CLEANING AGENT. USE SAFETY GLASSES AND RUBBER GLOVES AS RECOMMENDED BY DE-LIMING AGENT MANUFACTURER.
- WARNING:** DO NOT MIX DE-LIMING AGENTS (ACID) AND DE-GREASERS (ALKALI).
- WARNING:** DO NOT PUT HANDS OR TOOLS INTO THE COOKING CHAMBER UNTIL THE FAN HAS STOPPED TURNING.
- WARNING:** DO NOT OPERATE THE UNIT UNLESS THE REMOVABLE LEFT AND RIGHT SIDE PANELS HAVE BEEN RETURNED TO THEIR PROPER LOCATIONS.
- NOTICE:** DO NOT USE A CLEANING OR DE-LIMING AGENT THAT CONTAINS ANY SULFAMIC ACID OR ANY CHLORIDE, INCLUDING HYDROCHLORIC ACID. IF THE CHLORIDE CONTENT OF ANY PRODUCT IS UNCLEAR, CONSULT THE MANUFACTURER.
- NOTICE:** DO NOT USE ANY DE-GREASER THAT CONTAINS POTASSIUM HYDROXIDE OR SODIUM HYDROXIDE OR THAT IS ALKALINE.
- WARNING:** USE OF ANY REPLACEMENT PARTS OTHER THAN THOSE SUPPLIED BY GROEN OR THEIR AUTHORIZED DISTRIBUTOR VOIDS ALL WARRANTIES AND CAN RESULT IN BODILY INJURY TO THE OPERATOR AND DAMAGE THE EQUIPMENT. SERVICE BY OTHER THAN FACTORY AUTHORIZED PERSONNEL WILL VOID ALL WARRANTIES.
- WARNING:** HIGH VOLTAGE EXISTS INSIDE CONTROL COMPARTMENTS. DISCONNECT FROM BRANCH BEFORE SERVICING. FAILURE TO DO SO CAN RESULT IN SERIOUS INJURY OR DEATH.

# Table of Contents

Important Operator Warnings .....	page 2-3
References.....	page 4
Equipment Description.....	page 5
Inspection and Unpacking .....	page 5
Water Conditioning .....	page 6
Installation & Start-Up .....	page 7-9
Operation .....	page 10-11
Cleaning.....	page 12-13
Maintenance.....	page 14
Troubleshooting.....	page 14
Electrical Schematic .....	page 21-22
Service Procedures .....	page 23-34
Service Log .....	page 35

## References

UNDERWRITERS LABORATORIES, INC.  
333 Pfingsten Road  
Northbrook, Illinois 60062

NATIONAL FIRE PROTECTION ASSOCIATION  
60 Batterymarch Park  
Quincy, Massachusetts 02269

NFPA/70 The National Electrical Code

NSF INTERNATIONAL  
789 N. Dixboro Rd.  
P.O. Box 130140  
Ann Arbor, Michigan 48113

KLENZADE SALES CENTER  
ECOLAB, Inc.  
370 Wabasha  
St. Paul, Minnesota 55102  
800 328-3663 or 612 293-2233

## Equipment Description



The HY-5E steamer holds five standard 305 mm x 508 mm x 64 mm deep pans.



The HY-3E steamer holds three standard 305 mm x 508 mm x 64 mm deep pans.

Your Groen HY-3E or HY-5E HyPerSteam Convection Steamer is designed to give years of service. It has a stainless steel cavity (cooking chamber) which is served by an independent atmospheric steam generator which is electrically heated. A powerful blower circulates the steam in the cavity to increase heating efficiency.

The cavity holds up to three (HY-3E) or five (HY-5E) standard steam table pans. A 1.5 mm thick stainless steel case encloses the cavity, the steam generator and the control compartment that houses electrical components. Door hinges are reversible (the door may be set to open from the left or right). Operating Controls are on the front panel.

Model HY-3E steamers and HY-5E steamers are equipped with fully electronic controls and a button activated, pre-programmed CLEAN cycle. These units are readily identified by their unique control panels, with touch pad controls, and the distinctive symbol for steam is integrated into the panel.

Both units are distinguished by the addition of a “fuse box” which allows the operator to change fuses without removing panels.

The drain system on all models includes a spray condenser, which helps keep steam from escaping from the chamber and cools drain water.

## Inspection & Unpacking

**CAUTION**  
SHIPPING STRAPS ARE UNDER TENSION  
AND CAN SNAP BACK WHEN CUT.

**CAUTION**  
THIS UNIT WEIGHS 82 KG (HY-3E) OR 105 KG  
(HY-5E). YOU SHOULD GET HELP AS NEEDED  
TO LIFT THIS WEIGHT SAFELY.

The HY-3E or HY- 5E will be delivered completely assembled in a heavy shipping carton attached to a skid. On receipt, inspect the carton carefully for exterior damage.

Carefully cut the straps around the carton and detach the sides of the carton from the skid. Pull the carton up off the unit. Be careful to avoid personal injury or equipment damage from staples which might be left in the carton walls.

Write down the model number, serial number and installation date. Keep this information for reference. Space for these entries is provided at the top of the Service Log in the back of this manual.

When starting installation, lift the unit straight up off the skid. Check packing materials to make sure loose parts such as the condensate drip tray are not discarded with this material.

# Water Conditioning

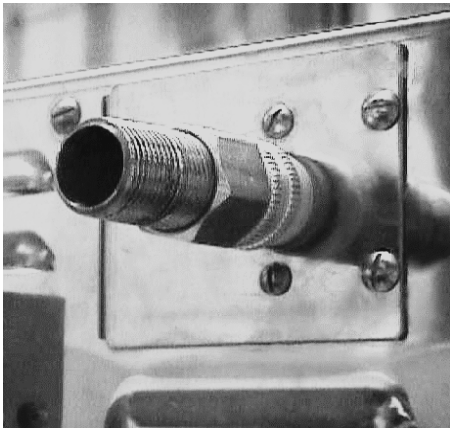

A BSPT connection is provided at the rear of the steamer.

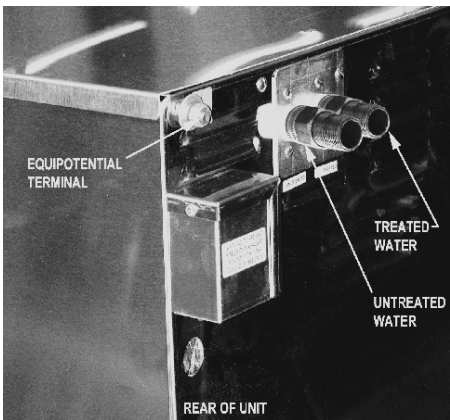

The optional second water connection can reduce treated water requirements.

It is essential to supply the steam generator with water that will not form scale or cause corrosion. Even though the steam generator is engineered to minimize scale formation and the effects of corrosion, their development depends on the quality of your water and the number of hours per day you operate the equipment.

Most water supplies are full of minerals and chemicals which are not suitable for use in a steam generator.

Water quality varies from state to state and city to city. It is necessary that you know and understand the quality of the water you are using. Your water utility can tell you about the minerals and chemicals in your water. The water going to the steam generator should be within these guidelines

Water Pressure	30-60 psi
PH	7 to 9
Hardness	less than 60 ppm
TDS	30 to 60 ppm
Chlorine and Chloramine	less than 0.1 ppm
Total Chloride	less than 30 ppm
Silica	less than 12 ppm
Undissolved Solids	less than 5 microns

1. Do not rely on unproven water treatments which are sold for scale prevention or scale removal. They don't always work. The best way to prevent scale is to supply the purest possible water (30 - 60 ppm TDS).
2. If your water contains scale-forming minerals, as most water does, use a well-maintained water softener. Whether an exchangeable softener cartridge or a regenerating system is chosen, a regular exchange schedule is essential.
3. Installing a water meter between the softener and the steamer will provide an accurate gauge of water use, and will help determine when to exchange cartridges or regenerate the softener. Using a water softener will provide longer generator life, higher steam capacity, and reduce maintenance requirements.
4. If you notice a slowdown in steam production, have the unit checked for scale build-up. Heavy scale reduces the unit's ability to boil water and can even cause heating elements in the steam generator to overheat and burn out.

# Installation & Start-Up

## WARNING

THE UNIT MUST BE INSTALLED BY PERSONNEL WHO ARE QUALIFIED TO WORK WITH ELECTRICITY AND PLUMBING. IMPROPER INSTALLATION CAN CAUSE INJURY TO PERSONNEL AND/OR DAMAGE TO THE EQUIPMENT. THE UNIT MUST BE INSTALLED IN ACCORDANCE WITH APPLICABLE CODES.

## CAUTION

DO NOT INSTALL THE UNIT WITH THE RIGHT OR LEFT SIDE VENTS BLOCKED OR WITHIN 305 mm OF A HEAT SOURCE (SUCH AS A BRAISING PAN, DEEP FRYER, CHAR BROILER OR KETTLE). TO AVOID DRAINAGE PROBLEMS, LEVEL THE UNIT FRONT TO BACK.

## CAUTION

THE UNIT MUST HAVE A SEPARATE GROUND WIRE FOR SAFE OPERATION.

## WARNING

TO AVOID DAMAGE OR PERSONAL INJURY, FOLLOW THE ELECTRICAL SCHEMATIC EXACTLY WHEN CONNECTING THE UNIT.

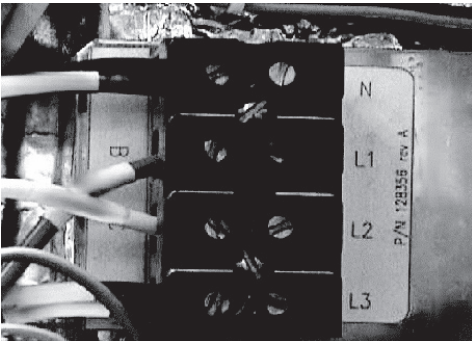

HY-3E Electrical Connections

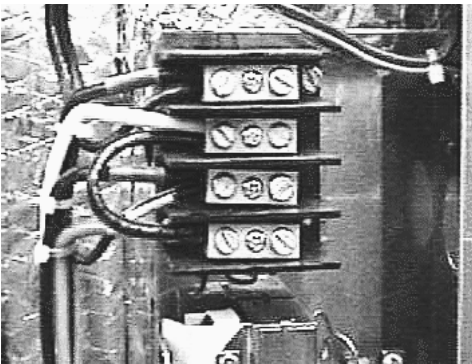

HY-5E Terminal Block

## ELECTRICAL SUPPLY CONNECTION

### 1. Panel Removal

Open the wiring and control panel by removing the screws on the right side panel. Slide the panel forward, and set it aside.

### 2. Supply Voltage

The unit must be operated at the rated nameplate voltage.

### 3. Phase Selection

Refer to heater schematics (Pages 21 and 22) for wiring information.

### 4. Terminal Block

The terminal block for incoming power is located at the back of the control compartment. The ground terminal is located in the wiring compartment near the terminal block.

### 5. Supply Wire

To determine the type of wire you need for the power supply, find the operating voltage and phase on the unit data plate. Use the correct wire size to meet the current demand as shown in the table, below and as required by regulations. The knockout hole is sized for a 35 mm conduit fitting.

The HY-3E HyPerSteam™ and HY-5E model convection steamers operate at 400 Volts (Three Phase ‘delta’ with Neutral) or 230 Volts (One Phase). Separate part numbers are offered for 50 Hz and 60 Hz operation to supply the appropriate electro-mechanical timer, since they synchronize with the Mains Power frequency.

Model	Voltage	Max. Kw	Nominal Current Demands
HY-3E	400 - 3 Phase	8	13 Amps
	230 - 1 Phase	8	33 Amps
HY-5E	400 - 3 Phase	15.5	23 Amps
	230 - 1 Phase	15.5	63 Amps

Connect appropriate wiring as described in the wiring diagram located on the inside of the unit's right side panel. Incoming power connections are shown at left.

# Installation & Start-Up

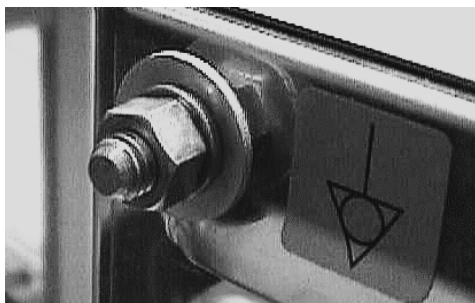

The equipotential terminal is located on the left rear of the units.

## WARNING

**DO NOT CONNECT THE DRAIN DIRECTLY TO A BUILDING DRAIN. BLOCKING THE DRAIN IS HAZARDOUS.**

## CAUTION

**DO NOT USE PLASTIC PIPE. DRAIN MUST BE RATED FOR VERY HOT WATER.**

## 6. Equipotential Terminal

In accordance with national regulations, each unit are fitted with an equipotential terminal.

## 7. Branch Circuit Protection

Each HY-3E Steamer should have its own branch circuit protection. Current and power demands for the different units are as shown in the table on page seven.

## WATER CONNECTION(S)

Water pressure in the line should be between 30 and 60 PSIG (210 and 420 kPa) and deliver a flow rate of 5.7 to 11.4 liters per minute. If pressure is above 60 PSIG (420 kPa), a pressure regulator will be needed.

A 3/4" BSPT connector is used to attach the water supply to the inlet valves. Minimum water feed line diameter is 1/2" (13 mm). Use a washer in the hose connection. Do not allow the connections to leak, no matter how slowly. Treated (softened) water goes to the right (seen from the rear of the unit) and untreated water goes to the left. Connections are made as shown on the previous pages.

On each water line, install a WRAS approved double-check valve or an equally effective back flow preventative device in the incoming cold water lines at the point of connections to the steamer and in compliance with all local plumbing codes. This installation must be per WRAS-IRN R160 Schedule 2-15 (1).

Water Quality Requirements: For proper steam generator performance, Total Dissolved Solids (TDS) should not exceed 30 parts per million (ppm), and the water pH should be 7.1 or higher.

## DRAIN CONNECTION

Level the steamer front to back, or even pitch it slightly to the rear by adjusting the bullet feet on the stand or cabinet base.

A two inch (50mm) [HY-5E] or 1½ inch (38 mm) [HY-3E] ID hose should be attached to the drain pipe and elbow supplied. It must be rated for 100°C water.

There must be at least one-half inch free air gap between the end of the hose and the building drain. The free air gap should be as close as possible to the unit drain. There must also be no other elbows or other restrictions between the unit drain and the two inch free air gap.

Install the drain line with a constant downward pitch. **IMPORTANT:** Do not allow water traps in the line. A trap can cause pressure build-up in the cavity, which may cause the door gasket to leak.



# Installation & Start-Up

**WARNING**  
DO NOT CONNECT THE UNIT DRAIN DIRECTLY TO THE BUILDING DRAIN.

**CAUTION**  
DO NOT USE PLASTIC PIPE. DRAIN MUST BE RATED FOR VERY HOT WATER.

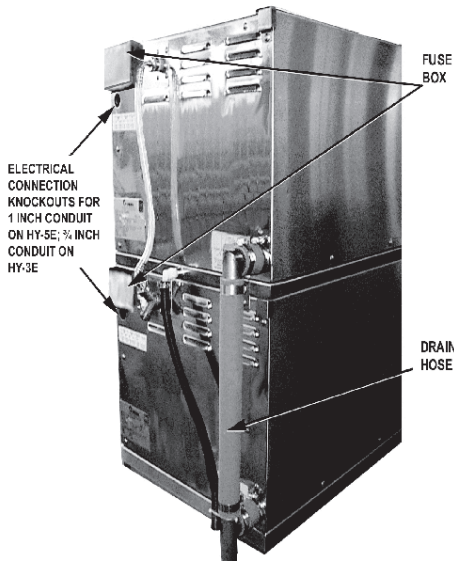

## FACTORY STACKED UNITS

This section is applicable only if you are installing factory-stacked units. If you plan to stack steamers yourself, whether purchasing a new one for stacking or a kit to stack two units you already own, you will require OM-HY-3E(S), RETROFIT SUPPLEMENT (Part Number 121014). These instructions are also valid for stacking HY-5E steamers.

Installing stacked steamers is similar to installing a single unit. The steamers are stacked and assembled at the factory and delivered with the water connections and drain hoses required for a single point connection.

### 1. Water Connection

The same water supply connection is used for both units. At the water level inlet valve a 3/4" BSPT connector (garden hose type) is used for the water supply. Treated water (softened) is connected to the right valve fitting (looking from the rear of the unit) and untreated water to the left fitting.

### 2. Electrical Supply Connection

Separate, individual electrical connections will be required for each steamer in the stack. Each Steamer must have its own branch circuit protection.

### 3. Water Connection

Steamers must be leveled front to back, or pitched to the rear (maximum 6 mm) by adjusting the bullet feet on the cabinet or stand base.

For HY-3E a 38 mm (1½ inch) and for HY-5E or 50 mm (2 inch) ID hose may be attached to the unit drain. It must be rated for 100°C.

Rear view of (2) HY-5E. **NOTE:** Some drain parts (elbow, clamps) for single models are packed inside the steamer cavity. Stacked units are factory assembled. Installation is the same for stacked HY-5E and HY-3E units.

Ensure that there is a free air gap between the end of the unit drain and the building drain. This gap should be as close as possible to the unit drain. Do not allow elbows or restrictions between the unit and the free air gap.

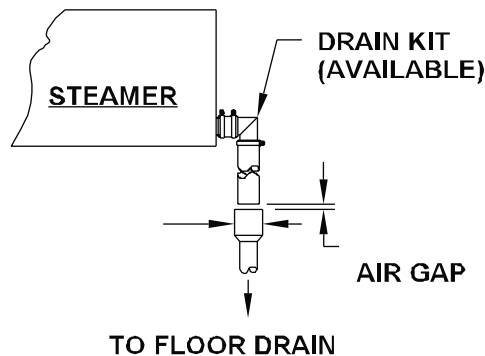
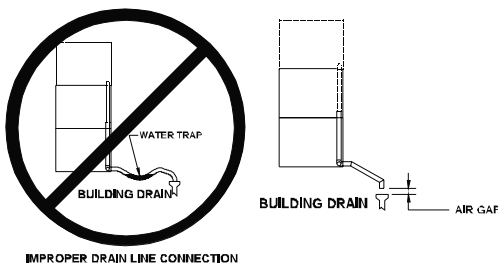

Proper Drain Line Connection. Drain Line must have a constant downward pitch of at least 6 mm (¼") per foot. Connection is 38 mm (1½") for HY-3E, 50 mm (2") for HY-5E. (3)HY-3E shown.

## COUNTER-MOUNTED UNITS

This section is applicable if the steamer will be mounted to a counter. All four edges of the bottom of the steamer must be sealed with RTV to the counter if the 4 inch legs are not used. Counter must be made of a noncombustible material such as metal or tile.

# Operation

**WARNING**  
ANY POTENTIAL USER OF THE EQUIPMENT SHOULD BE TRAINED IN SAFE AND CORRECT OPERATING PROCEDURES.

**WARNING**  
WHEN YOU OPEN THE DOOR, STAY AWAY FROM THE STEAM COMING OUT OF THE UNIT. THE STEAM CAN CAUSE BURNS.

## CONTROLS

Operator controls are on the front right of the unit. The control panel has the following touch pads and indicator lights. (Your controls may have either words or the symbols shown below):

 The ON/OFF touch pad gets the HyPerSteam ready for use, or shuts it off.

 The READY indicator light shows that the steam generator is at standby temperature and the cavity is hot enough to begin steaming.

 The CLEANING indicator lights when the unit is operating in the cleaning mode.

 The SERVICE indicator light shows when the water level probes have stopped working, and need to be cleaned (normally an indication of lime deposits). When one probe is not working, the SERVICE light flashes briefly every few seconds, but the unit continues to operate. De-lime the unit as soon as possible. If the problem continues, both probes may fail. Then the steamer stops working, the light will flash repeatedly and the beeper will sound. At this point you must turn off the power and contact an Authorized Groen Service Representative for repair.

 The HI TEMP indicator light comes on when the steam generator is too hot. The unit will automatically shut off, and cannot be turned on again until the steam generator cools and the HI TEMP light goes out.

 The TIMING indicator light stays on when the timer is running.

 The CLEAN touch pad is used to start the automatic 50 minute cleaning cycle.

The timer is used in three ways:

1. In the OFF position the steam generator stays at a low boil or “holding” temperature.
2. When a cook time is set, the unit steams until the timer reaches OFF. The steaming stops, a red light comes on and a beeper sounds.
3. With the timer turned to the ON position, the unit steams continuously. The green light stays lit. The steamer will not time down.

# Operation

**WARNING**  
WHEN YOU OPEN THE DOOR, STAY AWAY  
FROM THE STEAM COMING OUT OF THE  
UNIT. THE STEAM CAN CAUSE BURNS.



## OPERATING PROCEDURE

1. Press the ON switch/pad for the steamer. The steam generator will fill, and heat until the READY light comes on. (About 10 minutes.)
2. Load food into pans in uniform layers. Pans should be filled to about the same levels, and be even on top.
3. Open the door and slide the pans onto the supports. If you will only be steaming one pan, put it in the middle position.
4. Close the door. With the READY indicator lit, take one of the following steps:
  - If you want to steam the food for a certain length of time, set the timer for that period. The timer will automatically run the steamer for the set time and then turn it off. A red light will come on and a beeper will sound. Steam production stops.
  - To steam continuously, turn the timer to the manual ON position. A green light will come on. The unit will continue steaming until you stop it by turning the timer to OFF. When steaming continuously YOU MUST CONTROL STEAMING TIME.
5. Open the door. Remove the pans from the steamer, using hot pads or oven mitts to protect your hands from the hot pans.
6. To shut down the unit, press the ON/OFF touch pad to OFF. The steam generator will automatically drain.

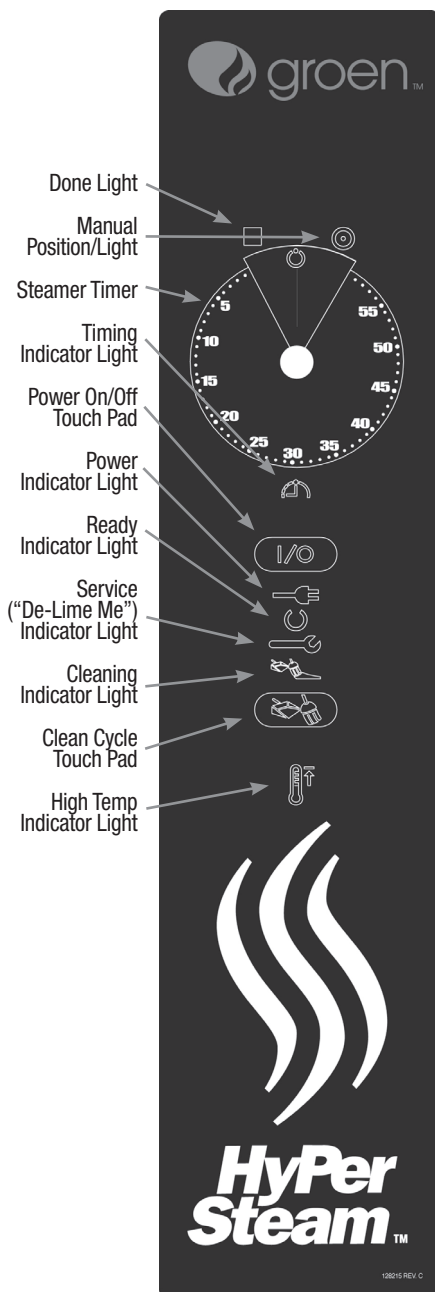

# Cleaning

**WARNING**  
DISCONNECT THE POWER SUPPLY BEFORE CLEANING THE OUTSIDE OF THE STEAMER.

KEEP WATER AND CLEANING SOLUTIONS OUT OF CONTROLS AND ELECTRICAL COMPONENTS. NEVER HOSE OR STEAM CLEAN ANY PART OF THE UNIT.

DON'T MIX DE-LIMING AGENTS (ACID) WITH DE-GREASERS (ALKALI) ANYWHERE IN THE UNIT.

AVOID CONTACT WITH ANY CLEANERS, DE-LIMING AGENT OR DE-GREASER AS RECOMMENDED BY THE SUPPLIER. MANY ARE HARMFUL. READ THE WARNINGS AND FOLLOW THE DIRECTIONS!

EVEN WHEN THE UNIT HAS BEEN SHUT OFF, DON'T PUT HANDS OR TOOLS INTO THE COOKING CHAMBER UNTIL THE FAN HAS STOPPED TURNING.

DON'T OPERATE THE UNIT UNLESS THE TWO REMOVABLE INTERIOR PARTITIONS HAVE BEEN PUT BACK IN THEIR PROPER LOCATIONS.

DON'T USE ANY CLEANING OR DELIMING AGENT THAT CONTAINS ANY SULFAMIC AGENT OR ANY CHLORIDE, INCLUDING HYDROCHLORIC ACID (HCl). TO CHECK FOR CHLORIDE CONTENT SEE ANY MATERIAL SAFETY DATA SHEETS PROVIDED BY THE CLEANING AGENT MANUFACTURER.

**IMPORTANT**  
DO NOT USE ANY METAL MATERIAL (SUCH AS METAL SPONGES) OR METAL IMPLEMENT (SUCH AS A SPOON, SCRAPER OR WIRE BRUSH) THAT MIGHT SCRATCH THE SURFACE. SCRATCHES MAKE THE SURFACE HARD TO CLEAN AND PROVIDE PLACES FOR BACTERIA TO GROW. DO NOT USE STEEL WOOL, WHICH MAY LEAVE PARTICLES IMBEDDED IN THE SURFACE WHICH COULD EVENTUALLY CAUSE CORROSION AND PITTING.



To keep your HY-3E or HY-5E Steamer in proper working condition, use the following procedure to clean the unit. This regular cleaning will reduce the effort required to clean the steam generator and cavity.

## SUGGESTED TOOLS

1. Mild detergent
2. Stainless steel exterior cleaner such as Zepper®
3. Steam generator de-liming agent, such as Groen Delimer Descaler. A liquid de-liming agent will be easier to use than crystals or powders. See the warning about chlorides.
4. De-greaser
5. Cloth or sponge
6. Plastic wool or a brush with soft bristles
7. Spray bottle
8. Measuring cup
9. Nylon pad
10. Towels
11. Plastic disposable gloves
12. Funnel

## PROCEDURE

### 1. Outside

- a. Prepare a warm solution of the mild detergent as instructed by the supplier. Wet a cloth with this solution and wring it out. Use the moist cloth to clean the outside of the unit. Do not allow freely running liquid to touch the controls, the control panel, any electrical part, or any open louver.
- b. To remove material which may be stuck to the unit, use plastic wool, a fiber brush, or a plastic or rubber scraper with a detergent solution.
- c. Stainless steel surfaces may be polished with a recognized stainless steel cleaner such as Zepper®.

### 2. Steam Generator and Cooking Chamber

The steamer cavity and steam generator may be cleaned separately. Regular de-liming, depending on your steamer usage and local water quality, must be done to enhance performance and prolong the life of your HyPerSteam™ convection steamer. Steamer must be turned off after every use to prevent lime scale buildup - do not run steamer continuously. When cleaning is scheduled, or the SERVICE light is on, follow the simple deliming instructions on the next page.

**NOTE:** ALWAYS USE HOT PADS OR MITTS WHEN HANDLING HOT STEAMER PANELS OR RACKS. DON'T ALLOW DE-LIMING AGENTS TO MIX WITH DEGREASERS.

#### RECOMMENDED TOOLS & CLEANERS:

- Groen Delimer/Descaler (Part Number 114800). Do NOT use any product containing chlorides or sulfamic acid, including hydrochloric acid.
- Nylon scrub pad, cloth and/or sponge.

# Cleaning

**CAUTION**  
NEVER LEAVE A CHLORINE SANITIZER IN CONTACT WITH STAINLESS STEEL SURFACES FOR LONGER THAN 30 MINUTES. LONGER CONTACT CAN CAUSE CORROSION.

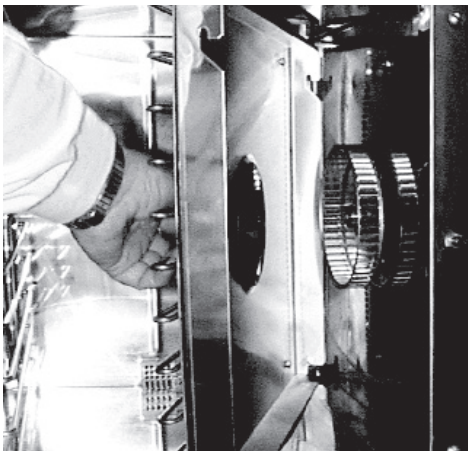

Once the cavity has cooled, reach in and remove the fan baffle partition by lifting it upward and drawing it toward the center of the cavity.

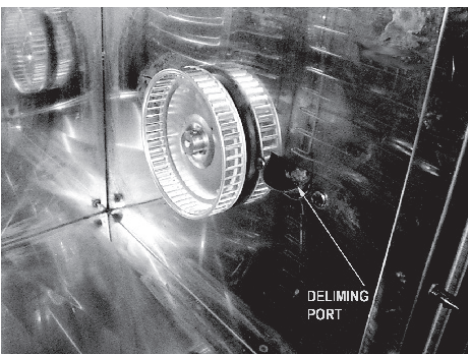

Pour two cups of Groen de-liming solution into the de-liming port.

## DE-LIMING STEPS (Use Touch Pad)

### STEP 1

Press ON/OFF to turn steamer off. Open door.

### STEP 2

Let cavity cool for 5 minutes or longer. While cool, wipe out cavity. Close door.

### STEP 3

Press and hold CLEAN while also turning steamer on by pressing ON/OFF, until only DELIME and POWER lights remain on (all lights will turn on, then off, except DELIME and POWER).

### STEP 4

After 5 minutes, beeper will beep rapidly, signaling you to add Groen Delimer/ Descaler. Door(s) must remain closed for entire delime cycle.

### STEP 5

Pour 1 pint (2 cups) of delimer PER CAVITY into upper and /or lower deliming port(s) and then close port(s). Press CLEAN. Double-stacked unit cavities may be delimed together or seperately

### STEP 6

Delime cycle will start, taking about 30 minutes. When delime cycle is complete, DELIME light will appear, DONE light will flash and beeper will beep.

### STEP 7

Press ON/OFF to turn steamer off. Let cavity cool for 5 minutes or longer. Open door, wipe out inside of cavity and wipe door gasket. Close door.

### STEP 8

To use steamer, press ON/OFF. When READY light appears, steamer is ready to use.

### NOTES:

- If DELIME light flashes rapidly (5 times per second), press DELIME to restart delime cycle.
- If power outage occurs during deliming, delime cycle must be restarted. Press DELIME.
- For best performance, do not interrupt delime cycle. If delime cycle must be stopped, press ON/OFF to turn on. Set timer for 5 minutes. After beeper beeps, press ON/OFF to turn off. Let cavity cool for 5 minutes or longer, carefully open door(s) and wipe out cavity completely.

# Maintenance

**NOTE**  
**THE UNIT CONTAINS NO FUSES THAT SHOULD BE REPLACED BY THE OPERATOR.**

HY-3E and HY-5E Steamers are designed for minimum maintenance, and no user adjustments should be necessary. Certain parts may need replacement after prolonged use. If there is a need for service, only Groen personnel or authorized Groen representatives should perform the work. Always supply water with a low mineral count that meets the standards outlined in the Water Conditioning section of this manual.

If steam or condensate is seen leaking from around the door, take the following steps:

1. Check the door gasket. Replace if it is cracked or split.
2. Inspect the cooking chamber drain to be sure it is not blocked.
3. Adjust the latch pin to allow for changes that might occur as the gasket ages.
  - a. Loosen the lock nut at the base of the latch pin. Turn the latch pin ¼ turn clockwise, and re-tighten the lock nut.
  - b. After adjustment, run the unit to test for further steam leakage.
  - c. If there is still leakage, repeat the adjustment.
  - d. Continue adjusting the pin clockwise until the door fits tightly enough to prevent leakage.

# Troubleshooting

This Groen Steamer is designed to operate smoothly and efficiently if properly maintained. However, the following is a list of checks to make in the event of a problem. Wiring diagrams are furnished inside the service panel. If an item on the check list is marked with (X), it means that the work should be done by a factory-authorized service representative.

SYMPTOM	WHO	WHAT TO CHECK
Steam generator does not fill with water.	User	a. Is the ON switch depressed? b. Is the water supply connected? c. Is the water turned on? d. Check for low water pressure (less than 30 PSI or 210 kPa) OR low water flow (less than 5.7 liters (1.5 gallons) per minute). e. Is the screen at the water connection clogged? f. Has the steam generator been delimed?
No steam.	User	a. Is the ON switch depressed? b. Is the water supply connected? c. Is the water turned on? d. Are steamer doors open? e. Is the steam generator limed up?
Service light comes on after four minutes.	User	a. Is the water supply connected? b. Is the water turned on? c. Has the unit been delimed? (Refer to Cleaning Section)
Excessive steam escaping from rear of unit.	User	a. Is the water spray hose kinked or obstructed?
	Authorized Service Rep Only	b. Is the water spray solenoid connected? X c. Is the drain properly vented? X
High Limit Indicator Light is "ON."	Authorized Service Rep Only	Reset the high limit thermostat after checking the cause of high temperature and correcting it. (X) (See Service Section)

# Parts List

## Model HY-3E (CE)

Key	Description	Part #
1a	RIGHT SIDE PANEL	123134
1b	LEFT SIDE PANEL	123135
2	DOOR ASSY, COMPLETE	094150
3	DOOR HANDLE	070123
4	DOOR GASKET	094147
5	LEFT PAN RACK	094148
6	BLOWER COVER/RACK	096788
7	DOOR LOCKING PIN	078914
8	DOOR PIN LOCK NUT	003823
11	CAVITY FAN	096790
12a	TIMER, 50 HZ	100983
12b	TIMER, 60 HZ	096826
13	TIMER KNOB	123100
17	MYLAR OVERLAY PLATE (UNIV. SYMBOLS)	128215
18	TOP PANEL	123133
19	FUSE BOX	-
19a	COVER, FUSE BOX	119846
20	BACK PANEL	125752
22	DRIP TRAY	094151
23	TIMER FASTENER NUT	101145
25	DIVERTER & VENT ASSY	123115
26	WATER INLET VALVE - 2 USED	071235
-	HEAT SHIELD	100934
-	OPTIONAL LEGS	118127
-	PC BOARD COVER	041121
-	EQUIPOTENTIAL TERMINAL*	119806
-	DRAIN KIT*	122021
-	WATER INLET ADAPTER ASSY*	127393
27	OPTIONAL STAND	122144

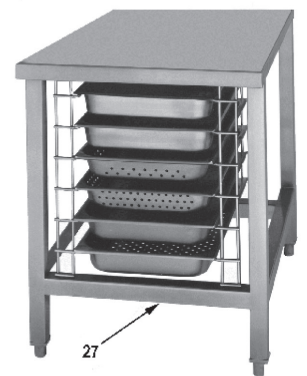
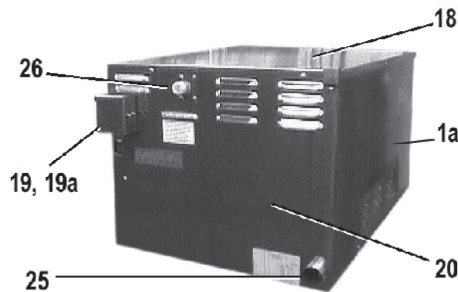

\*Item not depicted/called out in drawing or photographs

# Parts List

## Model HY-3E (CE)

Key	Description	Part #
1a	HEATER ELEM ASSY W/T-STAT 230V	128224
1b	HEATER ELEM ASSY W/T-STAT 400V	128224
1c	HEATER ELEM ASSY W/ OUT T-STAT 230V	123102
1d	HEATER ELEM ASSY W/OUT T-STAT 400V	123102
2	HEATER ELEMENT GASKET	042366
3	HI LIMIT THERMOSTAT	122009
4	FUSE, 6 AMP	119823
5	WATER LEVEL PROBES	070178
6	WATER VALVE DUAL SUPPLY	100934
7	TRANSFORMER 208/240V PRIMARY/24V SECONDARY 75VA	106234
8	TRANSFORMER 115/230V PRIMARY/20VAC CT SECONDARY	119815
9	HIGH HEAT CONTACTOR	119811
-	THERMOSTAT CLAMP*	093482

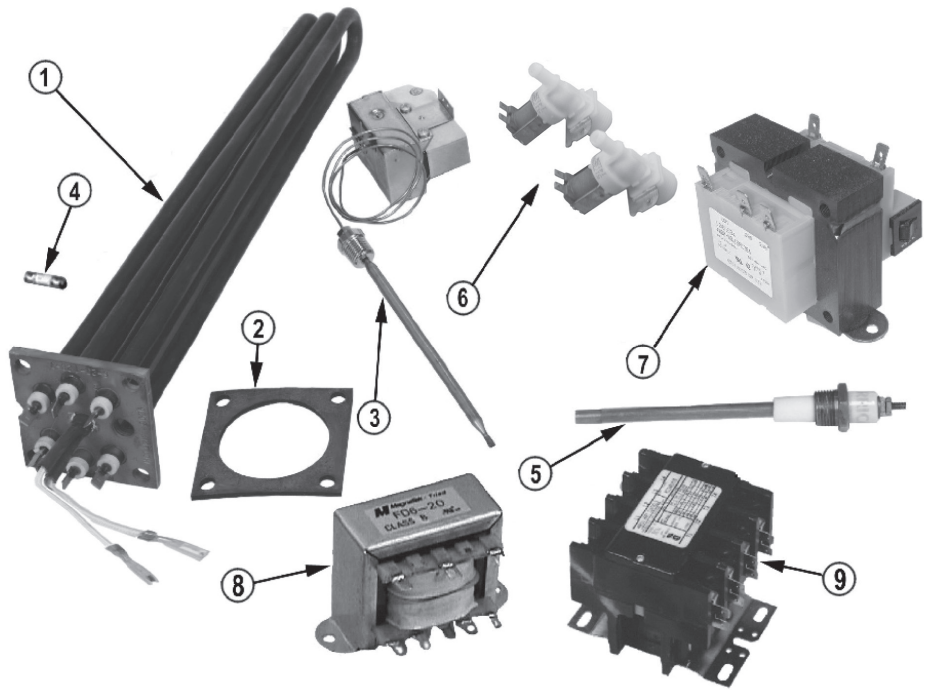

\*Item not depicted/called out in drawing or photographs



# Parts List

## Model HY-3E (CE)

Key	Description	Part #
1a	TIMER, 50 HZ	100983
1b	TIMER, 60 HZ	096826
2	DOOR SWITCH	096857
3	STEAM PORT	118103
4	STEAM PORT GASKET	099250
5	FAN MOTOR ASSEMBLY	096740
6	MOTOR SHAFT SEAL	096868
7	UPPER STEAM HOSE	123867
8	LOWER CLEAN HOSE	100926
9	HOSE CLAMPS 1-3/8"	127525
10	ELECTRIC HEATER GASKET	042366
11	TRANSFORMER 208/240V PRI. 24V SEC	106234
12	WATER LEVEL PROBES	070178
13	ELECTRIC HEATER, 230/400 VOLT	123102
14	HIGH LIMIT THERMOSTAT, MANUAL RESET	122009
15	STEAM GENERATOR	125707
16	INSULATION STEAM GEN- ERATOR	100922
17	FUSE BLOCK	096809
18	TERMINAL BLOCK	088214
19	MOTOR CAPACITOR	096813
20	READY THERMOSTAT	088865
21	6 AMP FUSES	119823
22	HIGH HEAT CONTACTOR	119811
23	TRANSFORMER, 115/230V PRI. 20V SEC.	119815
24	PC BOARD, STEAMER CONTROL	119801
25	PC BOARD, LIGHT & TIMER	119817
26	RELAY, 24 VOLT AC	119814
27	RELAY, 12 VOLT DC	119813
-	WATER SUPPLY INLET MOUNTING PLATE	101199
-	DRAIN VALVE*	071234
-	DRAIN VALVE BRACKET*	099991
-	DRAIN HOSE, STEAM GEN- ERATOR*	096806
-	CONDENSATE SPRAY HOSE*	096807
-	HARNESSES*-CALL GROEN AUTHORIZED SERVICE AGENT	-
-	CAVITY*	096825
-	CAVITY INSULATION*	096738
-	WATER FLOW REDUCER*	112720
-	STEAM GENERATOR W/ INSULATION & PROBES*	123199
-	PC BOARD COVER*	119806
-	WATER FILL HOSE*	096773
-	DRAIN KIT*	118948

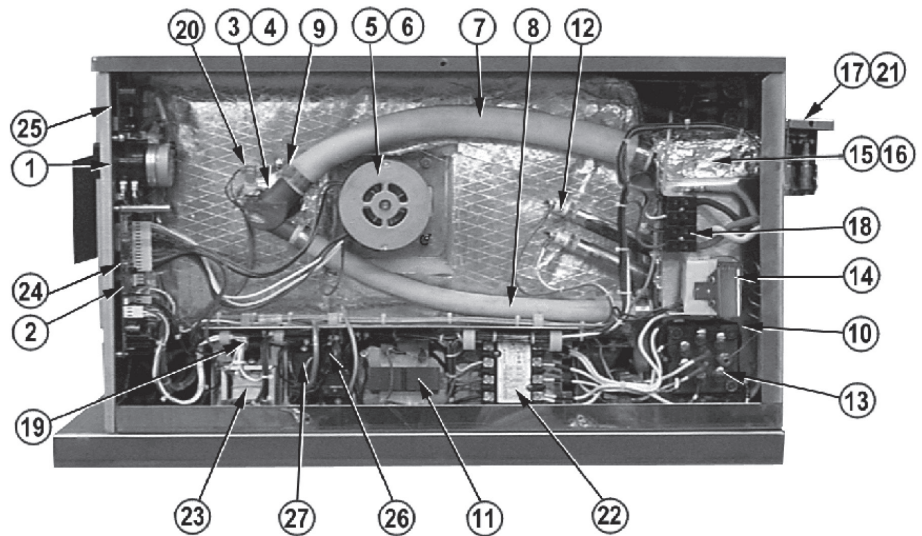

\*Item not depicted/called out in drawing or photographs

# Parts List

## Model HY-5E (CE)

Key	Description	Part #
1	LEFT PAN RACK	125901
2	DOOR ASSEMBLY, COMPLETE	125922
3	DOOR GASKET	125907
4	DOOR HANDLE	070123
5	DRIP TRAY	094151
6	TOP PANEL	123133
7	BLOWER COVER/RIGHT PAN RACK	125902
8	TIMER	100983
9	TIMER KNOB	123100
10	RIGHT SIDE PANEL	125930
11	DOOR LOCKING PIN	078914
12	DOOR PIN LOCK NUT	003823
13	MYLAR OVERLAY PLATE (INT'L SYMBOLS)	128403
14	WATER VALVE, DUAL SUPPLY	100934
-	WATER SUPPLY INLET MOUNTING PLATE	101199
-	WATER INLET ADAPTER ASSY (3/4 BSPT)	122144
15	BACK PANEL	125981
16	LEFT SIDE PANEL	125931
17	DIVERTER AND VENT ASSY	125918
-	DRAIN VALVE	071234
-	BRACKET, DRAIN VALVE	099991
-	EQUIPOTENTIAL TERMINAL ASSY	122021
-	DRAIN KIT	128237
-	WATER VALVE COVER PLATE DUAL SUPPLY	101199
-	GROEN DE-LIMER/DE-SCALER	114800

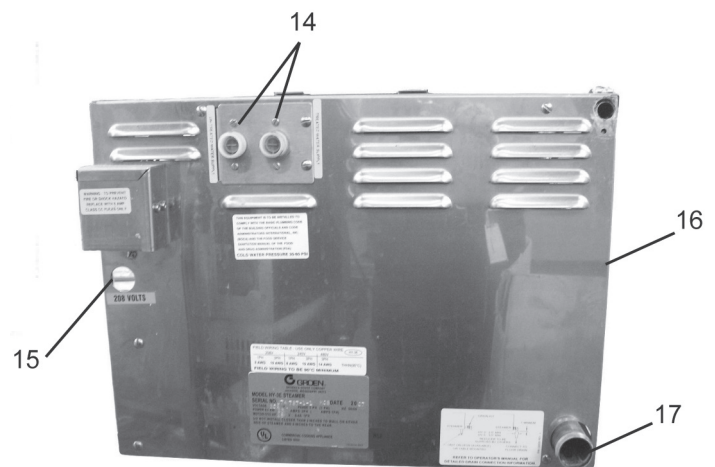

\*Item not depicted/called out in drawing or photographs

# Parts List

## Model HY-5E (CE)

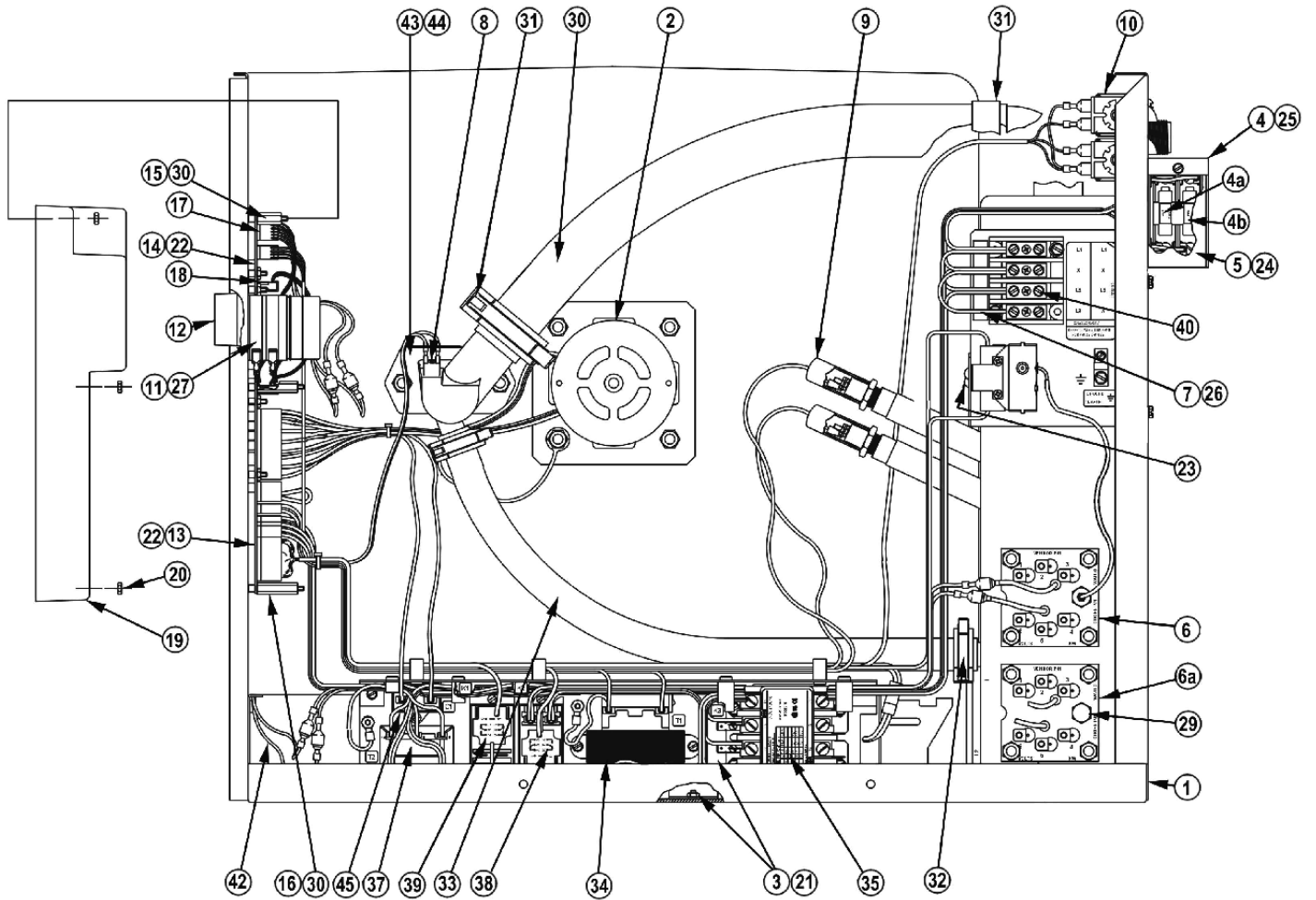

# Parts List

## Model HY-5E (CE)

Key	Description	Part #
1	PLATFORM ASSEMBLY	125967
2	FAN MOTOR ASSEMBLY	096740
3	CHASSIS ASSEMBLY, ELECTRICA	119852
4	FUSE BLOCK ASSEMBLY	119848
4a	FUSE HOLDER	096809
4b	FUSE, 6 AMP	119823
5	COVER, FUSE BOX	119846
6	HEATER ELEMENT ASSEMBLY WITH THERMOSTAT 230/400V	128224
6a	HEATER ELEMENT ASSEMBLY WITHOUT THERMOSTAT 230/400V	123102
6b	HEATER ELEMENT GASKET	042366
7	LINE CONNECTION ASSEMBLY	128395
8	READY THERMOSTAT	088865
9	PLASTISOL BOOT	101143
10	KIT, VALVE WATER INLET ASSEMBLY, DUAL SUPPLY	088816
11a	TIMER, STEAMER, 50 HZ	100983
11b	TIMER, STEAMER, 60 HZ	096826
12	KNOB, TIMER	123100
13	STEAMER CONTROL PC BOARD	119801
14	LIGHT & TIMER PC BOARD	119817
15	STANDOFF, HEX M-F 6-32 X 3/4	119826
16	STANDOFF, HEX M-F 6-32 X 1-1/4	119827
17	HARNESS, TIMER MOTOR	123120
18	JUMPER, CTRL BD TO DISPLAY BD	123122
19	COVER, CONTROL PANEL	119806
20	NUT, KEPS, 6-32	071289

Key	Description	Part #
21	NUT, KEPS 10-32	071256
22	NUT, LOCK NYLON INSERT 6-32	119855
23	SCREW, RD HD SELF-TAPPING 6-32 X 3/8	012398
24	SCREW SLOT HEX WASHER 8-32 X 1/4	074242
25	SCREW SLOT HEX WASHER 8-32 X 1/2	009696
26	PHASE, WIRE FOR TERMINAL BLOCK	094155
27	NUT, ROTARY SHAFT SEAL (TIMER)	101145
29	PLUG, PIPE 1/4 NPT 304 SS	004145
30	HOSE 1-1/2 ID X 20"	088846
31	CLAMP, CONSTANT TENSION 1-3/4"	126011
32	CLAMP, CONSTANT TENSION 1"	127524
33	HOSE, CLEAN, 18"	125954
34	TRANSFORMER 208/240 V	106234
35	HIGH HEAT CONTACTOR	119811
37	TRANSFORMER 20 V AC CT	119815
38	RELAY, 24 V AC	119814
39	RELAY, 12 V DC	119813
40	TERMINAL BLOCK	119850
42	DOOR SWITCH (TWO USED)	096857
43	STEAM PORT	125988
44	STEAM PORT GASKET	099250
45	MOTOR CAPACITOR	096813
-	WATER FILL HOSE*	125993
-	STEAM GENERATOR WITH INSULATION, PROBES, RELIEF VALVE & FITTINGS*	125938
-	MOTOR SHAFT SEAL*	096868
-	CONDENSATE SPRAY HOSE*	125994
-	WATER FLOW REDUCER*	088877

\*Item not depicted/called out in drawing or photographs

# Electrical Schematic

## Model HY-3E (CE)

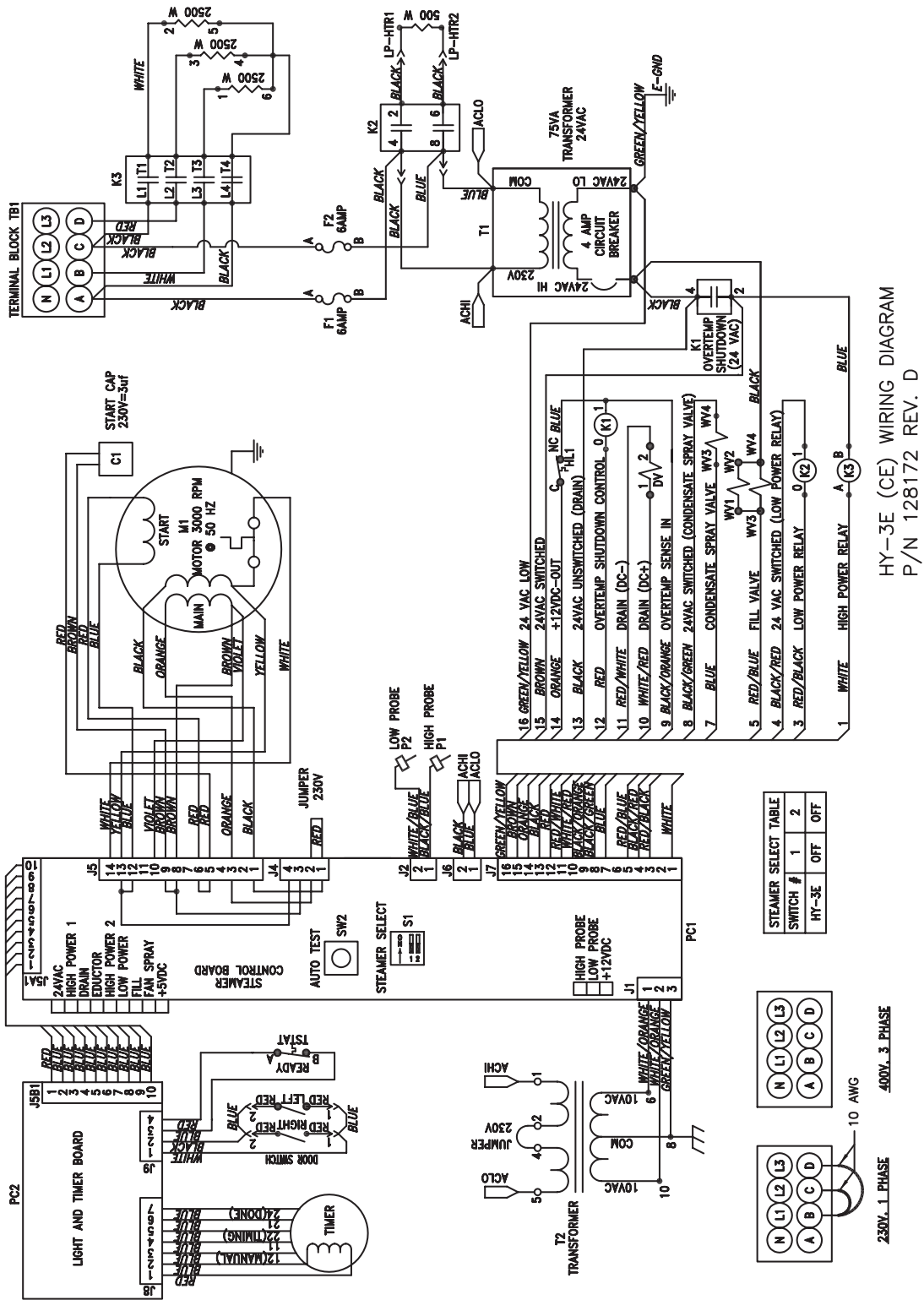

# Electrical Schematic

## Model HY-5E (CE)

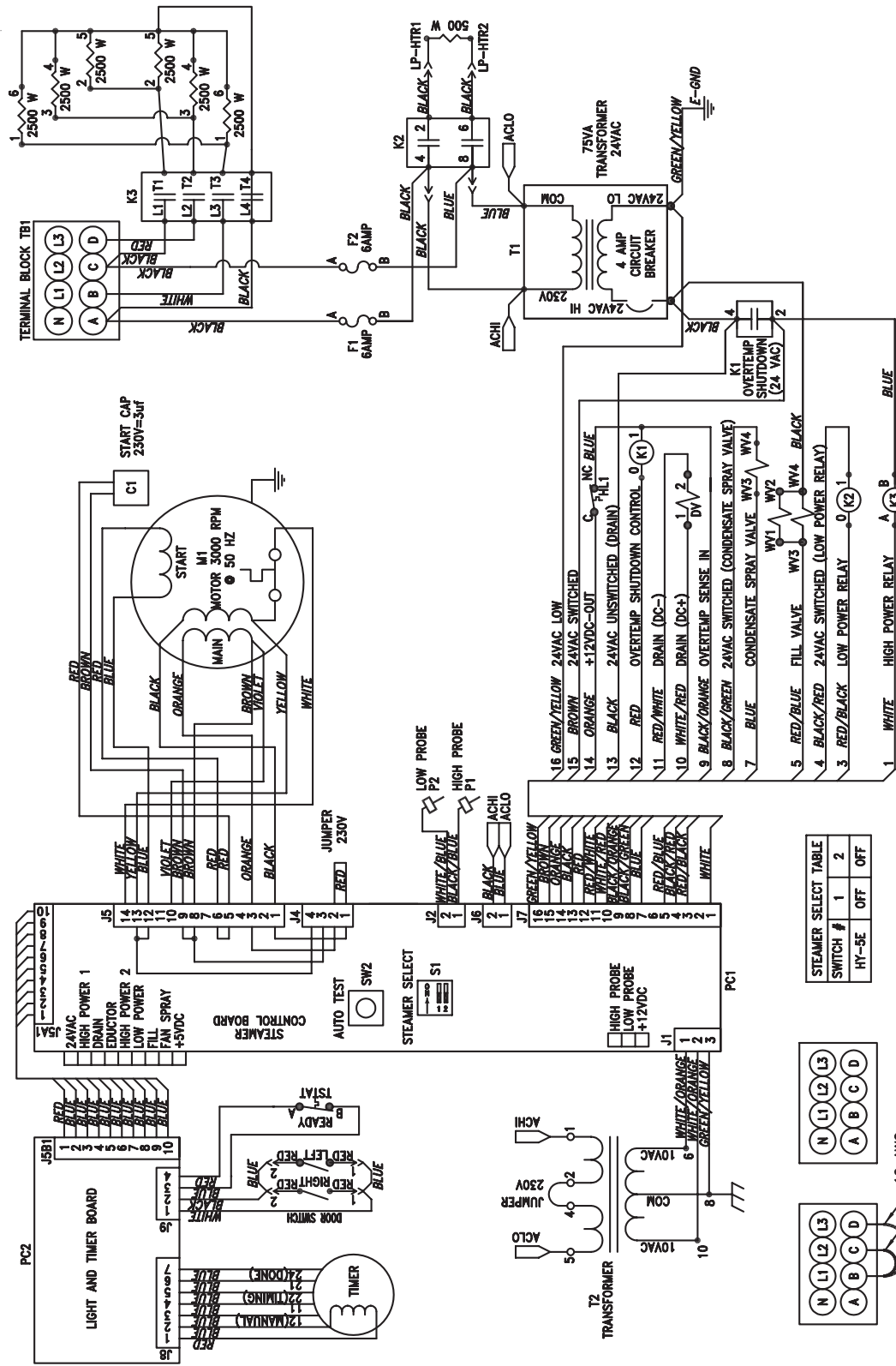

HY-5E (CE) WIRING DIAGRAM  
P/N 128228 REV. C

230V. 1 PHASE      400V. 3 PHASE

# Service Procedures

## [FOR PROFESSIONAL TECHNICAL SERVICE PERSONNEL ONLY]

**WARNING**  
THERE IS HIGH VOLTAGE INSIDE CONTROL COMPARTMENTS. DISCONNECT UNIT BEFORE SERVICING. FAILURE TO DO SO CAN RESULT IN SERIOUS INJURY OR DEATH.



### GENERAL INFORMATION

The following procedures are based upon having access to the steamer on all four sides. If the steamer is installed between other appliances and there is not enough room on the sides for access, the steamer must then be pulled out from its position to gain proper access.

Care should be taken in moving the steamer so as not to stress or pull on the electrical or water connections.

**NOTICE:** Refer to the Electrical Schematic Diagram and the Interconnect Diagram to identify and/or confirm terminal designations or wire colors.



#### 1. Side Panel - Removal (P/N 123134 - Right Panel, P/N 123135 - Left Panel)

- With a flat blade screw driver remove two 10-32 screws on the lower edge and one on the top edge of the panel. The panel is retained to the steamer by spring-like clips at the rear edge.
- Once the screws are removed SLIDE the panel towards the front. Do not attempt to PRY the panel. Once the panel is free of the rear clips, it may be lifted off the top track.

**ASSEMBLY TIP:** When replacing the panel, press the rear edge inward so that all three clips will be retained by the back flange. Make sure that the holes in the panel are in alignment with the tapped holes in the steamer so that the replacement of the three screws will be easy and not damaging.

#### 2. Top Panel - Removal (P/N 096777)

In order to replace the water drain valve, the condensate spray nozzle, alternate door switch location, or the steam generator, the top and left side of the steamer external cabinet must be removed. The following procedures are to be used:

- First, remove the side panel as described in Section 1.
- Remove the retaining bracket which prevents the top from sliding forward.
- The top and side assembly may then be slid forward and once clear of the retaining clips, may be lifted off.

**ASSEMBLY TIP:** In replacing the top panel assembly, make sure that the retaining clip is replaced and screwed down tight.



#### 3. Support Table (Optional) (P/N 100913)

- The steamer is supported on a stainless steel table. The steamer is attached to the table by four 1/2" bolts fastened from below.
- To remove the steamer from table, disconnect electric, water and drain lines from the steamer. Then remove the four bolts.
- Each leg is provided with a screw type support post. These may be extended or retracted by turning them with a wrench or ChannelLock. Make sure that all four legs are in tight contact with the floor for proper steamer support.
- If damaged, these posts may be replaced by tapping out (on opposites sides of the leg) the threaded fitting which is friction held in each stainless steel leg. The stainless steel leg Optional Support Table and the threaded fitting are one assembly.

# Service Procedures

## [FOR PROFESSIONAL TECHNICAL SERVICE PERSONNEL ONLY]

**WARNING**  
DISCONNECT THE POWER SUPPLY BEFORE BEGINNING ANY SERVICE PROCEDURE.

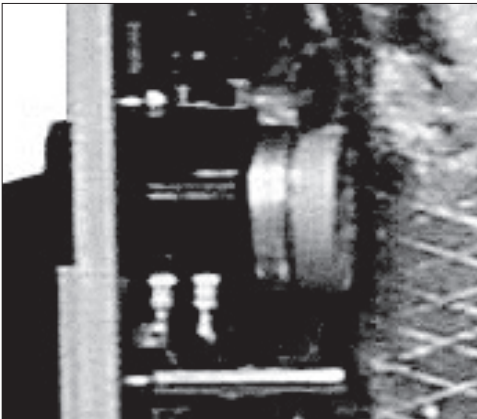

Timer Assembly

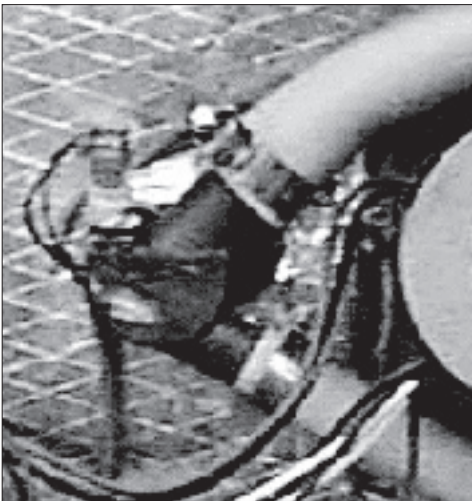

Steam Port and Ready Thermostat

The following parts, devices and assemblies may be inspected, tested and/or replaced with only the removal of the right side cover panel:

#### 4. Timer Assembly (P/N 100983 or 096826) Timer Fastener Nut (P/N 101145)

- Shut off power to the steamer. Remove the knob from the timer. Under the knob is a hexagonal nut which holds the timer mechanism to the steamer. Note that there is a flat on the timer shaft which corresponds to a frictional mounting hole on the knob.
- From the left side, unplug the five terminals/ wires (violet, gray, black, tan and white) from the timer mechanism and unplug the two black timer motor leads.
- With a 1/2" open ended wrench, remove the hex nut holding the timer in place. The timer may then be removed from inside the compartment.
- **NOTE:** Right below the timer shaft, the timer has a small plastic disk molded into the case. There is a corresponding hole punched into the front panel. This hole may be seen from the inside of the compartment only when the timer is removed.

To Install:

- Fit the timer in place making sure that it is properly placed so that the disc on the timer fits into the punched hole in the front panel.
- Once the timer is properly located, tighten the hex nut so that the timer does not slip or rotate. Do not over tighten the nut.
- Align the flat of the knob hole with the flat on the timer shaft. Press the knob firmly onto the timer shaft.
- Plug in the wires identified above and connect the two black wires from the motor leads.

#### 5. Steam Generator Ready Thermostat (P/N 099947)

Thermostat is attached to the steam port by two 6-32 screws.

- Turn off power to the steamer.
- Unplug the two wires from the thermostat from the wiring harness.
- Using a flat blade screwdriver, remove the two 6-32 screws holding the thermostat to the steam port.

To Install:

- To install a new thermostat, use a small amount of heat sink compound (1 drop), applied to bottom of thermostat. Seat the thermostat on the steam port and fasten with the two screws (as above). Apply heat sink compound to the threads of 6/32 screws to prevent leaks.
- Plug the thermostat into the wiring harness.

#### 6. Steam Port (P/N 118103 (3E) & P/N 125988 (5E)) Gasket (P/N 099250)

- Turn off the power to the steamer.
- Remove the large steam hose by loosening the hose clamp with a 5/16 inch nutdriver and then removing the hose from the steam port collar.
- Remove the 3/4 inch clean hose by loosening its hose clamp with a 5/16 inch nutdriver and then removing the hose from the steam port collar.
- With a flat blade screwdriver, remove the two 6-32 screws which hold the thermostat to the steam port.
- With a sharp knife or scissor, cut the foil thermal blanket. Then fold back the foil blanket to reveal the two 1/4-20 kee nuts, which hold the steam port to the cavity wall.



# Service Procedures

## [FOR PROFESSIONAL TECHNICAL SERVICE PERSONNEL ONLY]

**WARNING**  
DISCONNECT THE POWER SUPPLY BEFORE  
BEGINNING ANY SERVICE PROCEDURE.

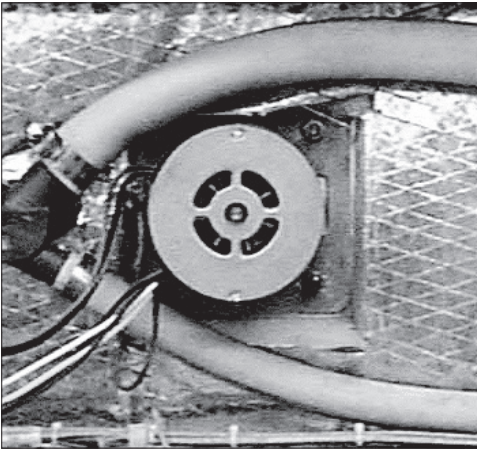

Steam hose is mounted above the fan motor, clean hose is mounted below.

- With a 7/16 inch nutdriver remove the two kep nuts.
- Remove the steam port from the threaded studs.

To Install:

- Apply RTV Clear Silicone Sealant to the groove of the steam port (or use gasket P/N 099250), then insert the steam port on the two threaded studs and fasten the two kep nuts with a 7/16 inch nutdriver. Wipe away excess sealant from the cavity.
- Mend the foil thermal blanket, where cut, with aluminum foil duct tape.
- Fasten the thermostat with two 6-32 screws. Apply heat sink compound to the bottom of thermostat and to the threads of the screws to prevent leaks. See Section 5.
- Install the 3/4 inch clean hose on the steam port and fasten with hose clamp.
- Install large steam hose to steam port and fasten with hose clamp.

### 7. Cavity Hose Assembly:

**Steam Hose (HY-3E) (P/N 123867)**

**Steam Hose (HY-5E) (P/N 126008)**

**Clean Hose (HY-3E) (P/N 101641)**

**Clean Hose (HY-5E) (P/N 125954)**

There is one steam hose installed over the motor connecting the steam generator to the cavity. There is a clean hose installed under the motor which connects the steam generator with the cavity. Either hose may be replaced using the following method:

- Shut off power to the steamer.
- Using a 5/16 inch nutdriver, loosen the hose clamp where the hose is attached to the steam port. Turn and pull the hose to remove it from the hose collar.
- Using a 5/16 inch nutdriver, loosen the hose clamp where the hose is connected to the steam generator. Turn and pull the hose to remove it from the hose collar.
- The hose may be removed.

**IMPORTANT.** Make sure that the correct part (and part number) is being used. The hoses are similar in appearance but are not the same!

Install steam hose over the motor. The clean hose must be installed under the motor to allow cleaning liquids to enter the generator.

To Install:

- Slide the two hose clamps onto the hose and position the hose adjacent to the steam port and steam generator.
- Slide the hose onto the hose collar on the steam port and at the other end, onto the steam generator collar. Make sure the hose is on all the way so that the end of the hose is against the face of the collars.
- Slide the hose clamps down so that they are about 1/8 inch from the end of the hose (at both ends) and using a 5/16 inch nutdriver, tighten the hose clamps.

**NOTE:** Over tightening of hose clamps may cut the hoses.

# Service Procedures

## [FOR PROFESSIONAL TECHNICAL SERVICE PERSONNEL ONLY]

**WARNING**  
DISCONNECT THE POWER SUPPLY BEFORE BEGINNING ANY SERVICE PROCEDURE. EVEN WHEN THE UNIT HAS BEEN DISCONNECTED, DO NOT PUT HANDS OR TOOLS INTO THE COOKING CHAMBER UNTIL THE FAN HAS COMPLETELY STOPPED TURNING.

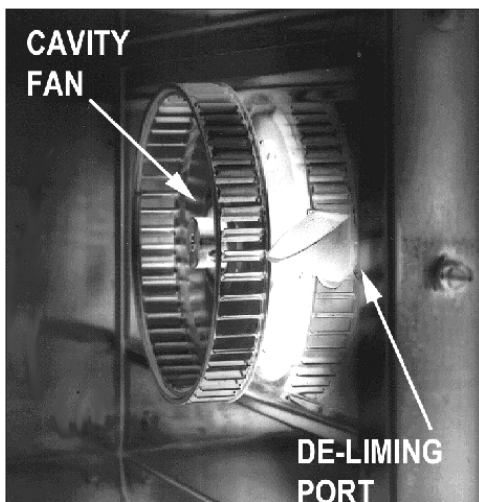

Cavity Fan

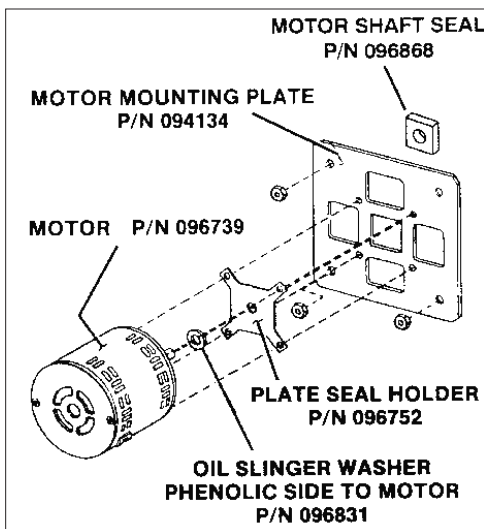

Fan Motor Assembly Diagram

### 8. Fan (P/N 096790)

**IMPORTANT:** Make sure fan has come to a complete stop before working on it.

- To remove the fan from the cavity, open the door and remove the pan support wire rack from in front of the fan.
- With a 1/8 inch Allen wrench, loosen the set screw which holds the fan to the motor shaft.
- Hold onto the fan, and with a slight rocking motion pull the fan off the motor shaft.

To Install:

- Note that the motor shaft has a flat surface. Position the fan hub on the motor shaft so that the 1/8 inch Allen set screw is opposite the flat portion of the motor shaft.
- Slide the fan onto the motor shaft far enough so that the motor shaft is at the end of the fan hub.
- With a 1/8 inch Allen wrench, tighten the set screw on the fan.

**NOTICE:** Advise customer to clean the fan blades periodically of deposited food grade grease coming from the foods being cooked. The deposit of such grease over time could cause the fan blades to vibrate.

### 9. Fan Motor Assembly (P/N 096740)

**Motor Shaft Seal (P/N 096868)**

**Motor Insulator (P/N 094135)**

**Oil Slinger Washer (P/N 096831)**

- Shut off electrical power to the steamer.
- From inside the cavity, remove fan using a 1/8 inch Allen wrench as shown in Section 8.
- Using a 7/16 inch nutdriver/socket, remove the four 1/4-20 kep nuts holding the motor. Note that one of the nuts secures the motor ground strap to the steamer.
- Remove the motor mounting plate to which the motor is attached.

To Install New Motor:

- Make sure the motor insulation board is installed on the four threaded studs to the cavity wall
- Apply Never-Seez on both sides of the steamer motor seal and the inside hole. Refer to the Motor Assembly Diagram.
- Insert the steamer motor seal in the cutout of the insulator board.
- To prepare motor for mounting, slide the oil Slinger washer onto the shaft about 1/2 inch down the shaft. **IMPORTANT:** This washer has two surfaces: A rubber surface and a phenolic surface. Make sure the phenolic surface is facing the motor.
- Install the plate seal holder onto the motor shaft. Carefully slide the plate seal holder down the motor shaft until it engages the slinger washer. Continue moving the plate seal holder down the motor shaft until the plate comes to rest on the raised bosses of the motor casting.
- Using this technique, the rubber side of the oil slinger washer should be in contact with the plate holder and there should be a space of approximately 1/16 inch between the phenolic face of the washer and the motor.

# Service Procedures

## [FOR PROFESSIONAL TECHNICAL SERVICE PERSONNEL ONLY]

**WARNING**  
DISCONNECT THE POWER SUPPLY BEFORE BEGINNING ANY SERVICE PROCEDURE.

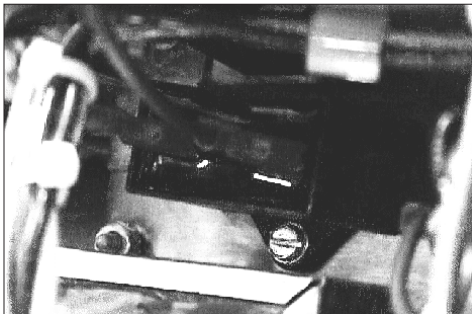

Fan Motor Capacitor

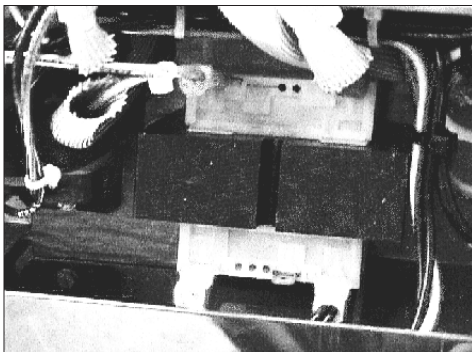

Control Transformer

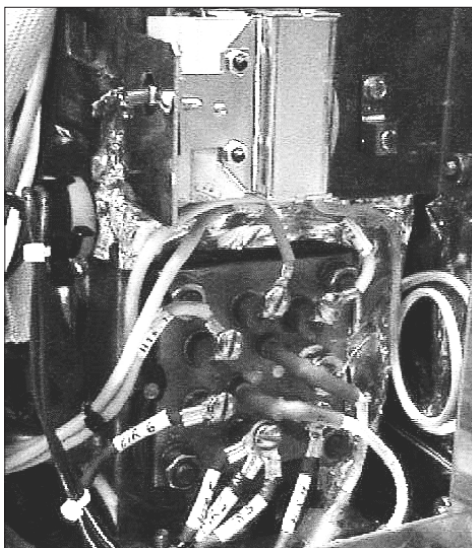

Electric Heater Assembly - High Limit  
Thermostat Switch Box Mounted Above

- Using four hex/slotted 6-32 screws, screw the motor mounting plate to the motor with each screw passing through corresponding holes in the plate seal holder.
- The entire assembly may now be positioned on the four threaded stud bolts protruding from the cavity wall. Fasten the assembly with the 1/4-20 kep nuts using a 7/16 inch nut driver. Make sure that the green ground strap is fastened by one of the kep nuts securing the motor.

### 10. Motor Starting Capacitor (P/N 096813)

- Turn off electrical power to the steamer.
- Loosen the two screws holding the motor capacitor.
- Unplug the two terminal wires from the capacitor. Remove the capacitor.

**NOTICE:** Make sure that the correct value of capacitor is used, which is 3  $\mu$ fd with a 330 volt rating.

### 11. Control Transformer (P/N 106234)

- Turn off power to the steamer.
- Note the position and identity of the terminals and then remove them from the control transformer.
- With a 5/16 inch nutdriver, remove the four 10-32 screws holding the control transformer to the service tray. **NOTE:** Do not lose lock washers at the ground wire.
- Remove control transformer from the service tray.

To Install:

- Install the control transformer in the service tray.
- Fasten the control transformer to the service tray with four 10-32 screws using a 5/16 inch nutdriver. **NOTE:** Ground terminal between lock washers.
- Reattach terminals to control transformer.

### 12. Gasket (P/N 042366)

#### Heater Element (P/N 123102 - 240 Volt)

#### High Limit Thermostat (P/N 122009)

- Turn off all power to the steamer.
- Remove the six terminals and two plugs from the heating element.
- With a 1/2 inch socket wrench, remove the four nuts and lockwashers holding assembly to generator.
- Carefully slide the assembly about 2 inches out of the steam generator.
- Remove the two 6-32 self tapping sheet metal screws from the underside of the thermostat switch.
- Remove the two terminal wires attached to the thermostat Electric Heater Assembly switch.
- Remove the gasket attached to the steam generator and discard. Remove heater and thermostat assembly.
- The thermostat bulb is fastened to one of the heater elements by two small hose clamps or metal straps.
- Remove the clamps or straps holding the thermostat bulb to the heater.
- With a 9/16 inch open-ended wrench, loosen the capillary fitting for the thermostat.
- Remove the probe, capillary and thermostat bulb as an assembly.

# Service Procedures

## [FOR PROFESSIONAL TECHNICAL SERVICE PERSONNEL ONLY]

**WARNING**  
DISCONNECT THE POWER SUPPLY BEFORE BEGINNING ANY SERVICE PROCEDURE.

**CAUTION**  
DO NOT DAMAGE HEATER OR CRACK THE CERAMIC SPACERS.

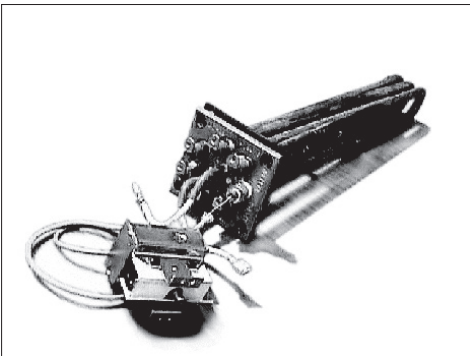

Heater Assembly and High Limit Thermostat

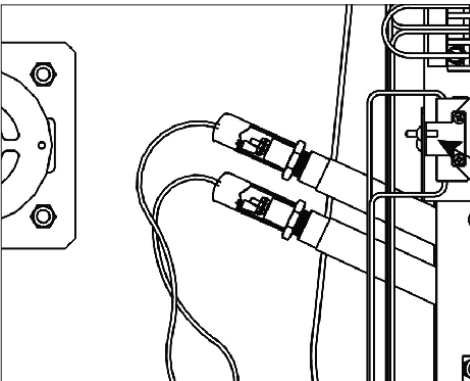

High and Low Water Steam Generator Probes

To Install:

- Clamp thermostat bulb to the Number 2 Heater Rod.
- Apply pipe compound to the thread and tighten the compression fitting around the capillary in the threaded hole provided for this fitting.
- Install a new gasket on the steam generator.
- Insert the entire assembly into the steam generator. There is an orientation pin so that the assembly can only be installed one way. The pin is on the left of the steam generator. When properly installed, terminals 1, 2 and 3 are on top.
- Reconnect the terminal wires to the heater. Install thermostat switch to bracket with sheet metal screws.
- Attach bracket over the two upper threaded studs before installing nuts.
- Install four nuts and lockwashers on threaded studs, and tighten with a 1/2 inch socket wrench.

### 13. High Limit Thermostat (Steam Generator) (P/N 122009) Stainless Steel Clamp (P/N 093482)

To Reset:

- Press red reset button once.

To Remove:

- Shut off electrical power to the steamer.
- Remove the heating elements from the steam generator in accordance with directions provided in Section L.
- Using a 7mm nutdriver, loosen two stainless steel hose clamps holding the thermostat bulb to the heater element.
- With a 9/16 inch open ended wrench, unscrew the thermostat bulb from the heater plate.

To Install:

- Apply high temperature pipe compound to the threads of the new thermostat fitting. Screw the thermostat fitting into the heater plate. Tighten with a 9/16 inch open ended wrench
- Position the thermostat bulb on top of heater coil No. 2 (center heater)
- Position the two stainless steel hose clamps around BOTH the heater coil and the thermostat bulb. Tighten using a 7mm nutdriver.
- Tighten the compression nut on the heater plate using a 5/16 open ended wrench.

### 14. Steam Generator Probes (High and Low Water) (P/N 070178)

- Turn off power to the steamer.
- Remove right side panel.
- Slide back the rubber “boots” covering the probe terminals to expose the terminals wires.
- With a 5/16 inch nutdriver LOOSEN, but do not remove the nuts holding the wire(s) on the probe terminal(s).
- The wires are connected to wire fork terminals. These will “snap” on and off the terminal post. “Un-snap” them by gently pulling on the terminal.
- Using a 13/16 inch open ended wrench, turn the probe counter-clockwise to remove. Clean or replace.

# Service Procedures

## [FOR PROFESSIONAL TECHNICAL SERVICE PERSONNEL ONLY]

**WARNING**  
DISCONNECT THE POWER SUPPLY BEFORE BEGINNING ANY SERVICE PROCEDURE.

**CAUTION**  
DO NOT DAMAGE HEATER OR CRACK THE CERAMIC SPACERS.



Heater Assembly and High Limit Thermostat

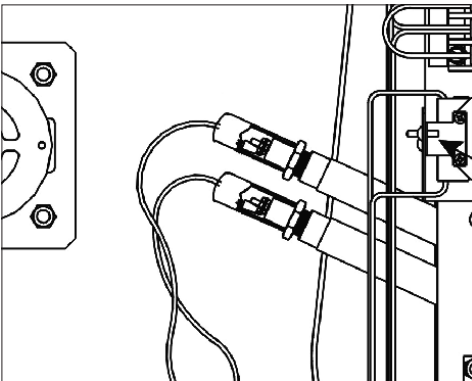

High and Low Water Steam Generator Probes

To Install:

- Apply high temperature pipe compound to the probe and screw it in by hand. Using a 13/16 inch open ended wrench, tighten the probe into the fitting.
- Replace the wire(s) to the probes by snapping the fork terminals around the terminal post. Using a 5/16 inch nutdriver, tighten the terminal nut.

**NOTE:** If two probes are to be replaced, either replace them one at a time or note the color of the wires attached to the probes. Do not mix them up.

### 15. Water Inlet Valve - Two Provided (P/N 100934)

- Turn off power to the steamer. Turn off the water supply to the steamer. Remove the water supply hose connection on the rear of the steamer.
- Remove the two 10-32 truss head screws holding the valve support plate to the rear of the steamer.
- Remove the plate with the valve attached.
- Once the valve is outside the steamer cabinet, note the position and identity of the terminals and remove the four terminals to the valve.
- With a 7mm nut driver, loosen the two hose clamps connected to the valve and remove the clear Tycon water hose and the black condensate spray hose from the valve.
- Remove the two 8 -32 screws holding the valve to the plate, and remove valve.

To Install:

- Fasten the new valve to the support plate using two 8-32 screws.
- Attach the waterfill clear hose to the bottom outlet of the valve with the hose clamp.
- Attach the condensate spray hose to the top outlet of the valve with the hose clamp. **IMPORTANT:** Do not over tighten the hose clamps as this may cut the hose.
- Attach the four terminals to the valve.
- Tip the plate into position and fasten plate to rear of the steamer cabinet with the two 10- 32 truss head screws.

### 16. Steam Generator Drain Valve (P/N 071234)

- Turn off power and disconnect steamer from branch circuit. Remove right side panel and top left side/cover.
- With a 5/16 inch nutdriver, remove the two 10-32 screws holding the valve bracket to the steamer base on right side of unit.
- The steam generator drain valve is located UNDER the cavity and all work should be done from the left side of the steamer (as viewed from the front).
- Using a 7mm nutdriver or spring clamp pliers, disconnect ONE END of the drain hose by loosening the drain hose clamp from the drain elbow coming from the cavity drain. Remove clamp.
- Unplug and disconnect the valve electrical wires.
- Slide the valve support bracket out from under the steam generator with the valve attached to it. Allow the silicone hose to leave the valve.
- Remove the two 10-32 screws from the valve bracket, then remove valve from the bracket.

# Service Procedures

## [FOR PROFESSIONAL TECHNICAL SERVICE PERSONNEL ONLY]

**WARNING**  
DISCONNECT THE POWER SUPPLY BEFORE  
BEGINNING ANY SERVICE PROCEDURE.



To Install:

- Attach new drain valve to valve bracket. Pull silicone hose through drain valve and install hose clamp over one end of the exposed hose and attach hose to drain elbow.
- Install and tighten valve mounting bracket with two 10-32 screws. Be sure silicone hose is properly aligned and does not have any kinks, bends and/or twists in it.
- Plug the electrical leads of the valve into the wiring harness. Connect steamer to branch circuit, and turn on power.

To Test:

- Operate steamer and allow steam generator to fill. Check for leaks and observe if drain valve fully closes. Turn off steamer and observe that drain valve opens and the steam generator drains.
- Reinstall top/left side cover.

### 17. Steam Generator (P/N 096836)

- Shut off power to the steamer, drain steam generator of all water. Remove right side panel and top/left side cover.
- Remove the bracket of the high limit thermostat switch and remove the two wires which connect the unit to the wiring harness. Leave thermostat attached to steam generator.
- Remove the two 8-32 screws which hold the water fill valve mounting plate to the steamer back.
- Remove back panel by removing the six 10- 32 truss head screws
- Using a small adjustable wrench, remove the drain hose brass compression nut.
- Using a 5/16 nutdriver, loosen the clamps holding steam and cleanout hoses. Detach hoses from generator.
- Remove the two water level probe terminals as indicated in Section N.
- Loosen hose clamp for drain hose under cavity in order to gain access to the two 1/4- 20 kep nuts on the left side of the steam generator.
- With an adjustable wrench, loosen the clamp holding the water inlet hose to steam generator. Remove hose from steam generator.
- Remove the four 1/4-20 kep nuts holding the steam generator in position.
- Remove steam generator from rear of steamer by lifting steam generator up and out.

To Install:

- Transfer all fittings, heater element, safety valve, high and low water level probes to new steam generator from old generator or use new fittings as needed. Refit the insulation on generator.
- Carefully wrap the thermal blanket onto the steam generator. Make sure it fits snugly, with no air spaces between the blanket and the steam generator. Fasten seams with aluminum duct tape.
- Fit the steam generator into position from the back of the steamer. Fasten the steam generator using the four 1/4-20 kep nuts.
- Connect all hoses to the steam generator fittings and tighten their respective hose clamps.
- Connect the probe terminals to the high and low level probes. Make sure the rubber boots are securely positioned on the terminals after connection.
- Connect the high temperature thermostat housing to the steamer bracket.

# Service Procedures

## [FOR PROFESSIONAL TECHNICAL SERVICE PERSONNEL ONLY]

**WARNING**  
DISCONNECT THE POWER SUPPLY BEFORE  
BEGINNING ANY SERVICE PROCEDURE.



### 18. Door Removal/Installation/Alignment (P/N 094150)

- To remove the door, turn off the steamer power and allow it to cool. Then, remove door by supporting the weight of the door and remove hinge pin.
- Place the door on a flat, clean table or similar support, with Steamer Door gasket facing up. Be careful not to scratch door surface.
- Inspect door gasket for signs of cuts or other defects which may impair its function. Replace if necessary. See Section 21.

To Install:

- To install the door, apply NEVER-SEEZ lubricant to hinge pin. Align door with hinge and insert hinge pin, or apply service removable Loctite 242 to the door-to-hinge bolts, then install door and mounting bolts. Do NOT tighten mounting bolts at this time.
- Place a piece of masking tape over the door pin (bullet) hole in the door/U-channel.
- Close the door until the door pin just penetrates the masking tape. Make sure the door pin contacts only the door latch spring.
- If door pin does not strike the center of the masking tape or spring hole in the U-channel, loosen the hinge-to-steamer bolts and align the door to the door pin. Tighten hinge-to-steamer mounting bolts.
- You should be able to pull a piece of paper smoothly between the gasket and steamer cavity with the door closed. To adjust the hinge side, loosen the door-to-hinge bolts and align the door gasket with the steamer cavity. Tighten the door-to-hinge mounting bolts. To adjust the bullet side, refer to Section 24.
- Operate steamer and check for leaks.

### 19. Door Switch (P/N 096857)

- From the right side of the steamer with panel removed, unplug the door switch from the electrical board.
- The switch (for normal door opening) is held in place with two small screws. With a slotted screwdriver, remove these screws and the switch may be removed.
- If the door has been reversed and the switch must be removed and replaced, refer to the top panel removal in Section 2 and then remove the switch as above.

### 20. Door Reversing Procedures (Refer to Sections 19 and 22 for additional instructions)

- Turn off steamer power and allow steamer to cool.
- To remove door, support door while removing hinge-to-steamer bolts.
- Place door with hinge on a flat, clean table (or similar support), with the gasket facing up. Be careful not to scratch door surface.
- Note and record distance between lock nut and end of door locking pin (bullet). This information will be needed during bullet installation in the sixth step.
- Loosen lock nut, then remove door bullet and lock nut.
- Coat bullet threads with a few drops of Loctite 222. Install bullet and lock nut directly across steamer cavity from old bullet location. Install these two items so that lock nut to end of bullet distance is approximately the same as measured in the fourth step.

# Service Procedures

## [FOR PROFESSIONAL TECHNICAL SERVICE PERSONNEL ONLY]

**WARNING**  
DISCONNECT THE POWER SUPPLY BEFORE  
BEGINNING ANY SERVICE PROCEDURE.



- Remove the two screws from above and below the old bullet location and install them above and below the new bullet location.
- Remove screws and U-channel from the door. Take magnet and block assembly from present location and place it at the opposite end of the door channel, with magnet facing outward from the door.
- Remove door handle screws and door handle from cam..
- Apply NEVER-SEEZ high temperature (1800 degrees F) anti-seize and lubricating compound to the cam and a few drops of Loctite 242 to door handle screw threads.
- Turn handle and cam 180-degrees from their original positions and install them on the door with screws. Be sure handle and cam move smoothly.
- Be sure door handle and door cam is in the DOWN position. Turn U-channel 180-degrees from its original position, hold door spring in U-channel open with a screwdriver or similar tool, and install U-channel.
- Check operation of the cam. Push up on the door handle and check if the spring opens. If the spring does not open, cam and spring are NOT correctly aligned and problem must be corrected.
- Apply a light amount of Loctite 242 to screws, then install screws.
- Apply Loctite 242 to the hinge-to-steamer bolts, then install door and hinge mounting bolts. Do NOT tighten mounting bolts at this time.
- Align door to steamer. Refer to Section 18.
- IMPORTANT. When the door is reversed, the alternate door switch (installed at time of manufacture) must be connected to the circuit.
- From the right side access to the upper portion of the steamer, disconnect the two leads of the door switch.
- The wires for the alternate door switch may be found under the cavity. Connect the two wires from the switch to the electrical board.
- Close steamer door and operate steamer. If fan does not operate, check location of door magnet and try operation again. If fan operation problem still exists, refer to Section 19.
- With the door closed and the steamer in the ON position, or with the timer running, the GREEN/READY light should come on.
- Allow steamer to operate for approximately five minutes, and then check for leaks. If there are no leaks, the steamer is ready for operation. If there are leaks around the door, recheck door alignment, and if necessary, door gasket installation.

### 21. Door Gasket (P/N 094147)

- To install, turn off steamer, and allow to cool.
- Remove the door using one of the following:
  - a. Support door weight and remove hinge pin, or
  - b. Support weight of the door and remove the two door-to-hinge bolts. Refer to Section 18 for more instructions.
- Position door on flat, clean workbench, smooth table or similar support so that the door front is lying flat, with its handle hanging over the edge of the bench. Be careful not to scratch the door.
- Remove inner door panel. Using a flat blade screwdriver, remove the four truss-head screws holding the panel in place.
- Remove and discard gasket.
- Clean back of the inner door panel. Be sure old sealant is completely removed.



# Service Procedures

## [FOR PROFESSIONAL TECHNICAL SERVICE PERSONNEL ONLY]

**WARNING**  
DISCONNECT THE POWER SUPPLY BEFORE  
BEGINNING ANY SERVICE PROCEDURE.



- Apply a high temperature silicone sealant, such as RTV 159 or equivalent, to the four door spacers
- Install new gasket around outer door panel on insulation board. Be sure the inner door panel flange is fully inserted into the gasket groove.
- Apply Locktite 242 to inner panel mounting screws and tighten.
- Align door with hinge and insert hinge pin OR apply Locktite 242 to the door-to-hinge bolts, then install door and mounting bolts. Do NOT tighten mounting bolts. Refer to Section 24 for more instructions.

### 22. Door Handle (P/N 070123) Magnet and Block Assembly (P/N 069762) Screws (P/N 005764)

**U-Channel Assembly (P/N 094144)**

**Door Cam (P/N 074252)**

**Outer Door Panel (P/N 094140)**

**Inner Door Panel (P/N 094141)**

**Door Insulation Board (P/N 094192)**

- Turn off steamer and allow it to cool.
- With flat blade screwdriver, remove the two 8-32 truss head screws on the U-channel. Remove U-channel from the door.
- Remove screws, door handle, and cam.
- Apply a high temperature (922 degrees C) anti-seize and lubricating compound to the door cam and Locktite 242 to the door handle screw threads.
- Assemble door cam to handle with screws and tighten.
- Be sure door handle is in the DOWN position. Hold U-channel door spring open with a screwdriver or similar tool, then install the U-channel. Do NOT install screws at this time.
- Check operation of the cam and door spring. Push up on the door handle and check if spring opens. If the spring does not open, the cam and spring are not correctly aligned and the problem must be corrected.
- Apply a light amount of Locktite 242 to screws, then install screws to U-Channel and tighten.

### 23. Door Spring (P/N 078911)

- Turn off steamer and allow it to cool.
- With flat blade screwdriver, remove two 8-32 truss head screws on U-channel. Remove U-channel from door.
- Carefully remove retaining ring from one end of spring support pin, then remove the pin by moving the pin left or right.
- With a 3/8 inch nutdriver, remove the 10-32 kep nut, lift square plate, then remove the spring.

# Service Procedures

## [FOR PROFESSIONAL TECHNICAL SERVICE PERSONNEL ONLY]

**WARNING**  
DISCONNECT THE POWER SUPPLY BEFORE  
BEGINNING ANY SERVICE PROCEDURE.



To Install:

- Apply a high temperature (922 degrees C) anti-seize, lubricating compound on the bottom of the U-Channel surface that contacts with the spring.
- Install spring onto brass roller, then place square plate over spring.
- Apply Locktite 242 to kep nut and install kep nut.
- Install spring support pin, then push the retaining ring onto the pin using a screwdriver.
- Hold door spring open with a screwdriver or similar tool, hold door handle in the DOWN position and install the U-channel, top end first - then lower channel into position. Check that spring opens when door handle is pushed up.
- Apply Locktite 242 to U-channel mounting screws, then install the screws.

### 24. Door Locking Pin (P/N 078914)

#### Pin Lock Nut (P/N 003823)

- Turn off steamer and allow it to cool.
- Note and record the distance between the lock nut and the end of the (bullet shaped) door locking pin. This information is important and will be needed for installation.
- Loosen lock nut and remove lock nut and door pin (bullet) from front panel.
- To install new door locking pin, coat locking pin threads with a few drops of Locktite 222.
- Install locking pin and lock nut. The lock nut to end-of-bullet distance should be approximately the same as measured above, in the second step.

### 25. Alternate Door Switch Location

The alternate door switch is located on the left side of the steamer as viewed from the front. In order to gain access to the switch for replacement purposes only, it is required to remove the right panel and top/left cover.

The leads for this alternate switch are provided adjacent to the wiring harness on the right side of the steamer. Refer to Section 2 and 19 for more instructions.

# Service Log

Model No:	Purchased From:
Serial No:	Location:
Date Purchased:	Date Installed:
Purchase Order No:	For Service Call:

Date	Maintenance Performed	Performed By



1055 Mendell Davis Drive • Jackson MS 39272  
888-994-7636 • 601-372-3903 • Fax 888-864-7636  
[unifiedbrands.net](http://unifiedbrands.net)