

IMPORTANT INFORMATION ☆ KEEP FOR OPERATOR ☆ IMPORTANT INFORMATION

OPERATOR MANUAL

Part Number 121002

OM-TDB/7

DOMESTIC

**MODEL: TDB/7
Steam Jacketed Kettle**

*Self-Contained
Electrically heated
Table top mounted
Tilting*



THIS MANUAL MUST BE RETAINED FOR FUTURE REFERENCE. READ, UNDERSTAND AND FOLLOW THE INSTRUCTIONS AND WARNINGS CONTAINED IN THIS MANUAL.

FOR YOUR SAFETY

DO NOT STORE OR USE GASOLINE OR OTHER FLAMMABLE VAPORS AND LIQUIDS IN THE VICINITY OF THIS OR ANY OTHER APPLIANCE.



Information contained in this document is known to be current and accurate at the time of printing/creation. Unified Brands recommends referencing our product line websites, unifiedbrands.net, for the most updated product information and specifications.



IMPORTANT — READ FIRST — IMPORTANT

- CAUTION:** BE SURE ALL OPERATORS READ, UNDERSTAND AND FOLLOW THE OPERATING INSTRUCTIONS, CAUTIONS, AND SAFETY INSTRUCTIONS CONTAINED IN THIS MANUAL.
- WARNING:** THIS UNIT IS INTENDED FOR USE IN THE COMMERCIAL HEATING, COOKING AND HOLDING OF WATER AND FOOD PRODUCTS, PER THE INSTRUCTIONS CONTAINED IN THIS MANUAL. ANY OTHER USE COULD RESULT IN SERIOUS PERSONAL INJURY OR DAMAGE TO THE EQUIPMENT AND WILL VOID WARRANTY.
- WARNING:** KETTLE MUST BE INSTALLED BY PERSONNEL QUALIFIED TO WORK WITH ELECTRICITY. IMPROPER INSTALLATION CAN RESULT IN INJURY TO PERSONNEL AND/OR DAMAGE TO EQUIPMENT.
- DANGER:** ELECTRICALLY GROUND THE UNIT AT THE TERMINAL PROVIDED. FAILURE TO GROUND UNIT COULD RESULT IN ELECTROCUTION AND DEATH.
- WARNING:** AVOID ALL DIRECT CONTACT WITH HOT EQUIPMENT SURFACES. DIRECT SKIN CONTACT COULD RESULT IN SEVERE BURNS.
- WARNING:** AVOID ALL DIRECT CONTACT WITH HOT FOOD OR WATER IN THE KETTLE. DIRECT CONTACT COULD RESULT IN SEVERE BURNS.
- CAUTION:** DO NOT OVER FILL THE KETTLE WHEN COOKING, HOLDING OR CLEANING. KEEP LIQUIDS A MINIMUM OF 2-3" (5-8 cm) BELOW THE KETTLE BODY RIM TO ALLOW CLEARANCE FOR STIRRING, BOILING AND SAFE PRODUCT TRANSFER.
- WARNING:** TAKE SPECIAL CARE TO AVOID CONTACT WITH HOT KETTLE BODY OR HOT PRODUCT WHEN ADDING INGREDIENTS, STIRRING OR TRANSFERRING PRODUCT TO ANOTHER CONTAINER.
- WARNING:** WHEN TILTING KETTLE FOR PRODUCT TRANSFER:
- 1) WEAR PROTECTIVE OVEN MITT AND PROTECTIVE APRON.
 - 2) USE CONTAINER DEEP ENOUGH TO CONTAIN AND MINIMIZE PRODUCT SPLASHING.
 - 3) PLACE CONTAINER ON STABLE, FLAT SURFACE, AS CLOSE TO KETTLE AS POSSIBLE.
 - 4) STAND TO LEFT OR RIGHT SIDE OF KETTLE (DEPENDING ON TILTING HANDLE PLACEMENT) WHILE POURING . DO NOT STAND DIRECTLY IN POUR PATH OF HOT CONTENTS.
 - 5) POUR SLOWLY, MAINTAIN CONTROL OF KETTLE BODY HANDLE AT ALL TIMES, AND RETURN KETTLE BODY TO UPRIGHT POSITION AFTER CONTAINER IS FILLED OR TRANSFER IS COMPLETE.
 - 6) DO NOT OVER FILL CONTAINER. AVOID DIRECT SKIN CONTACT WITH HOT CONTAINER AND ITS CONTENTS.
- CAUTION:** KEEP FLOORS IN FRONT OF KETTLE WORK AREA CLEAN AND DRY. IF SPILLS OCCUR, CLEAN IMMEDIATELY, TO AVOID SLIPS OR FALLS.
- WARNING:** FAILURE TO CHECK SAFETY VALVE OPERATION PERIODICALLY COULD RESULT IN PERSONAL INJURY AND/OR DAMAGE TO EQUIPMENT.
- WARNING:** WHEN TESTING, AVOID ANY EXPOSURE TO THE STEAM BLOWING OUT OF THE SAFETY VALVE. DIRECT CONTACT COULD RESULT IN SEVERE BURNS.
- WARNING:** TO AVOID INJURY, READ AND FOLLOW ALL PRECAUTIONS STATED ON THE LABEL OF THE WATER TREATMENT COMPOUND.
- WARNING:** BEFORE REPLACING ANY PARTS, DISCONNECT THE UNIT FROM THE ELECTRIC POWER SUPPLY.

IMPORTANT — READ FIRST — IMPORTANT

- WARNING:** KEEP WATER AND SOLUTIONS OUT OF CONTROLS AND ELECTRICAL EQUIPMENT. NEVER SPRAY OR HOSE THE SUPPORT HOUSING OR ELECTRICAL CONNECTIONS.
- CAUTION:** MOST CLEANERS ARE HARMFUL TO THE SKIN, EYES, MUCOUS MEMBRANES AND CLOTHING. PRECAUTIONS SHOULD BE TAKEN. WEAR RUBBER GLOVES, GOGGLES OR FACE SHIELD AND PROTECTIVE CLOTHING. CAREFULLY READ THE WARNINGS AND FOLLOW THE DIRECTIONS ON THE LABEL OF THE CLEANER TO BE USED.
- CAUTION:** USE OF ANY REPLACEMENT PARTS OTHER THAN THOSE SUPPLIED BY GROEN OR THEIR AUTHORIZED DISTRIBUTORS CAN CAUSE OPERATOR INJURY AND DAMAGE TO THE EQUIPMENT, AND WILL VOID ALL WARRANTIES.
- IMPORTANT:** SERVICE PERFORMED BY OTHER THAN FACTORY AUTHORIZED PERSONNEL WILL VOID WARRANTIES.

Table of Contents

IMPORTANT OPERATOR WARNINGS	2
EQUIPMENT DESCRIPTION	5
INSPECTION & UNPACKING	7
INSTALLATION	8
INITIAL START-UP	9
OPERATION	10
SEQUENCE OF OPERATION	12
MAINTENANCE	13
CLEANING	17
TROUBLESHOOTING	19
PARTS LISTS	
Units Manufactured Before Sept. 1, 1988	20
Units Manufactured Between Sept. 1, 1988 and July 1, 1992	22
Units Manufactured Between July 1, 1992 and Feb. 6, 1995	24
Units Manufactured After Feb. 6, 1995	26
DIAGRAMS & SCHEMATICS	
Units Manufactured Before Sept. 1, 1988	30
Units Manufactured After Sept. 1, 1988 and Before June 1, 1990	33
Units Manufactured After June 1, 1990 and Before July 1, 1992	36
Units Manufactured After June 1, 1990 and Before Feb. 6, 1995	37
Units Manufactured After July 1, 1992 and Before Feb. 6, 1995	38
Units Manufactured After Feb. 6, 1995	39
SERVICE LOG	42
REFERENCES	42
WARRANTY	43

Equipment Description

The Groen TDB/7 is a table top, tilting, steam jacketed kettle with a thermostatically controlled, self-contained, electrically-heated steam supply and appropriate controls, mounted on a sturdy base. The Model TDB/7 is available in 20 or 40 - quart capacity.

The body of the TDB/7 Kettle is constructed of stainless steel, welded into one solid piece. The kettle is furnished with a reinforced rim and a butterfly shaped pouring lip. It has a steam jacket rated for working pressures up to 50 PSI. Kettle finish is 180 emery grit on the inside and bright semi-deluxe on the outside. A tilt handle allows the operator to manually tilt the kettle body in a controlled manner. Pouring height accepts pans up to 4 inches high on a table top.

A built-in steam generator, sized for the kettle capacity and heated by electricity, delivers steam into the jacket. "Airless" operation of the steam jacket permits uniform, efficient heating at temperatures as low as 150°F and as high as 295°F. In addition to the adjustable thermostat for operating control, the unit has a tilt cut-off switch, low water cut-off, safety valve, and high-limit pressure switch as safety features. A heating indicator light, pressure gauge, and sight glass are provided for monitoring kettle operation.

A single electrical connection is required for installation. The unit may be ordered for use with 208/240 or 480 volt power. All kettles are wired for three-phase operation. For single-phase conversion, see the wiring diagrams in this manual.

KETTLE CHARACTERISTICS				
	TDB/7-20+		TDB/7-40	
Kettle Capacity	20 qts.	18.8 liters	40 qts.	37.6 liters
Jacket Capacity	4 qts.	3.7 liters	5 qts.	4.7 liters
Diameter	14"	36 cm	16-1/2"	42 cm
Depth	11"	28 cm	14-1/4"	36 cm
K.W. at 208 V	6.3		10.8	
K.W. at 240 V	8.4		14.4	
K.W. at 480 V	6.3		12.0	
Base Width	24"	60 cm	24"	60 cm
Base Depth	16"	41 cm	16"	41 cm

New/Current Models



Pre- Feb. 1995 Models



Optional equipment available with any model:

1. Stand that supports the unit and holds a pan in position for filling
2. Lift-off cover
3. Basket insert
4. Fill faucet
5. Manual stirrers
6. Motor driven agitator

Inspection & Unpacking

The unit will arrive in a heavy shipping carton and will be attached to a skid. Immediately upon receipt, inspect the carton carefully for exterior damage.

CAUTION
SHIPPING STRAPS ARE UNDER TENSION AND CAN SNAP BACK WHEN CUT. TAKE CARE TO AVOID PERSONAL INJURY OR DAMAGE TO THE UNIT BY STAPLES LEFT IN THE WALLS OF THE CARTON.

Carefully cut the polyester straps around the carton and detach the sides of the box from the skid. Pull the carton up off the unit.

Thoroughly inspect the unit for concealed damage. Report any shipping damage or incorrect shipments to the delivery agent.

Write down the model number, serial number, and installation date, and retain this information for future reference. Space for these entries is provided at the top of the Service Log at the back of this manual. Keep this manual on file and available for operators to use.

CAUTION
THIS UNIT WEIGHS 140 TO 163 LB. (64 TO 74 KG). INSTALLER SHOULD OBTAIN HELP AS NEEDED TO LIFT THIS WEIGHT SAFELY.

When installation is to begin, carefully cut the straps which hold the unit on the skid. Lift the unit straight up off the skid. Examine packing materials to be sure loose parts are not discarded with the materials.

Attach the tilt handle (normally shipped inside the kettle) by carefully threading it into the socket on the trunnion support. Be careful to avoid cross-threading fine socket threads.

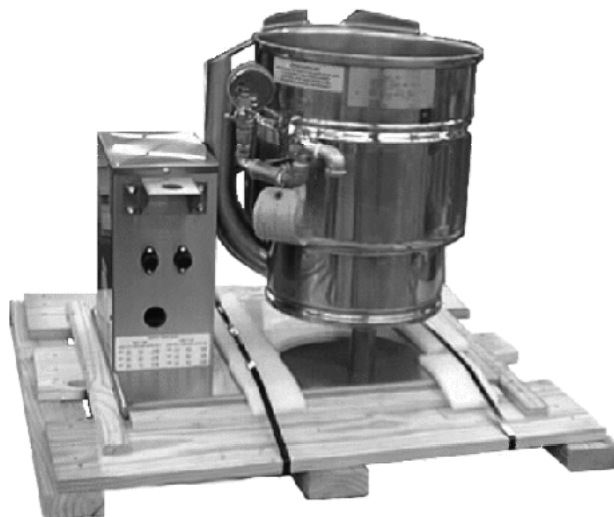

The TDB/7 is shipped from the factory strapped on a pallet. The tilt handle is inside the kettle.

Installation

The Groen Kettle is provided with complete internal wiring. It is ready for immediate connection. A wiring diagram is provided in this manual and on the inside of the control housing service panel. Any mechanical or electrical changes must be approved in by Groen's Food Service Engineering Department.



- The equipment is shipped ready for three phase operation. Refer to the wiring diagram for single phase operation.
- Bringing the electrical service through the entrance at the rear of the support housing, making a watertight connection with the incoming lines. (A BX connection is **not** recommended.)

WARNING

INSTALLATION OF THE KETTLE MUST BE DONE BY PERSONNEL QUALIFIED TO WORK WITH ELECTRICITY. IMPROPER INSTALLATION CAN RESULT IN INJURY TO PERSONNEL AND/OR DAMAGE TO EQUIPMENT.

DANGER

ELECTRICALLY GROUND THE UNIT AT THE TERMINAL PROVIDED. FAILURE TO GROUND UNIT COULD RESULT IN ELECTROCUTION AND DEATH.

The completed unit has been operated at the factory to test all controls and heater elements.

- Set the kettle in place and level it. The base should be securely fastened to a table or work surface. Four 3/8"-16 N.C. threaded couplings are provided in the base of unit. Installation under a ventilation hood is recommended.
- Provide electrical power as specified on the electrical information plate attached to the equipment. Observe local codes and/or The National Electrical Code in accordance with ANSI/NFPA 70 - (current edition).

- Confirm that the jacket water level is above mid point of sight glass (new models) or between the marks on the gauge glass (old models). If the level is low, follow the instructions under "Jacket Filling and Water Treatment" in the "Maintenance" section of the manual.
- The open end of the elbow on the outlet of the safety valve must be directed downward on old models. If it is not, turn the elbow to the correct position. On new models the safety valve points down.
- Any mechanical or electrical change must be approved by the Groen Food Service Engineering Department.

TDB/7 ELECTRICAL SPECIFICATIONS

VOLTAGE	PHASE	20 QUARTS		40 QUARTS	
		KW	AMPS	KW	AMPS
208	1	6.3	31	10.8	52
208	3	6.3	18	10.8	30
240	1	8.4	35	14.4	60
240	3	8.4	20	14.4	35
480	1	6.3	13	12.0	25
480	3	6.3	8	12.0	15
400	3	7.8	11.2	13.2	19

TDB/7 SUPPLY WIRE REQUIREMENTS

Copper only, THHN (90°C)

VOLTAGE	PHASE	20 QUARTS		40 QUARTS	
		AWG	mm	AWG	mm
208	1	8	—	6	—
	3	12	—	8	—
240	1	8	3.0	4	3.5
	3	10	—	8	—
480	1	14	—	10	—
	3	14	—	12	—
400	3	—	1.8	—	2.5

Initial Start-Up

IMPORTANT:

BE SURE ALL OPERATORS READ, UNDERSTAND AND FOLLOW THE OPERATING INSTRUCTIONS, CAUTIONS, AND SAFETY INSTRUCTIONS CONTAINED IN THIS MANUAL.

Now that the kettle has been installed, you should test it to ensure that the unit is operating correctly.

1. Remove all literature and packing materials from inside and outside of the unit.
2. Turn on the electrical service to the unit.
3. Pour 1-2 quarts of water into the kettle.
4. Following "To Start Kettle" instructions in the "Operation" section of this manual, begin heating the water at the highest thermostat setting. The heating indicator light should come on immediately, and heating should continue until the water boils.
5. To shut down the unit, turn the thermostat dial to "OFF".



WARNING

AVOID ALL DIRECT CONTACT WITH HOT SURFACES. DIRECT SKIN CONTACT COULD RESULT IN SEVERE BURNS.

AVOID ALL DIRECT CONTACT WITH HOT FOOD OR WATER IN THE KETTLE. DIRECT CONTACT COULD RESULT IN SEVERE BURNS.

If the unit functions as described above, it is ready for use. If the unit does not function as intended, contact your local Groen Certified Service Agency.



A simple turn of the thermostat controls the Groen TBD/7 Kettle

Operation

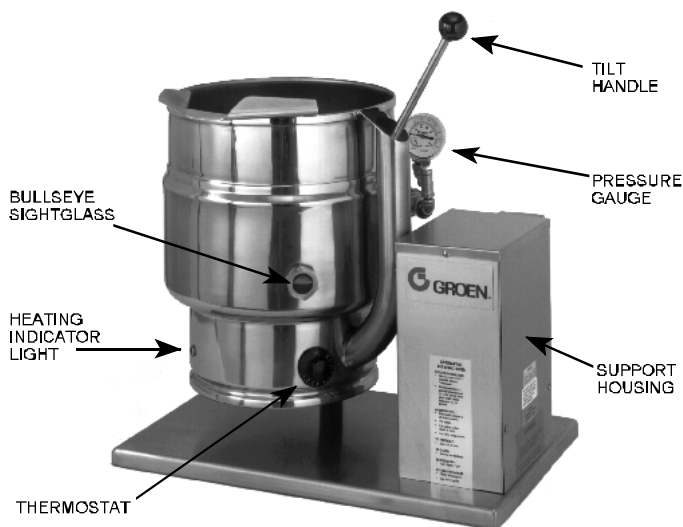

The operator controls kettle heating with the thermostat dial. The dial turns heating element electric power on or off and sets the operating temperature of the kettle.

A. To Start Kettle

1. EVERY DAY make sure that the jacket water level is above the mid-point of the round sight glass (new models) or between the marks on the gauge glass

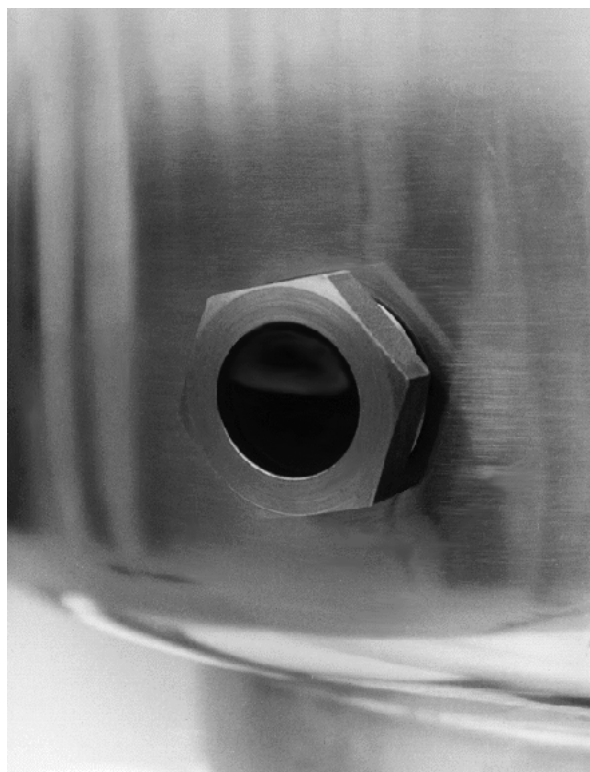

On most TDB/7 units the jacket water level is shown in a sight glass, right on the kettle.

- (old models). If the level is too low, see "Jacket Filling and Water Treatment" on page 10 of this manual.
2. Check the pressure gauge. If the gauge does not show 20 to 30 inches of vacuum (that is, a reading of 20 to 30 below 0), see "Jacket Vacuum" on page 10 of this manual.
3. Turn on the electrical power to the unit.
4. Turn the thermostat dial to the desired setting. The heating indicator light indicates that the kettle is heating, and cycling of the light on and off indicates that the kettle is being held at the set temperature. Once in each cycle the contactors in the support housing will make a clicking sound. This is normal.

B. To Transfer Product or Empty Kettle:

The kettle is designed and manufactured to be tilted in a controlled manner. Grasp the insulated plastic ball firmly. Maintain a firm grip on handle when tilting, while keeping kettle body in a tilted position and when SLOWLY returning the kettle body to an upright position.



WARNING
 AVOID ALL DIRECT CONTACT WITH HOT SURFACES. DIRECT SKIN CONTACT COULD RESULT IN SEVERE BURNS.

AVOID ALL DIRECT CONTACT WITH HOT FOOD OR WATER IN THE KETTLE. DIRECT CONTACT COULD RESULT IN SEVERE BURNS.

TAKE SPECIAL CARE TO AVOID CONTACT WITH HOT KETTLE BODY OR HOT PRODUCT, WHEN ADDING INGREDIENTS, STIRRING OR TRANSFERRING PRODUCT TO ANOTHER CONTAINER.

CAUTION
 DO NOT OVERFILL THE KETTLE WHEN COOKING, HOLDING OR CLEANING. KEEP LIQUIDS AT LEAST 2-3" (5-8 cm) BELOW THE KETTLE BODY RIM TO ALLOW CLEARANCE FOR STIRRING, BOILING PRODUCT AND SAFE TRANSFER.

WARNING

WHEN TILTING KETTLE FOR PRODUCT TRANSFER:

- 1) WEAR PROTECTIVE OVEN MITT AND PROTECTIVE APRON.
- 2) USE DEEP CONTAINER TO CONTAIN AND MINIMIZE PRODUCT SPLASHING.
- 3) PLACE CONTAINER ON STABLE, FLAT SURFACE, AS CLOSE TO KETTLE AS POSSIBLE.
- 4) STAND TO LEFT OR RIGHT OF KETTLE (DEPENDING ON HANDLE PLACEMENT) WHILE POURING — NOT DIRECTLY IN POUR PATH OF HOT CONTENTS.
- 5) POUR SLOWLY, MAINTAIN CONTROL OF KETTLE BODY HANDLE AT ALL TIMES, AND RETURN KETTLE BODY TO UPRIGHT POSITION AFTER CONTAINER IS FILLED OR TRANSFER IS COMPLETE.
- 6) DO NOT OVERFILL CONTAINER. AVOID DIRECT SKIN CONTACT WITH HOT CONTAINER AND ITS CONTENTS.

**CAUTION**

KEEP FLOORS IN FRONT OF THE KETTLE WORK AREA CLEAN AND DRY. IF SPILLS OCCUR, CLEAN AT ONCE TO AVOID SLIPS OR FALLS.

Common Accessories

1. Lift Off Cover

As with stock pot cooking, an optional lift off cover can speed up the heating of water and food products. A cover helps retain heat in the cooking vessel and reduces the amount of heat and humidity released into the kitchen. Use of a cover can reduce some product cook times and help maintain the temperature, color and texture of products being held or simmered for extended periods.

Make sure the plastic ball handle is secure on the lift off cover before using. ALWAYS use the plastic handle to place or remove cover from the kettle. Wear protective oven mitts and a protective apron.

When putting the cover on the kettle, position it on top of kettle rim, with its flat edge facing the pouring lip.

**WARNING**

AVOID ALL DIRECT CONTACT WITH HOT SURFACES. DIRECT SKIN CONTACT COULD RESULT IN SEVERE BURNS.

AVOID ALL DIRECT CONTACT WITH HOT FOOD OR WATER IN THE KETTLE. DIRECT CONTACT COULD RESULT IN SEVERE BURNS.

When removing cover:

- a) Firmly grasp plastic handle
- b) Lift rear edge (farthest from operator) 1-2" (3-5 cm) to allow any steam and water vapor to escape the cooking vessel. Wait 2-3 seconds.
- c) Tilt cover to 45-60° angle and allow any hot



Lift the rear edge of the cover first.

condensate or product to roll off cover back into kettle.

- d) Remove cover, ensuring that any remaining hot condensate or product does not drip on operator, floor or work surfaces.
- e) Place cover on safe, flat, sanitary, out-of-the-way surface, or return to kettle rim.

CAUTION

DO NOT TILT KETTLE BODY WITH COVER IN PLACE. COVER MAY SLIDE OFF, CAUSING INJURY TO OPERATOR.

OM-TDB/7

2. Basket Insert

An optional kettle basket insert can assist in cooking water-boiled products including eggs, potatoes, vegetables, shell fish, pasta and rice. The nylon mesh liner must be used when cooking product smaller than the mesh size of the basket, which is approximately 1/4" (6 mm). This includes rice and small pasta shapes.

Tips For Use.

- a) Allow for the water displacement of the basket and product to be cooked. This may mean only filling the kettle half full of water. Test the basket and product displacement with the kettle OFF, and with cold water in the kettle.

CAUTION
DO NOT OVERFILL THE KETTLE WHEN COOKING, HOLDING OR CLEANING. KEEP LIQUIDS A MINIMUM OF 2-3" (5-8 cm) BELOW THE KETTLE BODY RIM TO ALLOW CLEARANCE FOR STIRRING, BOILING AND SAFE PRODUCT TRANSFER.



WARNING
AVOID ALL DIRECT CONTACT WITH HOT SURFACES. DIRECT SKIN CONTACT COULD RESULT IN SEVERE BURNS.

AVOID ALL DIRECT CONTACT WITH HOT FOOD OR WATER IN THE KETTLE. DIRECT CONTACT COULD RESULT IN SEVERE BURNS.

- b) Load basket on a level, stable work surface.
- c) Lift the loaded basket with both hands. Get help from another person if the basket is too heavy for safe handling.
- d) Slowly lower product into kettle.
- e) When removing basket with cooked product, lift basket straight up, ensuring bottom of basket clears the rim and pouring lip of the kettle. Wear protective oven mitts and protective apron.
- d) Allow hot water to fully drain from product, before moving basket away from the kettle. Do not rest kettle basket on kettle rim or pouring lip. If basket is too heavy for individual to lift and safely move, get help from another person. Remove product immediately from basket into another container, being sure to avoid contact with hot product and hot basket **or** . . .
- e) Place basket with food on stable, flat surface, setting it inside a solid steamer or bake pan, to catch any remaining hot water draining from product.

Sequence of Operation

The following "action-reaction" outline is provided to help the user understand how the equipment works.

When the operator starts up the kettle by turning the operating thermostat dial from "OFF" to a desired setting, the thermostat switch closes. This lights up the heating indicator light and causes the contactors to close, allowing power to flow to heating elements. When the temperature of the steam jacket reaches the value corresponding to the dial setting, the thermostat switch opens. This turns off the heating indicator light and causes the contactors to open, stopping the power to the heaters. As soon as the thermostat senses that the kettle is cooling below the set point, the thermostat switch closes, the heating indicator light comes on, the contactors close, and the heaters come

on again. On-off cycling continues, keeping the kettle at the set temperature. This is why the heating indicator light cycles on and off during normal operation. Every time the kettle is tilted, the tilt cut-off switch interrupts the power supply to the heaters, so that the heating elements will not operate while not submerged in the jacket water.

If steam pressure greater than 50 PSI is generated in the jacket, the safety valve will open and relieve the excess pressure.

In the event that the jacket water level gets too low and the heating elements overheat, the high-limit control will open and shut off power to the elements until the kettle cools. Setting the operating thermostat dial to "OFF" shuts down all control and heating circuits.

Maintenance

NOTICE: Contact Groen or an authorized Groen representative when repairs are required.

1. Periodic Maintenance

A Maintenance & Service Log is provided at the back of this manual with the warranty information. Each time maintenance is performed on your Groen kettle, enter the date on which the work was done, what was done, and who did it. Keep this manual on file and available for operators to use.

Periodic inspection will minimize equipment down time and increase the efficiency of operation. The following points should be checked:

[BY OPERATOR]

- a. Check the pressure/vacuum gauge every day. The gauge should show a vacuum of 20 to 30 inches, when the kettle is cold. If it does not, see "Jacket Vacuum" on page 10.



The pressure gauge should show a vacuum of 20 to 30 inches when the kettle is cold.

- b. Also check the jacket water level on a daily basis. It should be above mid point of round sight glass (new models) or between the marks on the gauge glass (old models). If the level is low, see "Jacket Filling and Water Treatment" on page 14.

[BY SERVICE TECHNICIAN]

- c. Electrical wiring should be kept securely connected and in good condition.
- d. The inside of the support housing should be kept clean.

Test the safety valve at least twice each

month. Test the valve with the kettle operating at 15 psi (105 kPa), by holding the test lever for at least 5 seconds. Then release the lever and let the valve snap shut. If the lever does not activate, or there is no evidence of discharge, or the valve leaks, immediately discontinue use of the kettle and contact a qualified Groen service representative.



WARNING
WHEN TESTING, AVOID ANY EXPOSURE TO THE STEAM BLOWING OUT OF THE SAFETY VALVE. DIRECT CONTACT COULD RESULT IN SEVERE BURNS. DISCONNECT ELECTRICAL POWER FROM THE KETTLE BEFORE ATTEMPTING TO GREASE THE TRUNNION BEARINGS.

At least twice a year, grease the two trunnion bearings. The bearings are located within the kettle support housing. Remove the access panels from the support housing with a screwdriver to gain access to the grease fittings. Use a lithium-based, multi-purpose grease. When the access panels are removed, the mounting bolts for the trunnion bearings and tilt switch can also be checked for tightness. When finished, reassemble access panels to support housing.

2. Jacket Vacuum

When the kettle is cold, a positive pressure reading or a reading around zero on the pressure/vacuum gauge indicates the presence of air in the jacket. Air in the jacket slows down the heating of the kettle.

To remove air:

- a. Start the unit. (See the "Operation" section of this manual.) (Be sure there is water or product in the kettle when heating).
- b. When the pressure/vacuum gauge reaches a positive pressure reading of 5 PSI, release the trapped air and steam by pulling up or out on the safety valve

OM-TDB/7

lever or ring for about 1 second. Repeat this step, then let the pull ring or valve lever snap back into the closed position.

3A. Jacket Filling and Water Treatment (For units manufactured before July 1, 1992) *

The jacket was charged at the factory with the proper amount of treated water. You may need to restore the water to its proper level, either because water was lost as steam during venting or because treated water was lost by draining.

- If you are replacing water lost as steam, use distilled water. If you are replacing treated water that ran out of the jacket, prepare more treated water as directed in step 4, "Water Treatment Procedure."
- Allow the kettle to cool. Turn the elbow on the safety valve counterclockwise (to avoid thread damage) until the opening of the elbow faces upward.
- Open the safety valve and pour the water or treated water in at the elbow until the water level rises to a point between the marks on the gauge glass.

CAUTION
BEFORE YOU HEAT THE KETTLE FOR ANY PURPOSE, TURN THE ELBOW CLOCKWISE UNTIL THE OPENING AGAIN FACES DOWNWARD.

- Air introduced to the jacket during the filling operation must be removed to obtain efficient heating. See "Jacket Vacuum" above.

** Date of manufacture stamped on National Board data plate.*

3B Jacket Filling and Water Treatment (For units manufactured July 1, 1992 to Feb. 6, 1995) *

The jacket was charged at the factory with the proper amount of treated water. You may need to restore the water to its proper level, either because water was lost as steam during venting or because treated water was lost by draining.

IMPORTANT: The pressure gauge must read 0 PSI or less before you fill jacket with water.

To fill jacket with water:

- If you are replacing water lost as steam, use distilled water. If you are replacing treated water that ran out of the jacket, prepare more treated water as directed in step 4, "Water Treatment Procedure."

- Tilt kettle 90° to a full pour position.
- Remove fill plug with open-end wrench or crescent wrench.
- Open shutoff valve (turn handle 90° on ball valve).
- Use a funnel and add water to jacket.
- Check water level in jacket by tilting kettle to operating position and viewing water gauge glass.
- Repeat steps e and f until water level is between the maximum and minimum indication marks on the water gauge glass.
- Close shutoff valve, install fill plug, and return kettle to operating position.

Follow procedure under "Jacket Vacuum" to remove air from kettle jacket.

** Date of manufacture stamped on National Board data plate.*

C Jacket Filling and Water Treatment (For units manufactured after Feb. 6 1995) *

The jacket was charged at the factory with the proper amount of treated water. You may need to restore the water to its proper level, either because water was lost as steam during venting or because treated water was lost by draining.

IMPORTANT
Pressure gauge must read 0 PSI or less before you fill jacket with water.

To fill jacket with water:

- If you are replacing water lost as steam, use distilled water. If you are replacing treated water that ran out of the jacket, prepare more treated water as directed in step 4, "Water Treatment Procedure".
- Remove fill plug with open-end wrench or crescent wrench.
- Open shutoff valve (turn handle 90° on ball valve).
- Use a funnel and add water to jacket.
- Check water level in jacket, by viewing water level indicator glass.
- Continue to add water until the water level indicator glass is 3/4 full.
- Close shutoff valve, and install fill plug.

Follow procedure in "Jacket Vacuum" to remove air from kettle jacket.

** Date of manufacture stamped on National Board data plate.*

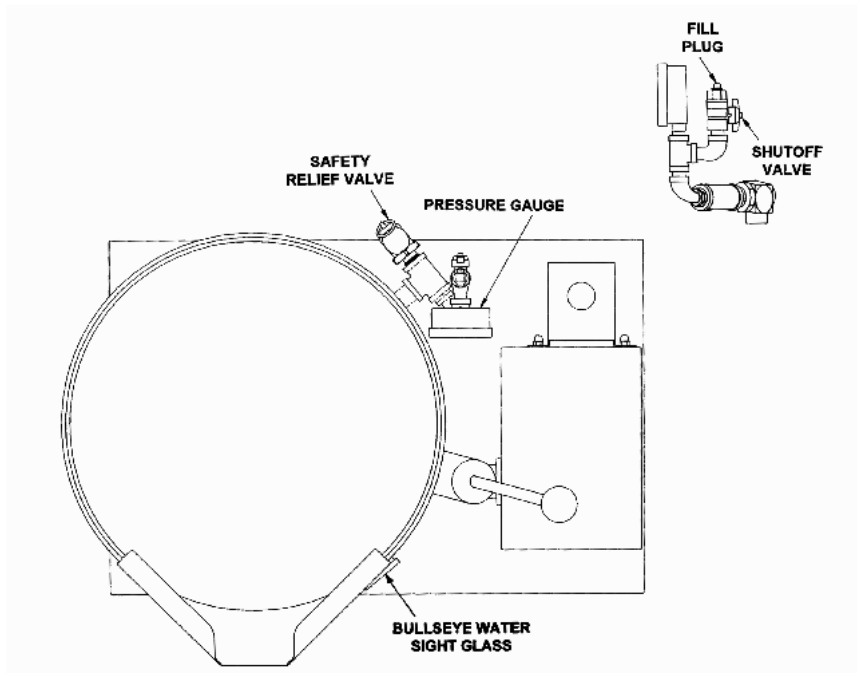
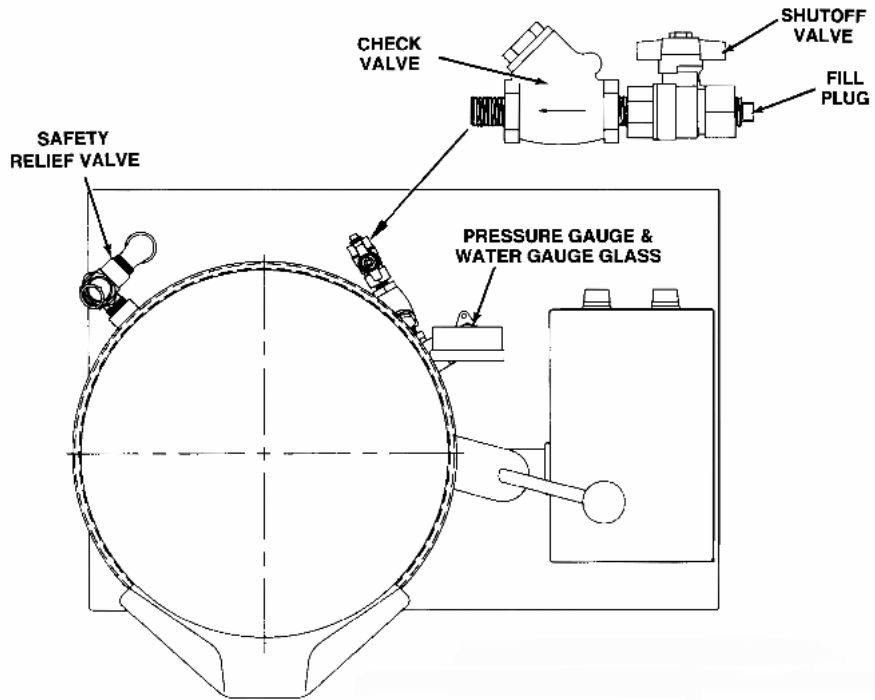

OM-TDB/7

4. Water Treatment Procedure

WARNING
TO AVOID INJURY, READ AND FOLLOW ALL PRECAUTIONS STATED ON THE LABEL OF THE WATER TREATMENT COMPOUND.

- (1) Fill the mixing container with the measured amount of water required. (See the table at right). Distilled water is recommended.
- (2) Hang a strip of pH test paper on the rim of the container, with about 1 inch of the strip below the surface of the water.
- (3) Measure the water treatment compound you will be using. (One way to do this is to add the compound from a measuring cup.)
- (4) Stir the water continuously, while you slowly add water treatment compound, until the water reaches a pH between 10.5 and 11.5. Judge the pH by frequently comparing the color of the test strip with the color chart provided in the pH test kit. Color blind people mixing the treated water solution must use an electroanalytical instrument to measure the pH level or have a person that is not color blind read the test strip color level.
- (5) Record the exact amounts of water and treatment compound used. These amounts may be used again, if the same sources of water and compound are employed to refill the jacket in the future. However, it is advisable to check the pH every time treated water is prepared.

Model	Kettle Capacity	Jacket Capacity
TDB/7-20	20 quarts	4 quarts
TDB/7-40	40 quarts	5 quarts

5. Component Replacement



WARNING
BEFORE REPLACING ANY PARTS, DISCONNECT THE UNIT FROM THE ELECTRIC POWER SUPPLY.

All internal wiring is marked as shown on the circuit schematic drawings. Be sure that new components are wired in the same manner as the old components.

Cleaning

1. Suggested Tools:

- Cleaner, such as Klenzade HC-10 or HC-32 from ECOLAB, Inc.
- Kettle brushes in good condition.
- Sanitizer such as Klenzade XY-12.
- Film remover such as Klenzade LC-30.

2. Precautions

Before cleaning, shut off the kettle by turning the thermostat dial to "OFF," and shut off all electric power to the unit at a remote switch, such as the circuit breaker.

- Prepare a hot solution of the detergent/cleaning compound as instructed by the supplier. Clean the unit thoroughly. A cloth moistened with cleaning solution can be used to clean controls, housings, and electrical conduits.
- Rinse the kettle thoroughly with hot water, then drain completely.
- As part of the daily cleaning program, clean soiled external and internal surfaces. Remember to check the sides of the unit and control housing.
- To remove stuck materials, use a brush, sponge, cloth, plastic or rubber scraper, or plastic wool with the cleaning solution. To reduce effort required in washing, let the detergent solution sit in the kettle and soak into the residue. Do NOT use abrasive materials or metal tools that might scratch the surface. Scratches

WARNING
KEEP WATER AND SOLUTIONS AWAY FROM CONTROLS AND ELECTRICAL EQUIPMENT. NEVER SPRAY THE SUPPORT HOUSING OR ELECTRICAL CONNECTIONS.



CAUTION
MOST CLEANERS ARE HARMFUL TO THE SKIN, EYES, MUCOUS MEMBRANES, AND CLOTHING. PRECAUTIONS SHOULD BE TAKEN. WEAR RUBBER GLOVES, GOGGLES OR FACE SHIELD, AND PROTECTIVE CLOTHING. READ THE WARNINGS AND FOLLOW THE DIRECTIONS ON THE LABEL OF THE CLEANER CAREFULLY

3. Procedure

- Clean food-contact surfaces as soon as possible after use. If the unit is in continuous use, thoroughly clean and sanitize the interior and exterior at least once every 12 hours.

WARNING
AVOID ANY DIRECT CONTACT WITH HOT SURFACES. DIRECT SKIN CONTACT COULD RESULT IN SEVERE BURNS.

- Scrape and flush out food residues. Be careful not to scratch the kettle with metal implements.



Use only a sponge, cloth or plastic brush to clean the kettle.



Scrapers or steel wool can harm the kettle surface.

OM-TDB/7

make the surface harder to clean and provide places for bacteria to grow.

Do NOT use steel wool, which may leave particles in the surface and cause eventual corrosion and pitting.

- g. The outside of the unit may be polished with a stainless steel cleaner such as "Zepper" from Zep Manufacturing Co.
- h. When equipment needs to be sanitized, use a solution equivalent to one that supplies 200 parts per million available chlorine. Obtain advice on sanitizing agents from your supplier of sanitizing products. Following the supplier's instructions, apply the agent after the unit has been cleaned and drained. Rinse off the sanitizer thoroughly.

- i. It is recommended that each piece of equipment be sanitized just before use.
- j. If there is difficulty removing mineral deposits or a film left by hard water or food residues, clean the kettle thoroughly and then use a deliming agent, like Groen Delimer/Descaler (Part Number 114800) or Lime-Away from Ecolab, in accordance with the manufacturer's directions. Rinse and drain the unit before further use.
- k. If cleaning problems persist, contact your cleaning product representative for assistance. The supplier has a trained technical staff with laboratory facilities to serve you.

NOTICE

NEVER LEAVE A CHLORINE SANITIZER IN CONTACT WITH STAINLESS STEEL SURFACES LONGER THAN 30 MINUTES. LONGER CONTACT CAN CAUSE STAINING AND CORROSION.

Troubleshooting

Your Groen kettle is designed to operate smoothly and efficiently if properly maintained. However, the following is a list of checks to make in the event of a problem. Wiring diagrams are furnished inside the service panel. **If an item on the list is followed by X, the work should be done by a qualified service representative.**

USE OF ANY REPLACEMENT PARTS OTHER THAN THOSE SUPPLIED BY GROEN OR THEIR AUTHORIZED DISTRIBUTORS CAN CAUSE INJURY TO THE OPERATOR AND DAMAGE TO THE EQUIPMENT AND WILL VOID ALL WARRANTIES.

SYMPTOM	WHO	WHAT TO CHECK <small>X indicates items which must be performed by an authorized technician.</small>
Kettle will not heat, and heating indicator will not come on.	User	a. Electric power supply to the unit. b. Water level in jacket.
	Auth Service Rep Only	c. Control circuit fuses. Replace a blown fuse only with a fuse of the same AMP rating. X d. For loose or broken wires. X e. Tilt cut-off switch. X f. That pressure switch is open. X g. Operation of variable thermostat. X h. Low water cutoff. X
Kettle will not heat, but heating indicator comes on.	Auth Service Rep Only	a. Contactor. X b. Heater elements with ohmmeter for ground short or open element. If element is defective, call Groen. X
Kettle continues heating after it reaches the desired temperature	User	a. Thermostat dial setting.
	Auth Service Rep Only	b. Thermostat circuit for short. X c. Thermostat operation. The thermostat should click when the dial is rotated above and below the setting for the temperature of the kettle. X d. Contactor, to determine whether it is energized or stuck. X
Kettle stops heating before it reaches the desired temperature.	User	a. Thermostat dial setting.
	Auth Service Rep Only	b. Thermostat calibration. X c. Thermostat operation. The thermostat should click when the dial is rotated above and below the setting for the temperature of the kettle. X
Kettle heats slowly	User	a. For air in the jacket. See "Jacket Vacuum" in the "Maintenance" section of this manual.
	Auth Service Rep Only	b. Heater elements with ohmmeter for ground short or open element. If an element is defective, call Groen. X c. Voltage of main power source. X
Safety valve pops.	User	a. For air in the jacket. See "Jacket Vacuum" in the "Maintenance" section of this manual.
	Auth Service Rep Only	b. Pressure switch setting. X c. Thermostat operation. Thermostat should click when the dial is rotated above and below the setting for the temperature of the kettle. X d. Safety valve. If the valve pops at pressures below 49 PSI, replace it. X e. Contactor, to determine whether it is de-energized. X

OM-TDB/7

I. Parts List (For units manufactured *before* September 1, 1988) *

To order parts, contact your Groen Certified Service Agency. Supply the model designation, part description, part number, quantity, and, where applicable, voltage and phase.

Key	Description	Part No.	Key	Description	Part No.
1	Kettle Assembly TDB/7-20	003144	24	Street EL 1/4" IPS X 90"	010668
	Kettle Assembly TDB/7-40	003145	25	Block, Pillow, 1-1/2"	002989
2	Base Assembly	054174	26	Collar, Set	003118
3	Bottom Cover	003141	27	Set Screw 3/8" - 16NC x 1/2"	003117
4	Gasket, U-channel	007937	28	Micro Switch	002982
5	Pedestal Weldment	002990	29	Bracket, Micro Switch	002988
6	Pedestal Cladding, 480V Only	003148	30	Contactor	(See table)
	Pedestal Cladding, 208-240V	003147	31	Transformer	012827
7	Screw #8 X 1/2"	005002	32	Fuse, 3 AMP, 480V Only	002651
8	Cap, Pedestal	003137	33	Terminal Block, 208-240V	002864
9	Cover, TDB/7-40	003136		Terminal Block, 480V	003119
	Cover, TDB/7-20	003139	34	Fuse Holder	002944
10	Screw, RHMS #8-32 X 3/8"	005724	35	Fuse	(See table)
11	Nut, KEPS 1/4" X 20 NC	012940	36	Screw, RHMS #8-32 X 3/4"	012656
12	Handle Assembly	012695	37	Spacer	003146
	Ring, Tolerance	012692	38	Screw Hex Head 1/2"-13 NCx3 1/2"	003285
13	Bumper, TDB/7-40	003248	39	Nut, Hex 1/2" - 13 NC	005705
	Bumper, TDB/7-20	003241	40	Lock Washer 1/2"	005735
14	Washer (As Required)	003242	41	Pressure Gauge	001594
	Washer (As Required)	003243	42	Fittings, Gauge Glass	002845
15	Screw, Hex Head 1/2" - 13 NC X 1"	005622	43	Rubber Gauge Glass Gasket	008917
16	Thermostat	012313	44	Washer (With Item 42)	—
17	Screw, RHMS #6-32 NC X 1/2"	012603	45	Hex Nut (With Item 42)	—
18	Knob, Thermostat	002868	46	Glass, Gauge	002987
19	Pilot Light, 208-240V	016028	47	Rod, Gauge Glass Guard	003127
	Pilot Light, 480V	002986	48	Nut, Dome #10 - 24 NC	005470
20	Basket for TDB/7-20	001607	49	Thermostat, High Limit	004588
	Basket for TDB/7-40	001121		Bracket, Bottom	002916
21	Cover, One Piece Lift-off, TDB/7-40	013496		Grommet, Thermostat	001518
	Cover, One Piece Lift-off, TDB/7-20	001566		Grommet, Trunion	003492
22	Knob, Maroon Ball	012691		Grommet	007400
23	Valve, Safety	005587		Elbow	004185

ELECTRICAL PARTS TABLE

Model	KW	AMP	Contactor	Pilot Light	Transformer	Wire Harness	Fuse
TDB/7-20							
208V/1 Ph	6.3	31	009173	016028	None	003175	002945
240V/1 Ph	6.3	27	009178	016028	None	003175	002945
480V/1 Ph	6.3	14	009576	002986	012827	003172	002651
208V/3 Ph	6.3	18	009210	016028	None	003174	002945
240V/3 Ph	6.3	16	009210	016028	None	003174	002945
480V/3 Ph	6.3	8	009574	002986	012827	003170	002651
TDB/7-40							
208V/1 Ph	10.8	52	013368	016028	None	003168	002945
240V/1 Ph	12	50	013368	016028	None	003168	002945
480V/1 Ph	12	25	009576	002986	012827	003166	002651
208V/3 Ph	10.8	30	009210	016028	None	003167	002945
240V/3 Ph	12	30	009210	016028	None	003167	002945
480V/3 Ph	12	15	009574	002986	012827	003165	002651

* Date of manufacture is stamped on National Board data plate.

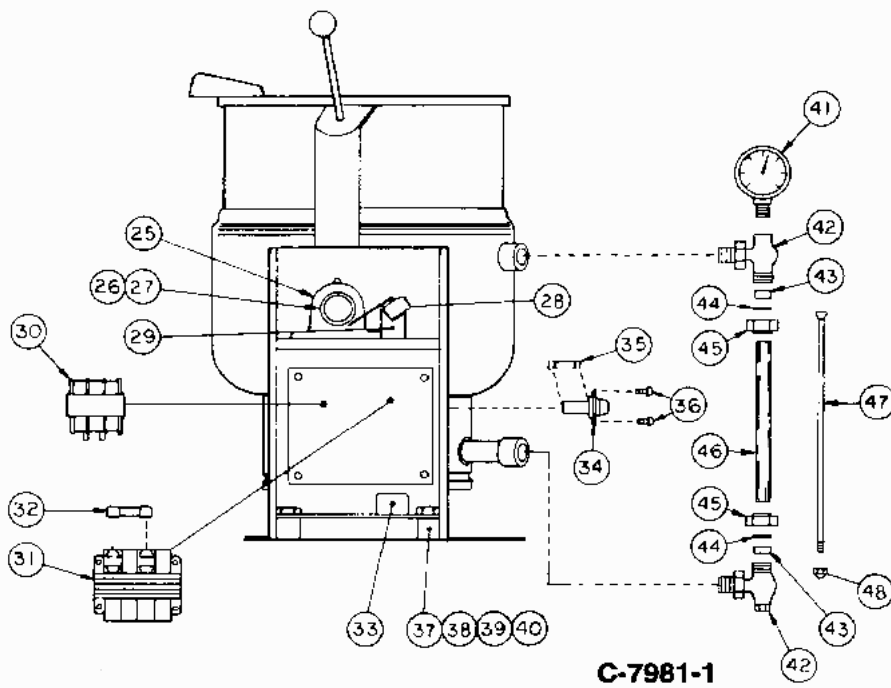
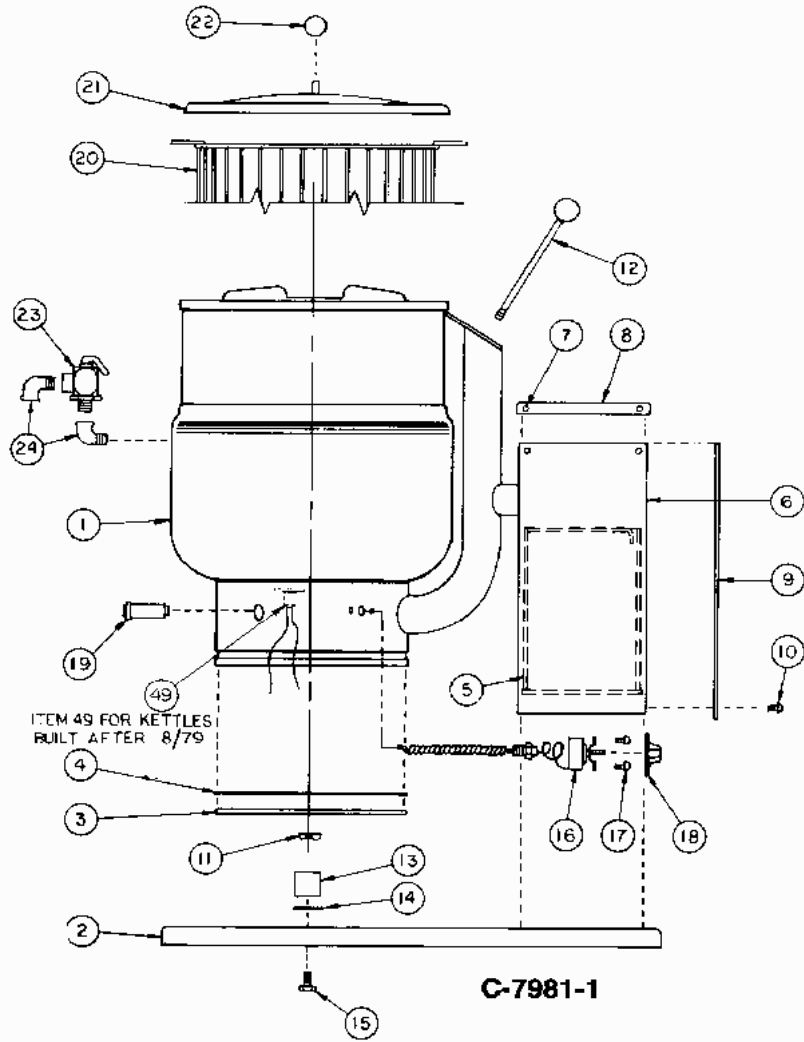

(For units manufactured before September 1, 1998)

OM-TDB/7

Parts List

(For units manufactured between September 1, 1988 and July 1, 1992)*

To order parts, contact your Groen Certified Service Agency. Supply the model designation, part description, part number, quantity, and, where applicable, voltage and phase.

Key	Description	Part No.	Key	Description	Part No.
1	Kettle Assembly TDB/7-20	003144	24	Street el 1/4" IPS X 90"	010668
	Kettle Assembly TDB/7-40	003145	25	Block, Pillow, 1-1/2"	002989
2	Base Assembly	054174	26	Collar, Set	003118
3	Bottom Cover	003141	27	Set Screw 3/8" - 16 NC X 1/2"	003117
4	Gasket, U-channel	007937	28	Micro Switch	002982
5	Pedestal Weldment	002990	29	Bracket, Micro Switch	002988
6	Pedestal Cladding, TDB/7-40	003149	30	Contactora	(See table)
	Pedestal Cladding, TDB/7-20	003147	31	Transformer	086876
7	Screw #8 X 1/2"	005002	32	Fuse, 480v Only	055572
8	Cap, Pedestal	003137	33	Terminal Block	088214
9	Cover, TDB/7-40	003136	34	Fuse Holder 208/240V Only	002944
	Cover, TDB/7-20	003139	35	Fuse 208/240V Only	(See table)
10	Screw, RHMS #8-32 X 3/8"	005724	36	Screw, RHMS #8-32 X 3/4"	012656
11	Nut, KEPS 1/4" X 20 NC	012940	37	Spacer	003146
12	Handle Assembly	012695	38	Screw, Hex Head 1/2" - 13 NC X 3-1/2"	003285
	Ring, Tolerance	012692	39	Nut, Hex 1/2" - 13 NC	005705
13	Bumper, TDB/7-40	003248	40	Lock Washer 1/2"	005735
	Bumper, TDB/7-20	003241	41	Pressure Gauge	001594
14	Washer (As Required)	003242	42	Fittings, Gauge Glass	002845
	Washer (As Required)	003243	43	Rubber Gauge Glass Gasket	008917
15	Screw, Hex Head 1/2" -13 NC X 1"	005622	44	Washer (With Item 42)	—
16	Thermostat	012313	45	Hex Nut (With Item 42)	—
17	Screw, RHMS #6-32 NC X 1/2"	012603	46	Glass, Gauge	002987
18	Knob, Thermostat	002868	47	Rod, Gauge Glass Guard	003127
19	Pilot Light, 208-240V	016028	48	Nut, Dome #10 - 24 NC	005470
	Pilot Light, 480V	002986	49	Thermostat, High Limit	004588
20	Basket for TDB/7-20	001607		Bracket, Bottom	002916
	Basket for TDB/7-40	001121		Grommet, Thermostat	001518
21	Cover, One Piece Lift-off, TDB/7-40	013496		Grommet, Trunnion	003492
	Cover, One Piece Lift-off, TDB/7-20	001566		Grommet	007400
22	Knob, Maroon Ball	012691		Elbow	004185
23	Valve, Safety	005587			

ELECTRICAL PARTS TABLE

Model	KW	AMP	Contactora	Pilot Light	Transformer	Wire Harness	Fuse
TDB/7-20							
208V/1 Ph	6.3	31	013369	016028	NONE	088210	002945
240V/1 Ph	6.3	27	013369	016028	NONE	088210	002945
480V/1 Ph	6.3	14	013369	016028	086876	088210	055572
208V/3 Ph	6.3	18	013369	016028	NONE	088210	002945
240V/3 Ph	6.3	16	013369	016028	NONE	088210	002945
480V/3 Ph	6.3	8	013369	016028	086876	088210	055572
TDB/7-40							
208V/1 Ph	10.8	52	013369	016028	NONE	088210	002945
240V/1 Ph	12	50	013369	016028	NONE	088210	002945
480V/1 Ph	12	25	013369	016028	086876	088210	055572
208V/3 Ph	10.8	30	013369	016028	NONE	088210	002945
240V/3 Ph	12	30	013369	016028	NONE	088210	002945
480V/3 Ph	12	15	013369	016028	086876	088210	055572

* Date of manufacture stamped on National Board data plate.

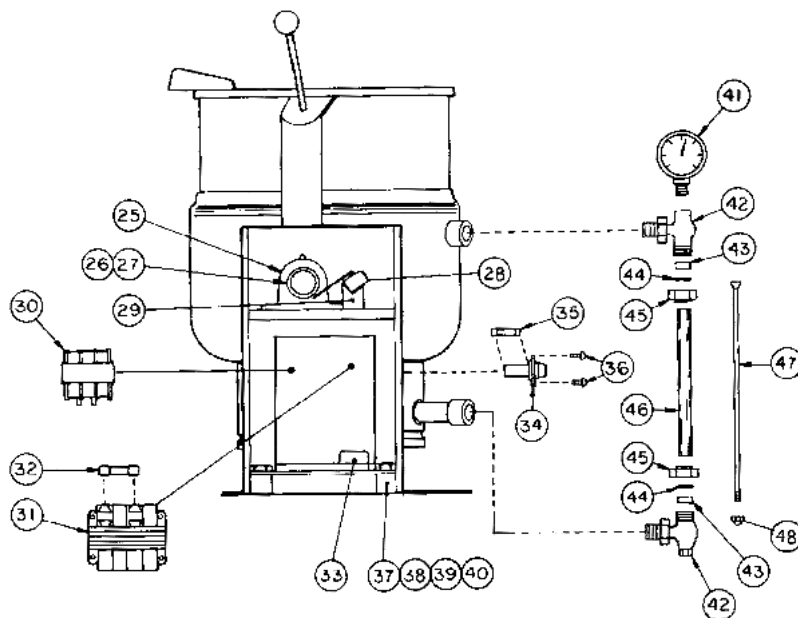
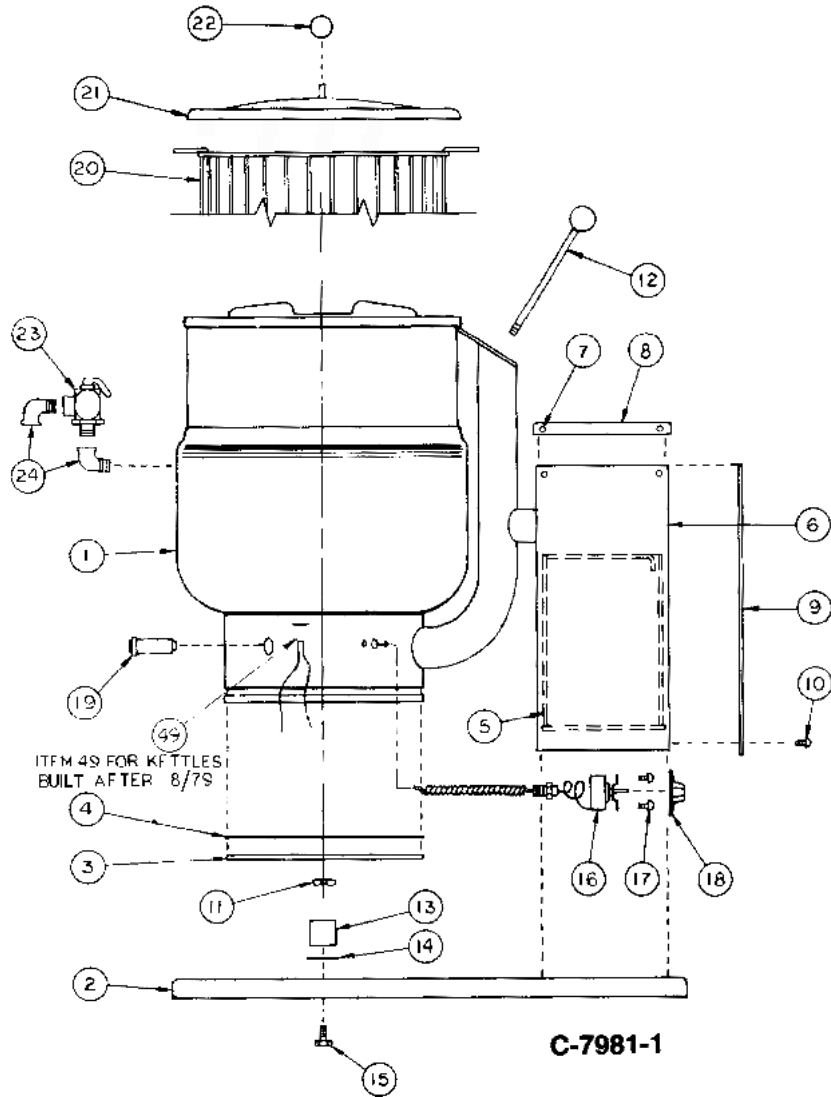

(For units manufactured between September 1, 1988 and July 1, 1992)

OM-TDB/7

Parts List

(For units manufactured between July 1, 1992 and Feb. 6, 1995) *

To order parts, contact your Groen Certified Service Agency. Supply the model designation, part description, part number, quantity, and, where applicable, voltage and phase.

Key	Description	Part No.	Key	Description	Part No.
1	Kettle Assy. TDB/7-20	003144	25	Block, Pillow, 1-1/2"	002989
	Kettle Assy. TDB/7-40	003145	26	Collar, Set	003118
2	Base Assy, TDB/7-20	003135	27	Set Screw 3/8" - 16 NC X 1/2"	003117
	Base Assy, TDB/7-40	003206	28	Micro Switch	002982
3	Bottom Cover	003141	29	Bracket, Micro Switch	002988
4	Gasket, U-channel	007937	30	Contactator	(See table)
5	Pedestal Weldment	002990	31	Transformer 480V Only	(See table)
6	Pedestal Cladding, 480V Only	003148	32	Fuse 3 AMP, 480V Only	(See table)
	Pedestal Cladding, 208-240V	003147	33	Terminal Block	088214
7	Screw #8 X 1/2"	005002	34	Fuse Holder 208-240V	002944
8	Cap	003137	35	Fuse 208/240V	(See table)
9	Cover, TDB/7-40	003136	36	Screw, RHMS #8-32 X 3/4"	012656
	Cover, TDB/7-20	003139	37	Spacer	003146
10	Screw, RHMS #8-32 X 3/8"	005724	38	Screw Hex Head 1/2"-13 NC x 3/2"	003285
11	Nut, KEPS 1/4" X 20 NC	012940	39	Nut, Hex 1/2" - 13 NC	005705
12	Handle	012695	40	Lock Washer 1/2"	005735
13	Bumper, TDB/7-40	003248	41	Pressure Gauge	084208
	Bumper, TDB/7-20	003241	42	Fittings, Gauge Glass	002845
14	Washer (As Required)	003242	43	Rubber Gauge Glass Gasket	008917
	Washer (As Required)	003243	44	Washer (With Item 42)	—
15	Screw Hex Head 1/2"-13 NC X 1"	005622	45	Hex Nut (With Item 42)	—
16	Thermostat	012313	46	Glass, Gauge	002987
17	Screw, RHMS #6-32 NC X 1/2"	012603	47	Rod, Gauge Glass Guard	003127
18	Knob, Thermostat	002868	48	Nut, Dome #10 - 24 NC	005470
19	Pilot Light	(See table)	49	Thermostat, High Limit	004588
20	Basket	—	50	1/4 NPT Full Coupling	093306
21	Cover	—	51	1/4 NPT Nipple X 2" Long	010281
22	Knob	—	—	Water Fill Assy.	096914
23	Valve, Safety	097005	—	Water Level Probe	015589
24	Street EL 1/4" IPS X 90"	010668	—	Low Water Cutoff 208V/240V/480V	096925

ELECTRICAL PARTS TABLE

Model	KW	AMP	Contactator	Pilot Light	Transformer	Wire Harness	Fuse
TDB/7-20							
208V/1 Ph	6.3	31	013369	016028	NONE	083649	002945
240V/1 Ph	6.3	27	013369	016028	NONE	083649	002945
480V/1 Ph	6.3	14	013369	016028	086876	083649	086881
208V/3 Ph	6.3	18	013369	016028	NONE	083649	002945
240V/3 Ph	6.3	16	013369	016028	NONE	083649	002945
480V/3 Ph	6.3	8	013369	016028	086876	083649	086881
TDB/7-40							
208V/1 Ph	10.8	52	013369	016028	NONE	083649	002945
240V/1 Ph	12	50	013369	016028	NONE	083649	002945
480V/1 Ph	12	25	013369	016028	086876	083649	086881
208V/3 Ph	10.8	30	013369	016028	NONE	083649	002945
240V/3 Ph	12	30	013369	016028	NONE	083649	002945
480V/3 Ph	12	15	013369	016028	086876	083649	086881

* Date of manufacture stamped on National Board data plate.

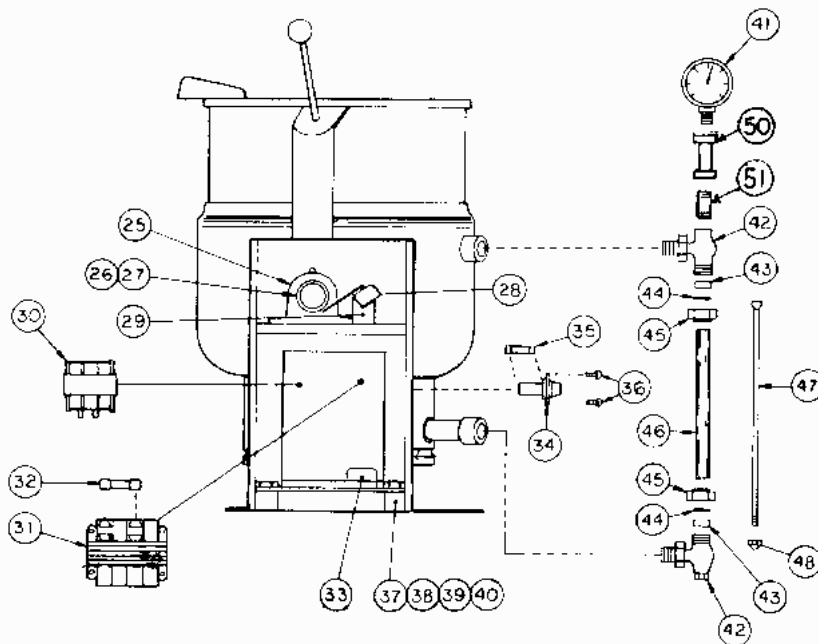
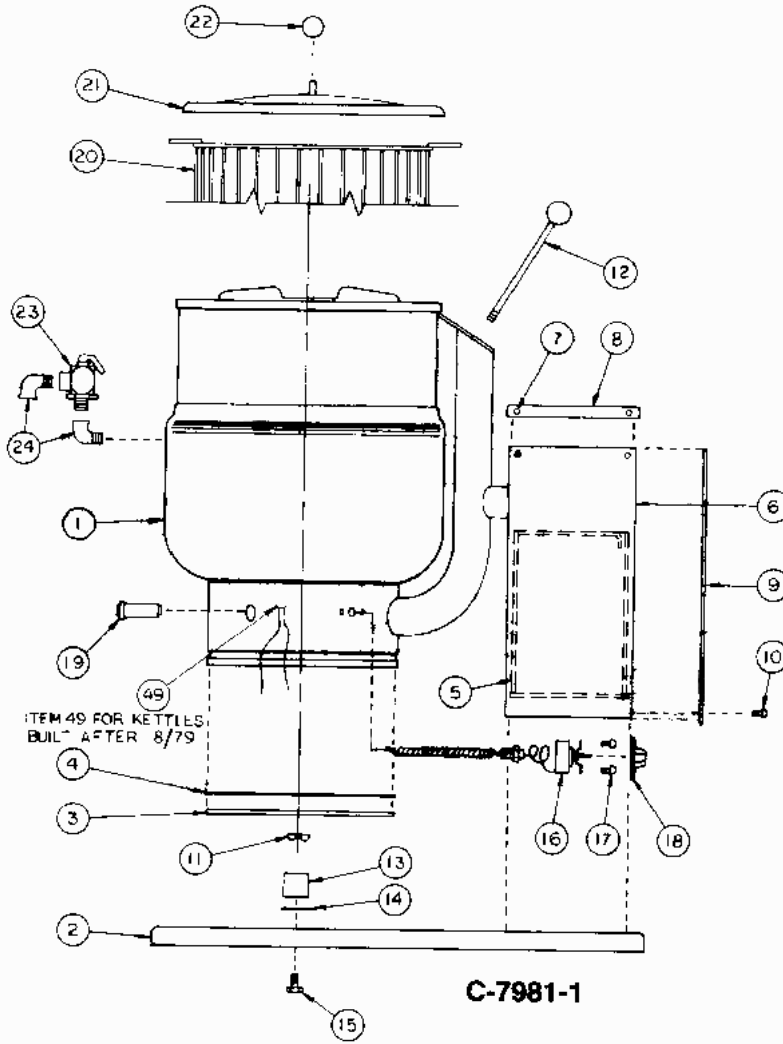

(For units manufactured ~~between~~ July 1, 1992 and February 6, 1995)*

Replacement Kettle Body Parts List

(For units manufactured *after* Feb. 6, 1995) *

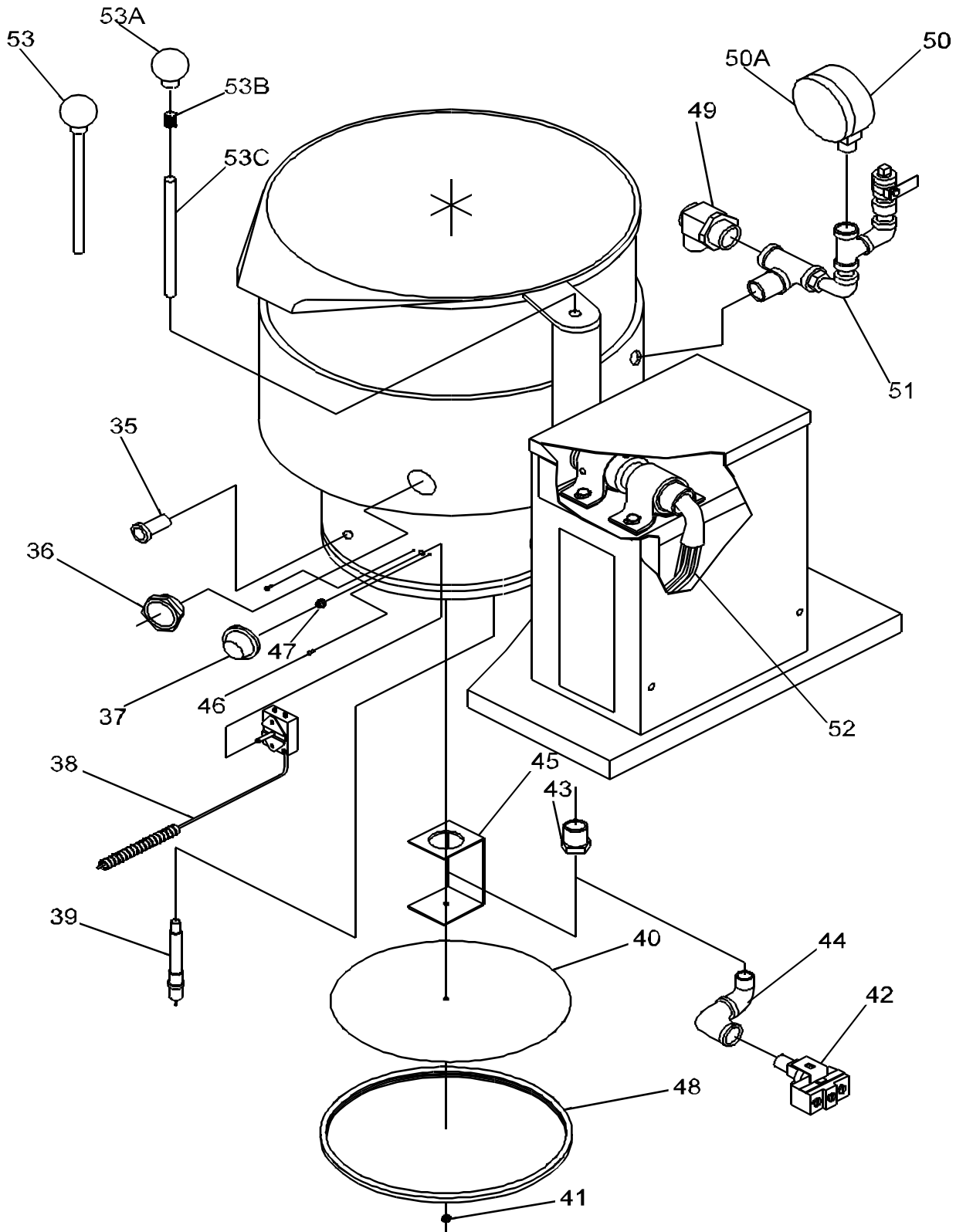

* Date of manufacture stamped on National Board data plate.

Replacement Mechanical Parts List

(For units manufactured *after* Feb. 6, 1995) *

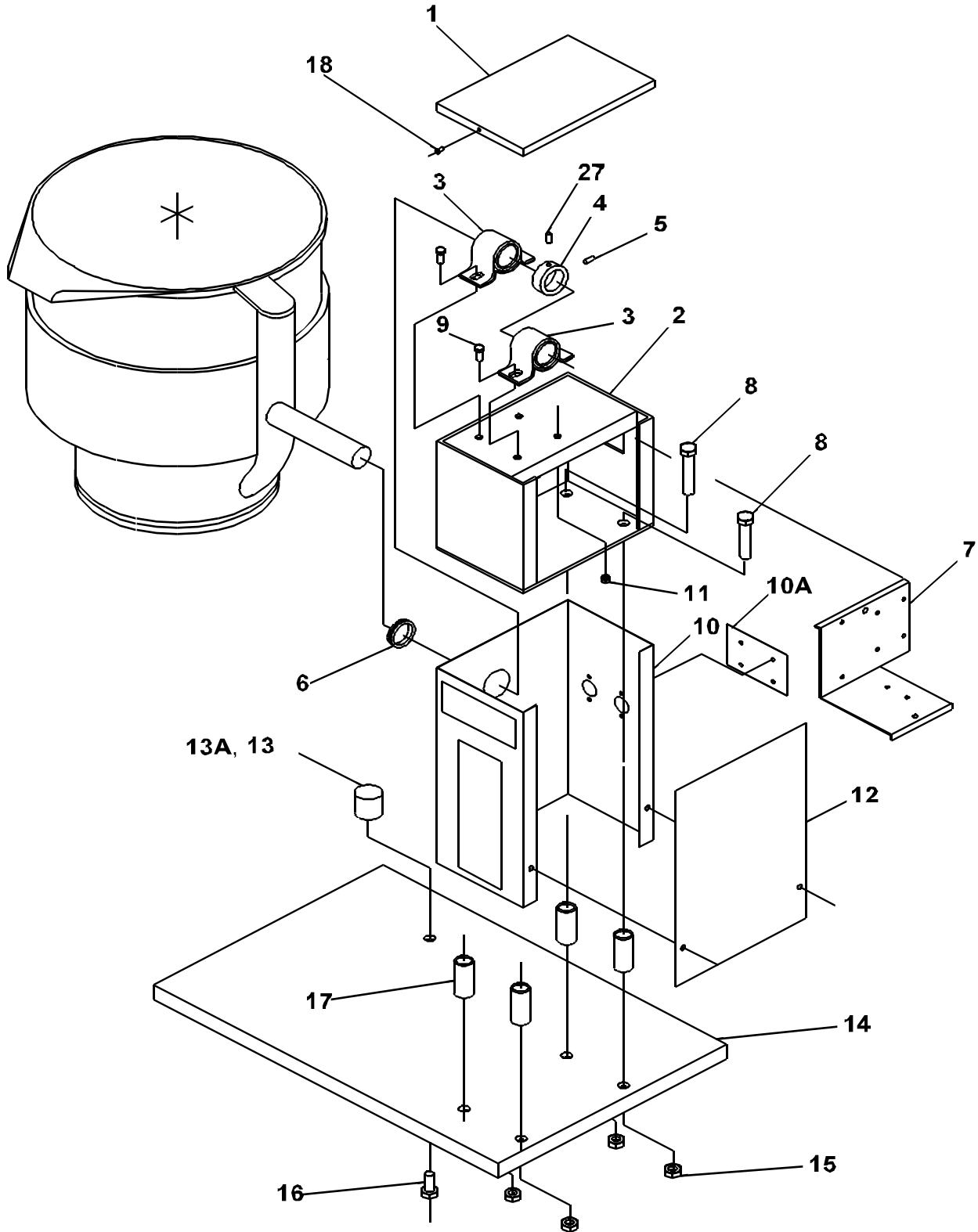

* Date of manufacture stamped on National Board data plate.

Replacement Electrical Parts List

(For units manufactured *after* Feb. 6, 1995)

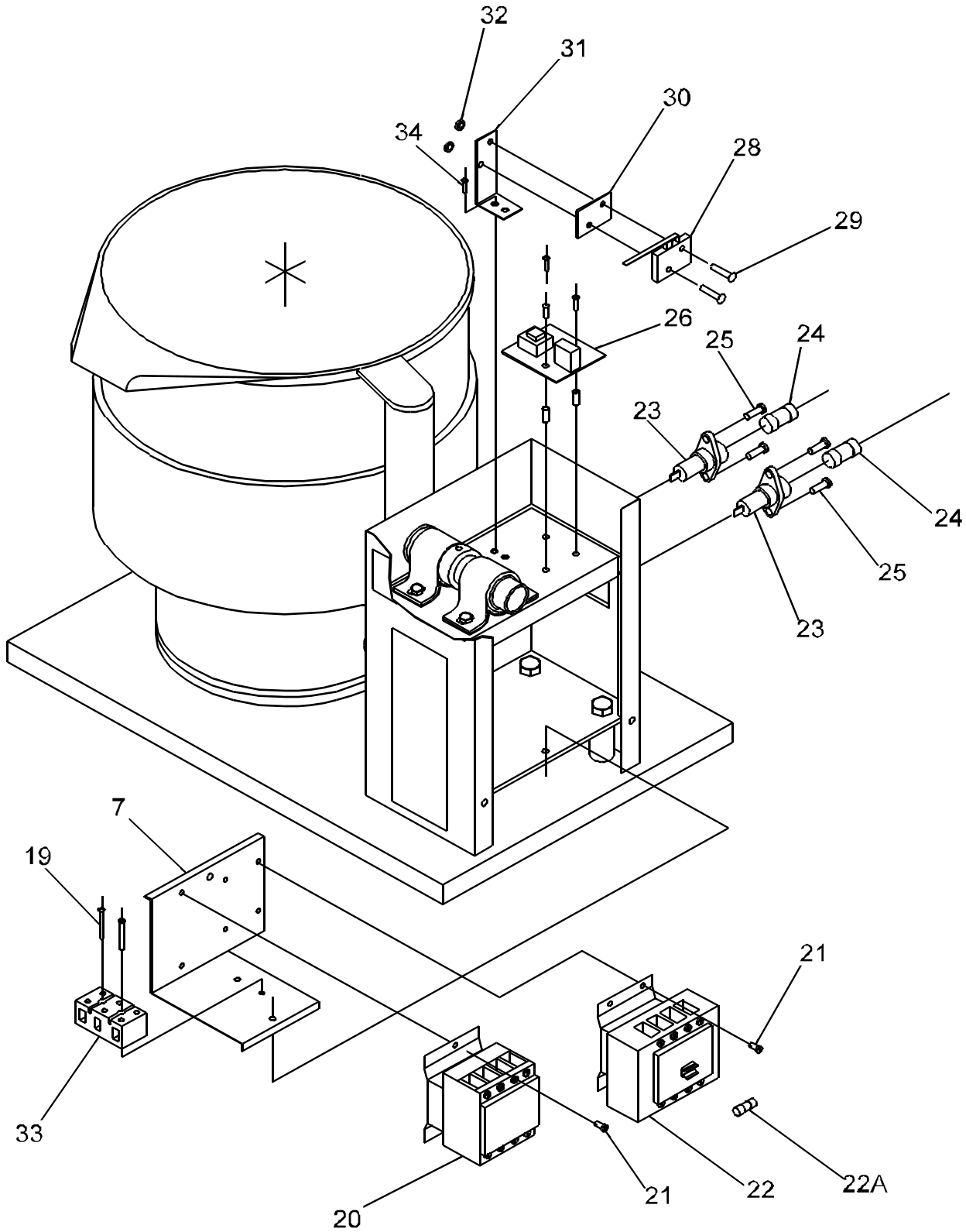

* Date of manufacture stamped on National Board data plate.

Parts List

(For units manufactured after Feb. 6, 1995) *

To order parts, contact your Groen Certified Service Agency. Supply the model designation, part description, part number, quantity, and, where applicable, voltage and phase.

Key	Description	Part No.	Key	Description	Part No.
1	Pedestal Cover	003137	30	Insulator Board	003490
2	Pedestal Weldment	002990	31	Tilt Switch Bracket	002982
3	Pillow Block	002989	32	Hex Nut #4-40	003121
4	Set Collar	003118	33	Terminal Block	088214
5	Set Screw 5/8" LG	003440	34	Screw #6-32 X 1/2" LG	012603
6	Grommet	003492	35	Pilot Lamp	016028
7	Electrical Mounting Bracket	086873	36	Bullseye Sightglass	108554
8	Bolt 1/2-13 X 3-1/2" LG	003285	37	Thermostat Knob	002868
9	Bolt 3/8 - 16 X 1-1/2" LG	005703	38	Thermostat	012313
10	Pedestal Cladding 208/240 Volt	003147	39	Water Level Probe	015589
10A	Cover Plate 480 Volt Fuse Holders	088212	40	Bottom Cover	003141
11	Hex Nut 3/8 - 16	008214	41	Hex Nut 1/4-20	012940
12	Pedestal Cover	003139	42	Pressure Switch	096963
13	Bumper TDB/7-20	101560	43	Hex Reducing Bushing 1/2 NPT x 1/4 NPT	008739
13A	Bumper TDB/7-40	003268	44	Elbow Assembly	101543
14	Base Assembly	054174	45	Bottom Cover Bracket	002916
15	Hex Nut 1/2-13	005705	46	Screw #6-32 X 3/8" LG Round Head	009697
16	Bolt 1/2-13 X 3/4" LG	005070	47	Thermostat Adapter	107172
17	Weldment Spacer	003146	48	Gasket Bottom Cover	007937
18	Sheet Metal Screw #8 Truss Hd.	005002	49	Safety Valve	097005
19	Screw #8-32 X 1-1/4" LG	005056	50	Pressure Gauge	084208
20	Contactora	013369	50A	Pressure Gauge Lens	087635
21	Screw #8-32 X 3/8" LG	006971	51	Water Fill Assembly	101528
22	Transformer 480 Volt	086876	52	Kettle Body Wire Harness	096938
22A	Fuse 480 Volt Only	086881	53	Handle Assembly	012695
23	Fuse Holder	002944	53A	Ball Knob	012691
24	Fuse	002945	53B	Tolerance Ring	012692
25	Screw #8-32 X 3/4" LG.	012656	53C	Handle Rod	013597
26	Water Level Control Board	096925	x	Nickel Plt Heating Element Nut	084202
27	Set Screw 1/2" LG	003117	x	Nickel Plt Heating Element Screw	084201
28	Tilt Screw	002982	x	Line Side Harness	088210
29	Screw #4-40 X 3/4" LG	003122			

* Date of manufacture stamped on National Board data plate.

x - Not Shown

Wiring Diagrams

For units manufactured *before* September 1, 1988

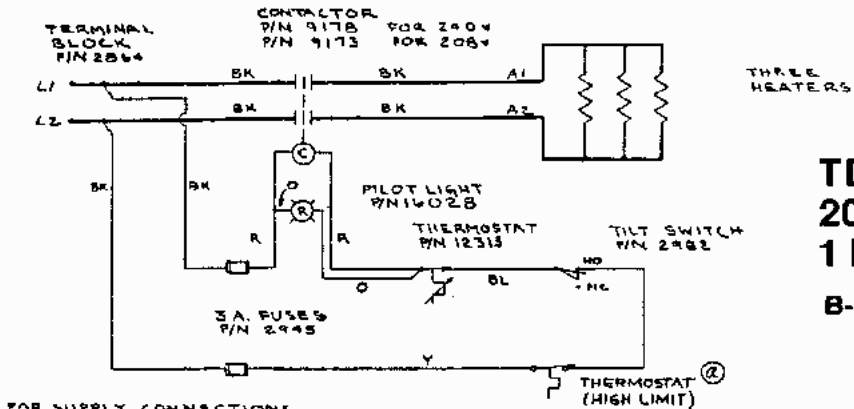

TDB/7-20
208-240 V
1 PH
B-7981-32

FOR SUPPLY CONNECTIONS
 USE COPPER WIRE ONLY

208V 1P/1 50/60HZ 6.3KW 31AMP
 240V 1P/1 50/60HZ 6.3KW 27AMP

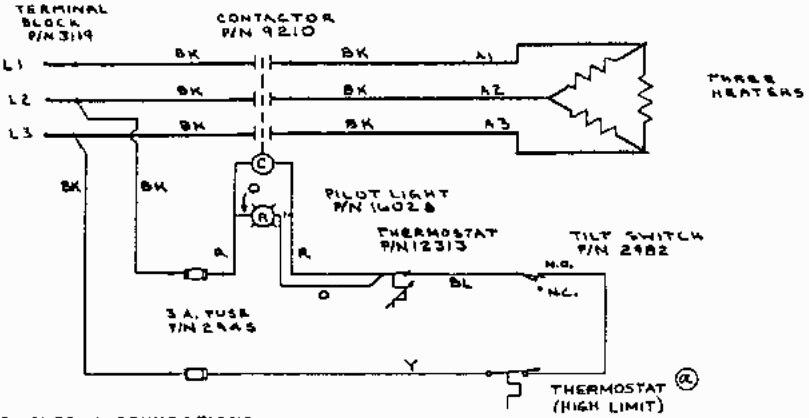

TDB/7-20
208-240 V
3 PH
B-7981-34

FOR SUPPLY CONNECTIONS
 USE COPPER WIRE ONLY

208V 3PH 50/60HZ 6.3KW 18AMP
 240V 3PH 50/60HZ 6.3KW 16AMP

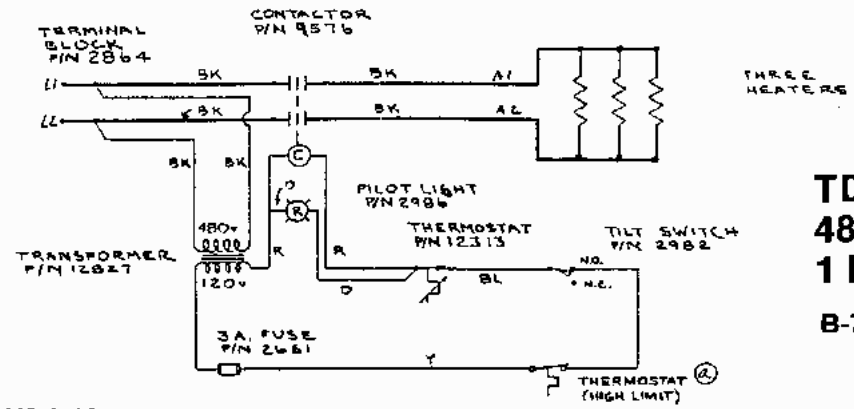

TDB/7-20
480 V
1 PH
B-7981-33

FOR SUPPLY CONNECTIONS
 USE COPPER WIRE ONLY

480V 1PH 50/60HZ 6.3KW 14AMP

Wiring Diagrams

For units manufactured *before* September 1, 1988

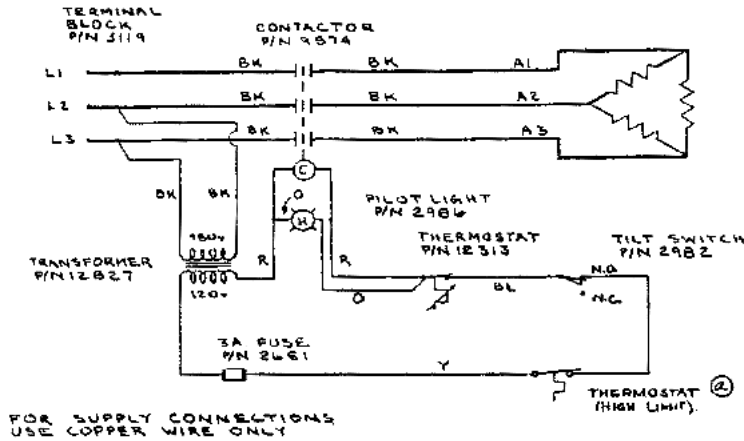

TDB/7-20
480 V
3 PH
B-7981-35

FOR SUPPLY CONNECTIONS
 USE COPPER WIRE ONLY

480V 3PH 50/60HZ 6.3KW 8AMP

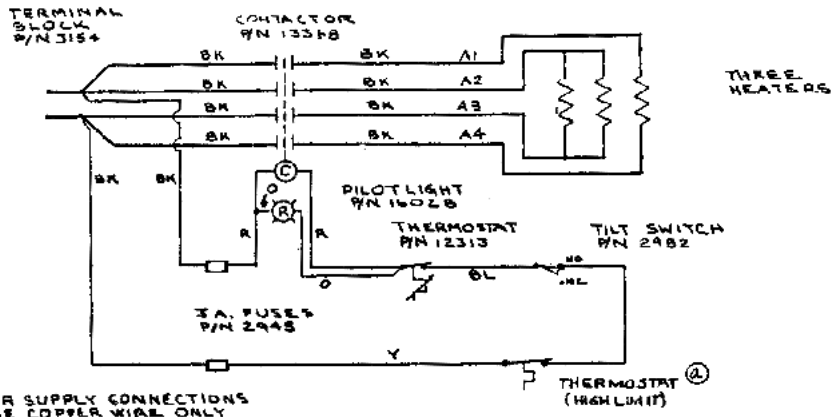

TDB/7-40
208-240 V
1 PH
B-7981-28

FOR SUPPLY CONNECTIONS
 USE COPPER WIRE ONLY

208V 1PH 50/60HZ 10.8KW 52AMP
 220/240V 1PH 50/60HZ 12KW 50AMP

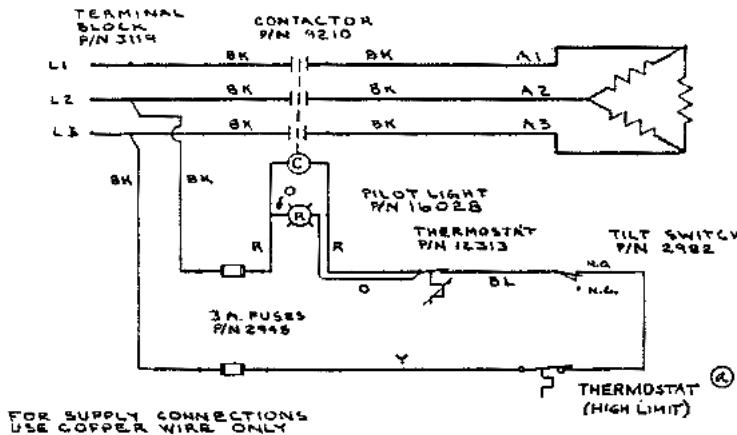

TDB/7-40
208-240 V
3 PH
B-7981-30

FOR SUPPLY CONNECTIONS
 USE COPPER WIRE ONLY

208V 3PH 50/60HZ 10.8KW 30AMP
 240V 3PH 50/60HZ 12KW 30AMP

Wiring Diagrams

For units manufactured *before* September 1, 1988

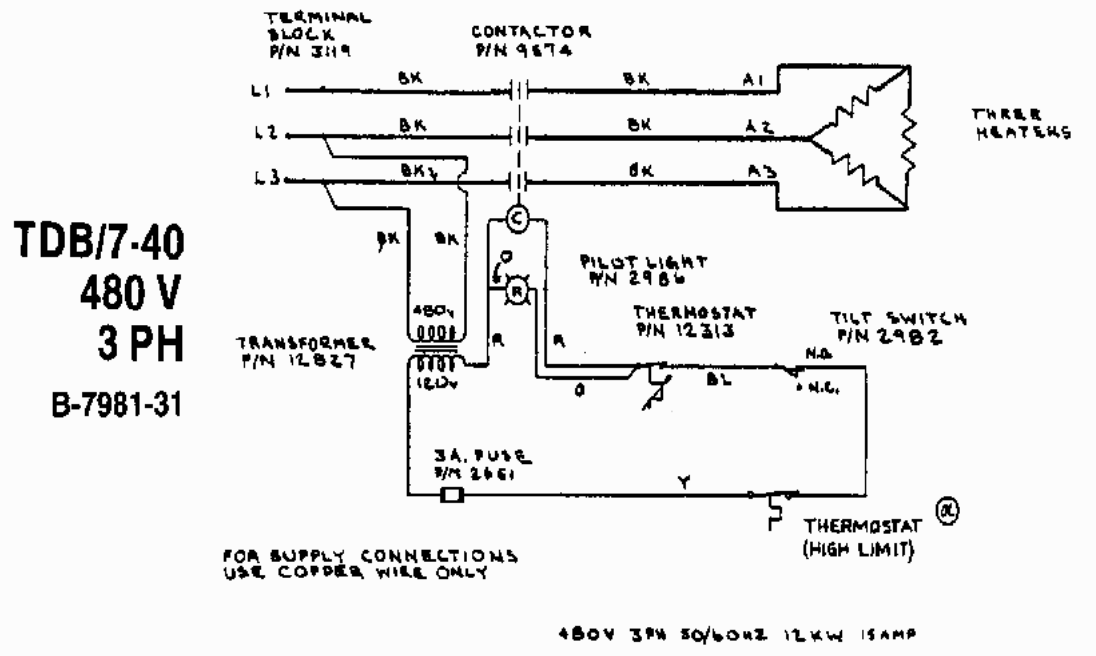
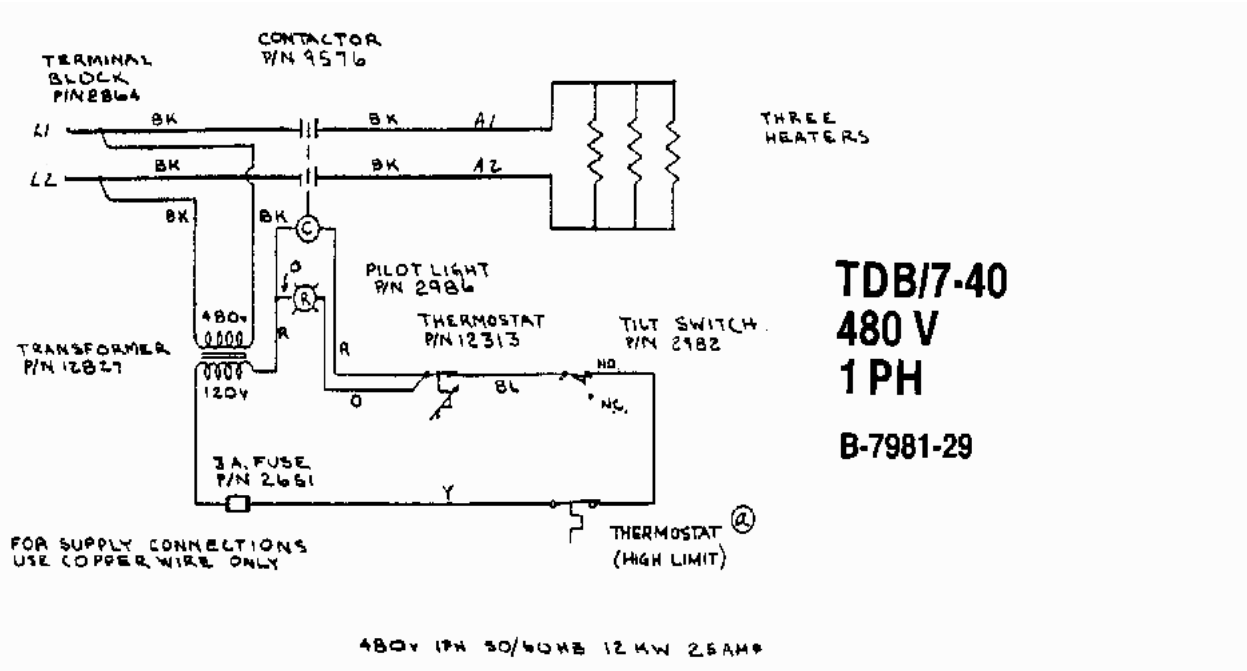

Wiring Diagrams

For units manufactured *after* September 1, 1988 and *before* June 1, 1990

TDB/7-20
208-240 V
1 PH
B-7981-32

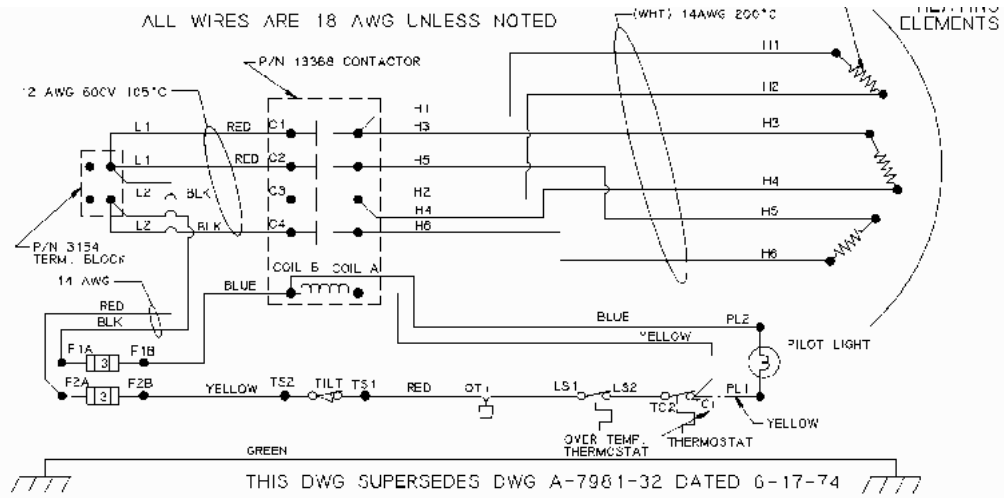

TDB/7-20
208-240 V
3 PH
B-7981-34

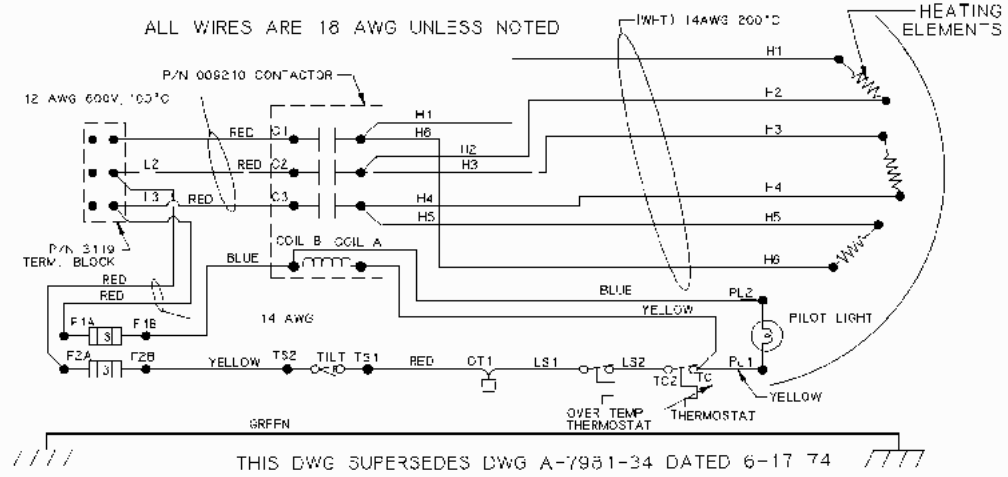

TDB/7-20
480 V
1 PH
B-7981-33

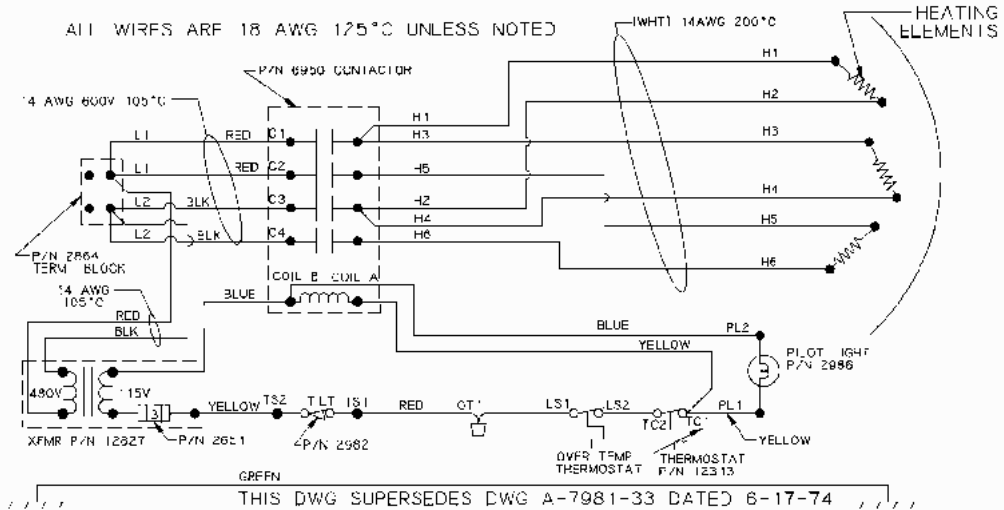

Wiring Diagrams

For units manufactured *after* September 1, 1988 and before June 1, 1990

TDB/7-20
480 V
3 PH

B-7981-35

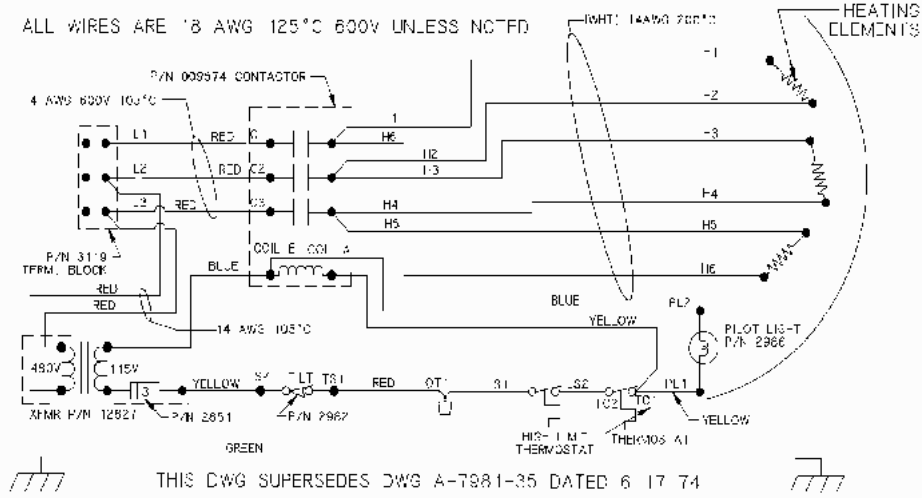

TDB/7-40
208-240 V
1 PH

B-7981-28

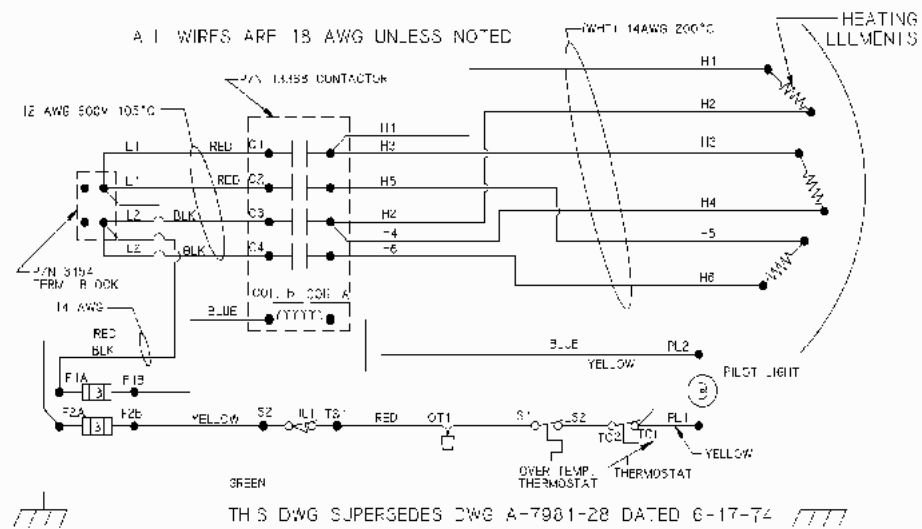

TDB/7-40
208-240 V
3 PH

B-7981-30

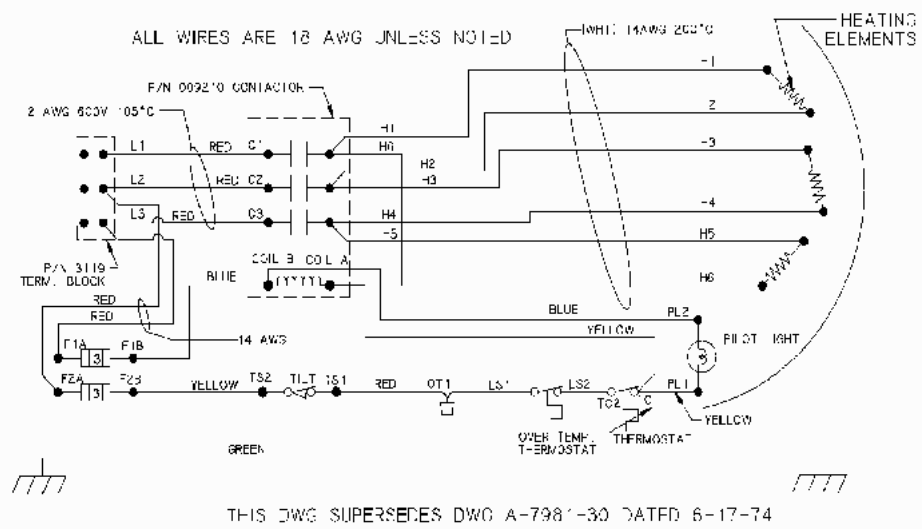

Wiring Diagrams

For units *manufactured after September 1, 1988 and before June 1, 1990*

TDB/7-40
480 V
3 PH
B-7981-29

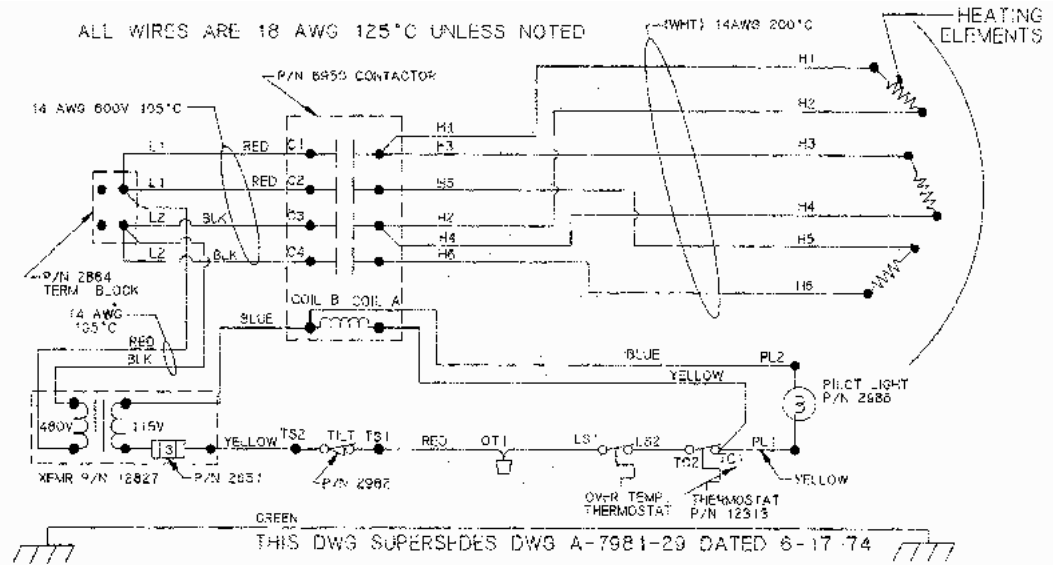

TDB/7-40
480 V
1 PH
B-7981-31

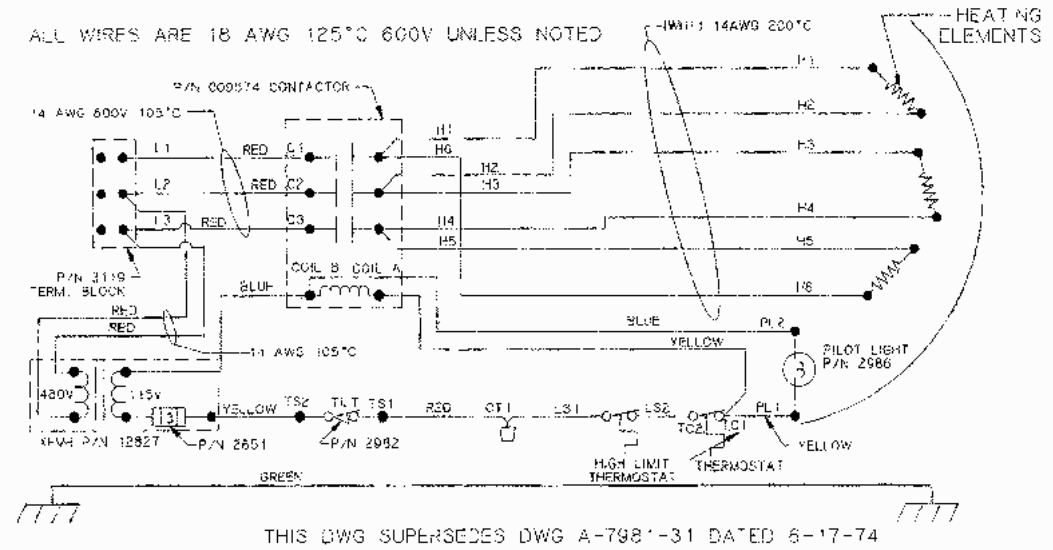

Wiring Diagrams

For units manufactured *after June 1, 1990 and before July 1, 1992*

**TDB/7-20 &
TDB/7-40
208-240 V
1 & 3 PH
B-7981-803**

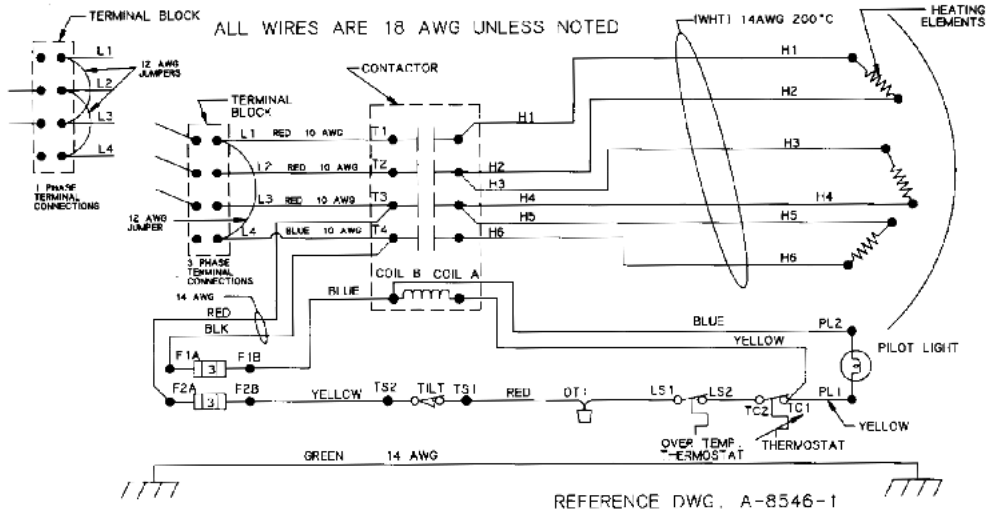

**TDB/7-20 &
TDB/7-40
380/415 V
3 PH
B-7981-802**

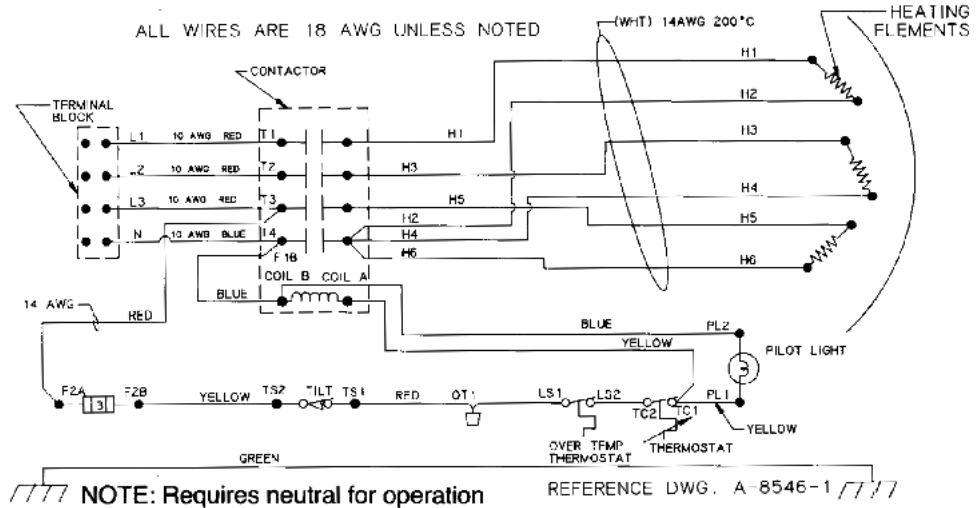

**TDB/7-20 &
TDB/7-40
480 V
1 & 3 PH
B-7981-804**

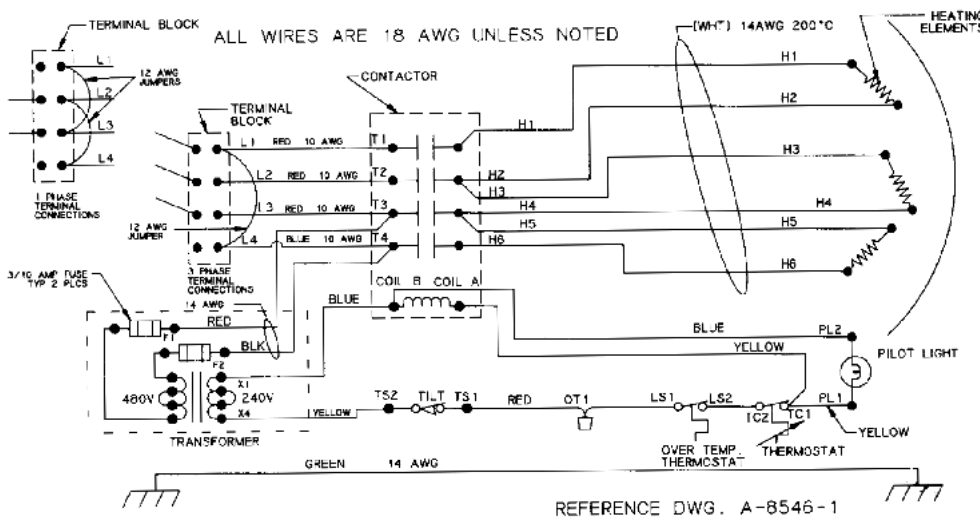

Wiring Diagrams

For units manufactured *after* June 1, 1990 and *before* February 6, 1995

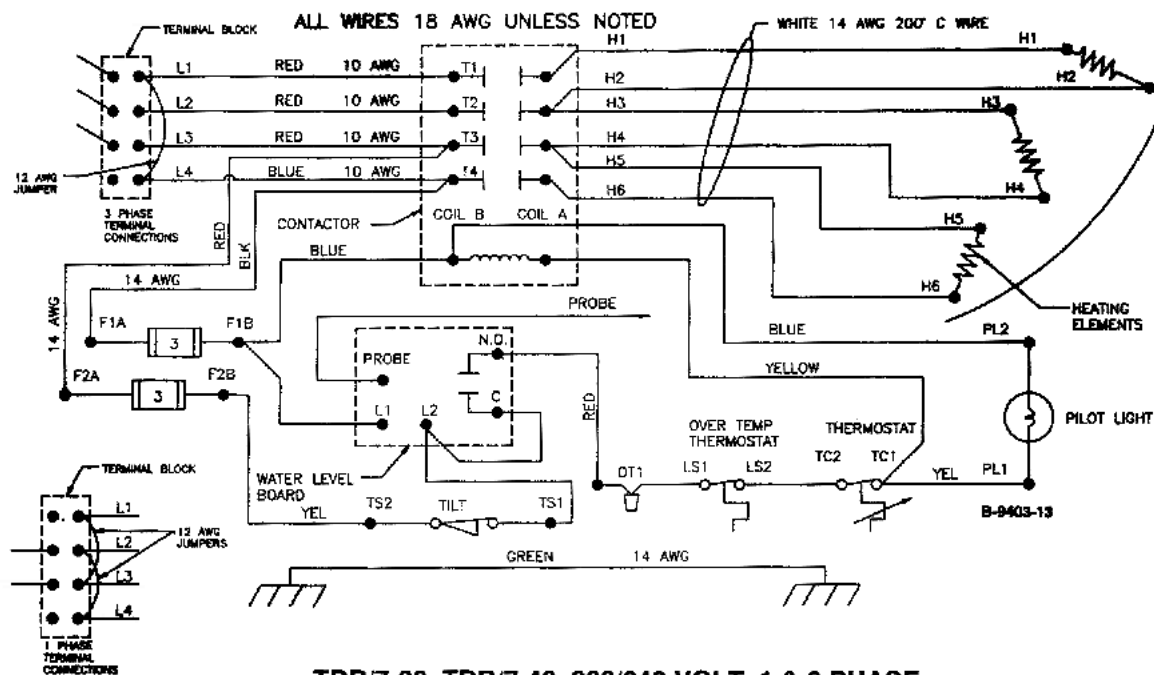

TDB/7-20, TDB/7-40, 208/240 VOLT, 1 & 3 PHASE

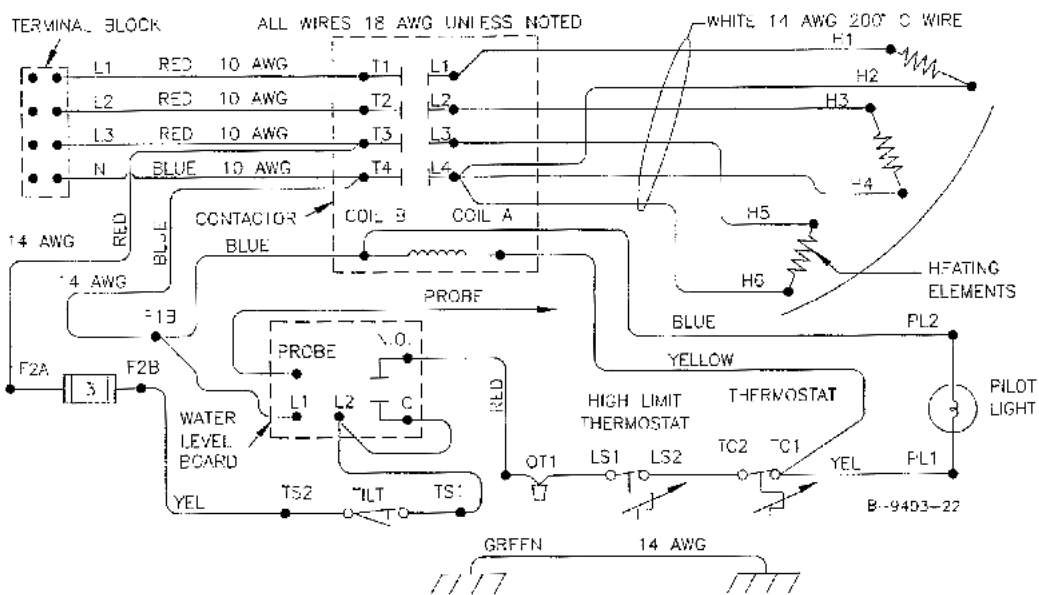

TDB/7-20, TDB/7-40, 380/415 VOLT, 3 PHASE W/NEUTRAL

Wiring Diagrams

For units manufactured *after July 1, 1992 and before February 6, 1995*

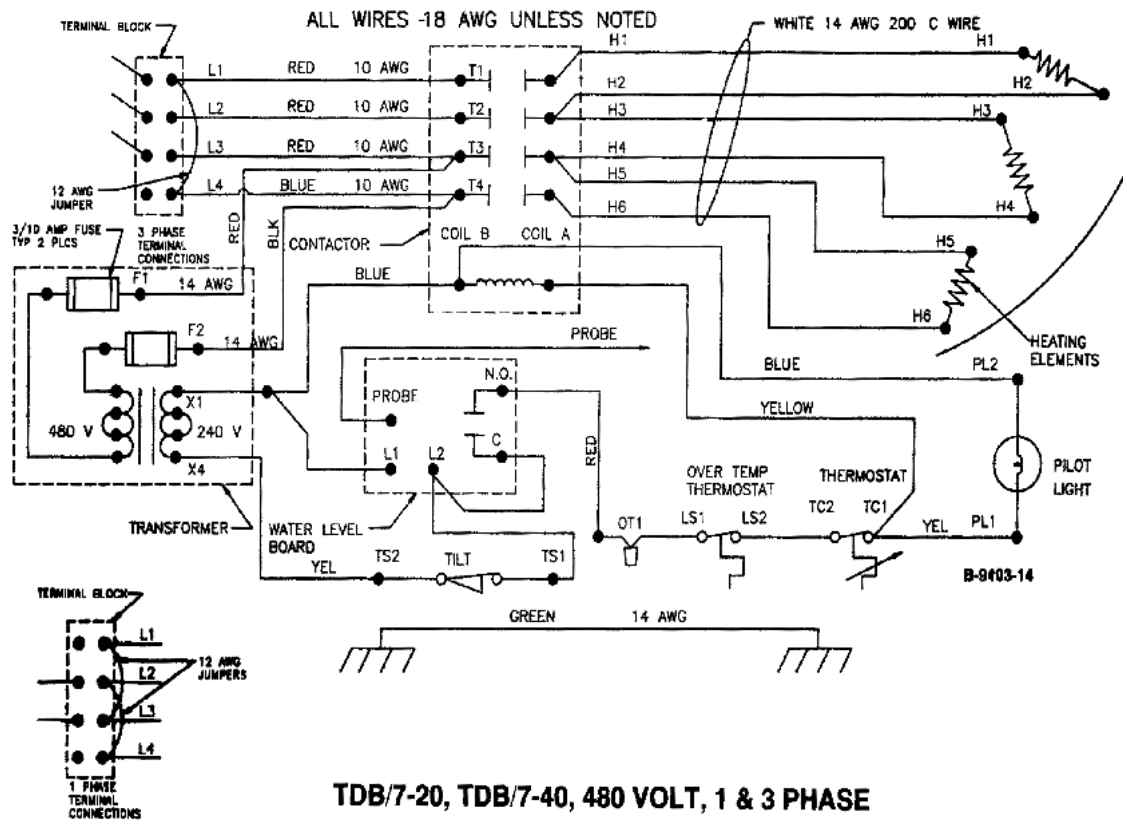

Wiring Diagrams

For units manufactured *after* Feb. 6, 1995

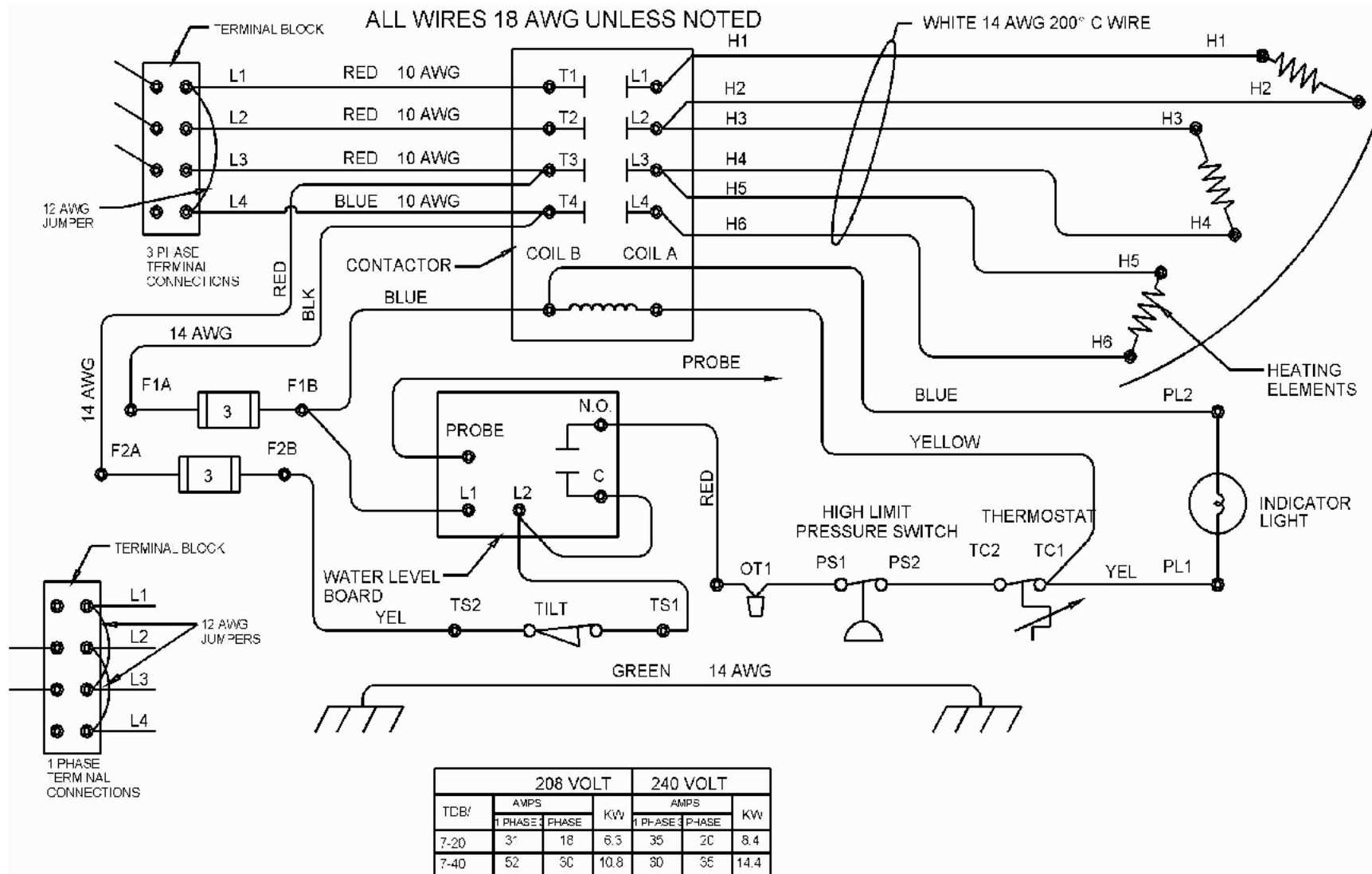

TDB/7-20, TDB/7-40
208/240 Volt, 1 and 3 Phase

Wiring Diagrams

For units manufactured *after* Feb. 6, 1995

OM-TDB/7

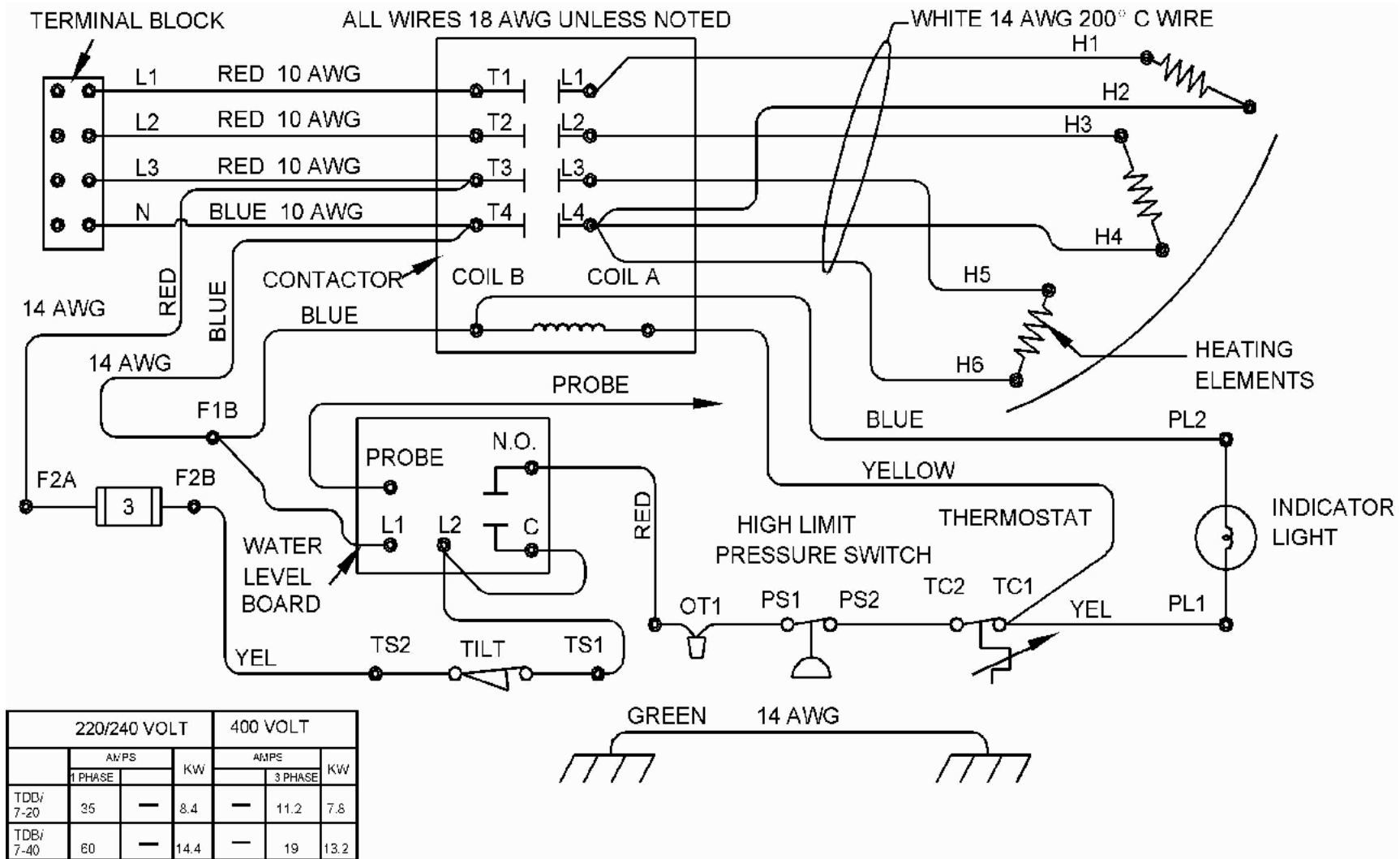

TDB/7-20, TDB/7-40
230 Volt 1 Phase and 400 Volt 3 Phase
(International Units)

Wiring Diagrams

For units manufactured *after Feb. 6, 1995*

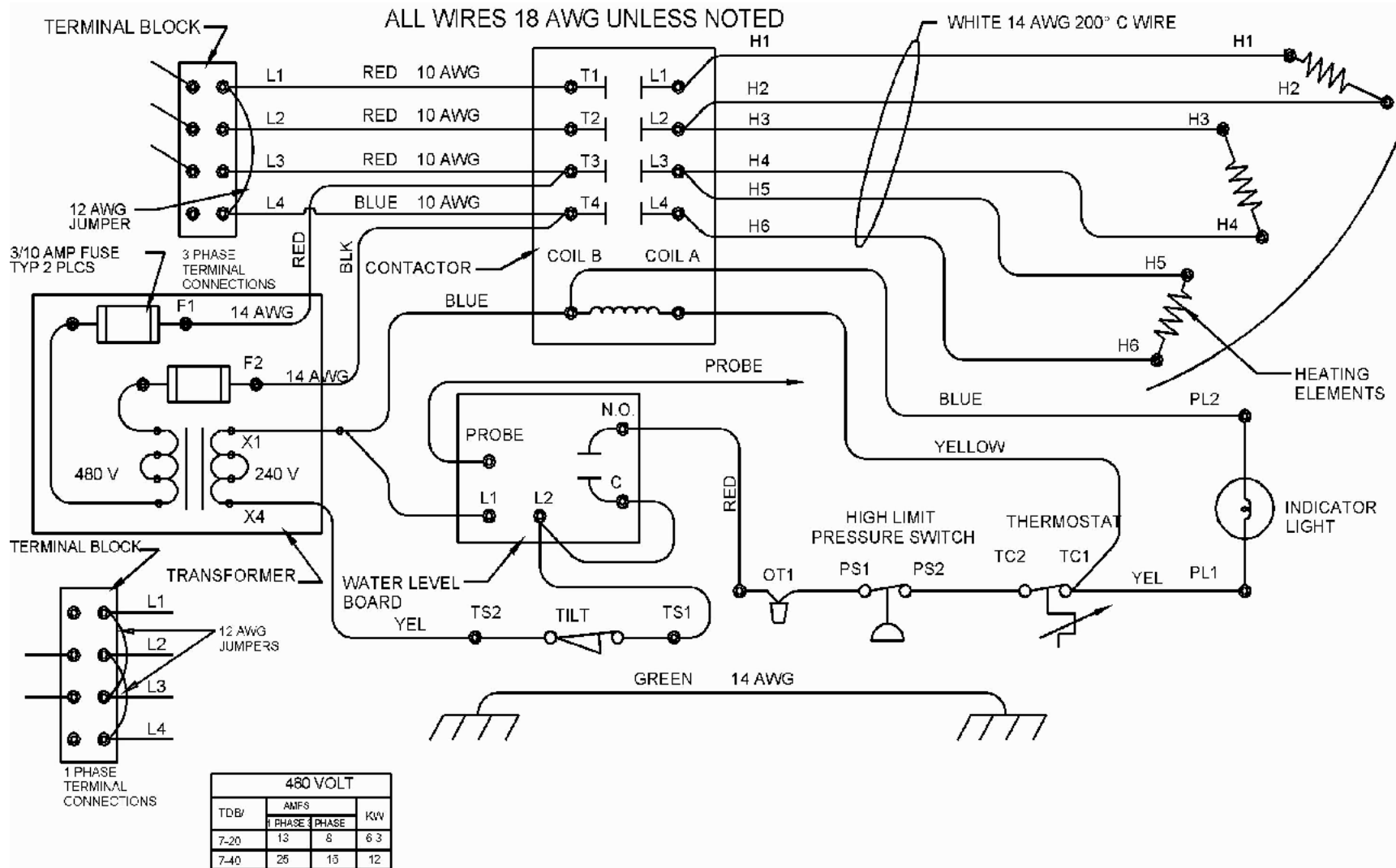

TDB/7-20, TDB/7-40
480 VOLT, 1 & 3 PHASE

OM-TDB/7

Service Log

Model No. _____ Purchased From _____

Serial No. _____ Location _____

Date Purchased _____ Date Installed _____

Purchase Order No. _____ For Service Call _____

Date	Service Performed	Performed By

References

KLENZADE SALES CENTER ECOLAB. Inc.
370 Wabasha
St. Paul, Minnesota 55102
800/352-5326 or 612/293-2233

NATIONAL FIRE PROTECTION ASSOCIATION
60 Battery March Park
Quincy, Massachusetts 02269

NFPA/54 - Installation of Gas Appliances & Gas Piping
NFPA/70 - The National Electrical Code

NATIONAL SANITATION FOUNDATION
3475 Plymouth Rd.
Ann Arbor, Michigan 48106

UNDERWRITERS LABORATORIES, INC.
333 Pfingsten Road
Northbrook, Illinois 60062

ZEP MANUFACTURING CO.
1310-T Seaboard Industrial Blvd.
Atlanta, Georgia 30318

**Limited Warranty
To Commercial Purchasers ***

**(Domestic U.S., Hawaii &
Canadian Sales Only)**

Groen Foodservice Equipment ("Groen Equipment") has been skillfully manufactured, carefully inspected and packaged to meet rigid standards of excellence. Groen warrants its Equipment to be free from defects in material and workmanship for (12) twelve months with the following conditions and subject to the following limitations.

- I. This parts and labor warranty is limited to Groen Equipment sold to the original commercial purchaser/users (but not original equipment manufacturers), at its original place of installation in the continental United States, Hawaii and Canada.
- II. Damage during shipment is to be reported to the carrier, is not covered under this warranty, and is the sole responsibility of purchaser/user.
- III. Groen, or an authorized service representative, will repair or replace, at Groen's sole election, any Groen Equipment, including but not limited to, drawoff valves, safety valves, gas and electric components, found to be defective during the warranty period. As to warranty service in the territory described above, Groen will absorb labor and portal to portal transportation costs (time & mileage) for the first twelve (12) months from date of installation or fifteen (15) months from date of shipment from Groen.
- IV. This warranty does not cover boiler maintenance, calibration, periodic adjustments as specified in operating instructions or manuals, and consumable parts such as scraper blades, gaskets, packing, etc., or labor costs incurred for removal of adjacent equipment or objects to gain access to Groen Equipment. This warranty does not cover defects caused by improper installation, abuse, careless operation, or improper maintenance of equipment. This warranty does not cover damage caused by poor water quality or improper boiler maintenance.
- V. **THIS WARRANTY IS EXCLUSIVE AND IS IN LIEU OF ALL OTHER WARRANTIES, EXPRESSED OR IMPLIED, INCLUDING ANY IMPLIED WARRANTY OF MERCHANTABILITY OR FITNESS FOR A PARTICULAR PURPOSE, EACH OF WHICH IS HEREBY EXPRESSLY DISCLAIMED. THE REMEDIES DESCRIBED ABOVE ARE EXCLUSIVE AND IN NO EVENT SHALL GROEN BE LIABLE FOR SPECIAL, CONSEQUENTIAL OR INCIDENTAL DAMAGES FOR THE BREACH OR DELAY IN PERFORMANCE OF THIS WARRANTY.**
- VI. Groen Equipment is for commercial use only. If sold as a component of another (O.E.M.) manufacturer's equipment, or if used as a consumer product, such Equipment is sold AS IS and without any warranty.

*** (Covers All Foodservice Equipment Ordered After October 1, 1995)**



1055 Mendell David Drive
Jackson, MS 39272
Telephone 601 372-3903
Fax 601 373-9587

OM-TDB/7 (Revised 12/97)
Part Number 121002