

★ **IMPORTANT INFORMATION** ★ **KEEP FOR OPERATOR** ★ **IMPORTANT INFORMATION** ★

OPERATOR MANUAL

Part Number 141762 Revision A

OM-VRC-3E/VRC-6E

DOMESTIC

MODELS: VRC-3E, VRC-6E
Vortex™
**Atmospheric Connectionless
Steamer**

*Self-Contained
Electric Heated*

Capacity: 3 Steamer Pans [per cavity] (VRC-3E)
6 Steamer Pans [per cavity] (VRC-6E)



THIS MANUAL MUST BE RETAINED FOR FUTURE REFERENCE. READ, UNDERSTAND AND FOLLOW THE INSTRUCTIONS AND WARNINGS CONTAINED IN THIS MANUAL.

**FOR YOUR SAFETY
DO NOT STORE OR USE GASOLINE OR OTHER FLAMMABLE VAPORS AND LIQUIDS IN THE VICINITY OF THIS OR ANY OTHER APPLIANCE.**



Information contained in this document is known to be current and accurate at the time of printing/creation. Unified Brands recommends referencing our product line websites, unifiedbrands.net, for the most updated product information and specifications.



IMPORTANT — READ FIRST — IMPORTANT

- WARNING:** WHEN YOU OPEN THE DOOR, STAY AWAY FROM STEAM COMING OUT OF THE UNIT. STEAM CAN CAUSE BURNS.
- WARNING:** BEFORE CLEANING THE OUTSIDE OF THE STEAMER, DISCONNECT THE ELECTRIC POWER SUPPLY. KEEP WATER AND CLEANING SOLUTIONS OUT OF CONTROLS AND ELECTRICAL COMPONENTS. NEVER HOSE OR STEAM CLEAN ANY PART OF THE UNIT.
- WARNING:** ALLOW COOKING CHAMBER TO COOL BEFORE CLEANING.
- WARNING:** DO NOT MOVE THE UNIT WITH WATER IN THE CAVITY OR DRAIN PAN.
- WARNING:** ALLOW WATER IN DRAIN PAN TO COOL BEFORE EMPTYING.
- WARNING:** DO NOT PUT HANDS OR TOOLS INTO THE COOKING CHAMBER UNTIL THE FAN HAS STOPPED TURNING.
- WARNING:** DO NOT OPERATE THE UNIT UNLESS THE REMOVABLE RIGHT SIDE PANEL HAS BEEN RETURNED TO ITS PROPER LOCATION.
- WARNING:** USE OF ANY REPLACEMENT PARTS OTHER THAN THOSE SUPPLIED BY GROEN OR THEIR AUTHORIZED DISTRIBUTOR VOIDS ALL WARRANTIES AND CAN RESULT IN BODILY INJURY TO THE OPERATOR AND DAMAGE THE EQUIPMENT. SERVICE BY OTHER THAN FACTORY-AUTHORIZED PERSONNEL WILL VOID ALL WARRANTIES.
- WARNING:** HIGH VOLTAGE EXISTS INSIDE CONTROL COMPARTMENTS. DISCONNECT FROM BRANCH CIRCUIT BEFORE SERVICING. FAILURE TO DO SO CAN RESULT IN SERIOUS INJURY OR DEATH.
- WARNING:** DO NOT USE CHEMICALS OTHER THAN MILD DETERGENTS TO CLEAN THE COOKING CHAMBER.
- WARNING:** CAREFULLY READ THE OPERATION INSTRUCTION LABEL BEFORE OPERATION OF THE UNIT.
- CAUTION:** SHIPPING STRAPS ARE UNDER TENSION AND CAN SNAP BACK WHEN CUT.
- CAUTION:** DO NOT INSTALL UNITS WITHIN 2 INCHES OF A HEAT SOURCE SUCH AS A BRAISING PAN, DEEP FRYER, CHAR BROILER OR KETTLE.
- NOTICE:** DO NOT USE ANY DE-GREASER THAT CONTAINS POTASSIUM HYDROXIDE OR SODIUM HYDROXIDE OR THAT IS ALKALINE.

Table of Contents

OPERATOR WARNINGS	2
REFERENCES	3
EQUIPMENT DESCRIPTION	4
INSPECTION AND UNPACKING	4
INSTALLATION AND START-UP	5-6
OPERATION	8-9
CLEANING	10
MAINTENANCE	11
TROUBLESHOOTING	11
PARTS LIST	12-14
WATER FILL DRAIN KIT INSTALLATION INSTRUCTIONS	15
WATER FILL DRAIN KIT DIAGRAM	16
RACKS, PAN INSTALLATION INSTRUCTIONS	17
WIRING DIAGRAMS	18-19
SERVICE LOG	20
WARRANTY PROTECTION	21-22

References

UNDERWRITERS LABORATORIES, INC.
333 Pfingsten Road
Northbrook, Illinois 60062

NFPA/70 The National Electrical Code

NATIONAL SANITATION FOUNDATION
3475 Plymouth Road
Ann Arbor, Michigan 48106

NATIONAL FIRE PROTECTION ASSOCIATION
60 Batterymarch Park
Quincy, Massachusetts 02269

Website Address: www.groen.com

Equipment Description

Your Groen VRC-3E or VRC-6E Vortex Connectionless Steamer is designed to give years of service. It has a stainless steel cavity (cooking chamber) which is served by an inside water reservoir which is electrically heated. A powerful blower circulates the steam in the cavity to increase heating efficiency.

The cavity holds up to three (VRC-3E) or six (VRC-6E) steam table pans (12" x 20" x 2½" deep). An 18 gauge stainless steel case encloses the cavity and the control compartment that houses electrical components. Door hinges are reversible (the door may be set to open from the left or right). Operating Controls are on the front panel.

VRC-3E and VRC-6E steamers are equipped with fully electronic controls. These units are readily identified by their unique control panels. The On-Off switch is operated by touch pad controls.

From the rear of the VRC-3E and VRC-6E units are distinguished by the addition of a fuse box, which lets operators change fuses without removing panels.

WARNING
DISCONNECT ELECTRICAL POWER BEFORE CHANGING FUSES. FAILURE TO DO SO WILL CAUSE ELECTRICAL SHOCK OR DEATH.

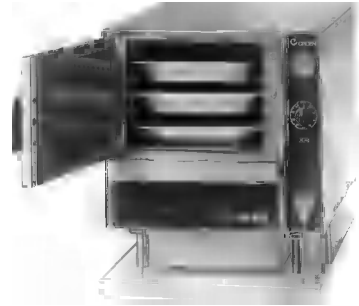

The VRC-3E holds three standard 12" x 20" x 2-½" or two 12"x20"x4" steamer pans.



The VRC-6E holds up to six standard 12"x20"x2-½" or four 12"x20"x4" steamer pans.

Inspection and Unpacking

The Steamer will be delivered completely assembled in a heavy shipping carton strapped to a skid. On receipt, inspect carton carefully for exterior damage. If damage is evident, notify the local carrier immediately and file a damage claim. Groen assumes no liability for damage incurred in transit. Reconfirm that the voltage at the location is compatible with the steamer you received.

CAUTION
SHIPPING STRAPS ARE UNDER TENSION AND CAN SNAP BACK WHEN CUT.

Carefully cut the straps and detach the sides of the carton from the skid. Pull the carton up off the unit. Be careful to avoid personal injury or equipment damage from staples which might be left in the carton walls.

CAUTION
THE VRC-3E WEIGHS 150 POUNDS (68 KG). THE VRC-6E WEIGHS 170 POUNDS (77 KG). YOU SHOULD GET HELP AS NEEDED TO LIFT THIS WEIGHT SAFELY.

Write down the model number, serial number and installation date. Keep this information for reference. Space for these entries is provided at the top of the Service Log in the back of this manual.

When starting installation, check packing materials to make sure loose parts such as the drain pan drip tray are not discarded with this material.

Installation and Start-Up

CAUTION

DO NOT INSTALL THE UNIT WITHIN 2 INCHES OF A HEAT SOURCE (SUCH AS A BRAISING PAN, DEEP FAT FRYER, CHARBROILER OR KETTLE).

Electrical Supply Connection - Observe all local, national, or other applicable codes.

Three phase models of the Vortex™ Connectionless Steamer are supplied with a cord set ready to be connected to a power supply. See the chart below for the correct matching receptacle (not supplied with the unit).

Single phase models are designed to be directly connected (hard wired) to the electrical supply and allow sufficient loop in the flexible conduit to facilitate inspection, servicing, and cleaning.

Branch Circuit Protection

Each Steamer, including individual units of stacked models, should have its own branch circuit protection and ground wire. Current and power demands for each unit are as shown below.

ELECTRICAL SUPPLY CONNECTIONS

FIELD WIRING TABLE - USE COPPER WIRE ONLY - INSULATION RATING (90°C)

VOLTAGE (60 Hz Only)	KW		RATED CURRENT DEMAND	
	VRC-3E	VRC-6E	VRC-3E	VRC-6E
208 3 PHASE	9kw	12kw	25 Amps	34 Amps
240 3 PHASE	9kw	12kw	22 Amps	29 Amps
480 3 PHASE	9kw	12kw	11 Amps	15 Amps

PLUG AND RECEPTACLE CHART

VOLTS	PHASE	PLUG		RECEPTACLE	
		9kw	12kw	9kw	12kw
208	3	15-30P	15-50P	15-30R	15-50R
240	3	15-30P	15-50P	15-30R	15-50R
480	3	L16-30P	L16-30P	L16-30R	L16-30R
208	1	----	----	----	----
240	1	----	----	----	----



WARNING

GROUNDING INSTRUCTIONS: THIS APPLIANCE MUST BE CONNECTED TO A GROUNDED METALLIC, PERMANENT WIRING SYSTEM, OR AN EQUIPMENT GROUNDING CONDUCTOR MUST BE RUN WITH THE CIRCUIT CONDUCTORS AND CONNECTED TO THE EQUIPMENT GROUNDING TERMINAL ON THE STATION.

Water Connection(s)

No water connection is needed. The water will be poured directly into the water cavity reservoir. Avoid the use of any chemically treated water specifically filtered water.

Instructions for connecting the optional auto-fill drain kit are included with the kit.

Drain Connection

The Vortex™ Connectionless Steamer should be manually drained to the bottom containment pan supplied by the factory. If the unit is connected to a drain, do not connect more than two units to one drain line or pressure from one unit will effect the second unit.

Stacking Units Instructions

Remove drain containment pan from the bottom of unit(s). Unscrew to remove adjustable legs from base of Vortex unit(s). Unfasten nuts and bolts on stand platform(s). Place Vortex unit(s) on stand platform. Align the (4) leg holes with the holes in the platform. Secure Vortex unit(s) to stand platform(s) using bolts and washers provided in step 2 as shown in detail "A" of figure 1 on page 7.

For double stack units only:

By loosening the left screw and removing the right screw provided, mount steam exhaust bracket assembly to the back panel of the top Vortex unit as shown in detail "B" of Figure 1 on page 7. Attach the steam exhaust hose from the bottom Vortex unit's steam outlet tube to the top Vortex unit's steam exhaust bracket assembly using hose clamps provided as shown in figure 2 on page 7. (Note: Steam exhaust hose may need to be cut to fit.)

Steam Vent Assembly Instructions

Remove steam diverter assembly from literature bag which can be found inside of unit. Slide loose end as shown over unit steam outlet, tighten worm gear clamp with flat head screw driver. Be sure steam outlet is pointing in the upward position. (Shown below)

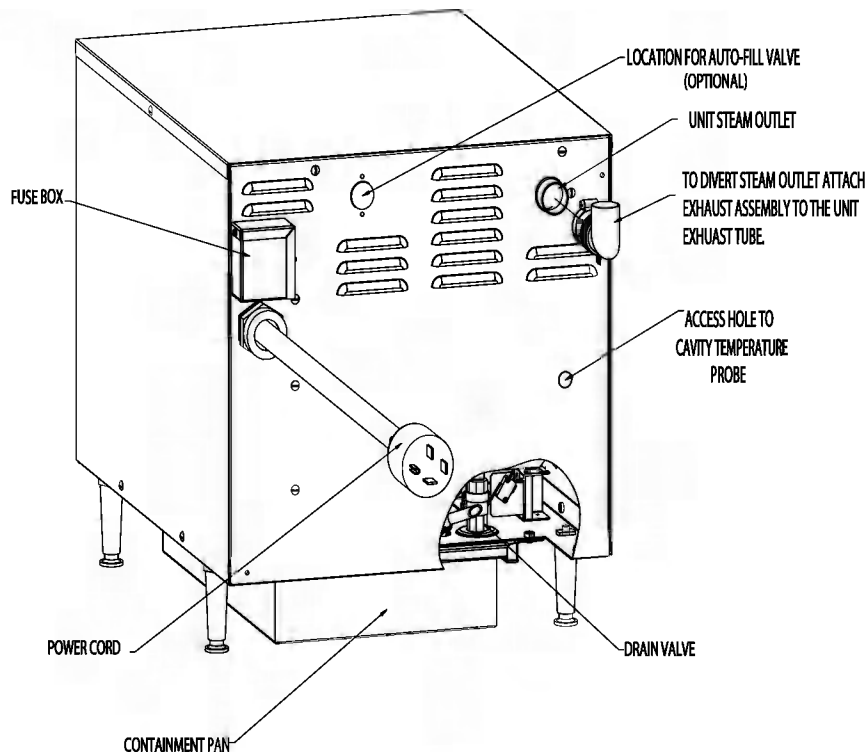

Double Stack Assembly Diagram

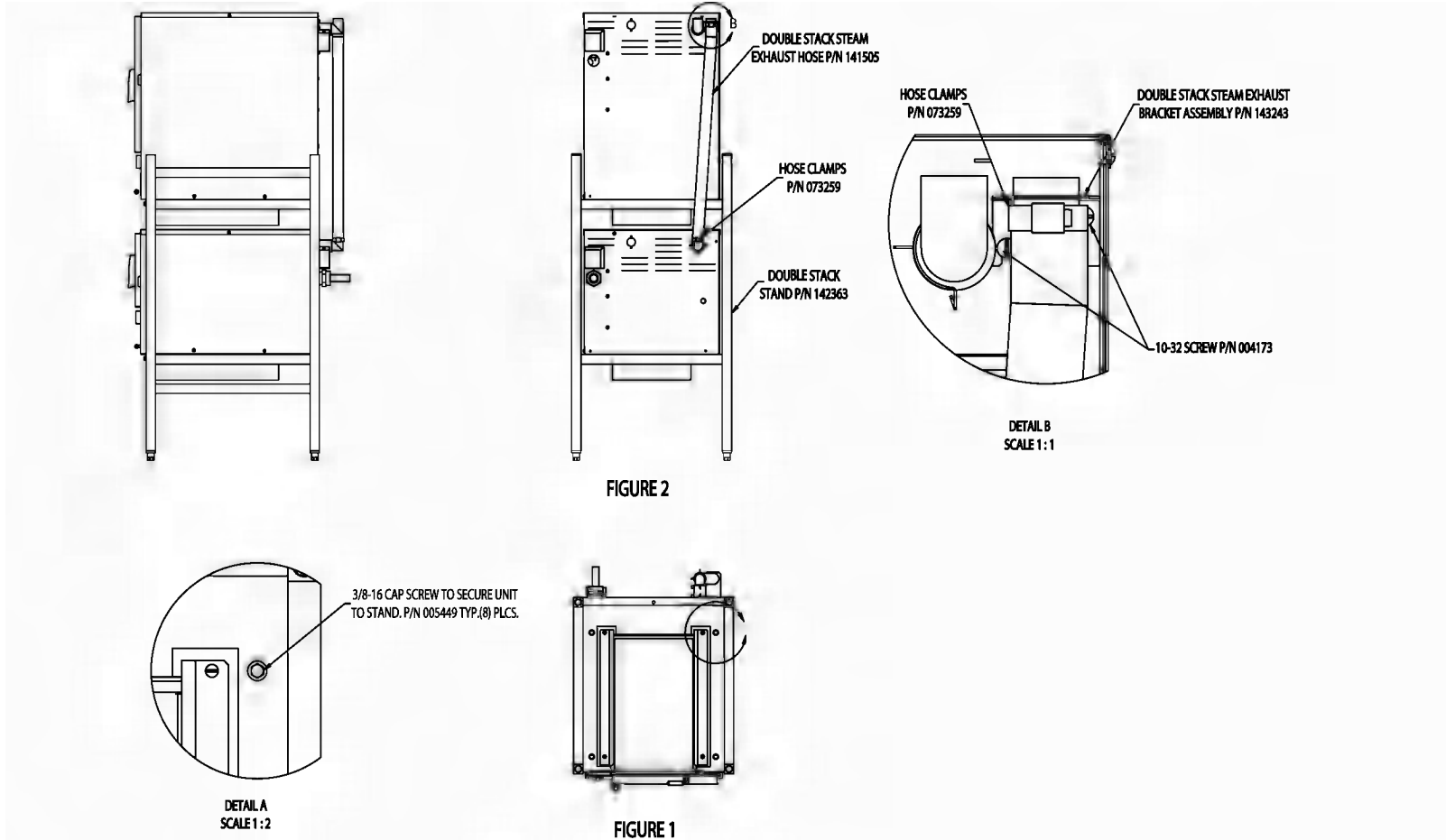

Operation

WARNING
ANY POTENTIAL USER OF THE EQUIPMENT MUST BE TRAINED IN SAFE AND CORRECT OPERATING PROCEDURES.

A. Controls

Operator controls are on the front right of the unit.

The VRC-3E and VRC-6E control panels have the following touch pads and indicator lights:

- ! The ON/OFF touch pad gets the Vortex™ ready for use, or shuts it off.
- ! The HOLD indicator light shows that the cavity is at holding temperature.
- ! The TIMING indicator light stays on when the timer is running.
- ! The ADD H2O indicator light is lit when it's time to add water.
- ! The open and closed position of the drain valve allows the unit to be filled with water or drained. This is also used to manually reset the unit.

- ! The HI TEMP indicator light comes on when the bottom of the water reservoir becomes too hot.

The unit will automatically shut off, and cannot be turned on again until the water reservoir cools down.

- ! The HI TEMP light will remain illuminated until the controls are turned on and the unit temperature is low enough to restart. Then reset the manual reset latch as indicated on the bottom label.

- ! When power has been interrupted to the Vortex or the HI TEMP light has come on, the RESET light will illuminate. The drain handle will need to be momentarily opened or closed to extinguish light.



Open/Close Handle

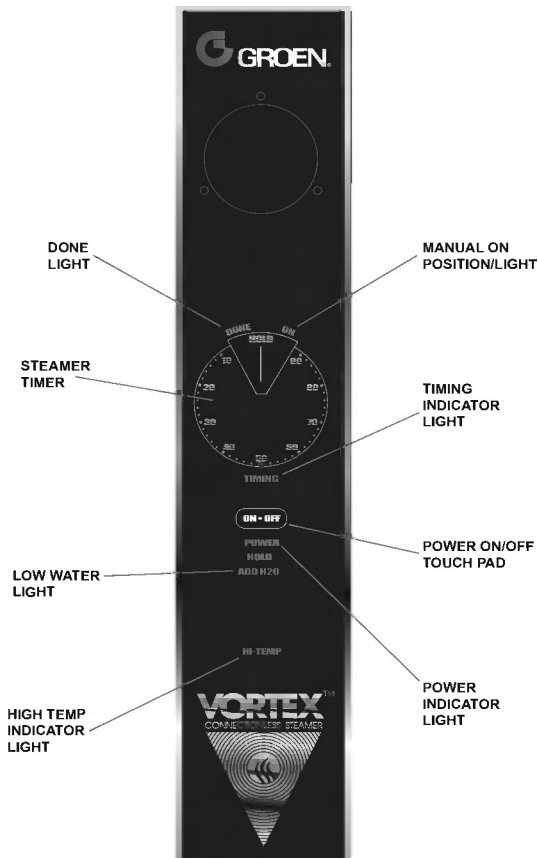

The timer is used in three ways:

- 1 In the HOLD position the steam generator stays at a low boil or “holding” temperature. Factory set at 180°F.
- 2 When a cook time is set, the timing light will illuminate. The unit steams until the timer runs down to DONE. At that time steaming stops, the DONE light illuminates and a beeper sounds.
- 3 When the timer is turned to the ON position, the unit steams continuously. The green ON light will stay illuminated.

! If you want to steam continuously, turn the timer to the manual ON position. The green ON light will illuminate. The unit will continue steaming.

! If you want to maintain food at holding temperature turn the timer to the “HOLD” position.



B. Operating Procedure

NOTE: When the unit is first installed, or anytime incoming power is interrupted, the RESET light will illuminate. Momentarily turn the drain handle to open then back to close to reset the unit and extinguish the RESET light.

1. With the cooking chamber water reservoir “empty” press the ON/OFF touch pad. The ADD H2O light will illuminate when the door is opened.. Pour water into the reservoir through the door. When the water level comes up to the hi probe the reservoir is full and 3 beeps will sound. Close door.
2. Set the timer knob to the HOLD or ON position. The unit will be ready in about 20 minutes.
3. Load food into pans in uniform layers. Pans should be filled to about the same levels, and should not be mounded.
4. Open the door and slide the pans onto the supports. If you will only be steaming one pan, put it in the middle position. Some foods will cause foam. When cooking foods that foam, such as shrimp, put an empty solid 2 ½ “ deep pan in the bottom slot of the pan racks.
5. Close the door. With the HOLD indicator illuminated, take one of the following steps:

! If you want to steam the food for a certain length of time, set the timer for that period. The timer will automatically run the steamer for the set time and then turn it off. A beeper will sound. Steam production stops. The red DONE light will illuminate.

6. To remove pans from cavity, open the door. Remove the pans from the steamer, using hot pads or oven mitts to protect your hands from the hot pans.
7. To shut off the unit, press the ON/OFF touch pad.
8. To drain the remaining water in the water reservoir, move the drain handle to the OPEN position. The drain pan will not hold all of the water in the reservoir. Allow water to cool before draining. Pull drain pan slowly from the unit to avoid sloshing.

WARNING
DO NOT EMPTY UNTIL WATER IS COOL. EMPTY DRAIN PAN. PAN WILL NOT HOLD ALL WATER FROM THE RESERVOIR. DO NOT OVER FILL DRAIN PAN.

WARNING
WHEN YOU OPEN THE DOOR, STAY AWAY FROM THE STEAM COMING OUT OF THE UNIT. THE STEAM CAN CAUSE BURNS.

Cleaning

To keep your VRC-3E or VRC-6E Connectionless Steamer in proper working condition, use the following procedure to clean the unit.

A. Suggested Tools

1. Mild detergent
2. Stainless steel exterior cleaner such as Zepper®
3. Cloth or sponge
4. Plastic wool or a brush with soft bristles
5. Spray bottle
6. Measuring cup
7. Nylon pad
8. Towels
9. Plastic disposable gloves



B. Procedure

1. Exterior Cleaning

- a. Prepare a warm solution of the mild detergent as instructed by the supplier. Wet a cloth with this solution and wring it out. Use the moist cloth to clean the outside of the unit. Do not allow freely running liquid to touch the controls, the control panel, any electrical part, or on the side or rear panels.
- b. To remove material which may be stuck to the unit, use plastic wool, a fiber brush, or a plastic or rubber scraper with a detergent solution.
- c. Stainless steel surfaces may be polished with a recognized stainless steel cleaner such as Zepper®.



2. Interior Cleaning - Clean the unit daily or as residue builds upon the bottom of the oven cavity.

- a. Press ON/OFF to turn the steamer off. Open the door..
- b. Drain the water from the unit into the drain pan and allow the unit to cool before cleaning. (Note: If the cavity is full of water, the drain pan will not hold the entire amount and must be emptied more than once.)
- c. After the unit has cooled, remove pan and pan racks from the cavity.

- d. Use a mild detergent to wipe down the steamer cavity, the probes on the inside back panel wall and the pan racks.
- e. Rinse the unit to remove detergent.
- f. Attach pan racks. Unit is ready for use.

WARNING

KEEP WATER AND CLEANING SOLUTIONS OUT OF CONTROLS AND ELECTRICAL COMPONENTS. NEVER HOSE OR STEAM CLEAN ANY PART OF THE UNIT.

EVEN WHEN THE UNIT HAS BEEN SHUT OFF, DON'T PUT HANDS OR TOOLS INTO THE COOKING CHAMBER UNTIL THE FAN HAS STOPPED TURNING.

DON'T OPERATE THE UNIT UNLESS THE REMOVABLE PARTITION HAS BEEN PUT BACK IN ITS PROPER LOCATION.

DO NOT USE ANY ACIDIC CLEANSER, DELIMER/DESCALER OR CHEMICAL PRODUCTS TO CLEAN THE UNIT.

IMPORTANT

DO NOT USE ANY METAL MATERIAL (SUCH AS METAL SPONGES) OR METAL IMPLEMENTS (SUCH AS A SPOON, SCRAPER OR WIRE BRUSH) THAT MIGHT SCRATCH ANY STAINLESS STEEL SURFACE. SCRATCHES MAKE THE SURFACE HARD TO CLEAN AND PROVIDE PLACES FOR BACTERIA TO GROW. DO NOT USE STEEL WOOL, WHICH MAY LEAVE PARTICLES IMBEDDED IN THE SURFACE WHICH COULD EVENTUALLY CAUSE CORROSION AND PITTING.

Maintenance

The VRC-3E and VRC-6E Steamers are designed for minimum maintenance, and no user adjustments should be necessary. Certain parts may need replacement after prolonged use. If there is a need for service, only authorized Groen representatives should perform the work.

If steam or condensate is seen leaking from around the door, take the following steps:

1. Check the door gasket. Replace it if it is cracked or split.
2. Inspect the cooking chamber exhaust to be sure it is not blocked.
3. Adjust the door latch pin to allow for changes that might occur as the gasket ages.
 - a. Loosen the lock nut at the base of the latch pin, then turn the latch pin ¼ turn clockwise, and tighten the lock nut.
 - b. After adjustment, run the unit to test for further steam leakage.
 - c. If there is still leakage, repeat the adjustment.
 - d. Continue adjusting the pin clockwise until the door fits tightly enough to prevent leakage.

Troubleshooting

This Groen Steamer is designed to operate smoothly and efficiently if properly maintained. However, the following is a list of checks to make in the event of a problem. Wiring diagrams are furnished inside the service panel.

SYMPTOM	WHO	WHAT TO CHECK
1. No power	User	<ol style="list-style-type: none"> a. Check wall circuit breaker. b. Disconnect power, then check fuses on back of steamer. c. Call for service technician.
2. Reset light is on	User	<ol style="list-style-type: none"> a. Momentarily turn the drain valve to open then back to closed to reset. b. Call for service technician.
3. Any unusual operation	User	<ol style="list-style-type: none"> a. Press ON/OFF pad to turn steamer off. Press again to turn steamer on. b. Call for service technician.
4. No steam	User	<ol style="list-style-type: none"> a. Check and add water as required. (For auto fill units turn unit off and on) b. Ensure door is closed. c. Call for service technician.
5. Door pops open	User	<ol style="list-style-type: none"> a. Ensure drain and vent are not plugged. No more than two units should be attached to a single drain line. b. Check door pin adjustment per above. c. Call for service technician.
6. HI TEMP Light is ON	User	<ol style="list-style-type: none"> a. Wait 30 minutes for the unit to cool down, RESET light should come on when unit has cooled. Turn unit on. Momentarily turn drain valve to reset safety circuit. b. Call for Service Technician.
7. Dial gage will not read 212	User	<ol style="list-style-type: none"> a. This may be normal, altitude and water purity may affect temperature reading on the gage.

Parts List

To order parts, contact your authorized Groen Service Agency. Supply the model designation, serial number, part description, part number, quantity, and when applicable, voltage and phase.

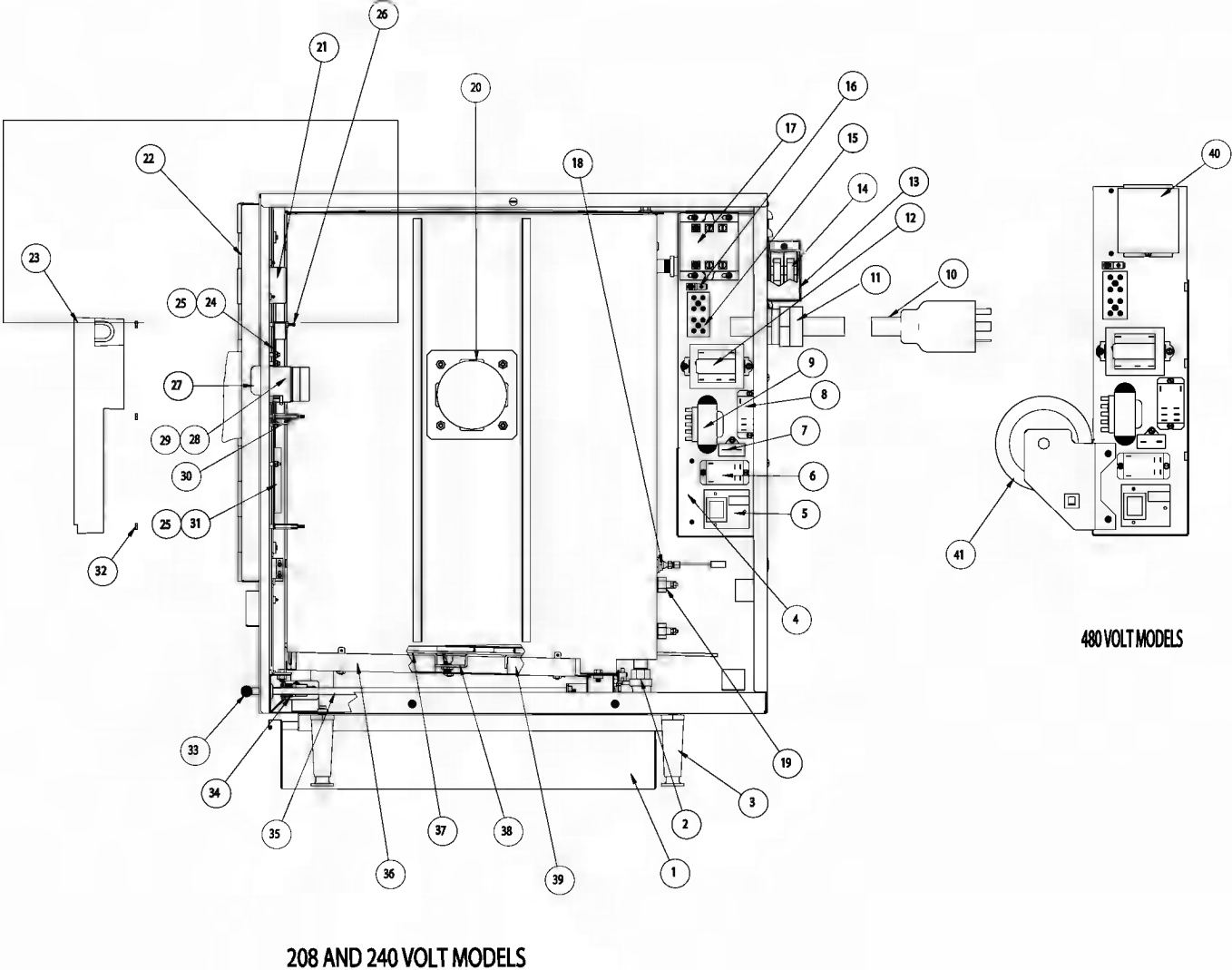

Parts List

Key	Description	Part	Key	Description	Part	Key	Description	Part
1	Drain Pan	140452	19	Water Probe	142689	39	Insulation, Heating Element	142357
2	Ball Valve, ½ N.P.T.	140534	20	Motor Assembly	096740	40	Contactactor	119811
3	Leg Appliance, 4" High	041121	21	Remote Reading Dial Thermometer	141055	41	Toroid Transformer	119856
4	Bracket, Line Connection Asm.	140457	22	Door Assembly	130858	x	Thermostat, 500 Degree Hi Limit	141661
5	Water Level Board	142533	23	Cover, Control Panel	143255	x	Grommet, 3/8 Hole, Front Panel	141670
6	Relay	119813	24	Light & Timer PC Board	137233	x	Harness, Timer Motor	123120
7	Capacitor	096813	25	Nut, Lock Nylon Insert 6-32	119855	x	Harness, Jumper, Ctr Bd to PC Bd	123122
8	Relay, Dbl Pole Dbl Throw	142542	26	Standoff, HEX. —F 6-32 x 3/4	119826	x	Harness, Jumper, Voltage Select	123124
9	Transformer	119815	27	Knob, Timer	123100	x	Harness, Control Board	125788
10	Cord Set, 30AMP 208/240V (9kw)	142339	28	Timer 60 Hz 90 Min.	141063	x	Harness, Ready Switch	119878
10	Cord Set, 50AMP 208/240V (12w)	142345						
			29	Nut, Timer Mounting	101145	x	Harness, Jumper	123125
10	Cord Set, 30AMP 480	142337	30	Standoff, HEX. —F 32 x 1-1/4	119827	x	Harness, Hold Temperature	140924
11	Strain Relief - 3 Phase only	142525	31	PC Control Board	140792	x	Blower Wheel	096790
12	Transformer, 208/240	121716	32	Nut, Keps 6-32	071289	x	Door Gasket 3E	124849
13	Fuse Box Assembly	119848	33	Handle, Shaft	141668	x	Door Gasket 6E	140748
14	Fuse 6 Amp	119823	34	Reset Light Assembly	142537	x	Reset light bulb	142547
15	Terminal Block	088214	35	Shaft, Drain Valve Actuator	141074	x	Seal, Steamer Motor	096868
16	Ground Lug	119829	36	Plate Support, Insulation	142527	x	Motor Insulator	094135
17	Contactactor	119811	37	Press Sheet, Heating Element	142509	x	Cordset, 30 AMP 3 Phase 480V	142337
18	Cavity Probe	070187	38	Holding Bracket, Heating Element	142356	x	Cordset, 30 AMP 3 Phase 240V	142339

x - Item not depicted/called out in drawing or photographs

VORTEX HEATING ELEMENTS REPLACEMENT KITS

<u>FOR 3 PAN MODELS 9KW 208V</u>	<u>Part # 143320</u>
<u>FOR 3 PAN MODELS 9KW 240V</u>	<u>Part # 143321</u>
<u>FOR 3 PAN MODELS 9KW 480V</u>	<u>Part # 143322</u>
<u>FOR 6 PAN MODELS 12KW 208V</u>	<u>Part # 143323</u>
<u>FOR 6 PAN MODELS 12KW 240V</u>	<u>Part # 143324</u>
<u>FOR 6 PAN MODELS 12KW 480V</u>	<u>Part # 143325</u>

WATER FILL-DRAIN KIT

INSTALLATION INSTRUCTIONS

1-Remove all parts from shipping cartons.

WARNING: DISCONNECT POWER BEFORE INSTALLING

2-Check-identify all parts as follow.

2.1- Water fill parts.

- 143122 BULKHEAD FITTING.....	1
- 143123 JAM NUT, 5/8-18.....	1
- 142562 TEFLON WASHER.....	1
- 142563 ELBOW, 1/8NPT TO 3/8" HOSE BARB, BRASS.....	1
- 143148 HOSE AUTO FILL LINE 3/8" ID. X 38" LONG.....	1
- 100934 WATER VALVE.....	1
- 127523 HOSE CLAMPS.....	2
- 005764 SCREW TRUSS MACHINE 8-32 THREAD.....	2

2.2- Water Drain Parts

- 142549 ELBOW 3/4 HOSE BARB 90 DEG.....	1
- 142550 TEE 3/4 HOSE BARB.....	1
- 143246 DRAIN ASSEMBLY, AUTODRAIN.....	1
- 143250 HOSE LONG 3/4"ID X 10ft	1
- 143254 HOSE 3/8" ID X 30" LONG	1

3- Water fill installation steps.

3.1 Remove left side panel from the unit.

3.2 Mark the hole center on the left side cavity wall, from the thermometer bulb hole measure 2.5" down and 9.5" from the rear of cavity as shown in the diagram.

3.2.a Cut out a 3" square of insulation around the hole center

3.3 Drill a 5/8" DIA. hole. Note; make sure to remove all burrs on both in and out side of the cavity, any burrs will cause the fitting to leak

3.3.a Install bulkhead fitting and teflon washer from the inside of the cavity, and thread jam nut from outside to hold in place and seal, refer to drawing.

3.4 Thread brass elbow into the bulkhead fitting from outside of the cavity with barb end pointing toward the back of the unit as shown on the drawing.

3.5 On the back panel of the unit, locate the 1inch diameter pre drilled hole and pop out the plug.

3.6 Install the water valve from inside of the unit with the 8-32 screws from outside thru the pre drilled holes

3.7 Connect hose auto fill line to the outlet port on the valve and to the brass elbow on the side of the unit thru the hose clamps, see drawing. Use the tension hose clamps to secure on both ends of the hose, one on the valve and the other on the brass barb. Note, if you are installing the kit in a 3pan capacity unit cut hose to fit.

3.8 Connect the two hose electrical leads to the solenoid valve. The leads are marked with WV-1 and WV-2. The wiring harness has these two leads loose inside th unit.

4- Water drain installation steps.

4.1 The condensate drain line needs to be disconnected before the left side cabinet panel can be replaced.

4.1.a From the bottom of the unit just right of the drain valve unscrew the condensate drip bracket.

4.1.b From the inside, loosen the tension clamps and remove the bracket from the hose and the hose from the condensate line.

4.1.c Slide the tension clamps off of the hose and use them on next step.

4.1.d Install one end of the supplied hose 3/8" inside diameter x 30" long on the condensate line where the condensate trap to drain hose were installed before, pull the other end of the hose through the hole where the bracket was mounted. Reinstall the inside tension clamp.

4.2 Guide the hose loose end thru the uncovered hole to the outside bottom of the unit as drawing shows.

4.3 Thread the hose drain assembly onto the unit drain valve, see drawing.

4.4 Connect the 3/8" diameter x 30" long hose loose end to the plastic barb fitting on the drain assembly and reuse the other tension hose clamps.

4.4.a If you are installing a kit on a 3 pan model cut this 3/8" x 30" long hose to fit..

4.5 A 10ft piece of hose is supplied with this kit, it can be cut to length and used with the elbow to help route the hose to the proper drain location

4.6 For single units cut the long hose to length as needed to route it to facility drain. Note hose end must have at least a 2" gap from the floor drain, do not use traps.

4.7 For double stack units, a 6.5" long piece of hose can be cut to join the upper and lower cavities by using the supplied tee on the bottom unit, the supplied elbow on the top unit and a piece to connect the two cavities as shown. Permit a 2" air gap from the floor drain. Do not use traps.

5- Test to ensure the final assembly of the drain line allows the water to flow freely.

Loops or kinks in the hose will cause back pressure which may cause the door to pop open during draining.

Water Fill Drain Kit Diagram

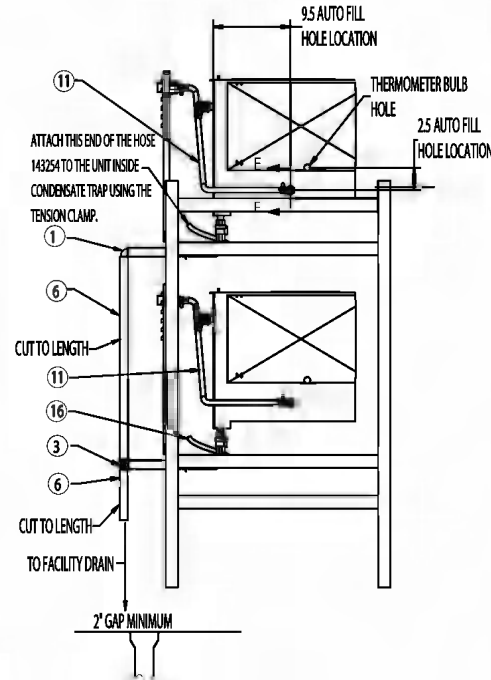
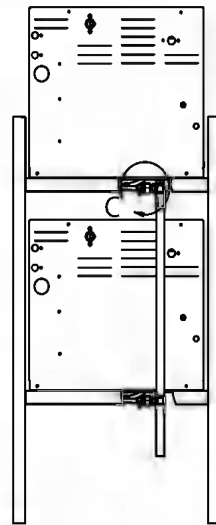
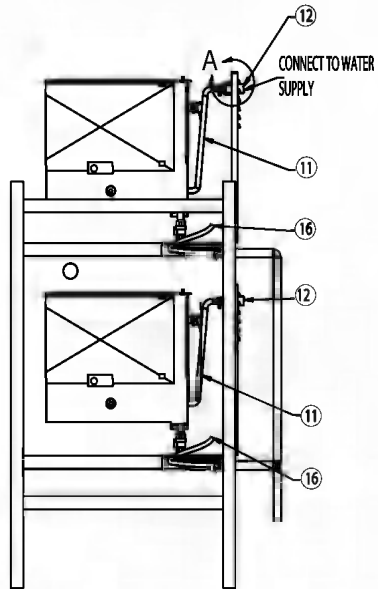
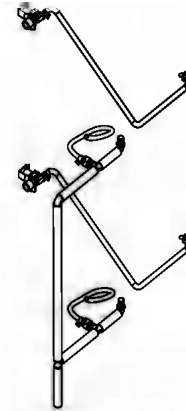
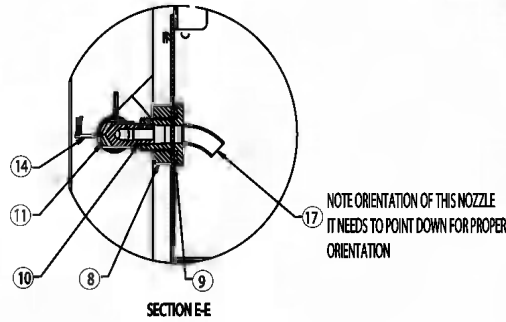
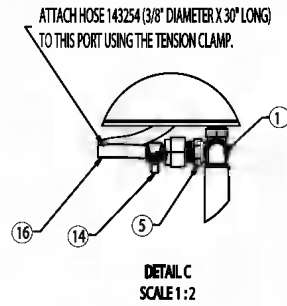
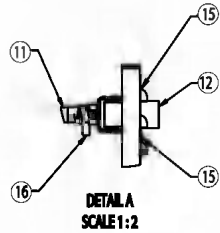

ITEM NO.	PART NO.	DESCRIPTION
17	143256	BULKHEAD FITTING ASSEMBLY
16	143254	HOSE 3/8" ID X 30' LONG
15	005764	SCREW TRUSS MACHINE 8-32 THREAD
14	127523	HOSE CLAMP
12	100894	WATER VALVE
11	143148	HOSE, AUTOFILL LINE 3/8" ID X 38" LONG
10	142563	ELBOW 1/8 NPT TO 3/8 HOSE BARB
9	142562	WASHER, TEFLON AUTOFILL-DRAIN KIT
8	143123	NUT, JAM 5/8-18
6	143250	HOSE, LONG 3/4" ID X 10 ft.
5	143246	DRAIN ASSEMBLY, AUTODRAIN KIT
4	140789	BACK PANEL, REFERENCE ONLY.
3	142550	TEE, 3/4" HOSE BARB
2	141067	CHAMBER ASSEMBLY, REFERENCE ONLY
	142549	ELBOW 3/4" HOSE BARB
ITEM NO.	PART NO.	DESCRIPTION

PAN RACKS FOR SINGLE STANDS ONLY INSTALLATION INSTRUCTIONS

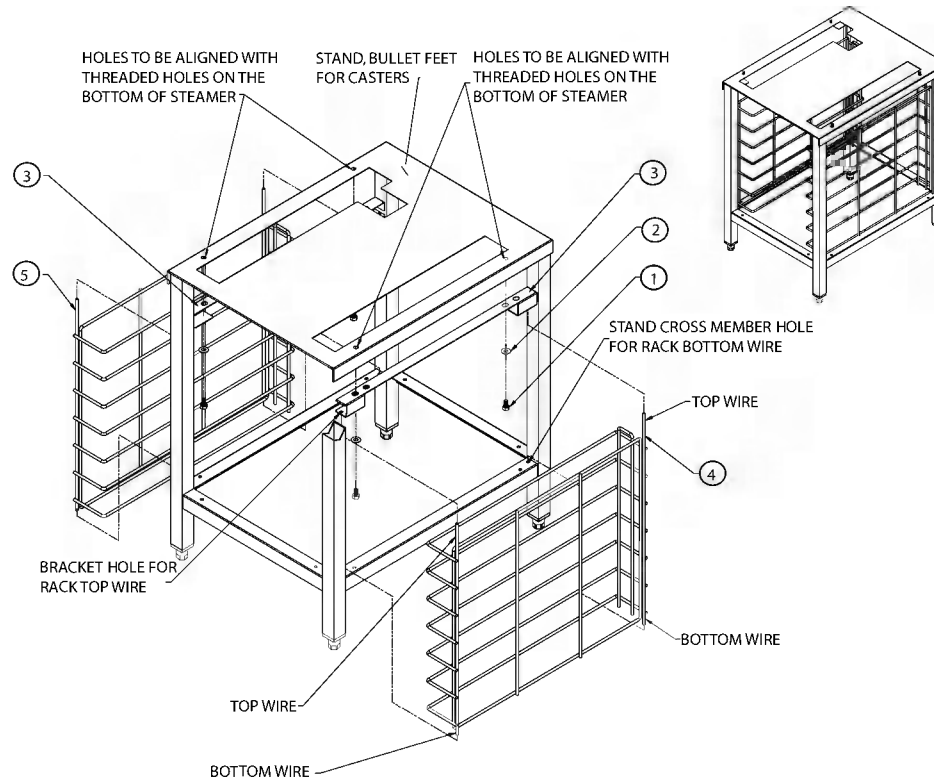

ASSEMBLY INSTRUCTIONS:

1. Unpack racks kit.
2. Identify parts.
3. Unscrew and remove screws #1 and washers #2 from the bottom of your steamer. Do not move the steamer. This will allow the bottom threaded holes to stay aligned with the holes on the stand.
4. Secure brackets #3 using screws #1 and washers #2 thru the holes on the stands and into the threaded holes on the bottom of your steamer.
5. To place racks on stand, align wires from top of the rack with the corresponding holes in bracket #3. Push the rack all the way up into the bracket. Align bottom of the rack wires with the holes in the stand leg and allow rack to fall in position.

Wiring Diagram- VRC-6E

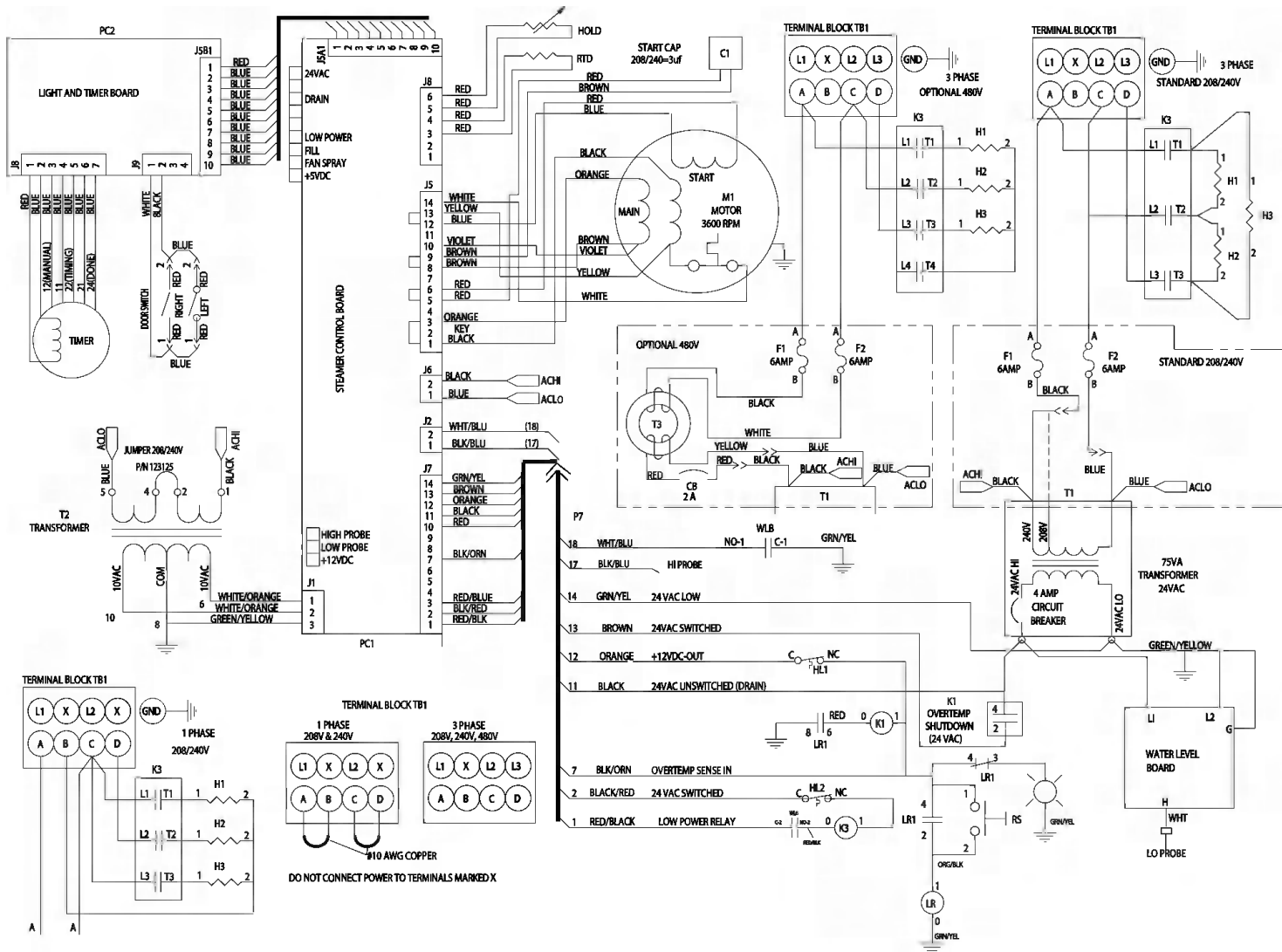

143258 Rev B

Service Log

Model No. _____ Purchased From _____
Serial No. _____ Location _____
Date Purchased _____ Date Installed _____
Purchase Order No. _____ For Service Call _____

Date	Maintenance Performed	Performed by

GROEN® LIMITED WARRANTY TO COMMERCIAL PURCHASE*

(U.S. & Canadian Sales Only)

Groen® warrants to original commercial purchaser/users that foodservice equipment manufactured by Groen® ("Groen® Equipment") other than CapKold® foodservice equipment, shall be free from defects in material and workmanship for twelve (12) months from the date of installation or fifteen (15) months from date of shipment from Groen®, whichever date first occurs (the "Warranty Period"), in accordance with the following terms and conditions:

- I.** This warranty is limited to replacement parts and related labor for Groen® Equipment located at its original place of installation in the United States and Canada.
- II.** Damage to Groen® Equipment that occurs during shipment must be reported to the carrier, and is not covered under this warranty. The reporting of any damage during shipment is the sole responsibility of the commercial purchaser/user of such Groen® Equipment.
- III.** For Groen® Convection Combo™ Steamer-Ovens, HyPerSteam™ Convection Steamers and HyPlus™ Pressureless Steamers, Groen® further warrants to the original commercial purchaser/users of such Groen® Equipment that the atmospheric steam generators or boilers contained in such Groen® Equipment shall be free from defects in material and workmanship for twenty-four (24) months from the date of installation or twenty-seven (27) months from date of shipment from Groen®, whichever date first occurs, provided that: (a) the original purchaser/user shall have also purchased and installed a Groen® PureSteam Water Treatment System™ for use in connection with such Groen® Convection Combo™ Steamer-Oven, HyPerSteam™ Convection Steamer or HyPlus™ Pressureless Steamer on or before the date such Groen® Equipment was installed, (b) the original purchaser/user has continuously used such Water Treatment System in connection with such Groen® Equipment from the date of installation, and (c) the commercial purchaser/user shall have maintained such Water Treatment System in accordance with the maintenance and filter cartridge replacement recommendations of Groen®, and otherwise maintained such Oven or Steamer in accordance with all other operational and maintenance recommendations of Groen®.
- IV.** Groen® further warrants to the original commercial purchaser/users of Groen® Convection Combo™ Steamer-Ovens that the electronic relay and control board contained in such Groen® Convection Combo™ Steamer-Oven shall be free from defects in material and workmanship for twenty-four (24) months from the date of installation or twenty-seven (27) months from date of shipment from Groen®, whichever date first occurs.
- V.** During the Warranty Period, Groen®, directly or through its authorized service representative, will either repair or replace, at Groen's sole election, any Groen® Equipment determined by Groen® to have a defect in material or workmanship. As to any such warranty service during the Warranty Period, Groen® will be responsible for related reasonable labor and portal to portal transportation expenses (time & mileage) incurred within the United States and Canada.
- VI.** This warranty does not cover boiler maintenance, calibration, periodic adjustments as specified in operating instructions or manuals, consumable parts (such as scraper blades, gaskets, packing, etc.), and labor costs incurred for removal of adjacent equipment or objects to gain access to Groen® Equipment. This warranty does not cover defects caused by improper installation, abuse, careless operation, or improper maintenance of Groen® Equipment. This warranty does not cover damage to Groen® Equipment caused by poor water quality or improper boiler maintenance.
- VII.** THIS WARRANTY IS EXCLUSIVE AND IS IN LIEU OF ALL OTHER WARRANTIES, EXPRESSED OR IMPLIED, INCLUDING ANY IMPLIED WARRANTY OF MERCHANTABILITY OR FITNESS FOR A PARTICULAR PURPOSE, EACH OF WHICH IS HEREBY EXPRESSLY DISCLAIMED. THE REMEDIES DESCRIBED ABOVE ARE EXCLUSIVE AND IN NO EVENT SHALL GROEN® BE LIABLE FOR SPECIAL, CONSEQUENTIAL, OR INCIDENTAL DAMAGES FOR THE BREACH OR DELAY IN PERFORMANCE OF THIS WARRANTY.
- VIII.** Groen® Equipment is for commercial use only. If sold as a component of another (O.E.M.) manufacturer's equipment, or if used as a consumer product, such Equipment is sold AS IS and without any warranty.

*Covers all Groen® Equipment (other than CapKold® foodservice equipment) ordered after September 11, 2001.

GROEN® LIMITED EXTENDED WARRANTY COVERAGE* **(U.S. & Canadian Sales Only)**

Limited Extended Warranty Coverage is available on all standard Groen® Equipment (other than CapKold® foodservice equipment) covered by the above Groen® Limited Warranty. Commercial purchasers/users of Groen® Equipment may elect to extend the standard limited warranty to cover parts, labor and portal to portal transportation costs (time and mileage) for an additional twelve (12) or twenty four (24) month period, in addition to the time period of the standard limited warranty described above. Limited Extended Warranty Coverage is not available to extend the supplemental limited warranty for: (a) atmospheric steam generators or boilers contained in Groen® Convection Combo™ Steamer-Ovens, HyPerSteam™ Convection Steamers and HyPlus™ Pressureless Steamers, or (b) electronic relay and control boards contained in Groen® Convection Combo™ Steamer-Ovens.

Cost of Extended Coverage

Five percent (5.0%) of the LIST PRICE of the Groen® Equipment to be covered by the Limited Extended Warranty for each additional twelve (12) months of limited extended warranty coverage. The five percent (5.0%) of the LIST PRICE charge will be the net invoice amount for each year of Limited Extended Warranty Coverage purchased.

Conditions of Coverage

- (1) Limited Extended Warranty Coverage must be purchased at the time the Groen® Equipment to be covered is purchased.
- (2) All conditions and limitations on the Standard Limited Warranty Coverage apply to the Limited Extended Warranty Coverage. See above for details of conditions and limitations on the Standard Warranty Coverage.

*Covers all Groen® Equipment (other than CapKold® foodservice equipment) ordered after September 11, 2001.



1055 Mendell Davis Drive
Jackson, MS 39272
Telephone 601 372-3903
Fax 601 373-9587

OM-VRC-3E/VRC-6E

Part Number 141762 Rev A

Revised 12/02