



MACHO NACHO™

Chip Warmer

FDW-1-MN & FST-1-MN Series

Installation & Operating Manual

I&W #07.05.087.00

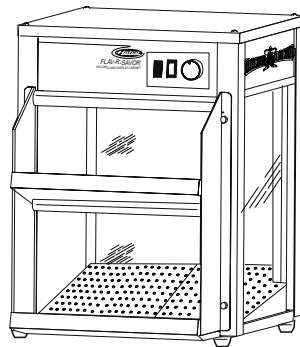

This manual contains important safety information concerning the maintenance, use and operation of this product. Failure to follow the instructions contained in this manual may result in serious injury. If you are unable to understand the contents of this manual, please bring it to the attention of your supervisor. Do not operate this equipment unless you have read and understood the contents of this manual.

Este manual contiene importante información sobre seguridad concerniente al mantenimiento, uso y operación de este producto. Cualquier falla en el seguimiento de las instrucciones contenidas en este manual puede resultar en un serio daño. Si usted no puede entender el contenido de este manual por favor pregunte a su supervisor. No opere este equipo al menos que haya leído y comprendido el contenido de este manual.

CONTENTS

| | | | |
|--|---|--|------------|
| Important Owner Information | i | Installation | 4 |
| Introduction | i | Set-Up | 4 |
| Important Safety Instructions | 1 | Operation | 5 |
| Model Description | 2 | All Models | 5 |
| All Models | 2 | Maintenance | 6 |
| FDW-1-MN Model | 2 | General | 6 |
| FST-1-MN Model..... | 2 | Cleaning | 6 |
| Specifications | 3 | Display Light Bulb Replacement..... | 6 |
| Plug Configurations | 3 | Hatco Limited Warranty | 7 |
| Electrical Rating Chart..... | 3 | Authorized Parts Distributors | Back Cover |
| Dimensions..... | 3 | | |

IMPORTANT OWNER INFORMATION

Record the model number, serial number (identification decal located on the back of the unit), voltage and purchase date of your Macho Nacho™ Chip Warmer in the spaces below. Please have this information available when calling Hatco for service assistance.

Model No. _____

Serial No. _____

Voltage _____

Date of Purchase _____

Business Hours: 8:00 a.m. to 5:00 p.m.
Central Standard Time

(Summer Hours: June to September –
8:00 a.m. to 5:00 p.m. C.D.T.
Monday through Thursday
8:00 a.m. to 2:30 p.m. C.D.T. Friday)

Telephone: (800) 558-0607; (414) 671-6350



Fax: (800) 690-2966 (Parts & Service)
(414) 671-3976 (International)

Additional information can be found by visiting our web site at www.hatcocorp.com

INTRODUCTION

The Hatco Macho Nacho™ Chip Warmer is designed to hold nacho chips for prolonged periods of time while maintaining that “just-made” quality. Hatco Chip Warmers provide the best environment for food products by regulating the air temperature. Macho Nacho models use hot air only (no moisture) that is circulated through distribution panels at the base. This prevents the loss of natural oils, eliminating the need to frequently replace stale chips.

This manual provides the installation, safety and operating instructions for the Macho Nacho Chip Warmers. We recommend all installation, operating and safety instructions appearing in this manual be read prior to installation or operation of your Hatco Macho

Nacho Chip Warmer. Safety instructions that appear in this manual after a warning symbol  and the words **WARNING** or **CAUTION** printed in bold face are very important.  **WARNING** means there is the possibility of serious injury or death to yourself or others.  **CAUTION** means there is the possibility of minor or moderate injury. **CAUTION** *without the symbol* signifies the possibility of equipment or property damage only.

Hatco Macho Nacho Chip Warmer is a product of extensive research and field testing. The materials used were selected for maximum durability, attractive appearance and optimum performance. Every unit is thoroughly inspected and tested prior to shipment.

IMPORTANT SAFETY INSTRUCTIONS

IMPORTANT! Read the following important safety instructions to avoid personal injury or death, and to avoid damage to the equipment or property.

⚠ WARNINGS

- ⚠ Plug unit into a properly grounded electrical outlet of the correct voltage, size, and plug configuration. If the plug and receptacle do not match, contact a qualified electrician to determine the proper voltage and size, and install the proper electrical outlet.
- ⚠ To avoid any injury, turn the power switch off at the fuse disconnect switch/circuit breaker or unplug the unit from the power source and allow to cool completely before performing any maintenance or cleaning.
- ⚠ For safe and proper operation, the unit must be located at a reasonable distance from combustible walls and materials. If safe distances are not maintained, discoloration or combustion could occur.
- ⚠ Only light bulbs which meet or exceed N.S.F. standards, specifically designed for food holding areas must be used. Breakage of light bulbs not specially coated could result in personal injury and/or food contamination.
- ⚠ To prevent any injury, discontinue use if power cord is frayed or worn.
- ⚠ If service is required on this unit, contact your Authorized Hatco Service Agent, or contact the Hatco Service Department at 800-558-0607 or 414-671-6350; fax 800-690-2966 or International fax 414-671-3976.
- ⚠ This product has no “user” serviceable parts. To avoid damage to the unit or injury to personnel, use only Authorized Hatco Service Agents and Genuine Hatco Parts when service is required.
- ⚠ Genuine Hatco Replacement Parts are specified to operate safely in the environments in which they are used. Some aftermarket or generic replacement parts do not have the characteristics that will allow them to operate safely in Hatco equipment. It is essential to use Hatco Replacement Parts when repairing Hatco equipment. Failure to use Hatco Replacement Parts may subject operators of the equipment to hazardous electrical voltage, resulting in electrical shock or burn.

⚠ CAUTIONS

- ⚠ Locate the unit at the proper counter height, in an area that is convenient for use. The location should be level to prevent the unit or its contents from accidentally falling, and strong enough to support the weight of the unit and food displayed.
- ⚠ Some exterior surfaces on the unit will get hot. Use caution when touching these areas to avoid injury.
- ⚠ Unit is not weatherproof. For safe and proper operation locate the unit indoors where the ambient air temperature is a minimum of 70°F (21°C).
- ⚠ To prevent injury or damage the unit must be transported in the upright position. If laid on its side, all glass surfaces must be secured with tape.

CAUTIONS

Use only non-abrasive cleaners. Abrasive cleaners could scratch the finish of your unit marring its appearance and making it susceptible to soil accumulation.

MODEL DESCRIPTION

ALL MODELS

The Hatco Macho Nacho™ Chip Warmer is a high-visibility merchandiser for warming and displaying nacho chips. The unique air flow forces warm air to the bottom and is distributed into the cabinet through holes in the floor panels directing maximum heat to the chips being served. Air is circulated to prevent the loss of natural oils, eliminating the need to frequently replace stale chips.

Macho Nacho two-door access permits easy loading and serving. Chips flow to the front of the cabinet when loading through the upper door and heated, slanted floor panel slides the hot chips back to the lower door for serving.

The user-friendly control panel makes it easy to operate and only minimum maintenance is required. The chip slide and floor panels are removable for ease of cleaning.

FDW-1-MN MODEL

The FDW-1-MN Model is built of stainless steel with tempered glass sides and doors. The unit holds up to 25 lbs. (11 kg) of chips.

FST-1-MN MODEL

The FST-1-MN Model is built of stainless steel and aluminum with tempered glass sides and doors. An anodized bronze exterior is standard. The unit holds up to 40 lbs. (18 kg) of chips.



Figure 1. FDW-1-MN Macho Nacho Chip Warmer

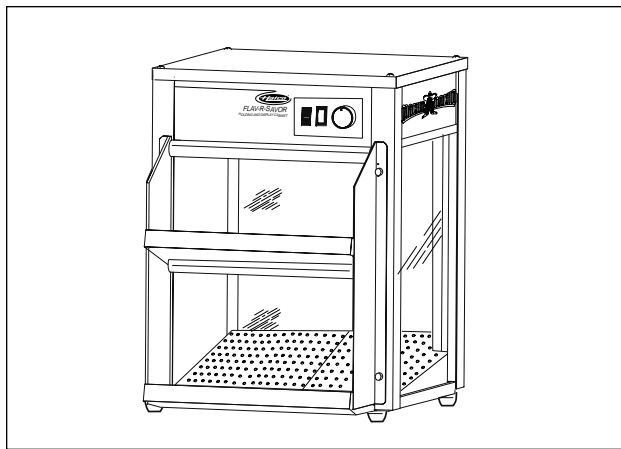

Figure 2. FST-1-MN Macho Nacho Chip Warmer

SPECIFICATIONS

PLUG CONFIGURATIONS

Units are supplied from the factory with an electrical cord and plug installed. Plugs are supplied according to the applications as shown in Figure 3.

⚠ WARNING

Plug unit into a properly grounded electrical outlet of the correct voltage, size and plug configuration. If the plug and receptacle do not match, contact a qualified electrician to determine the proper voltage and size and install the proper electrical outlet.

⚠ WARNING

To prevent any injury, discontinue use if power cord is frayed or worn.

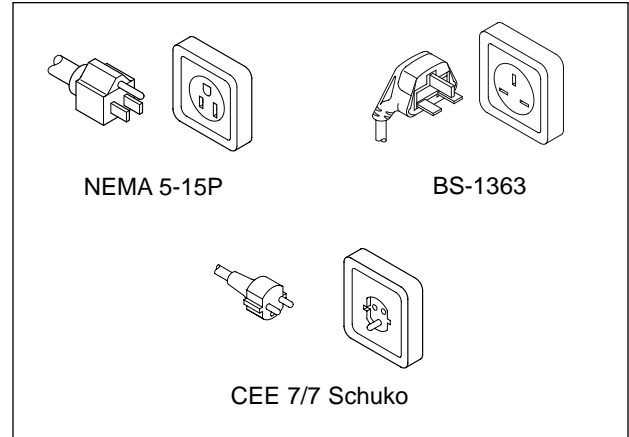

Figure 3. Plug Configurations

ELECTRICAL RATING CHART

| Model | Voltage | Hertz | Watts | Amps | Plug Configuration | Shipping Weight |
|----------|--------------|-------|-----------|---------|--------------------|------------------|
| FDW-1-MN | 100 | 60 | 1110 | 11.1 | NEMA 5-15P | 80 lbs. (36 kg) |
| | 120 | 60 | 1128 | 9.4 | NEMA 5-15P | 80 lbs. (36 kg) |
| | 220 | 50/60 | 1118 | 5.1 | CEE 7/7 Schuko | 80 lbs. (36 kg) |
| | 240 | 50/60 | 1128 | 4.7 | BS-1363 | 80 lbs. (36 kg) |
| | 220-230 (CE) | 50/60 | 1118-1222 | 5.1-5.3 | CEE 7/7 Schuko | 80 lbs. (36 kg) |
| | 230-240 (CE) | 50/60 | 1036-1128 | 4.5-5.7 | BS-1363 | 80 lbs. (36 kg) |
| FST-1-MN | 120 | 60 | 1245 | 10.4 | NEMA 5-15P | 132 lbs. (60 kg) |
| | 220 | 50/60 | 1225 | 5.6 | CEE 7/7 Schuko | 132 lbs. (60 kg) |
| | 240 | 50/60 | 1245 | 5.2 | BS-1363 | 132 lbs. (60 kg) |
| | 220-230 (CE) | 50/60 | 1219-1332 | 5.6-5.8 | CEE 7/7 Schuko | 132 lbs. (60 kg) |
| | 230-240 (CE) | 50/60 | 1150-1252 | 5.0-5.2 | BS-1363 | 132 lbs. (60 kg) |

DIMENSIONS

| Model | Width (A) | Depth (B) | Height (C) |
|----------|--------------------|--------------------|--------------------|
| FDW-1-MN | 18" (46 cm) | 22-3/8" (57 cm) | 27-1/2" (70 cm) |
| FST-1-MN | 22-7/8" (58 cm) | 27" (69 cm) | 32-5/8" (83 cm) |

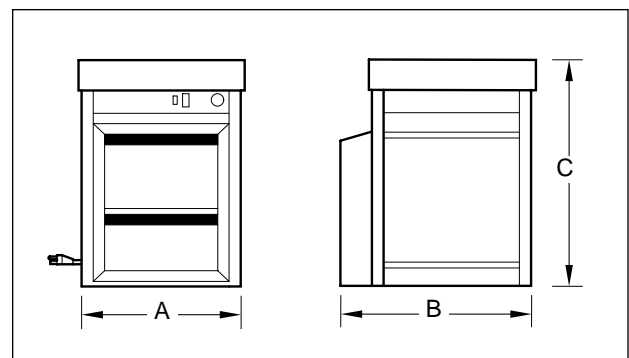

Figure 4. Dimensions

INSTALLATION

SET-UP

The Macho Nacho™ unit comes pre-assembled and ready for set-up.

1. Remove tape and protective film from all surfaces of unit.
2. Install the chip deflector inside, behind the upper door. See Figure 5.
3. Install decals on the upper front and side stainless steel panels.

Before installing decals, clean the stainless steel side panels with a non-oily cleaner, such as isopropyl alcohol (rubbing alcohol). After the cleaned surfaces have dried, simply remove the protective backing from the decal and apply to the panel. Any air pockets or bubbles behind the decal can be removed by rubbing gently with a soft cloth, working from the center of the decal towards the outer edges.

⚠ WARNING

For safe and proper operation, the unit must be located at a reasonable distance from combustible walls and materials. If safe distances are not maintained, discoloration or combustion could occur.

⚠ CAUTION

To prevent injury or damage the unit must be transported in the upright position. If laid on its side, all glass surfaces must be secured with tape.

⚠ CAUTION

Locate the unit at the proper counter height, in an area that is convenient for use. The location should be level to prevent the unit or its contents from accidentally falling, and strong enough to support the weight of the unit and food displayed.

⚠ CAUTION

Unit is not weatherproof. For safe and proper operation locate the unit indoors where the ambient air temperature is a minimum of 70°F (21°C).

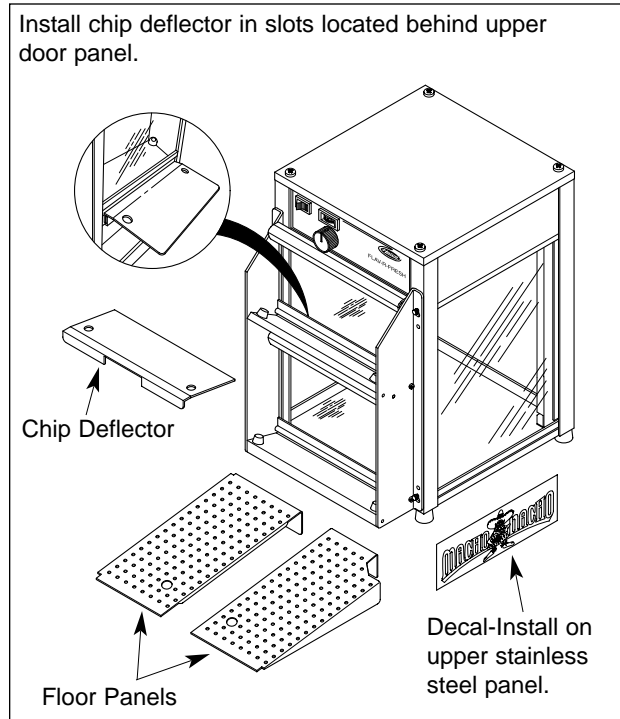

Figure 5. Set-Up (FDW-1-MN shown)

ALL MODELS

⚠ CAUTION

Some exterior surfaces on the unit will get hot. Use caution when touching these areas to avoid injury.

1. Plug warmer into a properly grounded electrical outlet of the correct voltage, size and plug configuration. See SPECIFICATIONS for details.
2. Turn the Power Switch to the ON position. See Figures 6 & 7.
3. Turn the Temperature Control to the desired temperature setting.
4. Allow unit 15-20 minutes to reach operating temperature.
5. Open top door and fill unit with chips.
6. At the end of the day or shift, turn unit off and allow to cool down. Clean as required.

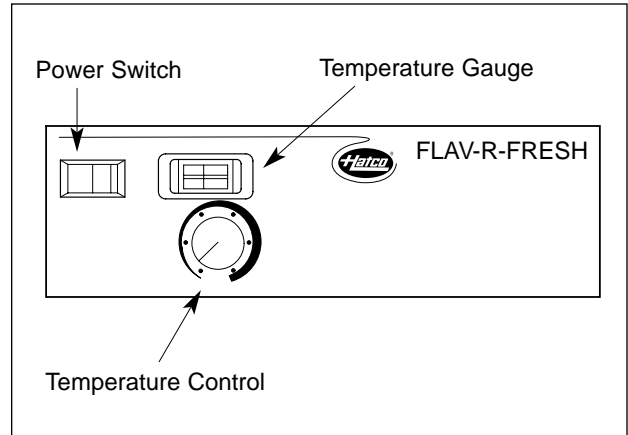

Figure 6. Control Panel FDW-1-MN

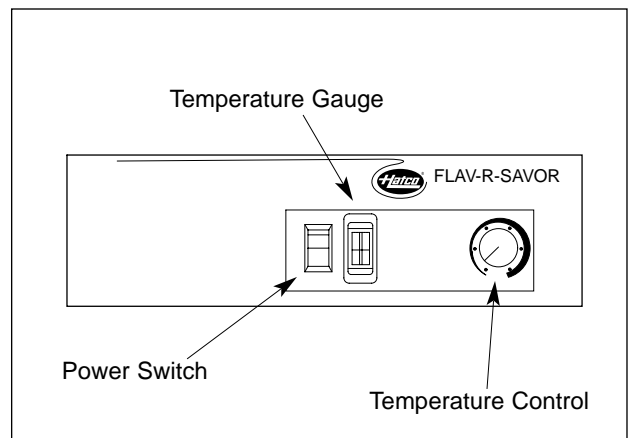

Figure 7. Control Panel FST-1-MN

MAINTENANCE

GENERAL

Hatco Macho Nacho™ Chip Warmers are designed for maximum durability and performance, with minimum maintenance.

⚠ WARNING

To avoid any injury, turn the power switch off at the fuse disconnect switch/circuit breaker or unplug the unit from the power source and allow to cool completely before performing any maintenance or cleaning.

CLEANING

To preserve the bright finish of the unit, it is recommended that the exterior and interior metal surfaces be wiped daily with a damp cloth. Stubborn stains may be removed with a good stainless steel cleaner or a non-abrasive cleaner.

CAUTION

Use only non-abrasive cleaners. Abrasive cleaners could scratch the finish of your unit marring its appearance and making it susceptible to soil accumulation.

Clean the glass using a common glass cleaner.

NOTE: For better access to the inside of the unit, the rear door panel assembly can be removed by loosening the thumbscrews on each side of the door panel assembly and lifting the assembly up and off. Be sure to tighten thumbscrews securely when installing the door panel assembly. See Figure 8.

DISPLAY LIGHT BULB REPLACEMENT

The display light is an incandescent light bulb which illuminates the warming area. The bulb has a special coating to guard against injury and food contamination in the event of breakage.

1. To replace a light bulb, disconnect the power supply and wait until the unit has cooled.
2. Bulbs have a threaded base. Unscrew the light bulb from the unit and replace it with a new specially coated incandescent bulb.

NOTE: Hatco shatter-resistant light bulbs meet N.S.F. standards for food holding and display areas. For 100 and 120 volt applications, use Hatco part #02.30.043.00. For 220 or 240 volt applications, use Hatco part #02.30.058.00.

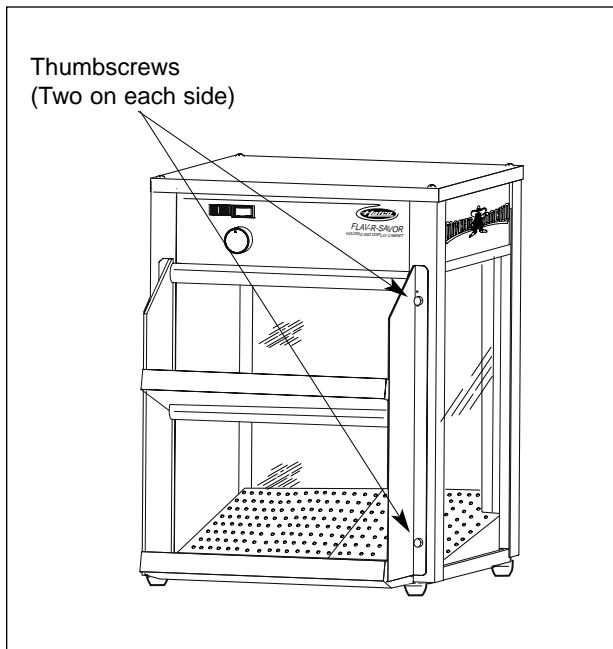

Figure 8. Removing Door Panel Assembly

⚠ WARNING

Only light bulbs which meet or exceed N.S.F. standards, specifically designed for food holding areas must be used. Breakage of light bulbs not specially coated could result in personal injury and/or food contamination.

⚠ WARNING

If service is required on this unit, contact your Authorized Hatco Service Agent, or contact the Hatco Service Department at 800-558-0607 or 414-671-6350; fax 800-690-2966 or International fax 414-671-3976.

⚠ WARNING

This product has no “user” serviceable parts. To avoid damage to the unit or injury to personnel, use only Authorized Hatco Service Agents and Genuine Hatco Parts when service is required.

⚠ WARNING

Genuine Hatco Replacement Parts are specified to operate safely in the environments in which they are used. Some aftermarket or generic replacement parts do not have the characteristics that will allow them to operate safely in Hatco equipment. It is essential to use Hatco Replacement Parts when repairing Hatco equipment. Failure to use Hatco Replacement Parts may subject operators of the equipment to hazardous electrical voltage, resulting in electrical shock or burn.

HATCO LIMITED WARRANTY

1. PRODUCT WARRANTY

Hatco warrants the products that it manufactures (the "Products") to be free from defects in materials and workmanship, under normal use and service, for a period of one (1) year from the date of purchase when installed and maintained in accordance with Hatco's written instructions or 18 months from the date of shipment from Hatco. Buyer must establish the product's purchase date by returning Hatco's Warranty Registration Card or by other means satisfactory to Hatco in its sole discretion.

Hatco warrants the following Product components to be free from defects in materials and workmanship from the date of purchase (subject to the foregoing conditions) for the period(s) of time and on the conditions listed below:

- a) **One (1) Year Parts and Labor PLUS One (1) Additional Year Parts-Only Warranty:**
 - Toaster Elements (metal sheathed)
 - Drawer Warmer Elements (metal sheathed)
 - Drawer Warmer Drawer Rollers and Slides
 - Food Warmer Elements (metal sheathed)
 - Infra-Black® Elements (metal sheathed)
 - Display Warmer Elements (metal sheathed air heating)
 - Holding Cabinet Elements (metal sheathed air heating)
 - Cook and Hold Oven Elements (metal sheathed)

- b) **One (1) Year Parts and Labor PLUS Four (4) Additional Years Parts-Only Warranty on pro-rated terms that Hatco will explain at Buyer's Request:**
 - Powermite® Gas Booster Heater Tanks
 - Mini Compact Tanks (stainless steel)
 - 3CS and FR Tanks

- c) **One (1) Year Parts and Labor PLUS Four (4) Additional Years Parts-Only Warranty PLUS Five (5) Year Parts-Only Warranty on pro-rated terms that Hatco will explain at Buyer's Request:**
 - Booster Heater Tanks (Castone®)

- d) **One (1) Year Parts-Only Warranty for components not installed by Hatco:**
 - Accessory Components (including but not limited to valves, gauges and remote switches)

THE FOREGOING WARRANTIES ARE EXCLUSIVE AND IN LIEU OF ANY OTHER WARRANTY, EXPRESSED OR IMPLIED, INCLUDING BUT NOT LIMITED TO ANY IMPLIED WARRANTY OF MERCHANTABILITY OR FITNESS FOR A PARTICULAR PURPOSE OR PATENT OR OTHER INTELLECTUAL PROPERTY RIGHT INFRINGEMENT. Without limiting the generality of the foregoing, SUCH WARRANTIES DO NOT COVER: Coated incandescent light bulbs, fluorescent lamps, lamp warmer heat bulbs, glass components or Product failure in booster tank and fin tube heat exchanger caused by liming, sediment buildup, chemical attack or freezing in tanks, Product misuse, tampering or misapplication, improper installation, application of improper voltage, or recalibration of thermostats or high limit switches.

2. LIMITATION OF REMEDIES AND DAMAGES

Hatco's liability and Buyer's exclusive remedy hereunder will be limited solely, at Hatco's option, to repair or replacement by a Hatco-authorized service agency (other than where Buyer is located outside of the United States or Canada, in which case Hatco's liability and Buyer's exclusive remedy hereunder will be limited solely to replacement of part under warranty) with respect to any claim made within the applicable warranty period referred to above. Without limiting the generality of the foregoing, all portable Products (as defined in N.S.F. 4-4.28.4) shall be delivered by Buyer, at its sole expense, to the nearest Hatco-authorized service agency for replacement or repair. Hatco reserves the right to accept or reject any such claim in whole or in part. Hatco will not accept the return of any Product without prior written approval from Hatco, and all such approved returns shall be made at Buyer's sole expense. HATCO WILL NOT BE LIABLE, UNDER ANY CIRCUMSTANCES, FOR CONSEQUENTIAL OR INCIDENTAL DAMAGES, INCLUDING BUT NOT LIMITED TO LABOR COSTS OR LOST PROFITS RESULTING FROM THE USE OF OR INABILITY TO USE THE PRODUCTS OR FROM THE PRODUCTS BEING INCORPORATED IN OR BECOMING A COMPONENT OF ANY OTHER PRODUCT OR GOODS.

HATCO AUTHORIZED PARTS DISTRIBUTORS

ALABAMA

Jones McLeod Appl. Svc.
Birmingham 205-251-0159

ARIZONA

Auth. Comm. Food Equip.
Phoenix 602-234-2443
Byassee Equipment Co.
Phoenix 602-252-0402

CALIFORNIA

Industrial Electric
Huntington Beach 714-379-7100
Chapman Appl. Service
San Diego 619-298-7106
P & D Appliance
S. San Francisco 650-635-1900

COLORADO

Hawkins Commercial Appliance
Englewood 303-781-5548

DELAWARE

Food Equipment Service
Wilmington 302-996-9363

FLORIDA

Whaley Foodservice Repair
Jacksonville 904-725-7800
Nass Service Co., Inc.
Orlando 407-425-2681
B.G.S.I.
Pompano Beach 954-971-0456
Comm. Appliance Service
Tampa 813-663-0313

GEORGIA

Southeastern Rest. Svc.
Norcross 770-446-6177

HAWAII

Burney's Comm. Service, Inc.
Honolulu 808-848-1466
Food Equip Parts & Service
Honolulu 808-847-4871

ILLINOIS

Parts Town
Lombard 708-865-7278
Eichenauer Elec. Service
Decatur 217-429-4229
Midwest Elec. Appl. Service
Elmhurst 630-279-8000
Cone's Repair Service
Moline 309-797-5323

INDIANA

GCS Service
Indianapolis 317-545-9655

IOWA

Electric Motor Service Co.
Davenport 319-323-1823

KENTUCKY

GCS Service
Louisville 502-367-1788

LOUISIANA

Chandlers Parts & Service
Baton Rouge 225-272-6620
Bana Comm. Parts, Inc.
Shreveport 318-631-6550

MARYLAND

Electric Motor Service
Baltimore 410-467-8080
GCS Service
Silver Spring 301-585-7550

MASSACHUSETTS

Ace Service Co., Inc.
Needham 781-449-4220

MICHIGAN

Commercial Kitchen Service
Bay City 517-893-4561
Bildons Appliance Service
Detroit 248-478-3320

Midwest Food Equip. Service
Grandville 616-261-2000

MINNESOTA

GCS Service
Minneapolis 612-546-4221

MISSOURI

GCS Service
Kansas City 816-920-5999
Commercial Kitchen Services
St. Louis 314-890-0700

Kaemmerlen Parts & Service
St. Louis 314-535-2222

NEBRASKA

Anderson Electric
Omaha 402-341-1414

NEVADA

Burney's Commercial
Las Vegas 702-736-0006
Hi. Tech Commercial Service
N. Las Vegas 702-649-4616

NEW JERSEY

Jay Hill Repair
Fairfield 973-575-9145
Service Plus
Flanders 973-691-6300

NEW YORK

Acme American Repairs, Inc.
Brooklyn 718-456-6544
Alpro Service Co.
Brooklyn 718-386-2515

NEW YORK (continued)

Appliance Installation
Buffalo 716-884-7425
Northern Parts Dist.
Plattsburgh 518-563-3200
J. B. Brady, Inc.
Syracuse 315-422-9271

NORTH CAROLINA

Authorized Appliance
Charlotte 704-377-4501

OHIO

Akron/Canton Comm. Svc. Inc.
Akron 330-753-6635
Certified Service Center
Cincinnati 513-772-6600

GCS Service
Columbus 614-476-3225

Electrical Appl. Repair Service
Independence 216-459-8700

E. A. Wichman Co.
Toledo 419-385-9121

OKLAHOMA

Hagar Rest. Service, Inc.
Oklahoma City 405-235-2184
Krueger, Inc.
Oklahoma City 405-528-8883

OREGON

Bressie Electric Co.
Portland 503-231-7171

Ron's Service, Inc.
Portland 503-624-0890

PENNSYLVANIA

Authorized Factory Service
Coraopolis 412-262-2330
FAST Comm. Appl. Service
Philadelphia 215-288-4800

GCS Service
Pittsburgh 412-787-1970

K & D Service Co.
Harrisburg 717-236-9039

Elmer Schultz Services
Philadelphia 215-627-5401

Electric Repair Co.
Reading 610-376-5444

RHODE ISLAND

Marshall Electric Co.
Providence 401-331-1163

SOUTH CAROLINA

Whaley Foodservice Repair
W. Columbia 803-791-4420

TENNESSEE

Camp Electric
Memphis 901-527-7543

TEXAS

Stove Parts Supply
Fort Worth 817-831-0381

Armstrong Repair Service
Houston 713-666-7100

Commercial Kitchen Repair Co.
San Antonio 210-735-2811

San Antonio Rest. Equip.
San Antonio 210-532-1660

UTAH

GCS Service
Salt Lake City 801-487-3653

VIRGINIA

Daubers
Norfolk 757-855-4097

Daubers
Springfield 703-866-3600

WASHINGTON

Restaurant Appl. Service
Seattle 206-524-8200

WISCONSIN

A.S.C., Inc.
Madison 608-246-3160

A.S.C., Inc.
Milwaukee 414-543-6460

CANADA

BRITISH COLUMBIA

Key Food Equipment Service
Vancouver 604-433-4484

ONTARIO

R.G. Henderson Ltd.
Toronto 416-422-5580

Choquette CKS
Ottawa 613-739-8458

QUÉBEC

Choquette CKS
Montreal 514-722-2000

Choquette CKS
Québec City 418-681-3944

HATCO CORPORATION

P.O. Box 340500, Milwaukee, WI 53234-0500 U.S.A.

(800) 558-0607 (414) 671-6350

Parts & Service Fax (800) 690-2966 Int'l. Fax (414) 671-3976

www.hatcocorp.com