



IMPORTANT NOTE:

Locate the Specification Label on unit to determine exact Model Name and electrical specifications. This information is needed to identify the correct replacement parts. See exploded view illustration(s) for Specification Label location.



Use of replacement parts other than those supplied by Hatco Corporation may result in damage to unit or injury to personnel and will void all warranties.

Glo-Ray® Infrared Strip Heaters

GRA, GRAH, GRAL, and GRAHL Series

<u>Model Name</u>	<u>Page</u>	<u>Model Name</u>	<u>Page</u>
All Models	2	Options and Accessories	6
Heating Elements.....	4-5		

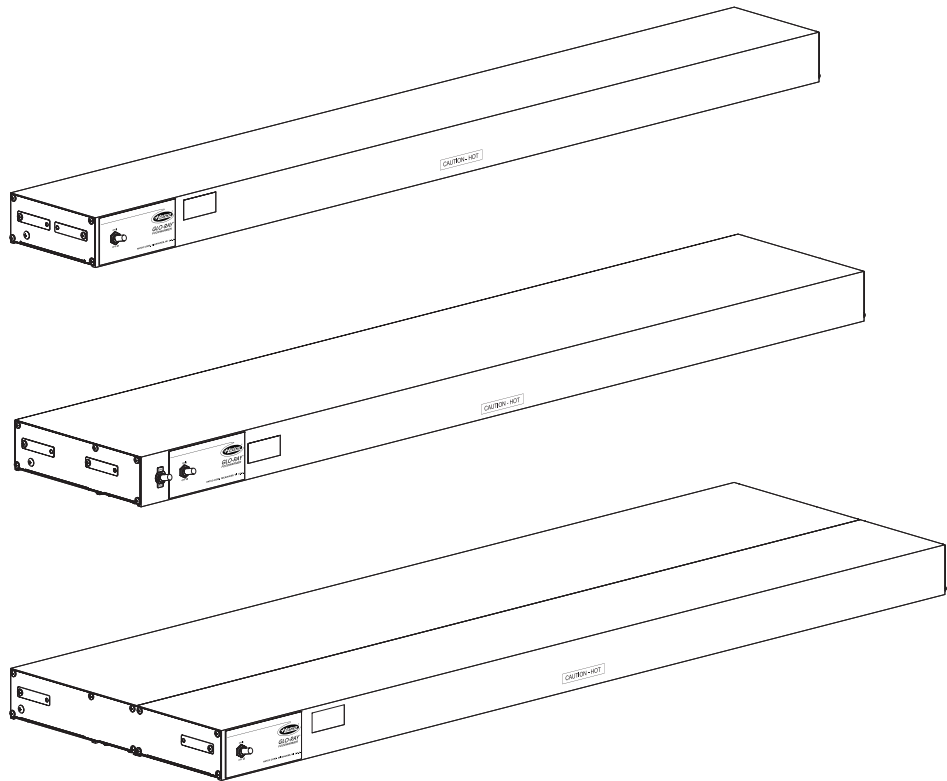

Replacement Parts List

Glo-Ray® Strip Heaters
GRA, GRAH, GRAL, and GRAHL Series

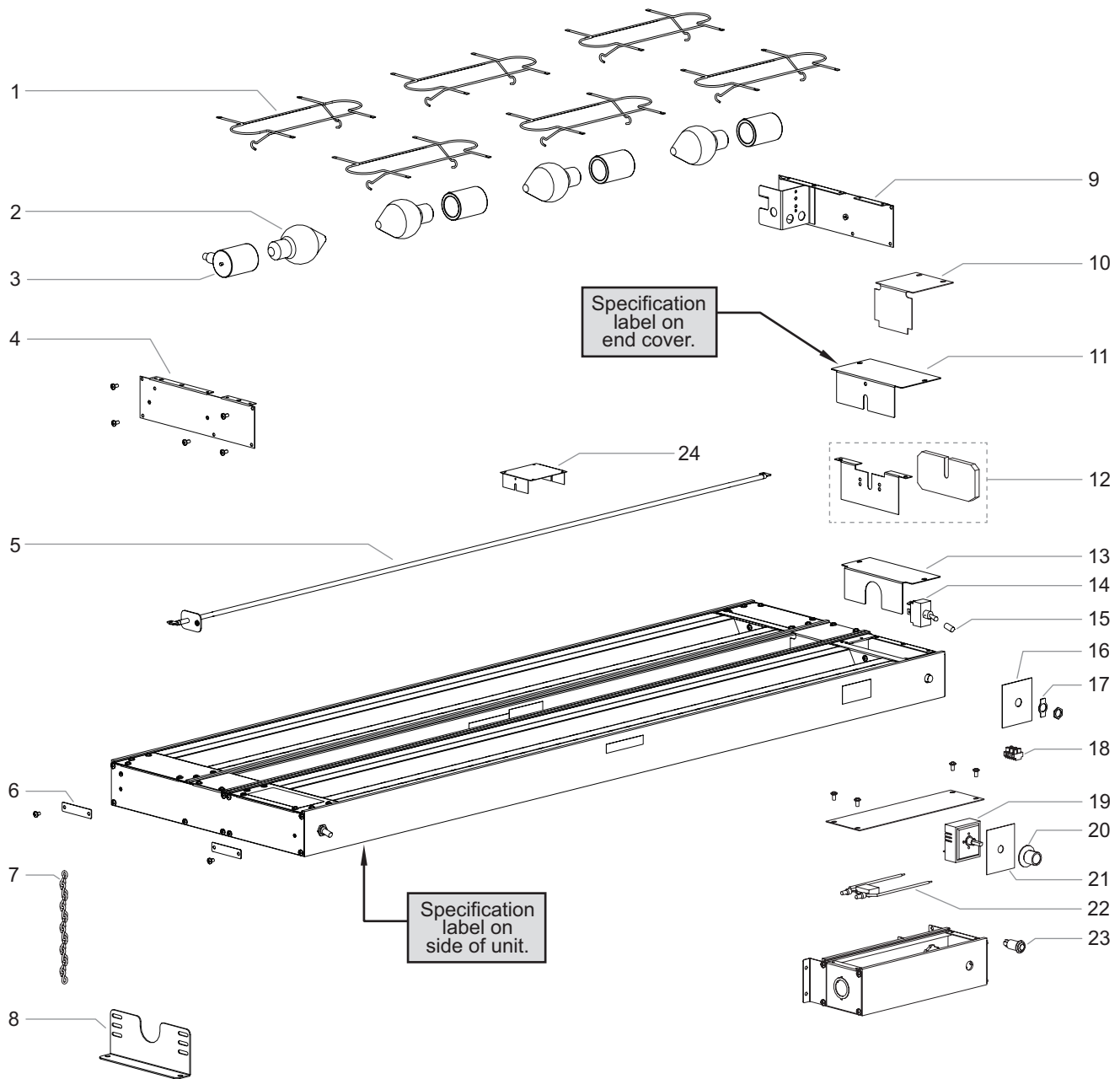

NOTE: Custom units may not be included in this parts list.

NOTE: The last four digits in a ten digit numerical serial number are the manufacturing date code.

Example: Serial number 9625061331 has a date code of "1331" which indicates the following: 1331

└─ Week Thirty-One
└─ Year 2013

Parts for Glo-Ray Strip Heaters

Item	Description	Part No.	Qty.
1	Wire Guard See "Wire Guards" Table below		1-20
2	Light Bulb, Coated, 60 Watt		
	100, 120 V	02.30.043.00	1
	220, 240, 220-230, 230-240 V	02.30.058.00	1
3	Light Socket		
	Single, Standard Watt	02.30.044.00	1
	Single, High Watt	02.30.051.00	1
	Dual	02.30.045.00	1
4	End Plate, Right Side		
	6"	04.09.051.00	1
	9"	04.09.114.00	1
	15"	04.10.018.00	1
	18"	04.15.299.00	1
5	Heating Elements	See Pages 4 & 5	
6	Hanger Tab	04.08.042.00	4
7	Chain		
	#12	05.03.021.00	1
	#14	05.03.020.00	1
8	Adjustable Angle Bracket	04.25.374.00	2-4
9	End Plate, Left Side		
	6"	04.09.057.00	1
	9"	04.09.115.00	1
	15"	04.10.028.00	1
	18"	04.15.299.00	1
10	Section Cover Plate, 3"	04.08.067.00	1
11	Toggle Switch Guard	04.01.038.00	2
12	Backup Element Support Plate (includes insulation)	R04.09.056.00	2
13	End Cover, Wiring Barrier	04.37.091.00	2
14	Toggle Switch		
	100 and 120 V, 15 A (SPST)	R02.19.016.00	1-2
	208, 220, 240 V, 15 A (DPST)	R02.19.008A.00	1-2
	208, 220, 240 V, 20 A (DPST)	R02.19.006.00	1-2

Item	Description	Part No.	Qty.
15	Toggle Switch Cap/Boot		
	Slip On	02.20.283.00	1
	Threaded	02.20.040.00	1
16	Label, Toggle Switch	07.01.035.00	1
17	Indicator Plate, Toggle Switch		
	100, 120, 208, 220, 240 V	07.01.058.00	1
	220-230 and 230-240 V CE	07.01.214.00	1
18	Terminal Block (CE only)	R02.15.030.00	1
19	Infinite Switch w/ Knob		
	100 V	R02.19.160.00	1-2
	120 V	R02.19.018.00	1-2
	208 V	R02.19.017.00	1-2
	220, 240, 220-230 V, 230-240 V	R02.19.019.00	1-2
20	Knob, Infinite Switch	05.30.043.00	1-2
21	Label, Infinite Switch	07.01.034.00	1-2
22	Noise Suppression (CE only)	02.13.306.00	1
23	Indicator Light		
	Red, 100 and 120 V	02.19.154.00	1
	Red, 208 and 240 V	02.19.151.00	1
	Green (220-230 and 230-240 V)	02.19.150.00	1
24	Tandem Center Cover	04.37.080.00	1-2
	Wiring Diagrams		
	18-96" Models		
	100, 120, 208, 240 V	HS1-1442	
	220 V Export	HS1-3164	
	240 V Export	HS1-3165	
	220-230 V CE	HS1-4234	
	230-240 V CE	HS1-4235	
	108-144" Tandem Models		
	Standard Watt	HS1-2499	
	High Watt	HS1-3059	

† 120 V circuit for light only.

The shaded areas contain electrical information for **International models only**.

NOTE: Quantities shown as a range (example = "1-2") are dependent upon the width and/or depth of unit.

Wire Guards

Item	Description	Part No.	Qty.
1	Wire Guard		
	18" Models	04.37.100.00	1
	24" Models	04.37.100.00	1
	30" Models	04.37.100.00	2
	36" Models	04.37.100.00	2
	42" Models	04.37.100.00	3
	48" Models	04.37.100.00	3
	54" Models	04.37.100.00	4
	60" Models	04.37.100.00	4

Item	Description	Part No.	Qty.
1	Wire Guard		
	66" Models	04.37.100.00	5
	72" Models	04.37.100.00	5
	84" Models	04.37.100.00	6
	96" Models	04.37.100.00	7
	108" Models	04.37.100.00	8
	120" Models	04.37.100.00	8
	132" Models	04.37.100.00	10
	144" Models	04.37.100.00	10

NOTE: Dual models have twice the wire guard quantities shown.



Heating Elements for Standard Wattage Units

Item Description	Part No.	Qty.
18" Width, 250 Watt		
120 V	R02.08.031D.00	1
208 V	R02.08.040D.00	1
240 V	R02.08.035E.00	1
220 V	R02.08.037E.00	1
24" Width, 350 Watt		
120 V	R02.08.001D.00	1
208 V	R02.08.002D.00	1
240 V	R02.08.003E.00	1
220 V	R02.08.041E.00	1
30" Width, 450 Watt		
120 V	R02.08.026D.00	1
208 V	R02.08.027D.00	1
240 V	R02.08.028E.00	1
220 V	R02.08.042E.00	1
36" Width, 575 Watt		
120 V	R02.08.004D.00	1
208 V	R02.08.005D.00	1
240 V	R02.08.006E.00	1
220 V	R02.08.043E.00	1
42" Width, 675 Watt		
120 V	R02.08.007D.00	1
208 V	R02.08.008D.00	1
240 V	R02.08.009E.00	1
220 V	R02.08.039E.00	1
48" Width, 800 Watt		
120 V	R02.08.010D.00	1
208 V	R02.08.011D.00	1
240 V	R02.08.012E.00	1
220 V	R02.08.045E.00	1
54" Width, 925 Watt		
120 V	R02.08.025D.00	1
208 V	R02.08.029D.00	1
240 V	R02.08.030E.00	1
220 V	R02.08.046E.00	1
60" Width, 1050 Watt		
120 V	R02.08.013D.00	1
208 V	R02.08.014D.00	1
240 V	R02.08.015E.00	1
220 V	R02.08.047E.00	1
66" Width, 1160 Watt		
120 V	R02.08.032D.00	1
208 V	R02.08.033D.00	1
240 V	R02.08.034E.00	1
220 V	R02.08.048E.00	1

Item Description	Part No.	Qty.
72" Width, 1275 Watt		
120 V	R02.08.016D.00	1
208 V	R02.08.017D.00	1
240 V	R02.08.018E.00	1
220 V	R02.08.049E.00	1
84" Width, 1500 Watt		
120 V, 1500 Watt	R02.08.019D.00	1
120 V, 1350 Watt*	R02.08.007D.00	2
208 V	R02.08.020D.00	1
240 V	R02.08.021E.00	1
220 V	R02.08.050E.00	1
96" Width, 1725 Watt		
120 V, 1725 Watt	R02.08.022D.00	1
120 V, 1600 Watt*	R02.08.010D.00	2
208 V	R02.08.023D.00	1
240 V	R02.08.024E.00	1
220 V	R02.08.051E.00	1
108" Width, 1850 Watt*		
120 V	R02.08.025D.00	2
208 V	R02.08.029D.00	2
240 V	R02.08.030E.00	2
220 V	R02.08.046E.00	2
120" Width, 2800 Watt*		
120 V	R02.08.013D.00	2
208 V	R02.08.014D.00	2
240 V	R02.08.015E.00	2
220 V	R02.08.047E.00	2
132" Width, 2320 Watt*		
120 V	R02.08.032D.00	2
208 V	R02.08.033D.00	2
240 V	R02.08.034E.00	2
220 V	R02.08.048E.00	2
144" Width, 2550 Watt*		
120 V	R02.08.016D.00	2
208 V	R02.08.017D.00	2
240 V	R02.08.018E.00	2
220 V	R02.08.049E.00	2

NOTE: Standard Glo-Ray models in 108"-144" widths **always** contain tandem (end-to-end) elements. Custom Glo-Ray models in 36"-96" widths **may** contain tandem (end-to-end) elements, if specially made.

* Tandem models

The shaded areas contain electrical information for **International models only.**

Heating Elements for High Wattage Units

Item Description	Part No.	Qty.
18" Width, 350 Watt		
120 V	R02.08.126D.00	1
208 V	R02.08.137D.00	1
240 V	R02.08.135E.00	1
100 V	R02.08.126D.00	1
220 V	R02.08.138E.00	1
24" Width, 500 Watt		
120 V	R02.08.101D.00	1
208 V	R02.08.102D.00	1
240 V	R02.08.103E.00	1
100 V	R02.08.561E.00	1
220 V	R02.08.136E.00	1
30" Width, 660 Watt		
120 V	R02.08.127D.00	1
208 V	R02.08.128D.00	1
240 V	R02.08.129E.00	1
100 V	R02.08.562E.00	1
220 V	R02.08.139E.00	1
36" Width, 800 Watt		
120 V	R02.08.104D.00	1
208 V	R02.08.105D.00	1
240 V	R02.08.106E.00	1
100 V	R02.08.563E.00	1
220 V	R02.08.140E.00	1
42" Width, 950 Watt		
120 V	R02.08.107D.00	1
208 V	R02.08.108D.00	1
240 V	R02.08.109E.00	1
100 V	R02.08.564E.00	1
220 V	R02.08.141E.00	1
48" Width, 1100 Watt		
120 V	R02.08.110D.00	1
208 V	R02.08.111D.00	1
240 V	R02.08.112E.00	1
100 V	R02.08.566E.00	1
220 V	R02.08.142E.00	1
54" Width, 1250 Watt		
120 V	R02.08.125D.00	1
208 V	R02.08.130D.00	1
240 V	R02.08.131E.00	1
220 V	R02.08.143E.00	1
60" Width, 1400 Watt		
120 V	R02.08.113D.00	1
208 V	R02.08.114D.00	1
240 V	R02.08.115E.00	1
220 V	R02.08.144E.00	1
66" Width, 1560 Watt		
120 V, 1560 Watt Tandem	R02.08.132D.00	1
120 V, 1460 Watt	R02.08.104D.00	1
120 V, 1460 Watt	R02.08.127D.00	1
208 V	R02.08.133D.00	1
240 V	R02.08.134E.00	1
220 V	R02.08.145E.00	1

Item Description	Part No.	Qty.
72" Width, 1725 Watt		
120 V	R02.08.116D.00	1
120 V*	R02.08.104D.00	2
208 V	R02.08.117D.00	1
240 V	R02.08.118E.00	1
220 V	R02.08.148E.00	1
84" Width, 2050 Watt		
120 V, 1900 Watt	R02.08.107D.00	1
208 V	R02.08.120D.00	1
240 V	R02.08.121E.00	1
220 V	R02.08.149E.00	1
96" Width, 2400 Watt		
120 V, 2200 Watt*	R02.08.110D.00	2
208 V	R02.08.123D.00	1
208 V, 2200 Watt*	R02.08.111D.00	2
240 V	R02.08.124D.00	1
240 V, 2200 Watt*	R02.08.112E.00	2
220 V	R02.08.150E.00	1
220 V, 2200 Watt*	R02.08.142E.00	2
108" Width, 2500 Watt*		
120 V	R02.08.125D.00	2
208 V	R02.08.130D.00	2
240 V	R02.08.131E.00	2
220 V	R02.08.143E.00	2
120" Width, 2800 Watt*		
120 V	R02.08.113D.00	2
208 V	R02.08.114D.00	2
240 V	R02.08.115E.00	2
220 V	R02.08.144E.00	2
132" Width, 3120 Watt*		
120 V	R02.08.132D.00	2
208 V	R02.08.133D.00	2
240 V	R02.08.134E.00	2
220 V	R02.08.145E.00	2
144" Width, 3450 Watt*		
120 V	R02.08.116D.00	2
208 V	R02.08.117D.00	2
240 V	R02.08.118E.00	2
220 V	R02.08.148E.00	2

* Tandem models

The shaded areas contain electrical information for **International models only**.

NOTE: Standard Glo-Ray models in 108"–144" widths **always** contain tandem (end-to-end) elements. Custom Glo-Ray models in 36"–96" widths **may** contain tandem (end-to-end) elements, if specially made.

Glo-Ray® Strip Heaters

Options and Accessories

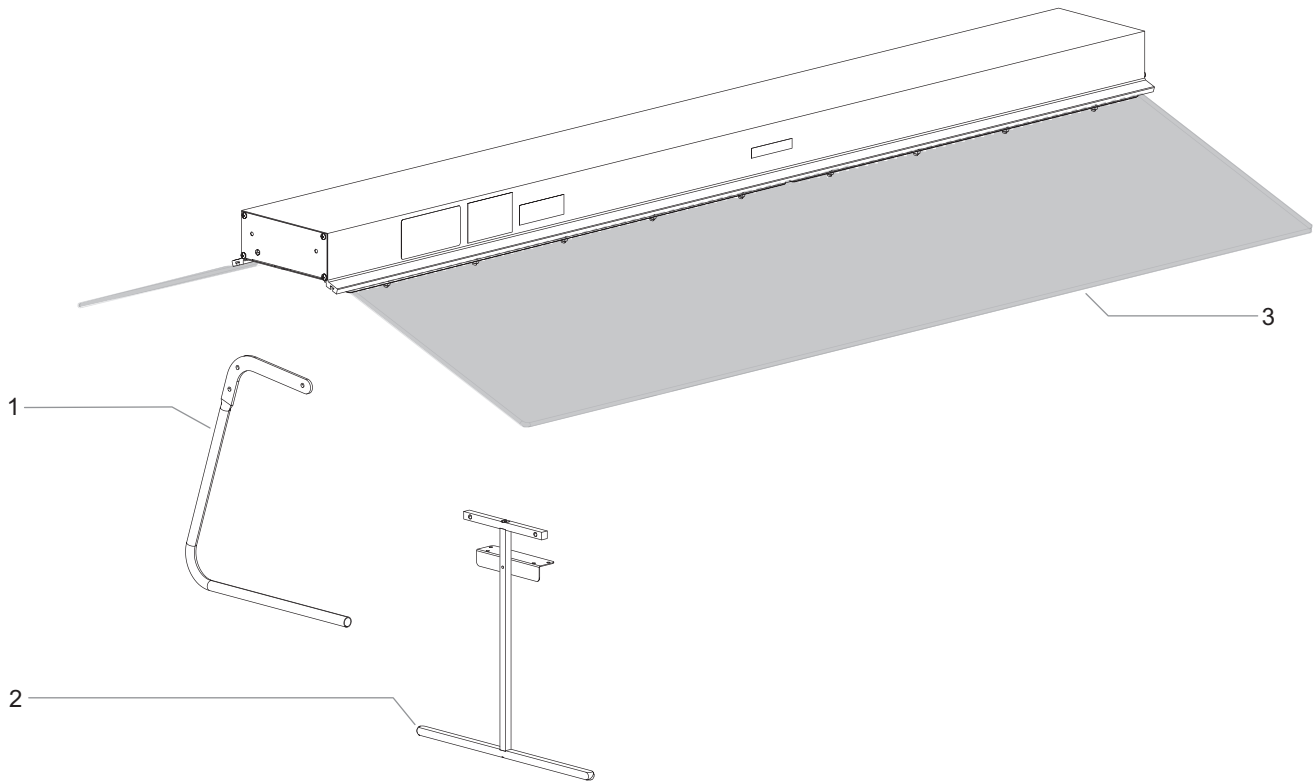

Item	Description	Part No.	Qty.
1	C-Leg Stands		
	Standard Watt, 10" Clearance	R04.08.043.00	2
	High Watt, 13-1/2" Clearance	R04.08.071.00	2
2	T-Leg Stands		
	Standard Watt, 10" Clearance	R04.08.076.00	2
	High Watt, 13-1/2" Clearance	R04.08.075.00	2
	16" Clearance	R04.08.074.00	2
	18" Clearance	R04.08.073.00	2

Item	Description	Part No.	Qty.
3	Sneeze Guards (includes hardware and metal strips)		
	18" Width, 9-3/8" Deep	R00.05.0100.00	1-2
	18" Width, 14" Deep	R04.12.136.00	1-2
	24" Width, 9-3/8" Deep	R04.12.040.00	1-2
	24" Width, 14" Deep	R04.12.130.00	1-2
	30" Width, 9-3/8" Deep	R04.12.041.00	1-2
	30" Width, 14" Deep	R04.12.092.00	1-2
	36" Width, 9-3/8" Deep	R04.12.042.00	1-2
	36" Width, 14" Deep	R04.12.080.00	1-2
	42" Width, 9-3/8" Deep	R04.12.043.00	1-2
	42" Width, 14" Deep	R04.12.209.00	1-2
	48" Width, 9-3/8" Deep	R04.12.044.00	1-2
	48" Width, 14" Deep	R04.12.210.00	1-2
	54" Width, 9-3/8" Deep	R04.12.045.00	1-2
	54" Width, 14" Deep	R04.12.211.00	1-2
	60" Width, 9-3/8" Deep	R04.12.046.00	1-2
	60" Width, 14" Deep	R04.12.212.00	1-2
	66" Width, 9-3/8" Deep	R04.12.047.00	1-2
	66" Width, 14" Deep	R04.12.240.00	1-2
	72" Width, 9-3/8" Deep	R04.12.048.00	1-2
72" Width, 14" Deep	R04.12.241.00	1-2	
84" Width, 9-3/8" Deep	R04.12.061.00	1-2	
84" Width, 14" Deep	R04.12.245.00	1-2	
96" Width, 9-3/8" Deep	R04.12.062.00	1-2	
96" Width, 14" Deep	R04.12.246.00	1-2	

AUTHORIZED PARTS DISTRIBUTORS • DISTRIBUTEURS DE PIÈCES AUTORISÉS

ALABAMA

Jones McLeod Appl. Svc.
Birmingham 205-251-0159

ARIZONA

Service Solutions Group
Phoenix 602-234-2443

Byassee Equipment Co.
Phoenix 602-252-0402

CALIFORNIA

Industrial Electric
Commercial Parts & Service, Inc.
Huntington Beach 714-379-7100

Chapman Appl. Service
San Diego 619-298-7106

P & D Appliance
Commercial Parts & Service, Inc.
S. San Francisco 650-635-1900

COLORADO

Hawkins Commercial Appliance
Englewood 303-781-5548

FLORIDA

Whaley Foodservice Repair
Jacksonville 904-725-7800

Whaley Foodservice Repair
Orlando 407-757-0851

B.G.S.I.
Pompano Beach 954-971-0456

Comm. Appliance Service
Tampa 813-663-0313

GEORGIA

TWC Services
Mableton 770-438-9797

Heritage Service Group
Norcross 866-388-9837

Southeastern Rest. Svc.
Norcross 770-446-6177

HAWAII

Burney's Comm. Service, Inc.
Honolulu 808-848-1466

Food Equip Parts & Service
Honolulu 808-847-4871

ILLINOIS

Parts Town
Lombard 708-865-7278

Eichenauer Elec. Service
Decatur 217-429-4229

Midwest Elec. Appl. Service
Elmhurst 630-279-8000

Cone's Repair Service
Moline 309-797-5323

INDIANA

GCS Service
Indianapolis 800-727-8710

IOWA

Goodwin Tucker Group
Des Moines 515-262-9308

KENTUCKY

Service Solutions Group
Lexington 859-254-8854

Service Solutions Group
Louisville 502-451-5411

LOUISIANA

Chandlers Parts & Service
Baton Rouge 225-272-6620

MARYLAND

Electric Motor Service
Baltimore 410-467-8080

GCS Service
Silver Spring 301-585-7550

MASSACHUSETTS

Ace Service Co., Inc.
Needham 781-449-4220

MICHIGAN

Bildons Appliance Service
Detroit 248-478-3320

Commercial Kitchen Service
Bay City 989-893-4561

Midwest Food Equip. Service
Grandville 616-261-2000

MINNESOTA

GCS Service
Minnetonka 800-822-2303
x20365

MISSOURI

General Parts
Kansas City 816-421-5400

Commercial Kitchen Services
St. Louis 314-890-0700

Kaemmerlen Parts & Service
St. Louis 314-535-2222

NEBRASKA

Anderson Electric
Omaha 402-341-1414

NEVADA

Burney's Commercial
Las Vegas 702-736-0006

Hi. Tech Commercial Service
N. Las Vegas 702-649-4616

NEW JERSEY

Jay Hill Repair
Fairfield 973-575-9145

Service Plus
Flanders 973-691-6300

NEW YORK

Acme American Repairs, Inc.
Jamaica 718-456-6544

Alpro Service Co.
Maspeth 718-386-2515

Appliance Installation
Buffalo 716-884-7425

Duffy's Equipment Services, Inc.
Buffalo 800-836-1014

3Wire Northern
Plattsburgh 800-634-5005

Duffy's Equipment Services, Inc.
Sauquoit 800-836-1014

J.B. Brady, Inc.
Syracuse 315-422-9271

NORTH CAROLINA

Authorized Appliance
Charlotte 704-377-4501

OHIO

Akron/Canton Comm. Svc. Inc.
Akron 330-753-6634

Service Solutions Group
Cincinnati 513-772-6600

Commercial Parts and Service
Columbus 614-221-0057

Electrical Appl. Repair Service
Brooklyn Heights 216-459-8700

E. A. Wichman Co.
Toledo 419-385-9121

OKLAHOMA

Hagar Rest. Service, Inc.
Oklahoma City 405-235-2184

Krueger, Inc.
Oklahoma City 405-528-8883

OREGON

Ron's Service, Inc.
Portland 503-624-0890

PENNSYLVANIA

Elmer Schultz Services
Philadelphia 215-627-5401

FAST Comm. Appl. Service
Philadelphia 215-288-4800

Appliance Installation & Service
Pittsburgh 412-809-0244

K & D Service Co.
Harrisburg 717-236-9039

Electric Repair Co.
Reading 610-376-5444

RHODE ISLAND

Marshall Electric Co.
Providence 401-331-1163

SOUTH CAROLINA

Whaley Foodservice Repair
Lexington 803-996-9900

TENNESSEE

Camp Electric
Memphis 901-527-7543

TEXAS

GCS Service
Fort Worth 800-433-1804

Armstrong Repair Service
Houston 713-666-7100

Cooking Equipment Specialist
Mesquite 972-686-6666

Commercial Kitchen Repair Co.
San Antonio 210-735-2811

UTAH

La Monica's Rest. Equip. Service
Murray 801-263-3221

VIRGINIA

Daubers
Norfolk 757-855-4097

Daubers
Springfield 703-866-3600

WASHINGTON

3Wire Restaurant Appliance
Seattle 800-207-3146

WISCONSIN

A.S.C., Inc.
Madison 608-246-3160

A.S.C., Inc.
Milwaukee 414-543-6460

CANADA

ALBERTA

Key Food Equipment Service
Edmonton 780-438-1690

BRITISH COLUMBIA

Key Food Equipment Service
Vancouver 604-433-4484

Key Food Equipment Service
Victoria 250-920-4888

MANITOBA

Air Rite, Inc.
Winnipeg 204-895-2300

NEW BRUNSWICK

EMR Services, Ltd.
Moncton 506-855-4228

ONTARIO

R.G. Henderson Ltd.
Toronto 416-422-5580

Choquette - CKS, Inc.
Ottawa 613-739-8458

QUÉBEC

Choquette - CKS, Inc.
Montreal 514-722-2000

Choquette - CKS, Inc.
Québec City 418-681-3944

UNITED KINGDOM

Marren Group
Northants +44(0)1933 665313

HATCO CORPORATION

P.O. Box 340500

Milwaukee, WI 53234-0500 U.S.A.

800-558-0607 414-671-6350

partsandservice@hatcocorp.com

www.hatcocorp.com



24 Hour 7 Day Parts and Service
Assistance available in the United States
and Canada by calling 800-558-0607.