



GLO-RAY[®] Pizza Warmers

GRPWS Series

<i>GRPWS-2418D</i>	<i>GRPWS-2418T</i>	<i>GRPWS-2418Q</i>
<i>GRPWS-3618D</i>	<i>GRPWS-3618T</i>	<i>GRPWS-3618Q</i>
<i>GRPWS-4818D</i>	<i>GRPWS-4818T</i>	<i>GRPWS-4818Q</i>
<i>GRPWS-2424D</i>	<i>GRPWS-2424T</i>	<i>GRPWS-2424Q</i>
<i>GRPWS-3624D</i>	<i>GRPWS-3624T</i>	<i>GRPWS-3624Q</i>
<i>GRPWS-4824D</i>	<i>GRPWS-4824T</i>	<i>GRPWS-4824Q</i>

**REPLACEMENT
PARTS LIST**

HATCO GLO-RAY® PIZZA WARMERS GRPWS SERIES

Model Designation

GRPWS-XX XX X	G = Glo-
	R = Ray
	P = Pizza
	W = Warmer
	S = Slant
	XX = Width (inches)
	XX = Depth (inches)
	D = Dual Shelf
	T = Triple Shelf
	Q = Quad Shelf

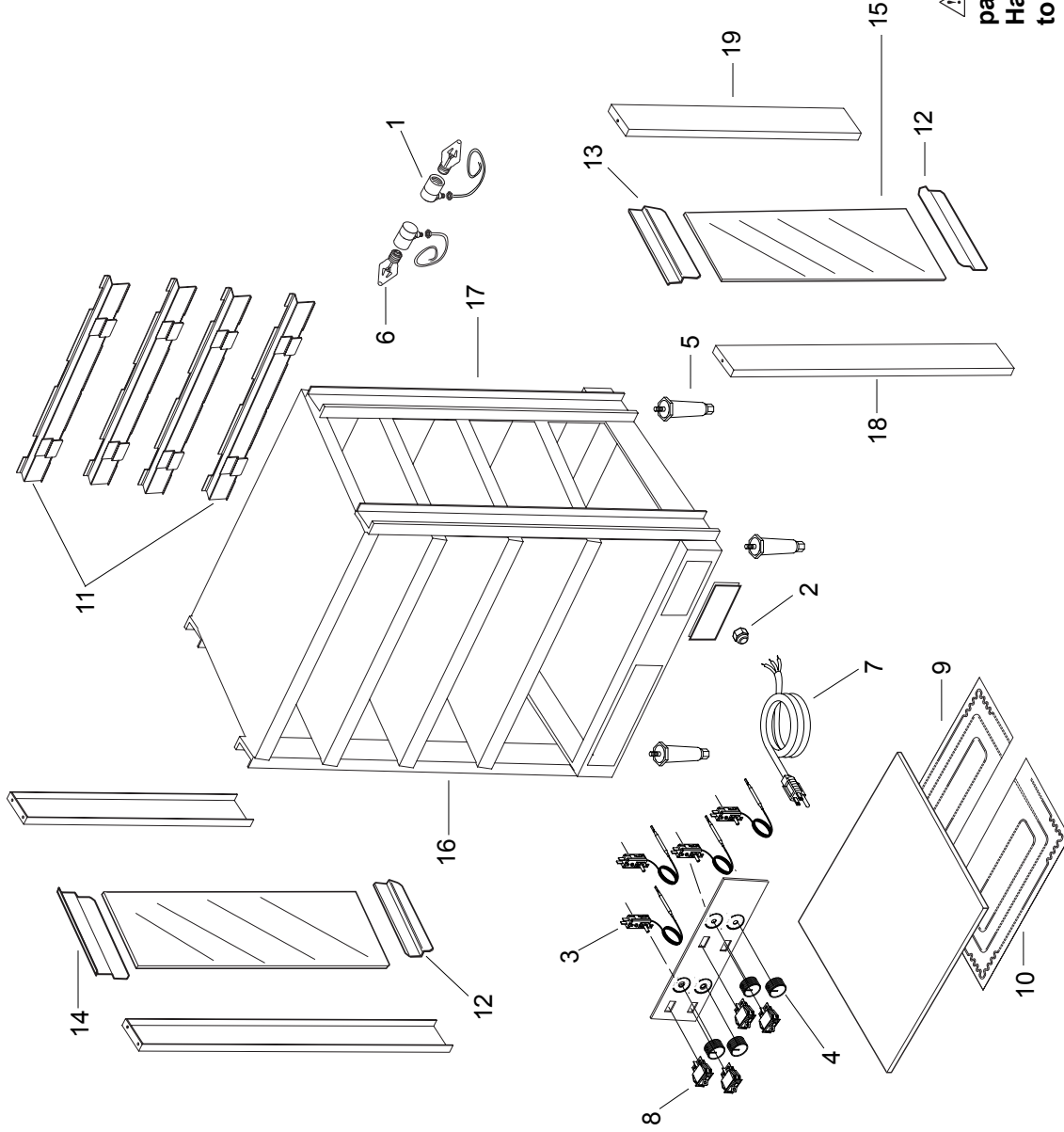

CAUTION - Use of replacement parts other than those supplied by Hatco Corporation may result in damage to the unit or injury to personnel.

PARTS COMMON TO ALL MODELS

ITEM	DESCRIPTION	PART NO.	QTY.	ITEM	DESCRIPTION	PART NO.	QTY.
1	Light Socket with Leads	02.30.044.00	2-16	4	Knob, Thermostat	05.30.039.00	2-4
2	Cord Grip	02.20.259.00	1	5	4" (10 cm) Appliance Legs	05.30.007.00	4
3	Thermostat Control	R02.16.039.00	2-4				

PARTS SPECIFIC TO MODEL GRPWS-2418D

ITEM	DESCRIPTION	120V	120V Canada	120/208V	120/240V	220V	240V	220-230V CE	230-240V CE
6	Light Bulb (Qty. 4)	02.30.043.00	02.30.043.00	---	---	---	---	---	---
7	Cord & Plug	R02.18.030.00	R02.18.030.00	---	---	---	---	---	---
8	On/Off Switch (Qty. 2)	02.19.080.00	02.19.080.00	---	---	---	---	---	---
9	Heating Element, Front (Qty. 2)	02.05.468.00	02.05.468.00	---	---	---	---	---	---
10	Heating Element, Rear (Qty. 2)	02.05.462.00	02.05.462.00	---	---	---	---	---	---
11	Box Stop (Qty. 2)	04.29.071.00	04.29.071.00	---	---	---	---	---	---
12	Glass Bracket, Lower (Qty. 2)	04.29.017.00	04.29.017.00	---	---	---	---	---	---
13	Glass Bracket, LH Upper	04.29.018.00	04.29.018.00	---	---	---	---	---	---
14	Glass Bracket, RH Upper	04.29.019.00	04.29.019.00	---	---	---	---	---	---
15	Glass Panel (Qty. 2)	04.40.133.00	04.40.133.00	---	---	---	---	---	---
16	Support Post, Rear (Qty. 2)	04.29.122.00	04.29.122.00	---	---	---	---	---	---
17	Support Post, Front (Qty. 2)	04.29.124.00	04.29.124.00	---	---	---	---	---	---
18	Post Cover, Rear (Qty. 2)	04.29.126.00	04.29.126.00	---	---	---	---	---	---
19	Post Cover, Front (Qty. 2)	04.29.128.00	04.29.128.00	---	---	---	---	---	---
	Electrical Diagram	HS2-5079	HS2-5079	---	---	---	---	---	---

PARTS SPECIFIC TO MODEL GRPWS-3618D

ITEM	DESCRIPTION	120V	120V Canada	120/208V	120/240V	220V	240V	220-230V CE	230-240V CE
6	Light Bulb (Qty. 6)	02.30.043.00	---	---	---	---	---	---	---
7	Cord & Plug	R02.18.030.00	---	---	---	---	---	---	---
8	On/Off Switch (Qty. 2)	02.19.080.00	---	---	---	---	---	---	---
9	Heating Element, Front (Qty. 2)	02.05.470.00	---	---	---	---	---	---	---
10	Heating Element, Rear (Qty. 2)	02.05.464.00	---	---	---	---	---	---	---
11	Box Stop (Qty. 2)	04.29.073.00	---	---	---	---	---	---	---
12	Glass Bracket, Lower (Qty. 2)	04.29.017.00	---	---	---	---	---	---	---
13	Glass Bracket, LH Upper	04.29.018.00	---	---	---	---	---	---	---
14	Glass Bracket, RH Upper	04.29.019.00	---	---	---	---	---	---	---
15	Glass Panel (Qty. 2)	04.40.133.00	---	---	---	---	---	---	---
16	Support Post, Rear (Qty. 2)	04.29.122.00	---	---	---	---	---	---	---
17	Support Post, Front (Qty. 2)	04.29.124.00	---	---	---	---	---	---	---
18	Post Cover, Rear (Qty. 2)	04.29.126.00	---	---	---	---	---	---	---
19	Post Cover, Front (Qty. 2)	04.29.128.00	---	---	---	---	---	---	---
	Electrical Diagram	HS2-5079	---	---	---	---	---	---	---

Shaded area reflects export models only.

PARTS SPECIFIC TO MODEL GRPWS-4818D

ITEM	DESCRIPTION	120V	120V Canada	120/208V	120/240V	220V	240V	220-230V CE	230-240V CE
6	Light Bulb (Qty. 8)	02.30.043.00	02.30.043.00	---	---	---	---	---	---
7	Cord & Plug	R02.18.030.00	R02.18.030.00	---	---	---	---	---	---
8	On/Off Switch (Qty. 2)	02.19.080.00	02.19.080.00	---	---	---	---	---	---
9	Heating Element, Front (Qty. 2)	02.05.460.00	02.05.460.00	---	---	---	---	---	---
10	Heating Element, Rear (Qty. 2)	02.05.461.00	02.05.461.00	---	---	---	---	---	---
11	Box Stop (Qty. 2)	04.29.028.00	04.29.028.00	---	---	---	---	---	---
12	Glass Bracket, Lower (Qty. 2)	04.29.017.00	04.29.017.00	---	---	---	---	---	---
13	Glass Bracket, LH Upper	04.29.018.00	04.29.018.00	---	---	---	---	---	---
14	Glass Bracket, RH Upper	04.29.019.00	04.29.019.00	---	---	---	---	---	---
15	Glass Panel (Qty. 2)	04.40.133.00	04.40.133.00	---	---	---	---	---	---
16	Support Post, Rear (Qty. 2)	04.29.122.00	04.29.122.00	---	---	---	---	---	---
17	Support Post, Front (Qty. 2)	04.29.124.00	04.29.124.00	---	---	---	---	---	---
18	Post Cover, Rear (Qty. 2)	04.29.126.00	04.29.126.00	---	---	---	---	---	---
19	Post Cover, Front (Qty. 2)	04.29.128.00	04.29.128.00	---	---	---	---	---	---
	Electrical Diagram	HS2-5079	HS2-5079	---	---	---	---	---	---

PARTS SPECIFIC TO MODEL GRPWS-2424D

ITEM	DESCRIPTION	120V	120V Canada	120/208V	120/240V	220V	240V	220-230V CE	230-240V CE
6	Light Bulb (Qty. 4)	02.30.043.00	02.30.043.00	---	---	---	---	---	---
7	Cord & Plug	R02.18.030.00	R02.18.030.00	---	---	---	---	---	---
8	On/Off Switch (Qty. 2)	02.19.080.00	02.19.080.00	---	---	---	---	---	---
9	Heating Element, Front (Qty. 2)	02.05.468.00	02.05.468.00	---	---	---	---	---	---
10	Heating Element, Rear (Qty. 2)	02.05.475.00	02.05.475.00	---	---	---	---	---	---
11	Box Stop (Qty. 2)	04.29.071.00	04.29.071.00	---	---	---	---	---	---
12	Glass Bracket, Lower (Qty. 2)	04.15.796.00	04.15.796.00	---	---	---	---	---	---
13	Glass Bracket, LH Upper	04.29.035.00	04.29.035.00	---	---	---	---	---	---
14	Glass Bracket, RH Upper	04.29.036.00	04.29.036.00	---	---	---	---	---	---
15	Glass Panel (Qty. 2)	04.40.135.00	04.40.135.00	---	---	---	---	---	---
16	Support Post, Rear (Qty. 2)	04.29.130.00	04.29.130.00	---	---	---	---	---	---
17	Support Post, Front (Qty. 2)	04.29.124.00	04.29.124.00	---	---	---	---	---	---
18	Post Cover, Rear (Qty. 2)	04.29.133.00	04.29.133.00	---	---	---	---	---	---
19	Post Cover, Front (Qty. 2)	04.29.128.00	04.29.128.00	---	---	---	---	---	---
	Electrical Diagram	HS2-5079	HS2-5079	---	---	---	---	---	---

Shaded area reflects export models only.

PARTS SPECIFIC TO MODEL GRPWS-3624D

ITEM	DESCRIPTION	120V	120V Canada	120/208V	120/240V	220V	240V	220-230V CE	230-240V CE
6	Light Bulb (Qty. 6)	02.30.043.00	02.30.043.00	---	---	---	---	---	---
7	Cord & Plug	R02.18.030.00	R02.18.030.00	---	---	---	---	---	---
8	On/Off Switch (Qty. 2)	02.19.080.00	02.19.080.00	---	---	---	---	---	---
9	Heating Element, Front (Qty. 2)	02.05.470.00	02.05.470.00	---	---	---	---	---	---
10	Heating Element, Rear (Qty. 2)	02.05.477.00	02.05.477.00	---	---	---	---	---	---
11	Box Stop (Qty. 2)	04.29.073.00	04.29.073.00	---	---	---	---	---	---
12	Glass Bracket, Lower (Qty. 2)	04.15.796.00	04.15.796.00	---	---	---	---	---	---
13	Glass Bracket, LH Upper	04.29.035.00	04.29.035.00	---	---	---	---	---	---
14	Glass Bracket, RH Upper	04.29.036.00	04.29.036.00	---	---	---	---	---	---
15	Glass Panel (Qty. 2)	04.40.135.00	04.40.135.00	---	---	---	---	---	---
16	Support Post, Rear (Qty. 2)	04.29.130.00	04.29.130.00	---	---	---	---	---	---
17	Support Post, Front (Qty. 2)	04.29.124.00	04.29.124.00	---	---	---	---	---	---
18	Post Cover, Rear (Qty. 2)	04.29.133.00	04.29.133.00	---	---	---	---	---	---
19	Post Cover, Front (Qty. 2)	04.29.128.00	04.29.128.00	---	---	---	---	---	---
	Electrical Diagram	HS2-5079	HS2-5079	---	---	---	---	---	---

PARTS SPECIFIC TO MODEL GRPWS-4824D

ITEM	DESCRIPTION	120V	120V Canada	120/208V	120/240V	220V	240V	220-230V CE	230-240V CE
6	Light Bulb (Qty. 8)	02.30.043.00	02.30.043.00	---	---	---	---	---	---
7	Cord & Plug	R02.18.030.00	02.18.083.00	---	---	---	---	---	---
8	On/Off Switch (Qty. 2)	02.19.080.00	02.19.080.00	---	---	---	---	---	---
9	Heating Element, Front (Qty. 2)	02.05.460.00	02.05.460.00	---	---	---	---	---	---
10	Heating Element, Rear (Qty. 2)	02.05.474.00	02.05.474.00	---	---	---	---	---	---
11	Box Stop (Qty. 2)	04.29.028.00	04.29.028.00	---	---	---	---	---	---
12	Glass Bracket, Lower (Qty. 2)	04.15.796.00	04.15.796.00	---	---	---	---	---	---
13	Glass Bracket, LH Upper	04.29.035.00	04.29.035.00	---	---	---	---	---	---
14	Glass Bracket, RH Upper	04.29.036.00	04.29.036.00	---	---	---	---	---	---
15	Glass Panel (Qty. 2)	04.40.135.00	04.40.135.00	---	---	---	---	---	---
16	Support Post, Rear (Qty. 2)	04.29.130.00	04.29.130.00	---	---	---	---	---	---
17	Support Post, Front (Qty. 2)	04.29.124.00	04.29.124.00	---	---	---	---	---	---
18	Post Cover, Rear (Qty. 2)	04.29.133.00	04.29.133.00	---	---	---	---	---	---
19	Post Cover, Front (Qty. 2)	04.29.128.00	04.29.128.00	---	---	---	---	---	---
	Electrical Diagram	HS2-5079	HS2-5079	---	---	---	---	---	---

Shaded area reflects export models only.

PARTS SPECIFIC TO MODEL GRPWS-2418T

ITEM	DESCRIPTION	120V	120V Canada	120/208V	120/240V	220V	240V	220-230V CE	230-240V CE
6	Light Bulb (Qty. 6)	02.30.043.00	02.30.043.00	---	---	---	---	---	---
7	Cord & Plug	R02.18.030.00	R02.18.030.00	---	---	---	---	---	---
8	On/Off Switch (Qty. 3)	02.19.080.00	02.19.080.00	---	---	---	---	---	---
9	Heating Element, Front (Qty. 3)	02.05.468.00	02.05.468.00	---	---	---	---	---	---
10	Heating Element, Rear (Qty. 3)	02.05.462.00	02.05.462.00	---	---	---	---	---	---
11	Box Stop (Qty. 3)	04.29.071.00	04.29.071.00	---	---	---	---	---	---
12	Glass Bracket, Lower (Qty. 2)	04.29.017.00	04.29.017.00	---	---	---	---	---	---
13	Glass Bracket, LH Upper	04.29.018.00	04.29.018.00	---	---	---	---	---	---
14	Glass Bracket, RH Upper	04.29.019.00	04.29.019.00	---	---	---	---	---	---
15	Glass Panel (Qty. 2)	04.40.131.00	04.40.131.00	---	---	---	---	---	---
16	Support Post, Rear (Qty. 2)	04.09.024.00	04.09.024.00	---	---	---	---	---	---
17	Support Post, Front (Qty. 2)	04.09.023.00	04.09.023.00	---	---	---	---	---	---
18	Post Cover, Rear (Qty. 2)	04.29.026.00	04.09.026.00	---	---	---	---	---	---
19	Post Cover, Front (Qty. 2)	04.29.025.00	04.09.025.00	---	---	---	---	---	---
	Electrical Diagram	HS2-4900	HS2-4900	---	---	---	---	---	---

PARTS SPECIFIC TO MODEL GRPWS-3618T

ITEM	DESCRIPTION	120V	120V Canada	120/208V	120/240V	220V	240V	220-230V CE	230-240V CE
6	Light Bulb (Qty. 9)	02.30.043.00	02.30.043.00	---	---	---	---	---	---
7	Cord & Plug	R02.18.030.00	R02.18.083.00	---	---	---	---	---	---
8	On/Off Switch (Qty. 3)	02.19.080.00	02.19.080.00	---	---	---	---	---	---
9	Heating Element, Front (Qty. 3)	02.05.470.00	02.05.470.00	---	---	---	---	---	---
10	Heating Element, Rear (Qty. 3)	02.05.464.00	02.05.464.00	---	---	---	---	---	---
11	Box Stop (Qty. 3)	04.29.073.00	04.29.073.00	---	---	---	---	---	---
12	Glass Bracket, Lower (Qty. 2)	04.29.017.00	04.29.017.00	---	---	---	---	---	---
13	Glass Bracket, LH Upper	04.29.018.00	04.29.018.00	---	---	---	---	---	---
14	Glass Bracket, RH Upper	04.29.019.00	04.29.019.00	---	---	---	---	---	---
15	Glass Panel (Qty. 2)	04.40.131.00	04.40.131.00	---	---	---	---	---	---
16	Support Post, Rear (Qty. 2)	04.29.024.00	04.29.024.00	---	---	---	---	---	---
17	Support Post, Front (Qty. 2)	04.29.023.00	04.29.023.00	---	---	---	---	---	---
18	Post Cover, Rear (Qty. 2)	04.29.026.00	04.29.026.00	---	---	---	---	---	---
19	Post Cover, Front (Qty. 2)	04.29.025.00	04.09.025.00	---	---	---	---	---	---
	Electrical Diagram	HS2-4900	HS2-4900	---	---	---	---	---	---

Shaded area reflects export models only.

PARTS SPECIFIC TO MODEL GRPWS-4818T

ITEM	DESCRIPTION	120V	120V Canada	120/208V	120/240V	220V	240V	220-230V CE	230-240V CE
6	Light Bulb (Qty. 12)	02.30.043.00	---	02.30.043.00	02.30.043.00	---	---	---	---
7	Cord & Plug	R02.18.083.00	---	02.18.085.00	02.18.085.00	---	---	---	---
8	On/Off Switch (Qty. 3)	02.19.080.00	---	02.19.080.00	02.19.080.00	---	---	---	---
9	Heating Element, Front (Qty. 3)	02.05.460.00	---	02.05.460.00	02.05.460.00	---	---	---	---
10	Heating Element, Rear (Qty. 3)	02.05.461.00	---	02.05.461.00	02.05.461.00	---	---	---	---
11	Box Stop (Qty. 3)	04.29.028.00	---	04.29.028.00	04.29.028.00	---	---	---	---
12	Glass Bracket, Lower (Qty. 2)	04.29.017.00	---	04.29.017.00	04.29.017.00	---	---	---	---
13	Glass Bracket, LH Upper	04.29.018.00	---	04.29.018.00	04.29.018.00	---	---	---	---
14	Glass Bracket, RH Upper	04.29.019.00	---	04.29.019.00	04.29.019.00	---	---	---	---
15	Glass Panel (Qty. 2)	04.40.131.00	---	04.40.131.00	04.40.131.00	---	---	---	---
16	Support Post, Rear (Qty. 2)	04.29.024.00	---	04.29.024.00	04.29.024.00	---	---	---	---
17	Support Post, Front (Qty. 2)	04.29.023.00	---	04.29.023.00	04.29.023.00	---	---	---	---
18	Post Cover, Rear (Qty. 2)	04.29.026.00	---	04.29.026.00	04.29.026.00	---	---	---	---
19	Post Cover, Front (Qty. 2)	04.29.025.00	---	04.29.025.00	04.29.025.00	---	---	---	---
	Electrical Diagram	HS2-4900	---	HS2-5076	HS2-5076	---	---	---	---

PARTS SPECIFIC TO MODEL GRPWS-2424T

ITEM	DESCRIPTION	120V	120V Canada	120/208V	120/240V	220V	240V	220-230V CE	230-240V CE
6	Light Bulb (Qty. 6)	02.30.043.00	02.30.043.00	---	---	---	---	02.30.058.00	02.30.058.00
7	Cord & Plug	R02.18.030.00	R02.18.030.00	---	---	---	---	02.18.077.00	02.18.068.00
8	On/Off Switch (Qty. 3)	02.19.080.00	02.19.080.00	---	---	---	---	02.19.081.00	02.19.081.00
9	Heating Element, Front (Qty. 3)	02.05.468.00	02.05.468.00	---	---	---	---	02.05.530.00	02.05.530.00
10	Heating Element, Rear (Qty. 3)	02.05.475.00	02.05.475.00	---	---	---	---	02.05.529.00	02.05.529.00
11	Box Stop (Qty. 3)	04.29.071.00	04.29.071.00	---	---	---	---	04.29.071.00	04.29.071.00
12	Glass Bracket, Lower (Qty. 2)	04.15.796.00	04.15.796.00	---	---	---	---	04.15.796.00	04.15.796.00
13	Glass Bracket, LH Upper	04.25.035.00	04.25.035.00	---	---	---	---	04.29.035.00	04.29.035.00
14	Glass Bracket, RH Upper	04.25.036.00	04.25.036.00	---	---	---	---	04.29.036.00	04.29.036.00
15	Glass Panel (Qty. 2)	04.40.136.00	04.40.136.00	---	---	---	---	04.40.136.00	04.40.136.00
16	Support Post, Rear (Qty. 2)	04.29.131.00	04.29.131.00	---	---	---	---	04.29.131.00	04.29.131.00
17	Support Post, Front (Qty. 2)	04.29.023.00	04.29.023.00	---	---	---	---	04.29.023.00	04.29.023.00
18	Post Cover, Rear (Qty. 2)	04.29.134.00	04.29.134.00	---	---	---	---	04.29.134.00	04.29.134.00
19	Post Cover, Front (Qty. 2)	04.29.025.00	04.29.025.00	---	---	---	---	04.29.025.00	04.29.025.00
	Electrical Diagram	HS2-4900	HS2-4900	---	---	---	---	HS2-5302	HS2-5302

Shaded area reflects export models only.

PARTS SPECIFIC TO MODEL GRPWS-3624T

ITEM	DESCRIPTION	120V	120V Canada	120/208V	120/240V	220V	240V	220-230V CE	230-240V CE
6	Light Bulb (Qty. 9)	02.30.043.00	---	02.30.043.00	02.30.043.00	02.30.058.00	02.30.058.00	02.30.058.00	02.30.058.00
7	Cord & Plug	R02.18.083.00	---	02.18.085.00	02.18.085.00	02.18.077.00	02.18.068.00	02.18.077.00	02.18.068.00
8	On/Off Switch (Qty. 3)	02.19.080.00	---	02.19.080.00	02.19.080.00	02.19.081.00	02.19.081.00	02.19.081.00	02.19.081.00
9	Heating Element, Front (Qty. 3)	02.05.470.00	---	02.05.470.00	02.05.470.00	02.05.487.00	02.05.487.00	02.05.487.00	02.05.487.00
10	Heating Element, Rear (Qty. 3)	02.05.477.00	---	02.05.477.00	02.05.477.00	02.05.489.00	02.05.489.00	02.05.489.00	02.05.489.00
11	Box Stop (Qty. 3)	04.29.073.00	---	04.29.073.00	04.29.073.00	04.29.073.00	04.29.073.00	04.29.073.00	04.29.073.00
12	Glass Bracket, Lower (Qty. 2)	04.15.796.00	---	04.15.796.00	04.15.796.00	04.15.796.00	04.15.796.00	04.15.796.00	04.15.796.00
13	Glass Bracket, LH Upper	04.29.035.00	---	04.29.035.00	04.29.035.00	04.29.035.00	04.29.035.00	04.29.035.00	04.29.035.00
14	Glass Bracket, RH Upper	04.29.036.00	---	04.29.036.00	04.29.036.00	04.29.036.00	04.29.036.00	04.29.036.00	04.29.036.00
15	Glass Panel (Qty. 2)	04.40.136.00	---	04.40.136.00	04.40.136.00	04.40.136.00	04.40.136.00	04.40.136.00	04.40.136.00
16	Support Post, Rear (Qty. 2)	04.29.131.00	---	04.29.131.00	04.29.131.00	04.29.131.00	04.29.131.00	04.29.131.00	04.29.131.00
17	Support Post, Front (Qty. 2)	04.29.023.00	---	04.29.023.00	04.29.023.00	04.29.023.00	04.29.023.00	04.29.023.00	04.29.023.00
18	Post Cover, Rear (Qty. 2)	04.29.134.00	---	04.29.134.00	04.29.134.00	04.29.134.00	04.29.134.00	04.29.134.00	04.29.134.00
19	Post Cover, Front (Qty. 2)	04.29.025.00	---	04.29.025.00	04.29.025.00	04.29.025.00	04.29.025.00	04.29.025.00	04.29.025.00
	Electrical Diagram	HS2-4900	---	HS2-5076	HS2-5076	HS2-5302	HS2-5302	HS2-5302	HS2-5302

PARTS SPECIFIC TO MODEL GRPWS-4824T

ITEM	DESCRIPTION	120V	120V Canada	120/208V	120/240V	220V	240V	220-230V CE	230-240V CE
6	Light Bulb (Qty. 12)	---	---	02.30.043.00	02.30.043.00	02.30.058.00	02.30.058.00	02.30.058.00	02.30.058.00
7	Cord & Plug	---	---	02.18.085.00	02.18.085.00	02.18.038.00	02.18.068.00	02.18.038.00	02.18.068.00
8	On/Off Switch (Qty. 3)	---	---	02.19.080.00	02.19.080.00	02.19.081.00	02.19.081.00	02.19.081.00	02.19.081.00
9	Heating Element, Front (Qty. 3)	---	---	02.05.460.00	02.05.460.00	02.05.488.00	02.05.488.00	02.05.488.00	02.05.488.00
10	Heating Element, Rear (Qty. 3)	---	---	02.05.474.00	02.05.474.00	02.05.490.00	02.05.490.00	02.05.490.00	02.05.490.00
11	Box Stop (Qty. 3)	---	---	04.29.028.00	04.29.028.00	04.29.028.00	04.29.028.00	04.29.028.00	04.29.028.00
12	Glass Bracket, Lower (Qty. 2)	---	---	04.15.796.00	04.15.796.00	04.15.796.00	04.15.796.00	04.15.796.00	04.15.796.00
13	Glass Bracket, LH Upper	---	---	04.29.035.00	04.29.035.00	04.29.035.00	04.29.035.00	04.29.035.00	04.29.035.00
14	Glass Bracket, RH Upper	---	---	04.29.036.00	04.29.036.00	04.29.036.00	04.29.036.00	04.29.036.00	04.29.036.00
15	Glass Panel (Qty. 2)	---	---	04.40.136.00	04.40.136.00	04.40.136.00	04.40.136.00	04.40.136.00	04.40.136.00
16	Support Post, Rear (Qty. 2)	---	---	04.29.131.00	04.29.131.00	04.29.131.00	04.29.131.00	04.29.131.00	04.29.131.00
17	Support Post, Front (Qty. 2)	---	---	04.29.023.00	04.29.023.00	04.29.023.00	04.29.023.00	04.29.023.00	04.29.023.00
18	Post Cover, Rear (Qty. 2)	---	---	04.29.134.00	04.29.134.00	04.29.134.00	04.29.134.00	04.29.134.00	04.29.134.00
19	Post Cover, Front (Qty. 2)	---	---	04.29.025.00	04.29.025.00	04.29.025.00	04.29.025.00	04.29.025.00	04.29.025.00
	Electrical Diagram	---	---	HS2-5076	HS2-5076	HS2-5302	HS2-5302	HS2-5302	HS2-5302

Shaded area reflects export models only.

PARTS SPECIFIC TO MODEL GRPWS-2418Q

ITEM	DESCRIPTION	120V	120V Canada	120/208V	120/240V	220V	240V	220-230V CE	230-240V CE
6	Light Bulb (Qty. 8)	02.30.043.00	02.30.043.00	---	---	---	---	---	---
7	Cord & Plug	R02.18.030.00	R02.18.083.00	---	---	---	---	---	---
8	On/Off Switch (Qty. 4)	02.19.080.00	02.19.080.00	---	---	---	---	---	---
9	Heating Element, Front (Qty. 4)	02.05.468.00	02.05.468.00	---	---	---	---	---	---
10	Heating Element, Rear (Qty. 4)	02.05.462.00	02.05.462.00	---	---	---	---	---	---
11	Box Stop (Qty. 4)	04.29.071.00	04.29.071.00	---	---	---	---	---	---
12	Glass Bracket, Lower (Qty. 2)	04.29.017.00	04.29.017.00	---	---	---	---	---	---
13	Glass Bracket, LH Upper	04.29.018.00	04.29.018.00	---	---	---	---	---	---
14	Glass Bracket, RH Upper	04.29.019.00	04.29.019.00	---	---	---	---	---	---
15	Glass Panel (Qty. 2)	04.40.134.00	04.40.134.00	---	---	---	---	---	---
16	Support Post, Rear (Qty. 2)	04.29.123.00	04.29.123.00	---	---	---	---	---	---
17	Support Post, Front (Qty. 2)	04.29.125.00	04.29.125.00	---	---	---	---	---	---
18	Post Cover, Rear (Qty. 2)	04.29.127.00	04.29.127.00	---	---	---	---	---	---
19	Post Cover, Front (Qty. 2)	04.29.129.00	04.29.129.00	---	---	---	---	---	---
	Electrical Diagram	HS2-5082	HS2-5082	---	---	---	---	---	---

PARTS SPECIFIC TO MODEL GRPWS-3618Q

ITEM	DESCRIPTION	120V	120V Canada	120/208V	120/240V	220V	240V	220-230V CE	230-240V CE
6	Light Bulb (Qty. 12)	02.30.043.00	02.30.043.00	02.30.043.00	02.30.043.00	---	---	---	---
7	Cord & Plug	R02.18.083.00	R02.18.083.00	02.18.085.00	02.18.085.00	---	---	---	---
8	On/Off Switch (Qty. 4)	02.19.080.00	02.19.080.00	02.19.080.00	02.19.080.00	---	---	---	---
9	Heating Element, Front (Qty. 4)	02.05.470.00	02.05.470.00	02.05.470.00	02.05.470.00	---	---	---	---
10	Heating Element, Rear (Qty. 4)	02.05.464.00	02.05.464.00	02.05.464.00	02.05.464.00	---	---	---	---
11	Box Stop (Qty. 4)	04.29.073.00	04.29.073.00	04.29.073.00	04.29.073.00	---	---	---	---
12	Glass Bracket, Lower (Qty. 2)	04.29.017.00	04.29.017.00	04.29.017.00	04.29.017.00	---	---	---	---
13	Glass Bracket, LH Upper	04.29.018.00	04.29.018.00	04.29.018.00	04.29.018.00	---	---	---	---
14	Glass Bracket, RH Upper	04.29.019.00	04.29.019.00	04.29.019.00	04.29.019.00	---	---	---	---
15	Glass Panel (Qty. 2)	04.40.134.00	04.40.134.00	04.40.134.00	04.40.134.00	---	---	---	---
16	Support Post, Rear (Qty. 2)	04.29.123.00	04.29.123.00	04.29.123.00	04.29.123.00	---	---	---	---
17	Support Post, Front (Qty. 2)	04.29.125.00	04.29.125.00	04.29.125.00	04.29.125.00	---	---	---	---
18	Post Cover, Rear (Qty. 2)	04.29.127.00	04.29.127.00	04.29.127.00	04.29.127.00	---	---	---	---
19	Post Cover, Front (Qty. 2)	04.29.129.00	04.29.129.00	04.29.129.00	04.29.129.00	---	---	---	---
	Electrical Diagram	HS2-5082	HS2-5082	HS2-5083	HS2-5083	---	---	---	---

Shaded area reflects export models only.

PARTS SPECIFIC TO MODEL GRPWS-4818Q

ITEM	DESCRIPTION	120V	120V Canada	120/208V	120/240V	220V	240V	220-230V CE	230-240V CE
6	Light Bulb (Qty. 16)	---	---	02.30.043.00	02.30.043.00	---	---	---	---
7	Cord & Plug	---	---	02.18.085.00	02.18.085.00	---	---	---	---
8	On/Off Switch (Qty. 4)	---	---	02.19.080.00	02.19.080.00	---	---	---	---
9	Heating Element, Front (Qty. 4)	---	---	02.05.460.00	02.05.460.00	---	---	---	---
10	Heating Element, Rear (Qty. 4)	---	---	02.05.461.00	02.05.461.00	---	---	---	---
11	Box Stop (Qty. 4)	---	---	04.29.028.00	04.29.028.00	---	---	---	---
12	Glass Bracket, Lower (Qty. 2)	---	---	04.29.017.00	04.29.017.00	---	---	---	---
13	Glass Bracket, LH Upper	---	---	04.29.018.00	04.29.018.00	---	---	---	---
14	Glass Bracket, RH Upper	---	---	04.29.019.00	04.29.019.00	---	---	---	---
15	Glass Panel (Qty. 2)	---	---	04.40.134.00	04.40.134.00	---	---	---	---
16	Support Post, Rear (Qty. 2)	---	---	04.29.123.00	04.29.123.00	---	---	---	---
17	Support Post, Front (Qty. 2)	---	---	04.29.125.00	04.29.125.00	---	---	---	---
18	Post Cover, Rear (Qty. 2)	---	---	04.29.127.00	04.29.127.00	---	---	---	---
19	Post Cover, Front (Qty. 2)	---	---	04.29.129.00	04.29.129.00	---	---	---	---
	Electrical Diagram	---	---	HS2-5083	HS2-5083	---	---	---	---

PARTS SPECIFIC TO MODEL GRPWS-2424Q

ITEM	DESCRIPTION	120V	120V Canada	120/208V	120/240V	220V	240V	220-230V CE	230-240V CE
6	Light Bulb (Qty. 16)	02.30.043.00	02.30.043.00	---	---	---	---	---	---
7	Cord & Plug	R02.18.083.00	R02.18.083.00	---	---	---	---	---	---
8	On/Off Switch (Qty. 4)	02.19.080.00	02.19.080.00	---	---	---	---	---	---
9	Heating Element, Front (Qty. 4)	02.05.468.00	02.05.468.00	---	---	---	---	---	---
10	Heating Element, Rear (Qty. 4)	02.05.475.00	02.05.475.00	---	---	---	---	---	---
11	Box Stop (Qty. 4)	04.29.028.00	04.29.028.00	---	---	---	---	---	---
12	Glass Bracket, Lower (Qty. 2)	04.29.017.00	04.29.017.00	---	---	---	---	---	---
13	Glass Bracket, LH Upper	04.29.018.00	04.29.018.00	---	---	---	---	---	---
14	Glass Bracket, RH Upper	04.29.019.00	04.29.019.00	---	---	---	---	---	---
15	Glass Panel (Qty. 2)	04.40.134.00	04.40.134.00	---	---	---	---	---	---
16	Support Post, Rear (Qty. 2)	04.29.132.00	04.29.132.00	---	---	---	---	---	---
17	Support Post, Front (Qty. 2)	04.29.125.00	04.29.125.00	---	---	---	---	---	---
18	Post Cover, Rear (Qty. 2)	04.29.135.00	04.29.135.00	---	---	---	---	---	---
19	Post Cover, Front (Qty. 2)	04.29.129.00	04.29.129.00	---	---	---	---	---	---
	Electrical Diagram	HS2-5082	HS2-5082	---	---	---	---	---	---

Shaded area reflects export models only.

PARTS SPECIFIC TO MODEL GRPWS-3624Q

ITEM	DESCRIPTION	120V	120V Canada	120/208V	120/240V	220V	240V	220-230V CE	230-240V CE
6	Light Bulb (Qty. 12)	---	---	02.30.043.00	02.30.043.00	---	---	---	---
7	Cord & Plug	---	---	02.18.085.00	02.18.085.00	---	---	---	---
8	On/Off Switch (Qty. 4)	---	---	02.19.080.00	02.19.080.00	---	---	---	---
9	Heating Element, Front (Qty. 4)	---	---	02.05.470.00	02.05.470.00	---	---	---	---
10	Heating Element, Rear (Qty. 4)	---	---	02.05.477.00	02.05.477.00	---	---	---	---
11	Box Stop (Qty. 4)	---	---	04.29.073.00	04.29.073.00	---	---	---	---
12	Glass Bracket, Lower (Qty. 2)	---	---	04.15.796.00	04.15.796.00	---	---	---	---
13	Glass Bracket, LH Upper	---	---	04.29.035.00	04.29.035.00	---	---	---	---
14	Glass Bracket, RH Upper	---	---	04.29.036.00	04.29.036.00	---	---	---	---
15	Glass Panel (Qty. 2)	---	---	04.40.137.00	04.40.137.00	---	---	---	---
16	Support Post, Rear (Qty. 2)	---	---	04.29.132.00	04.29.132.00	---	---	---	---
17	Support Post, Front (Qty. 2)	---	---	04.29.125.00	04.29.125.00	---	---	---	---
18	Post Cover, Rear (Qty. 2)	---	---	04.29.135.00	04.29.135.00	---	---	---	---
19	Post Cover, Front (Qty. 2)	---	---	04.29.129.00	04.29.129.00	---	---	---	---
	Electrical Diagram	---	---	HS2-5083	HS2-5083	---	---	---	---

PARTS SPECIFIC TO MODEL GRPWS-4824Q

ITEM	DESCRIPTION	120V	120V Canada	120/208V	120/240V	220V	240V	220-230CE	230-240V CE
6	Light Bulb (Qty. 16)	---	---	02.30.043.00	02.30.043.00	---	---	---	---
7	Cord & Plug	---	---	02.18.085.00	02.18.085.00	---	---	---	---
8	On/Off Switch (Qty. 4)	---	---	02.19.080.00	02.19.080.00	---	---	---	---
9	Heating Element, Front (Qty. 4)	---	---	02.05.460.00	02.05.460.00	---	---	---	---
10	Heating Element, Rear (Qty. 4)	---	---	02.05.474.00	02.05.474.00	---	---	---	---
11	Box Stop (Qty. 4)	---	---	04.29.028.00	04.09.028.00	---	---	---	---
12	Glass Bracket, Lower (Qty. 2)	---	---	04.15.796.00	04.15.796.00	---	---	---	---
13	Glass Bracket, LH Upper	---	---	04.29.035.00	04.29.035.00	---	---	---	---
14	Glass Bracket, RH Upper	---	---	04.29.036.00	04.29.036.00	---	---	---	---
15	Glass Panel (Qty. 2)	---	---	04.40.137.00	04.40.137.00	---	---	---	---
16	Support Post, Rear (Qty. 2)	---	---	04.29.132.00	04.29.132.00	---	---	---	---
17	Support Post, Front (Qty. 2)	---	---	04.29.125.00	04.29.125.00	---	---	---	---
18	Post Cover, Rear (Qty. 2)	---	---	04.29.135.00	04.29.135.00	---	---	---	---
19	Post Cover, Front (Qty. 2)	---	---	04.29.129.00	04.29.129.00	---	---	---	---
	Electrical Diagram	---	---	HS2-5083	HS2-5083	---	---	---	---

Shaded area reflects export models only.

NOTES

NOTES

HATCO AUTHORIZED PARTS DISTRIBUTORS

ALABAMA

Jones McLeod Appl. Svc.
Birmingham 205-251-0159

ARIZONA

Auth. Comm. Food Equip.
Phoenix 602-234-2443
Byassee Equipment Co.
Phoenix 602-252-0402

CALIFORNIA

Industrial Electric
Huntington Beach 714-379-7100
Chapman Appl. Service
San Diego 619-298-7106
P & D
S. San Francisco 650-635-1900

COLORADO

Hawkins Commercial Appliance
Englewood 303-781-5548

DELAWARE

Food Equipment Service
Wilmington 302-996-9363

FLORIDA

Whaley Foodservice Repair
Jacksonville 904-725-7800
Nass Service Co., Inc.
Orlando 407-425-2681
B.G.S.I.
Pompano Beach 954-971-0456
Comm. Appliance Service
Tampa 813-663-0313

GEORGIA

Southeastern Rest. Svc.
Norcross 770-446-6177

HAWAII

Burney's Comm. Service, Inc.
Honolulu 808-848-1466
Food Equip Parts & Service
Honolulu 808-847-4871

ILLINOIS

Parts Town
Lombard 708-865-7278
Eichenauer Elec. Service
Decatur 217-429-4229
Midwest Elec. Appl. Service
Elmhurst 630-279-8000
Cone's Repair Service
Moline 309-797-5323

INDIANA

GCS Service
Indianapolis 317-545-9655

IOWA

Electric Motor Service Co.
Davenport 319-323-1823

KENTUCKY

GCS Service
Louisville 502-367-1788

LOUISIANA

Chandlers Parts & Service
Baton Rouge 225-272-6620
Bana Comm. Parts, Inc.
Shreveport 318-631-6550

MARYLAND

Electric Motor Service
Baltimore 410-467-8080
GCS Service
Silver Spring 301-585-7550

MASSACHUSETTS

Ace Service Co., Inc.
Needham 781-449-4220

MICHIGAN

Commercial Kitchen Service
Bay City 517-893-4561
Bildons Appliance Service
Detroit 248-478-3320
Midwest Food Equip. Service
Grandville 616-261-2000

MINNESOTA

GCS Service
Minneapolis 612-546-4221

MISSOURI

GCS Service
Kansas City 816-920-5999
Commercial Kitchen Services
St. Louis 314-890-0700

Kaemmerlen Parts & Service
St. Louis 314-535-2222

NEBRASKA

Anderson Electric
Omaha 402-341-1414

NEVADA

Burney's Commercial
Las Vegas 702-736-0006
Hi. Tech Commercial Service
N. Las Vegas 702-649-4616

NEW JERSEY

Jay Hill Repair
Fairfield 973-575-9145
Service Plus
Flanders 973-691-6300

NEW YORK

Acme American Repairs, Inc.
Brooklyn 718-456-6544
Alpro Service Co.
Brooklyn 718-386-2515

NEW YORK (continued)

Appliance Installation
Buffalo 716-884-7425
Northern Parts Dist.
Plattsburgh 518-563-3200
J. B. Brady, Inc.
Syracuse 315-422-9271

NORTH CAROLINA

Authorized Appliance
Charlotte 704-377-4501

OHIO

Akron/Canton Comm. Svc. Inc.
Akron 330-753-6635
Certified Service Center
Cincinnati 513-772-6600
GCS Service
Columbus 614-476-3225

Electrical Appl. Repair Service
Independence 216-459-8700
E. A. Wichman Co.
Toledo 419-385-9121

OKLAHOMA

Hagar Rest. Service, Inc.
Oklahoma City 405-235-2184
Krueger, Inc.
Oklahoma City 405-528-8883

OREGON

Bressie Electric Co.
Portland 503-231-7171
Ron's Service, Inc.
Portland 503-624-0890

PENNSYLVANIA

Authorized Factory Service
Coraopolis 412-262-2330
FAST Comm. Appl. Service
Philadelphia 215-288-4800
GCS Service
Pittsburgh 412-787-1970
K & D Service Co.
Harrisburg 717-236-9039
Elmer Schultz Services
Philadelphia 215-627-5401
Electric Repair Co.
Reading 610-376-5444

RHODE ISLAND

Marshall Electric Co.
Providence 401-331-1163

SOUTH CAROLINA

Whaley Foodservice Repair
W. Columbia 803-791-4420

TENNESSEE

Camp Electric
Memphis 901-527-7543

TEXAS

Stove Parts Supply
Fort Worth 817-831-0381
Armstrong Repair Service
Houston 713-666-7100
Commercial Kitchen Repair Co.
San Antonio 210-735-2811
San Antonio Rest. Equip.
San Antonio 210-532-1660

UTAH

GCS Service
Salt Lake City 801-487-3653

VIRGINIA

Daubers
Norfolk 757-855-4097
Daubers
Springfield 703-866-3600

WASHINGTON

Restaurant Appl. Service
Seattle 206-524-8200

WISCONSIN

A.S.C., Inc.
Madison 608-246-3160
A.S.C., Inc.
Milwaukee 414-543-6460

CANADA

BRITISH COLUMBIA

Key Food Equipment Service
Vancouver 604-433-4484

ONTARIO

R.G. Henderson Ltd.
Toronto 416-422-5580
Choquette CKS
Ottawa 613-739-8458

QUÉBEC

Choquette CKS
Montreal 514-722-2000
Choquette CKS
Québec City 418-681-3944

HATCO CORPORATION

P.O. Box 340500, Milwaukee, WI 53234-0500 U.S.A.

(800) 558-0607 (414) 671-6350

Parts & Service Fax (800) 690-2966 Int'l. Fax (414) 671-3976

www.hatcocorp.com