



IMPORTANT NOTE:

Locate the Specification Label on unit to determine exact Model Name and electrical specifications. This information is needed to identify the correct replacement parts. See exploded view illustration(s) for Specification Label location.



Use of replacement parts other than those supplied by Hatco Corporation may result in damage to unit or injury to personnel and will void all warranties.

Glo-Ray[®]

Merchandising Display Warmers

GRSDS Series

<u>Model Name</u>	<u>Page</u>	<u>Model Name</u>	<u>Page</u>	<u>Model Name</u>	<u>Page</u>
GRSDS-24	2	GRSDS-24D	4	GRSDS-24T	6
GRSDS-30	2	GRSDS-30D	4	GRSDS-36T	6
GRSDS-36	2	GRSDS-36D	4		
GRSDS-41	2	GRSDS-41D	4		
GRSDS-52	2	GRSDS-52D	4		
GRSDS-60	2	GRSDS-60D	4		

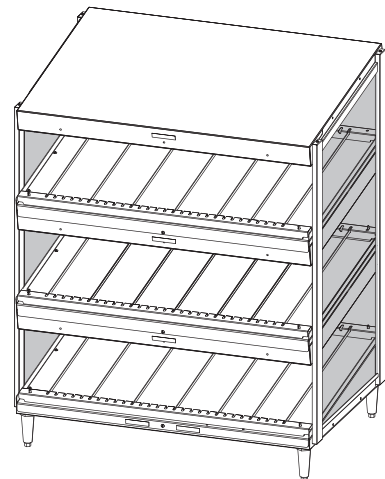
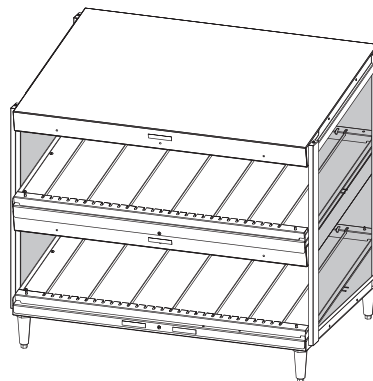
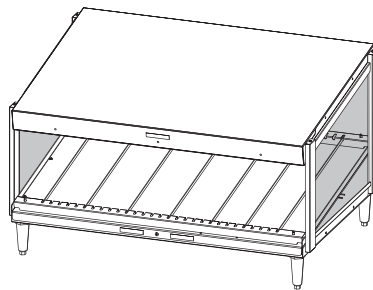

Replacement Parts List

Hatco Glo-Ray Merchandising Warmer

GRSDS — Single Shelf Models

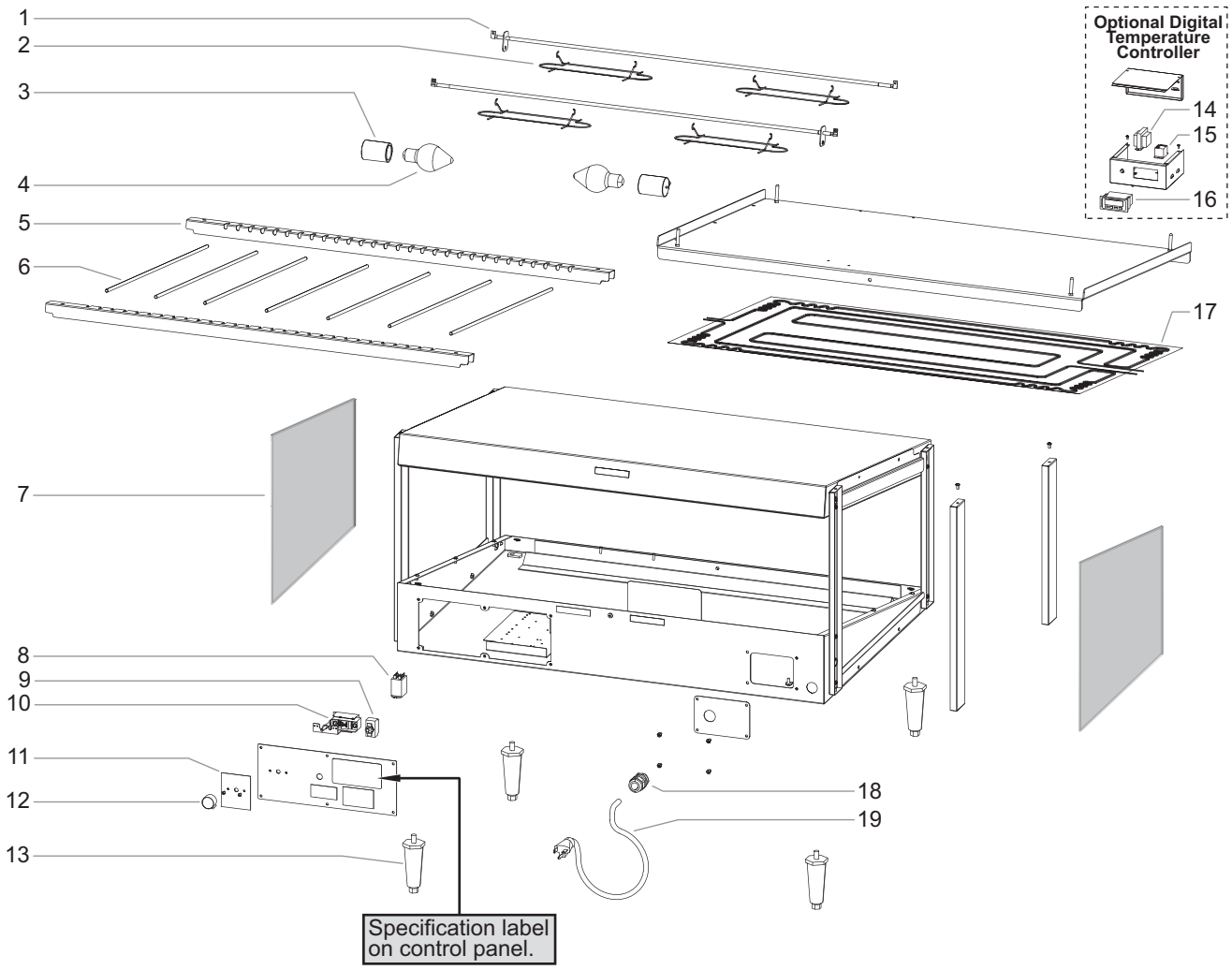

Item	Description	Part No.	Qty.
1	Calrod Element		
	24" Width, 120 V	R02.08.225D.00	2
	30" Width, 120 V	R02.08.222D.00	2
	36" Width, 120 V	R02.08.223D.00	2
	41" Width, 120 V	R02.08.224D.00	2
	52" Width, 120 V	R02.08.212D.00	2
	60" Width, 120 V	R02.08.262D.00	2
	24" Width, 220–230, 230–240 V	R02.08.225D.00	2
	30" Width, 220, 240, 220–230, 230–240 V	R02.08.232E.00	2
	36" Width, 220, 240, 220–230, 230–240 V	R02.08.228E.00	2
	41" Width, 220, 240, 220–230, 230–240 V	R02.08.229E.00	2
	52" Width, 220, 240, 220–230, 230–240 V	R02.08.230E.00	2
	60" Width, 220, 240, 220–230, 230–240 V	R02.08.264E.00	2

Item	Description	Part No.	Qty.
2	Wire Guard	04.37.145.00	2–8
3	Light Socket		
	24" Widths	02.30.045.00	1
	30" through 60" Widths	02.30.045.00	2–5
4	Light Bulb		
	120 V	02.30.043.00	2–5
	240 V	02.30.058.00	2–5
5	Divider Rods	04.15.112.00	5–12
6	Channel Divider		
	24" Width	04.15.054.00	2
	30" Width	04.15.753.00	2
	36" Width	04.15.754.00	2
	41" Width	04.15.755.00	2
	52" Width	04.15.756.00	2
	60" Width	04.15.075.00	2
7	Glass Side Panel	04.40.041.00	2

GRSDS — Single Shelf Models

Item	Description	Part No.	Qty.
8	Relay	02.01.088.00	1
9	On/Off Switch	02.19.008A.00	1
10	Thermostat, Base	02.16.002.00	1
11	Label, Thermostat	07.01.189.00	1
12	Knob, Thermostat	05.30.018.00	1
13	Leg, 4"	05.30.007.00	4
14	Transformer *		
	120 V	02.17.022.00	1
	220, 240 V	02.17.023.00	1
	220–230, 230–240 V	02.17.035.00	1
15	Relay *	R02.01.050.00	2
16	Digital Temperature Control *	R02.01.259.00	1
	Probe, Digital Temperature Control *	02.01.261.00	1
17	Blanket Heating Element		
	24" Width, 120 V	02.05.319.00	1
	30" Width, 120 V	02.05.213.00	1
	36" Width, 120 V	02.05.211.00	1
	41" Width, 120 V	02.05.209.00	1
	52" Width, 120 V	02.05.205.00	1
	60" Width, 120 V	02.05.287.00	1
	24" Width, 220–230, 230–240 V	02.05.100.00	3
		02.05.131.00	2
	30" Width, 220, 240, 220–230, 230–240 V	02.05.222.00	1
	36" Width, 220, 240, 220–230, 230–240 V	02.05.220.00	1
	41" Width, 220, 240, 220–230, 230–240 V	02.05.218.00	1
	52" Width, 220, 240, 220–230, 230–240 V	02.05.216.00	1
	60" Width, 220, 220–230 V	02.05.289.00	1
	60" Width, 240, 230–240 V	02.05.291.00	1
18	Cord Grip		
	120 V	02.20.330.00	1
	120 V (Canada)	02.20.440.00	1
	220, 240, 220–230, 230–240 V	R02.20.259.00	1
19	Power Cord and Plug		
	120 V, 24"–52" Width, NEMA 5-15P	R02.18.030.00	1
	120 V, 60" Width, NEMA 5-15P	R02.18.154.00	1
	120 V, 60" Width, NEMA 5-20P (Canada)	02.18.089.00	1
	240, 220–230, 230–240 V, 6 A, BS-1363	02.18.066.00	1
	240, 220–230, 230–240 V, 13 A, BS-1363	02.18.068.00	1
	240 V, AS 3112 (Australia)	02.18.104.00	1
	220, 220–230 V, CEE 7/7 Schuko	02.18.077.00	1

Item	Description	Part No.	Qty.
20	Flip-Up Doors (optional)		
	24" Width	SDS24FLIP	1
	30" Width	SDS30FLIP	1
	36" Width	SDS36FLIP	1
	41" Width	SDS41FLIP	1
	52" Width	SDS52FLIP	1
	60" Width	SDS60FLIP	1
	Wiring Diagram		
	Thermostat Control		
	120 V, 24"–60" Width	10-01-966	
	220, 240, 220–230, 230–240 V, 30"–60" Width	10-01-1299	
	220, 240 V, 24" Width	HS1-3689	
	220–230, 230–240 V, 24" Width	HS1-4139	
	Digital Temperature Control		
	120 V, 24"–60" Width	10-01-964	
	220, 240, 220–230, 230–240 V, 30"–60" Width	10-01-1298	
	220, 240 V, 24" Width	HS1-3687	
	220–230, 230–240 V, 24" Width	HS1-4146	

* For units with optional Digital Temperature Controller only.

NOTE: Quantities shown as a range (example = "2–4") are dependent upon the width of a unit.

The shaded areas contain information for **International models only.**

*NOTE: The last four digits in a ten digit numerical serial number are the manufacturing date code: 962506**1404***

Year 2014 ———┐
Week Four ———┘

HATCO GLO-RAY MERCHANDISING WARMER

GRSDS — Dual Shelf Models

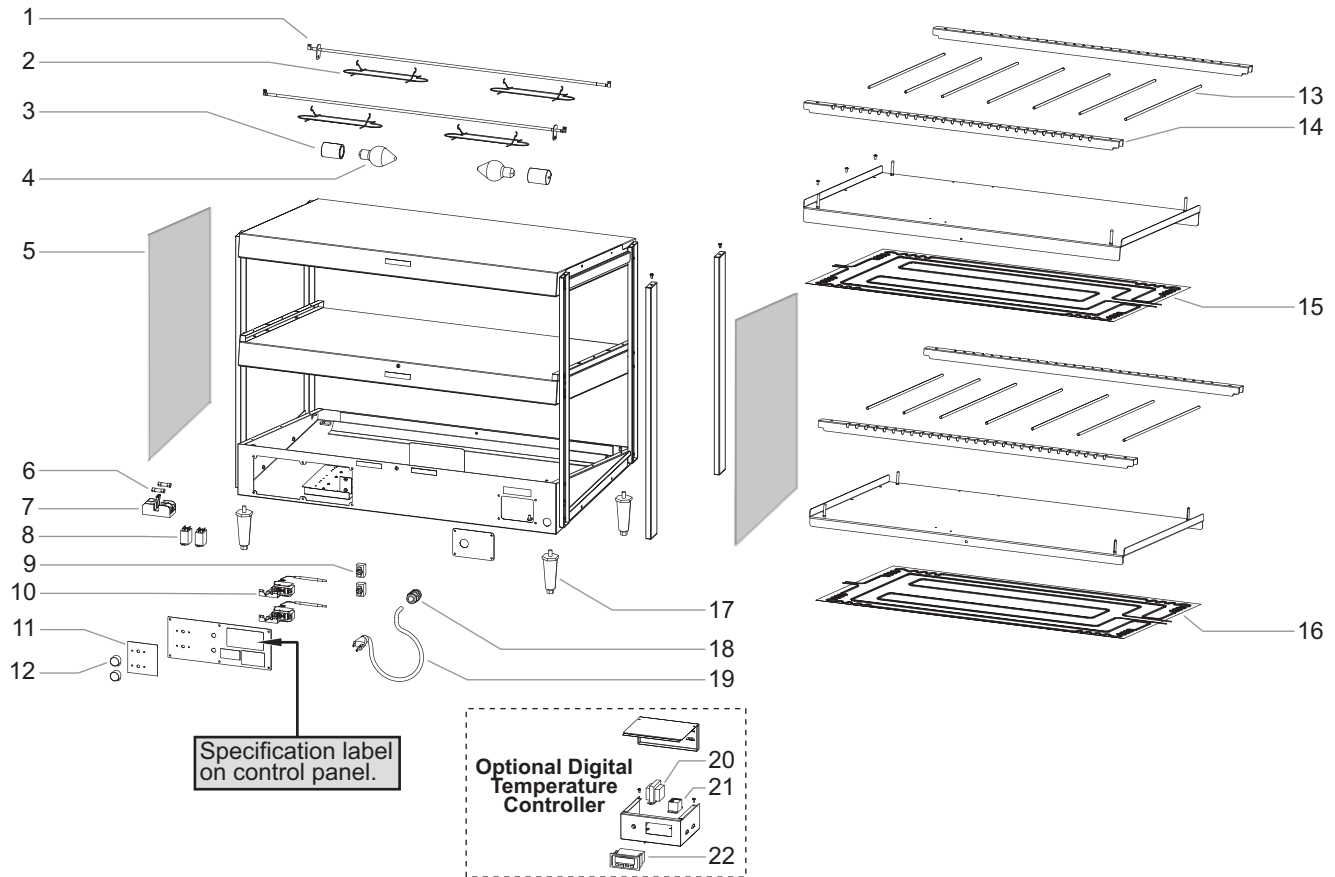

Item	Description	Part No.	Qty.
1	Calrod Element		
	24" Width, 120 V	R02.08.225D.00	4
	30" Width, 120 V	R02.08.222D.00	4
	36" Width, 120 V	R02.08.223D.00	4
	41" Width, 120, 120/208-240 V	R02.08.224D.00	4
	52" Width, 120, 120/208-240 V	R02.08.212D.00	4
	60" Width, 120/208-240 V	R02.08.262D.00	4
	24" Width, 220, 240, 220-230, 230-240 V	R02.08.225D.00	4
	30" Width, 220, 240, 220-230, 230-240 V	R02.08.232E.00	4
	36" Width, 220, 240, 220-230, 230-240 V	R02.08.228E.00	4
	41" Width, 220, 240, 220-230, 230-240 V	R02.08.229E.00	4
	52" Width, 220, 240, 220-230, 230-240 V	R02.08.230E.00	4
	60" Width, 220, 240, 220-230, 230-240 V	R02.08.264E.00	4

Item	Description	Part No.	Qty.
2	Wire Guard	04.37.145.00	4-16
3	Light Socket		
	24" Widths	02.30.045.00	2
	30" through 60" Widths	02.30.044.00	4-10
4	Light Bulb		
	120 V	02.30.043.00	4-10
	240 V	02.30.058.00	4-10
5	Glass Side Panel	04.40.038.00	2
6	Fuse (2 pack)	R02.03.052.02	2
7	Fuse Block	02.03.022.00	1
8	Relay	02.01.088.00	2
9	On/Off Switch	R02.19.016.00	2
10	Thermostat, Base	02.16.002.00	2
11	Label, Thermostat	07.01.190.00	1
12	Knob, Thermostat	05.30.018.00	2

GRSDS — Dual Shelf Models

Item	Description	Part No.	Qty.
13	Divider Rods	04.15.112.00	10–24
14	Channel Divider		
	24" Width	04.15.054.00	4
	30" Width	04.15.753.00	4
	36" Width	04.15.754.00	4
	41" Width	04.15.755.00	4
	52" Width	04.15.756.00	4
	60" Width	04.15.075.00	4
15	Blanket Heating Element, Center Shelf		
	24" Width, 120 V	02.05.320.00	1
	30" Width, 120 V	02.05.214.00	1
	36" Width, 120 V	02.05.212.00	1
	41" Width, 120, 120/208-240 V	02.05.209.00	1
	52" Width, 120, 120/208-240 V	02.05.205.00	1
	60" Width, 120/208-240 V	02.05.288.00	1
	24" Width, 220–240 V	02.05.100.00	3
		02.05.131.00	2
	30" Width, 220–240 V	02.05.223.00	1
	36" Width, 220–240 V	02.05.221.00	1
	41" Width, 220–240 V	02.05.219.00	1
	52" Width, 220–240 V	02.05.217.00	1
	60" Width, 220–240 V	02.05.292.00	1
16	Blanket Heating Element, Base		
	24" Width, 120 V	02.05.319.00	1
	30" Width, 120 V	02.05.213.00	1
	36" Width, 120 V	02.05.211.00	1
	41" Width, 120, 120/208-240 V	02.05.210.00	1
	52" Width, 120, 120/208-240 V	02.05.206.00	1
	60" Width, 120/208-240 V	02.05.287.00	1
	24" Width, 220–240 V	02.05.100.00	3
		02.05.131.00	2
	30" Width, 220–240 V	02.05.222.00	1
	36" Width, 220–240 V	02.05.220.00	1
	41" Width, 220–240 V	02.05.218.00	1
	52" Width, 220–240 V	02.05.216.00	1
	60" Width, 220–240 V	02.05.291.00	1
17	Leg, 4"	05.30.007.00	4
18	Cord Grip		
	120 V	02.20.330.00	1–2
	120/208-240 V	R02.20.259.00	1
	220, 240, 220–230, 230–240 V	R02.20.259.00	1
	230–240 V	02.20.440.00	1
19	Power Cord and Plug		
	120 V, NEMA 5-15P	R02.18.030.00	1–2
	120 V, NEMA 5-20P	02.18.089.00	1
	120/208-240 V, NEMA 14-20P	02.18.085.00	1
	120/208-240 V, NEMA L14-20P	02.18.128.00	1
	220, 240, 220–230, 230–240 V, 13 A, BS-1363	02.18.068.00	1
	240 V, AS 3112 (Australia)	02.18.104.00	1
	220, 220–230 V, CEE 7/7 Schuko	02.18.077.00	1

Item	Description	Part No.	Qty.
20	Transformer *		
	120 V	02.17.022.00	2
	220, 240 V	02.17.023.00	2
	220–230, 230–240 V	02.17.035.00	2
21	Relay *	R02.01.050.00	4
22	Digital Temperature Control *	R02.01.259.00	2
	Probe, Digital Temperature Control *	02.01.261.00	2
23	Flip-Up Doors (optional)		
	24" Width	SDS24FLIP	1–2
	30" Width	SDS30FLIP	1–2
	36" Width	SDS36FLIP	1–2
	41" Width	SDS41FLIP	1–2
	52" Width	SDS52FLIP	1–2
	60" Width	SDS60FLIP	1–2
	Wiring Diagram		
	Thermostat Control		
	120 V, 24"–60" Width	10-01-974	
	220, 240, 220–230, 230–240 V, 30"–60" Width	10-01-1301	
	220, 240 V, 24" Width	HS2-2798	
	220–230, 230–240 V, 24" Width	HS2-3485	
	Digital Temperature Control		
	120 V, 24"–60" Width	10-01-973	
	220, 240, 220–230, 230–240 V, 30"–60" Width	10-01-1300	
	220, 240 V, 24" Width	HS2-2792	
	220–230, 230–240 V, 24" Width	HS2-3492	

* For units with optional Digital Temperature Controller only.

NOTE: Quantities shown as a range (example = "2–4") are dependent upon the width of a unit.

The shaded areas contain information for **International models only.**

*NOTE: The last four digits in a ten digit numerical serial number are the manufacturing date code: 962506**1404***

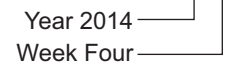

HATCO GLO-RAY MERCHANDISING WARMER

GRSDS — Triple Shelf Models

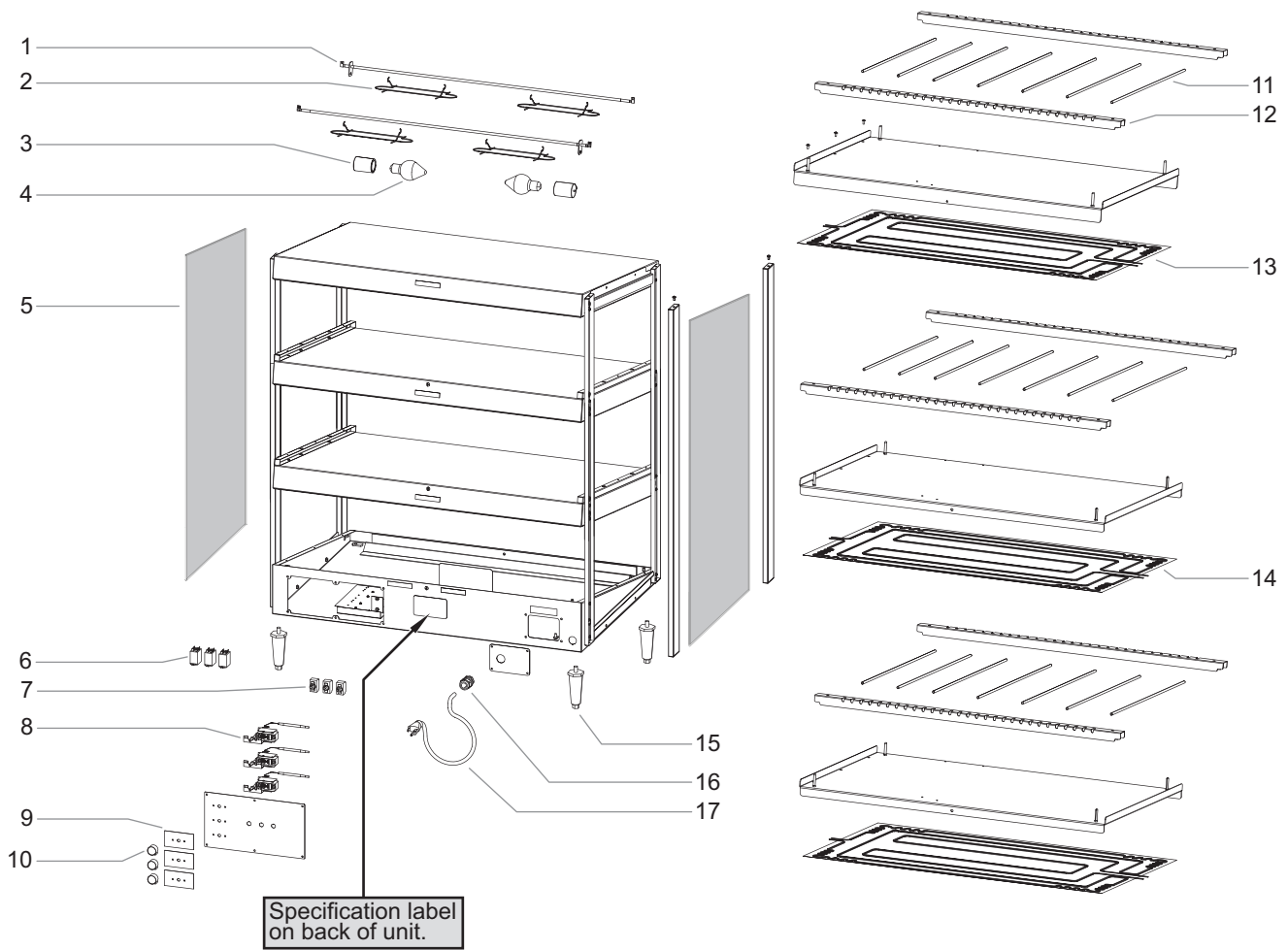

GRSDS — Triple Shelf Models

Item	Description	Part No.	Qty.
1	Calrod Element		
	24" Width, 120 V	R02.08.225D.00	6
	36" Width, 120/208-240 V	R02.08.223D.00	6
2	Wire Guard	04.37.145.00	6-12
3	Light Socket		
	24" Width	02.30.045.00	3
	36" Width	02.30.044.00	6
4	Light Bulb, 120 V	02.30.043.00	6
5	Glass Side Panel	04.40.109.00	2
6	Relay	02.01.236.00	3
7	On/Off Switch	R02.19.016.00	3
8	Thermostat, Base	R02.16.039.00	3
9	Label, Thermostat	07.03.134.00	3
10	Knob, Thermostat	05.30.039.00	3
11	Divider Rods	04.15.112.00	15-21
12	Channel Divider		
	24" Width	04.15.054.00	6
	36" Width	04.15.754.00	6
13	Blanket Heating Element, Center Shelves		
	24" Width, 120 V	02.05.320.00	2
	36" Width, 120/208-240 V	02.05.212.00	2
14	Blanket Heating Element, Base		
	24" Width, 120 V	02.05.319.00	1
	36" Width, 120/208-240 V	02.05.211.00	1

Item	Description	Part No.	Qty.
15	Leg, 4"	05.30.007.00	4
16	Cord Grip	R02.20.259.00	1
17	Power Cord and Plug		
	120 V, NEMA 5-20P	02.18.185.00	1
	120/208-240 V, NEMA L14-20P	02.18.128.00	1
18	Flip-Up Doors (optional)		
	24" Width	SDS24FLIP	3
	36" Width	SDS36FLIP	3
	Wiring Diagram		
	24" Width, 120 V	10-01-606	
	36" Width, 120/208-240 V	10-01-620	

*NOTE: The last four digits in a ten digit numerical serial number are the manufacturing date code: 962506**1404***

Year 2014 ————
 Week Four ————

NOTE: Quantities shown as a range (example = "2-4") are dependent upon the width of a unit.

AUTHORIZED PARTS DISTRIBUTORS • DISTRIBUTEURS DE PIÈCES AUTORISÉS

ALABAMA

Jones McLeod Appl. Svc.
Birmingham 205-251-0159

ARIZONA

Service Solutions Group
Phoenix 602-234-2443

Byassee Equipment Co.
Phoenix 602-252-0402

CALIFORNIA

Industrial Electric
Commercial Parts & Service, Inc.
Huntington Beach 714-379-7100

Chapman Appl. Service
San Diego 619-298-7106

P & D Appliance
Commercial Parts & Service, Inc.
S. San Francisco 650-635-1900

COLORADO

Hawkins Commercial Appliance
Englewood 303-781-5548

FLORIDA

Whaley Foodservice Repair
Jacksonville 904-725-7800

Whaley Foodservice Repair
Orlando 407-757-0851

B.G.S.I.
Pompano Beach 954-971-0456

Comm. Appliance Service
Tampa 813-663-0313

GEORGIA

TWC Services
Mableton 770-438-9797

Heritage Service Group
Norcross 866-388-9837

Southeastern Rest. Svc.
Norcross 770-446-6177

HAWAII

Burney's Comm. Service, Inc.
Honolulu 808-848-1466

Food Equip Parts & Service
Honolulu 808-847-4871

ILLINOIS

Parts Town
Lombard 708-865-7278

Eichenauer Elec. Service
Decatur 217-429-4229

Midwest Elec. Appl. Service
Elmhurst 630-279-8000

Cone's Repair Service
Moline 309-797-5323

INDIANA

GCS Service
Indianapolis 800-727-8710

IOWA

Goodwin Tucker Group
Des Moines 515-262-9308

KENTUCKY

Service Solutions Group
Lexington 859-254-8854

Service Solutions Group
Louisville 502-451-5411

LOUISIANA

Chandlers Parts & Service
Baton Rouge 225-272-6620

MARYLAND

Electric Motor Service
Baltimore 410-467-8080

GCS Service
Silver Spring 301-585-7550

MASSACHUSETTS

Ace Service Co., Inc.
Needham 781-449-4220

MICHIGAN

Bildons Appliance Service
Detroit 248-478-3320

Commercial Kitchen Service
Bay City 989-893-4561

Midwest Food Equip. Service
Grandville 616-261-2000

MINNESOTA

GCS Service
Minnetonka 800-822-2303
x20365

MISSOURI

General Parts
Kansas City 816-421-5400

Commercial Kitchen Services
St. Louis 314-890-0700

Kaemmerlen Parts & Service
St. Louis 314-535-2222

NEBRASKA

Anderson Electric
Omaha 402-341-1414

NEVADA

Burney's Commercial
Las Vegas 702-736-0006

Hi. Tech Commercial Service
N. Las Vegas 702-649-4616

NEW JERSEY

Jay Hill Repair
Fairfield 973-575-9145

Service Plus
Flanders 973-691-6300

NEW YORK

Acme American Repairs, Inc.
Jamaica 718-456-6544

Alpro Service Co.
Maspeth 718-386-2515

Appliance Installation
Buffalo 716-884-7425

Duffy's Equipment Services, Inc.
Buffalo 800-836-1014

3Wire Northern
Plattsburgh 800-634-5005

Duffy's Equipment Services, Inc.
Sauquoit 800-836-1014

J.B. Brady, Inc.
Syracuse 315-422-9271

NORTH CAROLINA

Authorized Appliance
Charlotte 704-377-4501

OHIO

Akron/Canton Comm. Svc. Inc.
Akron 330-753-6634

Service Solutions Group
Cincinnati 513-772-6600

Commercial Parts and Service
Columbus 614-221-0057

Electrical Appl. Repair Service
Brooklyn Heights 216-459-8700

E. A. Wichman Co.
Toledo 419-385-9121

OKLAHOMA

Hagar Rest. Service, Inc.
Oklahoma City 405-235-2184

Krueger, Inc.
Oklahoma City 405-528-8883

OREGON

Ron's Service, Inc.
Portland 503-624-0890

PENNSYLVANIA

Elmer Schultz Services
Philadelphia 215-627-5401

FAST Comm. Appl. Service
Philadelphia 215-288-4800

Appliance Installation & Service
Pittsburgh 412-809-0244

K & D Service Co.
Harrisburg 717-236-9039

Electric Repair Co.
Reading 610-376-5444

RHODE ISLAND

Marshall Electric Co.
Providence 401-331-1163

SOUTH CAROLINA

Whaley Foodservice Repair
Lexington 803-996-9900

TENNESSEE

Camp Electric
Memphis 901-527-7543

TEXAS

GCS Service
Fort Worth 800-433-1804

Armstrong Repair Service
Houston 713-666-7100

Cooking Equipment Specialist
Mesquite 972-686-6666

Commercial Kitchen Repair Co.
San Antonio 210-735-2811

UTAH

La Monica's Rest. Equip. Service
Murray 801-263-3221

VIRGINIA

Daubers
Norfolk 757-855-4097

Daubers
Springfield 703-866-3600

WASHINGTON

3Wire Restaurant Appliance
Seattle 800-207-3146

WISCONSIN

A.S.C., Inc.
Madison 608-246-3160

A.S.C., Inc.
Milwaukee 414-543-6460

CANADA

ALBERTA

Key Food Equipment Service
Edmonton 780-438-1690

BRITISH COLUMBIA

Key Food Equipment Service
Vancouver 604-433-4484

Key Food Equipment Service
Victoria 250-920-4888

MANITOBA

Air Rite, Inc.
Winnipeg 204-895-2300

NEW BRUNSWICK

EMR Services, Ltd.
Moncton 506-855-4228

ONTARIO

R.G. Henderson Ltd.
Toronto 416-422-5580

Choquette - CKS, Inc.
Ottawa 613-739-8458

QUÉBEC

Choquette - CKS, Inc.
Montreal 514-722-2000

Choquette - CKS, Inc.
Québec City 418-681-3944

UNITED KINGDOM

Marren Group
Northants +44(0)1933 665313

HATCO CORPORATION

P.O. Box 340500

Milwaukee, WI 53234-0500 U.S.A.

800-558-0607 414-671-6350

partsandservice@hatcocorp.com

www.hatcocorp.com



24 Hour 7 Day Parts and Service
Assistance available in the United States
and Canada by calling 800-558-0607.