



Register Online!
(see page 2)



Narrow Display Light NLL Series

Installation and Operating Manual

P/N 07.04.575.00

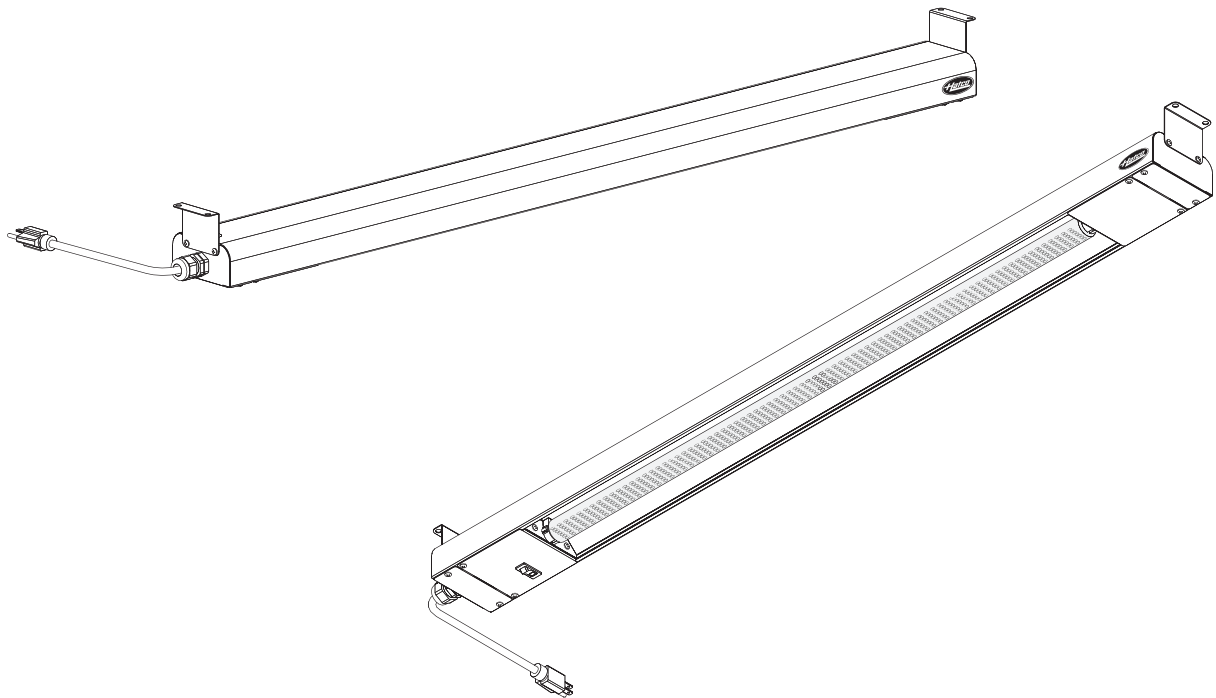

⚠ WARNING

Do not operate this equipment unless you have read and understood the contents of this manual! Failure to follow the instructions contained in this manual may result in serious injury or death. This manual contains important safety information concerning the maintenance, use, and operation of this product. If you're unable to understand the contents of this manual, please bring it to the attention of your supervisor. Keep this manual in a safe location for future reference.

⚠ ADVERTENCIA

No opere este equipo al menos que haya leído y comprendido el contenido de este manual! Cualquier falla en el seguimiento de las instrucciones contenidas en este manual puede resultar en un serio lesión o muerte. Este manual contiene importante información sobre seguridad concerniente al mantenimiento, uso y operación de este producto. Si usted no puede entender el contenido de este manual por favor pregunte a su supervisor. Almacenar este manual en una localización segura para la referencia futura.

⚠ AVERTISSEMENT

Ne pas utiliser cet équipement sans avoir lu et compris le contenu de ce manuel ! Le non-respect des instructions contenues dans ce manuel peut entraîner de graves blessures ou la mort. Ce manuel contient des informations importantes concernant l'entretien, l'utilisation et le fonctionnement de ce produit. Si vous ne comprenez pas le contenu de ce manuel, veuillez le signaler à votre supérieur. Conservez ce manuel dans un endroit sûr pour pouvoir vous y référer plus tard.

CONTENTS

Important Owner Information	2	Operation	5
Introduction	2	General	5
Important Safety Information	3	Maintenance	6
Model Designation	3	General	6
Model Description	4	Cleaning	6
Specifications	4	Replacing an LED Light Tube	6
Plug Configuration.....	4	Troubleshooting Guide	7
Electrical Rating Chart	4	Limited Warranty	7
Dimensions	4	Authorized Parts Distributors	Back Cover
Installation	5		
General	5		
Installing the Unit.....	5		

IMPORTANT OWNER INFORMATION

Record the model number, serial number, voltage, and purchase date of the unit in the spaces below (specification label located on the side of the unit). Please have this information available when calling Hatco for service assistance.

Model No. _____

Serial No. _____

Voltage _____

Date of Purchase _____

Register your unit!

Completing online warranty registration will prevent delay in obtaining warranty coverage. Access the Hatco website at www.hatcocorp.com, select the *Parts & Service* pull-down menu, and click on "Warranty Registration".

Business Hours: 8:00 AM to 5:00 PM
Central Standard Time (C.S.T.)
(Summer Hours: June to September –
8:00 AM to 5:00 PM C.S.T.
Monday through Thursday
8:00 AM to 2:30 PM C.S.T. Friday)

Telephone: (800) 558-0607; (414) 671-6350

E-mail: partsandservice@hatcocorp.com

Fax: (800) 690-2966 (Parts and Service)
(414) 671-3976 (International)



24 Hour 7 Day Parts and Service
Assistance available in the United States
and Canada by calling (800) 558-0607.

Additional information can be found by visiting our web site at www.hatcocorp.com.

INTRODUCTION

Hatco NLL Series Narrow Display Lights provide effective and stylish lighting for non-critical food holding and display areas. The narrow housing of the NLL Series is ideal for installation in tight spaces.

NLL Series Narrow Display Lights are products of extensive research and field testing. The materials used were selected for maximum durability, attractive appearance, and optimum performance. Every unit is inspected and tested thoroughly prior to shipment.

This manual provides the installation, safety, and operating instructions for NLL Series Narrow Display Lights. Hatco recommends all installation, operating, and safety instructions appearing in this manual be read prior to installation or operation of a unit.

Safety information that appears in this manual is identified by the following signal word panels:



WARNING indicates a hazardous situation which, if not avoided, could result in death or serious injury.



CAUTION indicates a hazardous situation which, if not avoided, could result in minor or moderate injury.



NOTICE is used to address practices not related to personal injury.

IMPORTANT SAFETY INFORMATION



Read the following important safety information before using this equipment to avoid serious injury or death and to avoid damage to equipment or property.

⚠ WARNING

ELECTRIC SHOCK HAZARD:

- Plug unit into a properly grounded electrical receptacle of the correct voltage, size, and plug configuration. If plug and receptacle do not match, contact a qualified electrician to determine and install proper voltage and size electrical receptacle.
- Turn OFF power switch, unplug power cord, and allow unit to cool before performing any cleaning, adjustments, or maintenance.
- DO NOT submerge or saturate with water. Unit is not waterproof. Do not operate if unit has been submerged or saturated with water.
- Unit is not weatherproof. Locate unit indoors where the ambient air temperature is a minimum of 70°F (21°C).
- Do not install unit above a steam table or other steam generating appliance.
- Do not steam clean or use excessive water on the unit.
- This unit is not “jet-proof” construction. Do not use jet-clean spray to clean this unit.
- Do not clean unit when it is energized or hot.
- Discontinue use if power cord is frayed or worn.
- Do not attempt to repair or replace a damaged power cord. Cord must be replaced by Hatco, an Authorized Hatco Service Agent, or a person with similar qualifications.
- Use only Genuine Hatco Replacement Parts when service is required. Failure to use Genuine Hatco Replacement Parts will void all warranties and may subject operators of the equipment to hazardous electrical voltage, resulting in electrical shock or burn. Genuine Hatco Replacement Parts are specified to operate safely in the environments in which they are used. Some aftermarket or generic replacement parts do not have the characteristics that will allow them to operate safely in Hatco equipment.

⚠ WARNING

Make sure all operators have been instructed on the safe and proper use of the unit.

This unit is not intended for use by children or persons with reduced physical, sensory, or mental capabilities. Ensure proper supervision of children and keep them away from the unit.

Use only Hatco-approved LED light tubes that are specifically designed for food holding areas. Using LED light tubes not designed for food holding areas could result in personal injury and/or food contamination.

This unit must be serviced by qualified personnel only. Service by unqualified personnel may lead to electric shock or burn.

This unit has no “user-serviceable” parts. If service is required on this unit, contact an Authorized Hatco Service Agent or contact the Hatco Service Department at 800-558-0607 or 414-671-6350; fax 800-690-2966; or International fax 414-671-3976.

⚠ CAUTION

Do not install unit on or below a radiant-heating ceiling.

NOTICE

Use non-abrasive cleaners and cloths only. Abrasive cleaners and cloths could scratch finish of unit, marring its appearance and making it susceptible to soil accumulation.

Make sure to install LED light tube in proper orientation to prevent damage to light tube. Refer to MAINTENANCE section for details.

This unit is intended for commercial use only — NOT for household use.

MODEL DESIGNATION

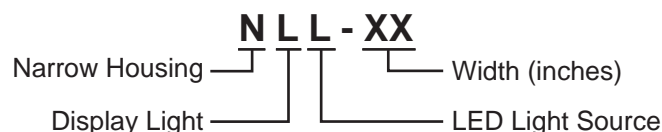

Figure 1. Model Designation

MODEL DESCRIPTION

NLL Series Narrow Display Lights consist of a narrow-style steel housing that is ideal for installation in tight spaces. They are equipped with LED (light-emitting diode) light tubes that provide bright display lighting to bring focus on the product below. Controls consist of an illuminated Power On/Off switch located on the underside of the unit on one end. A 6' (1829 mm) power cord with plug is installed on the unit. Finish options include stainless steel, several powdercoated colors, gloss finishes, and plated finishes.

NLL Series Narrow Display Lights are available in widths from 30" (762 mm) to 60" (1524 mm) in six inch increments. They are supplied with mounting brackets for under-shelf mounting.

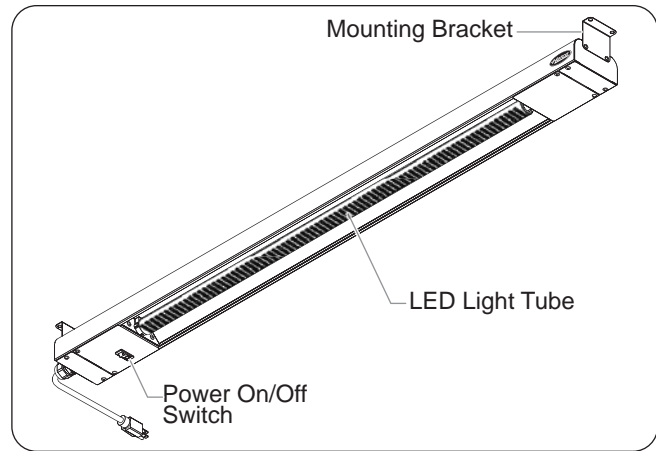

Figure 2. NLL-48 Model

SPECIFICATIONS

Plug Configuration

Units are supplied from the factory with a power cord and plug installed.



ELECTRIC SHOCK HAZARD: Plug unit into a properly grounded electrical receptacle of the correct voltage, size, and plug configuration. If plug and receptacle do not match, contact a qualified electrician to determine and install proper voltage and size electrical receptacle.

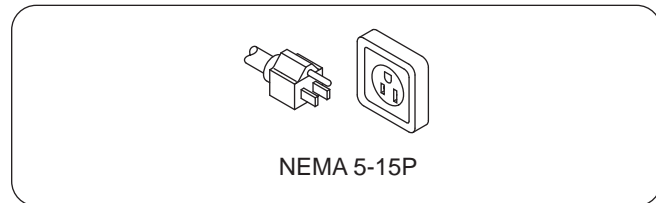

Figure 3. Plug Configuration

NOTE: Receptacle not supplied by Hatco.

Electrical Rating Chart

Model	Volts	Watts	Amps	Plug Configuration	Shipping Weight
NLL-30	120	10	0.08	NEMA 5-15P	12 lbs. (5 kg)
NLL-36	120	10	0.08	NEMA 5-15P	13 lbs. (6 kg)
NLL-42	120	14	0.12	NEMA 5-15P	14 lbs. (6 kg)
NLL-48	120	14	0.12	NEMA 5-15P	15 lbs. (7 kg)
NLL-54	120	20	0.17	NEMA 5-15P	17 lbs. (8 kg)
NLL-60	120	20	0.17	NEMA 5-15P	18 lbs. (8 kg)

NOTE : Specification label located on the side of the unit. See label for serial number and verification of unit electrical information.

Dimensions

Model	Width (A)	Depth (B)	Height (C)
NLL-XX	30–60" (762–1524 mm)	4" (102 mm)	2" (51 mm)

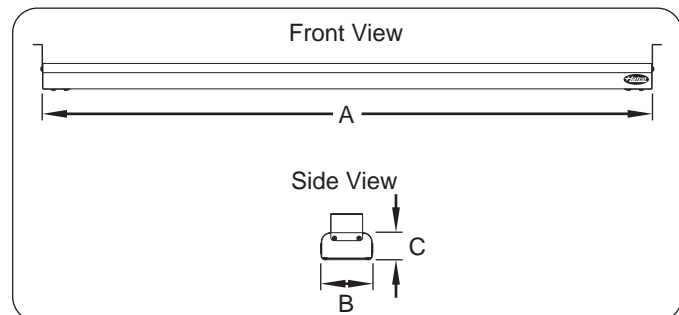

Figure 4. Dimensions

General

Use the information in this section to install a NLL Series Narrow Display Light.

⚠ WARNING

ELECTRIC SHOCK HAZARD:

- Unit is not weatherproof. Locate unit indoors where the ambient air temperature is a minimum of 70°F (21°C).
- Do not install unit above a steam table or other steam generating appliance.

1. Remove the unit from the carton.

NOTE: To prevent delay in obtaining warranty coverage, complete online warranty registration. See the IMPORTANT OWNER INFORMATION section for details.

2. Remove tape and protective packaging from all surfaces of the unit.
3. Install the unit in the desired location. Refer to the “Installing the Unit” procedure in this section.

NOTE: LED display lights cannot be installed over a steam table.

Installing the Unit

Use the following procedure to install the unit using the supplied mounting brackets.

⚠ CAUTION

Do not install unit on or below a radiant-heating ceiling.

1. Attach the included mounting brackets to each end of the unit using the screws provided.
2. Fasten the mounting brackets on each end of the unit to the underside of a shelf or other overhead mounting surface using appropriate fasteners (not supplied by Hatco).
 - Make sure the unit is facing the desired direction with the power cord on the proper side before fastening the unit to the overhead surface.

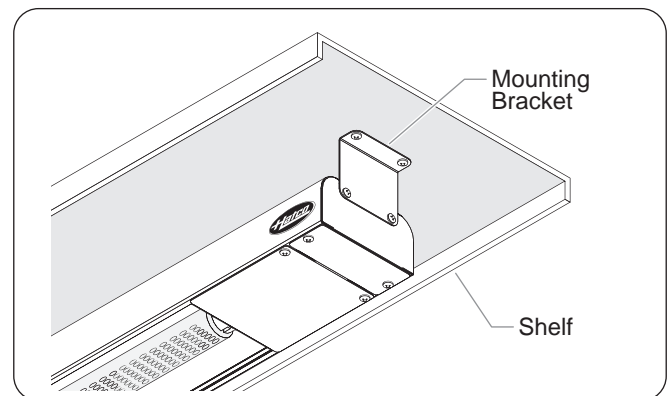

Figure 5. Under-Shelf Installation

3. Plug the unit into an appropriate electrical receptacle.

OPERATION

General

Use the following information to operate a NLL Series Narrow Display Light.

⚠ WARNING

Read all safety messages in the IMPORTANT SAFETY INFORMATION SECTION before operating this equipment.

Startup

1. Move the Power On/Off switch to the “On” position. The LED light tube will illuminate.

Shutdown

1. Move the Power On/Off switch to the “Off” position.
2. Perform the “Daily Cleaning” procedure in the MAINTENANCE section of this manual.

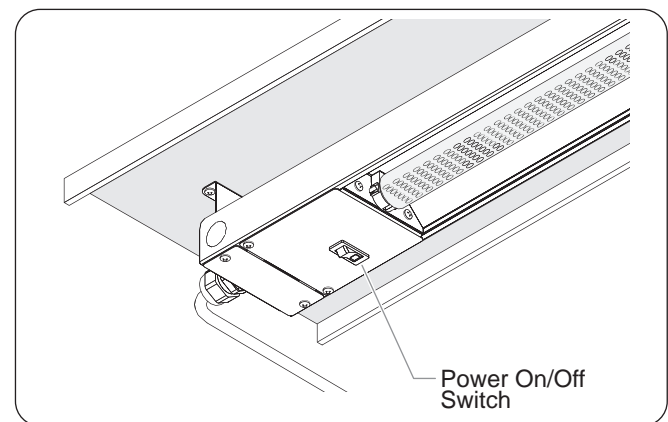

Figure 6. NLL Series Power On/Off Switch

MAINTENANCE

General

NLL Series Narrow Display Lights are designed for maximum durability and performance with minimum maintenance.

⚠ WARNING

ELECTRIC SHOCK HAZARD:

- Turn OFF power switch, unplug power cord, and allow unit to cool before performing any cleaning, adjustments, or maintenance.
- **DO NOT submerge or saturate with water. Unit is not waterproof. Do not operate if unit has been submerged or saturated with water.**
- Do not steam clean or use excessive water on the unit.
- This unit is not “jet-proof” construction. Do not use jet-clean spray to clean this unit.
- Do not clean unit when it is energized or hot.
- Use only Genuine Hatco Replacement Parts when service is required. Failure to use Genuine Hatco Replacement Parts will void all warranties and may subject operators of the equipment to hazardous electrical voltage, resulting in electrical shock or burn. Genuine Hatco Replacement Parts are specified to operate safely in the environments in which they are used. Some aftermarket or generic replacement parts do not have the characteristics that will allow them to operate safely in Hatco equipment.

This unit has no “user-serviceable” parts. If service is required on this unit, contact an Authorized Hatco Service Agent or contact the Hatco Service Department at 800-558-0607 or 414-671-6350; fax 800-690-2966; or International fax 414-671-3976.

Cleaning

To preserve the finish of the unit as well as maintain performance, it is recommended that the unit be cleaned daily.

NOTICE

Use non-abrasive cleaners and cloths only. Abrasive cleaners and cloths could scratch finish of unit, marring its appearance and making it susceptible to soil accumulation.

1. Turn off the unit, unplug the power cord, and allow the unit to cool.
2. Wipe down all metal surfaces using a non-abrasive, damp cloth. Stubborn stains may be removed with a non-abrasive cleaner. Hard to reach areas should be cleaned with a small brush and mild soap.
3. Wipe dry the entire unit using a non-abrasive, dry cloth.

Replacing an LED Light Tube

Use the following procedure to replace an LED light tube.

⚠ WARNING

Use only Hatco-approved LED light tubes that are specifically designed for food holding areas. Using LED light tubes not designed for food holding areas could result in personal injury and/or food contamination.

1. Turn off the unit, unplug the power cord, and allow the unit to cool.
2. Carefully twist the old LED light tube and pull down to remove it from the sockets on each end.

NOTICE

Make sure to install LED light tube in proper orientation to prevent damage to light tube.

3. Locate the new LED light tube and orient the tube so the end with the “LIVE END” marking corresponds with the yellow “LIVE END” label on the unit.
3. Align the tabs on each end of the new LED light tube with the channels on each socket, and push the tube up into the sockets.
4. Carefully twist the LED light tube in the sockets until it “snaps” into position with the LED lights pointing down.

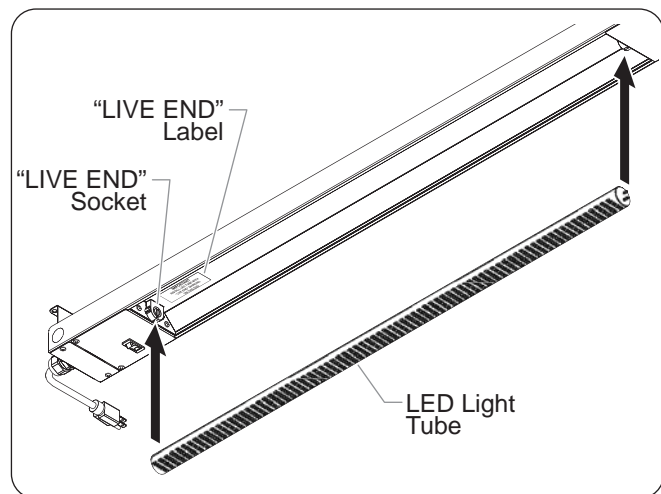

Figure 7. Replacing an LED Light Tube

The following replacement LED light tubes are available from Hatco:

24" LED Light Tube = P/N 02.30.153.00, 10 W
(Models NLL-30 and NLL-36)

36" LED Light Tube = P/N 02.30.154.00, 14 W
(Models NLL-42 and NLL-48)

48" LED Light Tube = P/N 02.30.143.00, 20 W
(Models NLL-54 and NLL-60)

TROUBLESHOOTING GUIDE



WARNING

This unit must be serviced by qualified personnel only. Service by unqualified personnel may lead to electric shock or burn.



WARNING

ELECTRIC SHOCK HAZARD: Turn OFF power switch, unplug power cord, and allow unit to cool before performing any cleaning, adjustments, or maintenance.

Symptom	Probable Cause	Corrective Action
Unit is turned on, but not working.	Circuit breaker tripped.	Reset circuit breaker.
	LED light tube burned out.	Replace LED light tube. Refer to procedure in MAINTENANCE section.
	Power On/Off switch defective.	Contact Authorized Service Agent or Hatco for assistance.
	Supply voltage to unit is incorrect.	Verify the supply voltage to the unit matches the unit specifications.
	Internal electrical malfunction.	Contact Authorized Service Agent or Hatco for assistance.
Light is inadequate.	LED light tube partially burned out.	Replace LED light tube. Refer to procedure in MAINTENANCE section.
	Unit mounted too high above target area.	Lower unit, putting effective light closer to target.
	Supply voltage to unit is incorrect.	Verify the supply voltage to the unit matches the unit specifications.

LIMITED WARRANTY

1. PRODUCT WARRANTY

Hatco warrants the products that it manufactures (the "Products") to be free from defects in materials and workmanship, under normal use and service, for a period of one (1) year from the date of purchase when installed and maintained in accordance with Hatco's written instructions or 18 months from the date of shipment from Hatco. Buyer must establish the Product's purchase date by registering the Product with Hatco or by other means satisfactory to Hatco in its sole discretion.

Hatco warrants the following Product components to be free from defects in materials and workmanship from the date of purchase (subject to the foregoing conditions) for the period(s) of time and on the conditions listed below:

- a) **One (1) Year Parts and Labor PLUS One (1) Additional Year Parts-Only Warranty:**
 Conveyor Toaster Elements (metal sheathed)
 Drawer Warmer Elements (metal sheathed)
 Drawer Warmer Drawer Rollers and Slides
 Strip Heater Elements (metal sheathed)
 Display Warmer Elements (metal sheathed air heating)
 Holding Cabinet Elements (metal sheathed air heating)
 Heated Well Elements — HWB Series (metal sheathed)
- b) **One (1) Year Parts and Labor PLUS Four (4) Years Parts-Only Warranty on pro-rated terms that Hatco will explain at Buyer's request:**
 3CS and FR Tanks
- c) **One (1) Year Parts and Labor PLUS Nine (9) Years Parts-Only Warranty on:**
 Electric Booster Heater Tanks
 Gas Booster Heater Tanks
- d) **Ninety (90) Day Parts-Only Warranty:**
 Replacement Parts

THE FOREGOING WARRANTIES ARE EXCLUSIVE AND IN LIEU OF ANY OTHER WARRANTY, EXPRESSED OR IMPLIED, INCLUDING BUT NOT LIMITED TO ANY IMPLIED WARRANTY OF MERCHANTABILITY OR FITNESS FOR A PARTICULAR PURPOSE OR PATENT OR OTHER INTELLECTUAL PROPERTY RIGHT INFRINGEMENT. Without limiting the generality of the foregoing, SUCH WARRANTIES DO NOT COVER: Coated incandescent light bulbs, fluorescent lights, heat lamp bulbs, coated halogen light bulbs, halogen heat lamp bulbs, xenon light bulbs, LED light tubes, glass components, and fuses; Product failure in booster tank, fin tube heat exchanger, or other water heating equipment caused by liming, sediment buildup, chemical attack, or freezing; or Product misuse, tampering or misapplication, improper installation, or application of improper voltage.

2. LIMITATION OF REMEDIES AND DAMAGES

Hatco's liability and Buyer's exclusive remedy hereunder will be limited solely, at Hatco's option, to repair or replacement using new or refurbished parts or Product by Hatco or a Hatco-authorized service agency (other than where Buyer is located outside of the United States, Canada, United Kingdom, or Australia, in which case Hatco's liability and Buyer's exclusive remedy hereunder will be limited solely to replacement of part under warranty) with respect to any claim made within the applicable warranty period referred to above. Hatco reserves the right to accept or reject any such claim in whole or in part. In the context of this Limited Warranty, "refurbished" means a part or Product that has been returned to its original specifications by Hatco or a Hatco-authorized service agency. Hatco will not accept the return of any Product without prior written approval from Hatco, and all such approved returns shall be made at Buyer's sole expense. HATCO WILL NOT BE LIABLE, UNDER ANY CIRCUMSTANCES, FOR CONSEQUENTIAL OR INCIDENTAL DAMAGES, INCLUDING BUT NOT LIMITED TO LABOR COSTS OR LOST PROFITS RESULTING FROM THE USE OF OR INABILITY TO USE THE PRODUCTS OR FROM THE PRODUCTS BEING INCORPORATED IN OR BECOMING A COMPONENT OF ANY OTHER PRODUCT OR GOODS.

HATCO AUTHORIZED PARTS DISTRIBUTORS

ALABAMA

Jones McLeod Appl. Svc.
Birmingham 205-251-0159

ARIZONA

Service Solutions Group
Phoenix 602-234-2443

Byassee Equipment Co.
Phoenix 602-252-0402

CALIFORNIA

Industrial Electric
Commercial Parts & Service, Inc.
Huntington Beach 714-379-7100

Chapman Appl. Service
San Diego 619-298-7106

P & D Appliance
Commercial Parts & Service, Inc.
S. San Francisco 650-635-1900

COLORADO

Hawkins Commercial Appliance
Englewood 303-781-5548

FLORIDA

Whaley Foodservice Repair
Jacksonville 904-725-7800

3Wire Nass Service Co., Inc.
Orlando 407-425-2681

B.G.S.I.
Pompano Beach 954-971-0456

Comm. Appliance Service
Tampa 813-663-0313

GEORGIA

TWC Services
Mableton 770-438-9797

Heritage Service Group
Norcross 866-388-9837

Southeastern Rest. Svc.
Norcross 770-446-6177

HAWAII

Burney's Comm. Service, Inc.
Honolulu 808-848-1466

Food Equip Parts & Service
Honolulu 808-847-4871

ILLINOIS

Parts Town
Lombard 708-865-7278

Eichenauer Elec. Service
Decatur 217-429-4229

Midwest Elec. Appl. Service
Elmhurst 630-279-8000

Cone's Repair Service
Moline 309-797-5323

INDIANA

GCS Service
Indianapolis 317-545-9655

IOWA

Electric Motor Service Co.
Davenport 319-323-1823

Goodwin Tucker Group
Des Moines 515-262-9308

KENTUCKY

Service Solutions Group
Lexington 859-254-8854

Service Solutions Group
Louisville 502-451-5411

LOUISIANA

Chandlers Parts & Service
Baton Rouge 225-272-6620

MARYLAND

Electric Motor Service
Baltimore 410-467-8080

GCS Service
Silver Spring 301-585-7550

MASSACHUSETTS

Ace Service Co., Inc.
Needham 781-449-4220

MICHIGAN

Bildons Appliance Service
Detroit 248-478-3320

Commercial Kitchen Service
Bay City 517-893-4561

Midwest Food Equip. Service
Grandville 616-261-2000

MINNESOTA

GCS Service
Plymouth 800-345-4221

MISSOURI

General Parts
Kansas City 816-421-5400

Commercial Kitchen Services
St. Louis 314-890-0700

Kaemmerlen Parts & Service
St. Louis 314-535-2222

NEBRASKA

Anderson Electric
Omaha 402-341-1414

NEVADA

Burney's Commercial
Las Vegas 702-736-0006

Hi. Tech Commercial Service
N. Las Vegas 702-649-4616

NEW JERSEY

Jay Hill Repair
Fairfield 973-575-9145

Service Plus
Flanders 973-691-6300

NEW YORK

Acme American Repairs, Inc.
Brooklyn 718-456-6544

Alpro Service Co.
Brooklyn 718-386-2515

Appliance Installation
Buffalo 716-884-7425

Duffy's Equipment Services, Inc.
Buffalo 800-836-1014

3Wire Northern
Plattsburgh 800-634-5005

Duffy's Equipment Services, Inc.
Sauquoit 800-836-1014

J.B. Brady, Inc.
Syracuse 315-422-9271

NORTH CAROLINA

Authorized Appliance
Charlotte 704-377-4501

OHIO

Akron/Canton Comm. Svc. Inc.
Akron 330-753-6635

Service Solutions Group
Cincinnati 513-772-6600

Commercial Parts and Service
Columbus 614-221-0057

Electrical Appl. Repair Service
Brooklyn Heights 216-459-8700

E. A. Wichman Co.
Toledo 419-385-9121

OKLAHOMA

Hagar Rest. Service, Inc.
Oklahoma City 405-235-2184

Krueger, Inc.
Oklahoma City 405-528-8883

OREGON

Ron's Service, Inc.
Portland 503-624-0890

PENNSYLVANIA

Elmer Schultz Services
Philadelphia 215-627-5401

FAST Comm. Appl. Service
Philadelphia 215-288-4800

Appliance Installation & Service
Pittsburgh 412-809-0244

K & D Service Co.
Harrisburg 717-236-9039

Electric Repair Co.
Reading 610-376-5444

RHODE ISLAND

Marshall Electric Co.
Providence 401-331-1163

SOUTH CAROLINA

Whaley Foodservice Repair
W. Columbia 803-791-4420

TENNESSEE

Camp Electric
Memphis 901-527-7543

TEXAS

GCS Service
Fort Worth 800-433-1804

Armstrong Repair Service
Houston 713-666-7100

Cooking Equipment Specialist
Mesquite 888-866-9276

Refrigerated Specialist, Inc.
Mesquite 888-866-9276

Commercial Kitchen Repair Co.
San Antonio 210-735-2811

UTAH

La Monica's Rest. Equip. Service
Murray 801-263-3221

VIRGINIA

Daubers
Norfolk 757-855-4097

Daubers
Springfield 703-866-3600

WASHINGTON

3Wire Restaurant Appliance
Seattle 800-207-3146

WISCONSIN

A.S.C., Inc.
Madison 608-246-3160

A.S.C., Inc.
Milwaukee 414-543-6460

CANADA

ALBERTA

Key Food Equipment Service
Edmonton 780-438-1690

BRITISH COLUMBIA

Key Food Equipment Service
Vancouver 604-433-4484

Key Food Equipment Service
Victoria 250-920-4888

MANITOBA

Air Rite, Inc.
Winnipeg 204-895-2300

NEW BRUNSWICK

EMR Services, Ltd.
Moncton 506-855-4228

ONTARIO

R.G. Henderson Ltd.
Toronto 416-422-5580

Choquette - CKS, Inc.
Ottawa 613-739-8458

QUÉBEC

Choquette - CKS, Inc.
Montreal 514-722-2000

Choquette - CKS, Inc.
Québec City 418-681-3944

UNITED KINGDOM

Marren Group
Northants +44(0)1933 666233

HATCO CORPORATION

P.O. Box 340500

Milwaukee, WI 53234-0500 U.S.A.

(800) 558-0607 (414) 671-6350

Parts and Service Fax (800) 690-2966

International Fax (414) 671-3976

partsandservice@hatcocorp.com

www.hatcocorp.com

Register your unit online!

See IMPORTANT OWNER INFORMATION
section for details.