



# THERMO-FINISHER™

Food Finisher

TF 2000 Series

---

## Installation & Operating Manual

I & W #07.05.110.00

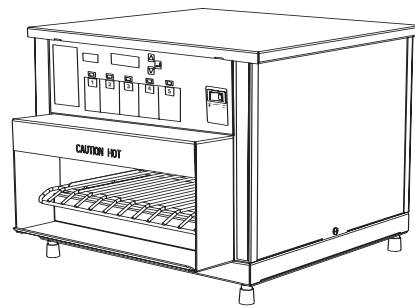
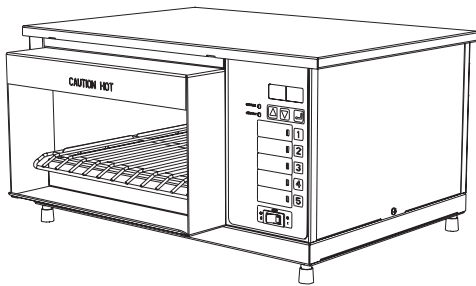

This manual contains important safety information concerning the maintenance, use and operation of this product. Failure to follow the instructions contained in this manual may result in serious injury. If you're unable to understand the contents of this manual, please bring it to the attention of your supervisor. Do not operate this equipment unless you have read and understood the contents of this manual.

Este manual contiene importante información sobre seguridad concerniente al mantenimiento, uso y operación de este producto. Cualquier falla en el seguimiento de las instrucciones contenidas en este manual puede resultar en un serio daño. Si usted no puede entender el contenido de este manual por favor pregunte a su supervisor. No opere este equipo al menos que haya leído y comprendido el contenido de este manual.

# CONTENTS

---

<b>Important Owner Information</b> .....	i	<b>Programming The Unit</b> .....	7
<b>Introduction</b> .....	i	General.....	7
<b>Important Safety Instructions</b> .....	1	<b>Programming Controller</b> .....	8
<b>Model Descriptions</b> .....	3	Programming a Selection.....	8
All Models.....	3	Idle Mode.....	10
TF-2005.....	3	Auto-Off Mode.....	10
TF-2010.....	3	Programming Hints.....	10
TF-2015.....	3	<b>Operation</b> .....	12
TF-2020.....	3	Basic Food Finishing.....	12
TF-2030.....	3	Food Finishing Hints.....	12
TF-2040.....	3	<b>Maintenance</b> .....	13
TF-2045.....	3	General.....	13
<b>Specifications</b> .....	4	Cleaning–Exterior.....	13
Plug Configurations.....	4	Blower Motors.....	13
Electrical Rating Chart.....	4	Cleaning–Interior.....	13
Dimensions.....	5	<b>Recommended Food Finishing Guide</b> .....	14
<b>Installation</b> .....	6	<b>Hatco Limited Warranty</b> .....	16
Unpacking.....	6	<b>Authorized Parts Distributors</b> .....	Back Cover
Location.....	6		

## IMPORTANT OWNER INFORMATION

---

Record the model number, serial number (located on the back or side of the unit), voltage and purchase date of your Thermo-Finisher™ Food Finisher in the spaces below. Please have this information available when calling Hatco for service assistance.

Model No. \_\_\_\_\_

Serial No. \_\_\_\_\_

Voltage \_\_\_\_\_

Date of Purchase \_\_\_\_\_

Business Hours: 8:00 a.m. to 5:00 p.m.  
Central Standard Time

(Summer Hours: June to September –  
8:00 a.m. to 5:00 p.m. C.D.T.  
Monday through Thursday  
8:00 a.m. to 2:30 p.m. C.D.T. Friday)

Telephone: (800) 558-0607; (414) 671-6350

Fax: (800) 690-2966 (Parts & Service)  
(414) 671-3976 (International)



Additional information can be found by visiting our web site at [www.hatcocorp.com](http://www.hatcocorp.com)

## INTRODUCTION

---

The Hatco Thermo-Finisher is designed to rapidly heat or thermalize a range of food products which allows operators to serve customers faster, thereby improving customer satisfaction. The Thermo-Finisher is perfect for melting toppings or finishing soup and foods like Mexican entrees, nachos and potato skins. It also thermalizes frozen foods such as appetizers, french fries and pizza. Thermo-Finisher can also be used to heat plates prior to serving.

This manual provides the installation, safety and operating instructions for the Thermo-Finisher Food Finisher. We recommend all installation, operating and safety instructions appearing in this manual be read prior to installation or operation of your Hatco Food

Finisher. Safety instructions that appear in this manual after a warning symbol  and the words **WARNING** or **CAUTION** printed in bold face are very important.  **WARNING** means there is the possibility of serious personal injury or death to yourself or others.  **CAUTION** means there is the possibility of minor or moderate injury. **CAUTION** *without the symbol* signifies the possibility of equipment or property damage only.

Your Hatco Thermo-Finisher Food Finisher is a product of extensive research and field testing. The materials used were selected for maximum durability, attractive appearance and optimum performance. Every unit is thoroughly inspected and tested prior to shipment.

# IMPORTANT SAFETY INSTRUCTIONS

**IMPORTANT! Read the following important safety instructions to avoid personal injury or death, and to avoid damage to the equipment or property.**

## ⚠ WARNINGS

- ⚠ Plug unit into a properly grounded electrical outlet of the correct voltage, size and plug configuration. If the plug and receptacle do not match, contact a qualified electrician to determine the proper voltage and size and install the proper electrical outlet.
- ⚠ To avoid any injury or damage to the unit do not pull unit by power cord.
- ⚠ To prevent any injury, discontinue use if power cord is frayed or worn.
- ⚠ For safe and proper operation, the unit must be located a reasonable distance from combustible walls and materials. If safe distances are not maintained, discoloration or combustion could occur. Do not locate unit under shelving or closer than 12" (305 mm) from the ceiling.
- ⚠ Allow a minimum of 1" (25 mm) clearance along the sides. Allow a clearance of 26" (660 mm) along the front and rear discharge (if equipped) to ensure proper operation and safety.
- ⚠ Model TF-2030 is designed for "pass-through" use only. To avoid burning or charring of materials, adequate clearance must be maintained from front and back openings. Do not install any closer than 26" (660 mm) from either opening.
- ⚠ To avoid any injury, turn the power switch OFF, unplug the unit from the power source and allow to cool before performing any maintenance.
- ⚠ Unit is not waterproof. DO NOT submerge in water. Do not operate if it has been submerged in water. Do not steam clean the interior or flood with water or liquid solution.
- ⚠ To avoid electrical shock or personal injury, do not steam clean or use excessive water on the unit.
- ⚠ If service is required on this unit, contact your Authorized Hatco Service Agent, or contact the Hatco Service Department at 800-558-0607 or 414-671-6350; fax 800-690-2966 or International fax 414-671-3976.

## ⚠ CAUTIONS

- ⚠ Unit is not weatherproof. For safe and proper operation locate the unit indoors where the ambient air temperature is a minimum of 70°F (21°C).
- ⚠ To avoid any injury or damage to the unit do not operate appliance without installation of supplied legs.
- ⚠ Some exterior surfaces on the unit will get hot. Use caution when touching these areas to avoid injury.
- ⚠ DO NOT use "Pyrex" glass plates or serving pieces in the finisher. "Pyrex" glass may break causing personal injury and/or food contamination.
- ⚠ Plate/tray will be very hot upon removal; use oven mitt, protective clothing, or pan gripper to remove.
- ⚠ Do not remove the glass from the unit for cleaning purposes. Doing so may cause injury or damage to the unit.
- ⚠ To avoid any injury or damage locate the unit at the proper counter height, in an area that is convenient for use. The location should be level to prevent the unit or its contents from accidentally falling, and strong enough to support the weight of the unit and food.
- ⚠ Do not place anything on top of the unit: doing so could damage the unit or subject personnel to injury.
- ⚠ DO NOT use paper or plastic serving pieces in the finisher. These materials may melt or burn causing a fire hazard and/or food contamination and may damage the unit.

# IMPORTANT SAFETY INSTRUCTIONS

---

**IMPORTANT! Read the following important safety instructions to avoid personal injury or death, and to avoid damage to the equipment or property.**

## **⚠ WARNINGS**

- ⚠ This product has no “user” serviceable parts. To avoid damage to the unit or injury to personnel, use only Authorized Hatco Service Agents and Genuine Hatco Replacement Parts when service is required.**
- ⚠ Genuine Hatco Replacement Parts are specified to operate safely in the environments in which they are used. Some aftermarket or generic replacement parts do not have the characteristics that will allow them to operate safely in Hatco equipment. It is essential to use Hatco Replacement Parts when repairing Hatco equipment. Failure to use Hatco Replacement Parts may subject operators of the equipment to hazardous electrical voltage, resulting in electrical shock or burn.**

## **CAUTIONS**

- Do not place any objects on the metal rack during preheat. Doing so will most likely over-cook the product.**
- Use only non-abrasive cleaners. Abrasive cleaners could scratch the finish of your Thermo-Finisher, marring its appearance and making it susceptible to dirt accumulation.**

# MODEL DESCRIPTIONS

## ALL MODELS

The Thermo-Finisher™ Food Finisher models have an easy-to-clean interior constructed of stainless steel and heavy-duty glass. The units feature quick-heating infrared ribbon elements with a microprocessor to control the temperature and heating time. All models come with a user-friendly control panel which accepts up to five preprogrammed recipe times. A plate rack and attached cord and plug set are included.

## MODEL TF-2005

The TF-2005 model features two upper elements and a removable broiler pan for heating food product. Loading and unloading of food is done on the control side of the unit.

## MODEL TF-2010

The TF-2010 model features two upper elements for heating food product on a plate. Loading and unloading of food is done on the control side of the unit.

## MODEL TF-2015

The TF-2015 model features two upper and two lower elements for heating food product on a plate. Loading and unloading of food is done on the control side of the unit.

## MODEL TF-2020

The TF-2020 model features one upper element to heat the food product on the plate and one lower element to heat the center of the plate. Loading and unloading of food is done on the control side of the unit.

## MODEL TF-2030

The TF-2030 model features one upper element to heat the food product on the plate and one lower element to heat the center of the plate. Because this model is a pass-through unit, loading and unloading of food product can be done on either side of the unit.

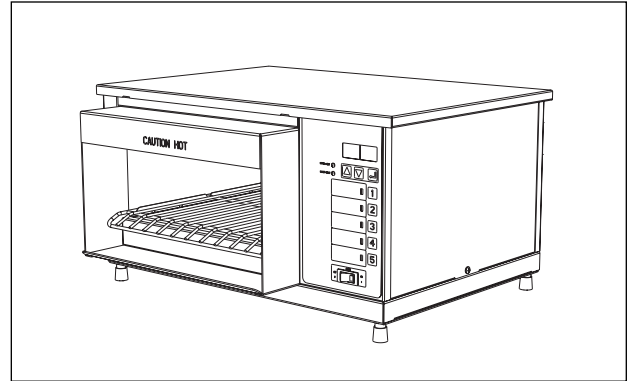

Figure 1. Thermo-Finisher Model TF-2020

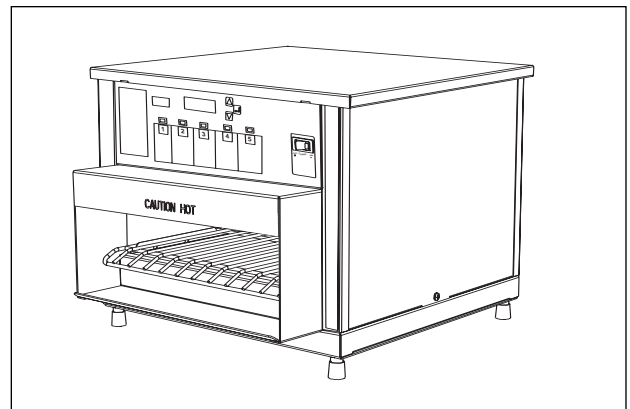

Figure 2. Thermo-Finisher Model TF-2040

## MODEL TF-2040

The TF-2040 model features four upper elements that heat food product on the plate and one lower element that heats the center of the plate. Loading and unloading of food product is done on the control side of the unit. (This unit requires three-phase power.)

## MODEL TF-2045

The TF-2045 model features four upper heating elements for heating food product on a plate. Loading and unloading of food is done on the control side of the unit.

# SPECIFICATIONS

## PLUG CONFIGURATIONS

Units are supplied from the factory with an electrical cord and plug on the back of the unit. See Figure 3.

**⚠ WARNING**

**Plug unit into a properly grounded electrical outlet of the correct voltage, size and plug configuration. If the plug and receptacle do not match, contact a qualified electrician to determine the proper voltage and size and install the proper electrical outlet.**

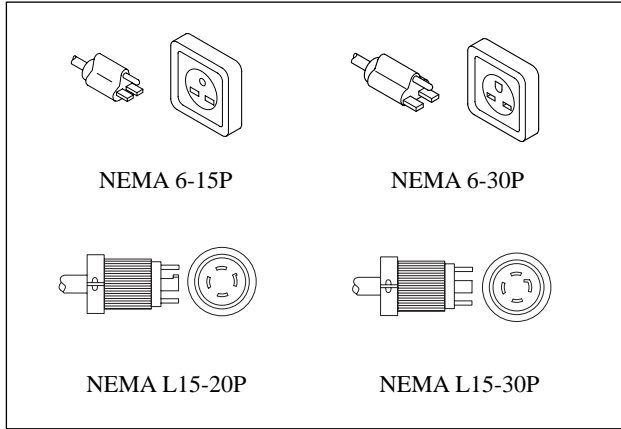

Figure 3. Plug Configurations

## ELECTRICAL RATING CHART

Model	Voltage	Watts	Amps	Phase	Plug Configuration	Shipping Weight
TF-2005	208	2400	11.5	1	NEMA 6-15P	55 lbs. (25 kg)
	220	2017	9.0	1	NONE	55 lbs. (25 kg)
	230	2204	9.5	1	NONE	55 lbs. (25 kg)
	240	2400	10.0	1	NEMA 6-15P	55 lbs. (25 kg)
TF-2010	208	2400	12.0	1	NEMA 6-15P	60 lbs. (27 kg)
	240	2400	10.0	1	NEMA 6-15P	60 lbs. (27 kg)
TF-2015	208	4800	23.0	1	NEMA 6-30P	60 lbs. (27 kg)
	240	4800	20.0	1	NEMA 6-30P	60 lbs. (27 kg)
TF-2020	208	4800	23.0	1	NEMA 6-30P	65 lbs. (30 kg)
	240	5000	21.0	1	NEMA 6-30P	65 lbs. (30 kg)
TF-2030	208	4800	23.0	1	NEMA 6-30P	65 lbs. (30 kg)
	240	5000	21.0	1	NEMA 6-30P	65 lbs. (30 kg)
TF-2040	208	7200	21.0	3	NEMA L15-30P	70 lbs. (32 kg)
	240	7300	18.0	3	NEMA L15-20P*	70 lbs. (32 kg)
TF-2045	208	4800	23.0	1	NEMA 6-30P	70 lbs. (32 kg)
	240	4800	20.0	1	NEMA 6-30P	70 lbs. (32 kg)

\* NEMA L15-30P for Canada.

The electrical information in the shaded areas pertains to **Export models only**.

# SPECIFICATIONS

## DIMENSIONS

### EXTERIOR DIMENSIONS

Model	(A) Width	(B) Depth	(C) Height*
TF-2005	14" (356 mm)	19-1/2"†◆ (495 mm)	9" (229 mm)
TF-2010	15-1/4" (387 mm)	21-3/4" (553 mm)	10-7/8" (276 mm)
TF-2015	15-1/4" (387 mm)	21-3/4" (553 mm)	10-7/8" (276 mm)
TF-2020	19-3/8" (492 mm)	21-1/8" (537 mm)	10-7/8" (276 mm)
TF-2030	19-3/8" (492 mm)	22-7/8" (581 mm)	10-7/8" (276 mm)
TF-2040	16-1/2" (419 mm)	26-1/8" (664 mm)	14" (356 mm)
TF-2045	16-1/2" (419 mm)	27-1/8" (689 mm)	14" (356 mm)

### INTERIOR CAVITY DIMENSIONS

Model	(D) Width	(E) Depth	(F) Height
TF-2005	6-3/4" (172 mm)	13-5/8" (346 mm)	3-1/4" (83 mm)
TF-2010	8-1/8" (206 mm)	14-3/4" (375 mm)	3-3/4" (95 mm)
TF-2015	8-1/8" (206 mm)	14-3/4" (375 mm)	3-3/4" (95 mm)
TF-2020	12-1/8" (308 mm)	12" (305 mm)	3-3/4" (95 mm)
TF-2030	12-1/8" (308 mm)	13-1/8" (333 mm)	3-3/4" (95 mm)
TF-2040	13-1/8" (333 mm)	18" (457 mm)	3-3/8" (86 mm)
TF-2045	13-1/8" (333 mm)	18" (457 mm)	5-3/8" (137 mm)

\* Includes metal foot with rubber cover attached.

† Allow an additional 1" (25 mm) minimum for power cord.

◆ Allow an additional 8" (203 mm) minimum for broiler pan.

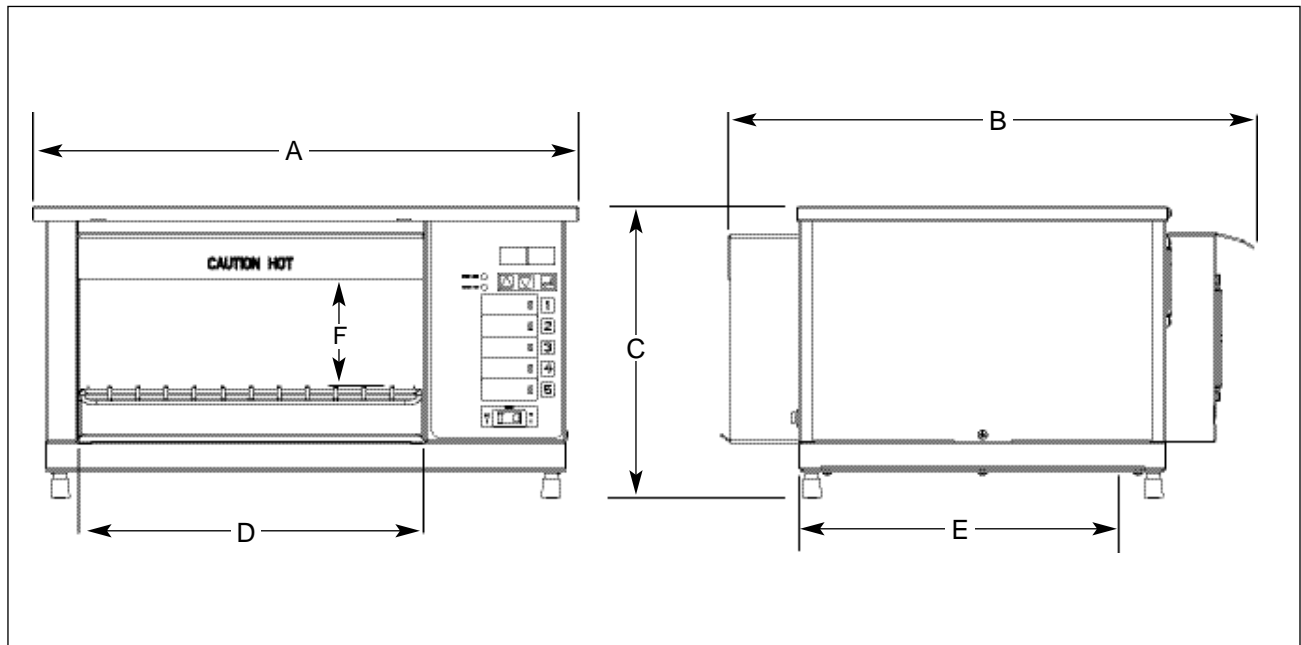

Figure 4. Dimensions

# INSTALLATION

## UNPACKING

1. Remove unit from box.
2. To prevent delay in obtaining warranty coverage, fill out and mail in warranty card.
3. Remove tape and protective packaging from all surfaces of unit.
4. Place wire plate rack on top of rack supports, making sure plate rack is not in direct contact with glass base. (See Figure 5.)

## LOCATION

### ⚠ WARNING

To avoid any injury or damage to the unit do not pull unit by power cord.

### ⚠ WARNING

To prevent any injury, discontinue use if power cord is frayed or worn.

### ⚠ WARNING

For safe and proper operation, the unit must be located a reasonable distance from combustible walls and materials. If safe distances are not maintained, discoloration or combustion could occur. Do not locate unit under shelving or closer than 12" (305 mm) from the ceiling.

### ⚠ WARNING

Allow a minimum of 1" (25 mm) clearance along the sides. Allow a clearance of 26" (660 mm) along the front and rear discharge (if equipped) to ensure proper operation and safety.

### ⚠ WARNING

Model TF-2030 is designed for "pass-through" use only. To avoid burning or charring of materials, adequate clearance must be maintained from front and back openings. Do not install any closer than 26" (660 mm) from either opening.

### ⚠ CAUTION

Unit is not weatherproof. For safe and proper operation locate the unit indoors where the ambient air temperature is a minimum of 70°F (21°C).

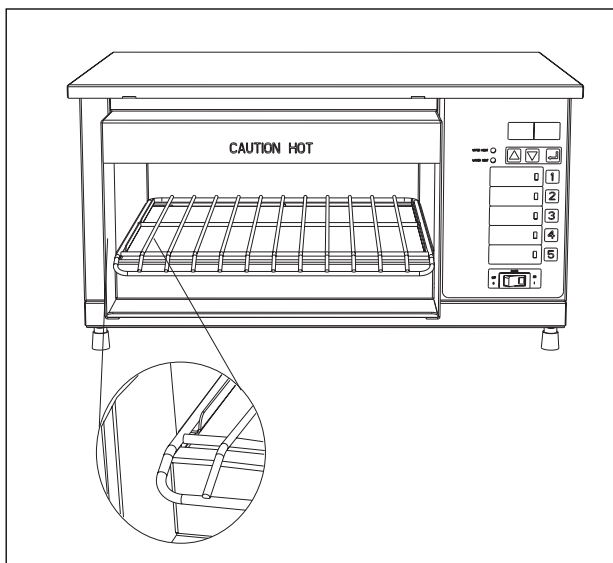

Figure 5. Rack Support Placement

### ⚠ CAUTION

To avoid any injury or damage locate the unit at the proper counter height, in an area that is convenient for use. The location should be level to prevent the unit or its contents from accidentally falling, and strong enough to support the weight of the unit and food.

### ⚠ CAUTION

Do not place anything on top of the unit; doing so could damage the unit or subject personnel to injury.



# PROGRAMMING THE UNIT

## GENERAL

Thermo-Finisher™ units (except TF-2005, TF-2010 and TF-2045) have both an upper and lower heating zone. The upper elements heat the product on the plate and the lower elements heat the center of the plate.

Five adjustable program button selections allow the operator to fine tune the radiant heat input and heating time for a variety of menu items. This adjustable feature assures optimum serving temperatures without effecting quality.

Thermo-Finisher units also feature an adjustable “Idle” mode and adjustable “Auto-Off” mode, which allow for additional flexibility.

***NOTE:** After reading and understanding how to program the unit, see Programming Hints and Recommended Food Finishing Guide in this manual for further helpful information.*

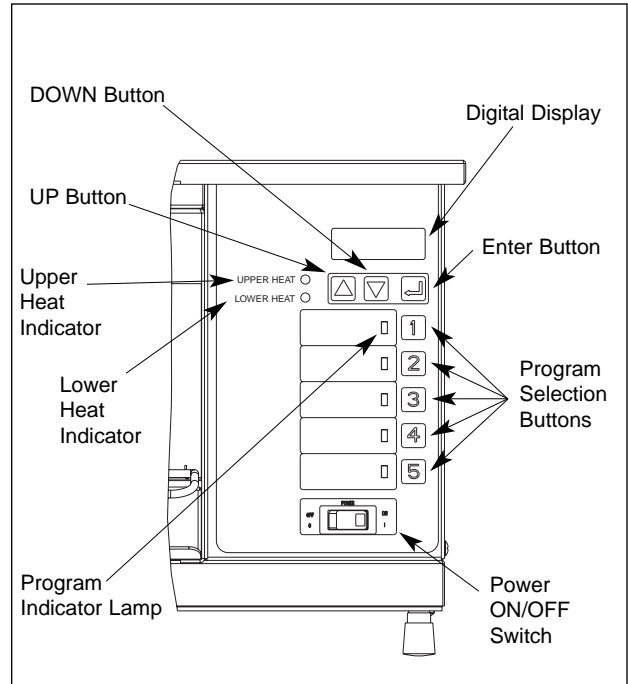

Figure 6. Control Panel

# PROGRAMMING CONTROLLER

---

## PROGRAMMING A SELECTION

The following terms are used when programming the unit:

**UP = Upper Power Value:** Controls the power setting on the upper heating element(s)

**UT = Upper Time Value:** Controls the time setting on the upper heating element(s)

**LP = Lower Power Value:** Controls the power setting on the lower heating element(s)



**LT = Lower Time Value:** Controls the time setting on the lower heating element(s)









When the unit display shows a Power Value (UP for upper heating zone or LP for lower heating zone) the number indicates the value set at a percentage: example P20 = 20%. These values are adjustable from 10-100% in 5% increments.

When the unit display shows a Time Value (UT for upper heating zone or LT for lower heating zone) the number indicates the time in seconds the heating element will be on example T35 = 35 seconds. These values are adjustable from 0-300 seconds.

1. Plug unit into a properly grounded electrical outlet of the correct voltage, size and plug configuration. (See *Specifications* for details.)
2. Turn power switch to the ON position. The unit will make an audible beep, automatically go into preheat and display will indicate 5783 (Figure 7A).

After the preheat cycle is complete the unit will display 8E33 (Figure 7B). The unit is now ready to be programmed.

3. With display showing 8E33, push and hold the desired numbered Program Selection button, while at the same time push and hold the Enter  button for **3 seconds** (Figure 7C).
4. **Upper Power Value (UP):** After 3 seconds, the upper heat indicator will glow and the unit will display P XX (Figure 7D). Press the UP  or DOWN  arrow key until you reach the desired setting.

5. **Upper Time Value (UT):** Press the ENTER  button and the unit will display T XX (Figure 7E). Press the UP  or DOWN  arrow key until you reach the desired setting.
6. **Lower Power Value (LP):** Press the ENTER  button and the unit will display P XX (Figure 7F). Press the UP  or DOWN  arrow key until you reach the desired setting.
7. **Lower Time Value (LT):** Press the Enter  button and the unit will display T XX (Figure 7G). Press the UP  or DOWN  arrow key until you reach the desired setting.
8. Press the Program Selection button to enter all the settings into memory.

**NOTE:** If no adjustments are made within 15 seconds, the controller will revert back to the normal mode and will not accept any changes. Also, pressing any of the numbered Program buttons after this 15 second interval will take the unit out of the programming mode without accepting any changes.

9. If ready to finish food, place product in unit to the back wall and press desired Program Selection button.
10. Using a grease pencil or “China” pencil, record the specific food entree on the control panel next to the selected Program button.
11. Repeat steps 3 - 10 for the other Program buttons.

**NOTE:** All units keep the power and timing settings in memory, even when the unit is turned off or is unplugged from the power source.

**NOTE:** Models TF-2005, TF-2010 and TF-2045 do not have lower heating elements but all steps must be performed as if a bottom heating element is present. The power (LP) and time (LT) values set for the bottom zone must be less than the top zone for proper operation.

# PROGRAMMING CONTROLLER

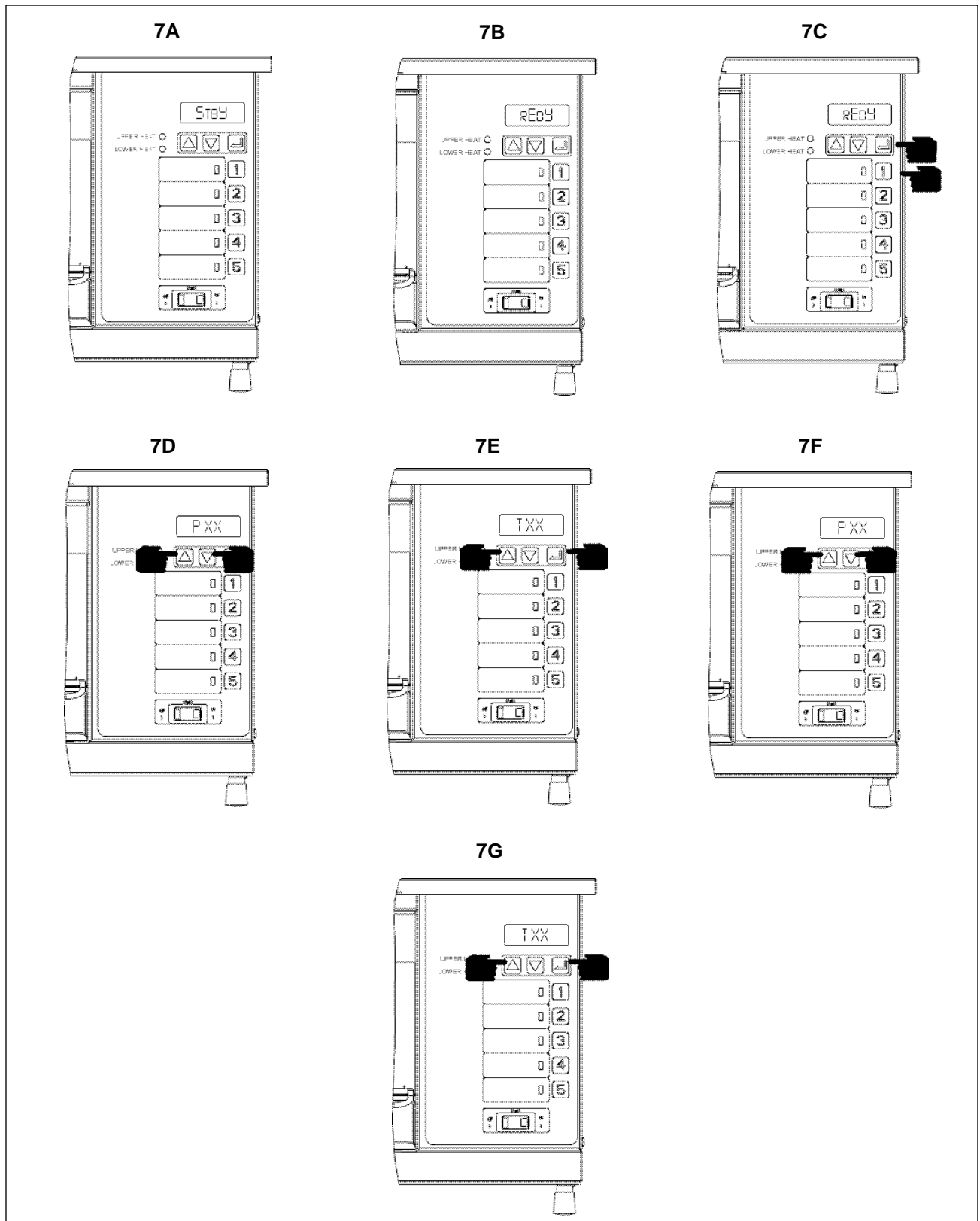

Figure 7. Programming a Selection

# PROGRAMMING CONTROLLER

---

## IDLE MODE

The Thermo-Finisher™ features an “Idle” mode. Once the unit reaches the **READY** mode, the upper heating element(s) automatically go into a programmed idle power setting. (The display will still show **READY** during the idle mode). The unit will stay in this mode until one of the five Program buttons is pressed, or the unit goes into auto-shut off.

**NOTE:** Begin by setting the idle mode power setting at 20% and adjust the program accordingly to achieve optimum performance.

To change the idle mode power setting, follow these steps:

1. Press and hold the UP  $\Delta$  arrow while, at the same time, press and hold the ENTER  $\leftarrow$  button for **three seconds**. The display will show the current programmed power value (Figure 8A).
2. To adjust the idle mode, press either the UP  $\Delta$  or DOWN  $\nabla$  arrow until you reach the desired setting (Figure 8B). Each time an arrow is pressed the setting will change by ten.
3. To accept the new value, push the ENTER  $\leftarrow$  button a second time (Figure 8C).

**NOTE:** If no adjustments are made within 15 seconds, the controller goes back to its original settings without accepting the change. Pushing any of the numbered program buttons will also take the controller out of programming mode without accepting the change.

## AUTO-OFF MODE

The Thermo-Finisher features an Auto-Off mode that turns all the elements off if the unit has not been used for a programmed length of time. This feature can be adjusted from 1 - 60 minutes in one minute increments, or it can be set to never shut off by itself.

To change the Auto-Off mode to a new setting, make sure unit is in **READY** mode and follow these steps:

1. Press and hold the DOWN  $\nabla$  arrow while at the same time press and hold the ENTER  $\leftarrow$  button for **three seconds**. The display will show the current programmed Auto-Off value (Figure 9A).

2. To adjust the Auto-Off time push either the UP  $\Delta$  or DOWN  $\nabla$  arrow until you reach the desired setting (Figure 9B). The Auto-Off mode can be adjusted from “0” (indicating unit will not turn off) to 60 minutes until turn off time, in single minute increments.
3. To accept the new Auto-Off time value, push the ENTER  $\leftarrow$  button a second time (Figure 9C).

**NOTE:** If no adjustments are made within 15 seconds the controller goes back to its original settings without accepting the change. Pressing any of the numbered buttons will also take the controller out of programming mode without accepting the change. To get the unit out of the Auto-Off Mode, push any one of the five numbered program buttons and the unit will begin operating.

## PROGRAMMING HINTS:

- On menu items in which internal temperatures are critical (such as chicken or pork), the primary heat source comes from the bottom. On menu items in which the surface temperatures are critical (such as cheese melting), the primary heat source comes from the top. See *Recommended Food Finishing Guide* for specific menu examples.
- When performing product testing, heat three plates with the same food product in succession. Adjust program accordingly to achieve optimum product temperature.
- When testing a menu item not listed in the *Recommended Food Finishing Guide* start by dividing the conventional cooking time by three and use that number as your cooking time. Set top and bottom heat at 50% and adjust accordingly if needed. Program setting will vary based on model and food product.

# PROGRAMMING CONTROLLER

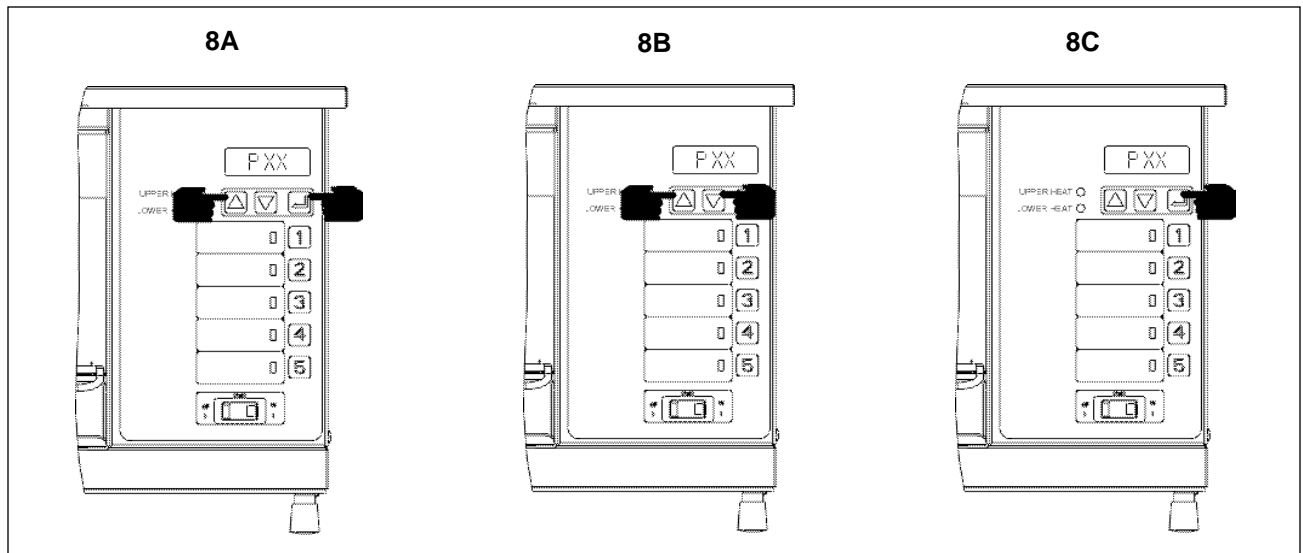

Figure 8. Programming Idle Mode

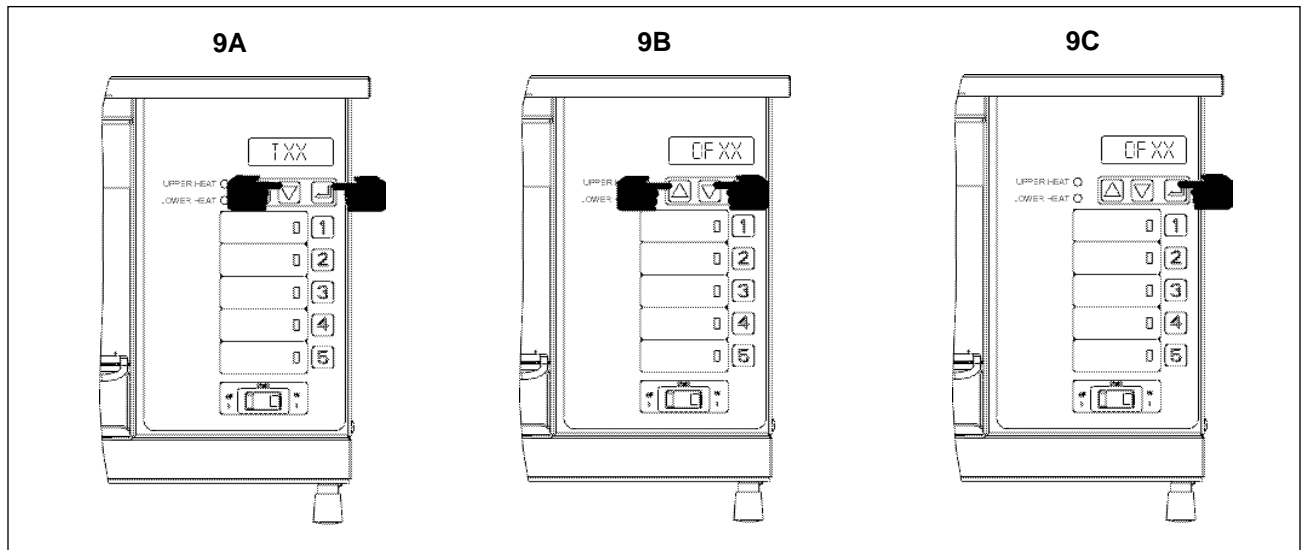

Figure 9. Programming Auto-Off Mode

# OPERATION

## BASIC FOOD FINISHING

### ⚠ CAUTION

Some exterior surfaces on the unit will get hot. Use caution when touching these areas to avoid injury.

### ⚠ CAUTION

To avoid any injury or damage to the unit do not operate appliance without installation of supplied legs.

### ⚠ CAUTION

DO NOT use “Pyrex” glass plates or serving pieces in the finisher. “Pyrex” glass may break causing personal injury and/or food contamination.

### ⚠ CAUTION

DO NOT use paper or plastic serving pieces in the finisher. These materials may melt or burn causing a fire hazard and/or food contamination and may damage the unit.

*NOTE:* See Recommended Food Finishing Guide for specific information.

1. Plug unit into a properly grounded electrical outlet of the correct voltage, size and plug configuration. See *Specifications* for details.
2. Turn the Power Switch to the ON position. (See Figure 10). The unit will make an audible beep, automatically go into Preheat mode and the display will indicate **PREH**. If the unit displays OFF, press one of the five product selection keys to put the unit into Preheat mode.

### CAUTION

Do not place any objects on the metal rack during preheat. Doing so will most likely over-cook the product.

3. When the Finisher has reached temperature and is ready for product, the unit will display **READY**. Place plate/tray with food product on far back of metal rack when unit is in **READY** mode.
4. Select one of five preprogrammed finishing cycles. Unit will beep and the display will begin counting down the programmed finishing time.

*NOTE:* If you make an incorrect selection it can be cancelled by selecting any of the buttons on the Control Panel.

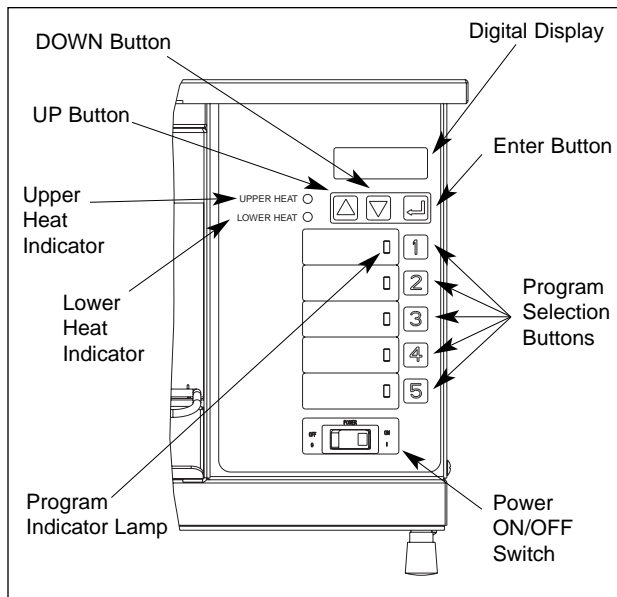

Figure 10. Control Panel

5. Finishing is complete when the display flashes **DONE**, the control panel lights flash and the unit beeps for five seconds. Remove product at this time.

### ⚠ CAUTION

Plate/tray will be very hot upon removal; use oven mitt, protective clothing, or pan gripper to remove.

*NOTE:* The beeping sound can be stopped before the five seconds have elapsed by selecting any of the buttons on the control panel.

6. Another plate/tray with food product can be placed on the rack when Finisher is in the **READY** mode. To heat, repeat steps 3, 4, and 5.

## FOOD FINISHING HINTS:

- Most menu items will require the Lower Power Value to be set higher than the Upper Power Value.
- Frozen or refrigerated food product can be heated in the unit. Frozen items do not have to be thawed first.
- Menu items that have completed a food finishing cycle but are not hot enough can be put back in the unit for additional heating.
- When testing a menu item not listed in the *Recommended Food Finishing Guide* start by dividing the conventional cooking time by three and use that number as your cooking time. Set top and bottom heat at 50% and adjust accordingly if needed. Program setting will vary based on model and food product.

*NOTE:* See Recommended Food Finishing Guide for specific information.

## GENERAL

The Hatco Thermo-Finisher™ warmers are designed for maximum durability and performance with minimum maintenance.

### WARNING

To avoid any injury, turn the power switch OFF, unplug the unit from the power source and allow to cool before performing any maintenance.

## CLEANING – EXTERIOR

To preserve the bright finish of the unit, it is recommended that the exterior surfaces be wiped daily with a damp cloth. Stubborn stains may be removed with a good stainless steel cleaner or a non-abrasive cleaner.

### CAUTION

Use only non-abrasive cleaners. Abrasive cleaners could scratch the finish of your Thermo-Finisher, marring its appearance and making it susceptible to dirt accumulation.

## BLOWER MOTORS

Inspect rear blower motors for food and/or grease build up and clean off if necessary.

## CLEANING – INTERIOR

### WIRE PLATE RACK

Remove rack from unit and wash with a mild soap and water solution and rinse.

### GLASS SURFACES

### WARNING

To avoid any injury, turn the power switch OFF, unplug the unit from the power source and allow to cool before performing any maintenance.

Upper and lower glass surfaces can be cleaned after the unit has *cooled for at least one hour*.

With the wire plate rack removed carefully use a “grill scraper” and scrape loose any food debris that has accumulated on the glass.

### CAUTION

Do not remove the glass from the unit for cleaning purposes. Doing so may cause injury or damage to the unit.

Remove any stains from the heating surfaces by wiping off the glass using a moist cloth and “ceramic cooking top cleaner.”

### WARNING

Unit is not waterproof. DO NOT submerge in water. Do not operate if it has been submerged in water. Do not steam clean the interior or flood with water or liquid solution.

### WARNING

To avoid electrical shock or personal injury, do not steam clean or use excessive water on the unit.

### WARNING

If service is required on this unit, contact your Authorized Hatco Service Agent, or contact the Hatco service Department at 800-558-0607 or 414-671-6350; fax 800-690-2966 or International fax 414-671-3976.

### WARNING

This product has no “user” serviceable parts. To avoid damage to the unit or injury to personnel, use only Authorized Hatco Service Agents and Genuine Hatco Replacement Parts when service is required.

### WARNING

Genuine Hatco Replacement Parts are specified to operate safely in the environments in which they are used. Some aftermarket or generic replacement parts do not have the characteristics that will allow them to operate safely in Hatco equipment. It is essential to use Hatco Replacement Parts when repairing Hatco equipment. Failure to use Hatco Replacement Parts may subject operators of the equipment to hazardous electrical voltage, resulting in electrical shock or burn.

## RECOMMENDED FOOD FINISHING GUIDE

(Time value is in minutes and seconds)				
Food Item	Upper Power Value (UP)	Upper Time Value (UT)	Lower Power Value (LP)	Lower Time Value (LT)
<b>Bratwurst</b> On tray, precooked for 20 minutes.	60	1 min. 40 sec.	100	2 min. 10 sec.
<b>Broccoli Mornay</b> Topped with a white sauce.	40	1 min.	100	2 min. 5 sec.
<b>Broiled Seasoned Tomato Halves</b>	80	8 min.	80	8 min.
<b>Cauliflower Mornay</b> Topped with a yellow cheese sauce.	40	1 min.	90	1 min. 40 sec.
<b>Chicken Fillet</b> Banquette honey-mustard breast patties.	70	3 min. 30 sec.	70	3 min. 30 sec.
<b>Chicken Kebabs</b> Spray tray with Pam product and spray product with Pam. Marinate overnight in soy sauce, ginger, salt and pepper. Skewer with raw onion, red and green pepper squares.	50	3 min. 40 sec.	80	3 min. 40 sec.
<b>Huevos Rancheros</b>	40	2 min.	100	1 min. 30 sec.
<b>Nachos</b>	50	50	50	50 sec.
<b>Noodles in White Herb Sauce</b> In casserole with Parmesan cheese.	10	4 min. 50 sec.	80	4 min. 50 sec.
<b>Onion Soup, French Style</b> In crock topped with two thin slices of French bread, grated Swiss cheese.	70	1 min. 20 sec.	50	1 min. 20 sec.
<b>Orange Roughy</b> Buttered.	70	2 min.	100	2 min. 5 sec.
<b>Pasta Shells in an Italian Cheese Sauce</b> In casserole topped with parmesan cheese (Add 2 Tbsp. of broth prior to heating).	10	4 min. 50 sec.	80	4 min. 50 sec.



## RECOMMENDED FOOD FINISHING GUIDE

(Time value is in minutes and seconds)				
Food Item	Upper Power Value (UP)	Upper Time Value (UT)	Lower Power Value (LP)	Lower Time Value (LT)
<b>Philly Sandwich</b> Toast Hoagie Roll separate from meat, onion and pepper filling.	20	1 min. 20 sec.	90	2 min. 10 sec.
<b>Sugar Cookies</b> Made on pizza pan.	10	2 min. 45 sec.	10	2 min. 45 sec.
<b>Pizza-Thin Crust</b>	40	4 min.	60	4 min.
<b>Pork Kebabs</b> Seasoned pork tenderloin squares on metal skewers, soy seasoned	60	5 min.	80	5 min.
<b>Potatoes Au Gratin</b> Boiled, diced, potatoes in a cheddar cheese sauce.	20	5 min.	80	5 min.
<b>Reuben Sandwich</b> On Rye with corned beef, Swiss cheese, sauerkraut, 1000 Island Dressing, buttered on both sides.	10	2 min. 15 sec.	90	2 min. 45 sec.
<b>Seasoned Oiled Onion Slices</b>	100	4 min. 20 sec.	100	4 min. 20 sec.
<b>Shrimp Poppers</b>	40	2 min. 55 sec.	40	2 min. 50 sec.

*NOTE: When testing a menu item not listed above start by dividing the conventional cooking time by three and use that number as your cooking time. Set top and bottom heat at 50% and adjust accordingly if needed. Program setting will vary based on model and food product.*

# HATCO LIMITED WARRANTY

---

## 1. PRODUCT WARRANTY

Hatco warrants the products that it manufactures (the "Products") to be free from defects in materials and workmanship, under normal use and service, for a period of one (1) year from the date of purchase when installed and maintained in accordance with Hatco's written instructions or 18 months from the date of shipment from Hatco. Buyer must establish the product's purchase date by returning Hatco's Warranty Registration Card or by other means satisfactory to Hatco in its sole discretion.

Hatco warrants the following Product components to be free from defects in materials and workmanship from the date of purchase (subject to the foregoing conditions) for the period(s) of time and on the conditions listed below:

- a) **One (1) Year Parts and Labor PLUS One (1) Additional Year Parts-Only Warranty:**
  - Toaster Elements (metal sheathed)
  - Drawer Warmer Elements (metal sheathed)
  - Drawer Warmer Drawer Rollers and Slides
  - Food Warmer Elements (metal sheathed)
  - Infra-Black® Elements (metal sheathed)
  - Display Warmer Elements (metal sheathed air heating)
  - Holding Cabinet Elements (metal sheathed air heating)
  
- b) **One (1) Year Parts and Labor PLUS Four (4) Additional Years Parts-Only Warranty on pro-rated terms that Hatco will explain at Buyer's Request:**
  - Powermite® Gas Booster Heater Tanks
  - Mini Compact Tanks (stainless steel)
  - 3CS and FR Tanks
  
- c) **One (1) Year Parts and Labor PLUS Four (4) Additional Years Parts-Only Warranty PLUS Five (5) Year Parts-Only Warranty on pro-rated terms that Hatco will explain at Buyer's Request:**
  - Booster Heater Tanks (Castone®)
  
- d) **One (1) Year Parts-Only Warranty for components not installed by Hatco:**
  - Accessory Components (including but not limited to valves, gauges and remote switches)

THE FOREGOING WARRANTIES ARE EXCLUSIVE AND IN LIEU OF ANY OTHER WARRANTY, EXPRESSED OR IMPLIED, INCLUDING BUT NOT LIMITED TO ANY IMPLIED WARRANTY OF MERCHANTABILITY OR FITNESS FOR A PARTICULAR PURPOSE OR PATENT OR OTHER INTELLECTUAL PROPERTY RIGHT INFRINGEMENT. Without limiting the generality of the foregoing, SUCH WARRANTIES DO NOT COVER: Coated incandescent light bulbs, fluorescent lights, lamp warmer heat bulbs, glass components, Product failure in booster tank, fin tube heat exchanger, or other water heating equipment, caused by liming, sediment buildup, chemical attack or freezing, Product misuse, tampering or misapplication, improper installation, application of improper voltage, or recalibration of thermostats or high limit switches, or transportation damage.

## 2. LIMITATION OF REMEDIES AND DAMAGES

Hatco's liability and Buyer's exclusive remedy hereunder will be limited solely, at Hatco's option, to repair or replacement by a Hatco-authorized service agency (other than where Buyer is located outside of the United States or Canada, in which case Hatco's liability and Buyer's exclusive remedy hereunder will be limited solely to replacement of part under warranty) with respect to any claim made within the applicable warranty period referred to above. Without limiting the generality of the foregoing, all portable Products (as defined in N.S.F. 4-4.28.4) shall be delivered by Buyer, at its sole expense, to the nearest Hatco-authorized service agency for replacement or repair. Hatco reserves the right to accept or reject any such claim in whole or in part. Hatco will not accept the return of any Product without prior written approval from Hatco, and all such approved returns shall be made at Buyer's sole expense. HATCO WILL NOT BE LIABLE, UNDER ANY CIRCUMSTANCES, FOR CONSEQUENTIAL OR INCIDENTAL DAMAGES, INCLUDING BUT NOT LIMITED TO LABOR COSTS OR LOST PROFITS RESULTING FROM THE USE OF OR INABILITY TO USE THE PRODUCTS OR FROM THE PRODUCTS BEING INCORPORATED IN OR BECOMING A COMPONENT OF ANY OTHER PRODUCT OR GOODS.



## HATCO AUTHORIZED PARTS DISTRIBUTORS

### ALABAMA

Jones McLeod Appl. Svc.  
Birmingham 205-251-0159

### ARIZONA

Auth. Comm. Food Equip.  
Phoenix 602-234-2443  
Byassee Equipment Co.  
Phoenix 602-252-0402

### CALIFORNIA

Industrial Electric  
Huntington Beach 714-379-7100  
Chapman Appl. Service  
San Diego 619-298-7106  
P & D Appliance  
S. San Francisco 650-635-1900

### COLORADO

Hawkins Commercial Appliance  
Englewood 303-781-5548

### DELAWARE

Food Equipment Service  
Wilmington 302-996-9363

### FLORIDA

Whaley Foodservice Repair  
Jacksonville 904-725-7800  
Nass Service Co., Inc.  
Orlando 407-425-2681  
B.G.S.I.  
Pompano Beach 954-971-0456  
Comm. Appliance Service  
Tampa 813-663-0313

### GEORGIA

Adcox Service Co.  
Atlanta 404-361-8010  
Southeastern Rest. Svc.  
Norcross 770-446-6177

### HAWAII

Burney's Comm. Service, Inc.  
Honolulu 808-848-1466  
Food Equip Parts & Service  
Honolulu 808-847-4871

### ILLINOIS

Parts Town  
Lombard 708-865-7278  
Eichenauer Elec. Service  
Decatur 217-429-4229  
Midwest Elec. Appl. Service  
Elmhurst 630-279-8000  
Cone's Repair Service  
Moline 309-797-5323

### INDIANA

GCS Service  
Indianapolis 317-545-9655

### IOWA

Electric Motor Service Co.  
Davenport 319-323-1823

### KENTUCKY

GCS Service  
Louisville 502-367-1788

### LOUISIANA

Chandlers Parts & Service  
Baton Rouge 225-272-6620  
Bana Comm. Parts, Inc.  
Shreveport 318-631-6550

### MARYLAND

Electric Motor Service  
Baltimore 410-467-8080  
GCS Service  
Silver Spring 301-585-7550

### MASSACHUSETTS

Ace Service Co., Inc.  
Needham 781-449-4220

### MICHIGAN

Commercial Kitchen Service  
Bay City 517-893-4561  
Bildons Appliance Service  
Detroit 248-478-3320

Midwest Food Equip. Service  
Grandville 616-261-2000

### MINNESOTA

GCS Service  
Minneapolis 612-546-4221

### MISSOURI

GCS Service  
Kansas City 816-920-5999  
Commercial Kitchen Services  
St. Louis 314-890-0700  
Kaemmerlen Parts & Service  
St. Louis 314-535-2222

### NEBRASKA

Anderson Electric  
Omaha 402-341-1414

### NEVADA

Burney's Commercial  
Las Vegas 702-736-0006  
Hi. Tech Commercial Service  
N. Las Vegas 702-649-4616

### NEW JERSEY

Jay Hill Repair  
Fairfield 973-575-9145  
Service Plus  
Flanders 973-691-6300

### NEW YORK

Acme American Repairs, Inc.  
Brooklyn 718-456-6544

### NEW YORK (continued)

Alpro Service Co.  
Brooklyn 718-386-2515  
Appliance Installation  
Buffalo 716-884-7425  
Northern Parts Dist.  
Plattsburgh 518-563-3200

J.B. Brady, Inc.  
Syracuse 315-422-9271

### NORTH CAROLINA

Authorized Appliance  
Charlotte 704-377-4501

### OHIO

Akron/Canton Comm. Svc. Inc.  
Akron 330-753-6635  
Certified Service Center  
Cincinnati 513-772-6600

GCS Service  
Columbus 614-476-3225  
Electrical Appl. Repair Service  
Independence 216-459-8700

E. A. Wichman Co.  
Toledo 419-385-9121

### OKLAHOMA

Hagar Rest. Service, Inc.  
Oklahoma City 405-235-2184  
Krueger, Inc.  
Oklahoma City 405-528-8883

### OREGON

Bressie Electric Co.  
Portland 503-231-7171  
Ron's Service, Inc.  
Portland 503-624-0890

### PENNSYLVANIA

FAST Comm. Appl. Service  
Philadelphia 215-288-4800  
GCS Service  
Pittsburgh 412-787-1970

K & D Service Co.  
Harrisburg 717-236-9039  
Elmer Schultz Services  
Philadelphia 215-627-5401

Electric Repair Co.  
Reading 610-376-5444

### RHODE ISLAND

Marshall Electric Co.  
Providence 401-331-1163

### SOUTH CAROLINA

Whaley Foodservice Repair  
W. Columbia 803-791-4420

### TENNESSEE

Camp Electric  
Memphis 901-527-7543

### TEXAS

Stove Parts Supply  
Fort Worth 817-831-0381

Armstrong Repair Service  
Houston 713-666-7100  
Commercial Kitchen Repair Co.  
San Antonio 210-735-2811

San Antonio Rest. Equip.  
San Antonio 210-532-1660

### UTAH

GCS Service  
Salt Lake City 801-487-3653

### VIRGINIA

Daubers  
Norfolk 757-855-4097  
Daubers  
Springfield 703-866-3600

### WASHINGTON

Restaurant Appl. Service  
Seattle 206-524-8200

### WISCONSIN

A.S.C., Inc.  
Madison 608-246-3160  
A.S.C., Inc.  
Milwaukee 414-543-6460

## CANADA

### BRITISH COLUMBIA

Key Food Equipment Service  
Vancouver 604-433-4484

### ONTARIO

R.G. Henderson Ltd.  
Toronto 416-422-5580  
Choquette CKS  
Ottawa 613-739-8458

### QUÉBEC

Choquette CKS  
Montreal 514-722-2000  
Choquette CKS  
Québec City 418-681-3944

## HATCO CORPORATION

P.O. Box 340500, Milwaukee, WI 53234-0500 U.S.A.

(800) 558-0607 (414) 671-6350

Parts & Service Fax (800) 690-2966 Int'l. Fax (414) 671-3976

www.hatcocorp.com